



A D T

# FCC TEST REPORT

**REPORT NO.:** RF990728D17-1

**MODEL NO.:** MA3GMRX,  
WX-DL-Dongle

**FCC ID:** O62MA3GMRX

**RECEIVED:** July 28, 2010

**TESTED:** Aug. 11 ~ 18, 2010

**ISSUED:** Aug. 23, 2010

**APPLICANT:** Darfon Electronics Corp

**ADDRESS:** 167, Shanying Road, Gueishan, Taoyuan 333,  
Taiwan

**ISSUED BY:** Bureau Veritas Consumer Products Services  
(H.K.) Ltd., Taoyuan Branch

**LAB LOCATION:** No. 47, 14th Ling, Chia Pau Tsuen, Lin Kou  
Hsiang, Taipei Hsien, 244 Taiwan

This test report consists of 42 pages in total. It may be duplicated completely for legal use with the approval of the applicant. It should not be reproduced except in full, without the written approval of our laboratory. The client should not use it to claim product endorsement by TAF or any government agencies. The test results in the report only apply to the tested sample.





A D T

## TABLE OF CONTENTS

1.	CERTIFICATION.....	4
2.	SUMMARY OF TEST RESULTS .....	5
2.1	MEASUREMENT UNCERTAINTY .....	5
3.	GENERAL INFORMATION .....	6
3.1	GENERAL DESCRIPTION OF EUT .....	6
3.2	DESCRIPTION OF TEST MODES .....	7
3.2.1	CONFIGURATION OF SYSTEM UNDER TEST.....	7
3.2.2	TEST MODE APPLICABILITY AND TESTED CHANNEL DETAIL.....	8
3.3	GENERAL DESCRIPTION OF APPLIED STANDARDS.....	10
3.4	DESCRIPTION OF SUPPORT UNITS.....	10
4.	TEST TYPES AND RESULTS.....	11
4.1	CONDUCTED EMISSION MEASUREMENT.....	11
4.1.1	LIMITS OF CONDUCTED EMISSION MEASUREMENT .....	11
4.1.2	TEST INSTRUMENTS.....	11
4.1.3	TEST PROCEDURES .....	12
4.1.4	DEVIATION FROM TEST STANDARD.....	12
4.1.5	TEST SETUP .....	12
4.1.6	EUT OPERATING CONDITIONS.....	13
4.1.7	TEST RESULTS .....	14
4.2	RADIATED EMISSION MEASUREMENT .....	16
4.2.1	LIMITS OF RADIATED EMISSION MEASUREMENT .....	16
4.2.2	TEST INSTRUMENTS.....	17
4.2.3	TEST PROCEDURES .....	18
4.2.4	DEVIATION FROM TEST STANDARD.....	18
4.2.5	TEST SETUP .....	19
4.2.6	EUT OPERATING CONDITIONS.....	19
4.2.7	TEST RESULTS .....	20
4.3	6DB BANDWIDTH MEASUREMENT .....	26
4.3.1	LIMITS OF 6DB BANDWIDTH MEASUREMENT .....	26
4.3.2	TEST INSTRUMENTS.....	26
4.3.3	TEST PROCEDURE .....	26
4.3.4	DEVIATION FROM TEST STANDARD.....	26
4.3.5	TEST SETUP .....	27
4.3.6	EUT OPERATING CONDITIONS.....	27
4.3.7	TEST RESULTS .....	28
4.4	MAXIMUM OUTPUT POWER .....	29
4.4.1	LIMITS OF MAXIMUM PEAK OUTPUT POWER MEASUREMENT.....	29



A D T

4.4.2	INSTRUMENTS .....	29
4.4.3	TEST PROCEDURES .....	29
4.4.4	DEVIATION FROM TEST STANDARD .....	30
4.4.5	TEST SETUP .....	30
4.4.6	EUT OPERATING CONDITIONS.....	30
4.4.7	TEST RESULTS .....	31
4.5	POWER SPECTRAL DENSITY MEASUREMENT .....	32
4.5.1	LIMITS OF POWER SPECTRAL DENSITY MEASUREMENT .....	32
4.5.2	TEST INSTRUMENTS .....	32
4.5.3	TEST PROCEDURE .....	32
4.5.4	DEVIATION FROM TEST STANDARD .....	33
4.5.5	TEST SETUP .....	33
4.5.6	EUT OPERATING CONDITION .....	33
4.5.7	TEST RESULTS .....	34
4.6	BAND EDGES MEASUREMENT .....	35
4.6.1	LIMITS OF BAND EDGES MEASUREMENT .....	35
4.6.2	TEST INSTRUMENTS .....	35
4.6.3	TEST PROCEDURE .....	35
4.6.4	DEVIATION FROM TEST STANDARD .....	35
4.6.5	EUT OPERATING CONDITION .....	35
4.6.6	TEST RESULTS .....	36
5.	PHOTOGRAPHS OF THE TEST CONFIGURATION .....	40
6.	INFORMATION ON THE TESTING LABORATORIES.....	41
7.	APPENDIX A - MODIFICATIONS RECORDERS FOR ENGINEERING CHANGES TO THE EUT BY THE LAB .....	42



A D T

## 1. CERTIFICATION

**PRODUCT:** Dongle  
**BRAND NAME:** ASUS  
**MODEL NO.:** MA3GMRX, WX-DL-Dongle  
**APPLICANT:** Darfon Electronics Corp  
**TEST SAMPLE:** R & D SAMPLE  
**TESTED:** Aug. 11 ~ 18, 2010  
**STANDARDS:** **FCC Part 15, Subpart C (Section 15.247)**  
**ANSI C63.4-2003**

The above equipment (Mode: WX-DL-Dongle) has been tested by **Bureau Veritas Consumer Products Services (H.K.) Ltd., Taoyuan Branch**, and found compliance with the requirement of the above standards. The test record, data evaluation & Equipment Under Test (EUT) configurations represented herein are true and accurate accounts of the measurements of the sample's EMC characteristics under the conditions specified in this report.

**PREPARED BY :**           Jessica Cheng           , **DATE:**           Aug. 23, 2010            
( Jessica Cheng / Specialist )

**TECHNICAL ACCEPTANCE :**           Jamison Chan           , **DATE:**           Aug. 23, 2010            
Responsible for RF ( Jamison Chan / Supervisor )

**APPROVED BY :**           Ken Liu           , **DATE:**           Aug. 23, 2010            
( Ken Liu / Manager )



## 2. SUMMARY OF TEST RESULTS

The EUT has been tested according to the following specifications:

APPLIED STANDARD: FCC PART 15, SUBPART C (SECTION 15.247)			
STANDARD SECTION	TEST TYPE AND LIMIT	RESULT	REMARK
15.207	AC Power Conducted Emission	PASS	Meet the requirement of limit. Minimum passing margin is -8.69 dB at 20.078MHz
15.247(a)(2)	Spectrum Bandwidth of a Direct Sequence Spread Spectrum System Limit: min. 500kHz	PASS	Meet the requirement of limit.
15.247(b)	Maximum Peak Output Power Limit: max. 30dBm	PASS	Meet the requirement of limit.
15.247(d)	Radiated Emissions Limit: Table 15.209	PASS	Meet the requirement of limit. Minimum passing margin is -4.4 dB at 7320.00MHz
15.247(e)	Power Spectral Density Limit: max. 8dBm	PASS	Meet the requirement of limit.
15.247(d)	Band Edge Measurement Limit: 20dB less than the peak value of fundamental frequency	PASS	Meet the requirement of limit.
15.203	Antenna Requirement	PASS	No antenna connector is used.

### 2.1 MEASUREMENT UNCERTAINTY

Where relevant, the following measurement uncertainty levels have been estimated for tests performed on the EUT as specified in CISPR 16-4-2:

This uncertainty represents an expanded uncertainty expressed at approximately the 95% confidence level using a coverage factor of  $k = 2$ .

MEASUREMENT	FREQUENCY	UNCERTAINTY
Conducted emissions	150kHz~30MHz	2.41 dB
Radiated emissions	30MHz~1GHz	3.67 dB
	Above 1GHz	2.89 dB



### 3. GENERAL INFORMATION

#### 3.1 GENERAL DESCRIPTION OF EUT

<b>PRODUCT</b>	Dongle
<b>MODEL NO.</b>	MA3GMRX, WX-DL-Dongle
<b>FCC ID</b>	O62MA3GMRX
<b>POWER SUPPLY</b>	5Vdc from host equipment
<b>MODULATION TYPE</b>	GFSK
<b>OPERATING FREQUENCY</b>	2403MHz ~ 2479MHz
<b>NUMBER OF CHANNEL</b>	77
<b>OUTPUT POWER</b>	1.3mW
<b>ANTENNA TYPE</b>	PCB antenna with 1.44dBi gain
<b>ANTENNA CONNECTOR</b>	NA
<b>DATA CABLE</b>	NA
<b>I/O PORTS</b>	USB port
<b>ASSOCIATED DEVICES</b>	NA

**NOTE:**

1. The EUT has several models, which are identical to each other except for the following:

<b>Product Name</b>	<b>Model No.</b>	<b>Differentiation</b>
DONGLE	MA3GMRX	Marketing differentiation
	WX-DL-Dongle	

During the test, model: **WX-DL-Dongle** was selected as the representative one and therefore only its test data was recorded in this report.

2. The EUT is a transceiver.
3. The above EUT information was declared by the manufacturer and for more detailed features description, please refer to the manufacturer's specifications or User's Manual.

### 3.2 DESCRIPTION OF TEST MODES

77 channels are provided to this EUT:

CHANNEL	FREQ. (MHZ)	CHANNEL	FREQ. (MHZ)	CHANNEL	FREQ. (MHZ)	CHANNEL	FREQ. (MHZ)
1	2403	21	2423	41	2443	61	2463
2	2404	22	2424	42	2444	62	2464
3	2405	23	2425	43	2445	63	2465
4	2406	24	2426	44	2446	64	2466
5	2407	25	2427	45	2447	65	2467
6	2408	26	2428	46	2448	66	2468
7	2409	27	2429	47	2449	67	2469
8	2410	28	2430	48	2450	68	2470
9	2411	29	2431	49	2451	69	2471
10	2412	30	2432	50	2452	70	2472
11	2413	31	2433	51	2453	71	2473
12	2414	32	2434	52	2454	72	2474
13	2415	33	2435	53	2455	73	2475
14	2416	34	2436	54	2456	74	2476
15	2417	35	2437	55	2457	75	2477
16	2418	36	2438	56	2458	76	2478
17	2419	37	2439	57	2459	77	2479
18	2420	38	2440	58	2460		
19	2421	39	2441	59	2461		
20	2422	40	2442	60	2462		

#### 3.2.1 CONFIGURATION OF SYSTEM UNDER TEST

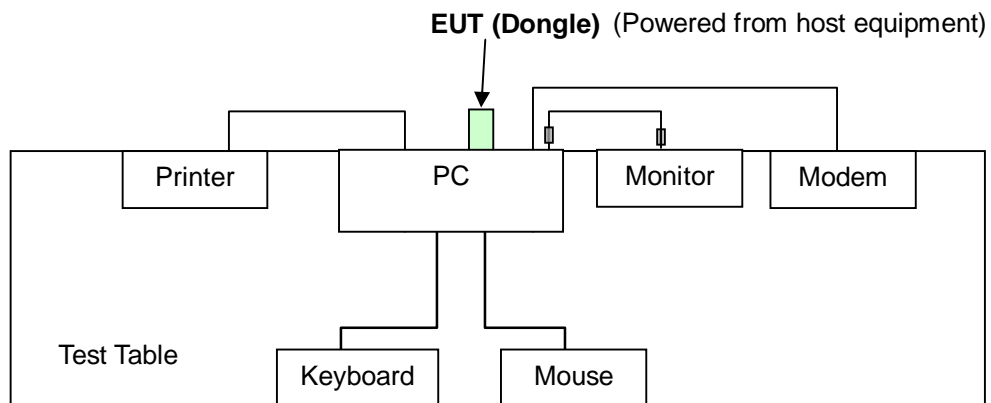



### 3.2.2 TEST MODE APPLICABILITY AND TESTED CHANNEL DETAIL

EUT CONFIGURE MODE	APPLICABLE TO				DESCRIPTION
	PLC	RE <sup>3</sup> 1G	RE<1G	APCM	
-	√	√	√	√	-

Where **RE<sup>3</sup>1G**: Radiated Emission above 1GHz      **RE<1G**: Radiated Emission below 1GHz  
**PLC**: Power Line Conducted Emission      **APCM**: Antenna Port Conducted Measurement

#### **POWER LINE CONDUCTED EMISSION TEST:**

- Pre-Scan has been conducted to determine the worst-case mode from all possible combinations between available modulations, data rates and antenna ports (if EUT with antenna diversity architecture).
- Following channel(s) was (were) selected for the final test as listed below.

AVAILABLE CHANNEL	TESTED CHANNEL	MODULATION TYPE
1 to 77	1	GFSK

#### **RADIATED EMISSION TEST (ABOVE 1GHz):**

- Pre-Scan has been conducted to determine the worst-case mode from all possible combinations between available modulations, data rates and antenna ports (if EUT with antenna diversity architecture).
- Following channel(s) was (were) selected for the final test as listed below.

AVAILABLE CHANNEL	TESTED CHANNEL	MODULATION TYPE
1 to 77	1, 38, 77	GFSK

#### **RADIATED EMISSION TEST (BELOW 1GHz):**

- Pre-Scan has been conducted to determine the worst-case mode from all possible combinations between available modulations, data rates and antenna ports (if EUT with antenna diversity architecture).
- Following channel(s) was (were) selected for the final test as listed below.

AVAILABLE CHANNEL	TESTED CHANNEL	MODULATION TYPE
1 to 77	1	GFSK





**BANDEDGE MEASUREMENT:**

- Pre-Scan has been conducted to determine the worst-case mode from all possible combinations between available modulations, data rates and antenna ports (if EUT with antenna diversity architecture).
- Following channel(s) was (were) selected for the final test as listed below.

AVAILABLE CHANNEL	TESTED CHANNEL	MODULATION TYPE
1 to 77	1, 77	GFSK

**ANTENNA PORT CONDUCTED MEASUREMENT:**

- This item includes all test value of each mode, but only includes spectrum plot of worst value of each mode.
- Pre-Scan has been conducted to determine the worst-case mode from all possible combinations between available modulations, data rates and antenna ports (if EUT with antenna diversity architecture).
- Following channel(s) was (were) selected for the final test as listed below.

AVAILABLE CHANNEL	TESTED CHANNEL	MODULATION TYPE
1 to 77	1, 38, 77	GFSK

**TEST CONDITION:**

APPLICABLE TO	ENVIRONMENTAL CONDITIONS	INPUT POWER (SYSTEM)	TESTED BY
PLC	26deg. C, 65% RH, 1012hPa	120Vac, 60Hz	Jun Wu
RE <sup>3</sup> 1G	26deg. C, 59% RH, 1009hPa	120Vac, 60Hz	Nick Chen
RE <1G	26deg. C, 59% RH, 1009hPa	120Vac, 60Hz	Nick Chen
APCM	28deg. C, 83% RH, 1010hPa	120Vac, 60Hz	Jamison Chan



A D T

### 3.3 GENERAL DESCRIPTION OF APPLIED STANDARDS

The EUT is a RF Product. According to the specifications of the manufacturer, it must comply with the requirements of the following standards:

#### FCC Part 15, Subpart C (15.247)

#### ANSI C63.4-2003

All test items have been performed and recorded as per the above standards.

**NOTE:** The product has been verified to comply with the requirements of FCC Part 15, Subpart B, Class B (DoC). The test report has been issued separately.

### 3.4 DESCRIPTION OF SUPPORT UNITS

The EUT has been tested as an independent unit together with other necessary accessories or support units. The following support units or accessories were used to form a representative test configuration during the tests.

NO.	PRODUCT	BRAND	MODEL NO.	SERIAL NO.	FCC ID
1	PERSONAL COMPUTER	HP	dx7300MT	SGH72102NP	FCC DoC Approved
2	LCD MONITOR	BenQ	Q24W5	ET18712601SL 0	FCC DoC Approved
3	PRINTER	EPSON	LQ-300+	DCGY017054	FCC DoC Approved
4	MODEM	ACEEX	1414	980020520	IFAXDM1414
5	PS/2 KEYBOARD	HP	KB-0316	BC3520BGAUJ 008	FCC DoC Approved
6	PS/2 MOUSE	BTC	M851	N/A	E5XMSM860

NO.	SIGNAL CABLE DESCRIPTION OF THE ABOVE SUPPORT UNITS
1	N/A
2	1.8m D-Sub cable with two cores.
3	1.8m braid shielded wire, terminated with DB25 and Centronics connector via metallic frame, w/o core
4	1.2 m braid shielded wire, terminated with DB25 and DB9 connector via metallic frame, w/o core.
5	1.8 m foil shielded wire, terminated with PS/2 connector via metallic frame, w/o core.
6	1.5 m Non shielded wire, terminated with PS/2 connector via drain wire, w/o core.

**NOTE:** All power cords of the above support units are non shielded (1.8m).



A D T

## 4. TEST TYPES AND RESULTS

### 4.1 CONDUCTED EMISSION MEASUREMENT

#### 4.1.1 LIMITS OF CONDUCTED EMISSION MEASUREMENT

FREQUENCY OF EMISSION (MHz)	CONDUCTED LIMIT (dB $\mu$ V)	
	Quasi-peak	Average
0.15-0.5	66 to 56	56 to 46
0.5-5	56	46
5-30	60	50

**NOTE:**

1. The lower limit shall apply at the transition frequencies.
2. All emanations from a class A/B digital device or system, including any network of conductors and apparatus connected thereto, shall not exceed the level of field strengths specified above.

#### 4.1.2 TEST INSTRUMENTS

DESCRIPTION & MANUFACTURER	MODEL NO.	SERIAL NO.	CALIBRATED DATE	CALIBRATED UNTIL
ROHDE & SCHWARZ Test Receiver	ESCS 30	100276	Dec. 15, 2009	Dec. 14, 2010
ROHDE & SCHWARZ Artificial Mains Network (for EUT)	ESH3-Z5	100218	Nov. 24, 2009	Nov. 23, 2010
LISN With Adapter (for EUT)	AD10	C10Ada-001	Nov. 24, 2009	Nov. 23, 2010
ROHDE & SCHWARZ Artificial Mains Network (for peripherals)	ESH3-Z5	100219	Nov. 23, 2009	Nov. 22, 2010
Software	ADT_Cond_V7.3.7	NA	NA	NA
Software	ADT_ISN_V7.3.7	NA	NA	NA
RF cable (JYEBAO)	5D-FB	Cable-C10.01	Feb. 23, 2010	Feb. 22, 2011
SUHNER Terminator (For ROHDE & SCHWARZ LISN)	65BNC-5001	E1-010773	Feb. 23, 2010	Feb. 22, 2011

- NOTE:**
1. The calibration interval of the above test instruments is 12 months and the calibrations are traceable to NML/ROC and NIST/USA.
  2. The test was performed in Shielded Room No. 10.

3. The VCCI Site Registration No. C-1852.

### 4.1.3 TEST PROCEDURES

- a. The EUT was placed 0.4 meters from the conducting wall of the shielded room with EUT being connected to the power mains through a line impedance stabilization network (LISN). Other support units were connected to the power mains through another LISN. The two LISNs provide 50 ohm/ 50uH of coupling impedance for the measuring instrument.
- b. Both lines of the power mains connected to the EUT were checked for maximum conducted interference.
- c. The frequency range from 150kHz to 30MHz was searched. Emission levels under limit - 20dB was not recorded.

### 4.1.4 DEVIATION FROM TEST STANDARD

No deviation.

### 4.1.5 TEST SETUP

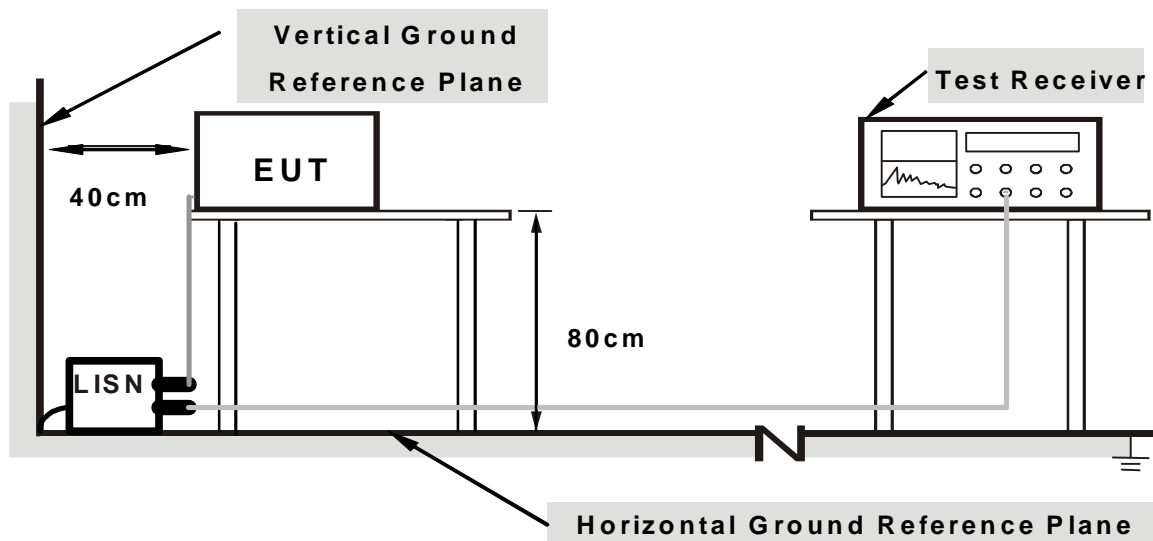

- Note:**
1. Support units were connected to second LISN.
  2. Both of LISNs (AMN) are 80 cm from EUT and at least 80 cm from other units and other metal planes

For the actual test configuration, please refer to the related item – Photographs of the Test Configuration.



A D T

#### 4.1.6 EUT OPERATING CONDITIONS

- a. Connected the EUT to a PC placed on a testing table.
- b. PC ran a test program (provided by manufacturer) to enable EUT under transmission/receiving condition continuously at specific channel frequency.
- c. PC read and wrote messages to/ from HDD.
- d. PC sent messages to monitor and displayed on its screen.
- e. PC sent messages to printer, and the printer printed them out.
- f. PC sent messages to modem.
- g. Repeated c ~ g.

### 4.1.7 TEST RESULTS

#### CONDUCTED WORST CASE DATA

<b>PHASE</b>	Line 1	<b>6dB BANDWIDTH</b>	9 kHz
--------------	--------	----------------------	-------

No	Freq. [MHz]	Corr. Factor (dB)	Reading Value		Emission Level		Limit		Margin	
			[dB (uV)]		[dB (uV)]		[dB (uV)]		(dB)	
			Q.P.	AV.	Q.P.	AV.	Q.P.	AV.	Q.P.	AV.
1	0.177	0.19	50.11	-	50.30	-	64.61	54.61	-14.31	-
2	0.240	0.21	41.06	-	41.27	-	62.10	52.10	-20.83	-
3	4.105	0.49	32.89	-	33.38	-	56.00	46.00	-22.62	-
4	4.590	0.51	34.14	-	34.65	-	56.00	46.00	-21.35	-
<b>5</b>	<b>20.078</b>	<b>1.26</b>	<b>49.47</b>	<b>40.05</b>	<b>50.73</b>	<b>41.31</b>	<b>60.00</b>	<b>50.00</b>	<b>-9.27</b>	<b>-8.69</b>
6	21.035	1.28	47.81	-	49.09	-	60.00	50.00	-10.91	-

- REMARKS:**
1. Q.P. and AV. are abbreviations of quasi-peak and average individually.
  2. "-": The Quasi-peak reading value also meets average limit and measurement with the average detector is unnecessary.
  3. The emission levels of other frequencies were very low against the limit.
  4. Margin value = Emission level - Limit value
  5. Correction factor = Insertion loss + Cable loss
  6. Emission Level = Correction Factor + Reading Value.

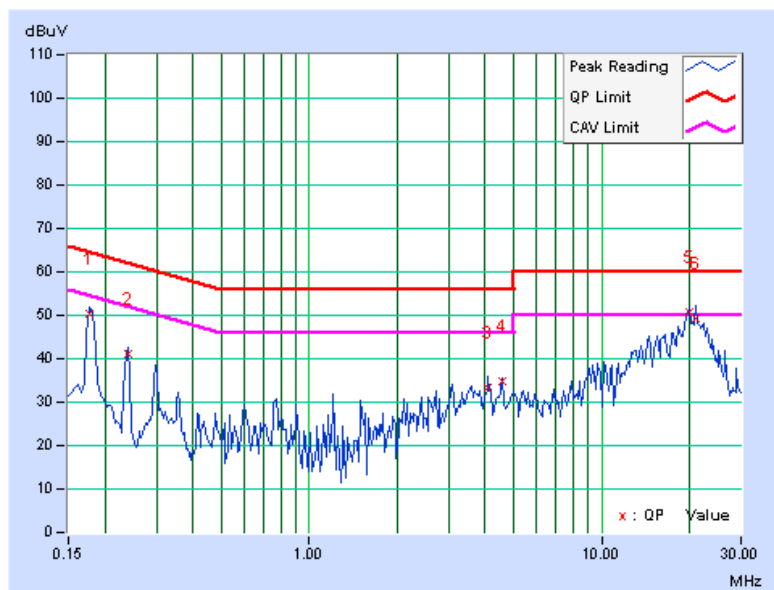



A D T

PHASE	Line 2	6dB BANDWIDTH	9 kHz
-------	--------	---------------	-------

No	Freq. [MHz]	Corr. Factor (dB)	Reading Value		Emission Level		Limit		Margin	
			[dB (uV)]		[dB (uV)]		[dB (uV)]		(dB)	
			Q.P.	AV.	Q.P.	AV.	Q.P.	AV.	Q.P.	AV.
1	0.177	0.28	49.25	-	49.53	-	64.61	54.61	-15.07	-
2	0.240	0.30	40.94	-	41.24	-	62.10	52.10	-20.86	-
3	0.654	0.38	23.69	-	24.07	-	56.00	46.00	-31.93	-
4	3.719	0.53	31.65	-	32.18	-	56.00	46.00	-23.82	-
5	15.547	0.94	41.27	-	42.21	-	60.00	50.00	-17.79	-
6	20.672	1.05	46.13	-	47.18	-	60.00	50.00	-12.82	-

- REMARKS:**
1. Q.P. and AV. are abbreviations of quasi-peak and average individually.
  2. "-": The Quasi-peak reading value also meets average limit and measurement with the average detector is unnecessary.
  3. The emission levels of other frequencies were very low against the limit.
  4. Margin value = Emission level - Limit value
  5. Correction factor = Insertion loss + Cable loss
  6. Emission Level = Correction Factor + Reading Value.

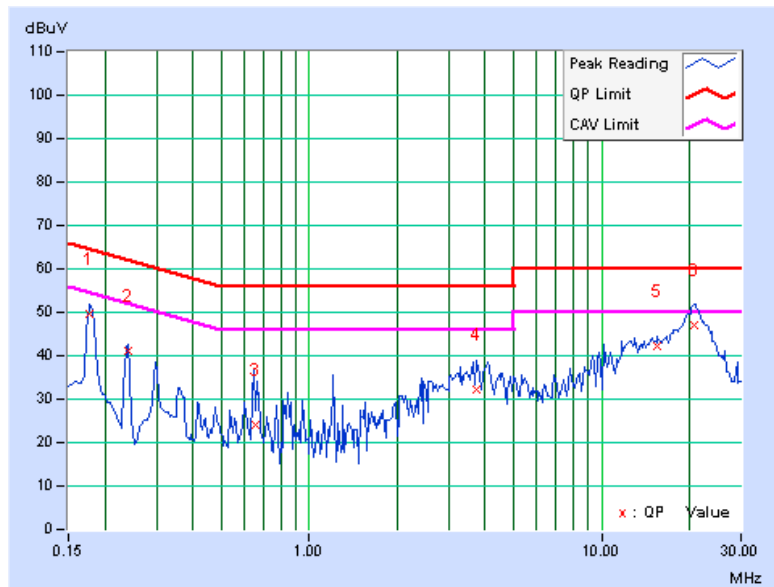



## 4.2 RADIATED EMISSION MEASUREMENT

### 4.2.1 LIMITS OF RADIATED EMISSION MEASUREMENT

Emissions radiated outside of the specified bands, shall be according to the general radiated limits in 15.209 as following:

FREQUENCIES (MHz)	FIELD STRENGTH (microvolts/meter)	MEASUREMENT DISTANCE (meters)
0.009 ~ 0.490	2400/F(kHz)	300
0.490 ~ 1.705	24000/F(kHz)	30
1.705 ~ 30.0	30	30
30 ~ 88	100	3
88 ~ 216	150	3
216 ~ 960	200	3
Above 960	500	3

**NOTE:**

1. The lower limit shall apply at the transition frequencies.
2. Emission level (dBuV/m) = 20 log Emission level (uV/m).
3. As shown in 15.35(b), for frequencies above 1000MHz, the field strength limits are based on average detector, however, the peak field strength of any emission shall not exceed the maximum permitted average limits, specified above by more than 20dB under any condition of modulation.





A D T

## 4.2.2 TEST INSTRUMENTS

DESCRIPTION & MANUFACTURER	MODEL NO.	SERIAL NO.	CALIBRATED DATE	CALIBRATED UNTIL
HP Preamplifier	8447D	2432A03504	May 06, 2010	May 05, 2011
HP Preamplifier	8449B	3008A01924	Jul. 14, 2010	Jul. 13, 2011
HP Preamplifier	8449B	3008A01292	Jul. 14, 2010	Jul. 13, 2011
ROHDE & SCHWARZ TEST RECEIVER	ESU26	100005	Jun. 10, 2010	Jun. 09, 2011
Schwarzbeck Antenna	VULB 9168	137	Apr. 29, 2010	Apr. 28, 2011
Schwarzbeck Antenna	VHBA 9123	480	Apr. 29, 2010	Apr. 28, 2011
ADT. Turn Table	TT100	0306	NA	NA
ADT. Tower	AT100	0306	NA	NA
Software	ADT_Radiated_V 7.6.15.9.2	NA	NA	NA
SUHNER RF cable	SF104-26.5	CABLE-CH6-17m -01	Aug. 20, 2009	Aug. 19, 2010
ROHDE & SCHWARZ Spectrum Analyzer	FSP 40	100036	Apr. 06, 2010	Apr. 05, 2011
EMCO Horn Antenna	3115	6714	Oct. 26, 2009	Oct. 25, 2010
EMCO Horn Antenna	3115	9312-4192	Apr. 23, 2010	Apr. 22, 2011

- NOTE:** 1. The calibration interval of the above test instruments is 12/24 months. And the calibrations are traceable to NML/ROC and NIST/USA.  
2. The horn antenna and HP preamplifier (model: 8449B) are used only for the measurement of emission frequency above 1GHz if tested.  
3. The test was performed in Chamber No. 6.  
4. The Industry Canada Reference No. IC 7450E-6.  
5. The FCC Site Registration No. is 447212.



### 4.2.3 TEST PROCEDURES

- a. The EUT was placed on the top of a rotating table 0.8 meters above the ground at a 3 meters semi-anechoic chamber. The table was rotated 360 degrees to determine the position of the highest radiation.
- b. The EUT was set 3 meters away from the interference-receiving antenna, which was mounted on the top of a variable-height antenna tower.
- c. The height of antenna is varied from one meter to four meters above the ground to determine the maximum value of the field strength. Both horizontal and vertical polarizations of the antenna are set to make the measurement.
- d. For each suspected emission, the EUT was arranged to its worst case and then the antenna was tuned to heights from 1 meter to 4 meters and the rotatable table was turned from 0 degrees to 360 degrees to find the maximum reading.
- e. The test-receiver system was set to Peak Detect Function and Specified Bandwidth with Maximum Hold Mode.
- f. If the emission level of the EUT in peak mode was lower than the limit specified, then testing could be stopped and the peak values of the EUT would be reported. Otherwise the emissions would be re-tested one by one using peak, quasi-peak or average method as specified and then reported in a data sheet.

**NOTE:**

1. The resolution bandwidth and video bandwidth of test receiver/spectrum analyzer is 120kHz for Peak detection (PK) and Quasi-peak detection (QP) at frequency below 1GHz.
2. The resolution bandwidth of test receiver/spectrum analyzer is 1MHz and video bandwidth is 3MHz for Peak detection at frequency above 1GHz.
3. The resolution bandwidth of test receiver/spectrum analyzer is 1MHz and the video bandwidth is 10Hz for Average detection (AV) at frequency above 1GHz.
4. All modes of operation were investigated and the worst-case emissions are reported.

### 4.2.4 DEVIATION FROM TEST STANDARD

No deviation

## 4.2.5 TEST SETUP

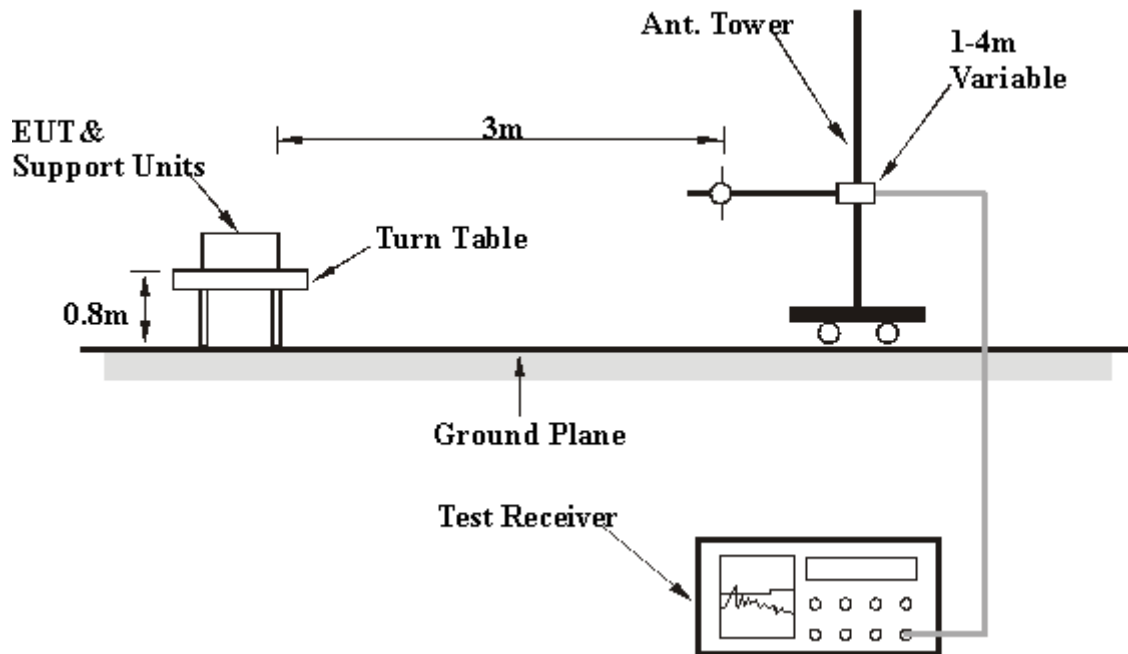

For the actual test configuration, please refer to the attached file (Test Setup Photo).

## 4.2.6 EUT OPERATING CONDITIONS

Set the EUT under transmission condition continuously at specific channel frequency.



A D T

## 4.2.7 TEST RESULTS

### ABOVE 1GHz DATA

EUT TEST CONDITION		MEASUREMENT DETAIL	
CHANNEL	Channel 1	FREQUENCY RANGE	1 ~ 25GHz
INPUT POWER (SYSTEM)	120Vac, 60Hz	DETECTOR FUNCTION	Peak (PK) Average (AV)
ENVIRONMENTAL CONDITIONS	26deg. C, 59%RH 1009hPa	TESTED BY	Nick Chen

ANTENNA POLARITY & TEST DISTANCE: HORIZONTAL AT 3 M								
NO.	FREQ. (MHz)	EMISSION LEVEL (dBuV/m)	LIMIT (dBuV/m)	MARGIN (dB)	ANTENNA HEIGHT (m)	TABLE ANGLE (Degree)	RAW VALUE (dBuV)	CORRECTION FACTOR (dB/m)
1	2390.00	57.9 PK	74.0	-16.1	1.00 H	144	26.01	31.89
2	2390.00	46.3 AV	54.0	-7.7	1.00 H	144	14.43	31.89
3	2400.00	41.7 PK	74.0	-32.4	1.00 H	144	9.72	31.93
4	2400.00	32.7 AV	54.0	-21.4	1.00 H	144	0.72	31.93
5	*2403.00	86.8 PK			1.00 H	144	54.81	31.94
6	*2403.00	77.8 AV			1.00 H	144	45.81	31.94
7	4806.00	54.5 PK	74.0	-19.5	1.00 H	224	15.44	39.08
8	4806.00	45.5 AV	54.0	-8.5	1.00 H	224	6.44	39.08
9	7209.00	58.3 PK	74.0	-15.7	1.00 H	235	13.03	45.28
10	7209.00	49.3 AV	54.0	-4.7	1.00 H	235	4.02	45.28

- REMARKS:**
1. Emission level (dBuV/m) = Raw Value (dBuV) + Correction Factor (dB/m).
  2. Correction Factor (dB/m) = Antenna Factor (dB/m) + Cable Factor (dB).
  3. The other emission levels were very low against the limit.
  4. Margin value = Emission level – Limit value.
  5. “ \* ” : Fundamental frequency
  6. The average value of fundamental frequency is: Average = Peak value + 20log(Duty cycle) Where the duty factor is calculated from following formula:  

$$20 \log (\text{Duty cycle}) = 20 \log ((17.78 \text{ ms} \times 2) / 100 \text{ ms}) = -9.0 \text{ dB}$$
 Please see page 24 for plotted duty.



A D T

EUT TEST CONDITION		MEASUREMENT DETAIL	
CHANNEL	Channel 1	FREQUENCY RANGE	1 ~ 25GHz
INPUT POWER (SYSTEM)	120Vac, 60Hz	DETECTOR FUNCTION	Peak (PK) Average (AV)
ENVIRONMENTAL CONDITIONS	26deg. C, 59%RH 1009hPa	TESTED BY	Nick Chen

ANTENNA POLARITY & TEST DISTANCE: VERTICAL AT 3 M								
NO.	FREQ. (MHz)	EMISSION LEVEL (dBuV/m)	LIMIT (dBuV/m)	MARGIN (dB)	ANTENNA HEIGHT (m)	TABLE ANGLE (Degree)	RAW VALUE (dBuV)	CORRECTION FACTOR (dB/m)
1	2390.00	59.5 PK	74.0	-14.5	1.00 V	170	27.58	31.89
2	2390.00	46.4 AV	54.0	-7.6	1.00 V	170	14.49	31.89
3	2400.00	33.4 PK	74.0	-40.6	1.00 V	170	1.47	31.93
4	2400.00	24.4 AV	54.0	-29.6	1.00 V	170	-7.53	31.93
5	*2403.00	78.5 PK			1.00 V	170	46.56	31.94
6	*2403.00	69.5 AV			1.00 V	170	37.56	31.94
7	4806.00	50.7 PK	74.0	-23.3	1.00 V	136	11.59	39.08
8	4806.00	41.7 AV	54.0	-12.3	1.00 V	136	2.59	39.08
9	7209.00	56.0 PK	74.0	-18.1	1.00 V	207	10.68	45.28
10	7209.00	47.0 AV	54.0	-7.1	1.00 V	207	1.67	45.28

- REMARKS:**
1. Emission level (dBuV/m) = Raw Value (dBuV) + Correction Factor (dB/m).
  2. Correction Factor (dB/m) = Antenna Factor (dB/m) + Cable Factor (dB).
  3. The other emission levels were very low against the limit.
  4. Margin value = Emission level – Limit value.
  5. “ \* ” : Fundamental frequency
  6. The average value of fundamental frequency is: Average = Peak value + 20log(Duty cycle) Where the duty factor is calculated from following formula:  
 $20 \log (\text{Duty cycle}) = 20 \log ((17.78 \text{ ms} \times 2) / 100 \text{ ms}) = -9.0 \text{ dB}$   
 Please see page 24 for plotted duty.



A D T

EUT TEST CONDITION		MEASUREMENT DETAIL	
CHANNEL	Channel 38	FREQUENCY RANGE	1 ~ 25GHz
INPUT POWER (SYSTEM)	120Vac, 60Hz	DETECTOR FUNCTION	Peak (PK) Average (AV)
ENVIRONMENTAL CONDITIONS	26deg. C, 59%RH 1009hPa	TESTED BY	Nick Chen

ANTENNA POLARITY & TEST DISTANCE: HORIZONTAL AT 3 M								
NO.	FREQ. (MHz)	EMISSION LEVEL (dBuV/m)	LIMIT (dBuV/m)	MARGIN (dB)	ANTENNA HEIGHT (m)	TABLE ANGLE (Degree)	RAW VALUE (dBuV)	CORRECTION FACTOR (dB/m)
1	*2440.00	89.0 PK			1.00 H	145	56.97	32.07
2	*2440.00	80.0 AV			1.00 H	145	47.97	32.07
3	4880.00	54.0 PK	74.0	-20.0	1.05 H	228	14.58	39.41
4	4880.00	45.0 AV	54.0	-9.0	1.05 H	228	5.58	39.41
5	7320.00	58.6 PK	74.0	-15.4	1.00 H	229	13.18	45.41
6	7320.00	49.6 AV	54.0	-4.4	1.00 H	229	4.18	45.41
ANTENNA POLARITY & TEST DISTANCE: VERTICAL AT 3 M								
NO.	FREQ. (MHz)	EMISSION LEVEL (dBuV/m)	LIMIT (dBuV/m)	MARGIN (dB)	ANTENNA HEIGHT (m)	TABLE ANGLE (Degree)	RAW VALUE (dBuV)	CORRECTION FACTOR (dB/m)
1	*2440.00	79.5 PK			1.00 V	182	47.43	32.07
2	*2440.00	70.5 AV			1.00 V	182	38.43	32.07
3	4880.00	51.9 PK	74.0	-22.1	1.14 V	144	12.47	39.41
4	4880.00	42.9 AV	54.0	-11.1	1.14 V	144	3.47	39.41
5	7320.00	56.1 PK	74.0	-17.9	1.63 V	212	10.68	45.41
6	7320.00	47.1 AV	54.0	-6.9	1.63 V	212	1.68	45.41

- REMARKS:**
1. Emission level (dBuV/m) = Raw Value (dBuV) + Correction Factor (dB/m).
  2. Correction Factor (dB/m) = Antenna Factor (dB/m) + Cable Factor (dB).
  3. The other emission levels were very low against the limit.
  4. Margin value = Emission level – Limit value.
  5. “ \* ” : Fundamental frequency
  6. The average value of fundamental frequency is: Average = Peak value + 20log(Duty cycle) Where the duty factor is calculated from following formula:  
 $20 \log (\text{Duty cycle}) = 20 \log ((17.78 \text{ ms} \times 2) / 100 \text{ ms}) = -9.0 \text{ dB}$   
 Please see page 24 for plotted duty.



A D T

EUT TEST CONDITION		MEASUREMENT DETAIL	
CHANNEL	Channel 77	FREQUENCY RANGE	1 ~ 25GHz
INPUT POWER (SYSTEM)	120Vac, 60Hz	DETECTOR FUNCTION	Peak (PK) Average (AV)
ENVIRONMENTAL CONDITIONS	26deg. C, 59%RH 1009hPa	TESTED BY	Nick Chen

ANTENNA POLARITY & TEST DISTANCE: HORIZONTAL AT 3 M								
NO.	FREQ. (MHz)	EMISSION LEVEL (dBuV/m)	LIMIT (dBuV/m)	MARGIN (dB)	ANTENNA HEIGHT (m)	TABLE ANGLE (Degree)	RAW VALUE (dBuV)	CORRECTION FACTOR (dB/m)
1	*2479.00	89.2 PK			1.00 H	226	57.04	32.20
2	*2479.00	80.2 AV			1.00 H	226	48.04	32.20
3	2483.50	43.8 PK	74.0	-30.2	1.00 H	226	11.63	32.21
4	2483.50	34.8 AV	54.0	-19.2	1.00 H	226	2.63	32.21
5	4958.00	52.5 PK	74.0	-21.5	1.00 H	227	12.86	39.66
6	4958.00	43.5 AV	54.0	-10.5	1.00 H	227	3.86	39.66
7	7437.00	58.5 PK	74.0	-15.5	1.00 H	224	13.08	45.41
8	7437.00	49.5 AV	54.0	-4.5	1.00 H	224	4.09	45.41
ANTENNA POLARITY & TEST DISTANCE: VERTICAL AT 3 M								
NO.	FREQ. (MHz)	EMISSION LEVEL (dBuV/m)	LIMIT (dBuV/m)	MARGIN (dB)	ANTENNA HEIGHT (m)	TABLE ANGLE (Degree)	RAW VALUE (dBuV)	CORRECTION FACTOR (dB/m)
1	*2479.00	82.4 PK			1.03 V	162	50.24	32.20
2	*2479.00	73.4 AV			1.03 V	162	41.24	32.20
3	2483.50	37.0 PK	74.0	-37.0	1.03 V	162	4.83	32.21
4	2483.50	28.0 AV	54.0	-26.0	1.03 V	162	-4.17	32.21
5	4958.00	50.9 PK	74.0	-23.1	1.00 V	152	11.28	39.66
6	4958.00	41.9 AV	54.0	-12.1	1.00 V	152	2.28	39.66
7	7437.00	54.9 PK	74.0	-19.1	1.00 V	190	9.51	45.41
8	7437.00	45.9 AV	54.0	-8.1	1.00 V	190	0.52	45.41

- REMARKS:**
1. Emission level (dBuV/m) = Raw Value (dBuV) + Correction Factor (dB/m).
  2. Correction Factor (dB/m) = Antenna Factor (dB/m) + Cable Factor (dB).
  3. The other emission levels were very low against the limit.
  4. Margin value = Emission level – Limit value.
  5. “ \* “ : Fundamental frequency
  6. The average value of fundamental frequency is: Average = Peak value + 20log(Duty cycle) Where the duty factor is calculated from following formula:  
 $20 \log (\text{Duty cycle}) = 20 \log ((17.78 \text{ ms} \times 2) / 100 \text{ ms}) = -9.0 \text{ dB}$   
 Please see page 24 for plotted duty.



A D T

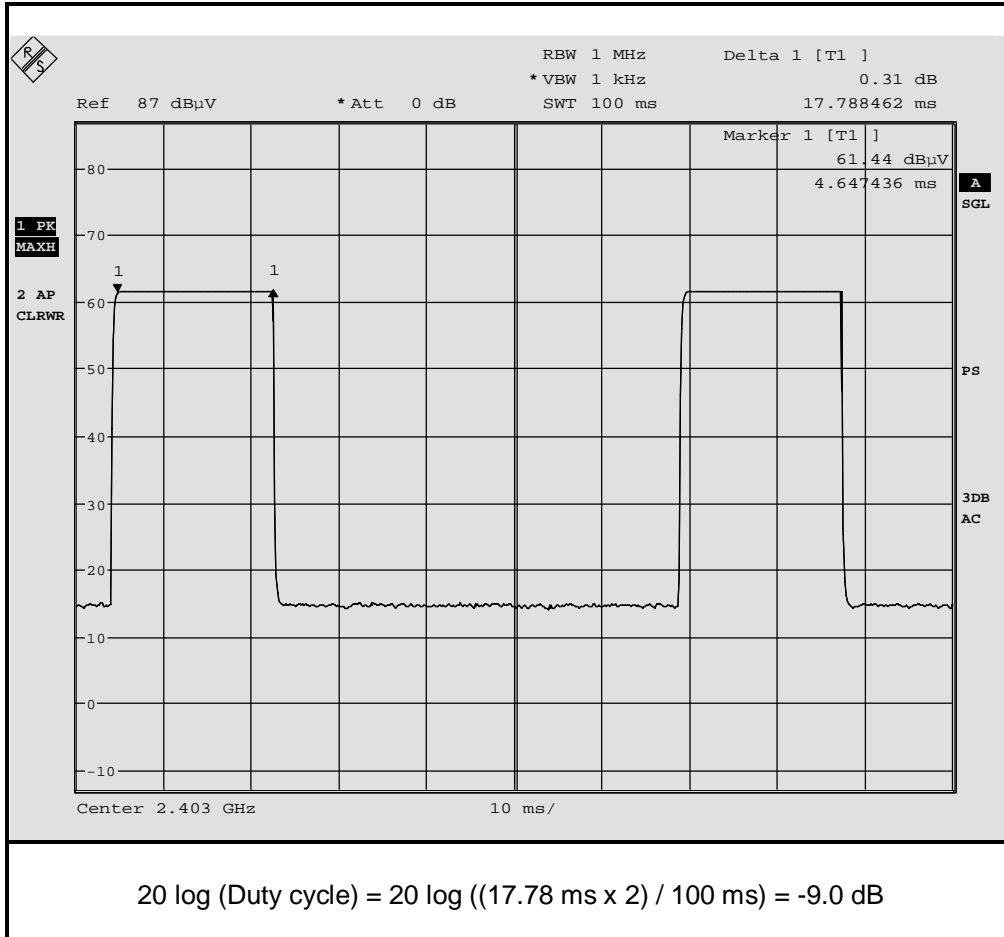





A D T

**BELOW 1GHz WORST-CASE DATA**

EUT TEST CONDITION		MEASUREMENT DETAIL	
CHANNEL	Channel 1	FREQUENCY RANGE	Below 1000MHz
INPUT POWER (SYSTEM)	120Vac, 60Hz	DETECTOR FUNCTION	Quasi-Peak
ENVIRONMENTAL CONDITIONS	26deg. C, 59%RH 1009hPa	TESTED BY	Nick Chen

ANTENNA POLARITY & TEST DISTANCE: HORIZONTAL AT 3 M								
NO.	FREQ. (MHz)	EMISSION LEVEL (dBuV/m)	LIMIT (dBuV/m)	MARGIN (dB)	ANTENNA HEIGHT (m)	TABLE ANGLE (Degree)	RAW VALUE (dBuV)	CORRECTION FACTOR (dB/m)
1	70.42	32.8 QP	40.0	-7.2	1.04 H	94	20.61	12.15
2	154.36	32.6 QP	43.5	-11.0	1.11 H	103	18.30	14.25
3	228.97	41.2 QP	46.0	-4.8	1.08 H	241	28.68	12.54
4	536.76	34.8 QP	46.0	-11.3	1.26 H	118	12.96	21.79
5	637.80	34.2 QP	46.0	-11.8	1.09 H	352	10.34	23.89
6	675.11	34.5 QP	46.0	-11.5	1.27 H	187	10.05	24.46
7	712.42	34.9 QP	46.0	-11.1	1.26 H	355	9.93	25.01
8	751.28	40.2 QP	46.0	-5.8	1.16 H	10	14.62	25.55
ANTENNA POLARITY & TEST DISTANCE: VERTICAL AT 3 M								
NO.	FREQ. (MHz)	EMISSION LEVEL (dBuV/m)	LIMIT (dBuV/m)	MARGIN (dB)	ANTENNA HEIGHT (m)	TABLE ANGLE (Degree)	RAW VALUE (dBuV)	CORRECTION FACTOR (dB/m)
1	107.72	31.7 QP	43.5	-11.8	1.12 V	43	21.39	10.34
2	152.80	30.8 QP	43.5	-12.7	1.03 V	343	16.73	14.03
3	233.64	38.6 QP	46.0	-7.4	1.27 V	85	25.81	12.80
4	466.81	33.5 QP	46.0	-12.6	1.32 V	358	13.66	19.79
5	535.21	34.9 QP	46.0	-11.1	1.18 V	349	13.18	21.75
6	637.80	32.4 QP	46.0	-13.6	1.03 V	328	8.55	23.89
7	751.28	38.4 QP	46.0	-7.6	1.07 V	10	12.88	25.55
8	863.21	32.8 QP	46.0	-13.2	1.50 V	355	5.46	27.35

- REMARKS:**
1. Emission level (dBuV/m) = Raw Value (dBuV) + Correction Factor (dB/m).
  2. Correction Factor (dB/m) = Antenna Factor (dB/m) + Cable Factor (dB).
  3. The other emission levels were very low against the limit.
  4. Margin value = Emission level – Limit value.



A D T

## 4.3 6dB BANDWIDTH MEASUREMENT

### 4.3.1 LIMITS OF 6dB BANDWIDTH MEASUREMENT

The minimum of 6dB Bandwidth Measurement is 0.5 MHz.

### 4.3.2 TEST INSTRUMENTS

DESCRIPTION & MANUFACTURER	MODEL NO.	SERIAL NO.	CALIBRATED DATE	CALIBRATED UNTIL
SPECTRUM ANALYZER	FSP 40	100036	Apr. 27, 2010	Apr. 26, 2011

**NOTE:** The calibration interval of the above test instruments is 12 months and the calibrations are traceable to NML/ROC and NIST/USA.

### 4.3.3 TEST PROCEDURE

The transmitter output was connected to the spectrum analyzer through an attenuator. The bandwidth of the fundamental frequency was measured by spectrum analyzer with 100kHz RBW and 300kHz VBW. The 6dB bandwidth is defined as the total spectrum the power of which is higher than peak power minus 6dB.

### 4.3.4 DEVIATION FROM TEST STANDARD

No deviation

### 4.3.5 TEST SETUP

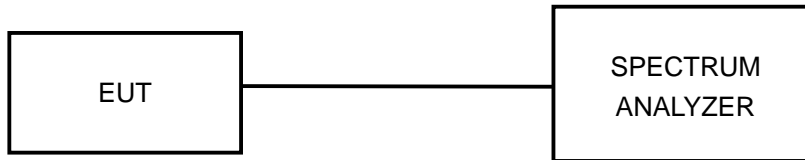

### 4.3.6 EUT OPERATING CONDITIONS

The software provided by client to enable the EUT under transmission condition continuously at lowest, middle and highest channel frequencies individually.



A D T

### 4.3.7 TEST RESULTS

CHANNEL	CHANNEL FREQUENCY (MHz)	6dB BANDWIDTH (MHz)	MINIMUM LIMIT (MHz)	PASS / FAIL
1	2403	0.82	0.5	PASS
38	2440	0.83	0.5	PASS
77	2479	0.83	0.5	PASS

#### CH 38

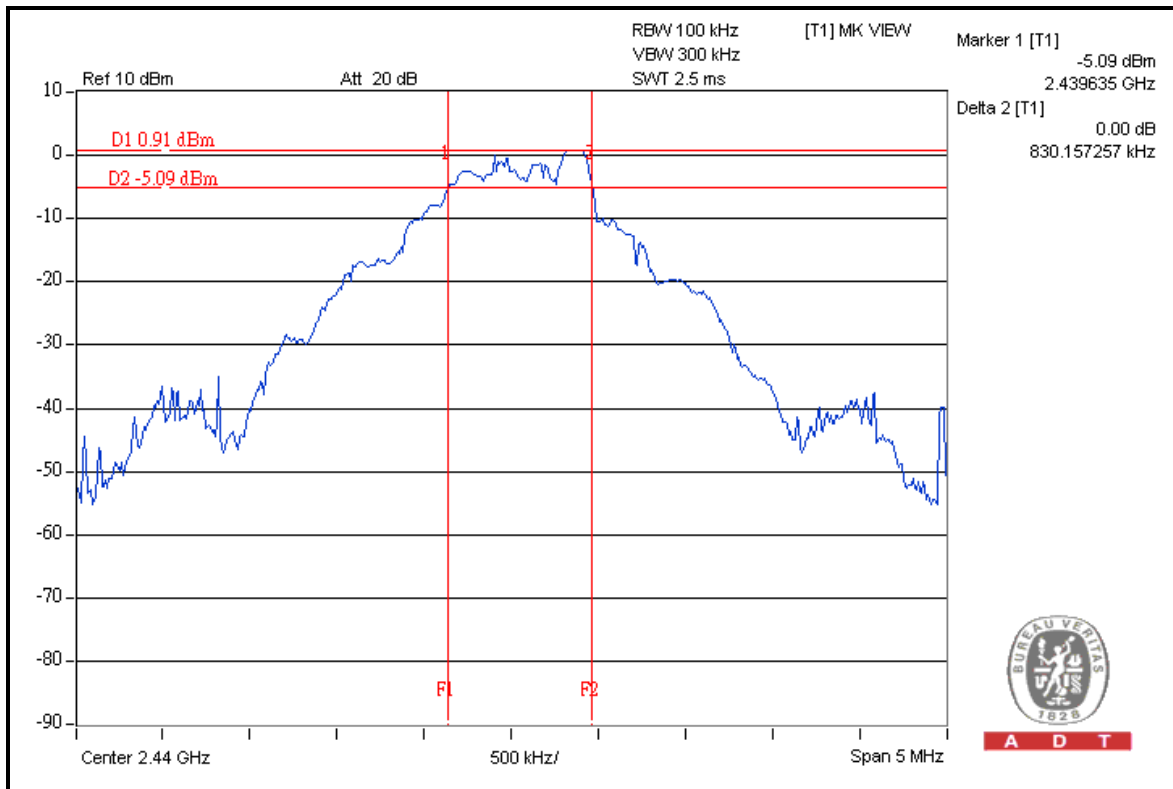



A D T

## 4.4 MAXIMUM OUTPUT POWER

### 4.4.1 LIMITS OF MAXIMUM PEAK OUTPUT POWER MEASUREMENT

The Maximum Output Power Measurement is 30dBm.

### 4.4.2 INSTRUMENTS

DESCRIPTION & MANUFACTURER	MODEL NO.	SERIAL NO.	CALIBRATED DATE	CALIBRATED UNTIL
SPECTRUM ANALYZER	FSP 40	100036	Apr. 27, 2010	Apr. 26, 2011

**NOTE:** The calibration interval of the above test instruments is 12 months and the calibrations are traceable to NML/ROC and NIST/USA.

### 4.4.3 TEST PROCEDURES

1. Check the calibration of the measuring instrument using either an internal calibrator or a known signal from an external generator.
2. Turn on the EUT and connect it to measurement instrument. Then set it to any one convenient frequency within its operating range. Set a reference level on the measuring instrument equal to the highest peak value.
3. The center frequency of the spectrum analyzer is set to the fundamental frequency and using 3 MHz RBW and 10 MHz VBW, the peak value was measured and recorded.
4. Repeat above procedures until all frequencies measured were complete.

Note: The spectrum plots are attached on following pages.



A D T

#### 4.4.4 DEVIATION FROM TEST STANDARD

No deviation

#### 4.4.5 TEST SETUP

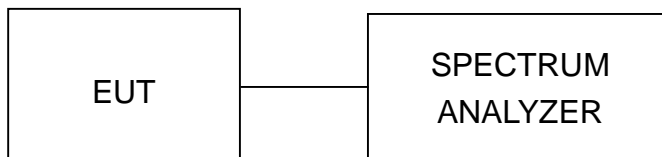

#### 4.4.6 EUT OPERATING CONDITIONS

Same as Item 4.3.6



A D T

### 4.4.7 TEST RESULTS

CHANNEL	CHANNEL FREQUENCY (MHz)	PEAK OUTPUT POWER (dBm)	PEAK OUTPUT POWER (mW)	PEAK OUTPUT POWER (dBm)	PASS / FAIL
1	2403	1.2	1.3	30	PASS
38	2440	1.1	1.3	30	PASS
77	2479	0.7	1.2	30	PASS

#### CH 1

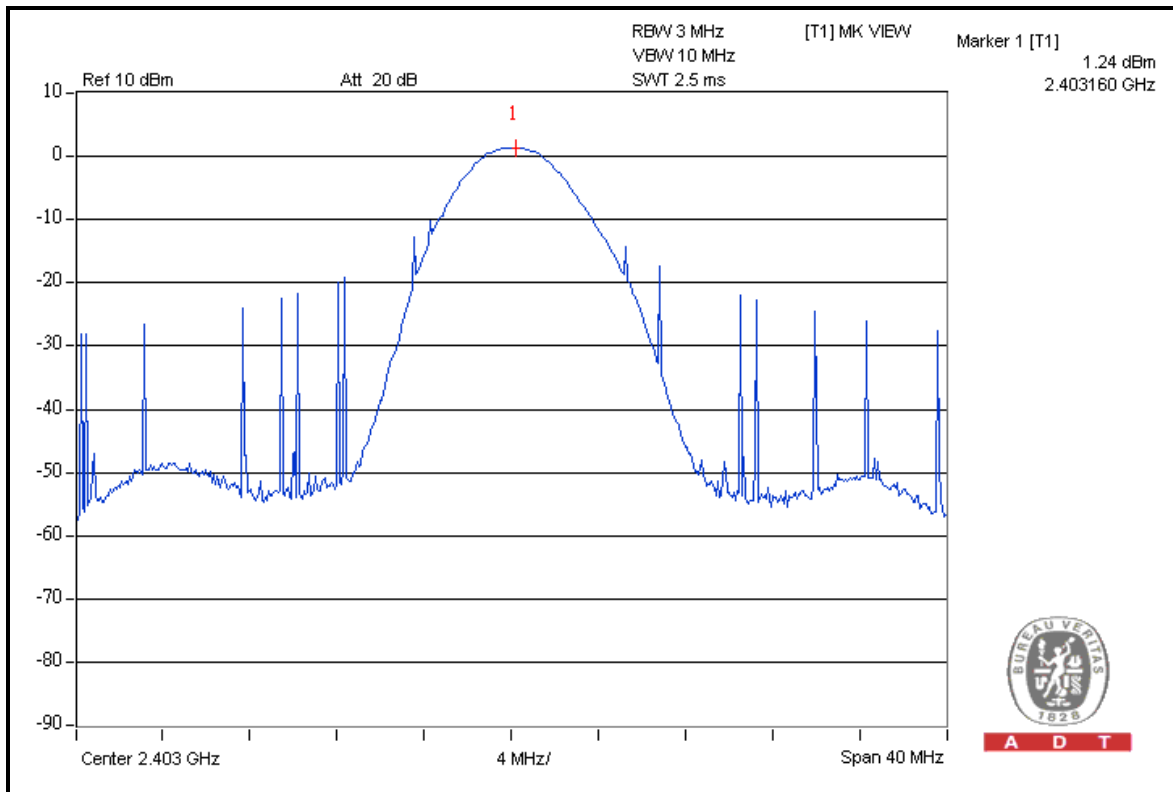



A D T

## 4.5 POWER SPECTRAL DENSITY MEASUREMENT

### 4.5.1 LIMITS OF POWER SPECTRAL DENSITY MEASUREMENT

The Maximum of Power Spectral Density Measurement is 8dBm.

### 4.5.2 TEST INSTRUMENTS

DESCRIPTION & MANUFACTURER	MODEL NO.	SERIAL NO.	CALIBRATED DATE	CALIBRATED UNTIL
SPECTRUM ANALYZER	FSP 40	100036	Apr. 27, 2010	Apr. 26, 2011

**NOTE:** The calibration interval of the above test instruments is 12 months and the calibrations are traceable to NML/ROC and NIST/USA.

### 4.5.3 TEST PROCEDURE

The transmitter output was connected to the spectrum analyzer through an attenuator, the bandwidth of the fundamental frequency was measured with the spectrum analyzer using 3kHz RBW and 30kHz VBW, set sweep time = span/3kHz. The power spectral density was measured and recorded.

The sweep time is allowed to be longer than span/3kHz for a full response of the mixer in the spectrum analyzer.





A D T

#### 4.5.4 DEVIATION FROM TEST STANDARD

No deviation

#### 4.5.5 TEST SETUP

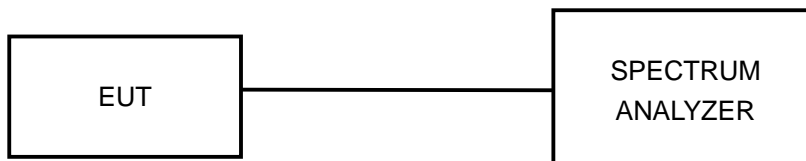

#### 4.5.6 EUT OPERATING CONDITION

Same as Item 4.3.6





A D T

## 4.6 BAND EDGES MEASUREMENT

### 4.6.1 LIMITS OF BAND EDGES MEASUREMENT

Below  $-20\text{dB}$  of the highest emission level of operating band (in 100kHz Resolution Bandwidth).

### 4.6.2 TEST INSTRUMENTS

DESCRIPTION & MANUFACTURER	MODEL NO.	SERIAL NO.	CALIBRATED DATE	CALIBRATED UNTIL
SPECTRUM ANALYZER	FSP 40	100036	Apr. 27, 2010	Apr. 26, 2011

**NOTE:** The calibration interval of the above test instruments is 12 months and the calibrations are traceable to NML/ROC and NIST/USA.

### 4.6.3 TEST PROCEDURE

The transmitter output was connected to the spectrum analyzer via a low lose cable. Set RBW and VBW of spectrum analyzer to 100 kHz and 300 kHz suitable frequency span including 100 MHz bandwidth from band edge. The band edges was measured and recorded.

The spectrum plots (Peak RBW=100kHz, VBW=300kHz; Average RBW=1MHz, VBW= 1kHz) are attached on the following pages.

### 4.6.4 DEVIATION FROM TEST STANDARD

No deviation

### 4.6.5 EUT OPERATING CONDITION

Same as Item 4.3.6



#### 4.6.6 TEST RESULTS

The spectrum plots are attached on the following pages. D1 line indicates the highest level, and D2 line indicates the 20dB offset below D1. It shows compliance with the requirement in part 15.247(d).

##### RESTRICT BAND (2310 ~ 2390 MHz)

FREQUENCY (MHz)	FUNDAMENTAL EMISSION (dBuV/m)	DELTA (dB)	MAXIMUM FIELD STRENGTH IN RESTRICT BAND (dBuV/m)	LIMIT (dBuV/m)
2403.00 (PK)	86.8	57.1	29.7	74.00
2403.00 (AV)	77.8	67.0	10.8	54.00

##### RESTRICT BAND (2483.5 ~ 2500 MHz)

FREQUENCY (MHz)	FUNDAMENTAL EMISSION (dBuV/m)	DELTA (dB)	MAXIMUM FIELD STRENGTH IN RESTRICT BAND (dBuV/m)	LIMIT (dBuV/m)
2479.00 (PK)	89.2	46.7	42.5	74.00
2479.00 (AV)	80.2	47.8	32.4	54.00

**NOTE:**

1. Delta = Amplitude between the peak of the fundamental and the peak of the band edge emission. Please check following 3 pages.
2. Maximum field strength in restrict band = Fundamental emission – Delta.



A D T

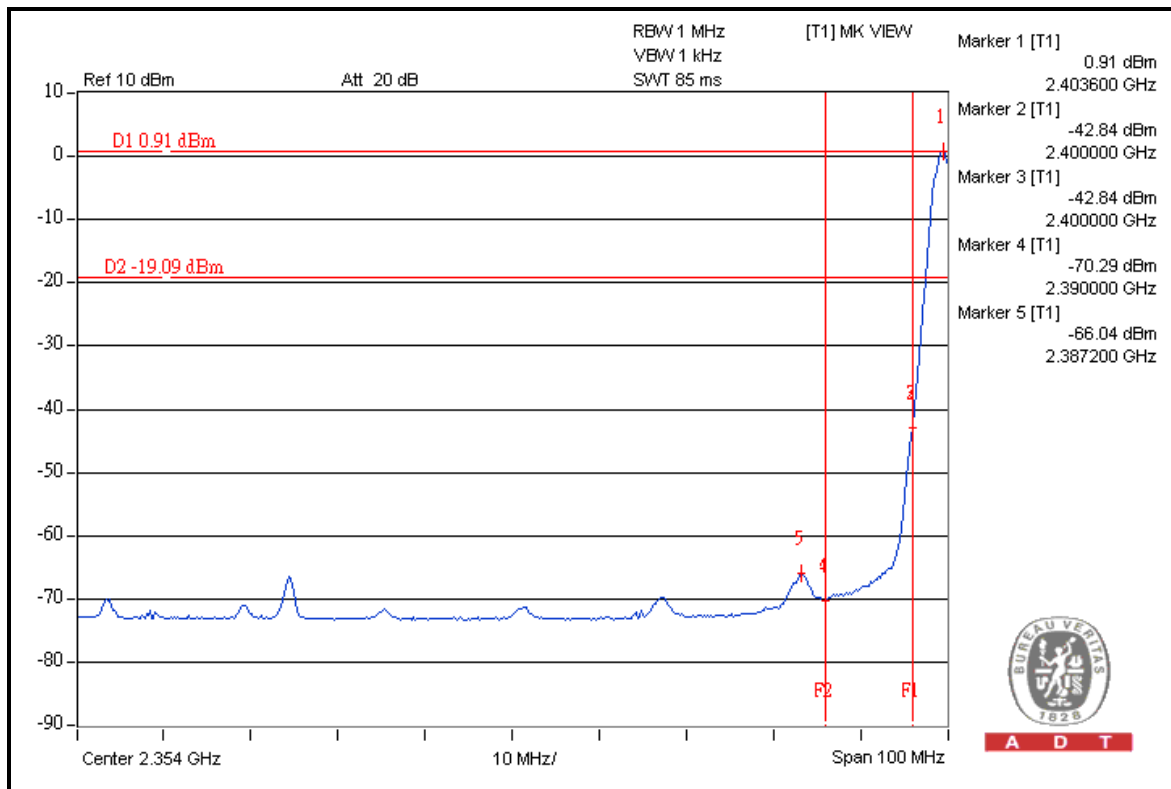
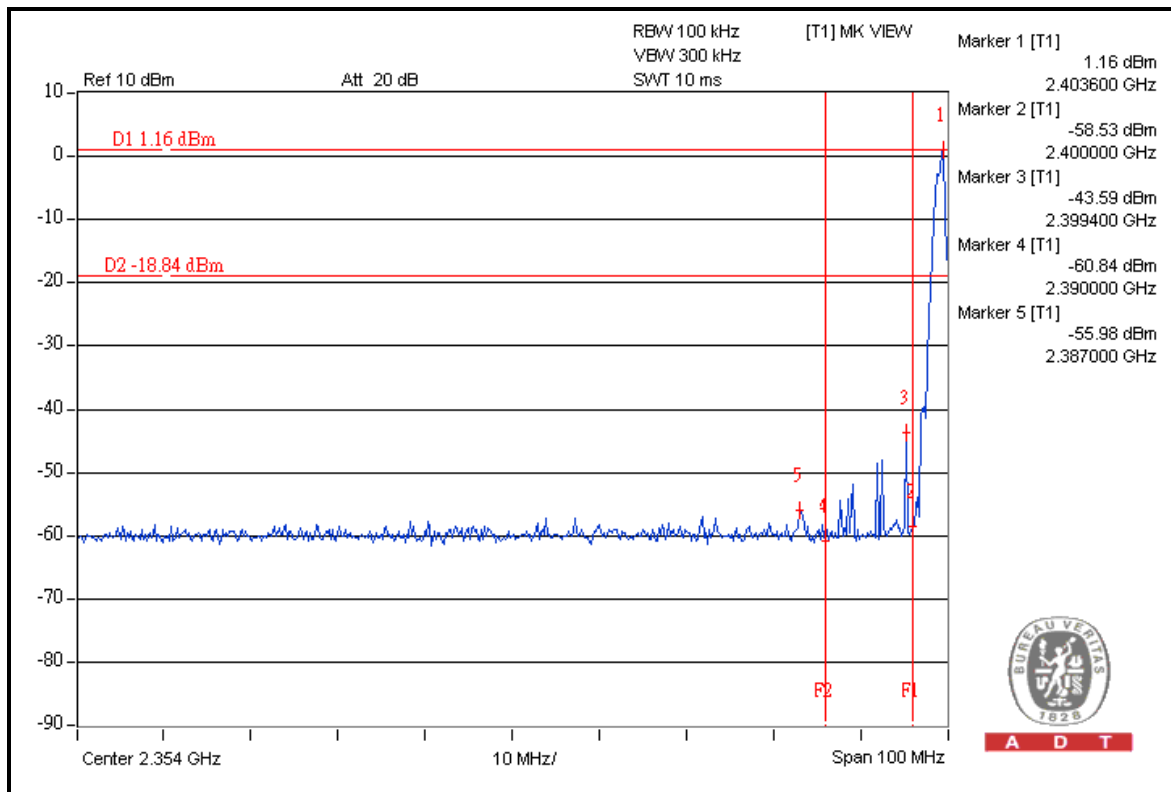



A D T

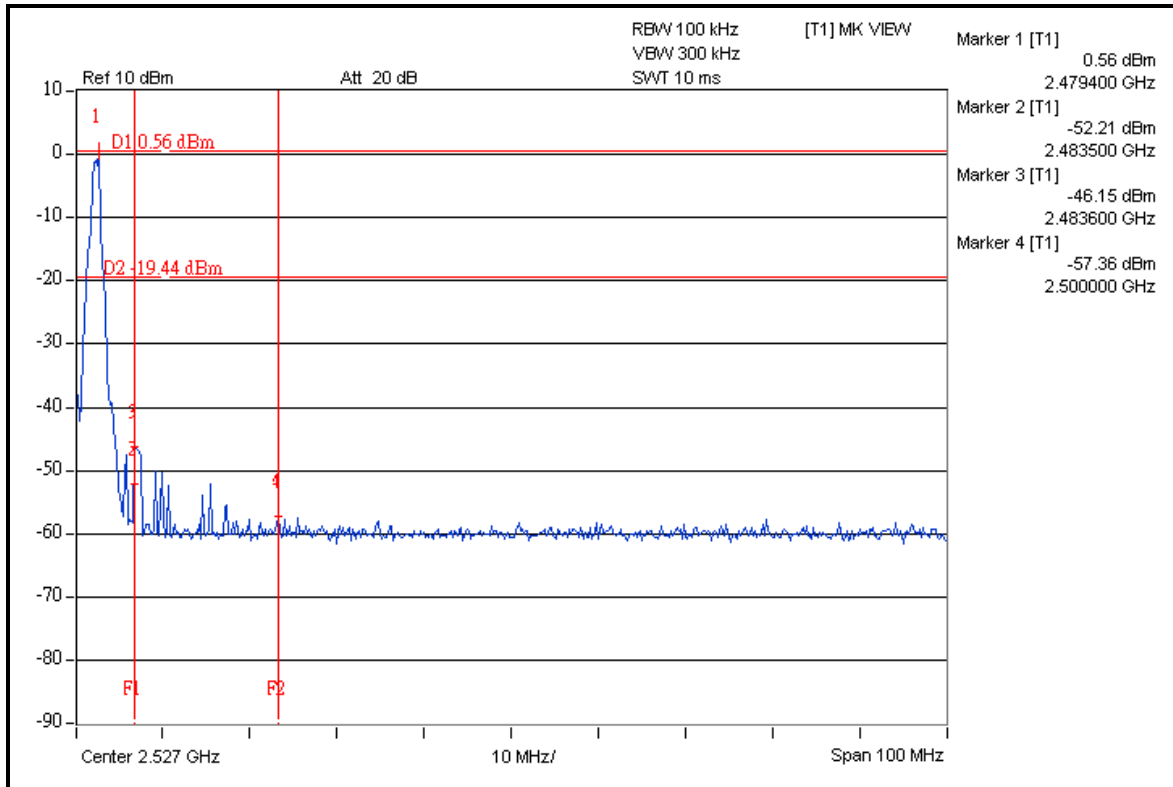
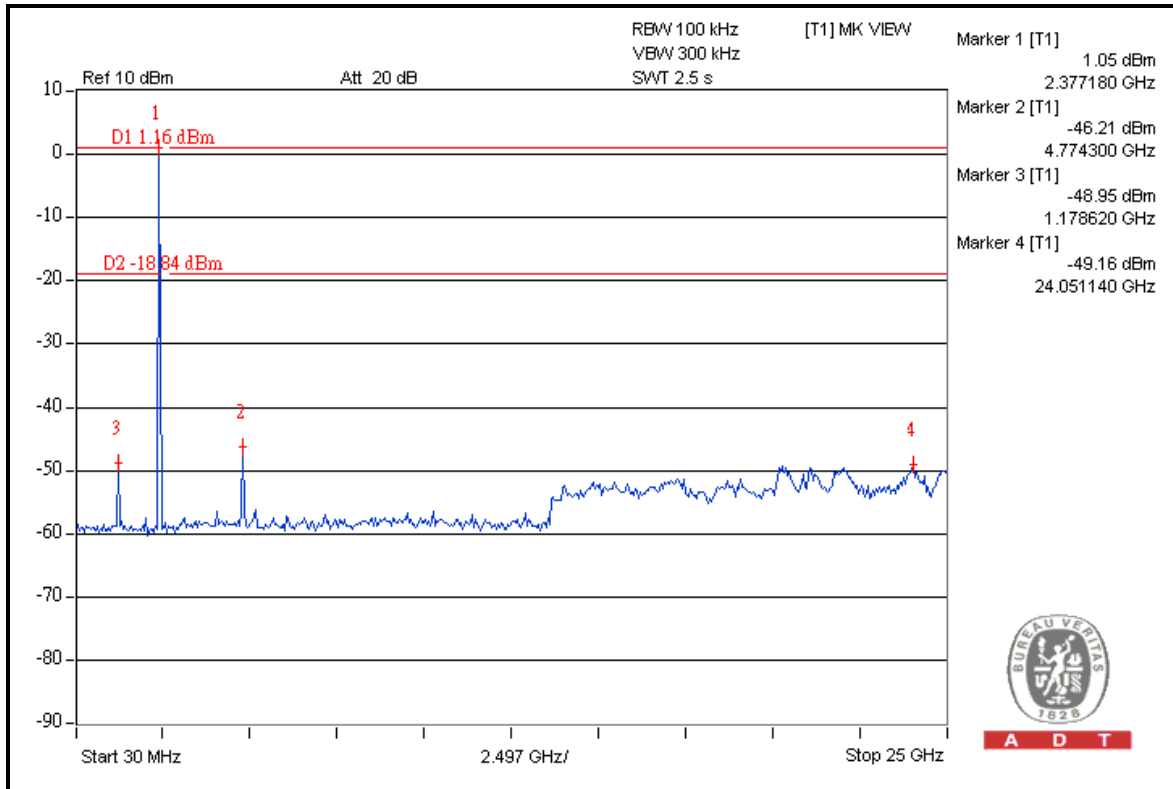



A D T

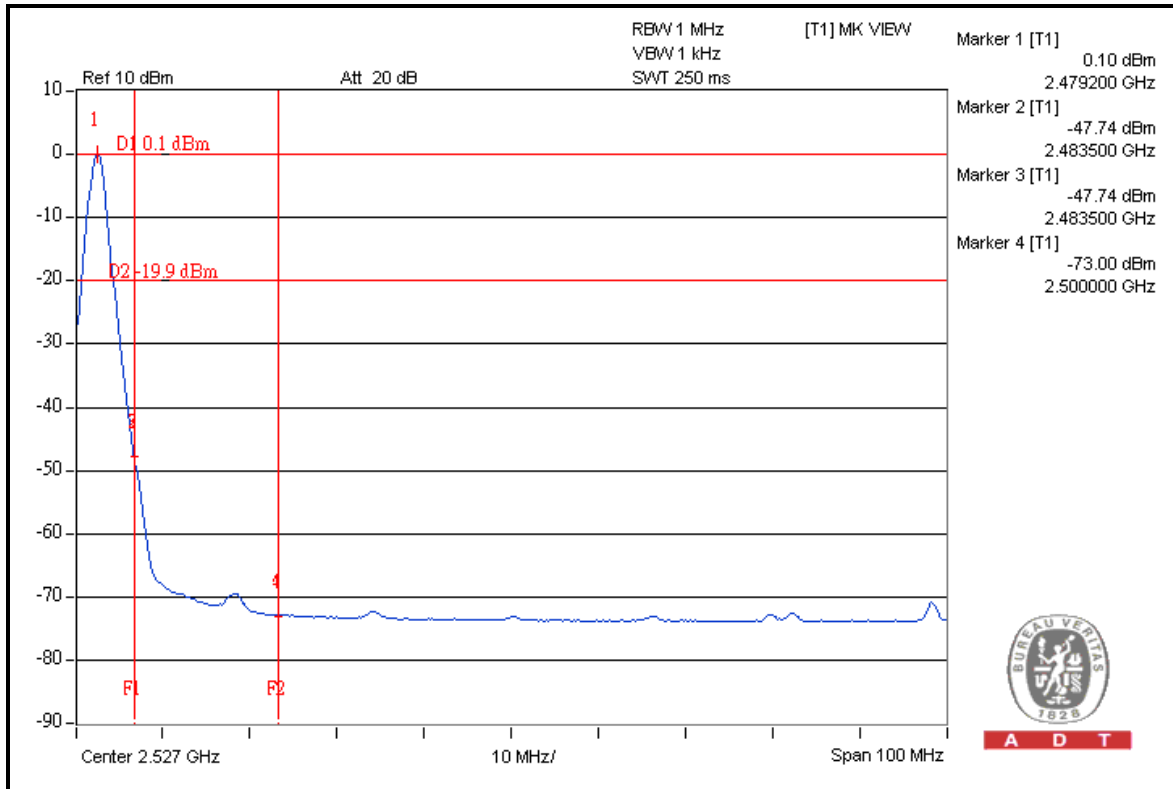

A D T

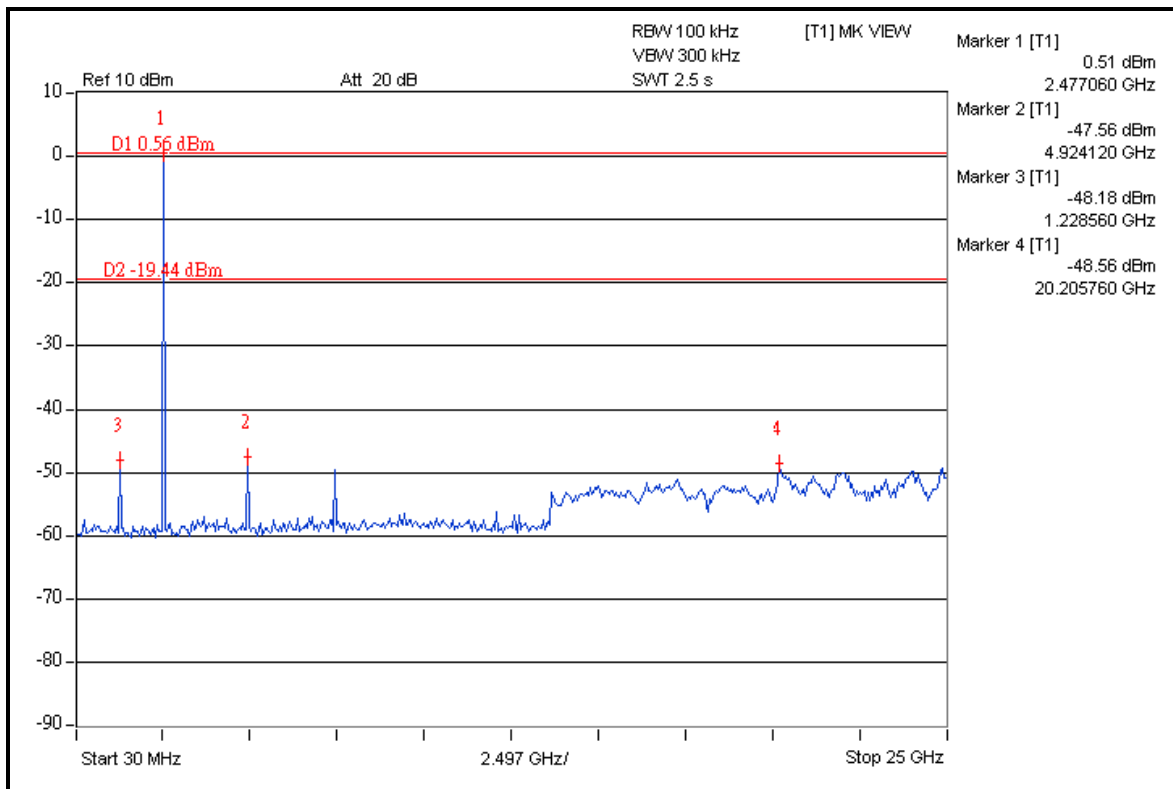



A D T

## 5. PHOTOGRAPHS OF THE TEST CONFIGURATION

Please refer to the attached file (Test Setup Photo).





A D T

## 6. INFORMATION ON THE TESTING LABORATORIES

We, Bureau Veritas Consumer Products Services (H.K.) Ltd., Taoyuan Branch, were founded in 1988 to provide our best service in EMC, Radio, Telecom and Safety consultation. Our laboratories are accredited and approved according to ISO/IEC 17025.

Copies of accreditation certificates of our laboratories obtained from approval agencies can be downloaded from our web site: [www.adt.com.tw/index.5/phtml](http://www.adt.com.tw/index.5/phtml).  
If you have any comments, please feel free to contact us at the following:

**Linko EMC/RF Lab:**

Tel: 886-2-26052180

Fax: 886-2-26051924

**Hsin Chu EMC/RF Lab:**

Tel: 886-3-5935343

Fax: 886-3-5935342

**Hwa Ya EMC/RF/Safety / Telecom Lab:**

Tel: 886-3-3183232

Fax: 886-3-3185050

**Web Site:** [www.adt.com.tw](http://www.adt.com.tw)

The address and road map of all our labs can be found in our web site also.



A D T

## **7. APPENDIX A - MODIFICATIONS RECORDERS FOR ENGINEERING CHANGES TO THE EUT BY THE LAB**

No any modifications are made to the EUT by the lab during the test.

**---END---**