



Test Report

Product Name	HP Slate Bluetooth Keyboard
Model No.	HSTNN-DK01
FCC ID.	O62HNDK01

Applicant	Darfon Electronics Corp
Address	167, Shanying Road, Gueishan, Taoyuan 33341, Taiwan R.O.C

Date of Receipt	Feb. 11, 2011
Issued Date	Sep. 21, 2011
Report No.	118231R-RFUSP43V01-C
Report Version	V1.0

The Test Results relate only to the samples tested.

The test report shall not be reproduced except in full without the written approval of Quietek Corporation.

This report must not be used to claim product endorsement by NVLAP any agency of the U.S. Government

Test Report Certification

Issued Date: Sep. 21, 2011

Report No.: 118231R-RFUSP43V01-C



Product Name	HP Slate Bluetooth Keyboard
Applicant	Darfon Electronics Corp
Address	167, Shanying Road, Gueishan, Taoyuan 33341, Taiwan R.O.C
Manufacturer	Darfon Electronics (Suzhou) Co., Ltd.
Model No.	HSTNN-DK01
FCC ID.	O62HNDK01
EUT Rated Voltage	DC 3.7V (Power by Battery)
EUT Test Voltage	DC 3.7V (Power by Battery)
Trade Name	HP
Applicable Standard	FCC CFR Title 47 Part 15 Subpart C: 2010 ANSI C63.4: 2009
Test Result	Complied



The Test Results relate only to the samples tested.
 The test report shall not be reproduced except in full without the written approval of Quietek Corporation.
 This report must not be used to claim product endorsement by NVLAP any agency of the U.S. Government

Documented By : Leven Huang
 (Senior Adm. Specialist / Leven Huang)



Tested By : Sabrina Tsai
 (Engineer / Sabrina Tsai)



Approved By : Vincent Lin
 (Manager / Vincent Lin)

TABLE OF CONTENTS

Description	Page
1. GENERAL INFORMATION	5
1.1. EUT Description.....	5
1.2. Operational Description.....	7
1.3. Tested System Details.....	8
1.4. Configuration of Tested System	9
1.5. EUT Exercise Software	10
1.6. Test Facility	11
2. CONDUCTED EMISSION	12
2.1. Test Equipment.....	12
2.2. Test Setup	12
2.3. Limits.....	13
2.4. Test Procedure	13
2.5. Uncertainty	13
2.6. Test Result of Conducted Emission.....	14
3. PEAK POWER OUTPUT	16
3.1. Test Equipment.....	16
3.2. Test Setup	16
3.3. Limit	16
3.4. Test Procedure	16
3.5. Uncertainty	16
3.6. Test Result of Peak Power Output.....	17
4. RADIATED EMISSION	18
4.1. Test Equipment.....	18
4.2. Test Setup	18
4.3. Limits.....	19
4.4. Test Procedure	20
4.5. Uncertainty	20
4.6. Test Result of Radiated Emission.....	21
5. RF ANTENNA CONDUCTED TEST	25
5.1. Test Equipment.....	25
5.2. Test Setup	25
5.3. Limits.....	25
5.4. Test Procedure	25
5.5. Uncertainty	25
5.6. Test Result of RF Antenna Conducted Test.....	26
6. BAND EDGE	29
6.1. Test Equipment.....	29
6.2. Test Setup	30
6.3. Limit	31
6.4. Test Procedure	31
6.5. Uncertainty	31
6.6. Test Result of Band Edge	32
7. CHANNEL NUMBER.....	36
7.1. Test Equipment.....	36
7.2. Test Setup	36
7.3. Limit	36
7.4. Test Procedure	36
7.5. Uncertainty	36
7.6. Test Result of Channel Number.....	37
8. CHANNEL SEPARATION.....	39
8.1. Test Equipment.....	39
8.2. Test Setup	39
8.3. Limit	39
8.4. Test Procedure	39
8.5. Uncertainty	39
8.6. Test Result of Channel Separation.....	40
9. DWELL TIME.....	42
9.1. Test Equipment.....	42

9.2.	Test Setup	42
9.3.	Limit	42
9.4.	Test Procedure	42
9.5.	Uncertainty	42
9.6.	Test Result of Dwell Time	43
10.	OCCUPIED BANDWIDTH	45
10.1.	Test Equipment	45
10.2.	Test Setup	45
10.3.	Limits	45
10.4.	Test Procedure	45
10.5.	Uncertainty	45
10.6.	Test Result of Occupied Bandwidth	46
11.	EMI REDUCTION METHOD DURING COMPLIANCE TESTING	49

Attachment 1: EUT Test Photographs

Attachment 2: EUT Detailed Photographs

1. GENERAL INFORMATION

1.1. EUT Description

Product Name	HP Slate Bluetooth Keyboard
Trade Name	HP
Model No.	HSTNN-DK01
FCC ID.	O62HNDK01
Frequency Range	2402 – 2480MHz
Channel Number	79
Type of Modulation	FHSS: GFSK (1Mbps)
Antenna Type	Printed on PCB
Channel Control	Auto
Antenna Gain	Refer to the table “Antenna List”
USB Cable	Non-shielded, 0.8m

Antenna List

No.	Manufacturer	Part No.	Antenna Type	Peak Gain
1	Darfon	N/A	Printed on PCB	0.42 dBi in 2.4 GHz

Note: The antenna of EUT is conform to FCC 15.203

Frequency of Each Channel:

Channel	Frequency	Channel	Frequency	Channel	Frequency	Channel	Frequency
Channel 00:	2402 MHz	Channel 20:	2422 MHz	Channel 40:	2442 MHz	Channel 60:	2462 MHz
Channel 01:	2403 MHz	Channel 21:	2423 MHz	Channel 41:	2443 MHz	Channel 61:	2463 MHz
Channel 02:	2404 MHz	Channel 22:	2424 MHz	Channel 42:	2444 MHz	Channel 62:	2464 MHz
Channel 03:	2405 MHz	Channel 23:	2425 MHz	Channel 43:	2445 MHz	Channel 63:	2465 MHz
Channel 04:	2406 MHz	Channel 24:	2426 MHz	Channel 44:	2446 MHz	Channel 64:	2466 MHz
Channel 05:	2407 MHz	Channel 25:	2427 MHz	Channel 45:	2447 MHz	Channel 65:	2467 MHz
Channel 06:	2408 MHz	Channel 26:	2428 MHz	Channel 46:	2448 MHz	Channel 66:	2468 MHz
Channel 07:	2409 MHz	Channel 27:	2429 MHz	Channel 47:	2449 MHz	Channel 67:	2469 MHz
Channel 08:	2410 MHz	Channel 28:	2430 MHz	Channel 48:	2450 MHz	Channel 68:	2470 MHz
Channel 09:	2411 MHz	Channel 29:	2431 MHz	Channel 49:	2451 MHz	Channel 69:	2471 MHz
Channel 10:	2412 MHz	Channel 30:	2432 MHz	Channel 50:	2452 MHz	Channel 70:	2472 MHz
Channel 11:	2413 MHz	Channel 31:	2433 MHz	Channel 51:	2453 MHz	Channel 71:	2473 MHz
Channel 12:	2414 MHz	Channel 32:	2434 MHz	Channel 52:	2454 MHz	Channel 72:	2474 MHz
Channel 13:	2415 MHz	Channel 33:	2435 MHz	Channel 53:	2455 MHz	Channel 73:	2475 MHz
Channel 14:	2416 MHz	Channel 34:	2436 MHz	Channel 54:	2456 MHz	Channel 74:	2476 MHz
Channel 15:	2417 MHz	Channel 35:	2437 MHz	Channel 55:	2457 MHz	Channel 75:	2477 MHz
Channel 16:	2418 MHz	Channel 36:	2438 MHz	Channel 56:	2458 MHz	Channel 76:	2478 MHz
Channel 17:	2419 MHz	Channel 37:	2439 MHz	Channel 57:	2459 MHz	Channel 77:	2479 MHz
Channel 18:	2420 MHz	Channel 38:	2440 MHz	Channel 58:	2460 MHz	Channel 78:	2480 MHz
Channel 19:	2421 MHz	Channel 39:	2441 MHz	Channel 59:	2461 MHz		

Note:

1. This device is a HP Slate Bluetooth Keyboard with a built-in 2.4GHz Bluetooth V2.0 transceiver.
2. These tests were conducted on a sample for the purpose of demonstrating compliance of Bluetooth transmitter with Part 15 Subpart C Paragraph 15.247 for spread spectrum devices.
3. Regarding to the operation frequency, the lowest, middle and highest frequency are selected to perform the test.

1.2. Operational Description

The EUT is a HP Slate Bluetooth Keyboard with built-in 2.4GHz Bluetooth V2.0 transceiver. The number of the channels is 79 in 2402-2480MHz. The device adapts the frequency hopping spread spectrum modulation. The antenna is printed on PCB and provides diversity function to improve the receiving function.

The system receivers have input bandwidths that match the hopping channel bandwidths of their corresponding transmitters and shift frequencies in synchronization with the transmitted signals

Frequency hopping spread spectrum systems are not required to employ all available hopping channels during each transmission. The transmitter is presented with a continuous data stream. In addition, a system employing short transmission bursts must comply with the definition of a frequency hopping system and must distribute its 79 channels and over the minimum number of hopping channels (75 channels).

The incorporation of intelligence within a frequency hopping spread spectrum system that permits the system to recognize other users within the spectrum band so that it individually and independently chooses and adapts its hopsets to avoid hopping on occupied channels is permitted. The coordination of frequency hopping systems in any other manner for the express purpose of avoiding the simultaneous occupancy of individual hopping frequencies by multiple transmitters is not permitted.

This device is only GFSK modulation (1Mbps) function.

Test Mode	Mode 1: Transmit - 1Mbps (GFSK)
-----------	---------------------------------

1.3. Tested System Details

The types for all equipment, plus descriptions of all cables used in the tested system (including inserted cards) are:

Product	Manufacturer	Model No.	Serial No.	FCC ID	Power Cord
1 Fixture	Darfon	N/A	N/A	N/A	N/A
2 Notebook PC	DELL	PPT	N/A	DoC	Non-Shielded, 0.8m
3 Monitor	Dell	2407WFPb	CN-0YY528-46633-796-12TS	DoC	Non-Shielded, 1.8m
4 DVD-ROM	Dell	PD01S	N/A	N/A	N/A
5 Microphone & Earphone	Ergotech	ET-E201	N/A	N/A	N/A

	Signal Cable Type	Signal cable Description
A	Signal Cable	Non-shielded, 0.5m
B	RS-232 Cable	Non-shielded, 1.8m
C	USB Cable	Non-shielded, 1.0m, with one ferrite core bonded.
D	VGA Cable	Shielded, 1.8m, with two ferrite cores bonded.
E	USB Cable	Non-shielded, 1.2m
F	Microphone & Earphone Cable	Non-shielded, 1.0m

1.4. Configuration of Tested System

For Conducted Emission

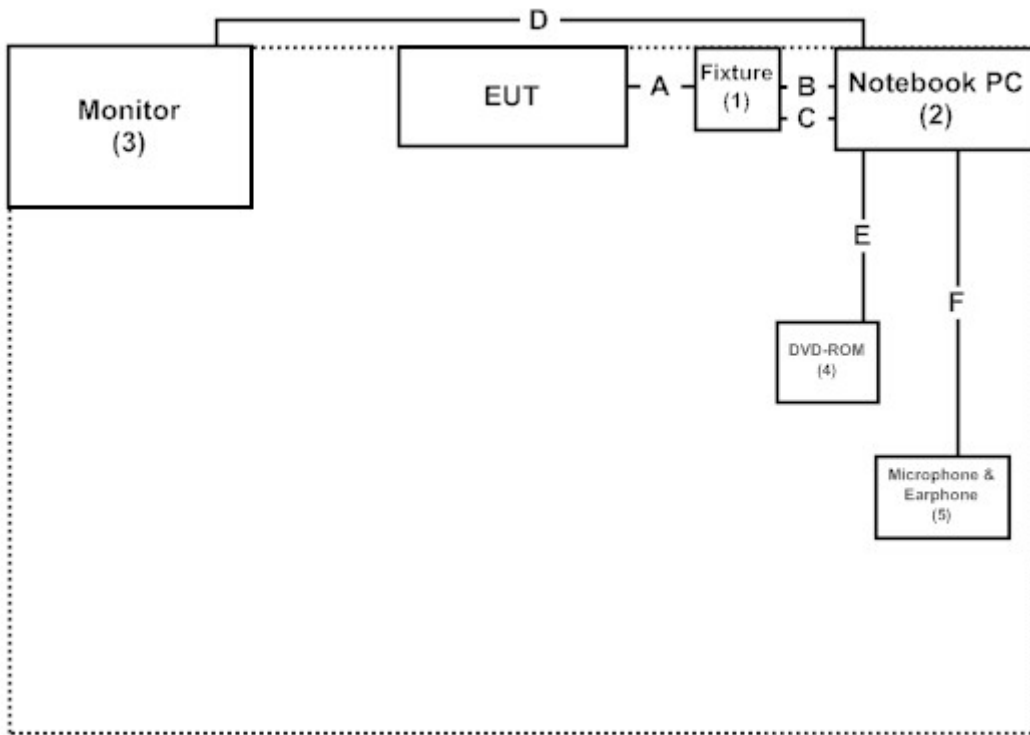

For Radiated Emission

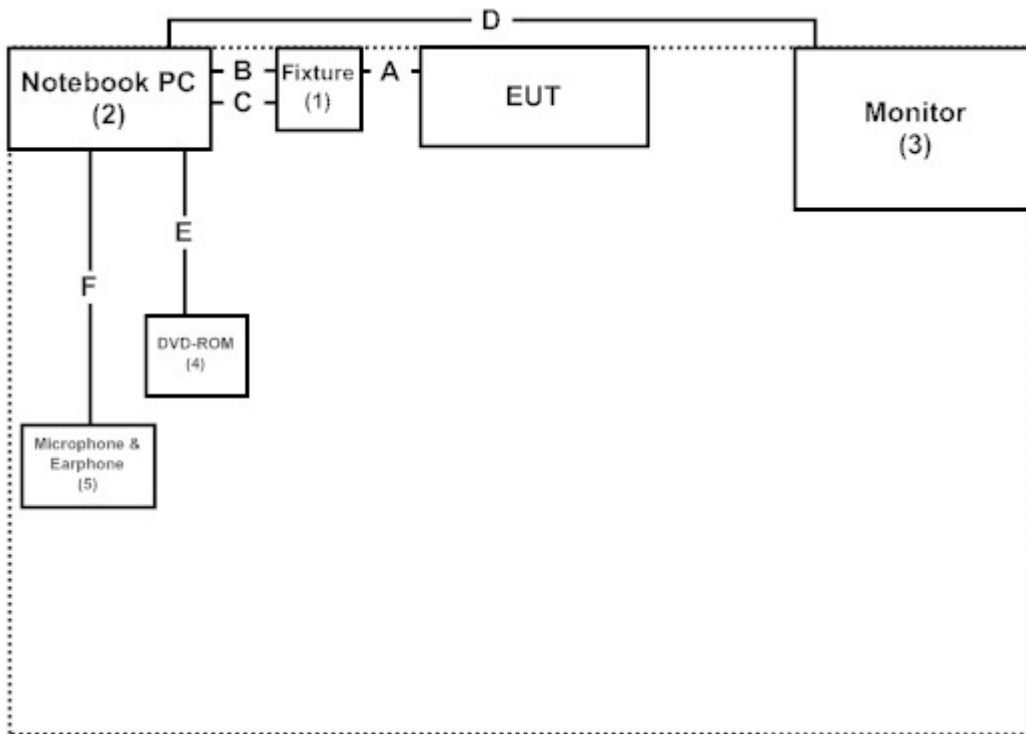

1.5. EUT Exercise Software

- (1) Connect EUT and Notebook via test fixture.
- (2) Execute test program (Blue tool) on the Notebook.
- (3) Configure the test mode, the test channel.
- (4) Press “OK” to start the continuous transmission.
- (5) Verify that the EUT works properly.

1.6. Test Facility

Ambient conditions in the laboratory:

Items	Required (IEC 68-1)	Actual
Temperature (°C)	15-35	20-35
Humidity (%RH)	25-75	30-65
Barometric pressure (mbar)	860-1060	950-1000

The related certificate for our laboratories about the test site and management system can be downloaded from Quietek Corporation’s Web Site: <http://www.quietek.com/tw/ctg/cts/accreditations.htm>
 The address and introduction of Quietek Corporation’s laboratories can be founded in our Web site: <http://www.quietek.com/>

Site Description: File on
 Federal Communications Commission
 FCC Engineering Laboratory
 7435 Oakland Mills Road
 Columbia, MD 21046
 Registration Number: 92195



Accreditation on NVLAP
 NVLAP Lab Code: 200533-0



Site Name: Quietek Corporation
 Site Address: No. 5-22, Rueishu Keng,
 Linkou Dist., New Taipei City 24451,
 Taiwan, R.O.C.
 TEL: 886-2-8601-3788 / FAX : 886-2-8601-3789
 E-Mail : service@quietek.com

FCC Accreditation Number: TW1014



2. Conducted Emission

2.1. Test Equipment

The following test equipment are used during the conducted emission test:

Item	Instrument	Manufacturer	Type No./Serial No	Last Cal.	Remark
1	Test Receiver	R & S	ESCS 30/825442/014	Feb., 2011	
2	L.I.S.N.	R & S	ESH3-Z5/825562/002	Feb., 2011	EUT
3	L.I.S.N.	R & S	ENV4200/848411/010	Feb., 2011	Peripherals
4	Pulse Limiter	R & S	ESH3-Z2/100410	July, 2011	
5	No.1 Shielded Room			N/A	

Note: All instruments are calibrated every one year.

2.2. Test Setup

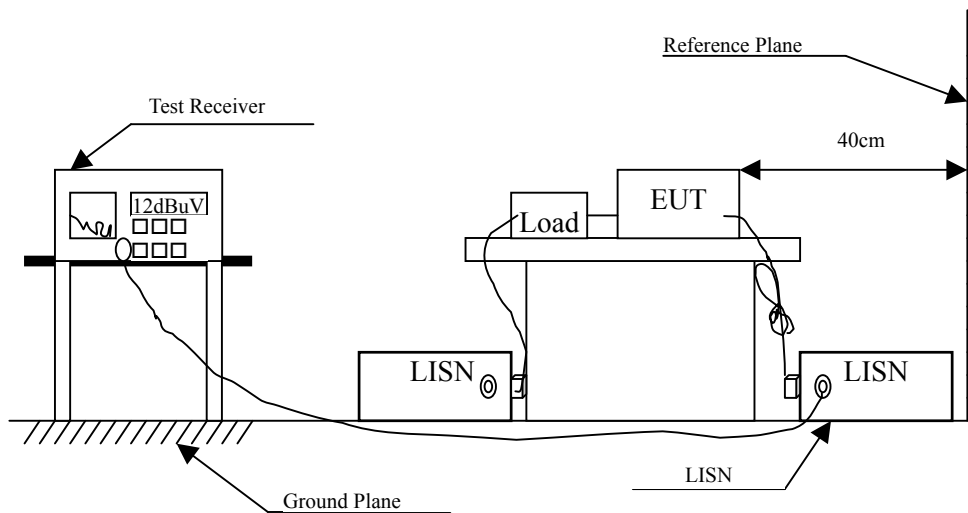

2.3. Limits

FCC Part 15 Subpart C Paragraph 15.207 (dBuV) Limit		
Frequency MHz	Limits	
	QP	AV
0.15 - 0.50	66-56	56-46
0.50-5.0	56	46
5.0 - 30	60	50

Remarks: In the above table, the tighter limit applies at the band edges.

2.4. Test Procedure

The EUT and Peripherals are connected to the main power through a line impedance stabilization network (L.I.S.N.). This provides a 50 ohm /50uH coupling impedance for the measuring equipment. The peripheral devices are also connected to the main power through a LISN that provides a 50ohm /50uH coupling impedance with 50ohm termination. (Please refer to the block diagram of the test setup and photographs.)

Both sides of A.C. line are checked for maximum conducted interference. In order to find the maximum emission, the relative positions of equipment and all the interface cables must be changed according to ANSI C63.4: 2009 on conducted measurement.

Conducted emissions were investigated over the frequency range from 0.15MHz to 30MHz using a receiver bandwidth of 9kHz.

The EUT was setup to ANSI C63.4, 2009; tested to FHSS test procedure of FCC Public Notice DA 00-705 for compliance to FCC 47CFR 15.247 requirements.

2.5. Uncertainty

± 2.26 dB

2.6. Test Result of Conducted Emission

Product : HP Slate Bluetooth Keyboard
 Test Item : Conducted Emission Test
 Power Line : Line 1
 Test Mode : Mode 1: Transmit - 1Mbps (GFSK)

Frequency MHz	Correct Factor dB	Reading Level dBuV	Measurement Level dBuV	Margin dB	Limit dBuV
LINE 1					
Quasi-Peak					
0.150	9.766	28.660	38.426	-27.574	66.000
0.185	9.719	36.710	46.429	-18.571	65.000
0.240	9.680	34.770	44.450	-18.979	63.429
0.279	9.657	26.660	36.317	-25.997	62.314
0.755	9.643	26.540	36.183	-19.817	56.000
4.127	9.700	27.910	37.610	-18.390	56.000
Average					
0.150	9.766	6.220	15.986	-40.014	56.000
0.185	9.719	25.330	35.049	-19.951	55.000
0.240	9.680	26.030	35.710	-17.719	53.429
0.279	9.657	5.280	14.937	-37.377	52.314
0.755	9.643	17.830	27.473	-18.527	46.000
4.127	9.700	18.410	28.110	-17.890	46.000

Note:

1. All Reading Levels are Quasi-Peak and average value.
2. "█" means the worst emission level.
3. Measurement Level = Reading Level + Correct Factor

Product : HP Slate Bluetooth Keyboard
 Test Item : Conducted Emission Test
 Power Line : Line 2
 Test Mode : Mode 1: Transmit - 1Mbps (GFSK)

Frequency MHz	Correct Factor dB	Reading Level dBuV	Measurement Level dBuV	Margin dB	Limit dBuV
LINE 2					
Quasi-Peak					
0.158	9.756	29.970	39.726	-26.045	65.771
0.181	9.732	39.020	48.752	-16.362	65.114
0.244	9.689	33.990	43.679	-19.635	63.314
0.302	9.660	33.220	42.880	-18.777	61.657
0.759	9.664	30.700	40.364	-15.636	56.000
4.127	9.700	25.640	35.340	-20.660	56.000
Average					
0.158	9.756	8.110	17.866	-37.905	55.771
0.181	9.732	27.360	37.092	-18.022	55.114
0.244	9.689	26.630	36.319	-16.995	53.314
0.302	9.660	22.890	32.550	-19.107	51.657
0.759	9.664	22.490	32.154	-13.846	46.000
4.127	9.700	17.710	27.410	-18.590	46.000

Note:

1. All Reading Levels are Quasi-Peak and average value.
2. "■" means the worst emission level.
3. Measurement Level = Reading Level + Correct Factor

3. Peak Power Output

3.1. Test Equipment

	Equipment	Manufacturer	Model No./Serial No.	Last Cal.
X	Power Meter	Anritsu	ML2495A/6K00003357	May, 2011
X	Power Sensor	Anritsu	MA2411B/0738448	Jun, 2011

Note: 1. All equipments are calibrated every one year.
 2. The test instruments marked by “X” are used to measure the final test results.

3.2. Test Setup

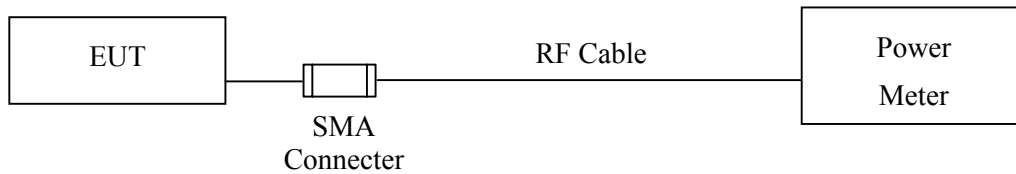

3.3. Limit

The maximum peak power shall be less 1Watt.

3.4. Test Procedure

The EUT was setup to ANSI C63.4, 2009; tested to FHSS test procedure of FCC Public Notice DA 00-705 for compliance to FCC 47CFR 15.247 requirements.

3.5. Uncertainty

± 1.27 dB

3.6. Test Result of Peak Power Output

Product : HP Slate Bluetooth Keyboard
Test Item : Peak Power Output
Test Site : No.3 OATS
Test Mode : Mode 1: Transmit - 1Mbps (GFSK)

Channel No.	Frequency (MHz)	Measurement (dBm)	Required Limit	Result
Channel 00	2402	0.84	1 Watt= 30 dBm	Pass
Channel 39	2441	0.99	1 Watt= 30 dBm	Pass
Channel 78	2480	1.94	1 Watt= 30 dBm	Pass

4. Radiated Emission

4.1. Test Equipment

The following test equipments are used during the radiated emission test:

Test Site		Equipment	Manufacturer	Model No./Serial No.	Last Cal.
☒ Site # 3	X	Bilog Antenna	Schaffner Chase	CBL6112B/2673	Sep., 2011
	X	Horn Antenna	Schwarzbeck	BBHA9120D/D305	Sep., 2011
	X	Horn Antenna	Schwarzbeck	BBHA9170/208	Jul., 2011
	X	Pre-Amplifier	Agilent	8447D/2944A09549	Sep., 2011
	X	Spectrum Analyzer	Agilent	E4407B / US39440758	May, 2011
	X	Test Receiver	R & S	ESCS 30/ 825442/018	Sep., 2011
	X	Coaxial Cable	Quietek	QTK-CABLE/ CAB5	Feb., 2011
	X	Controller	Quietek	QTK-CONTROLLER/ CTRL3	N/A
	X	Coaxial Switch	Anritsu	MP59B/6200265729	N/A

- Note: 1. All equipments are calibrated every one year.
 2. The test instruments marked by "X" are used to measure the final test results.

4.2. Test Setup

Below 1GHz

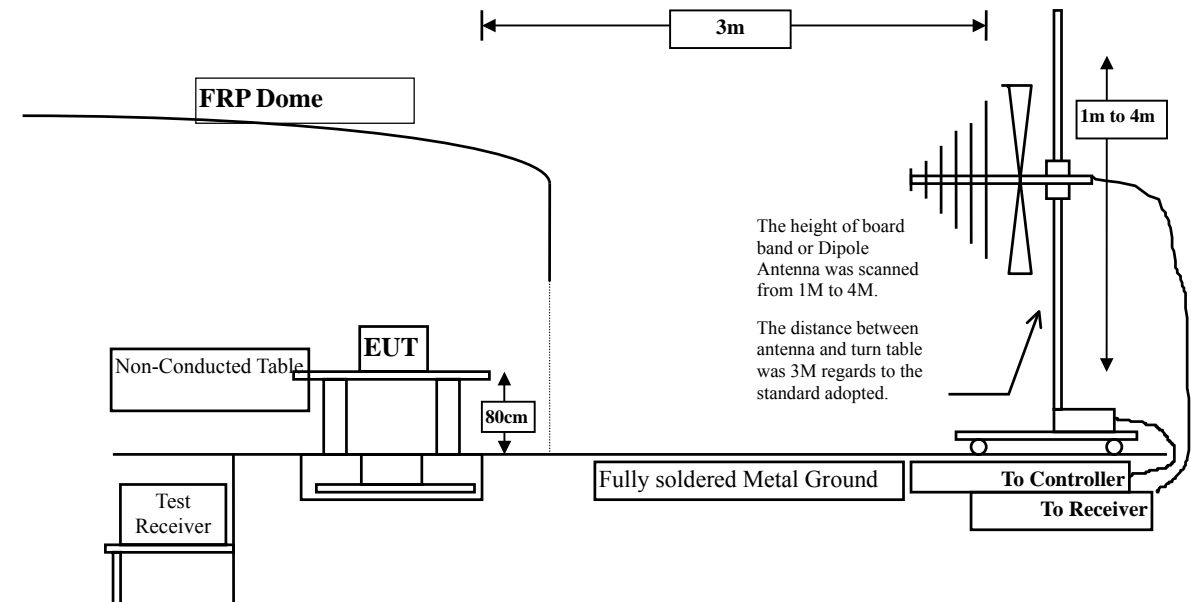

Above 1GHz

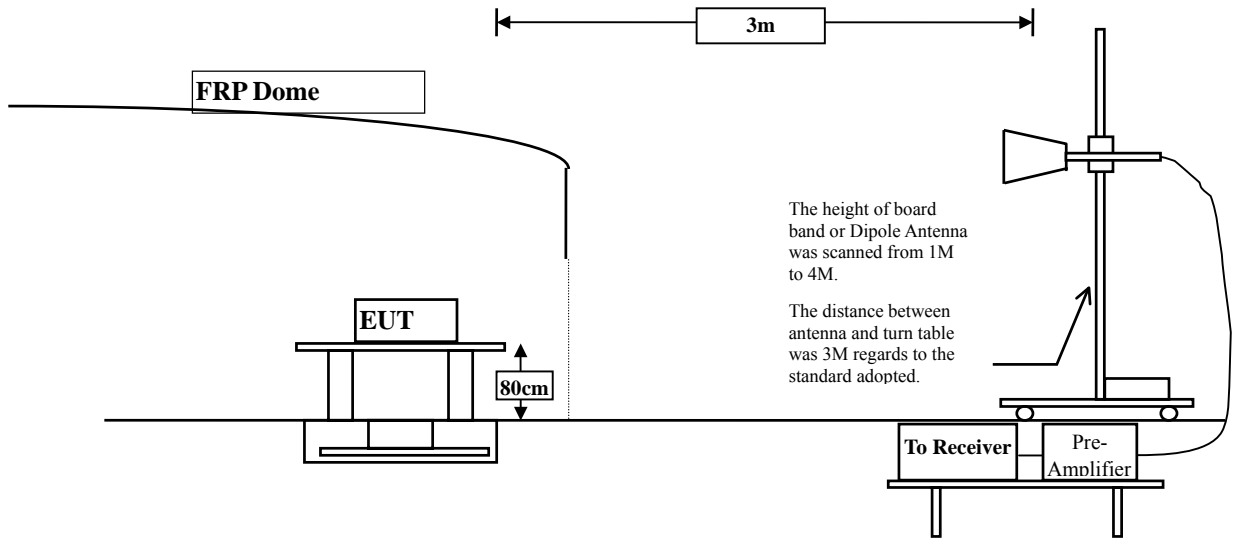

4.3. Limits

➤ General Radiated Emission Limits

Emissions radiated outside of the specified frequency bands, except for harmonics, shall be attenuated by at least 20dB below the level of the fundamental or to the general radiated emission limits in paragraph 15.209, whichever is the lesser attenuation.

FCC Part 15 Subpart C Paragraph 15.209 Limits		
Frequency MHz	uV/m @3m	dBuV/m@3m
30-88	100	40
88-216	150	43.5
216-960	200	46
Above 960	500	54

- Remarks:
1. RF Voltage (dBuV) = 20 log RF Voltage (uV)
 2. In the Above Table, the tighter limit applies at the band edges.
 3. Distance refers to the distance in meters between the measuring instrument antenna and the closed point of any part of the device or system.

4.4. Test Procedure

The EUT was setup according to ANSI C63.4, 2009 and tested according to FHSS test procedure of FCC Public Notice DA 00-705 for compliance to FCC 47CFR 15.247 requirements.

The EUT is placed on a turn table which is 0.8 meter above ground. The turn table is rotated 360 degrees to determine the position of the maximum emission level. The EUT was positioned such that the distance from antenna to the EUT was 3 meters.

The antenna is scanned from 1 meter to 4 meters to find out the maximum emission level. This is repeated for both horizontal and vertical polarization of the antenna. In order to find the maximum emission, all of the interface cables were manipulated according to ANSI C63.4:2009 on radiated measurement.

The resolution bandwidth below 1GHz setting on the field strength meter is 120 kHz and above 1GHz is 1MHz.

Radiated emission measurements below 1GHz are made using broadband Bilog antenna and above 1GHz are made using Horn Antennas.

The measurement is divided into the Preliminary Measurement and the Final Measurement.

The suspected frequencies are searched for in Preliminary Measurement with the measurement antenna kept pointed at the source of the emission both in azimuth and elevation, with the polarization of the antenna oriented for maximum response. The antenna is pointed at an angle towards the source of the emission, and the EUT is rotated in both height and polarization to maximize the measured emission. The emission is kept within the illumination area of the 3 dB bandwidth of the antenna.

The worst radiated emission is measured on the Final Measurement.

The measurement frequency range form 30MHz - 10th Harmonic of fundamental was investigated.

4.5. Uncertainty

± 3.9 dB above 1GHz

± 3.8 dB below 1GHz

4.6. Test Result of Radiated Emission

Product : HP Slate Bluetooth Keyboard
 Test Item : Harmonic Radiated Emission
 Test Site : No.3 OATS
 Test Mode : Mode 1: Transmit - 1Mbps (GFSK)(2402MHz)

Frequency MHz	Correct Factor dB	Reading Level dBuV	Measurement Level dBuV/m	Margin dB	Limit dBuV/m
Horizontal					
Peak Detector:					
4804.000	3.327	49.880	53.207	-20.793	74.000
7206.000	10.136	41.900	52.036	-21.964	74.000
9608.000	13.706	36.050	49.756	-24.244	74.000
Average Detector:					
--					
Vertical					
Peak Detector:					
4804.000	6.638	51.470	58.107	-15.893	74.000
7206.000	11.005	42.040	53.045	-20.955	74.000
9608.000	14.103	36.400	50.503	-23.497	74.000
Average Detector:					
4804.000	6.638	24.190	30.827	-23.173	54.000

Note:

1. All Readings below 1GHz are Quasi-Peak, above 1GHz are performed with peak and/or average measurements as necessary.
2. Peak measurements: RBW = 1MHz, VBW = 3 MHz, Sweep: Auto.
3. Average measurements: RBW = 1MHz, VBW = 10 Hz, Sweep: Auto.
4. Measurement Level = Reading Level + Correct Factor.
5. Correct Factor = Antenna factor + Cable loss – Amplifier gain.
6. The average measurement was not performed when the peak measured data under the limit of average detection.
7. The emission levels of other frequencies are very lower than the limit and not show in test report.

Product : HP Slate Bluetooth Keyboard
 Test Item : Harmonic Radiated Emission
 Test Site : No.3 OATS
 Test Mode : Mode 1: Transmit - 1Mbps (GFSK)(2441MHz)

Frequency MHz	Correct Factor dB	Reading Level dBuV	Measurement Level dBuV/m	Margin dB	Limit dBuV/m
Horizontal					
Peak Detector:					
4882.000	3.001	50.640	53.641	-20.359	74.000
7323.000	11.846	41.630	53.477	-20.523	74.000
9764.000	12.563	37.110	49.673	-24.327	74.000
Average Detector:					
--					
Vertical					
Peak Detector:					
4882.000	5.713	53.800	59.514	-14.486	74.000
7323.000	12.727	43.040	55.768	-18.232	74.000
9764.000	13.028	37.630	50.658	-23.342	74.000
Average Detector:					
4882.000	5.713	24.050	29.764	-24.236	54.000
7323.000	12.727	21.930	34.658	-19.342	54.000

Note:

1. All Readings below 1GHz are Quasi-Peak, above 1GHz are performed with peak and/or average measurements as necessary.
2. Peak measurements: RBW = 1MHz, VBW = 3 MHz, Sweep: Auto.
3. Average measurements: RBW = 1MHz, VBW = 10 Hz, Sweep: Auto.
4. Measurement Level = Reading Level + Correct Factor.
5. Correct Factor = Antenna factor + Cable loss – Amplifier gain.
6. The average measurement was not performed when the peak measured data under the limit of average detection.
7. The emission levels of other frequencies are very lower than the limit and not show in test report.

Product : HP Slate Bluetooth Keyboard
 Test Item : Harmonic Radiated Emission
 Test Site : No.3 OATS
 Test Mode : Mode 1: Transmit - 1Mbps (GFSK)(2480MHz)

Frequency MHz	Correct Factor dB	Reading Level dBuV	Measurement Level dBuV/m	Margin dB	Limit dBuV/m
Horizontal					
Peak Detector:					
4960.000	2.760	52.260	55.020	-18.980	74.000
7440.000	12.567	41.810	54.376	-19.624	74.000
9920.000	13.456	36.410	49.866	-24.134	74.000
Average Detector:					
4960.000	2.760	35.520	38.280	-15.720	54.000
7440.000	12.567	21.460	34.026	-19.974	54.000
Vertical					
Peak Detector:					
4960.000	5.557	55.400	60.957	-13.043	74.000
7440.000	13.426	42.730	56.155	-17.845	74.000
9920.000	13.958	36.480	50.438	-23.562	74.000
Average Detector:					
4960.000	5.557	24.050	29.607	-24.393	54.000
7440.000	13.426	21.420	34.845	-19.155	54.000

Note:

1. All Readings below 1GHz are Quasi-Peak, above 1GHz are performed with peak and/or average measurements as necessary.
2. Peak measurements: RBW = 1MHz, VBW = 3 MHz, Sweep: Auto.
3. Average measurements: RBW = 1MHz, VBW = 10 Hz, Sweep: Auto.
4. Measurement Level = Reading Level + Correct Factor.
5. Correct Factor = Antenna factor + Cable loss – Amplifier gain.
6. The average measurement was not performed when the peak measured data under the limit of average detection.
7. The emission levels of other frequencies are very lower than the limit and not show in test report.

Product : HP Slate Bluetooth Keyboard
 Test Item : General Radiated Emission
 Test Site : No.3 OATS
 Test Mode : Mode 1: Transmit - 1Mbps (GFSK) (2441MHz)

Frequency MHz	Correct Factor dB	Reading Level dBuV	Measurement Level dBuV/m	Margin dB	Limit dBuV/m
Horizontal					
82.380	-11.535	46.309	34.774	-5.226	40.000
443.220	-2.738	40.742	38.004	-7.996	46.000
577.080	3.169	34.200	37.369	-8.631	46.000
743.920	3.326	34.151	37.477	-8.523	46.000
912.700	6.132	30.920	37.052	-8.948	46.000
1000.000	9.119	34.051	43.170	-10.830	54.000
Vertical					
76.560	-5.258	38.110	32.852	-7.148	40.000
167.740	-8.239	43.855	35.616	-7.884	43.500
408.300	-6.606	43.510	36.904	-9.096	46.000
664.380	-1.918	38.458	36.540	-9.460	46.000
749.740	2.510	34.954	37.464	-8.536	46.000
996.120	4.019	38.781	42.800	-11.200	54.000

Note:

1. All Readings below 1GHz are Quasi-Peak, above 1GHz are performed with peak and/or average measurements as necessary.
2. Peak measurements: RBW = 1MHz, VBW = 3 MHz, Sweep: Auto.
3. Average measurements: RBW = 1MHz, VBW = 10 Hz, Sweep: Auto.
4. Measurement Level = Reading Level + Correct Factor.
5. Correct Factor = Antenna factor + Cable loss – Amplifier gain.
6. The average measurement was not performed when the peak measured data under the limit of average detection.
7. The emission levels of other frequencies are very lower than the limit and not show in test report.

5. RF Antenna Conducted Test

5.1. Test Equipment

Equipment	Manufacturer	Model No./Serial No.	Last Cal.
Spectrum Analyzer	R&S	FSP40 / 100170	Jun, 2011
Spectrum Analyzer	Agilent	E4407B / US39440758	Jun, 2011
X Spectrum Analyzer	Agilent	N9010A / MY48030495	Apr., 2011

Note: 1. All equipments are calibrated every one year.
 2. The test instruments Marked “X” are used to measure the final test results.

5.2. Test Setup

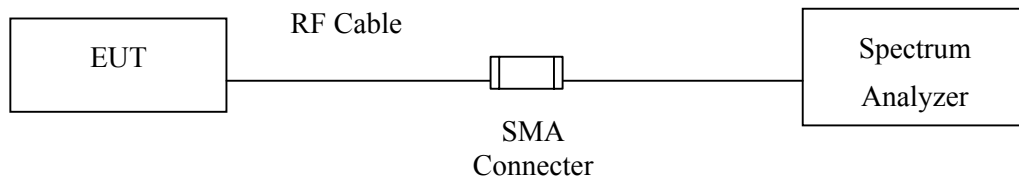

5.3. Limits

According to FCC Section 15.247(d). In any 100 kHz bandwidth outside the frequency band in which the spread spectrum or digitally modulated intentional radiator is operating, the radio frequency power that is produced by the intentional radiator shall be at least 20 dB below that in the 100 kHz bandwidth within the band that contains the highest level of the desired power, based on either an RF conducted or measurement, provided the transmitter demonstrates compliance with the peak conducted power limits. If the transmitter complies with the conducted power limits based on the use of RMS averaging over a time interval, the attenuation required under this paragraph shall be 30 dB instead of 20 dB.

5.4. Test Procedure

The EUT was setup to ANSI C63.4, 2009; tested to FHSS test procedure of FCC Public Notice DA 00-705 for compliance to FCC 47CFR 15.247 requirements.

5.5. Uncertainty

± 150Hz

5.6. Test Result of RF Antenna Conducted Test

Product : HP Slate Bluetooth Keyboard
 Test Item : RF Antenna Conducted Test
 Test Site : No.3 OATS
 Test Mode : Mode 1: Transmit - 1Mbps (GFSK)

Figure Channel 00: 30MHz-25GHz



Product : HP Slate Bluetooth Keyboard
 Test Item : RF Antenna Conducted Test
 Test Site : No.3 OATS
 Test Mode : Mode 1: Transmit - 1Mbps (GFSK)

Figure Channel 39: 30MHz-25GHz

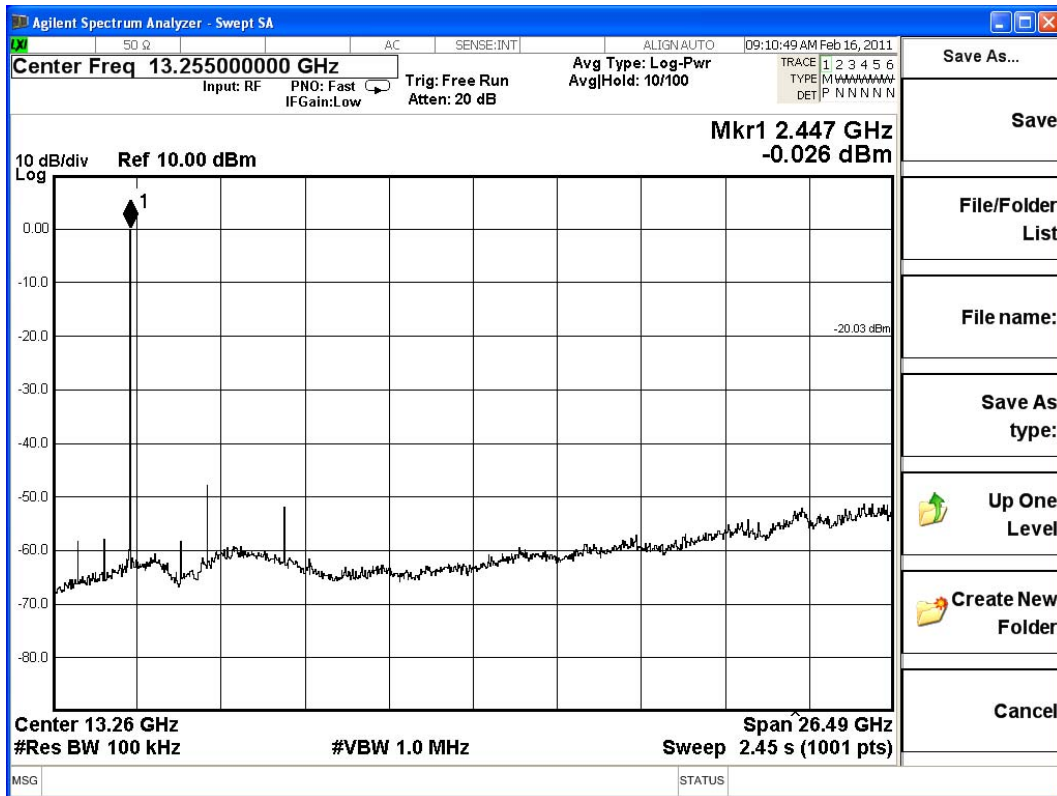

Product : HP Slate Bluetooth Keyboard
 Test Item : RF Antenna Conducted Test
 Test Site : No.3 OATS
 Test Mode : Mode 1: Transmit - 1Mbps (GFSK)

Figure Channel 78: 30MHz-25GHz

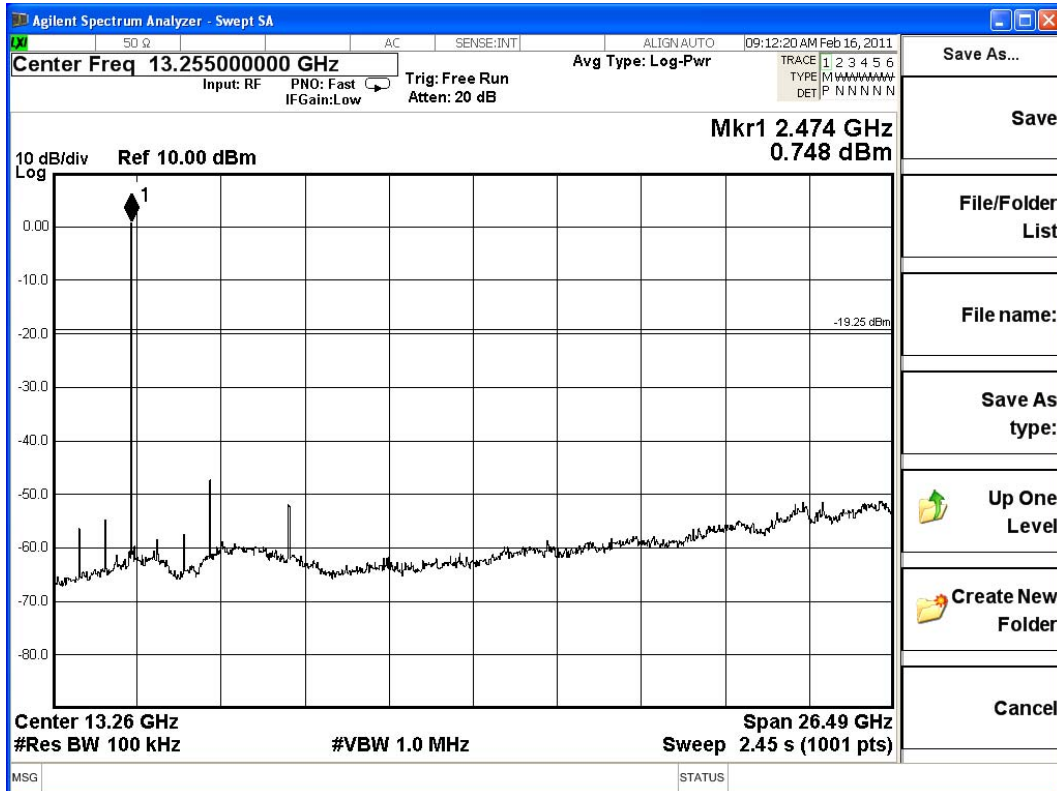

6. Band Edge

6.1. Test Equipment

RF Conducted Measurement

The following test equipments are used during the band edge tests:

	Equipment	Manufacturer	Model No./Serial No.	Last Cal.
	Spectrum Analyzer	R&S	FSP40 / 100170	Jun, 2011
	Spectrum Analyzer	Agilent	E4407B / US39440758	Jun, 2011
X	Spectrum Analyzer	Agilent	N9010A / MY48030495	Apr., 2011

RF Radiated Measurement:

The following test equipments are used during the band edge tests:

Test Site		Equipment	Manufacturer	Model No./Serial No.	Last Cal.
☒ Site # 3		Bilog Antenna	Schaffner Chase	CBL6112B/2673	Sep., 2011
	X	Horn Antenna	Schwarzbeck	BBHA9120D/D305	Sep., 2011
		Horn Antenna	Schwarzbeck	BBHA9170/208	Jul., 2011
	X	Pre-Amplifier	Agilent	8447D/2944A09549	Sep., 2011
	X	Spectrum Analyzer	Agilent	E4407B / US39440758	May, 2011
		Test Receiver	R & S	ESCS 30/ 825442/018	Sep., 2011
	X	Coaxial Cable	Quietek	QTK-CABLE/ CAB5	Feb., 2011
	X	Controller	Quietek	QTK-CONTROLLER/ CTRL3	N/A
	X	Coaxial Switch	Anritsu	MP59B/6200265729	N/A

- Note:
1. All equipments are calibrated every one year.
 2. The test instruments marked by "X" are used to measure the final test results.

6.2. Test Setup

RF Conducted Measurement

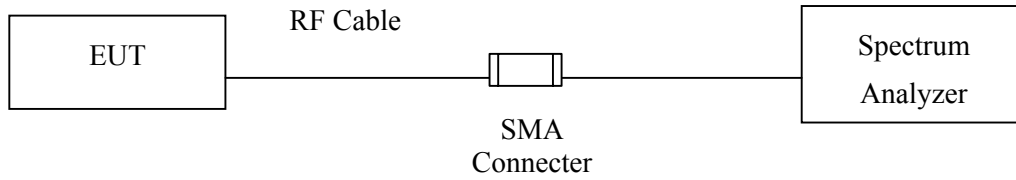

RF Radiated Measurement:

Above 1GHz

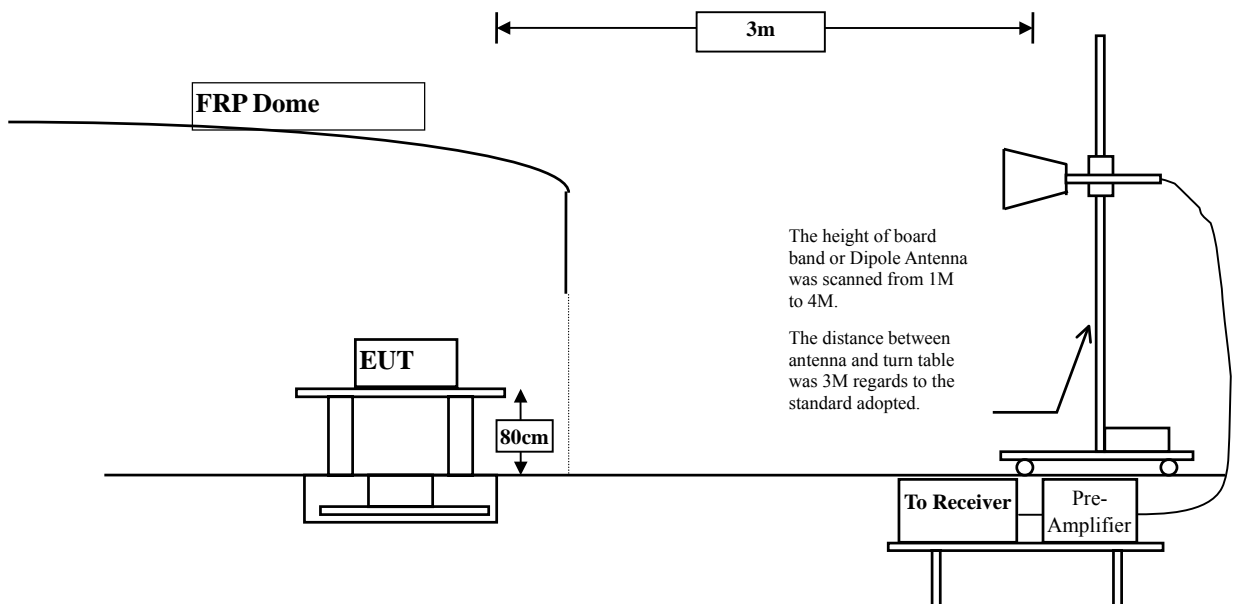

6.3. Limit

In any 100 kHz bandwidth outside the frequency band in which the spread spectrum intentional radiator is operating, the radio frequency power that is produced by the intentional radiator shall be at least 20 dB below that in the 100 kHz bandwidth within the band that contains the highest level of the desired power, based on either an RF conducted or a radiated measurement. Attenuation below the general limits specified in Section 15.209(a) is not required. In addition, radiated emissions which fall in the restricted bands, as defined in Section 15.205(a), must also comply with the radiated emission limits specified in Section 15.209(a) (see Section 15.205(c)).

6.4. Test Procedure

The EUT and its simulators are placed on a turn table which is 0.8 meter above ground. The turn table can rotate 360 degrees to determine the position of the maximum emission level. The EUT was positioned such that the distance from antenna to the EUT was 3 meters.

The antenna can move up and down between 1 meter and 4 meters to find out the maximum emission level.

Both horizontal and vertical polarization of the antenna are set on measurement. In order to find the maximum emission, all of the interface cables must be manipulated according to ANSI C63.4:2009 on radiated measurement.

The bandwidth below 1GHz setting on the field strength meter is 120 kHz, above 1GHz are 1 MHz. The EUT was setup to ANSI C63.4, 2009; tested to FHSS test procedure of FCC Public Notice DA 00-705 for compliance to FCC 47CFR 15.247 requirements.

6.5. Uncertainty

± 3.9 dB above 1GHz

± 3.8 dB below 1GHz

6.6. Test Result of Band Edge

Product : HP Slate Bluetooth Keyboard
 Test Item : Band Edge
 Test Site : No.3 OATS
 Test Mode : Mode 1: Transmit - 1Mbps (GFSK)

Fundamental Filed Strength

Antenna Pole	Frequency [MHz]	Correction Factor [dB/m]	Reading Level [dBuV]	Emission Level [dBuV/m]	Detector
Horizontal	2402	31.573	60.48	92.054	Peak
Horizontal	2402	31.573	59.73	91.304	Average
Vertical	2402	30.917	59.65	90.567	Peak
Vertical	2402	30.917	59.02	89.937	Average

Note: 1:Spectrum Analyzer setting:

Peak detector: RBW=1MHz, VBW=1MHz

Average detector: RBW=1MHz, VBW=10Hz

Band Edge Test Data

Antenna Pole	Test Frequency (MHz)	Fundamental (dBuV/m)	Δ (dB)	Band Edge Field Strength (dBuV/m)	Detector
Horizontal	2354	92.054	54.756	37.298	Peak
Horizontal	2354	91.304	64.347	26.957	Average
Vertical	2354	90.567	54.756	35.811	Peak
Vertical	2354	89.937	64.347	25.59	Average

Note:

The Band Edge Field Strength was calculated using the Fundamental and Conducted Band Edge measurements per the Marker-Delta Method with the following formula:

Band Edge field Strength = F - Δ

F = Fundamental field Strength (Peak or Average)

Δ = Conducted Band Edge Delta (Peak or Average)

Peak Detector of conducted Band Edge Delta

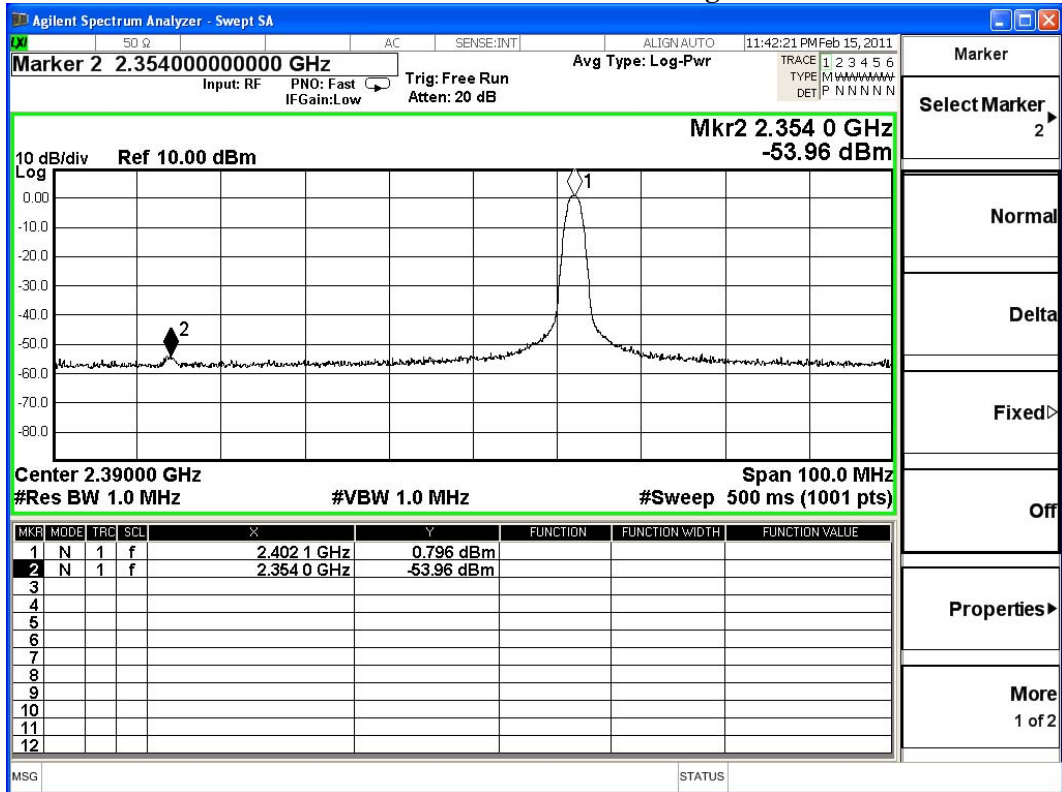

Average Detector of conducted Band Edge Delta

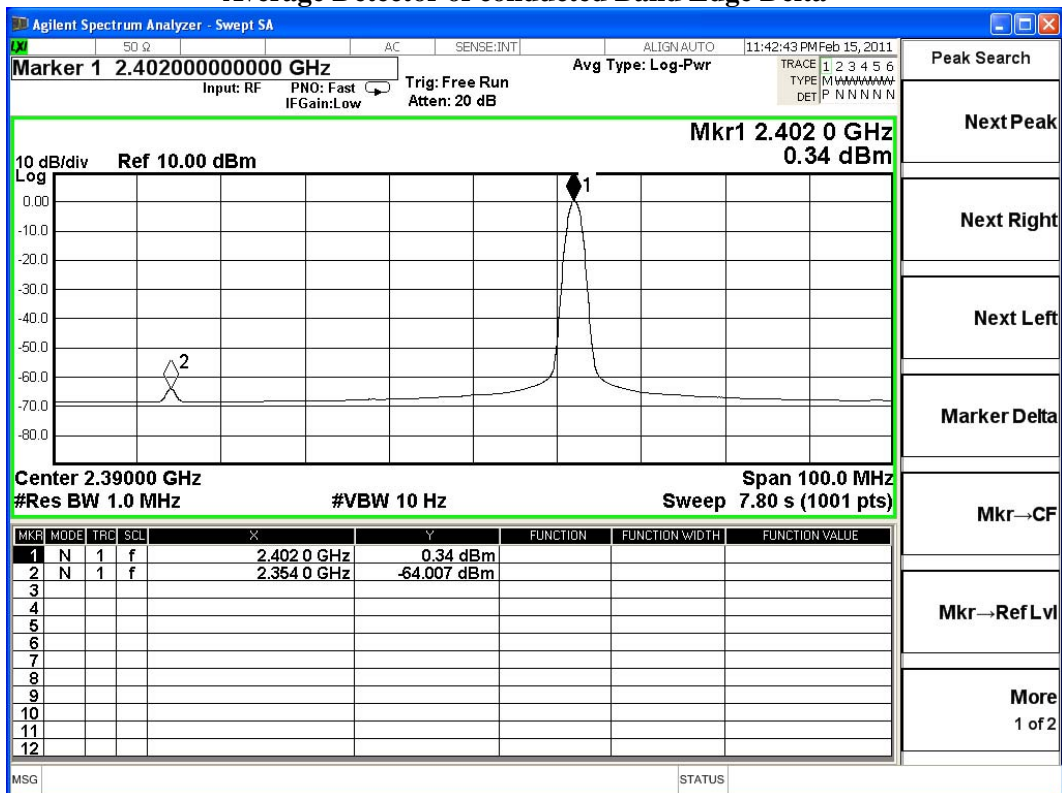

Product : HP Slate Bluetooth Keyboard
 Test Item : Band Edge
 Test Site : No.3 OATS
 Test Mode : Mode 1: Transmit - 1Mbps (GFSK)

Fundamental Filed Strength

Antenna Pole	Frequency [MHz]	Correction Factor [dB/m]	Reading Level [dBuV]	Emission Level [dB(uV/m)]	Detector
Horizontal	2480	32.155	59.09	91.246	Peak
Horizontal	2480	32.155	58.24	90.396	Average
Vertical	2480	31.412	57.94	89.352	Peak
Vertical	2480	31.412	56.73	88.142	Average

Note: 1:Spectrum Analyzer setting:

Peak detector: RBW=1MHz, VBW=1MHz

Average detector: RBW=1MHz, VBW=10Hz

Band Edge Test Data

Antenna Pole	Test Frequency (MHz)	Fundamental (dBuV/m)	Δ (dB)	Band Edge Field Strength (dBuV/m)	Detector
Horizontal	2483.5	91.246	48.173	43.073	Peak
Horizontal	2483.5	90.396	61.65	28.746	Average
Vertical	2483.5	89.352	48.173	41.179	Peak
Vertical	2483.5	88.142	61.65	26.492	Average

Note:

The Band Edge Field Strength was calculated using the Fundamental and Conducted Band Edge measurements per the Marker-Delta Method with the following formula:

Band Edge field Strength = F - Δ

F = Fundamental field Strength (Peak or Average)

Δ = Conducted Band Edge Delta (Peak or Average)

Peak Detector of conducted Band Edge Delta

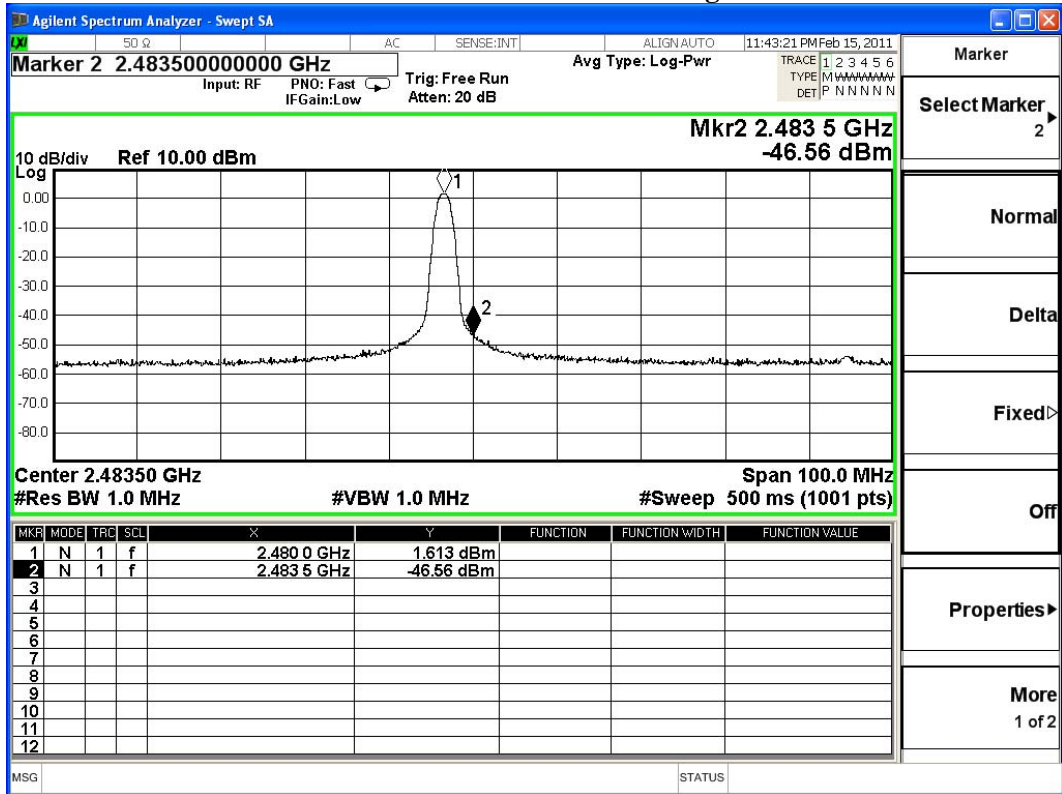

Average Detector of conducted Band Edge Delta

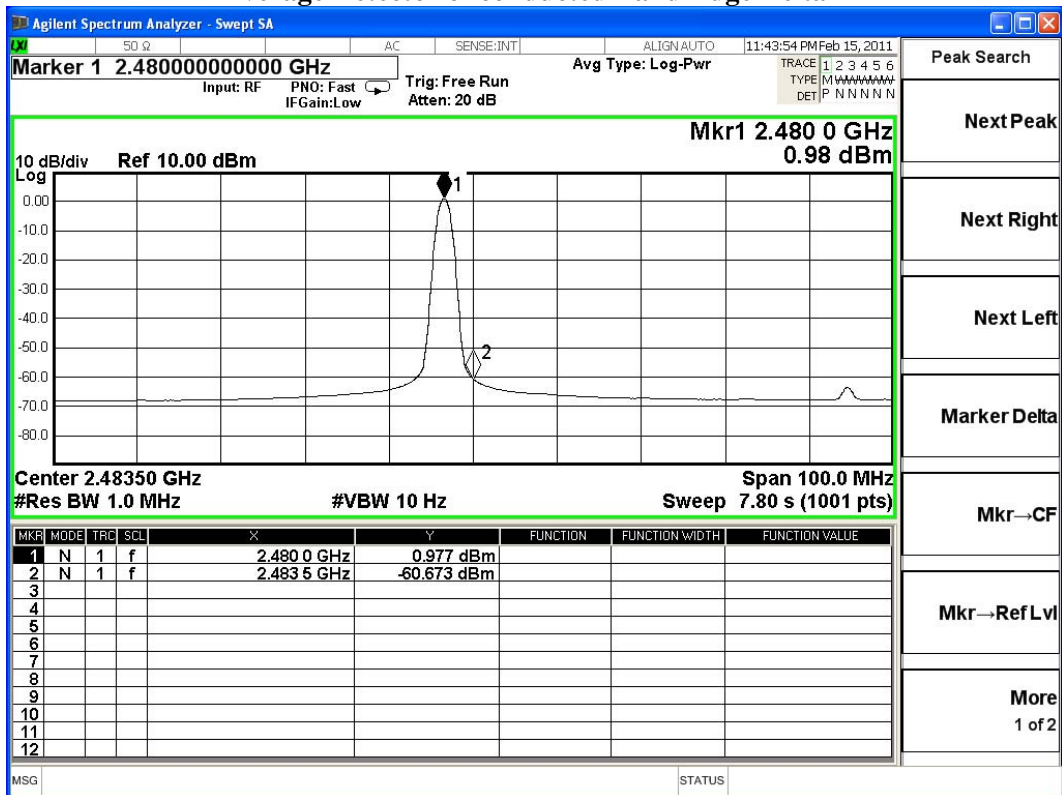

7. Channel Number

7.1. Test Equipment

	Equipment	Manufacturer	Model No./Serial No.	Last Cal.
	Spectrum Analyzer	R&S	FSP40 / 100170	Jun, 2011
	Spectrum Analyzer	Agilent	E4407B / US39440758	Jun, 2011
X	Spectrum Analyzer	Agilent	N9010A / MY48030495	Apr., 2011

Note: 1. All equipments are calibrated every one year.
 2. The test instruments marked by “X” are used to measure the final test results.

7.2. Test Setup

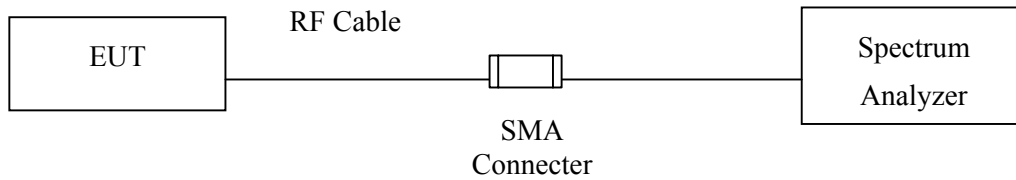

7.3. Limit

Frequency hopping systems operating in the 2400-2483.5 MHz bands shall use at least 75 hopping frequencies.

7.4. Test Procedure

The EUT was setup to ANSI C63.4, 2009; tested to FHSS test procedure of FCC Public Notice DA 00-705 for compliance to FCC 47CFR 15.247 requirements.

7.5. Uncertainty

N/A

7.6. Test Result of Channel Number

Product : HP Slate Bluetooth Keyboard
 Test Item : Channel Number
 Test Site : No.3 OATS
 Test Mode : Mode 1: Transmit - 1Mbps (GFSK)

Frequency Range (MHz)	Measurement (Hopping Channel)	Required Limit (Hopping Channel)	Result
2402 ~ 2480	79	>75	Pass

2402-2441MHz

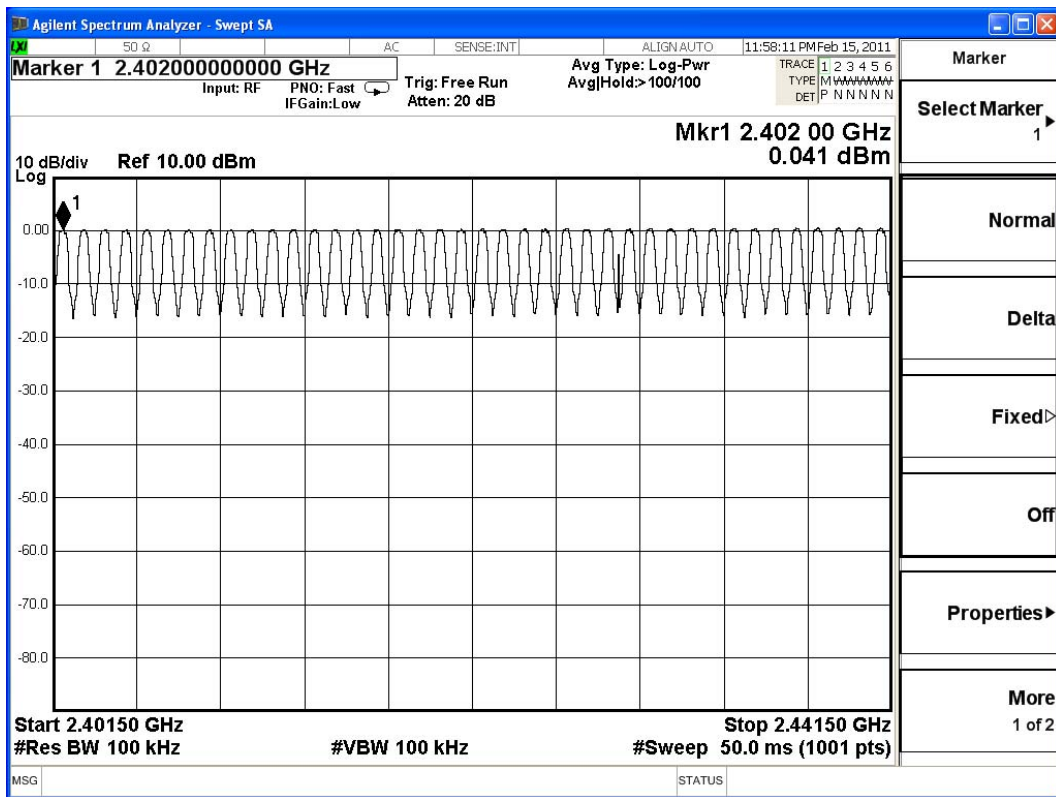

2442-2480MHz

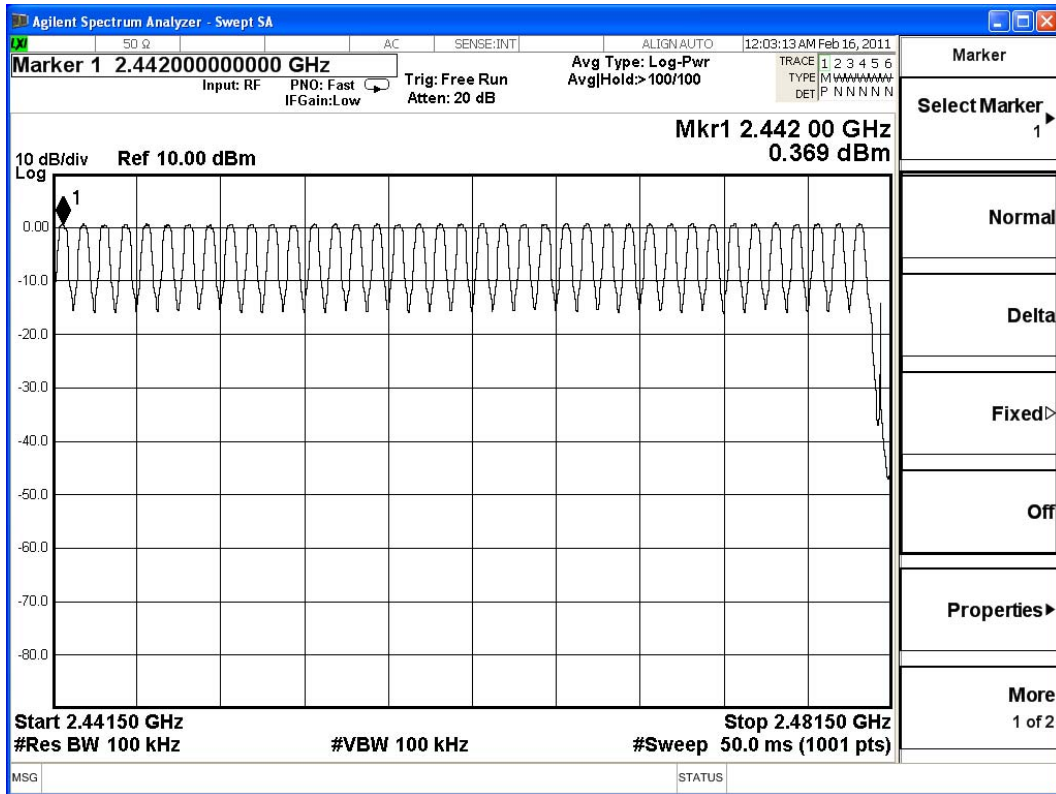

8. Channel Separation

8.1. Test Equipment

	Equipment	Manufacturer	Model No./Serial No.	Last Cal.
	Spectrum Analyzer	R&S	FSP40 / 100170	Jun, 2011
	Spectrum Analyzer	Agilent	E4407B / US39440758	Jun, 2011
X	Spectrum Analyzer	Agilent	N9010A / MY48030495	Apr., 2011

Note: 1. All equipments are calibrated every one year.
 2. The test instruments mark by “X” are used to measure the final test results.

8.2. Test Setup

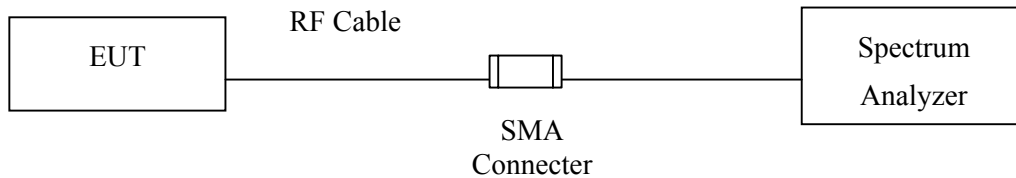

8.3. Limit

Frequency hopping systems shall have hopping channel carrier frequencies separated by a minimum of 25 kHz or the 20 dB bandwidth of the hopping channel, whichever is greater.

8.4. Test Procedure

The EUT was setup to ANSI C63.4, 2009; tested to FHSS test procedure of FCC Public Notice DA 00-705 for compliance to FCC 47CFR 15.247 requirements.

8.5. Uncertainty

± 150Hz

8.6. Test Result of Channel Separation

Product : HP Slate Bluetooth Keyboard
 Test Item : Channel Separation
 Test Site : No.3 OATS
 Test Mode : Mode 1: Transmit - 1Mbps (GFSK)

Channel No.	Frequency (MHz)	Measurement Level (kHz)	Limit (kHz)	Limit of (2/3)*20dB Bandwidth (kHz)	Result
00	2402	1000	>25 kHz	753.3	Pass
39	2441	1000	>25 kHz	753.3	Pass
78	2480	1000	>25 kHz	746.7	Pass

NOTE: The 20dB Bandwidth is refer to section 10.

Channel 00 2402MHz

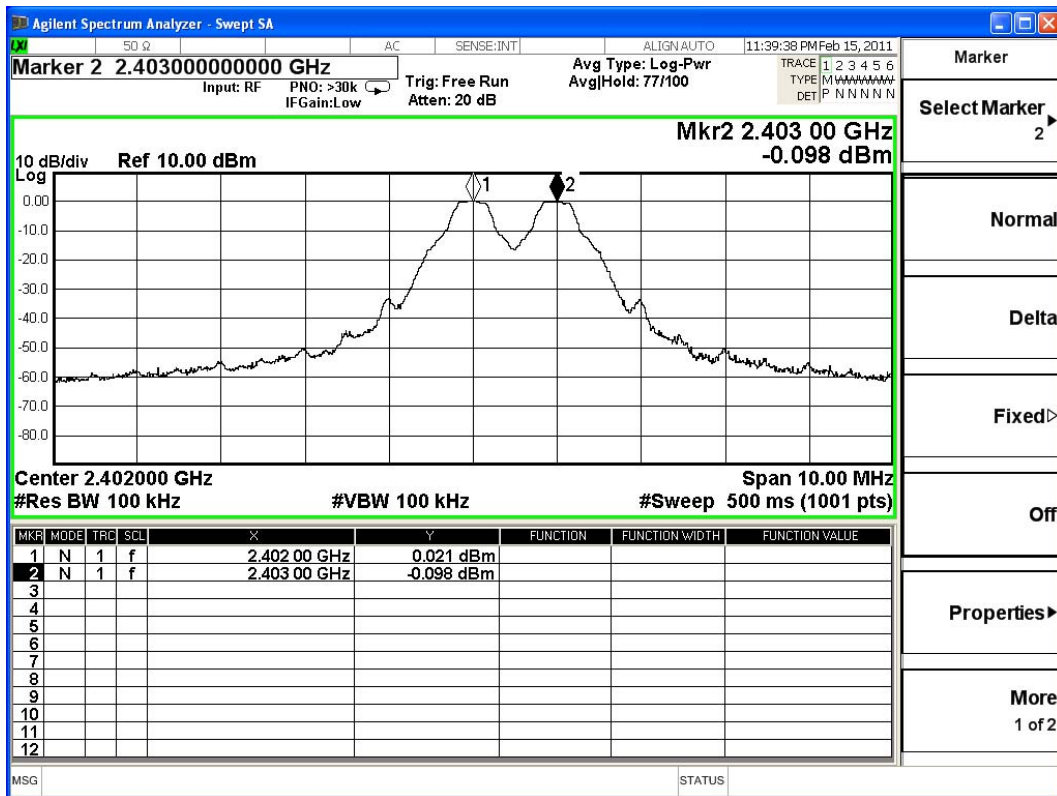

Channel 39 2441MHz

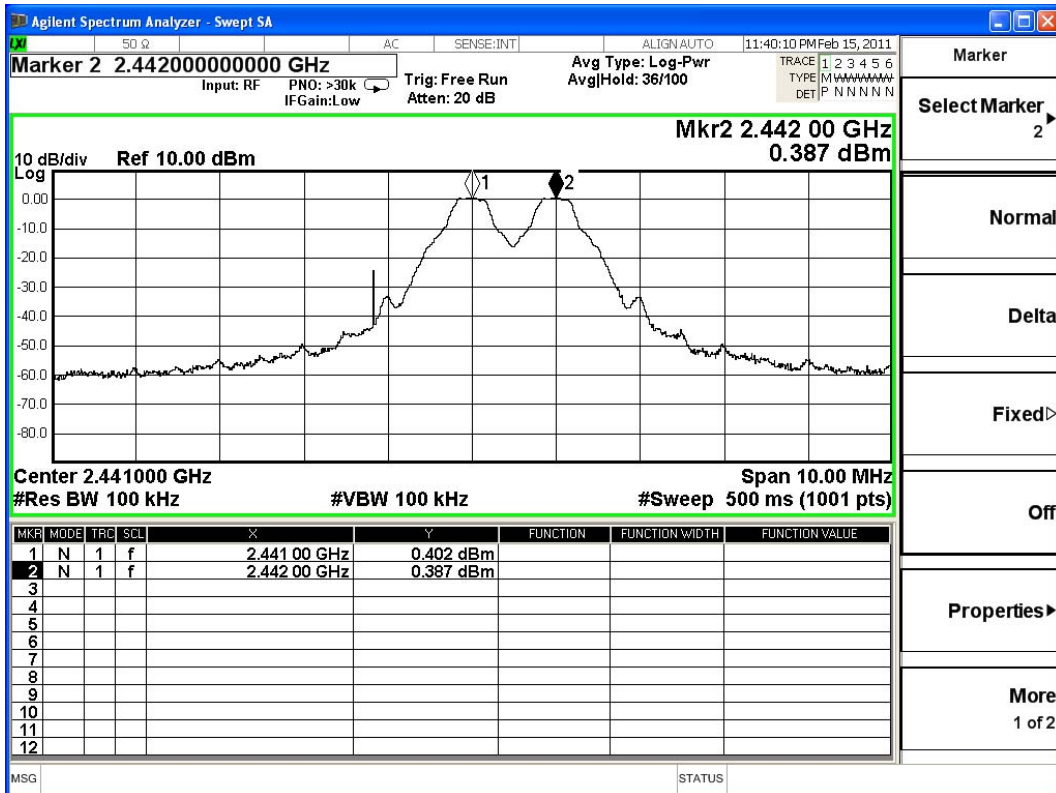

Channel 78 2480 MHz

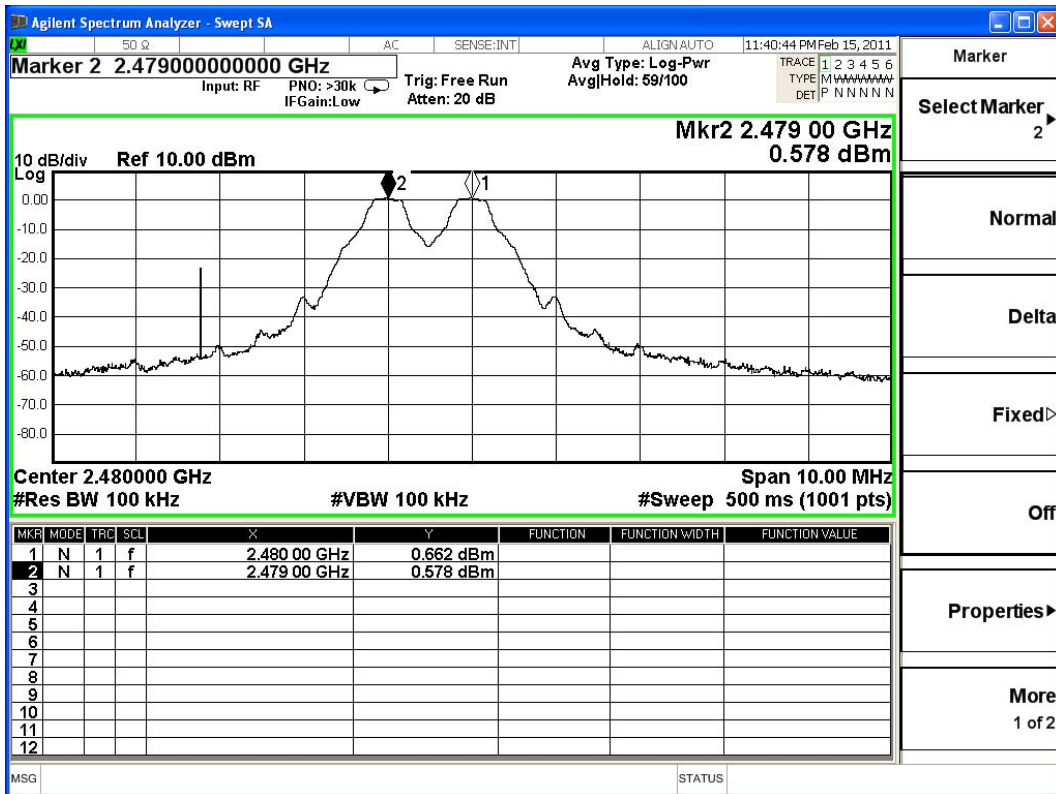

9. Dwell Time

9.1. Test Equipment

	Equipment	Manufacturer	Model No./Serial No.	Last Cal.
	Spectrum Analyzer	R&S	FSP40 / 100170	Jun, 2011
	Spectrum Analyzer	Agilent	E4407B / US39440758	Jun, 2011
X	Spectrum Analyzer	Agilent	N9010A / MY48030495	Apr., 2011

Note: 1. All equipments are calibrated every one year.
 2. The test instruments marked by “X” are used to measure the final test results.

9.2. Test Setup

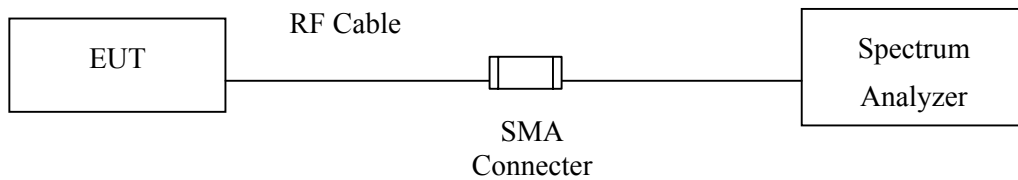

9.3. Limit

The dwell time shall be the average time of occupancy on any frequency shall not be greater than 0.4 seconds within a 30 second period.

9.4. Test Procedure

The EUT was setup to ANSI C63.4, 2009; tested to FHSS test procedure of FCC Public Notice DA 00-705 for compliance to FCC 47CFR 15.247 requirements.

9.5. Uncertainty

± 25msec

9.6. Test Result of Dwell Time

Product : HP Slate Bluetooth Keyboard
 Test Item : Dwell Time
 Test Site : No.3 OATS
 Test Mode : Mode 1: Transmit - 1Mbps (GFSK) (Channel 00,39,78 –DH5)

Frequency (MHz)	Time slot length (ms)	Hopping of Number	Sweep time (ms)	Duty cycle	Dwell Time (Sec)	Limit (Sec)	Result
2402	3.050	14	50	0.85	0.342	0.4	Pass
2441	3.050	14	50	0.85	0.342	0.4	Pass
2480	3.040	14	50	0.85	0.340	0.4	Pass

Duty cycle = ((Time slot length(ms)*Hopping of Number) / Sweep time (ms))

Dwell time = (Duty cycle / 79) * (79*0.4)

CH 00 Time Interval between hops

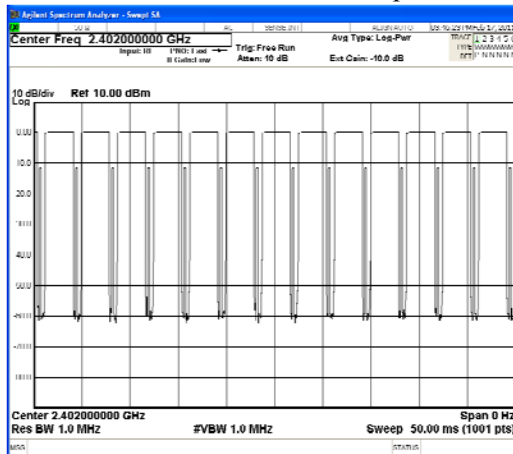

CH 00 Transmission Time

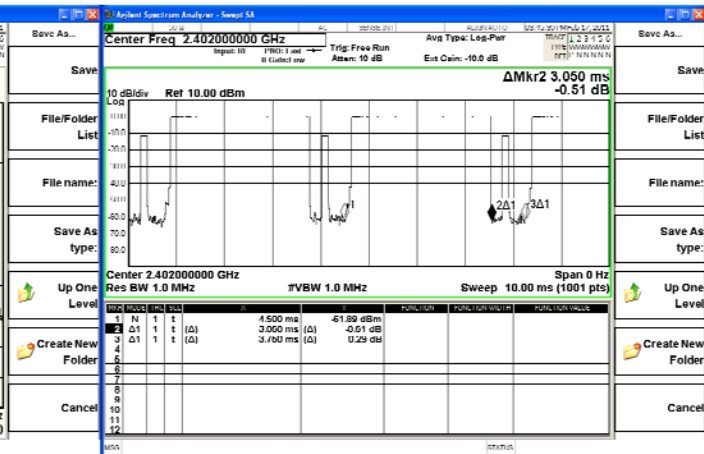

CH39 Time Interval between hops

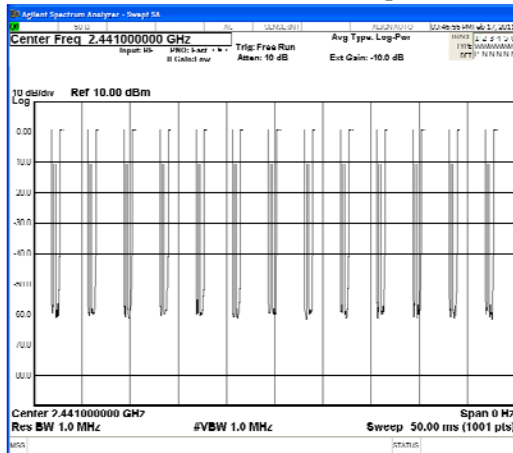

CH 39 Transmission Time

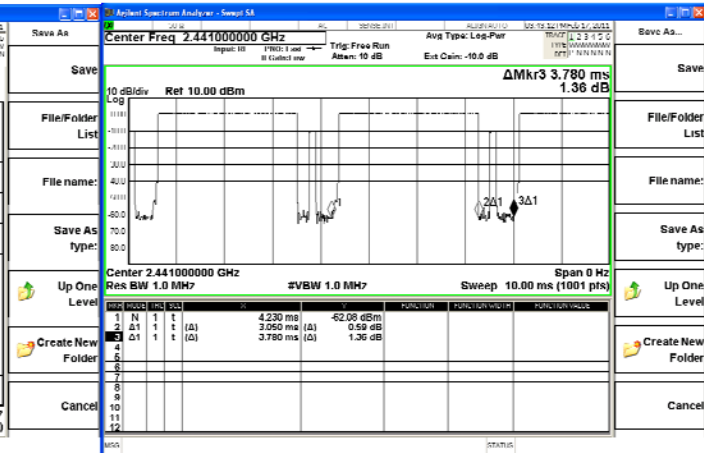

CH 78 Time Interval between hops

CH 78 Transmission Time

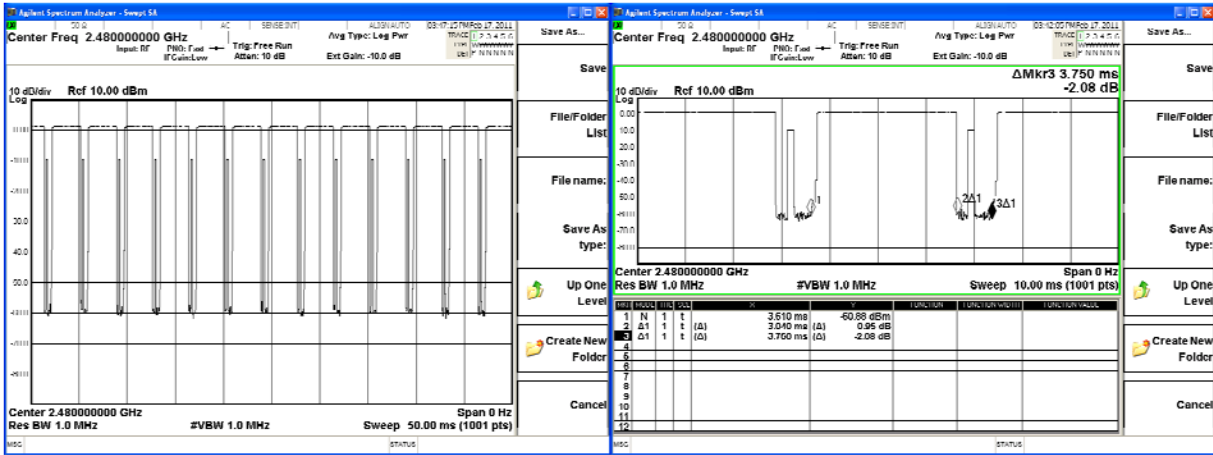

Note:

The dwell times of the packet type of DH1, DH3, and DH5 are tested. Only the worst case is shown on the report.

10. Occupied Bandwidth

10.1. Test Equipment

	Equipment	Manufacturer	Model No./Serial No.	Last Cal.
	Spectrum Analyzer	R&S	FSP40 / 100170	Jun, 2011
	Spectrum Analyzer	Agilent	E4407B / US39440758	Jun, 2011
X	Spectrum Analyzer	Agilent	N9010A / MY48030495	Apr., 2011

- Note: 1. All equipments are calibrated every one year.
 2. The test instruments marked by "X" are used to measure the final test results.

10.2. Test Setup

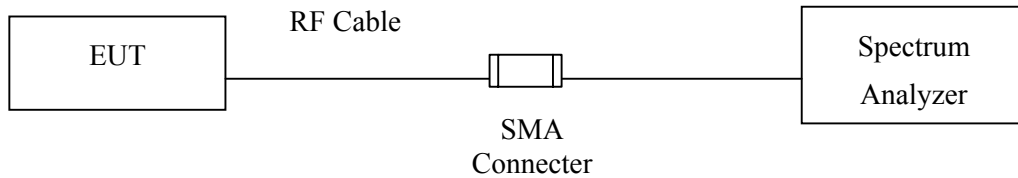

10.3. Limits

N/A

10.4. Test Procedure

The EUT was setup to ANSI C63.4, 2009; tested to FHSS test procedure of FCC Public Notice DA 00-705 for compliance to FCC 47CFR 15.247 requirements.

10.5. Uncertainty

± 150Hz

10.6. Test Result of Occupied Bandwidth

Product : HP Slate Bluetooth Keyboard
 Test Item : Occupied Bandwidth Data
 Test Site : No.3 OATS
 Test Mode : Mode 1: Transmit - 1Mbps (GFSK)(2402MHz)

Channel No.	Frequency (MHz)	Measurement Level (kHz)	Required Limit (kHz)	Result
00	2402	1130	--	NA

Figure Channel 00:

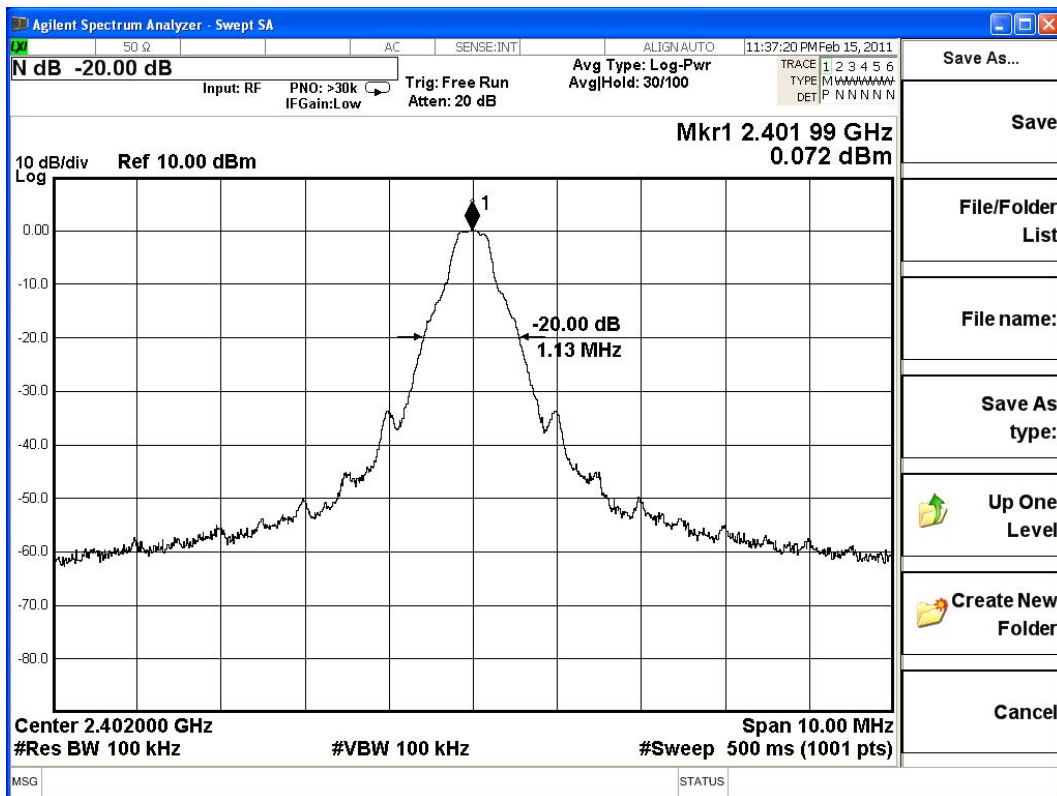

Product : HP Slate Bluetooth Keyboard
 Test Item : Occupied Bandwidth Data
 Test Site : No.3 OATS
 Test Mode : Mode 1: Transmit - 1Mbps (GFSK)(2441MHz)

Channel No.	Frequency (MHz)	Measurement Level (kHz)	Required Limit (kHz)	Result
39	2441	1130	--	NA

Figure Channel 39:

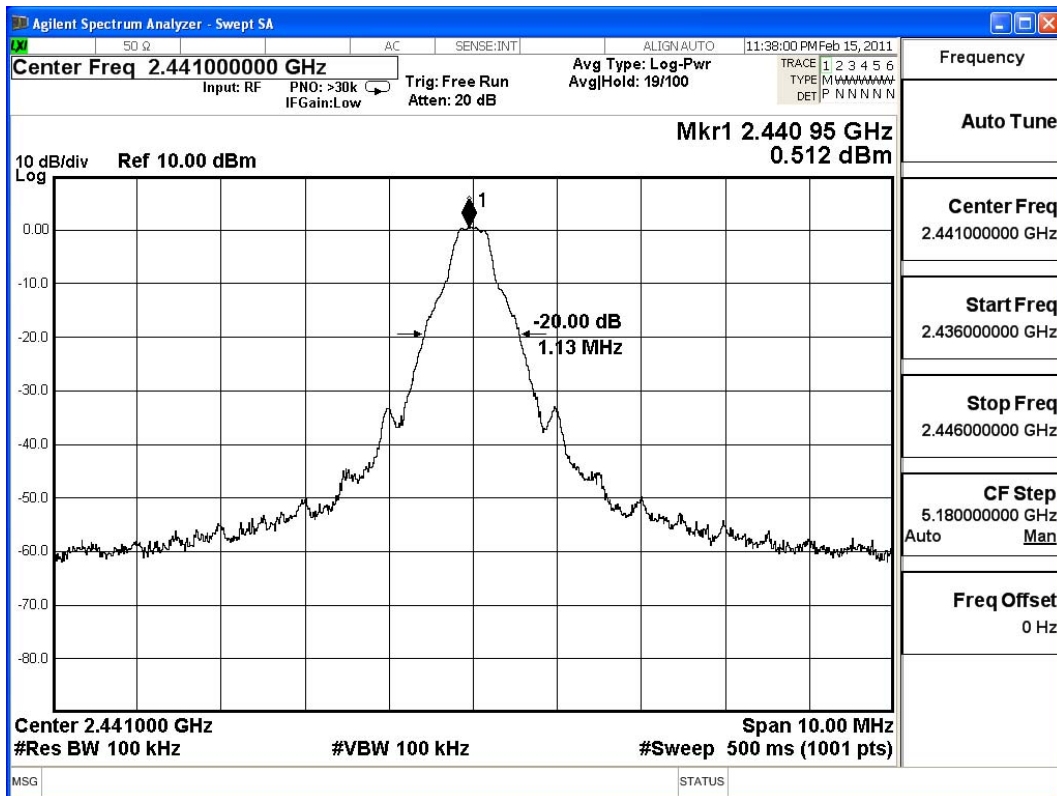

Product : HP Slate Bluetooth Keyboard
 Test Item : Occupied Bandwidth Data
 Test Site : No.3 OATS
 Test Mode : Mode 1: Transmit - 1Mbps (GFSK)(2480MHz)

Channel No.	Frequency (MHz)	Measurement Level (kHz)	Required Limit (kHz)	Result
78	2480	1120	--	NA

Figure Channel 78:

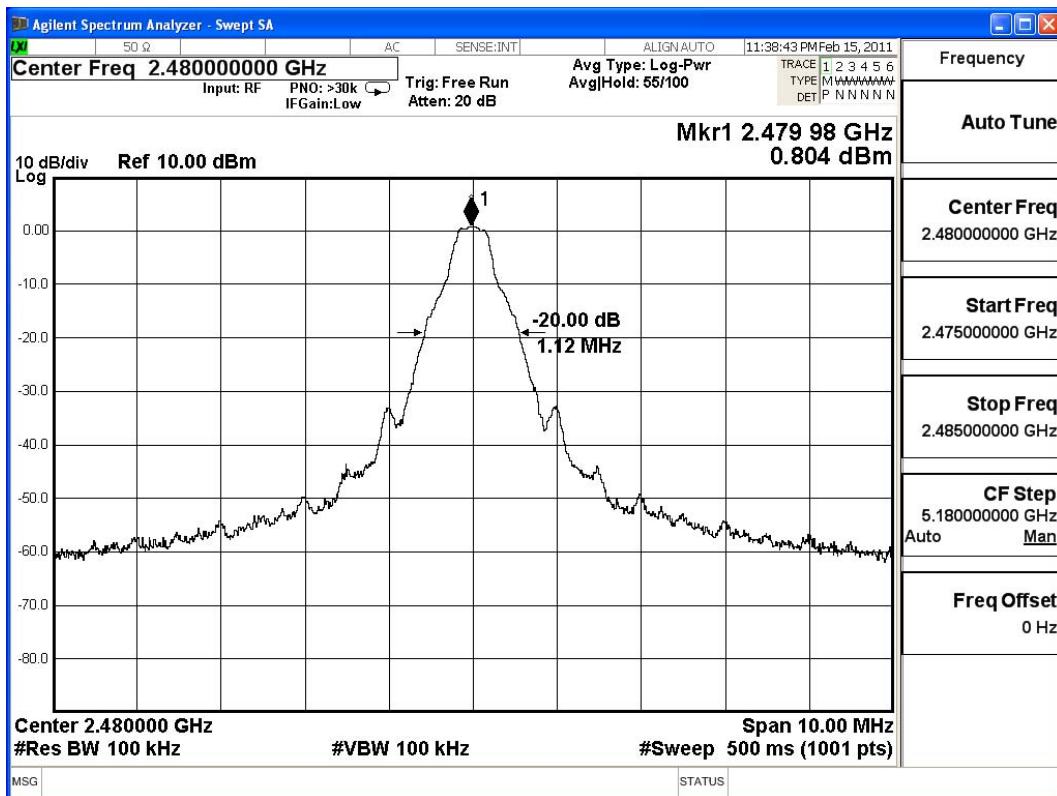

11. EMI Reduction Method During Compliance Testing

No modification was made during testing.