FCC Test Report

Report No: WD-RF-R-240154-A0

Product Name : Network Camera
Model Name : WPR210-FTEL
FCC ID : O5PWPR210
Applicant : VIVOTEK INC.
Received Date : Apr. 29, 2024
Tested Date : May 15, 2024 ~ Sep. 23, 2024
Applicable Standard : 47 CFR FCC Part 15, Subpart C (Section 15.247)
KDB 558074 D01 DTS Meas. Guidance v05
ANSI C63.10 : 2013



Wendell Industrial Co., Ltd
Wendell EMC & RF Laboratory

Caution:

This report sets forth our findings solely with respect to the test samples identified herein. The results set forth in this report are not indicative or representative of the quality or characteristics of the lot from which a test sample was taken or any similar or identical product unless specifically and expressly noted.

The test results shown in the test report are traceable to the national/international standard through the calibration report of the equipment.

Please note that the measurement uncertainty are provided for informational purpose only and are not used in determining the Pass/Fail results.

This report must not be used to claim product endorsement by TAF or any agency of the government.

The test report shall not be reproduced without the written approval of Wendell Industrial Co., Ltd..

Test Report

Issued Date: September 24, 2024

Project No.: 24Q042601

Product Name	Network Camera
Trade Name	VIVOTEK
Model Name	WPR210-FTEL
FCC ID	O5PWPR210
Applicant	VIVOTEK INC.
Manufacturer	VIVOTEK INC.
EUT Rated Voltage	Adapter : AC 100 - 240V ~ 50 / 60Hz
EUT Test Voltage	AC 120V / 60Hz
EUT Supports Radios Application	WLAN 802.11b/g WLAN 802.11n (HT20)
Applicable Standard	47 CFR FCC Part 15, Subpart C (Section 15.247) KDB 558074 D01 DTS Meas. Guidance v05 ANSI C63.10 : 2013
Output Power	24.81 dBm
Test Result	Complied

Documented :



(Specialist / Emma Lu)

Technical Engineer :



(Section Manager / Jack Chang)

Approved :

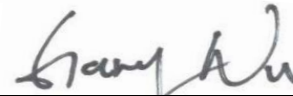

(Project Manager / Gary Wu)

Table of Contents

Document Revision History	5
Summary of Test Result	6
1 Generation Information	7
1.1 Applicant	7
1.2 Manufacturer	7
1.3 Description of Equipment under Test	7
1.4 Test Mode Applicability And Tested Channel Detail	10
1.5 Configuration of Tested System	12
1.6 EUT Exercise Software	13
1.7 Tested System Details	13
1.8 Test Facility	14
1.9 Measurement Uncertainty	15
1.10 List of Test Equipment	16
2 Test Result	20
2.1 Antenna Requirement	20
2.1.1 Applicable Standard	20
2.1.2 Antenna Connected Construction	20
2.1.3 Antenna Gain	20
2.2 Peak Output Power Measurement	21
2.2.1 Limit	21
2.2.2 Test Setup	21
2.2.3 Test Procedure	21
2.2.4 Test Result	22
2.3 6dB Bandwidth Measurement	23
2.3.1 Limit	23
2.3.2 Test Setup	23
2.3.3 Test Procedure	23
2.3.4 Test Result	24
2.4 Power Spectral Density Measurement	27
2.4.1 Limit	27
2.4.2 Test Setup	27
2.4.3 Test Procedure	27
2.4.4 Test Result	28
2.5 Conducted Band Edges and Spurious Emission Measurement	31
2.5.1 Limit	31
2.5.2 Test Setup	31
2.5.3 Test Procedure	31
2.5.4 Test Result	32
2.6 Radiated Band Edges and Spurious Emission Measurement	41
2.6.1 Limit	41
2.6.2 Test Setup	42
2.6.3 Test Procedure	43
2.6.4 Duty Cycle	45
2.6.5 Test Result of Radiated Band Edge Measurement	45
2.6.6 Test Result of Radiated Spurious Emission Measurement	58
2.7 AC Conducted Emissions Measurement	79
2.7.1 Limit	79

2.7.2 Test Setup..... 79
2.7.3 Test Procedure..... 80
2.7.4 Test Result 81

Attachment 1: EUT Test Photographs

Attachment 2: EUT Detailed Photographs

Document Revision History

Report No.	Issue date	Description
WD-RF-R-240154-A0	September 24, 2024	Initial report

Summary of Test Result

Ref. Std. Clause	Test Items	Result
15.203 15.247(C)	Antenna Requirement	Pass
15.247(b)	Peak Output Power	Pass
15.247(a)(2)	6dB Bandwidth	Pass
15.247(e)	Power Spectral Density	Pass
15.247(d)	Conducted Band Edges and Conducted Spurious Emission	Pass
15.247(d)	Radiated Band Edges and Radiated Spurious Emission	Pass
15.207	AC Conducted Emission	Pass

1 Generation Information

1.1 Applicant

VIVOTEK INC.
6F, No.192, Lien-Cheng Rd., Chung-Ho , New Taipei City, 235, Taiwan, R.O.C.

1.2 Manufacturer

VIVOTEK INC.
5F, No.168, Lien-Cheng Rd., Chung-Ho , New Taipei City, 235, Taiwan, R.O.C.

1.3 Description of Equipment under Test

Product Name	Network Camera
Model No.	WPR210-FTEL
FCC ID	O5PWPR210
Frequency Range	802.11b/g/n-20MHz: 2412~2462MHz
Number of Channels	802.11b/g/n-20MHz: 11
Data Rate	802.11b: 1-11Mbps, 802.11g: 6-54Mbps, 802.11n: up to 72.2Mbps
Channel separation	802.11b/g/n: 5 MHz
Type of Modulation	802.11b:DSSS (DBPSK, DQPSK, CCK) 802.11g/n:OFDM (BPSK, QPSK, 16QAM, 64QAM)
Antenna Information	Refer to the table “Antenna List”
EUT Supports Radios Application	WLAN 802.11b/g WLAN 802.11n (HT20)
EUT Rated Voltage	Adapter : AC 100 - 240V ~ 50 / 60Hz
EUT Test Voltage	AC 120V / 60Hz

The EUT uses following adapter.

Trade Name	KEYU
Model No.	KA12C-0502000US
Input Power	AC 100 – 240V ~ 50 / 60Hz 0.35A Max
Output Power	DC 5V/2000mA
Power Line	N/A

Antenna List

No.	Manufacturer	Model No.	Antenna Type	Peak Gain
1	Wanshih	3411EM05002A	FPCB Antenna	3.47 dBi for 2.4GHz

Remark: The antenna of EUT is conforming to FCC 15.203

Channel List

802.11b/g/n HT20			
Channel	Frequency(MHz)	Channel	Frequency(MHz)
01	2412	07	2442
02	2417	08	2447
03	2422	09	2452
04	2427	10	2457
05	2432	11	2462
06	2437	--	--

Test Frequencies in each operating band

Frequency range over which the device operates in each operating band (Note 1)	Number of test frequencies required	Location of test frequencies inside the operating frequency range (Note 1,2)
≤ 1 MHz	1	near center
> 1 MHz and ≤ 10 MHz	2	1 near high end, 1 near low end
> 10 MHz	3	1 near high end, 1 near center, and 1 near low end

Note 1: The frequency range over which the device operates in a given operating band is the difference between the highest and lowest frequencies on which the device can be tuned within that given operating band. The frequency range can be smaller than or equal to the operating band, but cannot be greater than the operating band.

Note 2: In the third column of table 1, “near” means as close as possible to or at the center / low end / high end of the frequency range over which the device operates.

Firmware / Software Version

1	Product Name	Network Camera
2	Model No.	WPR210-FTEL
3	Test SW Version	Putty Ver 0.63.0.0
4	RF power setting in TEST SW	<input type="checkbox"/> RF power setting was not able to alter during testing. <input checked="" type="checkbox"/> RF power setting was able to alter during testing. (See the following table)

Parameters of test software setting

Type of Modulation	Channel	Frequency (MHz)	Set Value			
			Chain A	Chain B	Chain C	Chain D
802.11b	01	2412	38	--	--	--
	06	2437	37	--	--	--
	11	2462	42	--	--	--
802.11g	01	2412	60	--	--	--
	06	2437	60	--	--	--
	11	2462	55	--	--	--
802.11n HT20	01	2412	59	--	--	--
	06	2437	59	--	--	--
	11	2462	57	--	--	--

1.4 Test Mode Applicability And Tested Channel Detail

1. This device is a Network Camera with a built-in Wi-Fi transceiver.
2. These tests were performed on a sample of equipment to demonstrate compliance with 47 CFR FCC Part 15, Subpart C (Section 15.247).
3. Pre-Scan has been conducted to determine the worst-case mode from all possible combinations between available modulations, data rates, XYZ axis and antenna ports.
4. The worst case was found when positioned on X axis for radiated emission. Following test modes were selected for the final test, and the final worst case is recorded in the report:

EUT Configure Mode	RE < 1G	RE ≥ 1G	ACM	ACP	Description
--	☒	☒	☒	☒	Transmit WIFI

Note : RE<1G: Radiated Emission below 1GHz RE≥1G: Radiated Emission above 1GHz
 ACM: Antenna Port Conducted Measurement ACP: AC Power Line Conducted Emission

Following channel(s) was (were) selected for the final test as listed below:

Radiated Spurious Emission Measurement(Below 1GHz):

EUT Configure Mode	Mode	Available Channel	Tested Channel	Modulation Type	Data Rate (Mbps)
--	802.11g	1 ~ 11	06	DSSS	1

Radiated Spurious Emission Measurement(Above 1GHz):

EUT Configure Mode	Mode	Available Channel	Tested Channel	Modulation Type	Data Rate (Mbps)
--	802.11b	1 ~ 11	01, 06, 11	DSSS	1
--	802.11g	1 ~ 11	01, 06, 11	OFDM	6
--	802.11n HT20	1 ~ 11	01, 06, 11	OFDM	6.5

Radiated Band Edge Emission Measurement(Above 1GHz):

EUT Configure Mode	Mode	Available Channel	Tested Channel	Modulation Type	Data Rate (Mbps)
--	802.11b	1 ~ 11	01, 11	DSSS	1
--	802.11g	1 ~ 11	01, 11	OFDM	6
--	802.11n HT20	1 ~ 11	01, 11	OFDM	6.5

Peak Output Power, 6dB Bandwidth, Power Spectral Density, Conducted Spurious Emission:

EUT Configure Mode	Mode	Available Channel	Tested Channel	Modulation Type	Data Rate (Mbps)
--	802.11b	1 ~ 11	01, 06, 11	DSSS	1
--	802.11g	1 ~ 11	01, 06, 11	OFDM	6
--	802.11n HT20	1 ~ 11	01, 06, 11	OFDM	6.5

Conducted Band Edges:

EUT Configure Mode	Mode	Available Channel	Tested Channel	Modulation Type	Data Rate (Mbps)
--	802.11b	1 ~ 11	01, 11	DSSS	1
--	802.11g	1 ~ 11	01, 11	OFDM	6
--	802.11n HT20	1 ~ 11	01, 11	OFDM	6.5

AC Conducted Emission:

EUT Configure Mode	Mode	Available Channel	Tested Channel	Modulation Type	Data Rate (Mbps)
--	802.11g	1 ~ 11	06	DSSS	1

1.5 Configuration of Tested System

Radiation

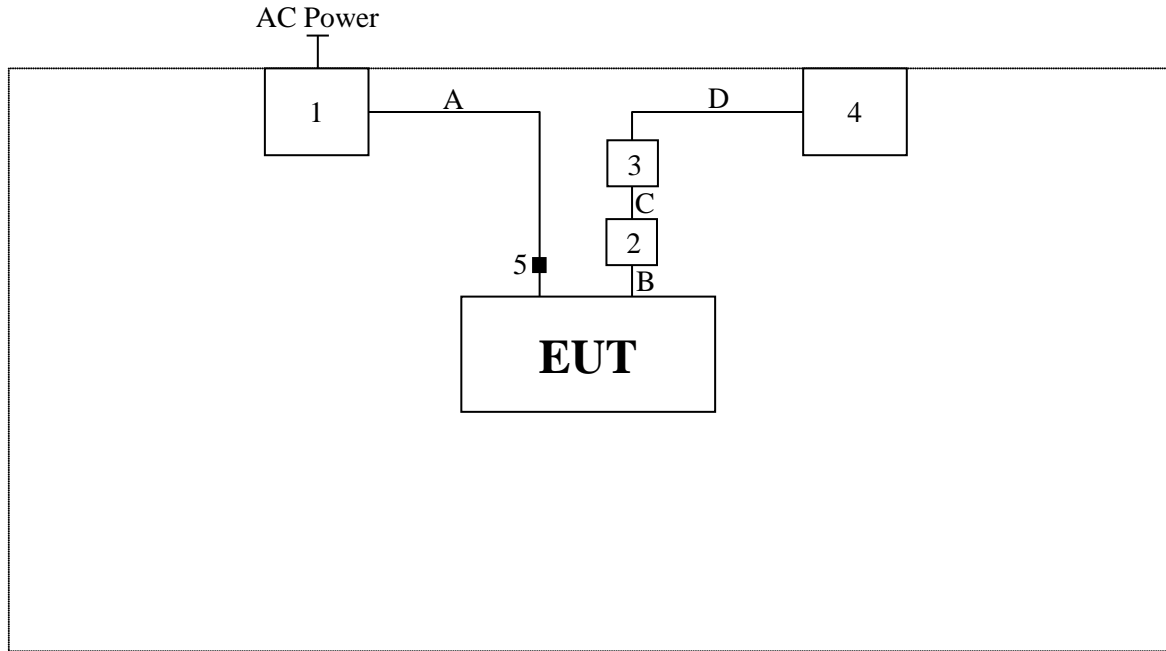

Test Table

AC Conduction

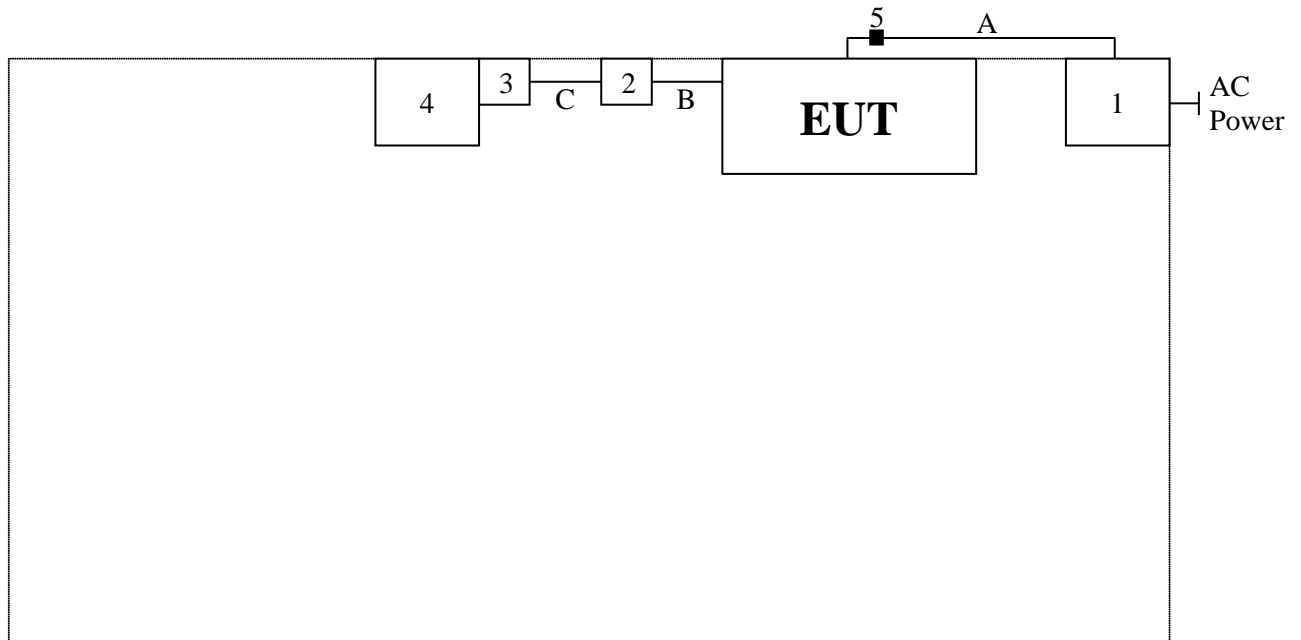

Test Table

1.6 EUT Exercise Software

1. Setup the EUT as shown in Section 1.5
2. Execute software “Putty Ver 0.63.0.0”.
3. Configure the test mode, the test channel, and the data rate.
4. Press “OK” to start the continuous transmit.
5. Verify that the EUT works properly.

1.7 Tested System Details

The types for all equipment, plus descriptions of all cables used in the tested system (including inserted cards) are:

No.	Product	Manufacturer	Model No.	Serial No.	Power Cord
1	Adapter	KEYU	KA12C-0502000US	N/A	N/A
2	Fixture	vivotek	test fixture board	N/A	N/A
3	Fixture	vivotek	test fixture to usb	N/A	N/A
4	Notebook PC	acer	N16Q1	NXVD4TA023742254707600	N/A
5	core	Nichtek	CR190935151D	N/A	N/A
A	USB Cable	DONG GUAN YI XING ELECTRONICS CO, LTD.	YX-YX0121-1A	N/A	Shielded, Non-Core, 2m
B	Data Cable	vivotek	5pin data cable	N/A	Non-shielded, Non-Core, 0.05m
C	Data Cable	vivotek	3pin data cable	N/A	Non-shielded, Non-Core, 0.2m
D	RS232 to Type-A Cable	UPTECH	UTN401A	N/A	Shielded, Non-Core, 1m

Accessories :

No.	Product	Trademark	Model No.	Power Cord
1	Adapter	KEYU	KA12C-0502000US	N/A
5	core	Nichtek	CR190935151D	N/A
A	USB Cable	DONG GUAN YI XING ELECTRONICS CO, LTD.	YX-YX0121-1A	Shielded, Non-Core, 2m

1.8 Test Facility

Items	Required (IEC 60068-1)
Temperature (°C)	15-35
Humidity (% RH)	25-75
Barometric pressure (mbar)	860-1060

Description: Accredited by TAF
Accredited Number: 2965

Issued by: Wendell Industrial Co., Ltd

Company Address: 6F/6F-1, No.188, Baoqiao Rd., Xindian Dist.,
New Taipei City 23145, Taiwan R.O.C

Test Lab: Wendell EMC & RF Laboratory

Lab Address: 5F-1, No.188, Baoqiao Rd., Xindian Dist.,
New Taipei City 23145, Taiwan R.O.C

Test Location: No. 119, Wugong 3rd Rd., Wugu Dist.,
New Taipei City 248, Taiwan (R.O.C.)

Designation Number: TW0025

Test Firm Registration Number: 665221

1.9 Measurement Uncertainty

ISO/IEC 17025 requires that an estimate of the measurement uncertainties associated with the emissions test results be included in the report. The measurement uncertainties given below are based on a 95% confidence (level based on a coverage factor K=2)

Measurement Project	Condition	Expanded Uncertainty
AC Conducted Emission	0.150 ~ 30 MHz	± 2.64 dB
Radiated Emission	0.009 ~ 30 MHz	± 3.7 dB
	30 ~ 1000 MHz	± 3.9 dB
	1000 ~ 18000 MHz	± 4.5 dB
	18000 ~ 40000 MHz	± 4.3 dB
RF Power, Conducted	Conducted Measuring	± 0.75 dB
Occupied Bandwidth	Conducted Measuring	± 2.4 %
Power Density	Conducted Measuring	± 1.2 dB
Duty Cycle and Dwell Time	Conducted Measuring	± 0.9 %
Conducted Unwanted Emission Strength	Conducted Measuring	± 1.4 dB
DC Power Supply	--	± 2.0 %
Temperature	--	± 0.55 °C
Humidity	--	± 3.1 %

Note: Please note that the measurement uncertainty are provided for informational purpose only and are not used in determining the Pass/Fail results.

1.10 List of Test Equipment

For Conducted measurements / W08-Conducted Measurement

Equipment	Manufacturer	Model No.	Serial No.	Cal. Date	Due Date
✓ Spectrum analyzer	Keysight	N9010A	SG50420005	2024/08/09	2025/08/08
✓ Wideband Peak Power Meter	Anritsu	ML2495A	1733007	2023/09/07	2024/09/06
✓ Pulse Power Sensor + Precision Adaptor	Anritsu	MA2411B	1726022	2023/09/07	2024/09/06
Temperature Chamber	TAICHY	MHK-225LK	1061121	2024/04/19	2025/04/18
Wireless Connectivity Tester	R&S	CMW270	101307	2024/06/04	2025/06/03
✓ Attenuator	MVE	MVE2211-10	CT-9-056	2024/08/08	2026/08/07
Attenuator	MVE	MVE2211-20	CT-9-057	2024/08/08	2026/08/07
Attenuator	MVE	MVE2211-30	CT-9-058	2024/08/08	2026/08/07
Power Divider	MVE	MVE8546	170826003	2024/08/08	2026/08/07
Power Splitter	MVE	MVE8547	170302047	2024/08/10	2026/08/09
DC Power Supply	GW INSTEK	GPC-3060D	GER817636	2024/08/05	2025/08/04

Remark:

1. The equipments are calibrated every one year.
2. The Attenuator/ Divider/ Splitter are calibrated every two year.
3. The test instruments marked with “✓” are used to measure the final test results.

For AC Conduction measurements / W08-CE

	Equipment	Manufacturer	Model No.	Serial No.	Cal. Date	Due Date
✓	EMI Test Receiver	R&S	ESR3	102309	2024/06/21	2025/06/20
✓	2-Line V-Network LISN	R&S	ENV216	101185	2024/06/20	2025/06/19
✓	LISN	SCHWARZBECK	NSLK 8127RC	05028	2024/06/20	2025/06/19
✓	Transient Limiter	EM Electronics Corporation	EM-7600	857	2024/06/24	2025/06/23
✓	50ohm Cable	EMCI	EMCCFD300-BM-BM-5000	170612	2024/06/24	2025/06/23
✓	50 ohm terminal impedance	HUBER+SUHNER	50 ohm terminal impedance	CT-1-109-1	2024/06/20	2025/06/19

Remark:

1. All equipments are calibrated every one year.
2. The test instruments marked with “✓” are used to measure the final test results.
3. Test Software version: FARAD EZ-EMC Ver.EMC-CON 3A1

For Radiated measurements / W08-996-2

Equipment	Manufacturer	Model No.	Serial No.	Cal. Date	Due Date
✓ EMI Receiver	Keysight	N9038A	MY51210173	2023/08/18	2024/08/17
✓ Spectrum Analyzer	Keysight	N9010A	MY52220228	2023/08/18	2024/08/17
✓ Active Loop Antenna	Schwarzbeck	FMZB 1513-60B	00033	2024/05/02	2025/05/01
✓ TRILOG super broad Antenna	Schwarzbeck	VULB 9168	VULB 9168-700 & 20E03	2024/07/23	2025/07/22
✓ Horn Antenna	Schwarzbeck	BBHA 9120D	01767	2023/08/17	2024/08/16
✓ Horn Antenna	Schwarzbeck	BBHA 9170	703	2023/08/21	2024/08/20
✓ Pre-Amplifier	EM	EMC330	060774	2023/08/22	2024/08/21
✓ Pre-Amplifier	EMEC	EM01G18G	060648	2023/08/22	2024/08/21
✓ Pre-Amplifier	JPT	JPA0118-55-303K	1910001800055003	2023/08/22	2024/08/21
✓ Pre-Amplifier	EMCI	EMC184045SE	980515	2023/08/22	2024/08/21
✓ Cable	EMEC	EM-CB400	105060103	2023/08/22	2024/08/21
✓ Cable	EMEC	EM-CB400	105060102	2023/08/22	2024/08/21
✓ Cable	EMEC	EM-CB400	105060101	2023/08/22	2024/08/21
✓ RF Cable	HUBER+SUHNER	SF102	MY2752/2	2023/08/22	2024/08/21
✓ RF Cable	MVE	280280.LL266.1200	B60028C	2023/08/22	2024/08/21
✓ RF Cable	EMCI	EMC102-KM-KM-600	190646	2023/08/22	2024/08/21
✓ RF Cable	MVE	140140.LL404.700	B90014C	2023/08/22	2024/08/21
✓ RF Cable	MVE	140140.LL404.300	B90006C	2023/08/22	2024/08/21
✓ RF Filter	EMEC	BRF-2400-2500	002	2022/08/17	2024/08/16
RF Filter	EMEC	BRF-5150-5350	104	2022/08/17	2024/08/16
RF Filter	EMEC	BRF-5470-5725	092	2022/08/17	2024/08/16
RF Filter	EMEC	BRF-5725-5875	091	2022/08/17	2024/08/16
✓ RF Filter	EMEC	HPF-2800	002	2022/08/17	2024/08/16
RF Filter	EMEC	HPF-5850	059	2022/08/17	2024/08/16
SMA Notch Filter	MVE	MFN-902.928.S1	190604001	2022/08/17	2024/08/16

Remark:

1. The equipments are calibrated every one year.
2. The Filter calibrated every two year.
3. The test instruments marked with “✓” are used to measure the final test results.
4. Test Software version: FARAD EZ-EMC Ver.WD-03A1-1

2 Test Result

2.1 Antenna Requirement

2.1.1 Applicable Standard

An intentional radiator shall be designed to ensure that no antenna other than that furnished by the responsible party shall be used with the device. The use of a permanently attached antenna or of an antenna that uses a unique coupling to the intentional radiator shall be considered sufficient to comply with the provisions of this section. The manufacturer may design the unit so that a broken antenna can be replaced by the user, but the use of a standard antenna jack or electrical connector is prohibited.

An intentional radiator shall be designed to ensure that no antenna other than as furnished by the responsible party shall be used with the device. If transmitting antennas of directional gain greater than 6dBi are using the power shall be reduced by the amount in dB that the directional gain of the antenna exceeds 6 dBi, for compliance to FCC 47CFR 15.247 (c) requirements.

2.1.2 Antenna Connected Construction

Non-standard antenna connector is used.

2.1.3 Antenna Gain

No.	Manufacturer	Model No.	Antenna Type	Peak Gain
1	Wansih	3411EM05002A	FPCB Antenna	3.47 dBi for 2.4GHz

Description of the operating transmit modes :

- * 802.11b : Only one Antenna mode, this port is Ant-1
- * 802.11g : Only one Antenna mode, this port is Ant-1
- * 802.11n_HT20 : Only one Antenna mode, this port is Ant-1

Directional gain calculation & Conducted Output Power limit after correction :

- * 802.11b : Gain = 3.47 dBi \leq 6dBi ;
- * 802.11g : Gain = 3.47 dBi \leq 6dBi ;
- * 802.11n_HT20 : Gain = 3.47 dBi \leq 6dBi ;

Directional gain calculation & Power Spectral Density limit after correction :

- * 802.11b : Gain = 3.47 dBi \leq 6dBi ;
- * 802.11g : Gain = 3.47 dBi \leq 6dBi ;
- * 802.11n_HT20 : Gain = 3.47 dBi \leq 6dBi ;

2.2 Peak Output Power Measurement

2.2.1 Limit

For systems using digital modulation in the 2400-2483.5MHz, the limit for peak output power is 1W. If transmitting antenna of directional gain greater than 6dBi is used, the peak output power from the intentional radiator shall be reduced below the above stated value by the amount in dB that the directional gain of the antenna exceeds 6 dBi. In case of point-to-point operation, the limit has to be reduced by 1dB for every 3dB that the directional gain of the antenna exceeds 6dBi.

2.2.2 Test Setup

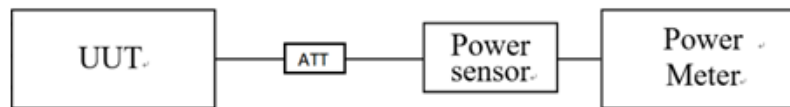

2.2.3 Test Procedure

1. Reference ANSI C63.10 : 2013 chapter 11.9.1.3
2. Enable the EUT transmit continuously.
3. Let EUT be connected to the power meter, and record the max. reading.
4. Measurement using a gated RF average power meter, since this measurement is made only during the ON time of the transmitter, no duty cycle correction is required.

2.2.4 Test Result

Mode	Frequency (MHz)	Peak power (dBm)			Limit (dBm)	Result
		Chain A	Chain B	Total		
802.11b	2412	14.72	--	--	≤ 30	Pass
	2437	14.52	--	--	≤ 30	Pass
	2462	16.64	--	--	≤ 30	Pass
802.11g	2412	24.76	--	--	≤ 30	Pass
	2437	24.81	--	--	≤ 30	Pass
	2462	24.07	--	--	≤ 30	Pass
802.11n HT20	2412	24.65	--	--	≤ 30	Pass
	2437	24.72	--	--	≤ 30	Pass
	2462	24.48	--	--	≤ 30	Pass

Remark:

1. Peak Power = Reading value on power meter + cable loss
2. $10 \log(X/mW) = \text{dBm}$, X=1 watt (Limit)
1 watt = 30 dBm

2.3 6dB Bandwidth Measurement

2.3.1 Limit

The minimum 6 dB bandwidth shall be at least 500 kHz.

2.3.2 Test Setup



2.3.3 Test Procedure

1. Reference ANSI C63.10 : 2013 chapter 11.8.2
2. Enable the EUT transmit continuously.
3. Spectrum analyzer set:
 - a) RBW = 100 kHz
 - b) VBW \geq 3 RBW
 - c) Detector = peak
 - d) Sweep time = auto couple
 - e) Trace mode = max hold.

2.3.4 Test Result

802.11b

Frequency (MHz)	6dB BW (kHz)		Limit (kHz)	Result
	Chain A	Chain B		
2412	9060	--	≥ 500	Pass
2437	9051	--	≥ 500	Pass
2462	8541	--	≥ 500	Pass

Chain A

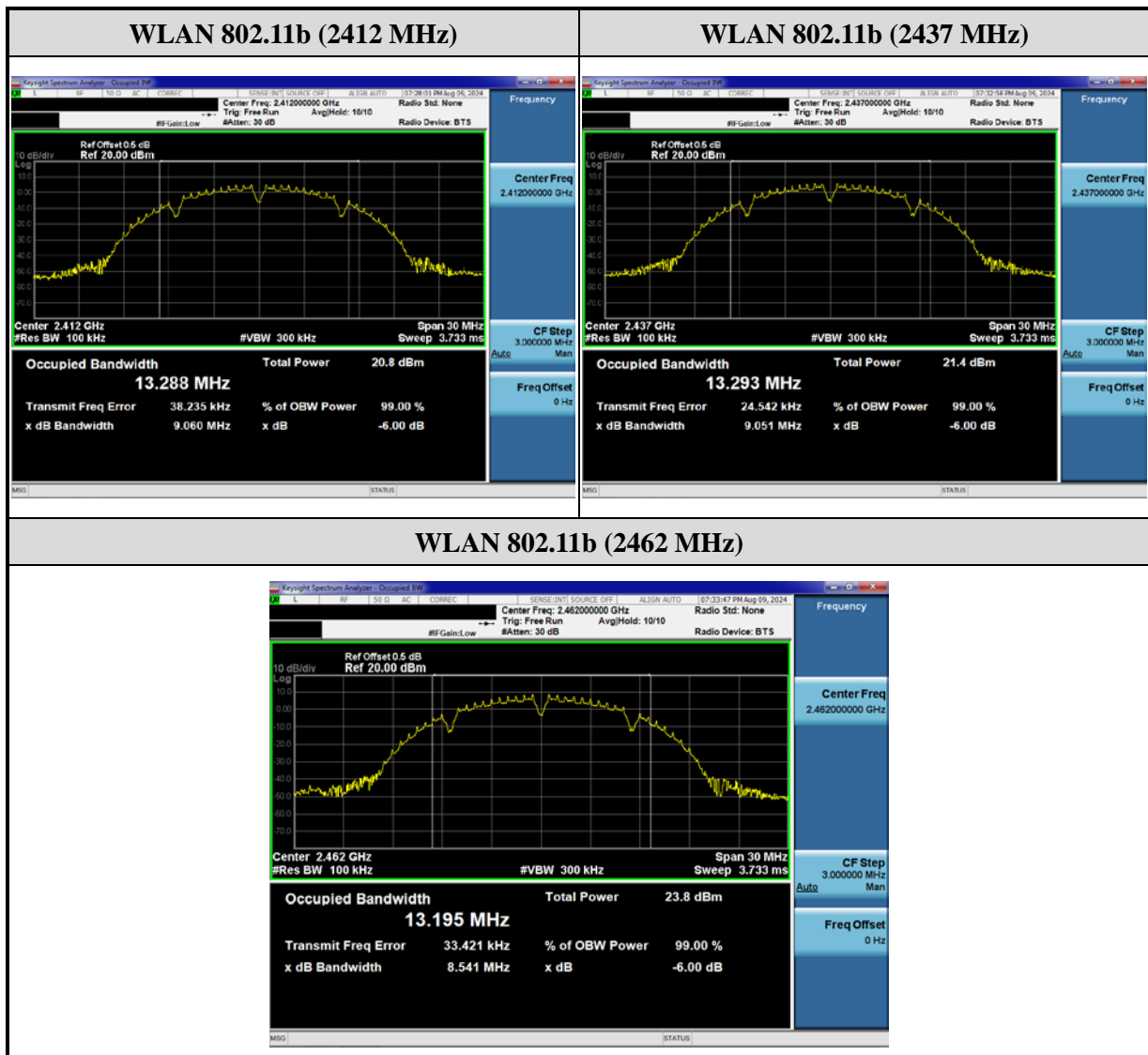

802.11g

Frequency (MHz)	6dB BW (kHz)		Limit (kHz)	Result
	Chain A	Chain B		
2412	16370	--	≥ 500	Pass
2437	16370	--	≥ 500	Pass
2462	16350	--	≥ 500	Pass

Chain A

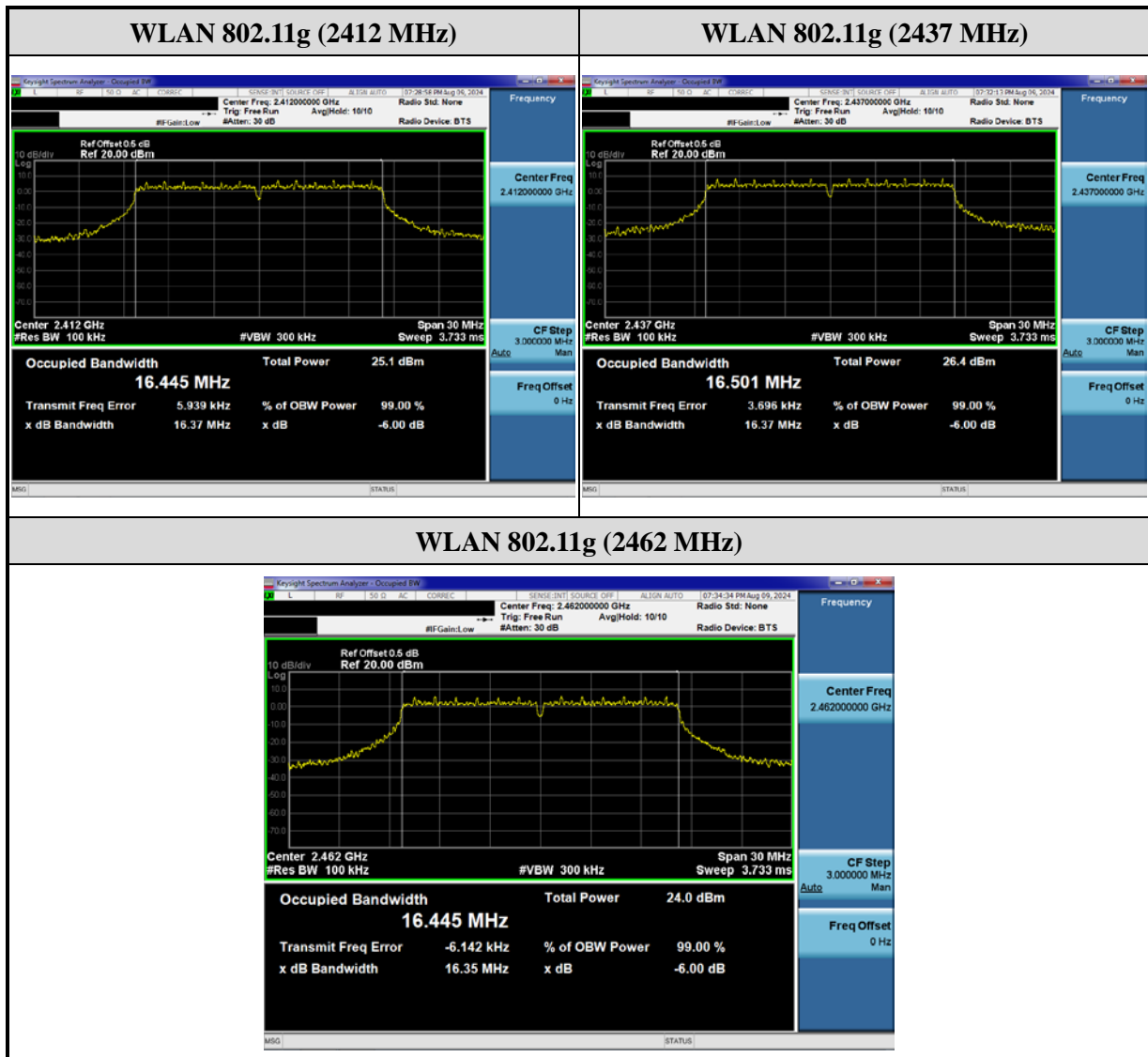

802.11n HT20

Frequency (MHz)	6dB BW (kHz)		Limit (kHz)	Result
	Chain A	Chain B		
2412	17570	--	≥ 500	Pass
2437	17560	--	≥ 500	Pass
2462	17550	--	≥ 500	Pass

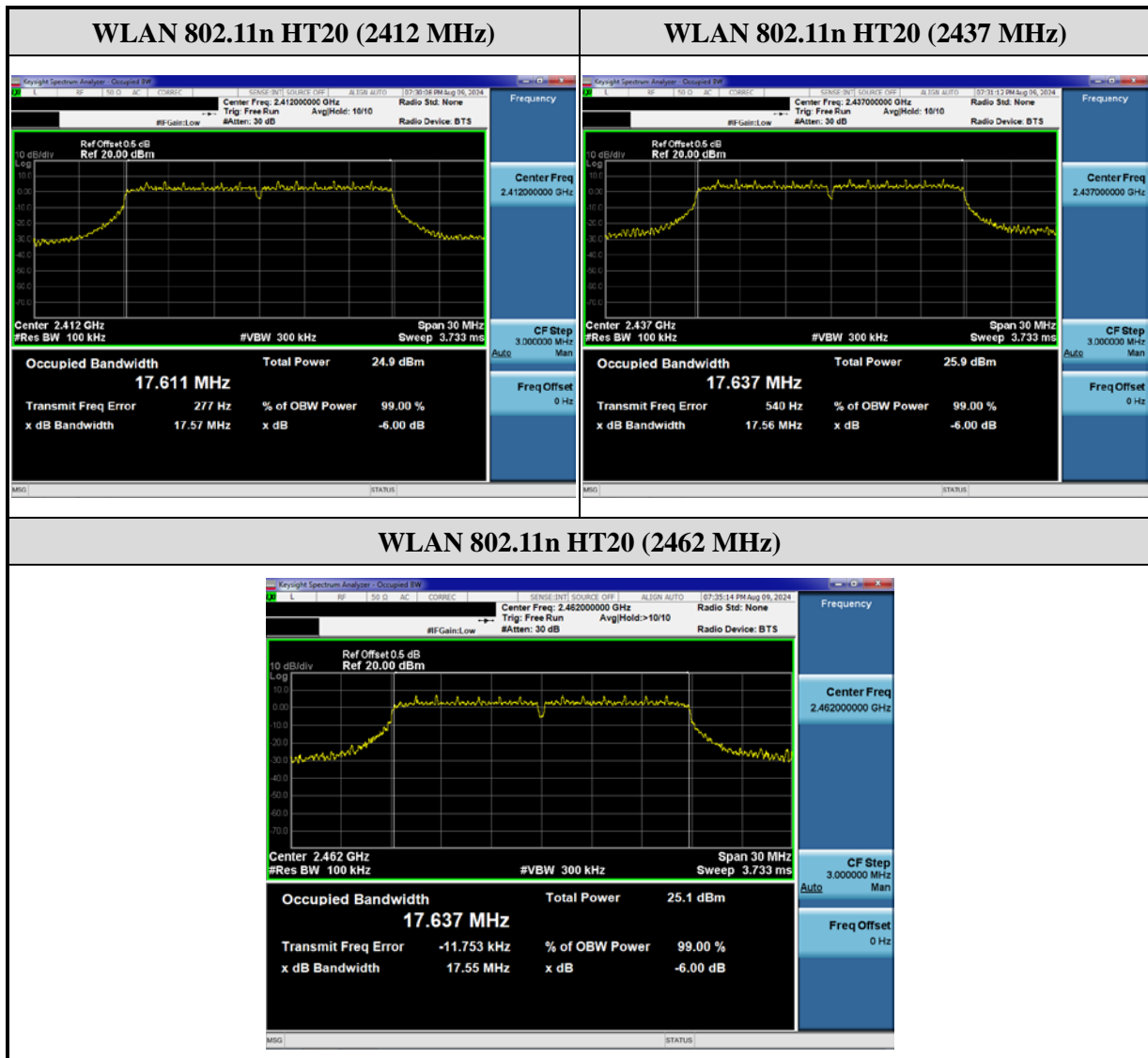
Chain A

2.4 Power Spectral Density Measurement

2.4.1 Limit

The peak power spectral density shall not be greater than 8dBm in any 3kHz band at any time interval of continuous transmission.

2.4.2 Test Setup



2.4.3 Test Procedure

1. Reference ANSI C63.10 : 2013 chapter 11.10.2
2. Enable the EUT transmit continuously.
3. Spectrum analyzer set:
 - a) RBW = 3 kHz ~ 100 kHz
 - b) VBW \geq 3 RBW
 - c) Span = 1.5 times DTS Channel 6dB Bandwidth
 - d) Detector = peak
 - e) Sweep time = auto couple
 - f) Trace mode = max hold.

2.4.4 Test Result

802.11b

Frequency (MHz)	Power Spectral Density (dBm)			Limit (dBm)	Result
	Chain A	Chain B	Total		
2412	-6.234	--	--	≤ 8	Pass
2437	-6.700	--	--	≤ 8	Pass
2462	-4.830	--	--	≤ 8	Pass

Remark: PSD = Reading value on spectrum analyzer + cable loss

Chain A

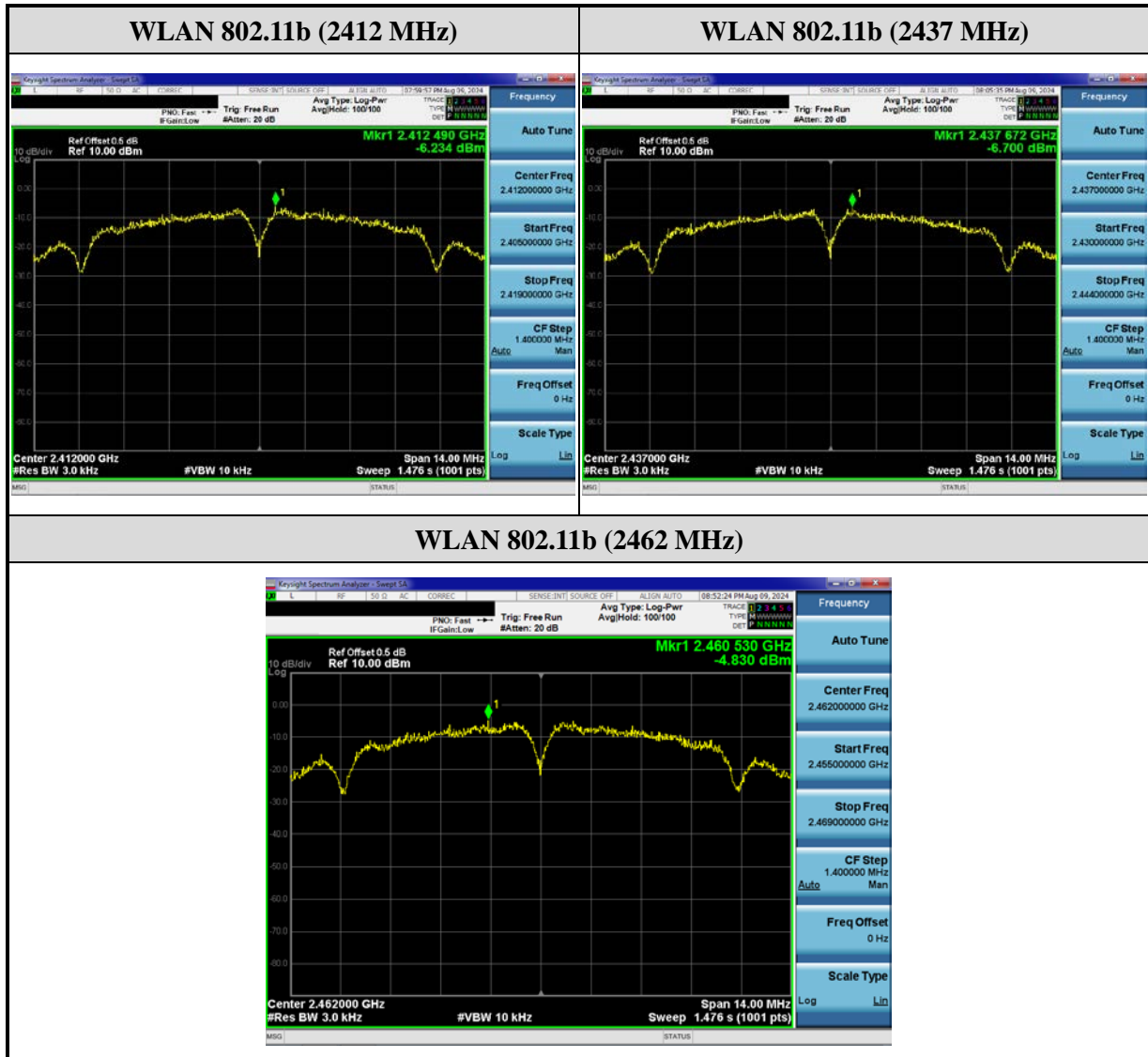

802.11g

Frequency (MHz)	Power Spectral Density (dBm)			Limit (dBm)	Result
	Chain A	Chain B	Total		
2412	-6.172	--	--	≤ 8	Pass
2437	-5.082	--	--	≤ 8	Pass
2462	-6.754	--	--	≤ 8	Pass

Remark: PSD = Reading value on spectrum analyzer + cable loss

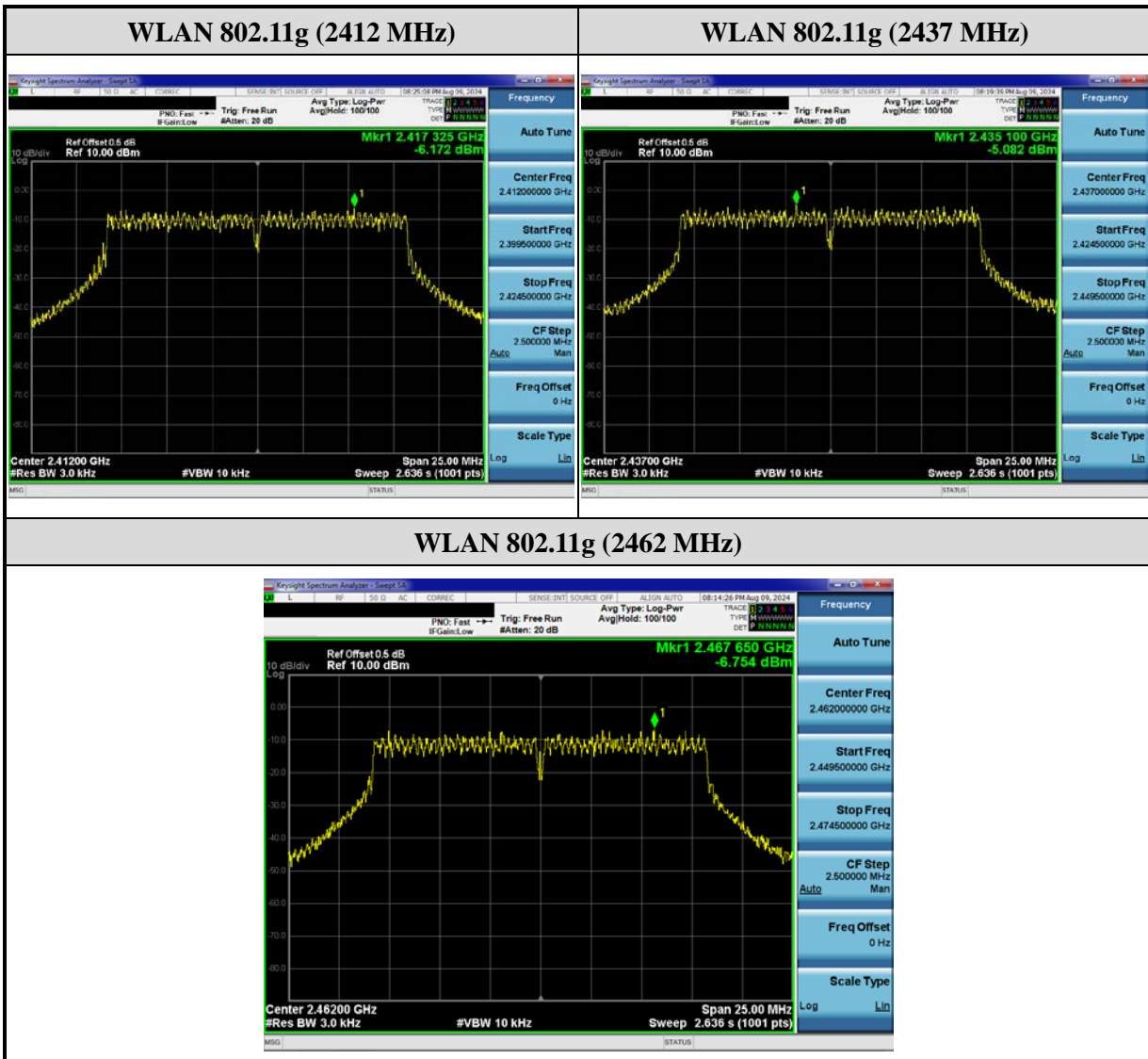
Chain A

802.11n HT20

Frequency (MHz)	Power Spectral Density (dBm)			Limit (dBm)	Result
	Chain A	Chain B	Total		
2412	-6.423	--	--	≤ 8	Pass
2437	-6.207	--	--	≤ 8	Pass
2462	-6.195	--	--	≤ 8	Pass

Remark:

1. PSD = Reading value on spectrum analyzer + cable loss
2. Section E) method 2) b) of power density measurement of KDB 662911 is used for calculating total power density.

Chain A

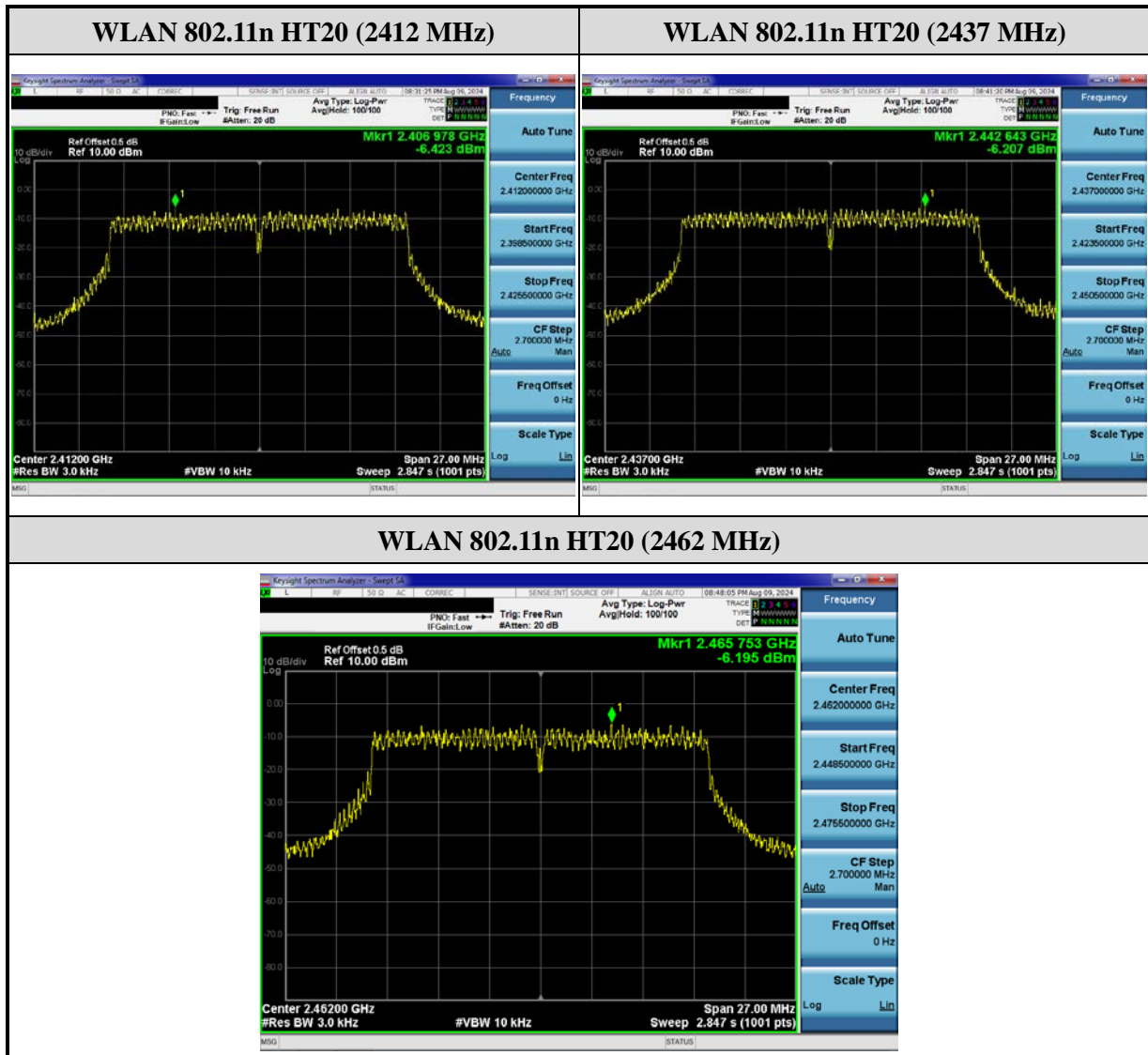

2.5 Conducted Band Edges and Spurious Emission Measurement

2.5.1 Limit

In any 100 KHz bandwidth outside the frequency bands in which the spread spectrum intentional radiator is operating, the radio frequency power that is produced by the intentional radiator shall be at least 20dB below that in the 100KHz bandwidth within the band that contains the highest level of the desired power, In addition, radiated emissions which fall in the restricted bands, as defined in must also comply with the radiated emission limits. If the transmitter complies with the conducted power limits based on the use of RMS averaging over a time interval, the attenuation required under this paragraph shall be 30 dB instead of 20 dB

2.5.2 Test Setup



2.5.3 Test Procedure

1. Reference ANSI C63.10 : 2013 chapter 6.10
2. Enable the EUT transmit continuously.
3. Spectrum analyzer set :
 - a) RBW = 100 kHz
 - b) VBW \geq 3 RBW
 - c) Detector = peak
 - d) Sweep time = auto couple
 - e) Trace mode = max hold.

2.5.4 Test Result

Chain A

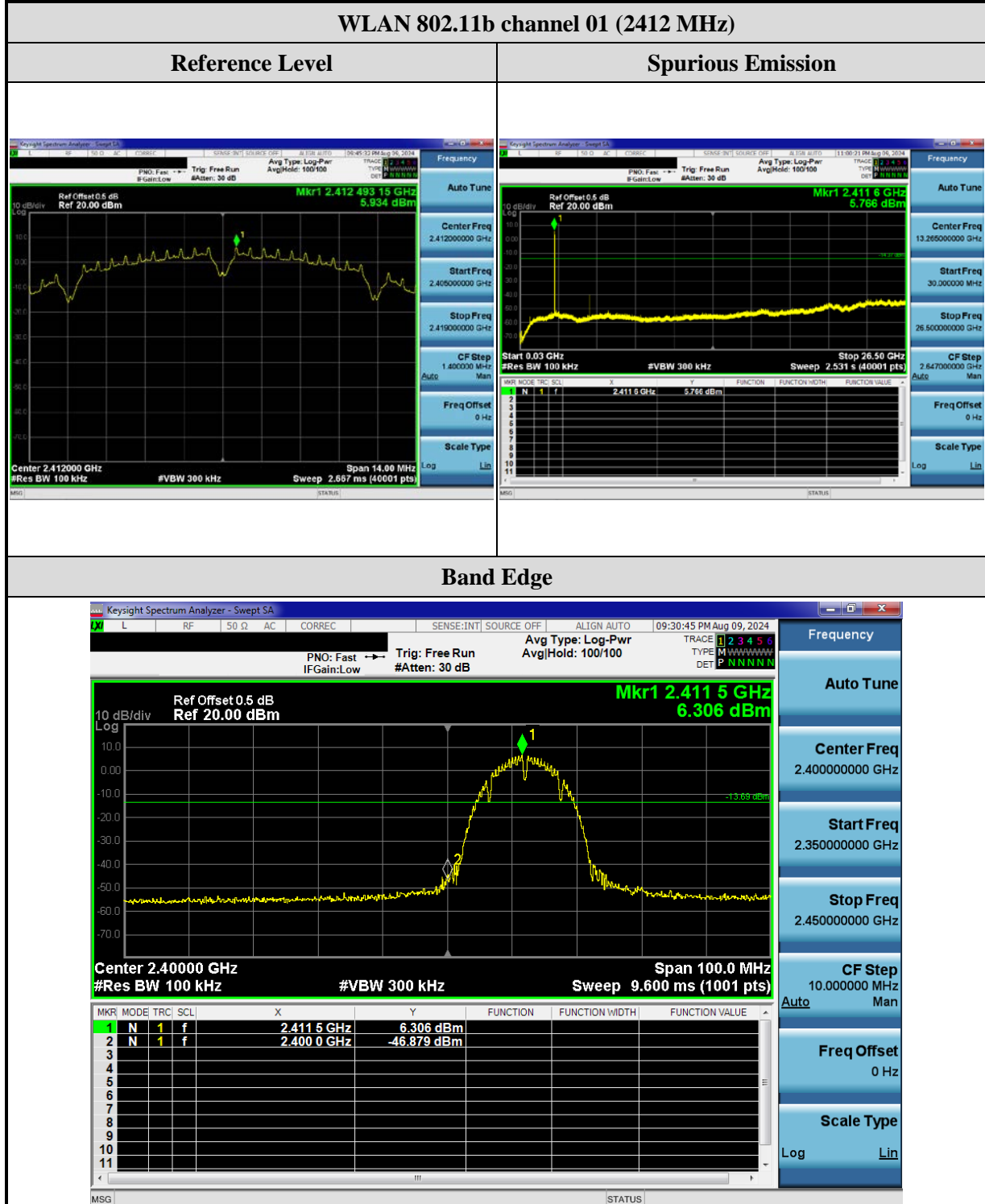

Chain A

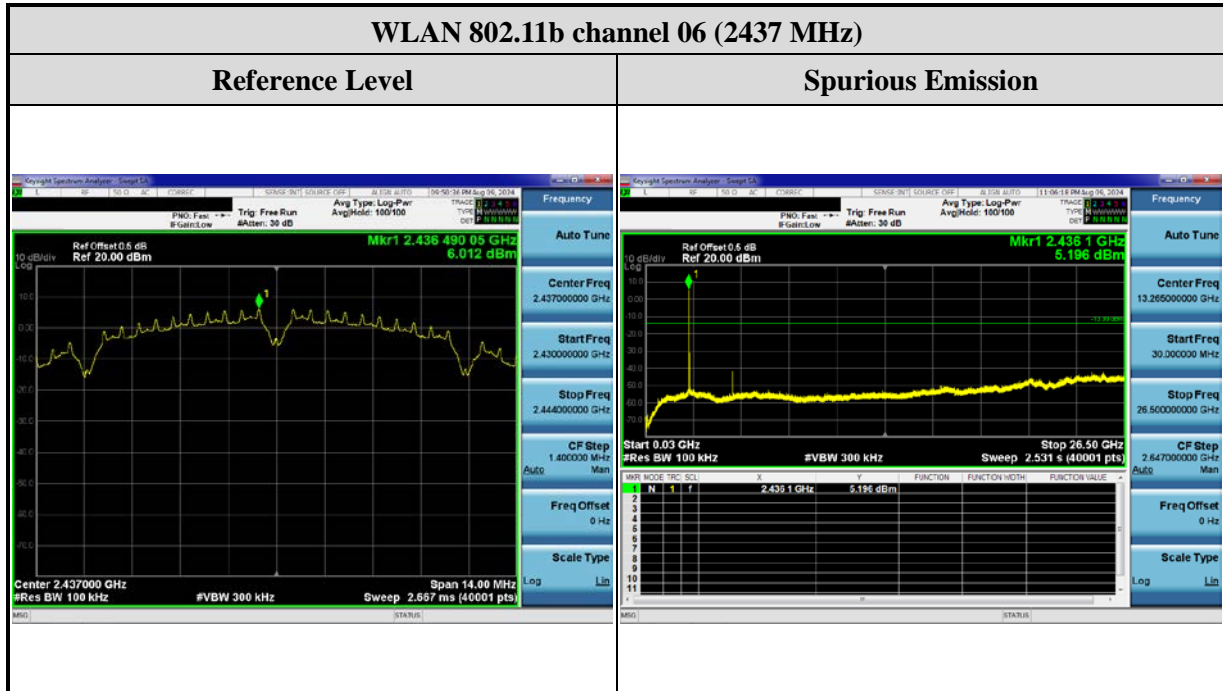

Chain A

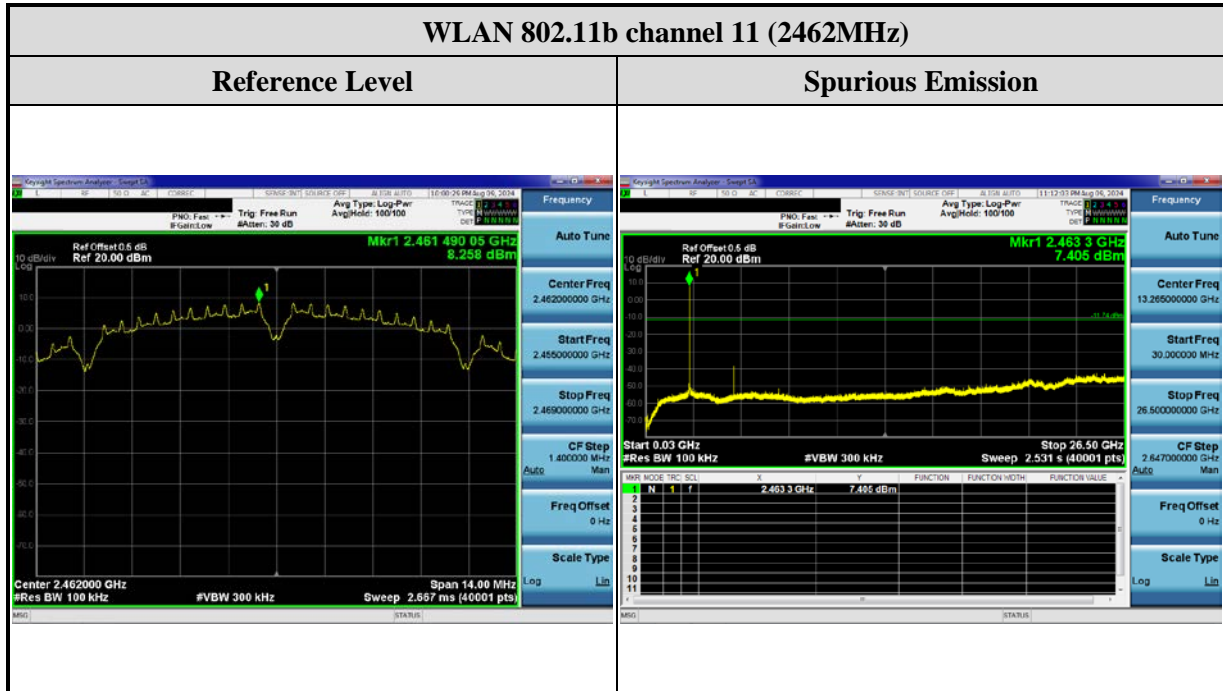

Band Edge

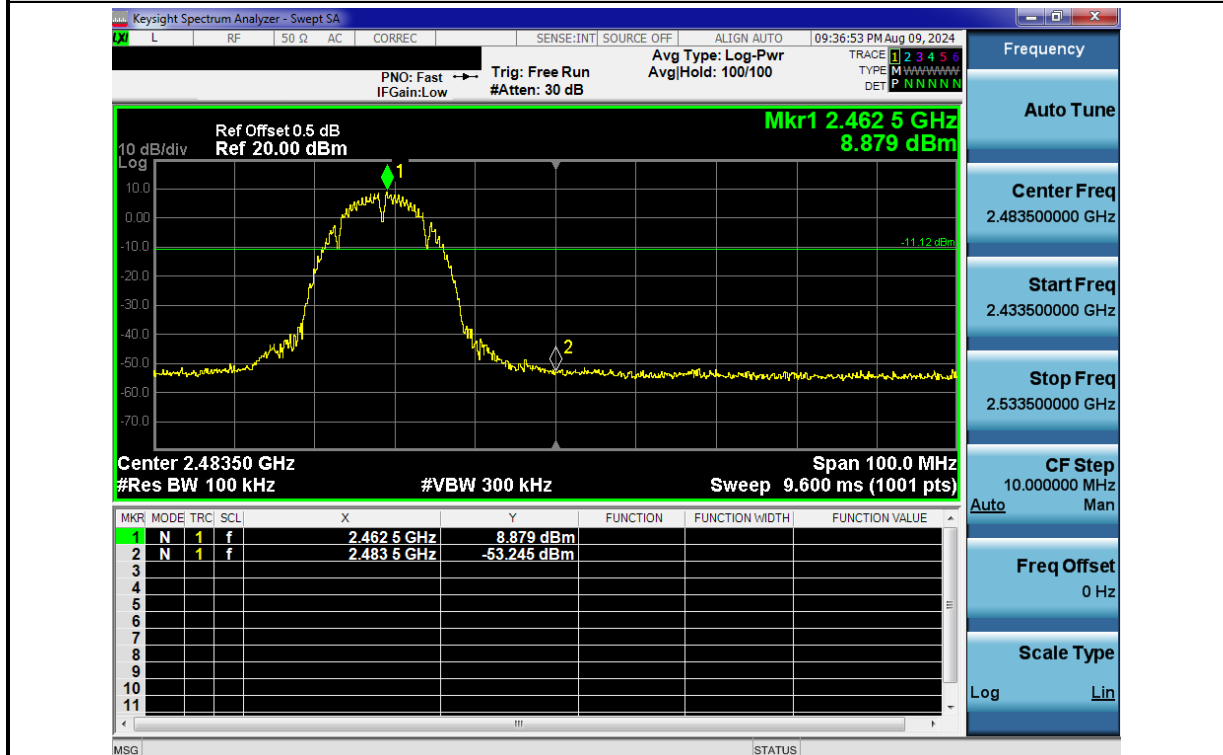

Chain A

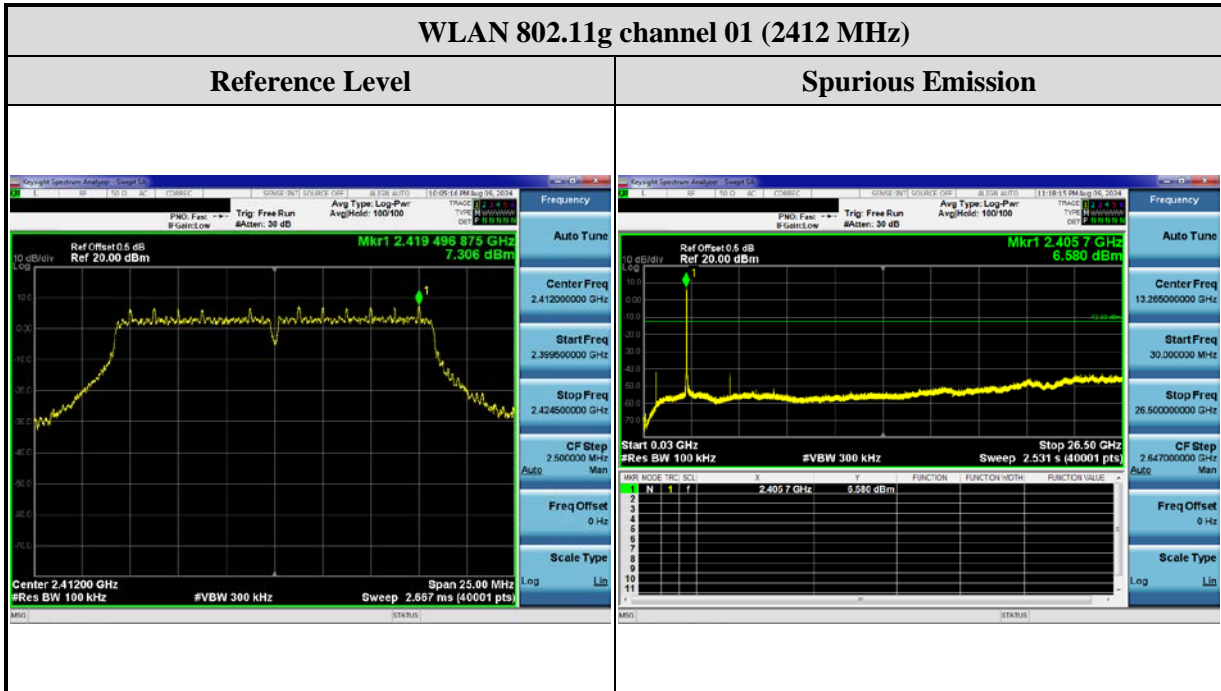

Band Edge



Chain A

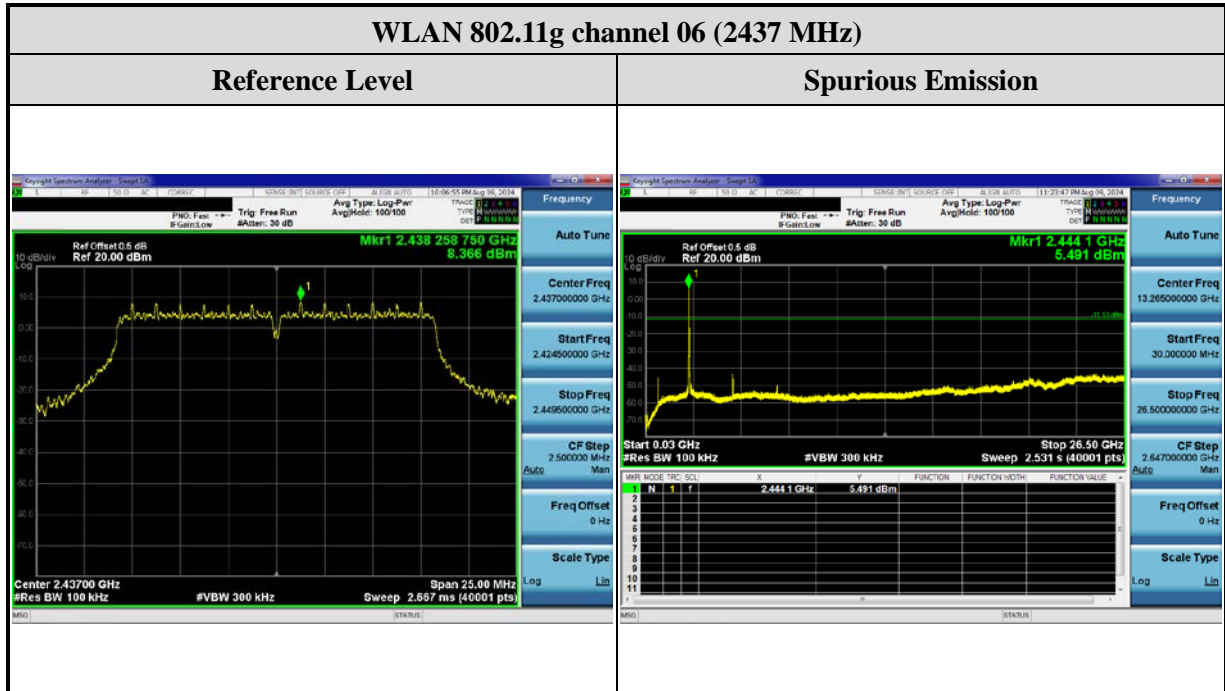

Chain A

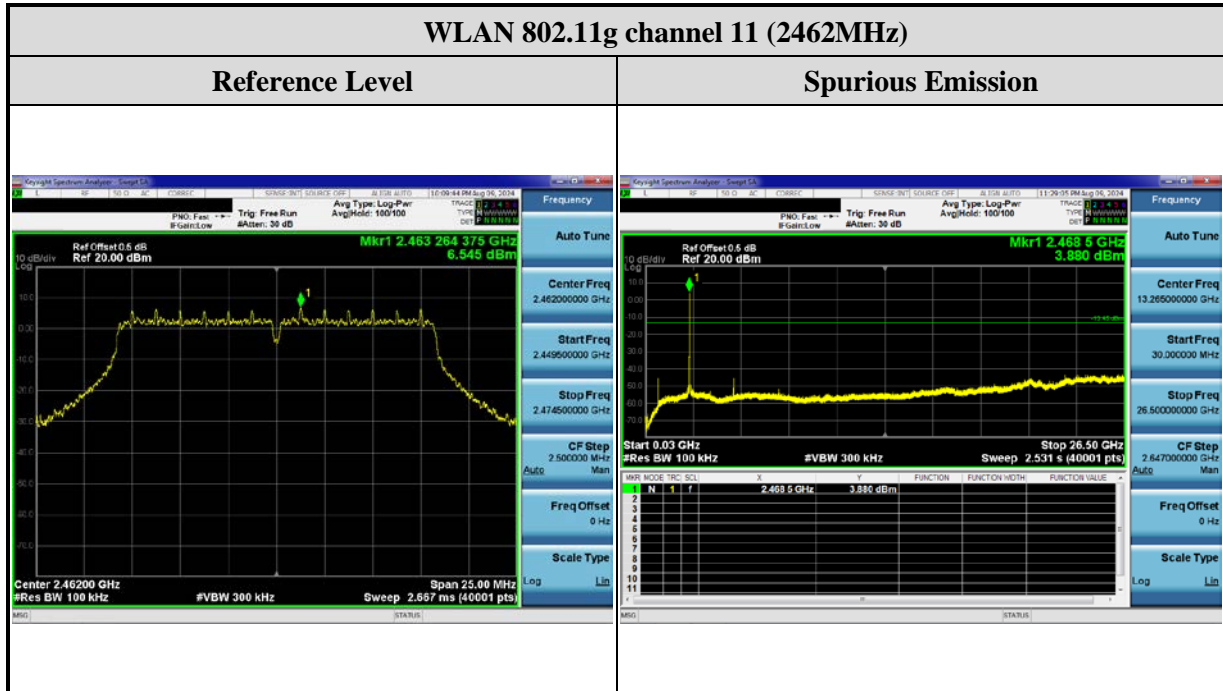

Band Edge



Chain A

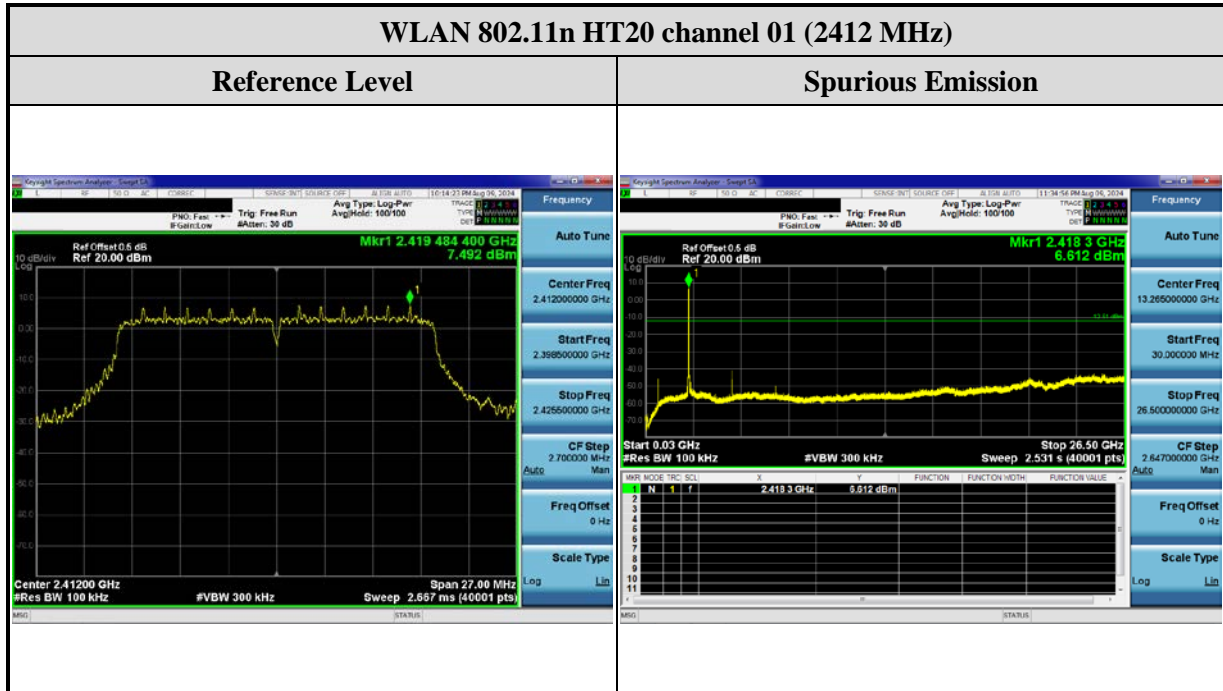

Band Edge



Chain A

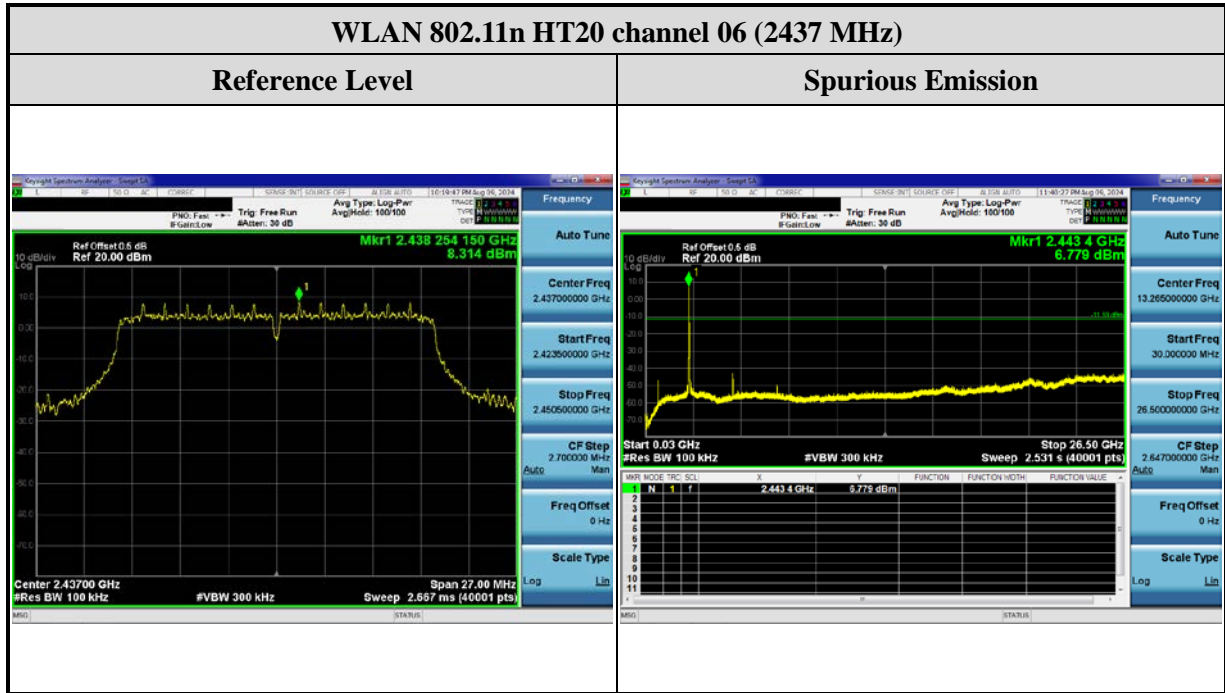

Chain A

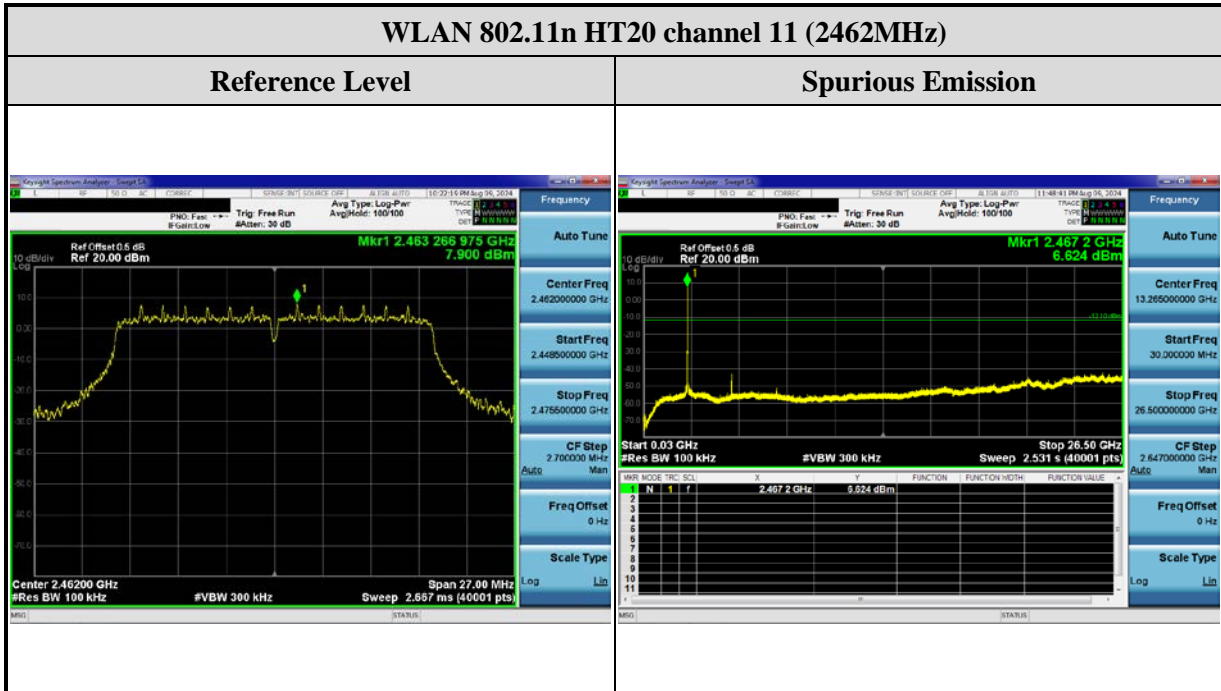

Band Edge



2.6 Radiated Band Edges and Spurious Emission Measurement

2.6.1 Limit

Frequency (MHz)	Field Strength ($\mu\text{V}/\text{m}$)	Measurement Distance (m)
0.009 – 0.490	$2400/F(\text{kHz})$	300
0.490 – 1.705	$24000/F(\text{kHz})$	30
1.705 – 30.0	30	30
30 – 88	100	3
88 – 216	150	3
216 - 960	200	3
Above 960	500	3

Remarks:

1. RF Voltage (dBuV) = $20 \log \text{RF Voltage}(\mu\text{V})$
2. In the Above Table, the tighter limit applies at the band edges.
3. Distance refers to the distance in meters between the measuring instrument antenna and the closed point of any part of the device or system

2.6.2 Test Setup

Below 30MHz

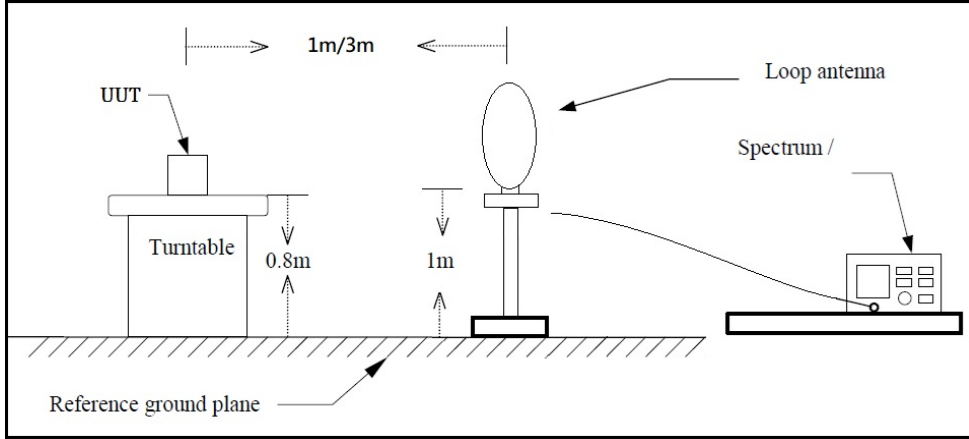

30MHz~1GHz

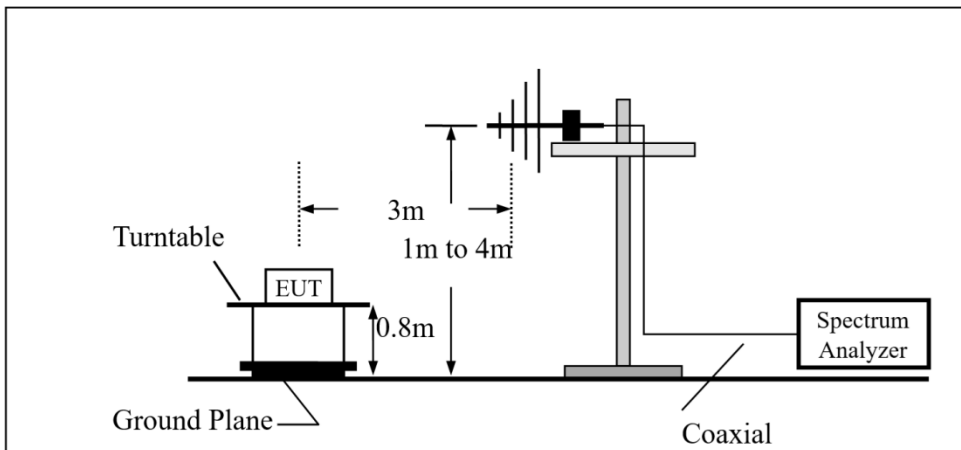

Above 1GHz

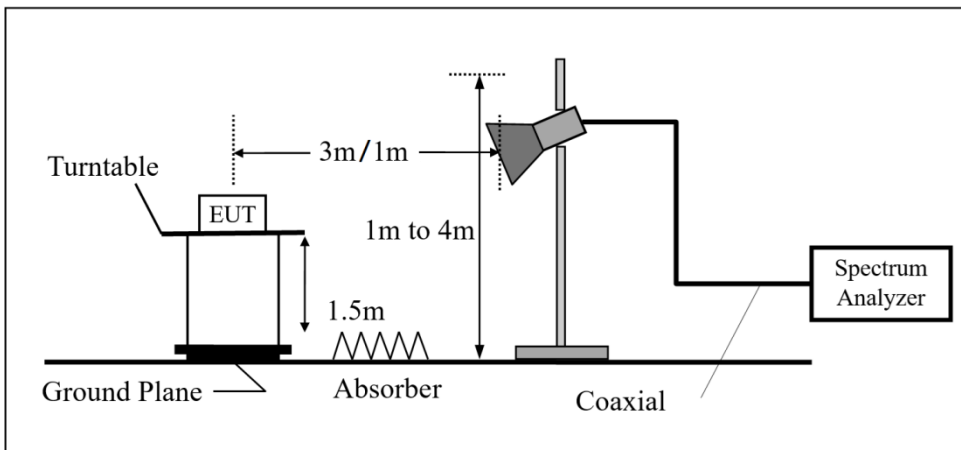

2.6.3 Test Procedure

The EUT was setup according to ANSI C63.10 : 2013 chapter 6.4, 6.5, 6.6 and tested according test procedure of KDB 558074 for compliance to FCC 47CFR 15.247 requirements.

- (1) The EUT was placed on the top of a rotating table 0.8 meters (for below 1GHz) / 1.5 meters (for above 1GHz) above the ground at 3 meters chamber room for the test. The table was rotated 360 degrees to determine the position of the highest radiation.
- (2) The EUT was set 3 meters away from the interference-receiving antenna, the height of the antenna is varied from 1 meter to 4 meters above the ground to determine the maximum value of the field strength.
- (3) Parallel, perpendicular, and ground-parallel orientations of the antenna are set to make the measurement.
- (4) For each suspected emission, the EUT was arranged to its worst case and the rotatable table was turned from 0 degrees to 360 degrees to find the maximum reading.
- (5) The test-receiver system was set to quasi-peak detect function and specified bandwidth with maximum hold mode when the test frequency is below 1 GHz.
- (6) The test-receiver system was set to peak and average detect function and specified bandwidth with maximum hold mode when the test frequency is above 1 GHz. If the peak reading value also meets the average limit, measurement with the average detector is unnecessary.

Remarks:

- (a) The resolution bandwidth and video bandwidth of test receiver/spectrum analyzer is 120kHz for Quasi-peak detection at frequency below 1GHz.
- (b) The resolution bandwidth of test receiver/spectrum analyzer is 1MHz and video bandwidth is 3MHz for Peak detection at frequency above 1GHz.
- (c) The resolution bandwidth of test receiver/spectrum analyzer is 1MHz and the video bandwidth is $\geq 1/T$ (Duty cycle < 98%) or 10Hz(Duty cycle > 98%) for Average detection (AV) at frequency above 1GHz.
- (d) All modes of operation were investigated and the worst-case emissions are reported.

For Radiated emission below 30MHz

- (1) The EUT was placed on the top of a rotating table 0.8 meters above the ground in a 3 meter chamber room. The table was rotated 360 degrees to determine the position of the highest radiation.
- (2) The EUT was set 3 meters away from the interference-receiving antenna, which was mounted on the top of a variable-height antenna tower.
- (3) Parallel, perpendicular, and ground-parallel orientations of the antenna are set to make the measurement.
- (4) For each suspected emission, the EUT was arranged to its worst case and the rotatable table was turned from 0 degrees to 360 degrees to find the maximum reading.
- (5) The test-receiver system was set to Quasi-Peak Detect Function and Specified Bandwidth with Maximum Hold Mode.

For Radiated emission Above 30MHz

- (7) The EUT was placed on the top of a rotating table 0.8 meters (for below 1GHz) / 1.5 meters (for above 1GHz) above the ground at 3 meter chamber room for the test. The table was rotated 360 degrees to determine the position of the highest radiation.
- (8) The EUT was set 3 meters away from the interference-receiving antenna, the height of the antenna is varied from 1 meter to 4 meters above the ground to determine the maximum value of the field strength.
- (9) Parallel, perpendicular, and ground-parallel orientations of the antenna are set to make the measurement.
- (10) For each suspected emission, the EUT was arranged to its worst case and the rotatable table was turned from 0 degrees to 360 degrees to find the maximum reading.
- (11) The test-receiver system was set to quasi-peak detect function and specified bandwidth with maximum hold mode when the test frequency is below 1 GHz.
- (12) The test-receiver system was set to peak and average detect function and specified bandwidth with maximum hold mode when the test frequency is above 1 GHz. If the peak reading value also meets the average limit, measurement with the average detector is unnecessary.

2.6.4 Duty Cycle

Mode	Frequency (MHz)	on time (ms)	on+off time (ms)	Duty cycle	Duty Factor (dB)	1/T Minimum VBW (kHz)
802.11b	2412	12.550	12.640	0.993	0.031	0.010
802.11g	2412	2.100	3.960	0.530	2.755	0.476
802.11n HT20	2412	1.950	4.035	0.483	3.158	0.513

2.6.5 Test Result of Radiated Band Edge Measurement

The following tables for radiated measurement, pre-scanned in three orthogonal panels, X, Y, Z. The worst cases (X axis) were recorded in this report.

Test Frequency	
RF	802.11b / 802.11g / 802.11n HT20
Tx	CH01 (2412MHz) CH11 (2462MHz)

Test Mode :	Transmit(802.11b)	Test Date :	2024/07/27
Test Channel :	CH01(2412MHz)	Temperature :	25.8 °C
Polarization :	Horizontal	Relative Humidity :	62 %

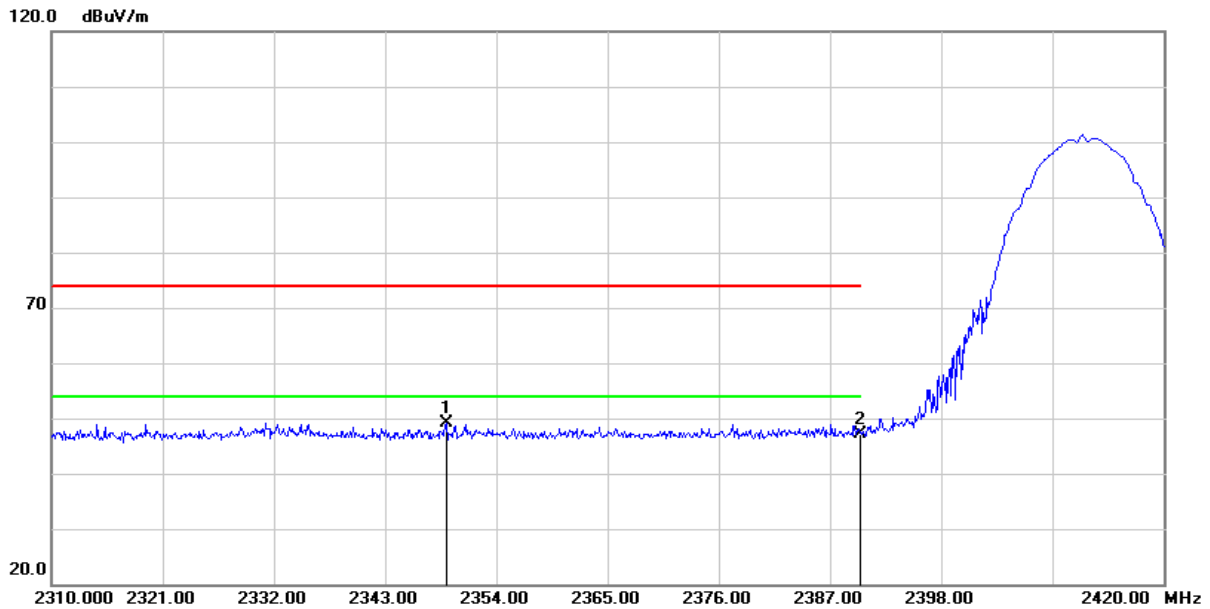

No.	Frequency (MHz)	Reading (dBuV/m)	Correct Factor (dB/m)	Result (dBuV/m)	Limit (dBuV/m)	Margin (dB)	Remark
1	2349.050	54.92	-5.70	49.22	74.00	-24.78	peak
2	2390.000	52.90	-5.69	47.21	74.00	-26.79	peak

Remark :

1. Correction Factor = Antenna factor + Cable loss – Amplifier gain
2. Result Value = Reading Level + Correct Factor
3. Margin Level = Result Value – Limit Value
4. The other emission levels were very low against the limit

Test Mode :	Transmit(802.11b)	Test Date :	2024/07/27
Test Channel :	CH01(2412MHz)	Temperature :	25.8 °C
Polarization :	Vertical	Relative Humidity :	62 %

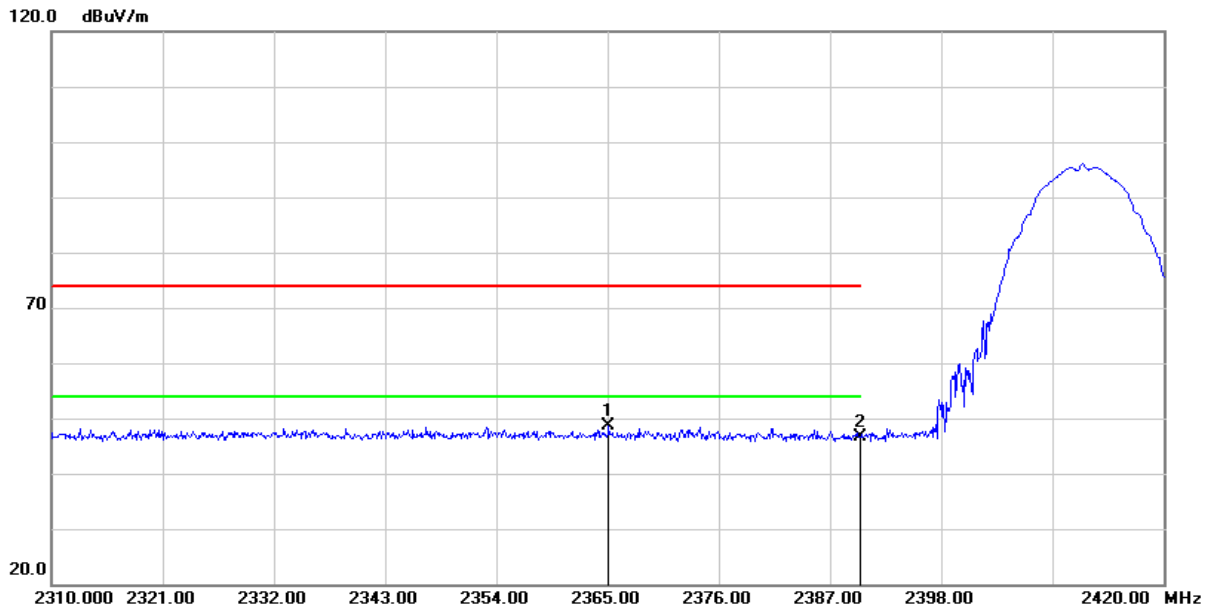

No.	Frequency (MHz)	Reading (dBuV/m)	Correct Factor (dB/m)	Result (dBuV/m)	Limit (dBuV/m)	Margin (dB)	Remark
1	2365.110	54.25	-5.70	48.55	74.00	-25.45	peak
2	2390.000	52.32	-5.69	46.63	74.00	-27.37	peak

Remark :

1. Correction Factor = Antenna factor + Cable loss – Amplifier gain
2. Result Value = Reading Level + Correct Factor
3. Margin Level = Result Value – Limit Value
4. The other emission levels were very low against the limit

Test Mode :	Transmit(802.11b)	Test Date :	2024/07/27
Test Channel :	CH11(2462MHz)	Temperature :	25.8 °C
Polarization :	Horizontal	Relative Humidity :	62 %

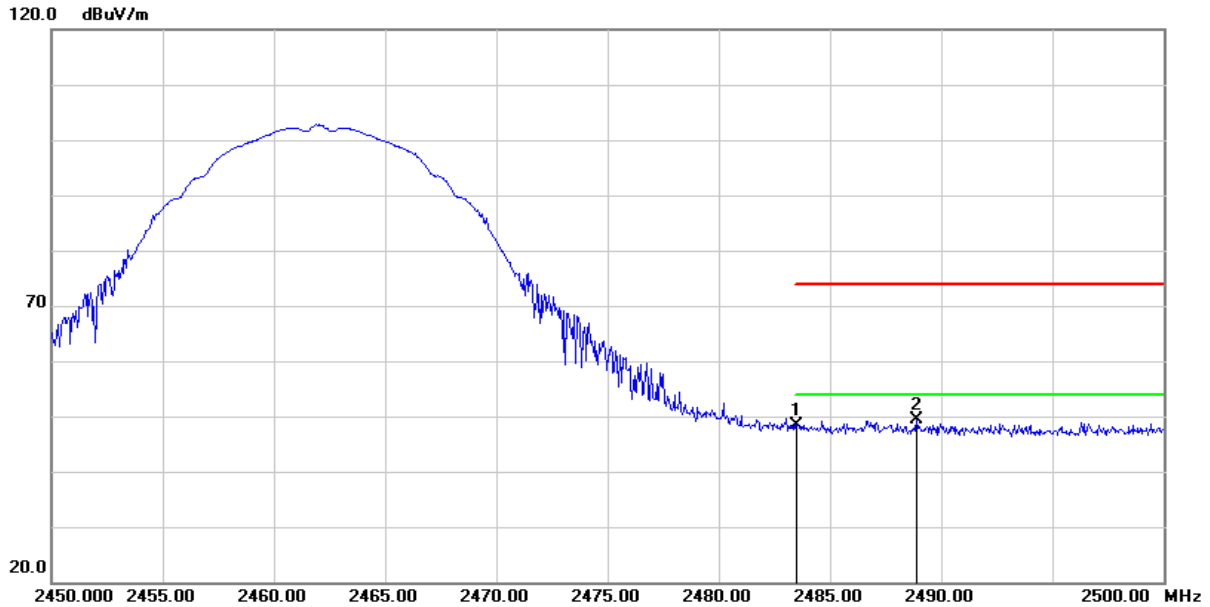

No.	Frequency (MHz)	Reading (dBuV/m)	Correct Factor (dB/m)	Result (dBuV/m)	Limit (dBuV/m)	Margin (dB)	Remark
1	2483.500	54.21	-5.81	48.40	74.00	-25.60	peak
2	2488.900	55.07	-5.80	49.27	74.00	-24.73	peak

Remark :

1. Correction Factor = Antenna factor + Cable loss – Amplifier gain
2. Result Value = Reading Level + Correct Factor
3. Margin Level = Result Value – Limit Value
4. The other emission levels were very low against the limit

Test Mode :	Transmit(802.11b)	Test Date :	2024/07/27
Test Channel :	CH11(2462MHz)	Temperature :	25.8 °C
Polarization :	Vertical	Relative Humidity :	62 %

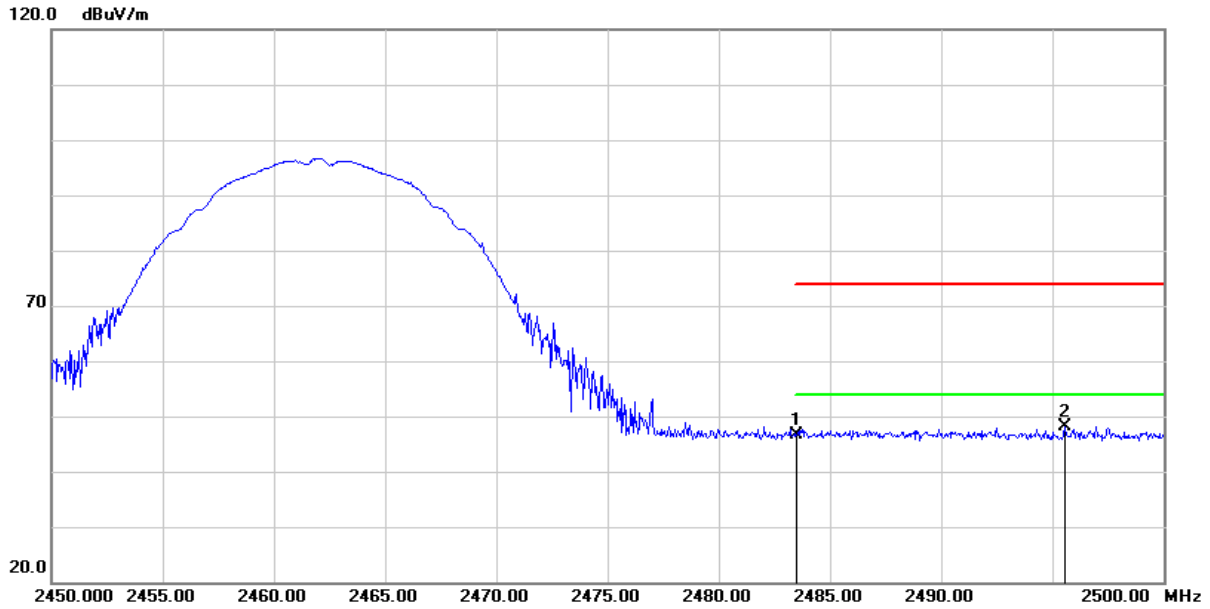

No.	Frequency (MHz)	Reading (dBuV/m)	Correct Factor (dB/m)	Result (dBuV/m)	Limit (dBuV/m)	Margin (dB)	Remark
1	2483.500	52.48	-5.81	46.67	74.00	-27.33	peak
2	2495.550	53.91	-5.79	48.12	74.00	-25.88	peak

Remark :

1. Correction Factor = Antenna factor + Cable loss – Amplifier gain
2. Result Value = Reading Level + Correct Factor
3. Margin Level = Result Value – Limit Value
4. The other emission levels were very low against the limit

Test Mode :	Transmit(802.11g)	Test Date :	2024/07/26
Test Channel :	CH01(2412MHz)	Temperature :	25.8 °C
Polarization :	Horizontal	Relative Humidity :	62 %

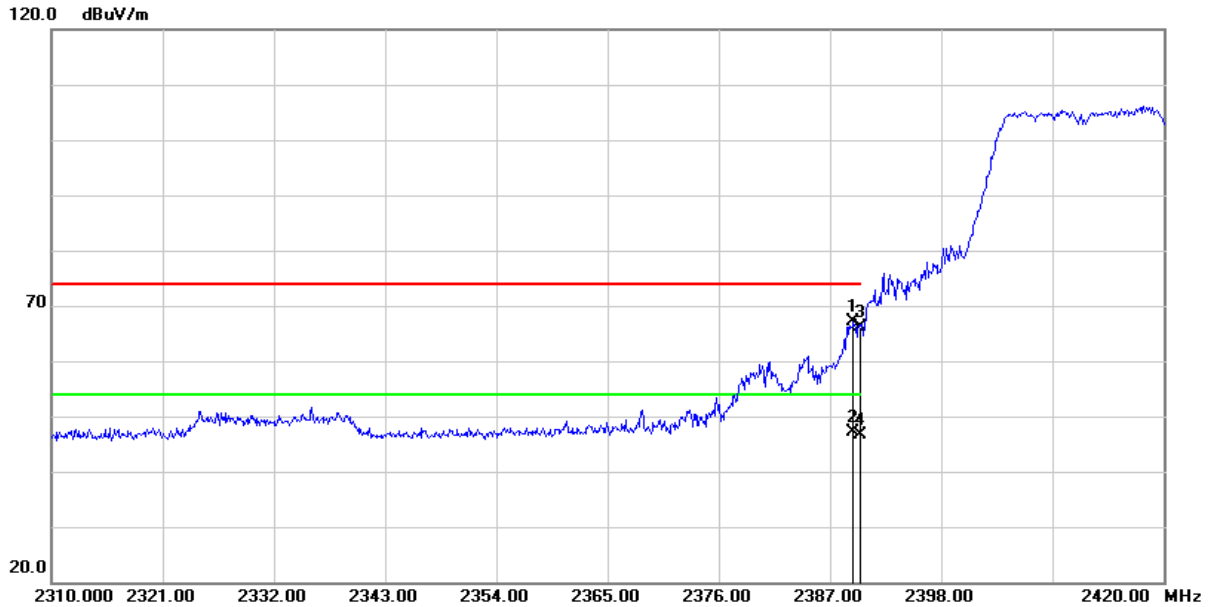

No.	Frequency (MHz)	Reading (dBuV/m)	Correct Factor (dB/m)	Result (dBuV/m)	Limit (dBuV/m)	Margin (dB)	Remark
1	2389.310	72.80	-5.70	67.10	74.00	-6.90	peak
2	2389.310	52.78	-5.70	47.08	54.00	-6.92	AVG
3	2390.000	71.70	-5.69	66.01	74.00	-7.99	peak
4	2390.000	52.29	-5.69	46.60	54.00	-7.40	AVG

Remark :

1. Correction Factor = Antenna factor + Cable loss – Amplifier gain
2. Result Value = Reading Level + Correct Factor
3. Margin Level = Result Value – Limit Value
4. The other emission levels were very low against the limit

Test Mode :	Transmit(802.11g)	Test Date :	2024/07/26
Test Channel :	CH01(2412MHz)	Temperature :	25.8 °C
Polarization :	Vertical	Relative Humidity :	62 %

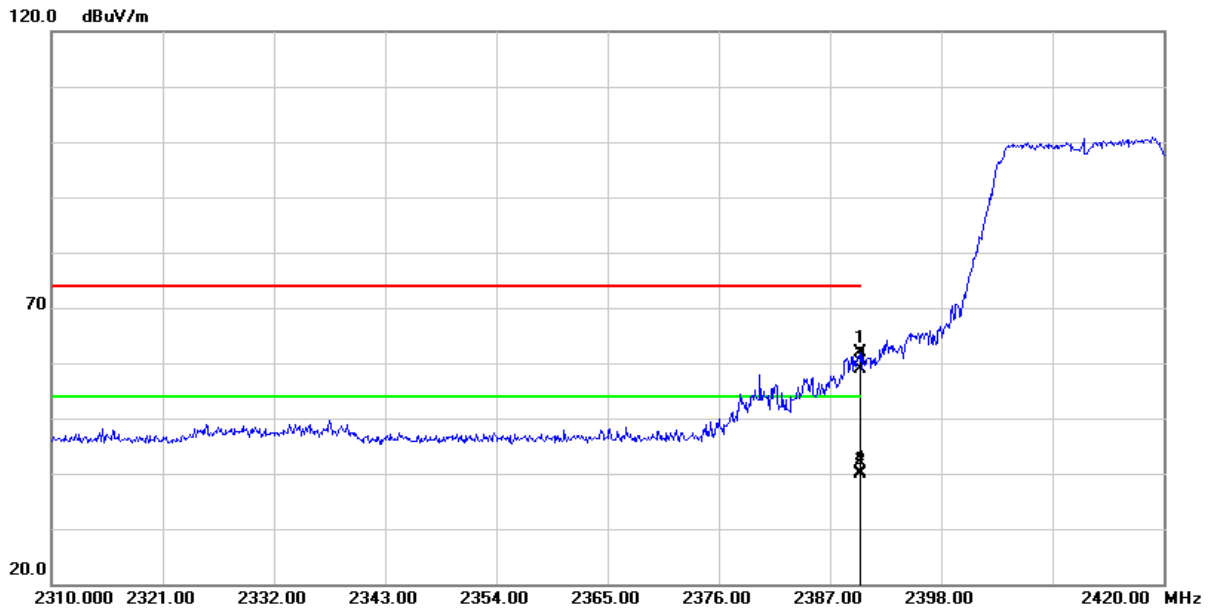

No.	Frequency (MHz)	Reading (dBuV/m)	Correct Factor (dB/m)	Result (dBuV/m)	Limit (dBuV/m)	Margin (dB)	Remark
1	2389.970	67.50	-5.69	61.81	74.00	-12.19	peak
2	2389.970	45.66	-5.69	39.97	54.00	-14.03	AVG
3	2390.000	64.67	-5.69	58.98	74.00	-15.02	peak
4	2390.000	45.70	-5.69	40.01	54.00	-13.99	AVG

Remark :

1. Correction Factor = Antenna factor + Cable loss – Amplifier gain
2. Result Value = Reading Level + Correct Factor
3. Margin Level = Result Value – Limit Value
4. The other emission levels were very low against the limit

Test Mode :	Transmit(802.11g)	Test Date :	2024/07/26
Test Channel :	CH11(2462MHz)	Temperature :	25.8 °C
Polarization :	Horizontal	Relative Humidity :	62 %

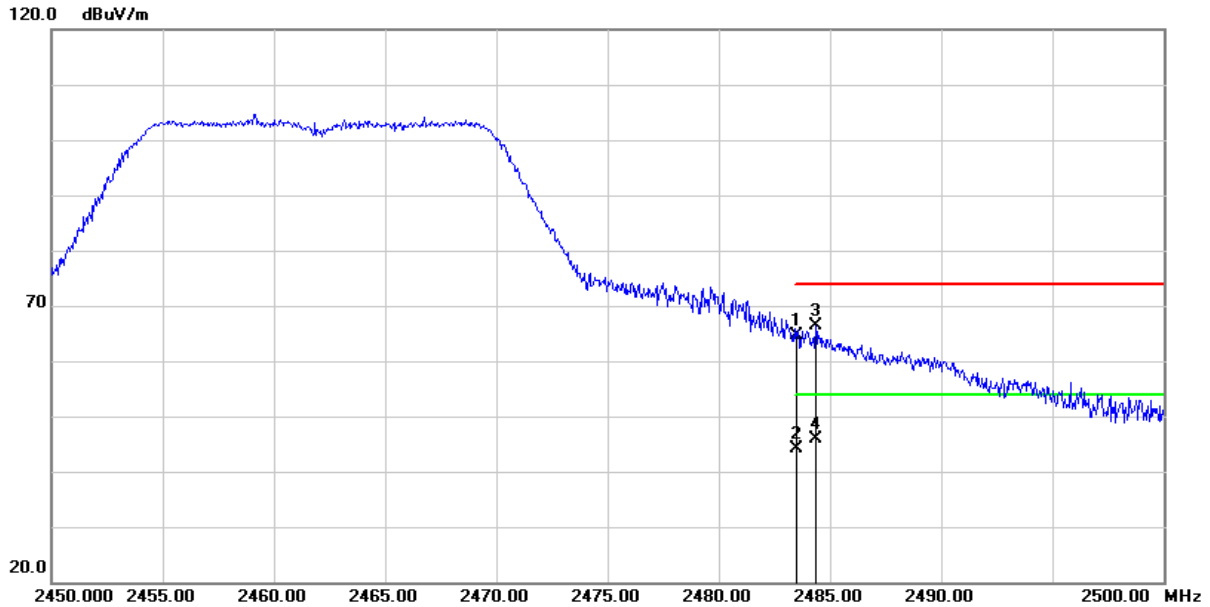

No.	Frequency (MHz)	Reading (dBuV/m)	Correct Factor (dB/m)	Result (dBuV/m)	Limit (dBuV/m)	Margin (dB)	Remark
1	2483.500	70.45	-5.81	64.64	74.00	-9.36	peak
2	2483.500	49.90	-5.81	44.09	54.00	-9.91	AVG
3	2484.350	72.15	-5.80	66.35	74.00	-7.65	peak
4	2484.350	51.77	-5.80	45.97	54.00	-8.03	AVG

Remark :

1. Correction Factor = Antenna factor + Cable loss – Amplifier gain
2. Result Value = Reading Level + Correct Factor
3. Margin Level = Result Value – Limit Value
4. The other emission levels were very low against the limit

Test Mode :	Transmit(802.11g)	Test Date :	2024/07/26
Test Channel :	CH11(2462MHz)	Temperature :	25.8 °C
Polarization :	Vertical	Relative Humidity :	62 %

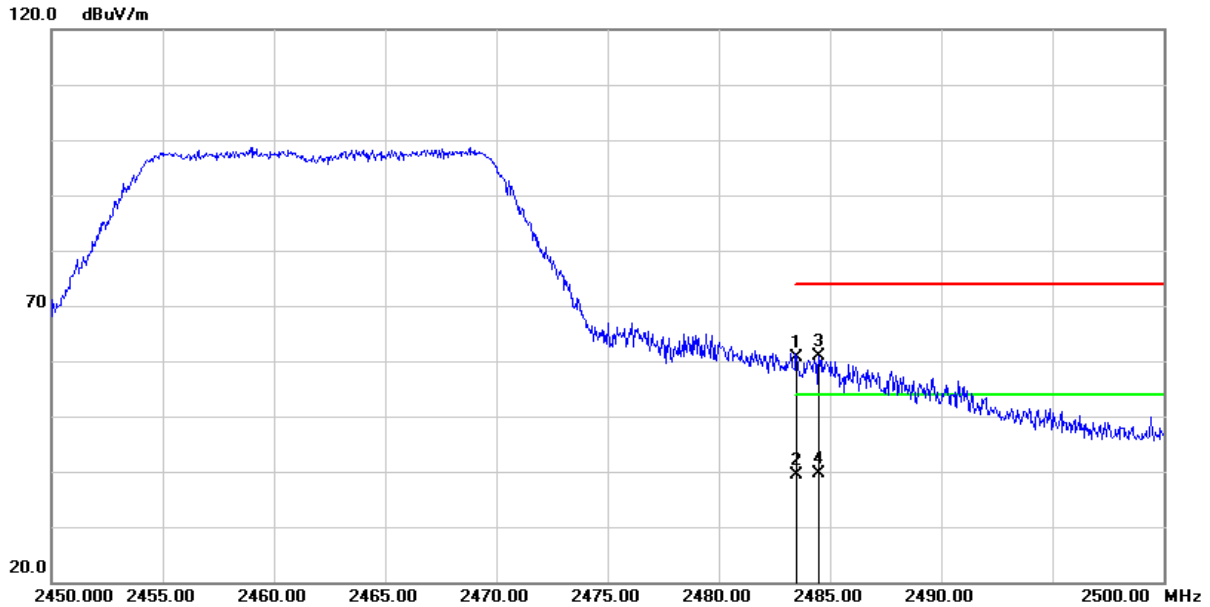

No.	Frequency (MHz)	Reading (dBuV/m)	Correct Factor (dB/m)	Result (dBuV/m)	Limit (dBuV/m)	Margin (dB)	Remark
1	2483.500	66.54	-5.81	60.73	74.00	-13.27	peak
2	2483.500	45.12	-5.81	39.31	54.00	-14.69	AVG
3	2484.500	66.66	-5.80	60.86	74.00	-13.14	peak
4	2484.500	45.32	-5.80	39.52	54.00	-14.48	AVG

Remark :

1. Correction Factor = Antenna factor + Cable loss – Amplifier gain
2. Result Value = Reading Level + Correct Factor
3. Margin Level = Result Value – Limit Value
4. The other emission levels were very low against the limit

Test Mode :	Transmit(802.11n HT20)	Test Date :	2024/07/26
Test Channel :	CH01(2412MHz)	Temperature :	25.8 °C
Polarization :	Horizontal	Relative Humidity :	62 %

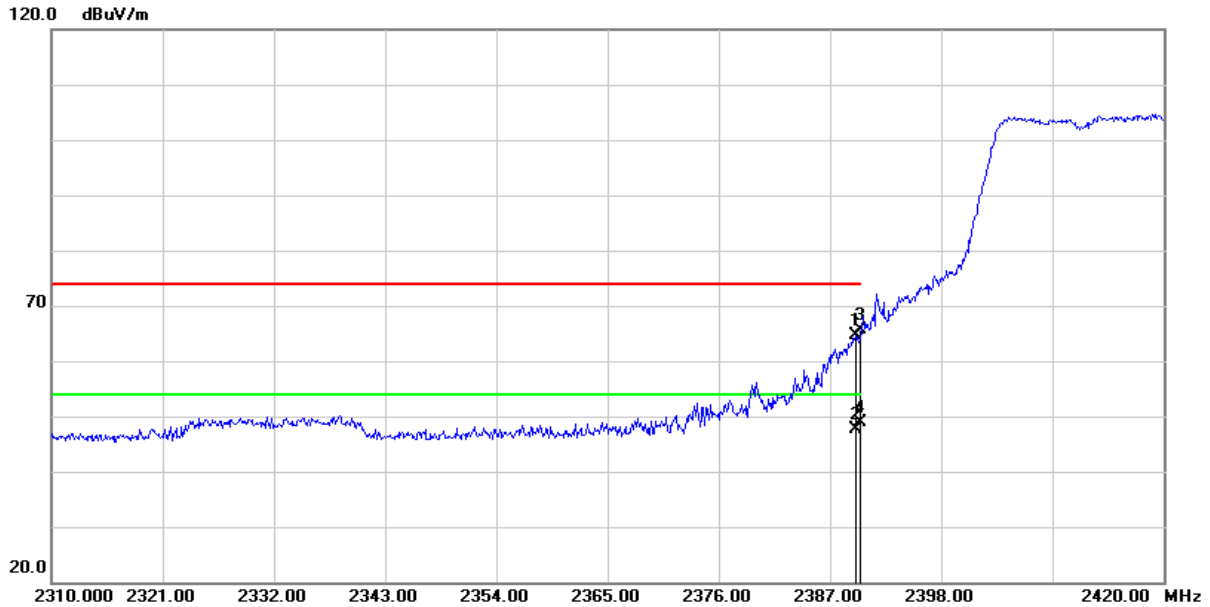

No.	Frequency (MHz)	Reading (dBuV/m)	Correct Factor (dB/m)	Result (dBuV/m)	Limit (dBuV/m)	Margin (dB)	Remark
1	2389.530	70.43	-5.69	64.74	74.00	-9.26	peak
2	2389.530	53.44	-5.69	47.75	54.00	-6.25	AVG
3	2390.000	71.41	-5.69	65.72	74.00	-8.28	peak
4	2390.000	54.65	-5.69	48.96	54.00	-5.04	AVG

Remark :

1. Correction Factor = Antenna factor + Cable loss – Amplifier gain
2. Result Value = Reading Level + Correct Factor
3. Margin Level = Result Value – Limit Value
4. The other emission levels were very low against the limit

Test Mode :	Transmit(802.11n HT20)	Test Date :	2024/07/26
Test Channel :	CH01(2412MHz)	Temperature :	25.8 °C
Polarization :	Vertical	Relative Humidity :	62 %

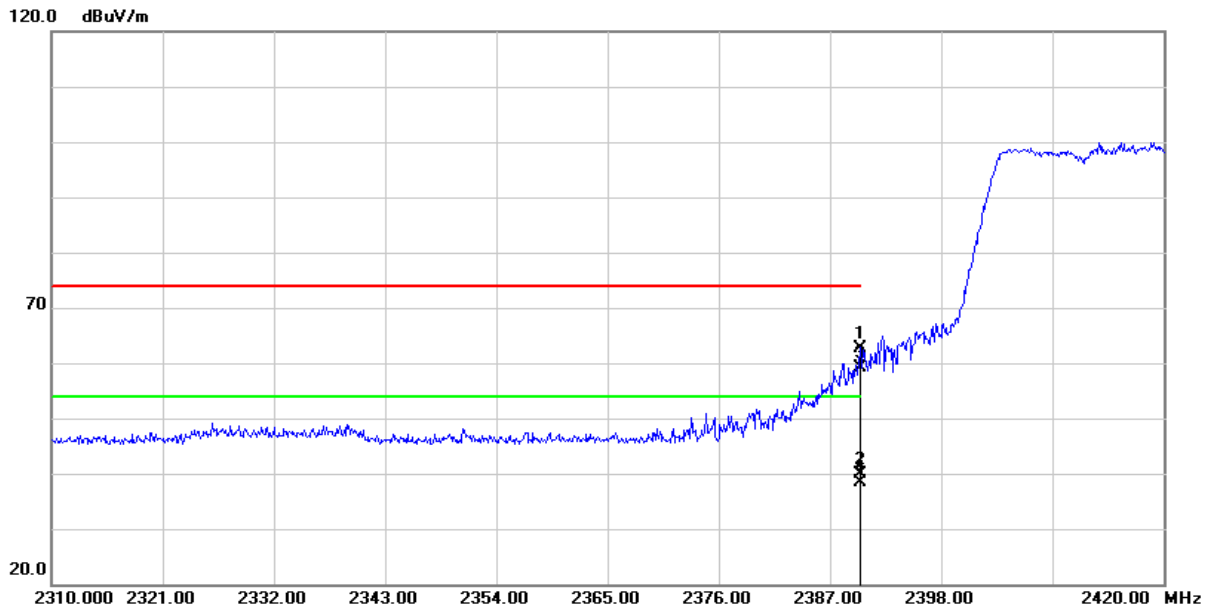

No.	Frequency (MHz)	Reading (dBuV/m)	Correct Factor (dB/m)	Result (dBuV/m)	Limit (dBuV/m)	Margin (dB)	Remark
1	2389.970	68.44	-5.69	62.75	74.00	-11.25	peak
2	2389.970	45.48	-5.69	39.79	54.00	-14.21	AVG
3	2390.000	64.77	-5.69	59.08	74.00	-14.92	peak
4	2390.000	44.13	-5.69	38.44	54.00	-15.56	AVG

Remark :

1. Correction Factor = Antenna factor + Cable loss – Amplifier gain
2. Result Value = Reading Level + Correct Factor
3. Margin Level = Result Value – Limit Value
4. The other emission levels were very low against the limit

Test Mode :	Transmit(802.11n HT20)	Test Date :	2024/07/26
Test Channel :	CH11(2462MHz)	Temperature :	25.8 °C
Polarization :	Horizontal	Relative Humidity :	62 %

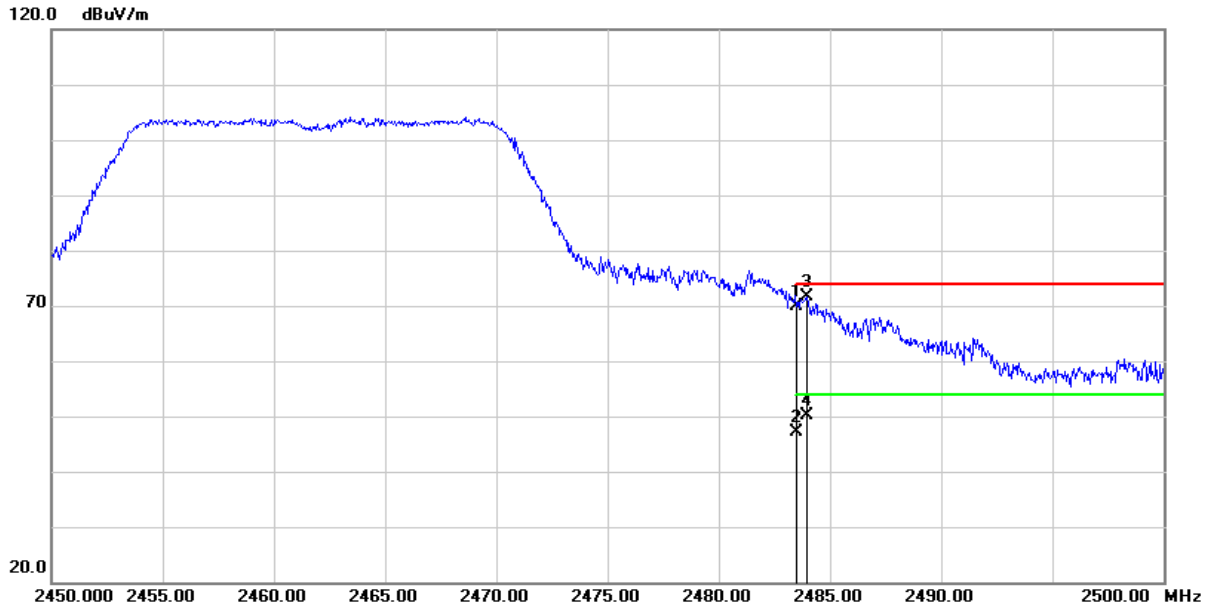

No.	Frequency (MHz)	Reading (dBuV/m)	Correct Factor (dB/m)	Result (dBuV/m)	Limit (dBuV/m)	Margin (dB)	Remark
1	2483.500	75.79	-5.81	69.98	74.00	-4.02	peak
2	2483.500	52.82	-5.81	47.01	54.00	-6.99	AVG
3	2483.950	77.36	-5.81	71.55	74.00	-2.45	peak
4	2483.950	56.02	-5.81	50.21	54.00	-3.79	AVG

Remark :

1. Correction Factor = Antenna factor + Cable loss – Amplifier gain
2. Result Value = Reading Level + Correct Factor
3. Margin Level = Result Value – Limit Value
4. The other emission levels were very low against the limit

Test Mode :	Transmit(802.11n HT20)	Test Date :	2024/07/26
Test Channel :	CH11(2462MHz)	Temperature :	25.8 °C
Polarization :	Vertical	Relative Humidity :	62 %

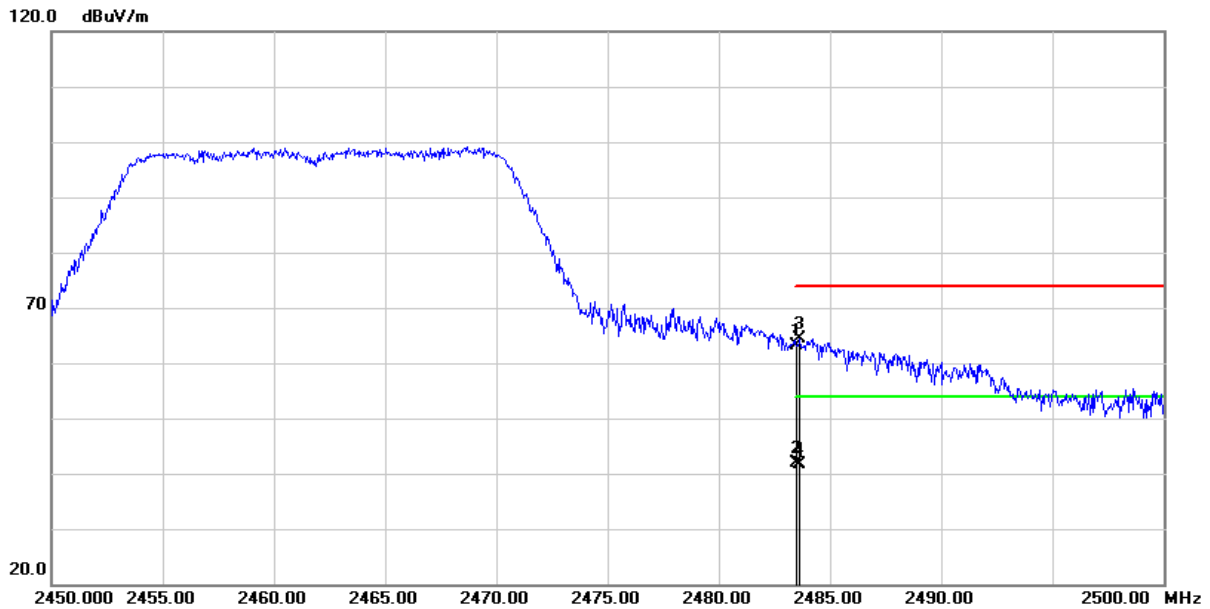

No.	Frequency (MHz)	Reading (dBuV/m)	Correct Factor (dB/m)	Result (dBuV/m)	Limit (dBuV/m)	Margin (dB)	Remark
1	2483.500	68.94	-5.81	63.13	74.00	-10.87	peak
2	2483.500	47.61	-5.81	41.80	54.00	-12.20	AVG
3	2483.650	70.07	-5.81	64.26	74.00	-9.74	peak
4	2483.650	47.35	-5.81	41.54	54.00	-12.46	AVG

Remark :

1. Correction Factor = Antenna factor + Cable loss – Amplifier gain
2. Result Value = Reading Level + Correct Factor
3. Margin Level = Result Value – Limit Value
4. The other emission levels were very low against the limit

2.6.6 Test Result of Radiated Spurious Emission Measurement

- (1) The radiation measurement frequency is 9kHz ~ 30MHz. The interference value of this frequency range is less than the limit value of 20 dB. It is considered that the background noise value is not recorded.
- (2) The following table shows the radiation measurement frequency from 30MHz to 26.5GHz, pre-scanning in the X, Y and Z axes. The worst case (X-axis) is documented in this report.

Test Frequency	
RF	802.11b / 802.11g / 802.11n HT20
Tx	CH01 (2412MHz) CH06 (2437MHz) CH11 (2462MHz)

Above 1GHz Data

Test Mode :	Transmit(802.11b)	Test Date :	2024/07/26
Test Channel :	CH01(2412MHz)	Temperature :	25.8 °C
Polarization :	Horizontal	Relative Humidity :	62 %

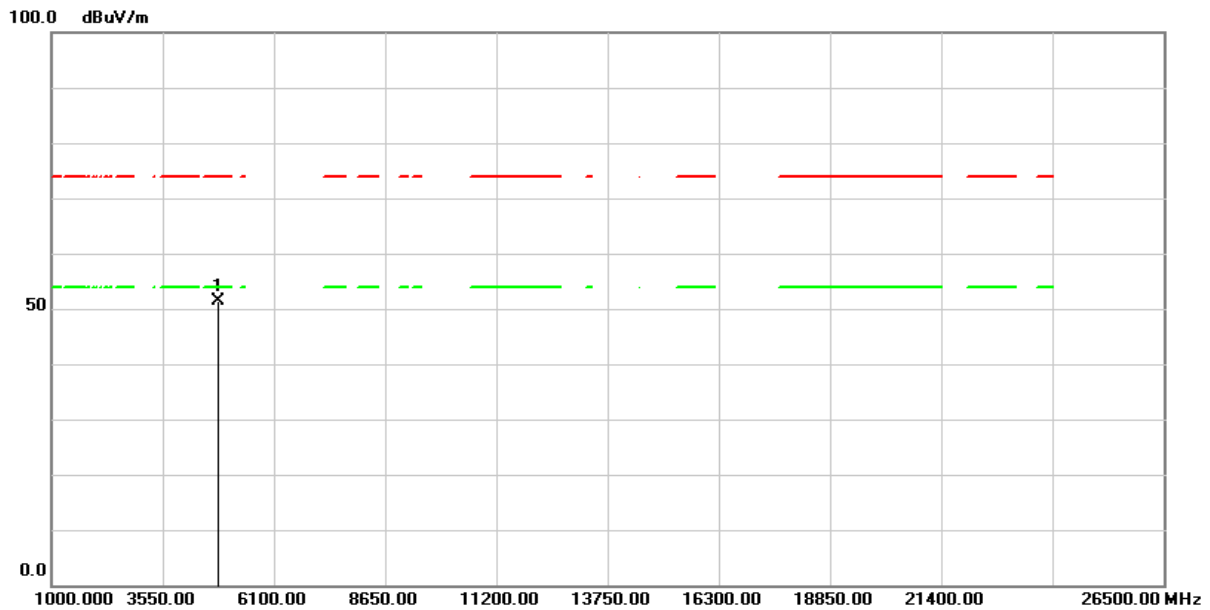

No.	Frequency (MHz)	Reading (dBuV/m)	Correct Factor (dB/m)	Result (dBuV/m)	Limit (dBuV/m)	Margin (dB)	Remark
1	4824.000	70.30	-18.98	51.32	74.00	-22.68	peak

Remark :

1. Correction Factor = Antenna factor + Cable loss – Amplifier gain
2. Result Value = Reading Level + Correct Factor
3. Margin Level = Result Value – Limit Value
4. The other emission levels were very low against the limit

Test Mode :	Transmit(802.11b)	Test Date :	2024/07/26
Test Channel :	CH01(2412MHz)	Temperature :	25.8 °C
Polarization :	Vertical	Relative Humidity :	62 %

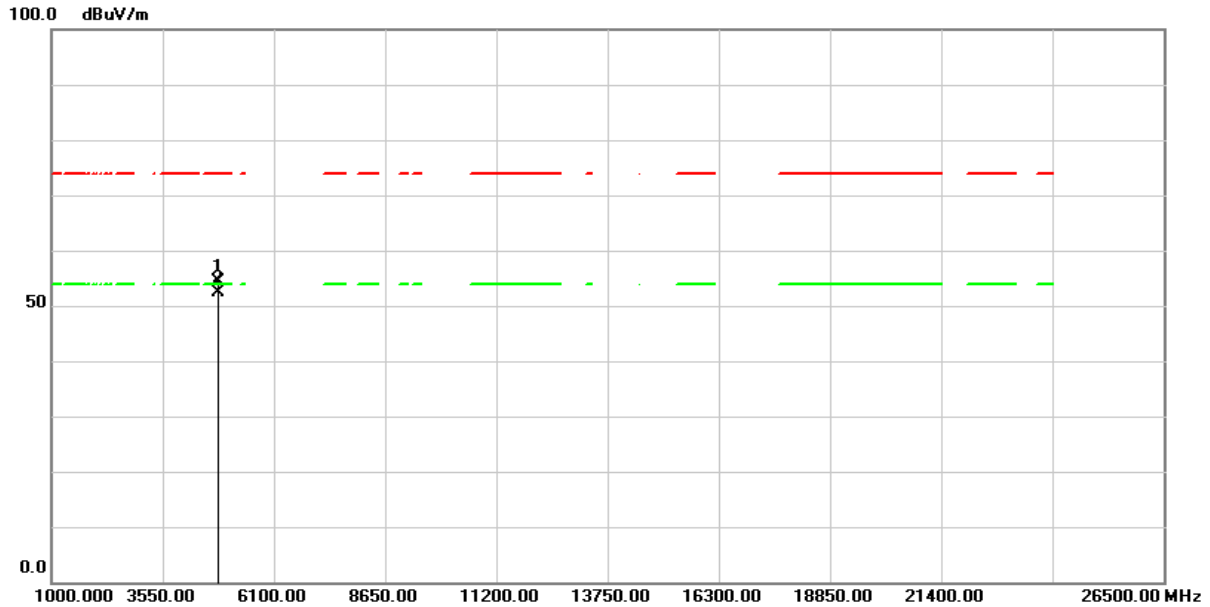

No.	Frequency (MHz)	Reading (dBuV/m)	Correct Factor (dB/m)	Result (dBuV/m)	Limit (dBuV/m)	Margin (dB)	Remark
1	4824.000	73.30	-18.98	54.32	74.00	-19.68	peak
2	4824.000	71.44	-18.98	52.46	54.00	-1.54	AVG

Remark :

1. Correction Factor = Antenna factor + Cable loss – Amplifier gain
2. Result Value = Reading Level + Correct Factor
3. Margin Level = Result Value – Limit Value
4. The other emission levels were very low against the limit

Test Mode :	Transmit(802.11b)	Test Date :	2024/07/26
Test Channel :	CH06(2437MHz)	Temperature :	25.8 °C
Polarization :	Horizontal	Relative Humidity :	62 %

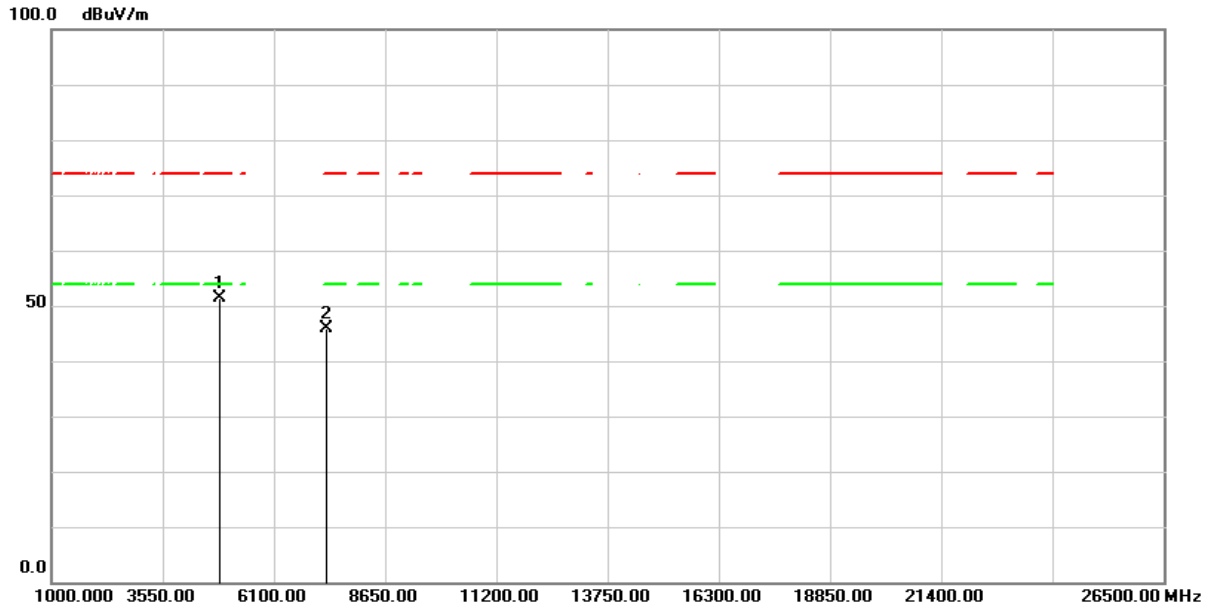

No.	Frequency (MHz)	Reading (dBuV/m)	Correct Factor (dB/m)	Result (dBuV/m)	Limit (dBuV/m)	Margin (dB)	Remark
1	4874.000	70.29	-19.00	51.29	74.00	-22.71	peak
2	7311.000	58.46	-12.53	45.93	74.00	-28.07	peak

Remark :

1. Correction Factor = Antenna factor + Cable loss – Amplifier gain
2. Result Value = Reading Level + Correct Factor
3. Margin Level = Result Value – Limit Value
4. The other emission levels were very low against the limit

Test Mode :	Transmit(802.11b)	Test Date :	2024/07/26
Test Channel :	CH06(2437MHz)	Temperature :	25.8 °C
Polarization :	Vertical	Relative Humidity :	62 %

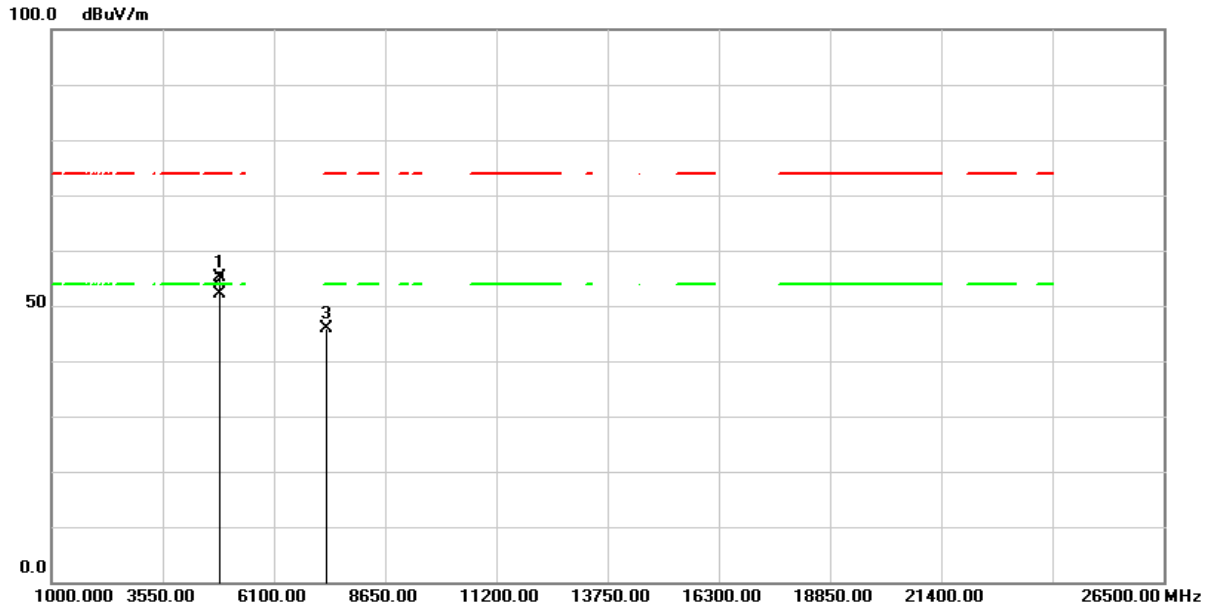

No.	Frequency (MHz)	Reading (dBuV/m)	Correct Factor (dB/m)	Result (dBuV/m)	Limit (dBuV/m)	Margin (dB)	Remark
1	4874.000	74.05	-19.00	55.05	74.00	-18.95	peak
2	4874.000	71.25	-19.00	52.25	54.00	-1.75	AVG
3	7311.000	58.30	-12.53	45.77	74.00	-28.23	peak

Remark :

1. Correction Factor = Antenna factor + Cable loss – Amplifier gain
2. Result Value = Reading Level + Correct Factor
3. Margin Level = Result Value – Limit Value
4. The other emission levels were very low against the limit

Test Mode :	Transmit(802.11b)	Test Date :	2024/07/26
Test Channel :	CH11(2462MHz)	Temperature :	25.8 °C
Polarization :	Horizontal	Relative Humidity :	62 %

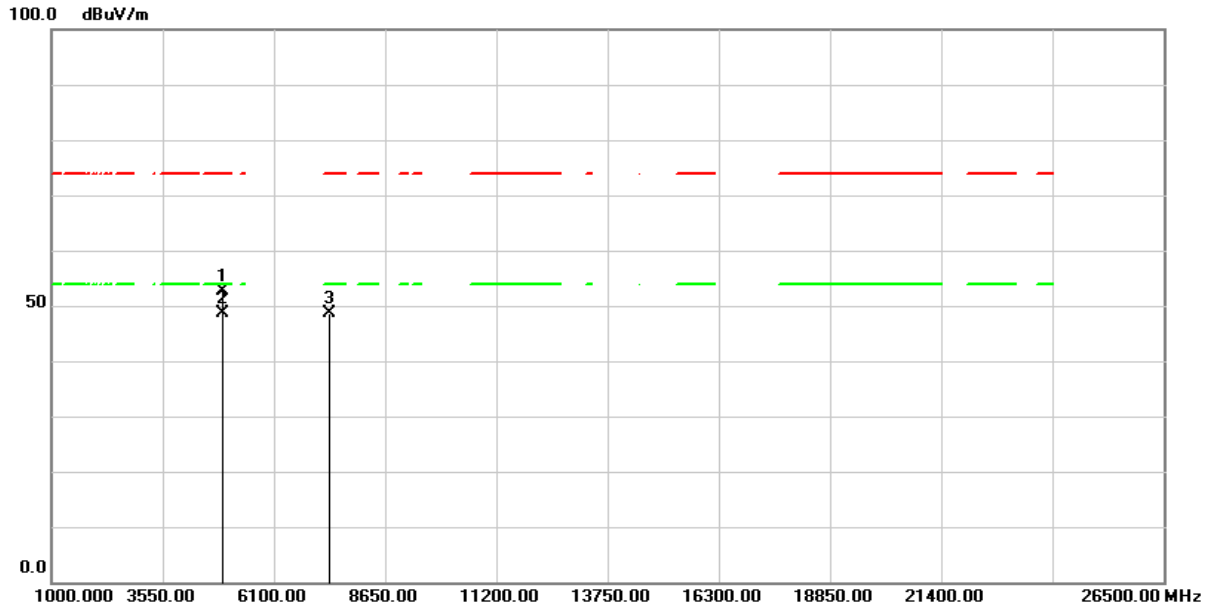

No.	Frequency (MHz)	Reading (dBuV/m)	Correct Factor (dB/m)	Result (dBuV/m)	Limit (dBuV/m)	Margin (dB)	Remark
1	4924.000	71.68	-19.01	52.67	74.00	-21.33	peak
2	4924.000	67.53	-19.01	48.52	54.00	-5.48	AVG
3	7386.000	61.02	-12.39	48.63	74.00	-25.37	peak

Remark :

1. Correction Factor = Antenna factor + Cable loss – Amplifier gain
2. Result Value = Reading Level + Correct Factor
3. Margin Level = Result Value – Limit Value
4. The other emission levels were very low against the limit

Test Mode :	Transmit(802.11b)	Test Date :	2024/07/26
Test Channel :	CH11(2462MHz)	Temperature :	25.8 °C
Polarization :	Vertical	Relative Humidity :	62 %

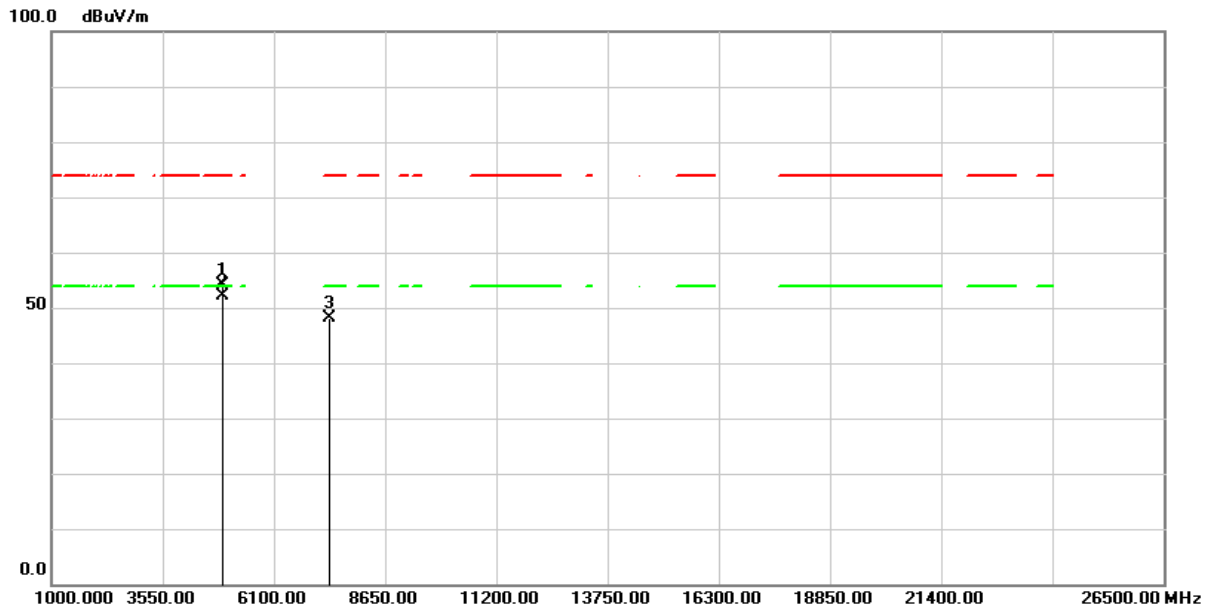

No.	Frequency (MHz)	Reading (dBuV/m)	Correct Factor (dB/m)	Result (dBuV/m)	Limit (dBuV/m)	Margin (dB)	Remark
1	4924.000	73.25	-19.01	54.24	74.00	-19.76	peak
2	4924.000	71.15	-19.01	52.14	54.00	-1.86	AVG
3	7386.000	60.53	-12.39	48.14	74.00	-25.86	peak

Remark :

1. Correction Factor = Antenna factor + Cable loss – Amplifier gain
2. Result Value = Reading Level + Correct Factor
3. Margin Level = Result Value – Limit Value
4. The other emission levels were very low against the limit

Test Mode :	Transmit(802.11g)	Test Date :	2024/07/26
Test Channel :	CH01(2412MHz)	Temperature :	25.8 °C
Polarization :	Horizontal	Relative Humidity :	62 %

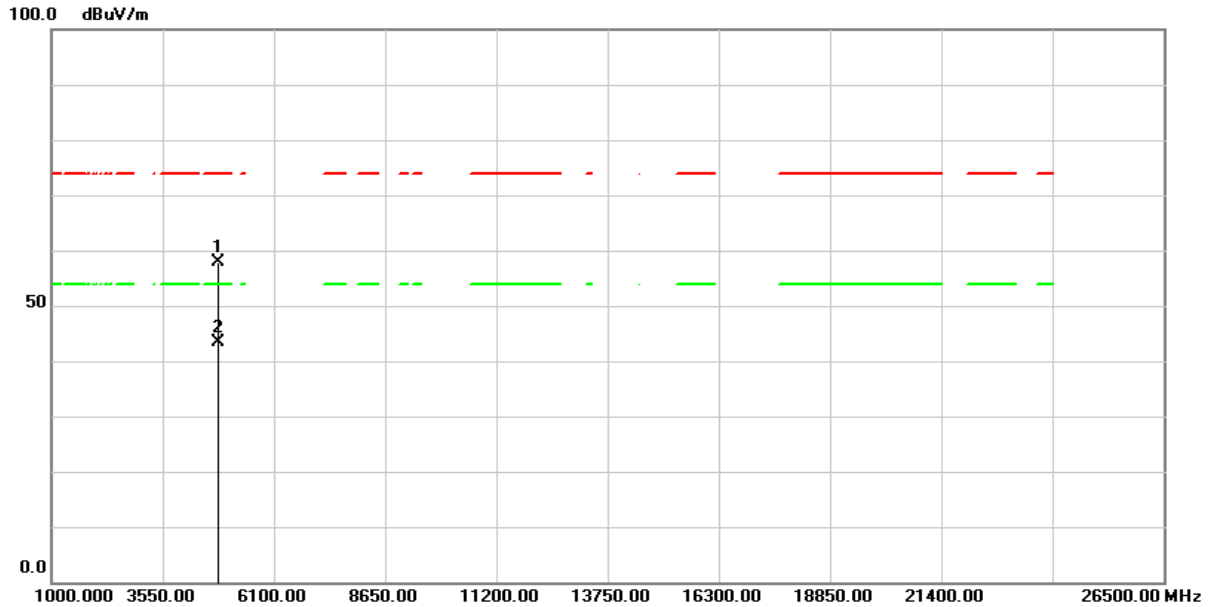

No.	Frequency (MHz)	Reading (dBuV/m)	Correct Factor (dB/m)	Result (dBuV/m)	Limit (dBuV/m)	Margin (dB)	Remark
1	4824.000	76.91	-18.98	57.93	74.00	-16.07	peak
2	4824.000	62.41	-18.98	43.43	54.00	-10.57	AVG

Remark :

1. Correction Factor = Antenna factor + Cable loss – Amplifier gain
2. Result Value = Reading Level + Correct Factor
3. Margin Level = Result Value – Limit Value
4. The other emission levels were very low against the limit

Test Mode :	Transmit(802.11g)	Test Date :	2024/07/26
Test Channel :	CH01(2412MHz)	Temperature :	25.8 °C
Polarization :	Vertical	Relative Humidity :	62 %

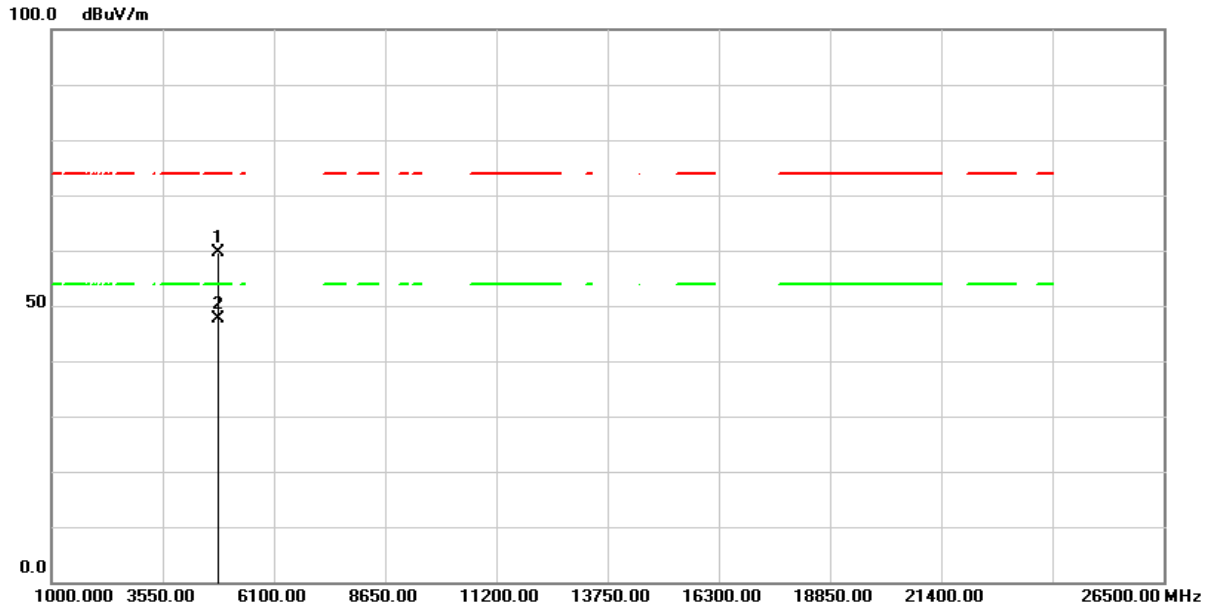

No.	Frequency (MHz)	Reading (dBuV/m)	Correct Factor (dB/m)	Result (dBuV/m)	Limit (dBuV/m)	Margin (dB)	Remark
1	4824.000	78.54	-18.98	59.56	74.00	-14.44	peak
2	4824.000	66.61	-18.98	47.63	54.00	-6.37	AVG

Remark :

1. Correction Factor = Antenna factor + Cable loss – Amplifier gain
2. Result Value = Reading Level + Correct Factor
3. Margin Level = Result Value – Limit Value
4. The other emission levels were very low against the limit

Test Mode :	Transmit(802.11g)	Test Date :	2024/07/26
Test Channel :	CH06(2437MHz)	Temperature :	25.8 °C
Polarization :	Horizontal	Relative Humidity :	62 %

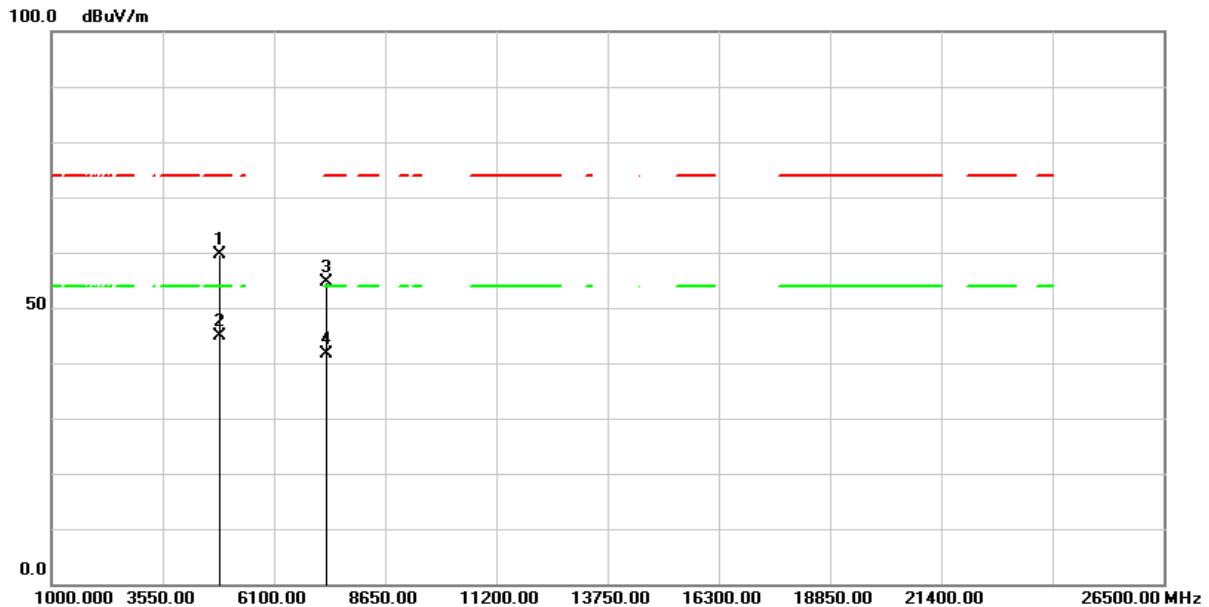

No.	Frequency (MHz)	Reading (dBuV/m)	Correct Factor (dB/m)	Result (dBuV/m)	Limit (dBuV/m)	Margin (dB)	Remark
1	4874.000	78.60	-19.00	59.60	74.00	-14.40	peak
2	4874.000	63.80	-19.00	44.80	54.00	-9.20	AVG
3	7311.000	67.14	-12.53	54.61	74.00	-19.39	peak
4	7311.000	54.22	-12.53	41.69	54.00	-12.31	AVG

Remark :

1. Correction Factor = Antenna factor + Cable loss – Amplifier gain
2. Result Value = Reading Level + Correct Factor
3. Margin Level = Result Value – Limit Value
4. The other emission levels were very low against the limit

Test Mode :	Transmit(802.11g)	Test Date :	2024/07/26
Test Channel :	CH06(2437MHz)	Temperature :	25.8 °C
Polarization :	Vertical	Relative Humidity :	62 %

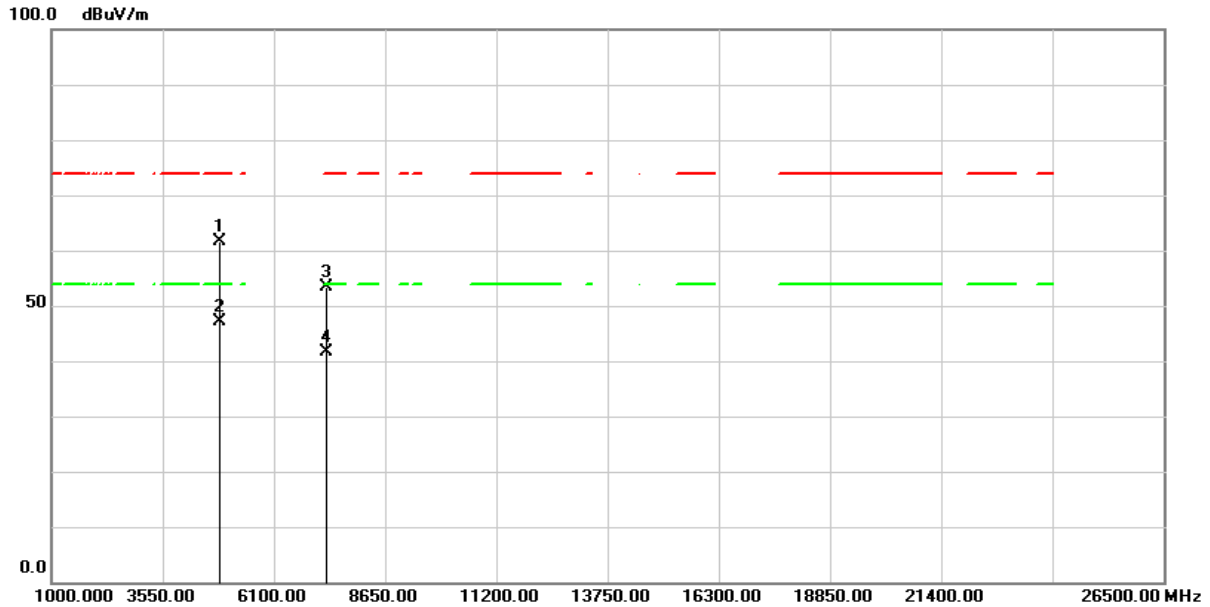

No.	Frequency (MHz)	Reading (dBuV/m)	Correct Factor (dB/m)	Result (dBuV/m)	Limit (dBuV/m)	Margin (dB)	Remark
1	4874.000	80.59	-19.00	61.59	74.00	-12.41	peak
2	4874.000	66.19	-19.00	47.19	54.00	-6.81	AVG
3	7311.000	66.01	-12.53	53.48	74.00	-20.52	peak
4	7311.000	54.18	-12.53	41.65	54.00	-12.35	AVG

Remark :

1. Correction Factor = Antenna factor + Cable loss – Amplifier gain
2. Result Value = Reading Level + Correct Factor
3. Margin Level = Result Value – Limit Value
4. The other emission levels were very low against the limit

Test Mode :	Transmit(802.11g)	Test Date :	2024/07/26
Test Channel :	CH11(2462MHz)	Temperature :	25.8 °C
Polarization :	Horizontal	Relative Humidity :	62 %

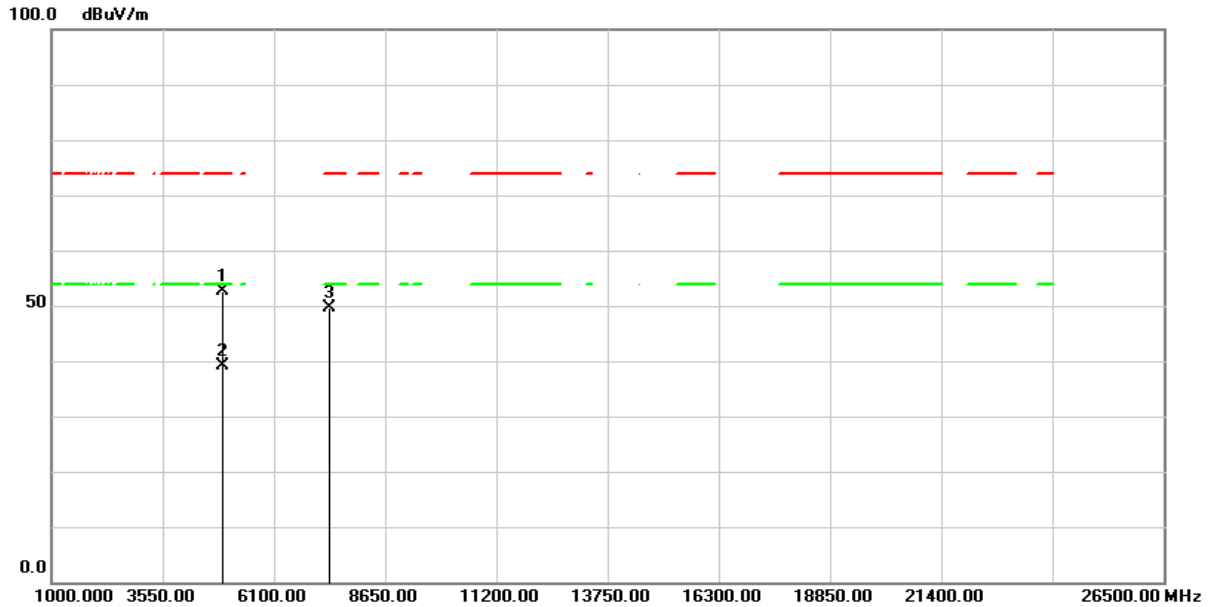

No.	Frequency (MHz)	Reading (dBuV/m)	Correct Factor (dB/m)	Result (dBuV/m)	Limit (dBuV/m)	Margin (dB)	Remark
1	4924.000	71.59	-19.01	52.58	74.00	-21.42	peak
2	4924.000	58.02	-19.01	39.01	54.00	-14.99	AVG
3	7386.000	61.99	-12.39	49.60	74.00	-24.40	peak

Remark :

1. Correction Factor = Antenna factor + Cable loss – Amplifier gain
2. Result Value = Reading Level + Correct Factor
3. Margin Level = Result Value – Limit Value
4. The other emission levels were very low against the limit

Test Mode :	Transmit(802.11g)	Test Date :	2024/07/26
Test Channel :	CH11(2462MHz)	Temperature :	25.8 °C
Polarization :	Vertical	Relative Humidity :	62 %

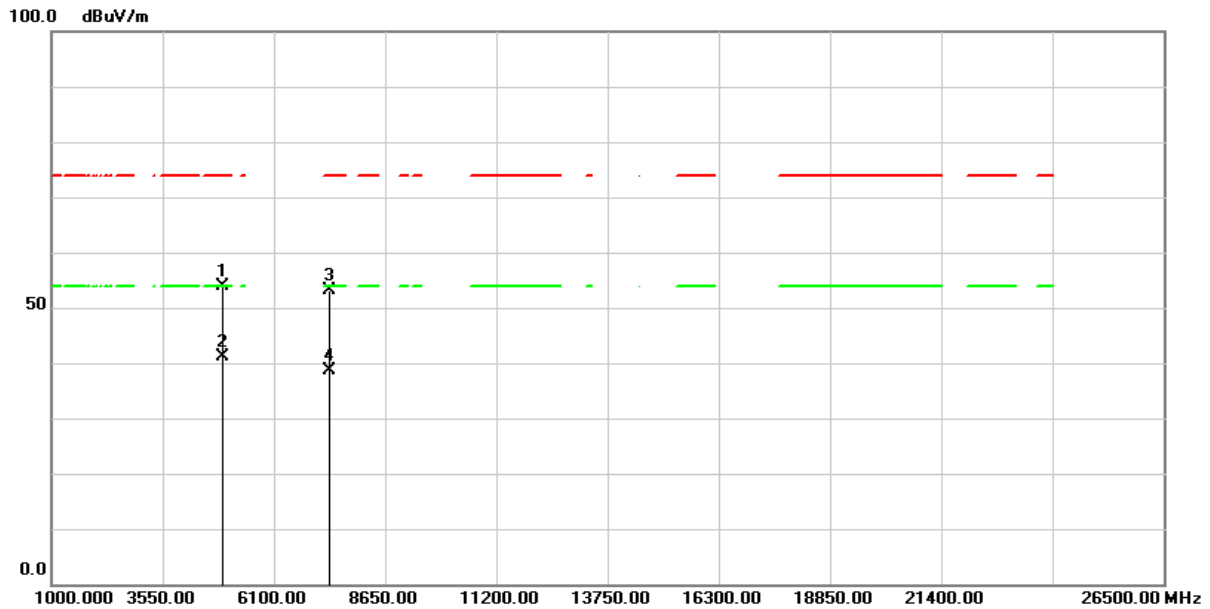

No.	Frequency (MHz)	Reading (dBuV/m)	Correct Factor (dB/m)	Result (dBuV/m)	Limit (dBuV/m)	Margin (dB)	Remark
1	4924.000	73.00	-19.01	53.99	74.00	-20.01	peak
2	4924.000	60.07	-19.01	41.06	54.00	-12.94	AVG
3	7386.000	65.63	-12.39	53.24	74.00	-20.76	peak
4	7386.000	51.06	-12.39	38.67	54.00	-15.33	AVG

Remark :

1. Correction Factor = Antenna factor + Cable loss – Amplifier gain
2. Result Value = Reading Level + Correct Factor
3. Margin Level = Result Value – Limit Value
4. The other emission levels were very low against the limit

Test Mode :	Transmit(802.11n HT20)	Test Date :	2024/07/26
Test Channel :	CH01(2412MHz)	Temperature :	25.8 °C
Polarization :	Horizontal	Relative Humidity :	62 %

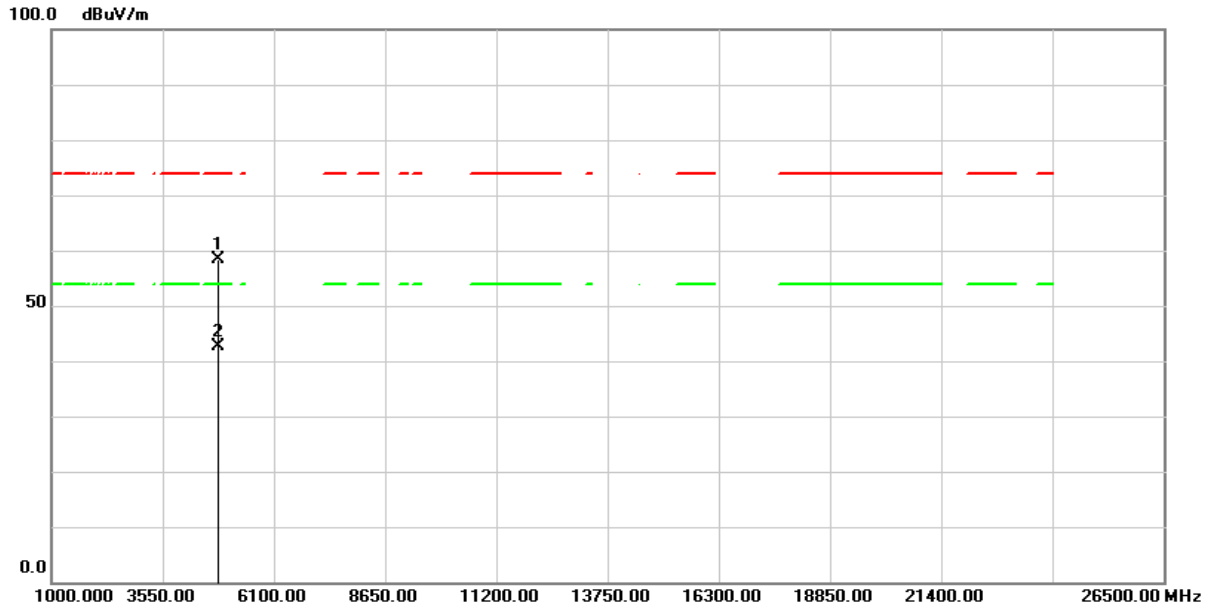

No.	Frequency (MHz)	Reading (dBuV/m)	Correct Factor (dB/m)	Result (dBuV/m)	Limit (dBuV/m)	Margin (dB)	Remark
1	4824.000	77.30	-18.98	58.32	74.00	-15.68	peak
2	4824.000	61.57	-18.98	42.59	54.00	-11.41	AVG

Remark :

1. Correction Factor = Antenna factor + Cable loss – Amplifier gain
2. Result Value = Reading Level + Correct Factor
3. Margin Level = Result Value – Limit Value
4. The other emission levels were very low against the limit

Test Mode :	Transmit(802.11n HT20)	Test Date :	2024/07/26
Test Channel :	CH01(2412MHz)	Temperature :	25.8 °C
Polarization :	Vertical	Relative Humidity :	62 %

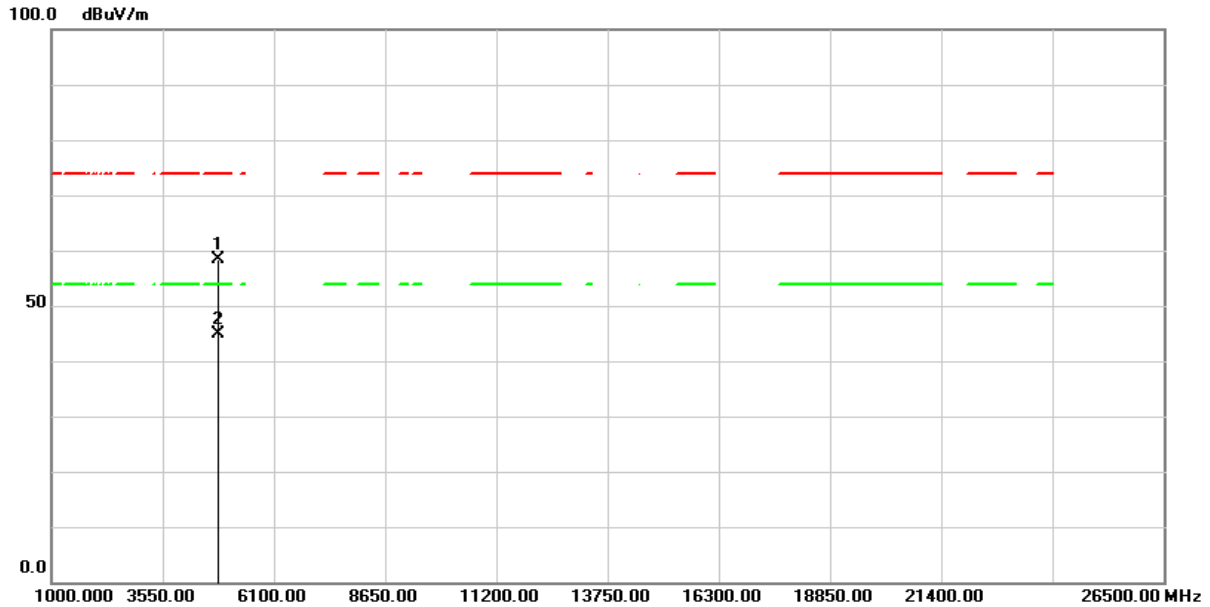

No.	Frequency (MHz)	Reading (dBuV/m)	Correct Factor (dB/m)	Result (dBuV/m)	Limit (dBuV/m)	Margin (dB)	Remark
1	4824.000	77.45	-18.98	58.47	74.00	-15.53	peak
2	4824.000	63.93	-18.98	44.95	54.00	-9.05	AVG

Remark :

1. Correction Factor = Antenna factor + Cable loss – Amplifier gain
2. Result Value = Reading Level + Correct Factor
3. Margin Level = Result Value – Limit Value
4. The other emission levels were very low against the limit

Test Mode :	Transmit(802.11n HT20)	Test Date :	2024/07/26
Test Channel :	CH06(2437MHz)	Temperature :	25.8 °C
Polarization :	Horizontal	Relative Humidity :	62 %

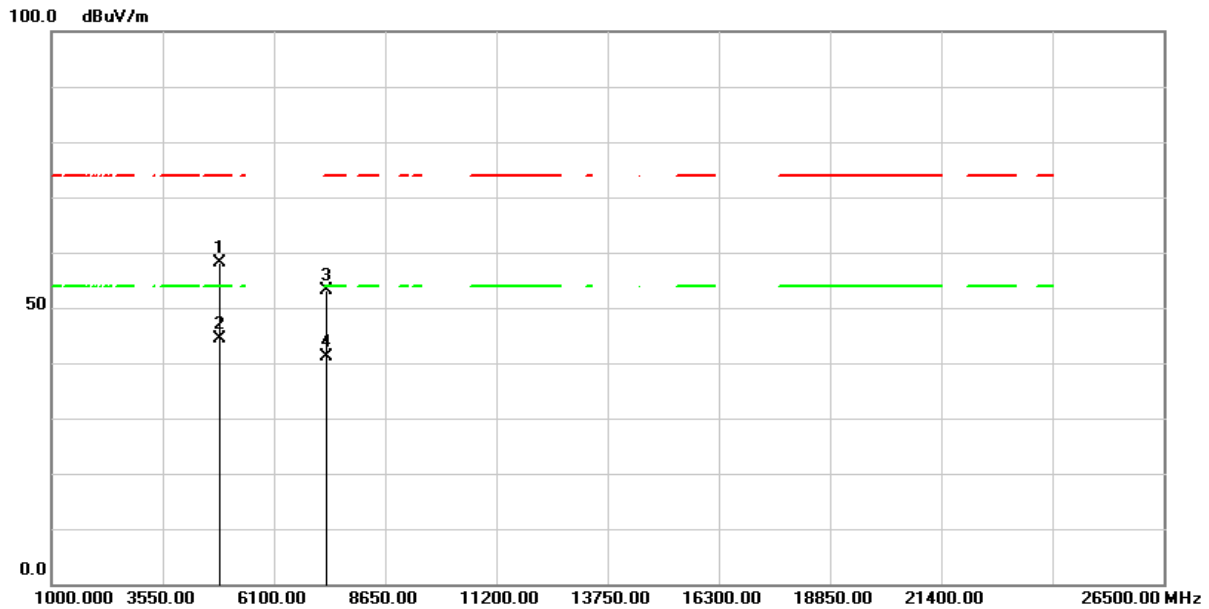

No.	Frequency (MHz)	Reading (dBuV/m)	Correct Factor (dB/m)	Result (dBuV/m)	Limit (dBuV/m)	Margin (dB)	Remark
1	4874.000	77.13	-19.00	58.13	74.00	-15.87	peak
2	4874.000	63.37	-19.00	44.37	54.00	-9.63	AVG
3	7311.000	65.73	-12.53	53.20	74.00	-20.80	peak
4	7311.000	53.60	-12.53	41.07	54.00	-12.93	AVG

Remark :

1. Correction Factor = Antenna factor + Cable loss – Amplifier gain
2. Result Value = Reading Level + Correct Factor
3. Margin Level = Result Value – Limit Value
4. The other emission levels were very low against the limit

Test Mode :	Transmit(802.11n HT20)	Test Date :	2024/07/26
Test Channel :	CH06(2437MHz)	Temperature :	25.8 °C
Polarization :	Vertical	Relative Humidity :	62 %

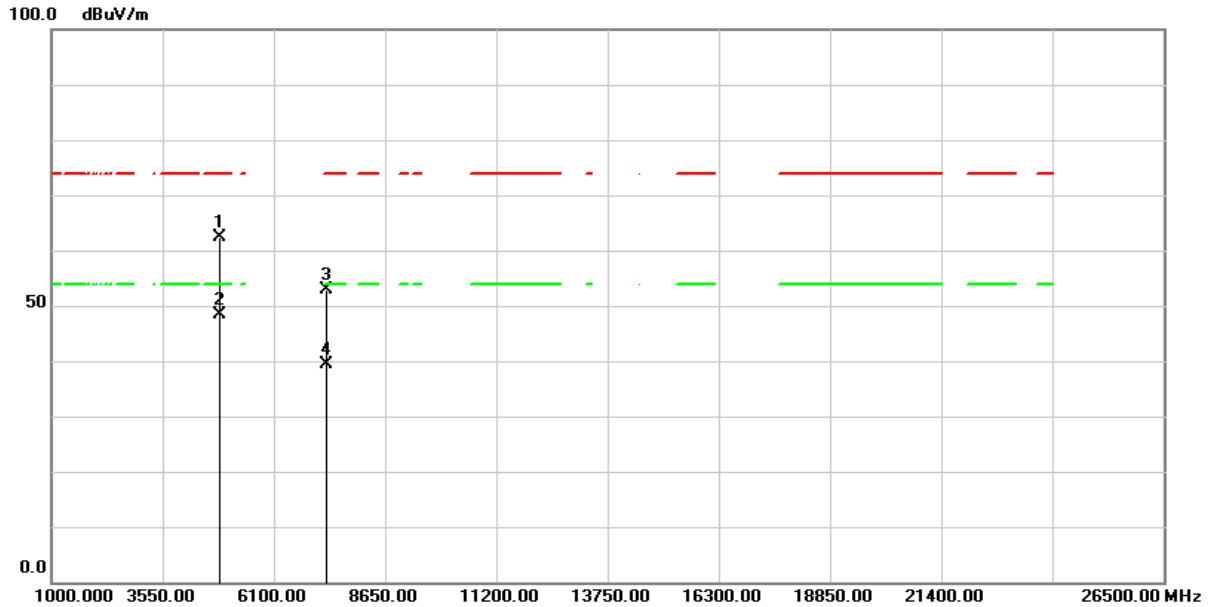

No.	Frequency (MHz)	Reading (dBuV/m)	Correct Factor (dB/m)	Result (dBuV/m)	Limit (dBuV/m)	Margin (dB)	Remark
1	4874.000	81.27	-19.00	62.27	74.00	-11.73	peak
2	4874.000	67.35	-19.00	48.35	54.00	-5.65	AVG
3	7311.000	65.47	-12.53	52.94	74.00	-21.06	peak
4	7311.000	51.98	-12.53	39.45	54.00	-14.55	AVG

Remark :

1. Correction Factor = Antenna factor + Cable loss – Amplifier gain
2. Result Value = Reading Level + Correct Factor
3. Margin Level = Result Value – Limit Value
4. The other emission levels were very low against the limit

Test Mode :	Transmit(802.11n HT20)	Test Date :	2024/07/26
Test Channel :	CH11(2462MHz)	Temperature :	25.8 °C
Polarization :	Horizontal	Relative Humidity :	62 %

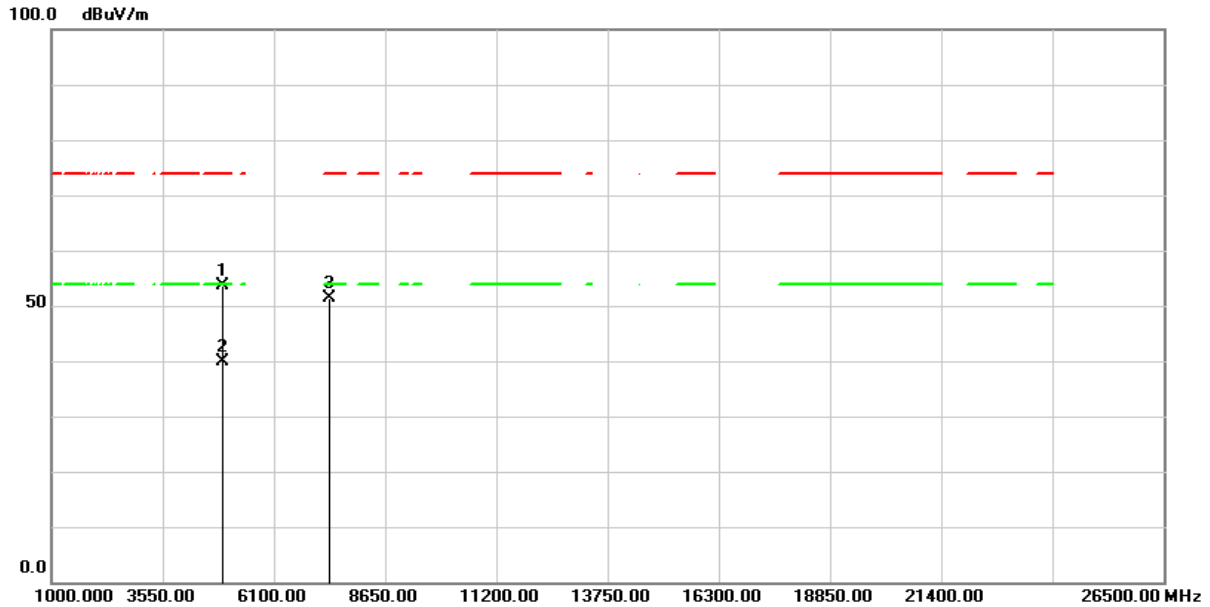

No.	Frequency (MHz)	Reading (dBuV/m)	Correct Factor (dB/m)	Result (dBuV/m)	Limit (dBuV/m)	Margin (dB)	Remark
1	4924.000	72.67	-19.01	53.66	74.00	-20.34	peak
2	4924.000	58.77	-19.01	39.76	54.00	-14.24	AVG
3	7386.000	63.84	-12.39	51.45	74.00	-22.55	peak

Remark :

1. Correction Factor = Antenna factor + Cable loss – Amplifier gain
2. Result Value = Reading Level + Correct Factor
3. Margin Level = Result Value – Limit Value
4. The other emission levels were very low against the limit

Test Mode :	Transmit(802.11n HT20)	Test Date :	2024/07/26
Test Channel :	CH11(2462MHz)	Temperature :	25.8 °C
Polarization :	Vertical	Relative Humidity :	62 %

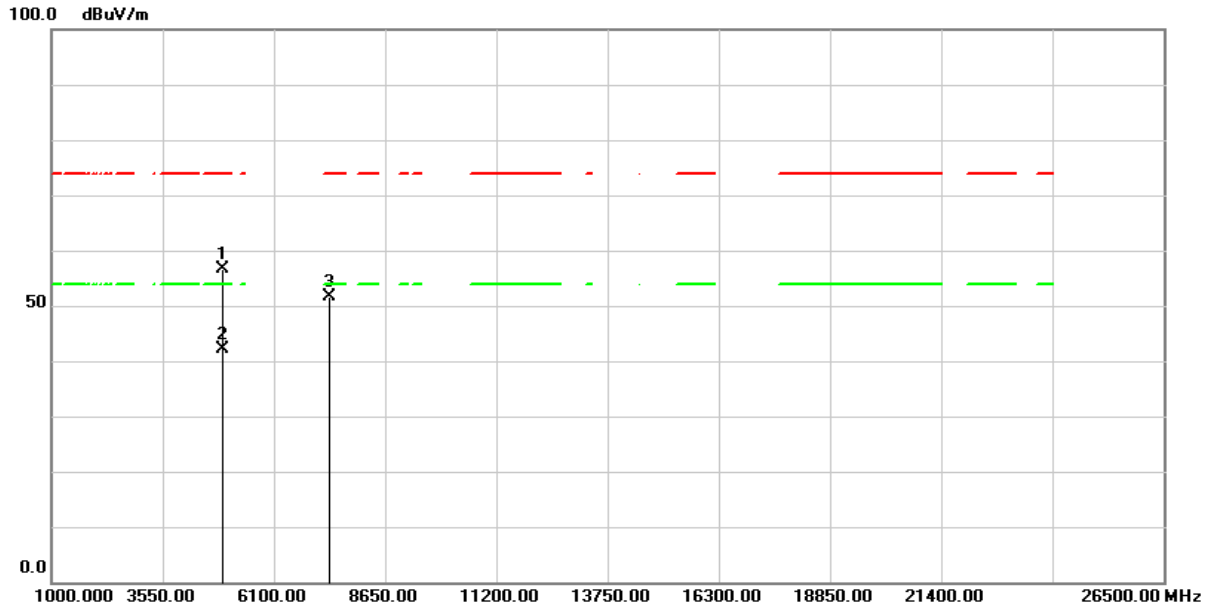

No.	Frequency (MHz)	Reading (dBuV/m)	Correct Factor (dB/m)	Result (dBuV/m)	Limit (dBuV/m)	Margin (dB)	Remark
1	4924.000	75.64	-19.01	56.63	74.00	-17.37	peak
2	4924.000	61.16	-19.01	42.15	54.00	-11.85	AVG
3	7386.000	64.08	-12.39	51.69	74.00	-22.31	peak

Remark :

1. Correction Factor = Antenna factor + Cable loss – Amplifier gain
2. Result Value = Reading Level + Correct Factor
3. Margin Level = Result Value – Limit Value
4. The other emission levels were very low against the limit

Below 1GHz Data

Test Mode :	Transmit(802.11g)	Test Date :	2024/09/23
Test Channel :	CH06(2437MHz)	Temperature :	24.5 °C
Polarization :	Horizontal	Relative Humidity :	54 %

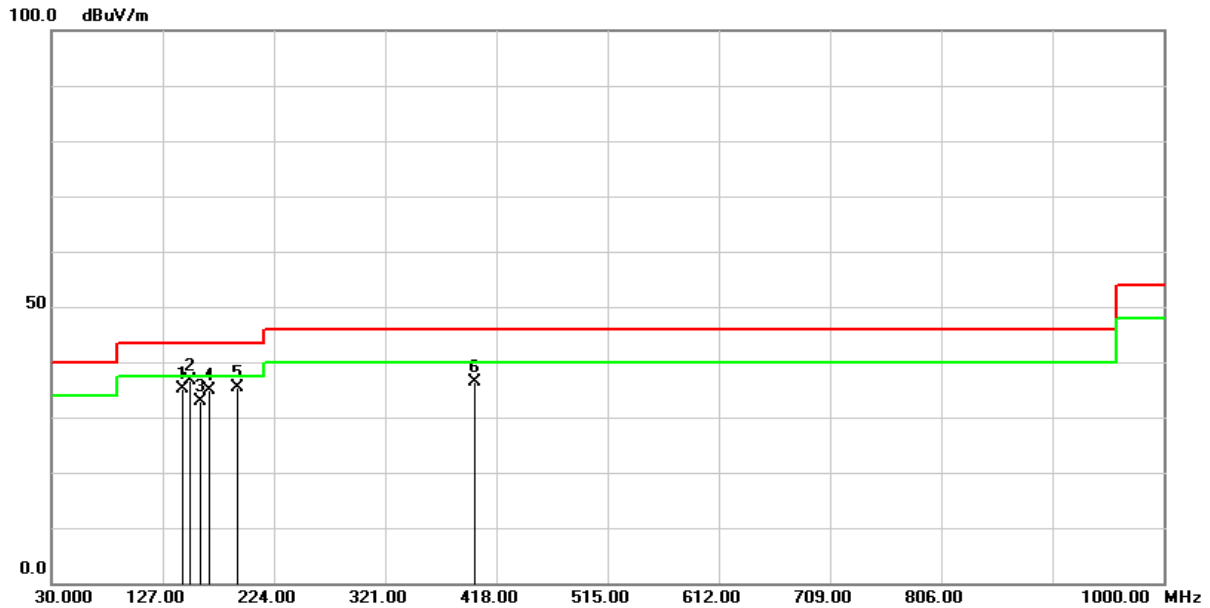

No.	Frequency (MHz)	Reading (dBuV/m)	Correct Factor (dB/m)	Result (dBuV/m)	Limit (dBuV/m)	Margin (dB)	Remark
1	144.4600	45.68	-10.56	35.12	43.50	-8.38	QP
2	150.2800	47.12	-10.51	36.61	43.50	-6.89	QP
3	159.9800	43.72	-10.76	32.96	43.50	-10.54	QP
4	167.7400	45.56	-10.76	34.80	43.50	-8.70	QP
5	191.9900	48.43	-13.16	35.27	43.50	-8.23	QP
6	399.5700	42.43	-6.06	36.37	46.00	-9.63	QP

Remark :

1. Correction Factor = Antenna factor + Cable loss – Amplifier gain
2. Result Value = Reading Level + Correct Factor
3. Margin Level = Result Value – Limit Value
4. The other emission levels were very low against the limit

Test Mode :	Transmit(802.11g)	Test Date :	2024/09/23
Test Channel :	CH06(2437MHz)	Temperature :	24.5 °C
Polarization :	Vertical	Relative Humidity :	54 %

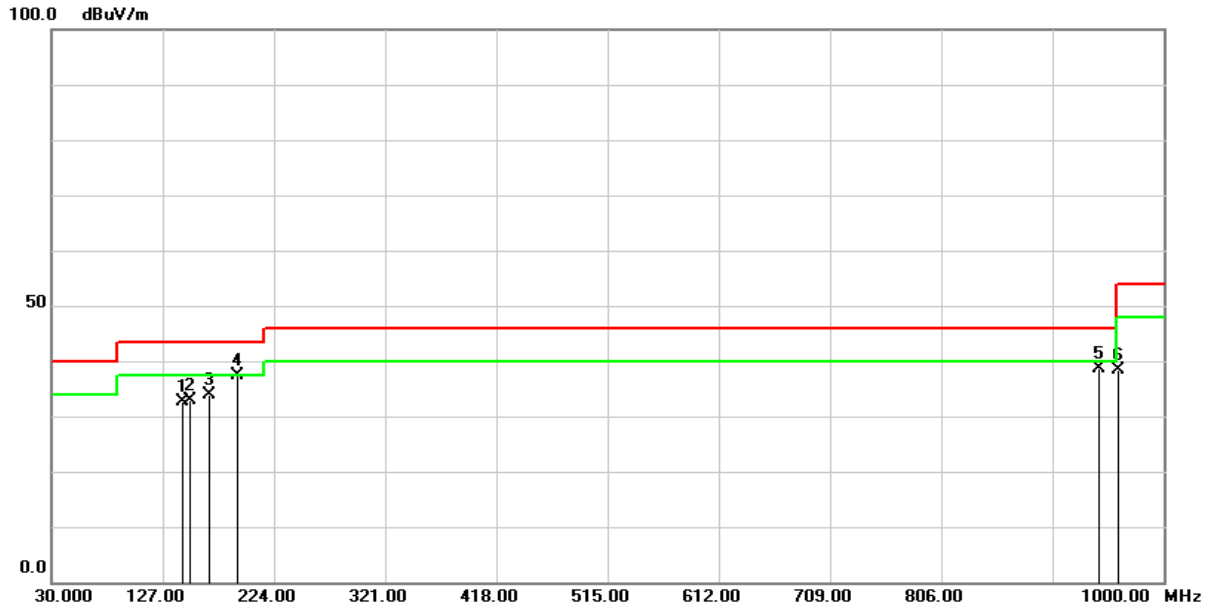

No.	Frequency (MHz)	Reading (dBuV/m)	Correct Factor (dB/m)	Result (dBuV/m)	Limit (dBuV/m)	Margin (dB)	Remark
1	144.4600	43.23	-10.56	32.67	43.50	-10.83	QP
2	150.2800	43.48	-10.51	32.97	43.50	-10.53	QP
3	167.7400	44.62	-10.76	33.86	43.50	-9.64	QP
4	191.9900	50.45	-13.16	37.29	43.50	-6.21	QP
5	943.7400	32.97	5.77	38.74	46.00	-7.26	QP
6	959.9808	32.23	6.04	38.27	46.00	-7.73	QP

Remark :

1. Correction Factor = Antenna factor + Cable loss – Amplifier gain
2. Result Value = Reading Level + Correct Factor
3. Margin Level = Result Value – Limit Value
4. The other emission levels were very low against the limit

2.7 AC Conducted Emissions Measurement

2.7.1 Limit

Frequency (MHz)	FCC Part 15 Subpart C Paragraph 15.207 (dB μ V) Limit	
	Quasi-peak	Average
0.15 to 0.5	66 to 56*	56 to 46*
0.50 to 5.0	56	46
5.0 to 30.0	60	50

*Decreases with the logarithm of the frequency

2.7.2 Test Setup

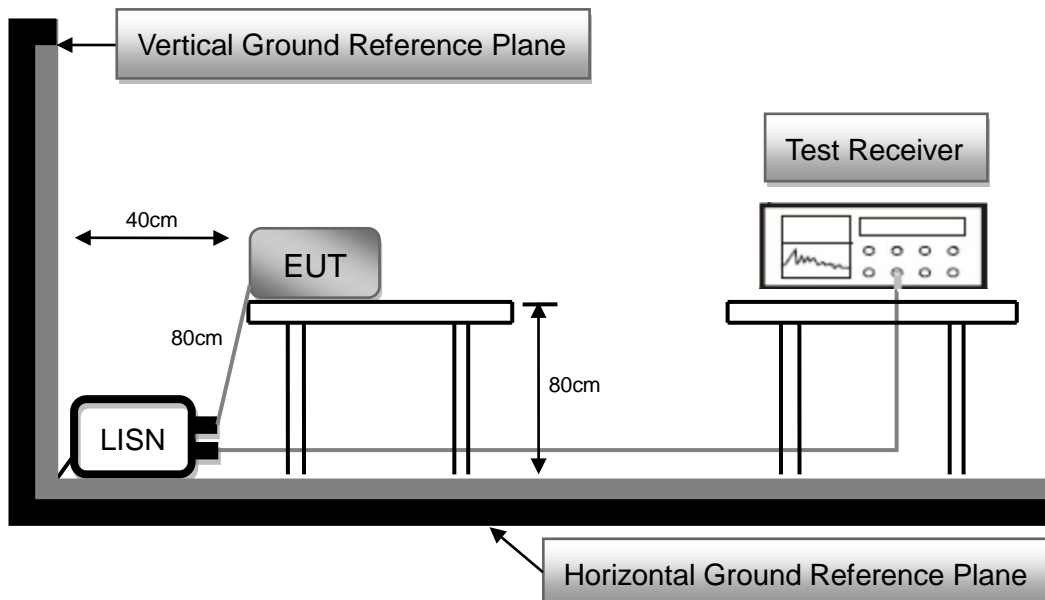

2.7.3 Test Procedure

1. Reference ANSI C63.10 : 2013 chapter 6.2
2. The EUT was placed 0.8 meter height wooden table from the horizontal ground plane with EUT being connected to power source through a line impedance stabilization network (LISN). The LISN at least be 80 cm from nearest chassis of EUT.
3. The line impedance stabilization network (LISN) provides 50 ohm/50uH of coupling impedance for the measuring instrument. All other support equipments powered from additional LISN(s).
4. Interrelating cables that hang closer than 40 cm to the ground plane shall be folded back and forth in the center forming a bundle. All I/O cables were positioned to simulate typical usage.
5. All I/O cables that are not connected to a peripheral shall be bundle in the center. The end of the cable may be terminated, if required, using the correct terminating impedance. The overall length shall not exceed 1 m.
6. The EMI test receiver connected to LISN powering the EUT. The actual test configuration, please refer to EUT test photos.
7. The receiver scanned from 150kHz to 30MHz for emissions in each of test modes. Conducted emissions were invested over the frequency range from 0.15MHz to 30MHz using a receiver bandwidth of 9kHz. A scan was taken on both power lines, Line and Neutral, recording at least six highest emissions.
8. The EUT and cable configuration of the above highest emission levels were recorded. The Test Data of the worst case was recorded.

2.7.4 Test Result

Test Voltage :	120Vac, 60Hz	Frequency Range:	0.15-30 MHz
Test Mode :	Transmit(802.11g)	6dB Bandwidth :	9 kHz
Test Date :	2024/09/23	Phase :	L
Temperature :	25.9°C	Humidity :	47 %

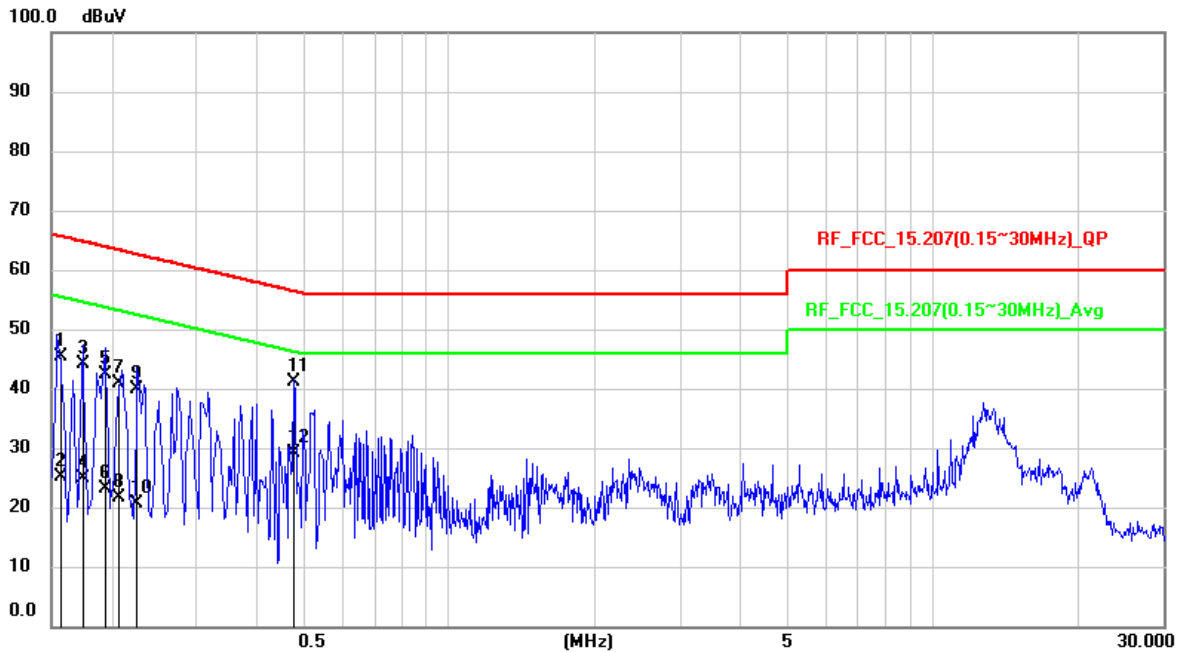

No.	Frequency (MHz)	Reading Level (dBuV)	Correct Factor (dB)	Measurement (dBuV)	Limit (dBuV)	Margin (dB)	Detector
1	0.158	35.48	9.83	45.31	65.57	-20.26	QP
2	0.158	15.28	9.83	25.11	55.57	-30.46	AVG
3	0.1733	34.18	9.83	44.01	64.8	-20.79	QP
4	0.1733	15.14	9.83	24.97	54.8	-29.83	AVG
5	0.1948	32.57	9.82	42.39	63.83	-21.44	QP
6	0.1948	13.26	9.82	23.08	53.83	-30.75	AVG
7	0.2066	31.07	9.82	40.89	63.34	-22.45	QP
8	0.2066	11.88	9.82	21.7	53.34	-31.64	AVG
9	0.2264	30.08	9.82	39.9	62.58	-22.68	QP
10	0.2264	10.71	9.82	20.53	52.58	-32.05	AVG
11	0.4771	31.19	9.83	41.02	56.39	-15.37	QP
12	0.4771	19.22	9.83	29.05	46.39	-17.34	AVG

Remark:

1. QP = Quasi Peak, AVG = Average
2. Correction Factor = Insertion loss of LISN + Cable loss
3. Measurement Value = Reading Level + Correct Factor
4. Margin Level = Measurement Value – Limit Value

Test Voltage :	120Vac, 60Hz	Frequency Range:	0.15-30 MHz
Test Mode :	Transmit(802.11g)	6dB Bandwidth :	9 kHz
Test Date :	2024/09/23	Phase :	N
Temperature :	25.9°C	Humidity :	47 %

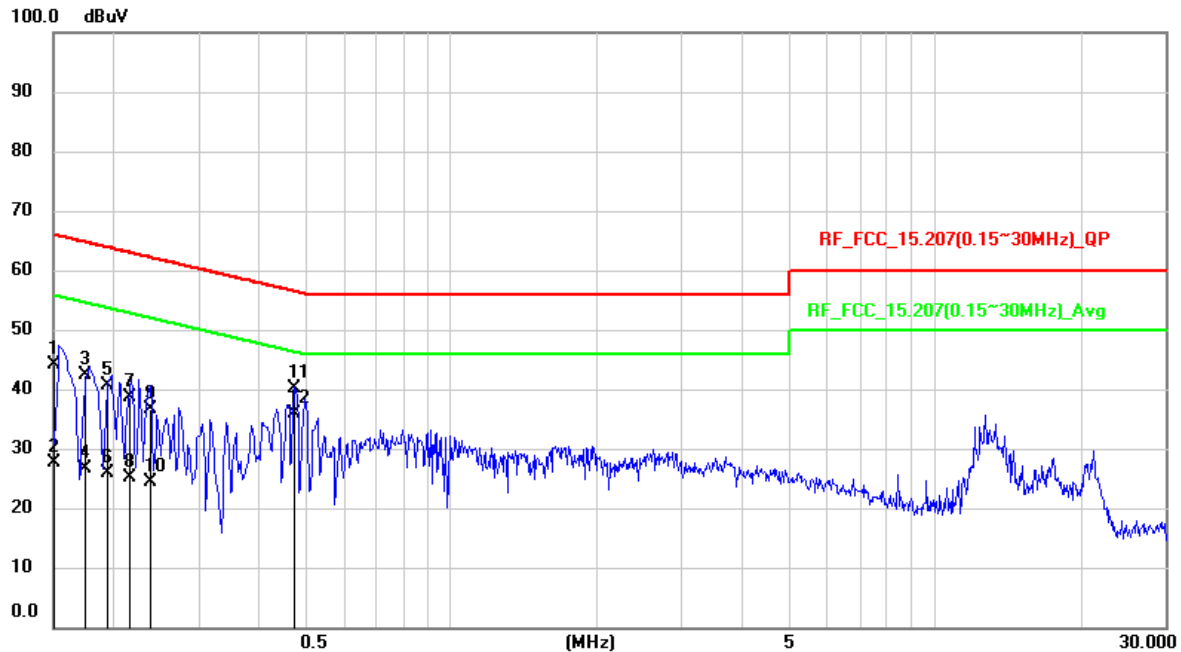

No.	Frequency (MHz)	Reading Level (dBuV)	Correct Factor (dB)	Measurement (dBuV)	Limit (dBuV)	Margin (dB)	Detector
1	0.1504	34.36	9.81	44.17	65.98	-21.81	QP
2	0.1504	17.76	9.81	27.57	55.98	-28.41	AVG
3	0.1734	32.6	9.82	42.42	64.8	-22.38	QP
4	0.1734	16.86	9.82	26.68	54.8	-28.12	AVG
5	0.1945	30.9	9.81	40.71	63.84	-23.13	QP
6	0.1945	16.14	9.81	25.95	53.84	-27.89	AVG
7	0.216	28.86	9.81	38.67	62.97	-24.3	QP
8	0.216	15.4	9.81	25.21	52.97	-27.76	AVG
9	0.238	26.81	9.81	36.62	62.17	-25.55	QP
10	0.238	14.47	9.81	24.28	52.17	-27.89	AVG
11	0.4739	30.34	9.82	40.16	56.45	-16.29	QP
12	0.4739	25.95	9.82	35.77	46.45	-10.68	AVG

Remark:

1. QP = Quasi Peak, AVG = Average
2. Correction Factor = Insertion loss of LISN + Cable loss
3. Measurement Value = Reading Level + Correct Factor
4. Margin Level = Measurement Value – Limit Value

--- END ---