

Quick Installation Guide

P/N: 5019031600



Warning Before Installation / Warnung vor der Installation / Waarschuwing voor installatie

- Power off the Network Camera as soon as smoke or unusual odors are detected. Netzwerkkamera bei Rauchentwicklung oder ungewöhnlichem Geruch sofort abschalten. Schakel de Netwerk Camera uit zodra u rook of ongebruikelijke geuren waarneemt.
- Do not place the Network Camera on unsteady surfaces. Netzwerkkamera nur auf feste Unterlagen abstellen. Plaats de Netwerk Camera niet op een instabiel oppervlak.
- Do not insert sharp or tiny objects into the Network Camera. Keine Fremdkörper, z. B. Nadeln, in die Netzwerkkamera einführen. Steek geen scherpe of zeer kleine objecten in de Netwerk Camera.
- Replacing or failing to properly install the waterproof components, e.g., cables or cable glands, will void our IP65/66/67 warranty. Ein Austausch oder die unsachgemäße Installation der wasserdichten Komponenten, z.B. Kabel oder Kabelverschraubungen, führt zum Verlust unserer IP65/66/67 Garantie. Als de waterdichte componenten, zoals kabels of kabelwartels, niet correct worden geplaatst of vervangen, is de garantie van de IP65/66/67 ongeldig.
- Refer to your user's manual for the operating temperature. Hinweise zur Betriebstemperatur siehe Benutzeranleitung. Zie de gebruikershandleiding voor informatie over de gebruikstemperatuur.
- Do not touch the Network Camera during a lightning storm. Netzwerkkamera bei Gewittern nicht anfassen. Raak de Netwerk Camera niet aan tijdens onweer.
- Do not drop the Network Camera. Netzwerkkamera nicht fallen lassen. Laat de Netwerk Camera niet vallen.



Zanim zaczniesz — zalecenia dotyczące bezpieczeństwa / Перед установкой / Upozornění před instalací

- W razie zauważenia dymu lub dziwnego zapachu wydobywającego się z kamery sieciowej, natychmiast odłącz zasilanie. Отключите питание сетевой видеокamеры, если появился дым или произошло сильное нагревание устройства. Pokud bude ze síťové kamery vycházet kouř nebo neobvyklý zápach, okamžitě ji vypněte.
- Nie ustawiaj kamery sieciowej na niestabilnych powierzchniach. Запрещается устанавливать сетевую видеокamerу на неровных поверхностях. Neumistujte síťovou kameru na nestabilní povrchy.
- Nie wkładaj do wnętrza obudowy kamery sieciowej żadnych przedmiotów (np. igieł itp.). Запрещается вставлять в сетевую видеокamerу какие-либо объекты, например иглы. Nevkládejte do síťové kamery žádné ostré či malé předměty.
- Zastępnienie lub nieprawidłowa instalacja wodoodpornych komponentów, np; kabli lub przepustów kablowych, unieważni twoją gwarancję IP65/66/67. Замена или ненадлежащая установка компонентов влагозащиты, например кабелей или кабельных сальников, приведет к аннулированию нашей гарантии в отношении защиты по классу IP65/66/67. Výměna nebo nezdafená instalace voděodolných komponentů, např. kabelů nebo kabelových spojek, zruší platnost naší záruky IP65/66/67.
- Zakres temperatury otoczenia zalecanej podczas pracy urządzenia znajdziesz w podręczniku użytkownika. Допустимый для эксплуатации диапазон температур указан в руководстве пользователя. Informace o provozní teplotě naleznete v uživatelské příručce.
- Nie dotykaj kamery sieciowej podczas burzy z wyładowaniami atmosferycznymi. Не дотрагивайтесь до сетевой видеокamеры во время грозы. Nedotýkejte se síťové kamery za bouřky.
- Nie upuszczaj kamery sieciowej z wysokości. Не допускайте падения сетевой видеокamеры. Nenechte síťovou kameru spadnout.

Package Contents / Packungsinhalt kontrollieren / Inhoud van de verpakking

檢查包裝內容物 / 検査包装内容 / パッケージ内容の確認

Vérifier le contenu de l'emballage / Verifi que o conteúdo da embalagem / Compruebe el contenido del embalaje

Sprawdź zawartość pakietu / Проверка комплекта поставки / Obsah balení

Verifi care il contenuto della confezione / Embalajın içindekileri Kontrol Edin /

Paketinnehåll / Kassens indhold / Isi Kemasan مكونات الحزمة

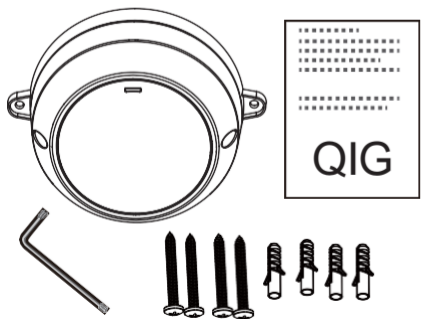

安裝前應注意事項 / 安装警告 / インストール前の注意

- 如果發現網路攝影機出現煙霧或聞到異味時，請立即關閉電源。如果网络摄像头冒烟或有异常气味，请立即关闭。煙や異常なおいに気が付いたら、直ちにネットワークカメラの電源を切ってください。
- 請勿將網路攝影機擺放在不穩定的物體上。切勿將网络摄像头放置在不稳定的表面上。不安定な場所にネットワークカメラを置かないでください。
- 請勿將任何物件插入網路攝影機，例如細針。切勿在网络摄像头中插入任何物体，如针状物等。ネットワークカメラに針のような物を差し込まないでください。
- 如果更換或是沒有正確安裝防水元件（例如纜線或纜線固定頭），將使本公司 IP65/66/67 的保固失效。如果替换了防水部件，或者防水部件安装不正确，如电缆或电缆密封套等，相关 IP65/66/67 项质保将会失效。ケーブルまたはケーブルグランドなどの防水部品を置き替えるか、または適切にインストールすることができない場合、当社の IP65/66/67 の保証は無効になります。
- セキュリティ基準（新規則第 34 条の 10）
- 有關操作時的溫度，請參閱使用者說明書。工作温度请参考用户手册。使用温度については、ユーザーマニュアルを参照してください。
- 閃電時，請勿碰觸網路攝影機。闪电时不要接触网络摄像头。雷が鳴っている時は、ネットワークカメラに触れないでください。
- 請勿讓網路攝影機掉落地面。切勿使网络摄像头坠落。ネットワークカメラを落とさないでください。

「本製品は 電気通信事業者（移动通信会社、固定通信会社、インターネットプロバイダ等）の通信回線（公衆無線 LAN を含む）に直接接続することができません。本製品をインターネットに接続する場合は、必ずルータ等を經由し接続してください。」



Avvertenza prima dell'installazione / Kurulum Öncesi Uyarılar / Varning innan installation

- Spegnera immediatamente la videocamera di rete se questa presenta fumo o un odore insolito. Ağ Kamerasından duman çıktığı görülür veya normal olmayan bir koku duyulursa Ağ Kamerasının elektrik bağlantısını kesin. Stäng av strömmen till nätverkskameran om det skulle ryka om den eller lukta konstigt.
- Non collocare la videocamera di rete su superfici instabili. Ağ Kamerasını dengersiz yüzeylere koymayın. Placera inte nätverkskameran på ostadiga ytor.
- Non inserire alcun oggetto nella videocamera di rete. Ağ Kamerasına herhangi bir nesne (örneğin, iğne) sokmayın. Sätt inte in några föremål i nätverkskameran såsom t.ex. nålar.
- La sostituzione o l'installazione non corretta di componenti a tenuta stagna, ad esempio cavi o premistoppa, determineranno l'annullamento della garanzia IP65/66/67. Kablo veya kablo rakoru gibi su geçirmez parçaların değiştirilmesi veya uygun şekilde monte edilmemesi IP65/66/67 garantimizi geçersiz kılacaktır.
- Att bytta eller felaktigt montera vattentäta komponenter såsom kablar eller kabelgenomföringar kommer att göra förverka vår IP65/66/67-garanti.
- Consultare il manuale dell'utente per le temperature di esercizio. Çalıştırma sıcaklığı için kullanım kılavuzuna başvurun. Se din användarmanual för drifttemperatur.
- Non toccare la videocamera di rete durante i temporali. Şimşek çakarken Ağ Kamerasına dokunmayın. Rör inte nätverkskameran när den åskar.
- Non far cadere la videocamera di rete. Ağ Kamerasını düşürmeyin. Tappa inte nätverkskameran.

Hardware Installation / Hardwareinstallation / Hardware installation تركيب الأجهزة

硬體架設 / 硬件安装 / ハードウェア・インストレーション

Installation du matériel / Instalacao de Hardware / Instalación del hardware

Instalacja sprzętu / Монтаж оборудования / Instalace hardwaru

Installazione hardware / Donanım Montajı / Installation av hårdvara

Installation af hardware / Pemasangan Perangkat Keras

1

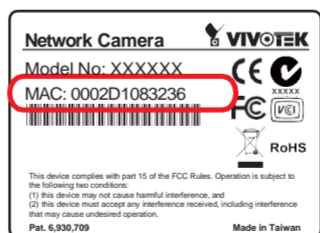

Consumption & Power Input
12V - 0.7A
PoE 802.3af class 0 - 42.5V/0.23A, 57V/0.17A



Avertissement avant installation / Aviso antes da instalação / Advertencia antes de la instalación

- Éteignez rapidement la caméra réseau si elle dégage de la fumée ou une odeur inhabituelle. Desligue a Câmara de Rede se vir fumo ou sentir cheiros estranhos. Apague la cámara de red si aparece humo o algún olor no habitual.
- Ne disposez pas la caméra réseau sur des surfaces instables. Não coloque a Câmara de Rede em superfícies instáveis. No coloque la cámara de red sobre superficies que no sean firmes.
- N'insérez pas d'objet dans la caméra réseau (p. ex. des aiguilles). Não introduza nenhum objecto dentro da Câmara de Rede, como agulhas, No inserte ningún objeto en la cámara de red, como agujas.
- Remplacez ou installez incorrectement les composants étanches, par exemple les câbles ou des presse-étoupes, annulera la garantie de votre IP65/66/67. Substituição ou falha ao instalar corretamente os componentes impermeáveis, por exemplo, cabos os receptáculos de cabos, anularão nossa garantia IP65/66/67.
- Consultez le guide d'utilisateur pour obtenir la température de fonctionnement. Consulte o manual do utilizador para obter informações sobre a temperatura de funcionamento. Consulte el manual del usuario para ver la temperatura de funcionamiento.
- Ne touchez pas à la caméra réseau lors d'un orage. Não toque na Câmara de Rede quando houver trovoadas. No toque la cámara de red si hubiera tormentas.
- Ne laissez pas tomber la caméra réseau. Não deixe cair a Câmara de Rede. No deje caer la cámara de red.



Advarsel inden installation / Peringatan Sebelum Pemasangan

- Slå strømmen fra kameraet så snart der kan lugtes røg eller usædvanlige lugte. Segera matikan Network Camera jika keluar asap atau tercium bau yang aneh.
- Placér ikke netværkskameraet på ustabile underlag. Jangan meletakkan Network Camera pada permukaan yang tidak stabil.
- Indfør ikke skarpe eller små objekter i netværkskameraet. Baca panduan pengguna untuk suhu pengoperasian.
- Udsiftning eller fejlagtig installation af de vandtætte komponenter, fx kabler eller kabelpakninger, vil sætte garantien for din IP65/66/67 ud af kraft. Penggantian atau kesalahan pemasangan komponen kedap air, misalnya kabel atau selubung kabel, akan membatalkan garansi IP65/66/67.
- Der henvises til brugervejledningen for driftstemperaturen. Jangan memasukkan benda tajam atau benda berukuran kecil ke dalam Network Camera.
- Berør ikke netværkskameraet i tordenvejr. Jangan menyentuh Network Camera saat terjadi badai kilat.
- Tab ikke netværkskameraet. Jangan menjatuhkan Network Camera.

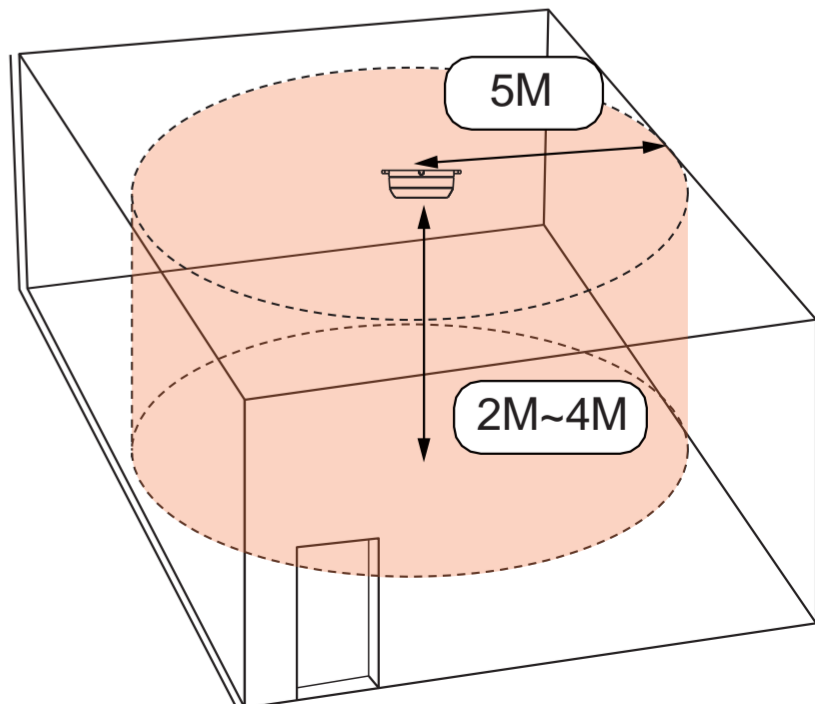

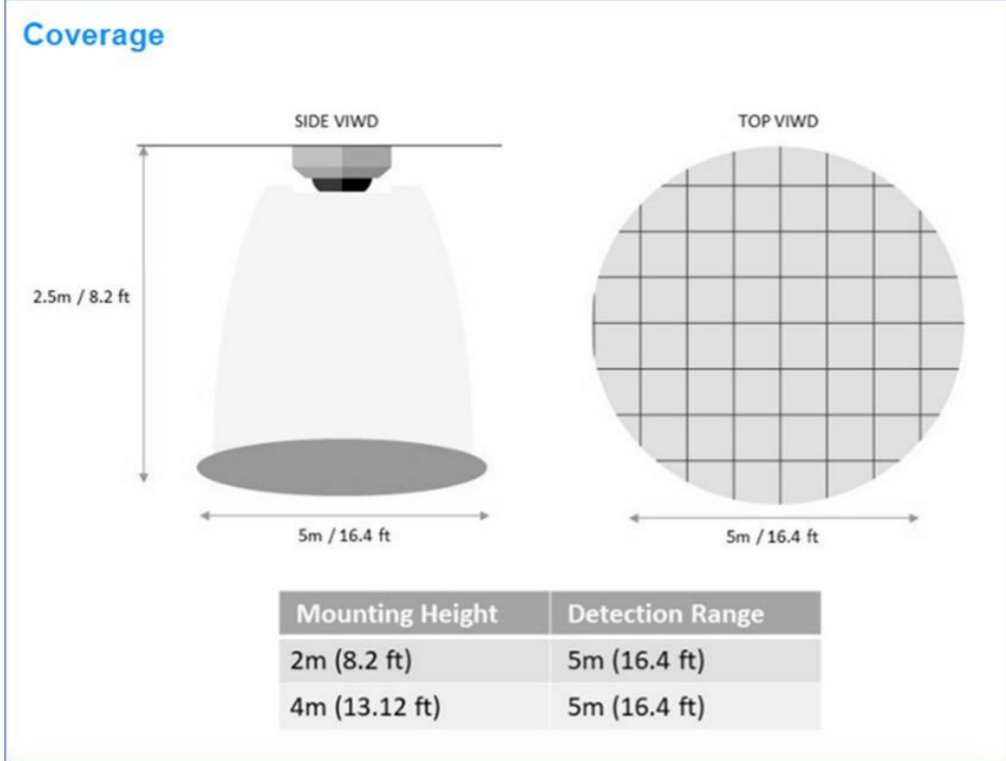

2

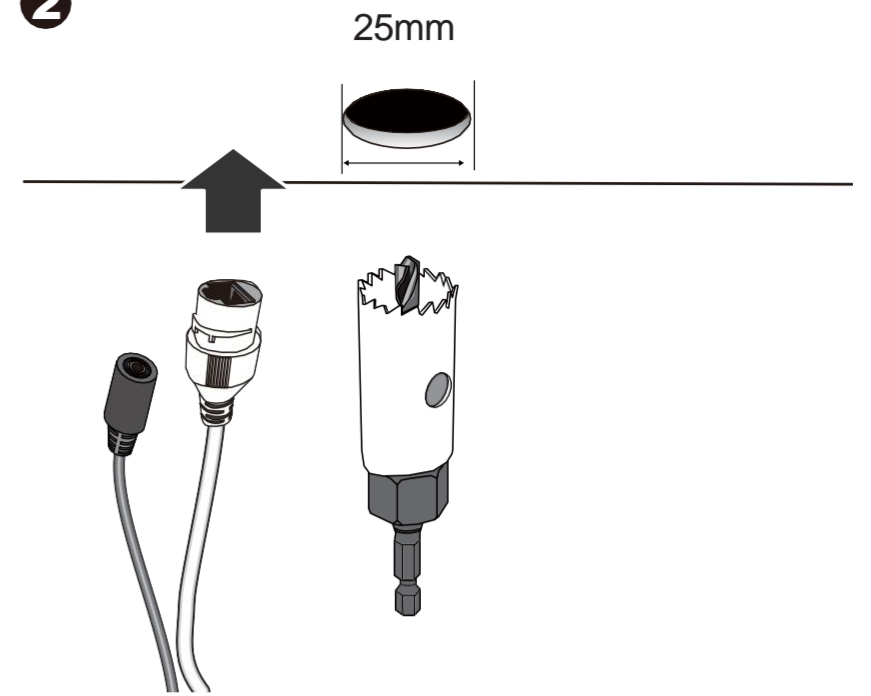

3

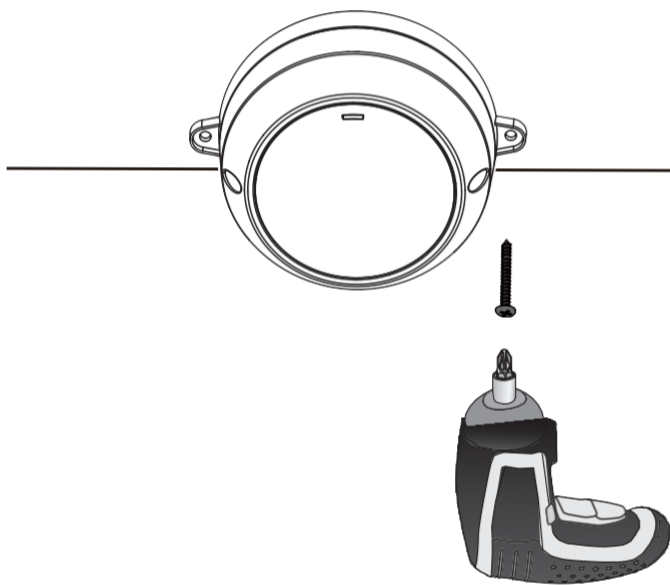

4

Please make sure your computer supports Bonjour; if not, download it from the link: https://support.apple.com/kb/DL999?viewlocale=en_US
 The IP of the sensor is last 6 digits of the MAC address. For example, if the MAC is aa:bb:cc:dd:ee:ff, the IP will be ddeeff.local.

5

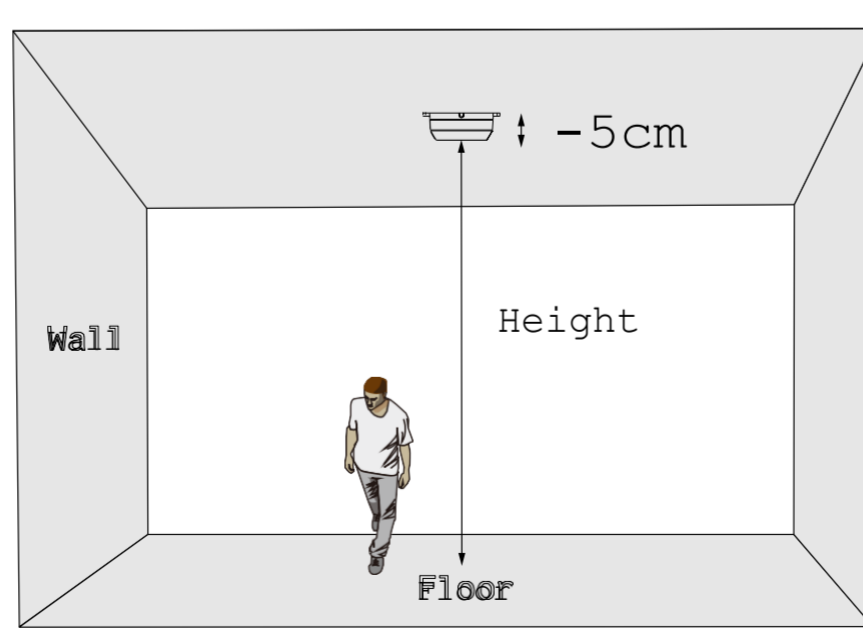
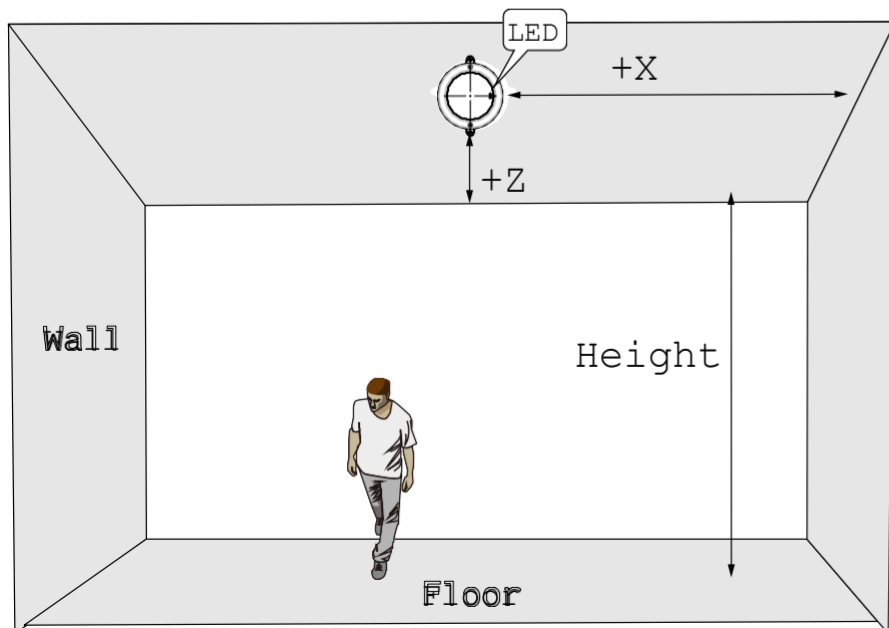
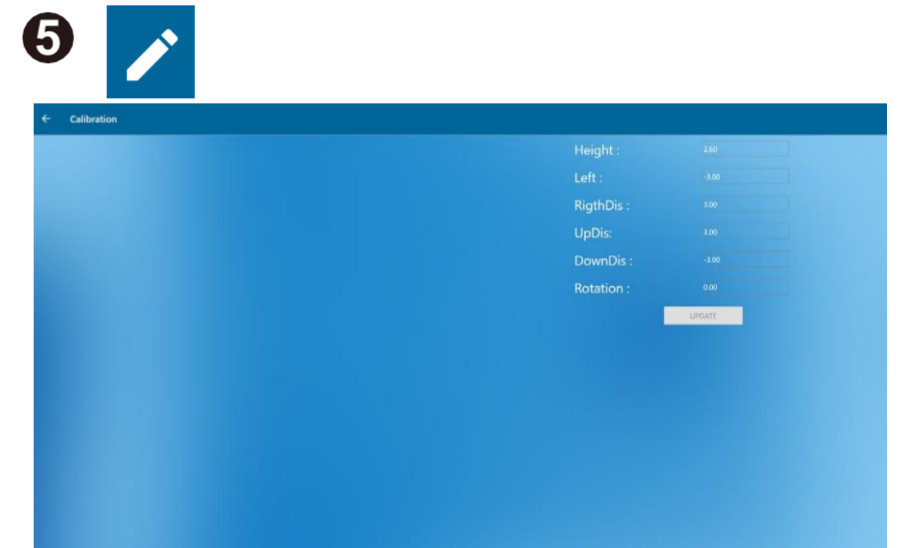

6 This page indicate the state when the radar is facing out with its LED on the right side.

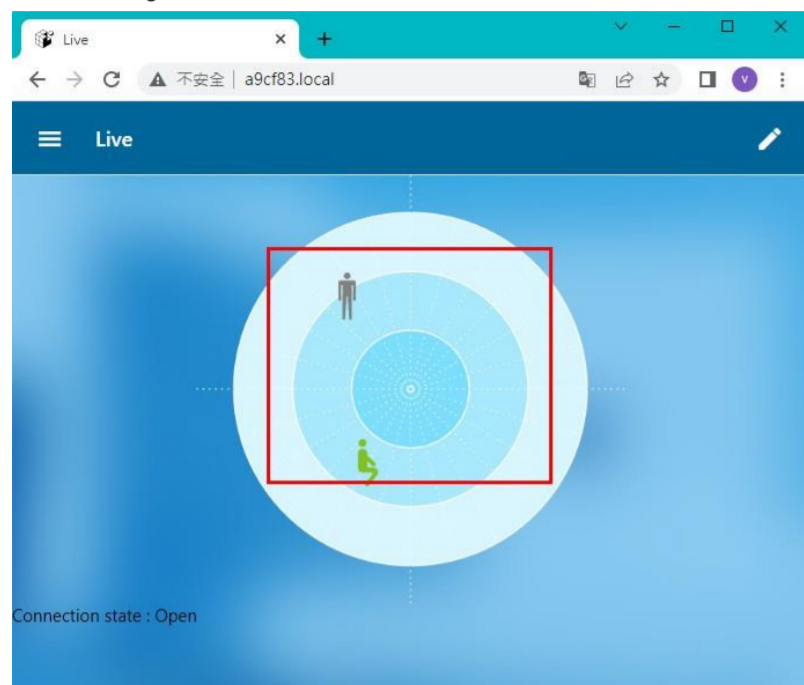

Icon	Meaning	Icon	Meaning (Fallen states occur only when the total detected number is 1 or 2.)
	The person is standaing and active		The person is suspected to have fallen. .
	The person is standing and static.		Fallen state countdown.
	The person is sitting and active.		Fallen state detected.
	The person is sitting and static.		The person is laying and active.
	The person is laying and static.		

FEDERAL COMMUNICATIONS COMMISSION INTERFERENCE STATEMENT

This equipment has been tested and found to comply with the limits for a Class B digital device, pursuant to part 15 of the FCC Rules. These limits are designed to provide reasonable protection against harmful interference in a residential installation. This equipment generates, uses and can radiate radio frequency energy and, if not installed and used in accordance with the instructions, may cause harmful interference to radio communications. However, there is no guarantee that interference will not occur in a particular installation. If this equipment does cause harmful interference to radio or television reception, which can be determined by turning the equipment off and on, the user is encouraged to try to correct the interference by one or more of the following measures:

- Reorient or relocate the receiving antenna.
- Increase the separation between the equipment and receiver.
- Connect the equipment into an outlet on a circuit different from that to which the receiver is connected.
- Consult the dealer or an experienced radio/ TV technician for help.

CAUTION:

Any changes or modifications not expressly approved by the grantee of this device could void the user's authority to operate the equipment.

RF Exposure warning

This equipment must be installed and operated in accordance with provided instructions and the antenna(s) used for this transmitter must be installed to provide a separation distance of at least 20 cm from all persons and must not be co-located or operating in conjunction with any other antenna or transmitter. End-users and installers must be provide with antenna installation instructions and transmitter operating conditions for satisfying RF exposure compliance.

Please contact authorized distributors for warranty and RMA service.
Visit <https://www.vivotek.com/support/warranty-rma>

All specifications are subject to change without notice.
Copyright © 2023 VIVOTEK INC. All rights reserved.

VIVOTEK INC.
6F, No.192, Lien-Cheng Rd., Chung-Ho, New Taipei City, 235, Taiwan, R.O.C.
[T: +886-2-82455282] F: +886-2-82455532 | E: sales@vivotek.com

VIVOTEK USA, INC.
2050 Ringwood Avenue, San Jose, CA 95131
[T: 408-773-8686] F: 408-773-8298 | E: salesusa@vivotek.com

VIVOTEK Europe
Zandsteen 15, 2132 MZ Hoofddorp Delta Electronics
T: +31 (0)20 800 3817 E: sales@vivotek.com