

# Customer Documentation

State: June 2016

FareGo Move MT|60

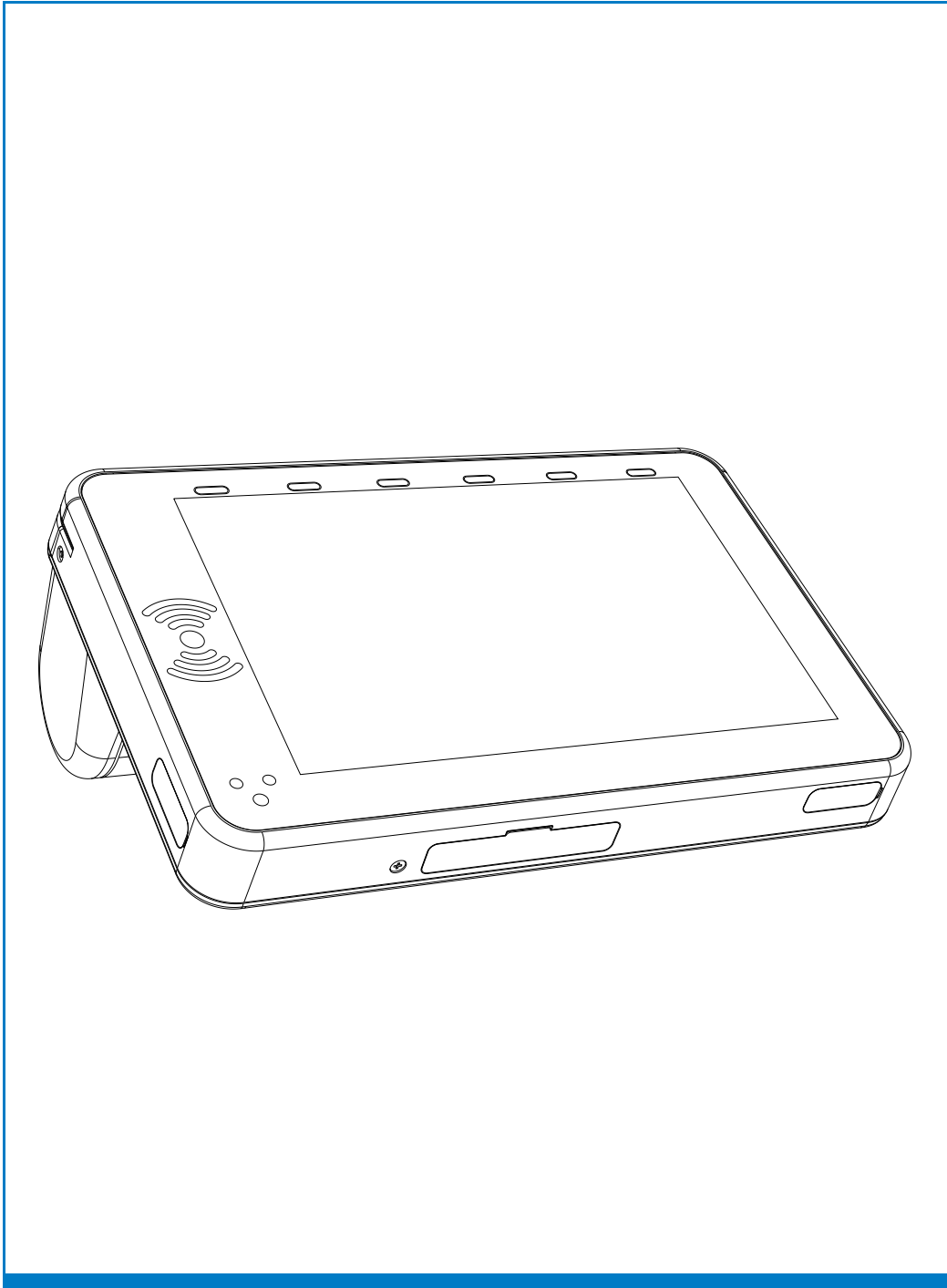

This manual, including all of its component parts, is copyright protected. Scheidt & Bachmann GmbH reserves all rights to its contents. Any use not expressly approved by copyright law is subject to prior approval by Scheidt & Bachmann GmbH. This applies particularly to copying, processing, translations and microfilming, as well as to storage and data processing in any electronic systems.

All contents of this manual shall be treated confidentially and shall not be transferred to any third party, either for their own commercial use or for any other client.

Since all information and facts are subject to technical changes, any liability for the data contained is hereby disclaimed. Modifications of technical details, in terms of information and illustrations are reserved. Make sure to follow the updating index. Scheidt & Bachmann GmbH cannot be held responsible for direct damage and/or possible consequential damage due to misuse by the customer or by third parties, unless the Product Liability Act (ProdHaftG) is concerned. In no event shall Scheidt & Bachmann GmbH be liable for any damage out of or in connection with the provision of the manual.

© 2016 Scheidt & Bachmann GmbH, Fare collection system (FCS)

Breite Straße 132 41238 Mönchengladbach

www.scheidt-bachmann.com

Subject to change.

## History

Version	Date	Change	Edit
0.8	18.09.2014	First draft	Stevens
1.0	24.09.2014	Formatting adapted to project specifications	Stevens
1.1	25.08.2015	Subject to alterations by project manager	Stevens
1.2	08.09.2015	Subject to alterations by project manager	Stevens
1.3	15.09.2015	Safety hint for outlet inserted	Stevens
1.4	03.12.2015	Power supply information changed	Stevens
1.5	03.06.2016	Safety hint for "distance between the radiator and body" inserted	Stevens
1.6	08.06.2016	Chapter "Protective Cover" inserted	Stevens
1.7	09.06.2016	Chapter sequence corrected. Changes in <b>Chapter 4.13</b>	Stevens
1.8	15.06.2016	Chapter 2 corrected.	Stevens

**Table 1-1**

## Chapter 1 Introduction

1.1	Preliminary observations .....	1-1
1.2	Explanation of symbols .....	1-1

## Chapter 2 Declaration of Conformity

## Chapter 3 Safety Features

3.1	Generally .....	3-1
3.1.1	Training .....	3-1
3.1.2	Warranty .....	3-1
3.2	Notes for Service .....	3-1
3.2.1	Electrostatic discharge .....	3-1
3.3	Maintenance .....	3-2
3.3.1	Proof .....	3-2
3.3.2	Cleaning intervals.....	3-2
3.3.3	Detergent.....	3-2
3.3.4	Define maintenance cycles.....	3-2

## Chapter 4 General Module Description

4.1	General.....	4-3
4.2	Standards .....	4-5
4.3	Life cycle costs .....	4-5
4.4	Dimensions.....	4-6
4.5	Printer .....	4-7
4.5.1	Technical Specifications .....	4-7
4.6	Barcode Imager.....	4-9
4.6.1	Technical Specifications .....	4-9
4.7	Battery.....	4-11
4.7.1	Technical Specifications .....	4-11
4.7.2	Operating time .....	4-11
4.7.3	Battery change .....	4-11
4.7.4	Battery Label.....	4-12
4.8	Display and touchscreen .....	4-13
4.8.1	Technical Specifications .....	4-13
4.9	CPU Modul.....	4-15
4.9.1	Technical Specifications .....	4-15
4.10	NFC - Reader .....	4-17
4.10.1	Cards Standards.....	4-17
4.10.2	eTicketing Standards .....	4-17
4.11	Magnetic Stripe Reader .....	4-19
4.11.1	Technical Specifications .....	4-19
4.12	Communication Modules .....	4-21
4.12.1	Bluetooth.....	4-21
4.12.2	WiFi.....	4-21
4.12.3	Mobile .....	4-21
4.12.4	USB.....	4-21
4.12.5	GPS (optional) .....	4-21
4.13	Protective Cover .....	4-23

## Chapter 5 Commissioning

5.1	Insert SIM, SAM, and micro SD Card.....	5-1
5.2	Insert battery .....	5-1
5.3	Recharge battery.....	5-2
5.4	Insert Paper .....	5-3
5.5	Switch On/Off .....	5-6
5.6	First Start .....	5-6

## Chapter 6 Explanation of terms

*THIS PAGE INTENTIONALLY BLANK.*

# Chapter 1 Introduction

## 1.1 Preliminary observations

The aim of this manual is to provide knowledge on handling and work processes that ensure that the device is working properly throughout its lifetime.

All activities that are necessary to meet this requirement, were included in this manual

All activities can be performed by the staff, safely, easily, ergonomically and without tools.

### Organization of This Guide

1. Chapter - Introduction
2. Chapter - Declaration of Conformity
3. Chapter - Safety Features
4. Chapter - General Module Description
5. Chapter - Commissioning
6. Chapter - Explanation of terms

## 1.2 Explanation of symbols



*This symbol indicates a **WARNING**. A detailed description of the particular hazard will appear next to the symbol in bold, italic print.*



*This symbol indicates a **CAUTION**. A detailed description of the particular hazard will appear next to the symbol in bold, italic print.*



*This symbol indicates that more **INFORMATION** follows. A detailed description of the particular hazard will appear next to the symbol in bold, italic print.*



*This symbol indicates that **lubrication is necessary**. A detailed description of the task will appear next to the symbol in bold, italic print.*



*This symbol indicates possibility of **ELECTRICAL HAZARD**. A detailed description of the particular hazard will appear next to the symbol in bold, italic print.*



*This symbol indicates an ESD HAZARD. A detailed description of the particular hazard will appear next to the symbol in bold, italic print.*



*This symbol indicates a RISK OF BURNS. A detailed description of the particular hazard will appear next to the symbol in bold, italic print.*



## Chapter 2 Declaration of Conformity



This Declaration is valid as soon as CE,FCC and IC certifications are available.

**NOTICE:**

*This device complies with Part 15 of the FCC Rules and with Industry Canada licence-exempt RSS standard(s).*

*Operation is subject to the following two conditions:*

- 1. this device may not cause harmful interference, and*
- 2. this device must accept any interference received, including interference that may cause undesired operation.*

*Le présent appareil est conforme aux CNR d'Industrie Canada applicables aux appareils radio*

*exempts de licence. L'exploitation est autorisée aux deux conditions suivantes:*

*(1) l'appareil ne doit pas produire de brouillage, et*

*(2) l'utilisateur de l'appareil doit accepter tout brouillage radioélectrique subi, même si le brouillage est susceptible d'en compromettre le fonctionnement.*

**NOTICE:**

*Changes or modifications made to this equipment not expressly approved by (manufacturer name) may void the FCC authorization to operate this equipment.*

**Radiofrequency radiation exposure Information:**

*This equipment complies with FCC radiation exposure limits set forth for an uncontrolled environment. To ensure the minimum operating distance between the radiator and your body a protective cover is attached to the equipment. See **Chapter 4.13** for more details. This protective cover must not be removed if the equipment is used in the USA or Canada. This transmitter must not be co-located or operating in conjunction with any other antenna or transmitter.*

*The radiated output power of the device is far below the FCC radio frequency exposure limits. Nevertheless, the device shall be used in such a manner that the potential for human contact during normal operation is minimized.*

*For body worn operation, this equipment has been tested and meets the FCC RF exposure guidelines when used with the Scheidt & Bachmann accessories supplied or designated for this product. Use of other accessories may not ensure compliance with FCC RF exposure guidelines.*

**NOTE:** This equipment has been tested and found to comply with the limits for a Class B digital device, pursuant to Part 15 of the FCC Rules. These limits are designed to provide reasonable protection against harmful interference when the equipment is operated in a commercial environment. This equipment generates, uses, and can radiate radio frequency energy and, if not installed and used in accordance with the instruction manual, may cause harmful interference to radio communications. Operation of this equipment in a residential area is likely to cause harmful interference in which case the user will be required to correct the interference at his own expense.

**NOTE:** This equipment has been tested and found to comply with the limits for a Class B digital device, pursuant to Part 15 of the FCC Rules. These limits are designed to provide reasonable protection against harmful interference in a residential installation. This equipment generates, uses and can radiate radio frequency energy and, if not installed and used in accordance with the instructions, may cause harmful interference to radio communications. However, there is no guarantee that interference will not occur in a particular installation. If this equipment does cause harmful interference to radio or television reception, which can be determined by turning the equipment off and on, the user is encouraged to try to correct the interference by one or more of the following measures:

- Reorient or relocate the receiving antenna.
- Increase the separation between the equipment and receiver.
- Connect the equipment into an outlet on a circuit different from that to which the receiver is connected.
- Consult the dealer or an experienced radio/TV technician for help.

## Chapter 3 Safety Features

### 3.1 Generally



**All operations such as installation, service, and maintenance must be performed only by trained and qualified personnel! Incorrectly performed installation, maintenance or repair actions may damage the unit.**



**The manual is subject to constant revisions due to constantly new discoveries and newly emerging as experiences from long-term use. Check your documentation is always up to date.**

#### 3.1.1 Training



**The manual alone is not capable of performing the service. In addition to the documents a training at Scheidt & Bachmann is possible.**

**To carry out maintenance and repair work on the device, the contained in this document has to be considered in the current version.**

#### 3.1.2 Warranty

The proper execution of all maintenance and repair work, particularly the observance of maintenance intervals and the correct and proper implementation of service activities with the tools and practices described in these documents, is a prerequisite for the validity of the contractual warranty agreement.

Instructions to service personnel that are generated from the maintenance framework of your software application shall comply with the statements of these documents, otherwise the contract warranty lose their validity.

The power supply is designed exclusively for the power supply of the device. When used in other applications, the contract warranty will be invalid.

The lower limit of the storage temperature of -20 ° C must not be exceeded.

### 3.2 Notes for Service

Before opening the device, the accumulator and the power supply had to be removed.

#### 3.2.1 Electrostatic discharge



**The components are used in the device, can be destroyed by electrostatic discharge. For this reason, generally wear a grounding ring during maintenance -and repair work and work in the workshop. During Service actions in the field, where direct or indirect contact with electrical components can occur, the use of a grounding ring is recommended.**

### 3.3 Maintenance

- 3.3.1 Proof**                    The Proof of maintenance cycle compliance and the regularity of the maintenance and repair work is up to the customer.
- 3.3.2 Cleaning intervals**                    The cleaning intervals had to be chosen so that, depending on the frequentation, no dangerous levels of paper dust and dirt can arise.
- 3.3.3 Detergent**                    By using detergent for plastic parts, the manufacturer information shall be followed so that these parts do not become brittle.
- 3.3.4 Define maintenance cycles**                    Scheidt & Bachmann reserves the right to change the guidelines of the maintenance cycles. Especially the printer. As a result of the knowledge from field

# Chapter 4 General Module Description

## 4.1 General

The following illustrations show a list of all, for the users certain, components of the MTJ60.

- ① Reading area for contactless Smart Cards
- ② Hotkeys
- ③ Display / Touchscreen
- ④ micro SIM card slot
- ⑤ Light sensor / status LEDs
- ⑥ SAM card slot
- ⑦ micro SD card slot

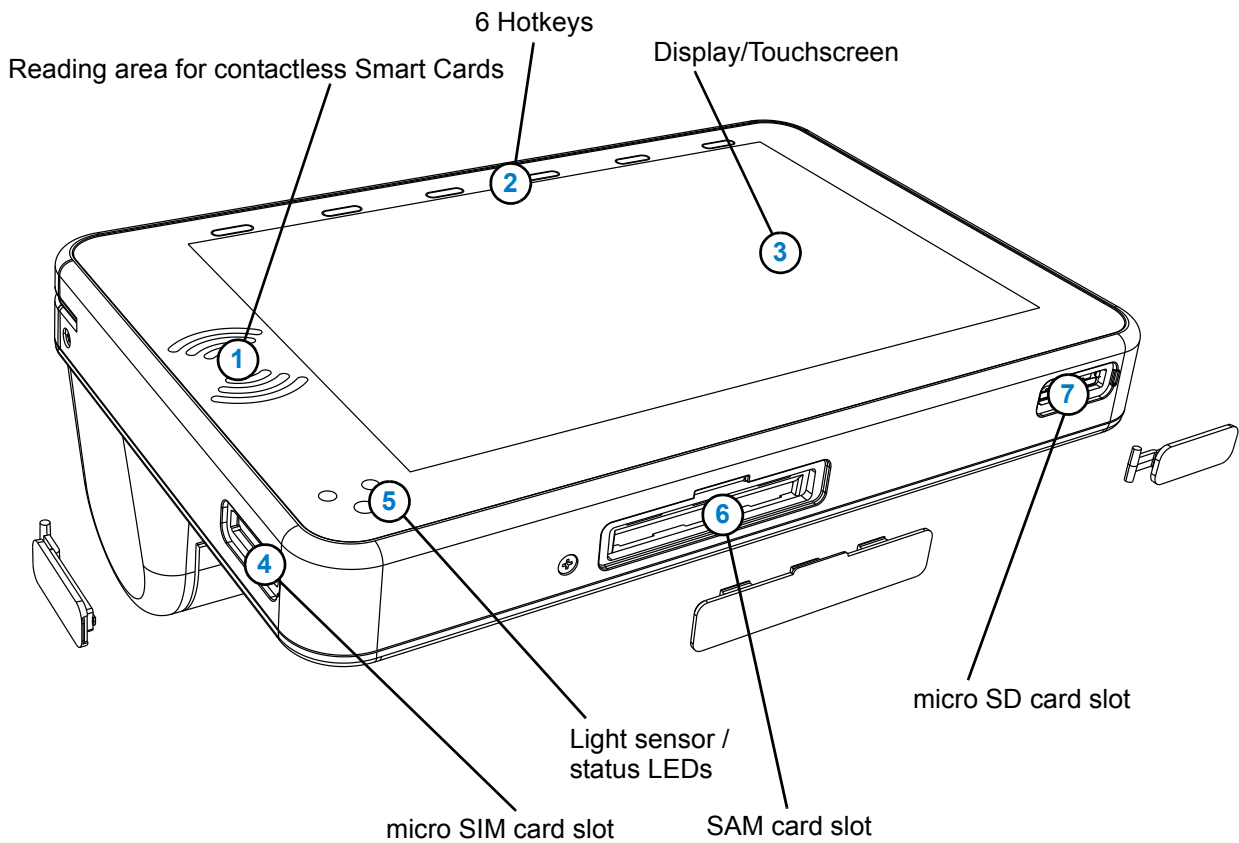
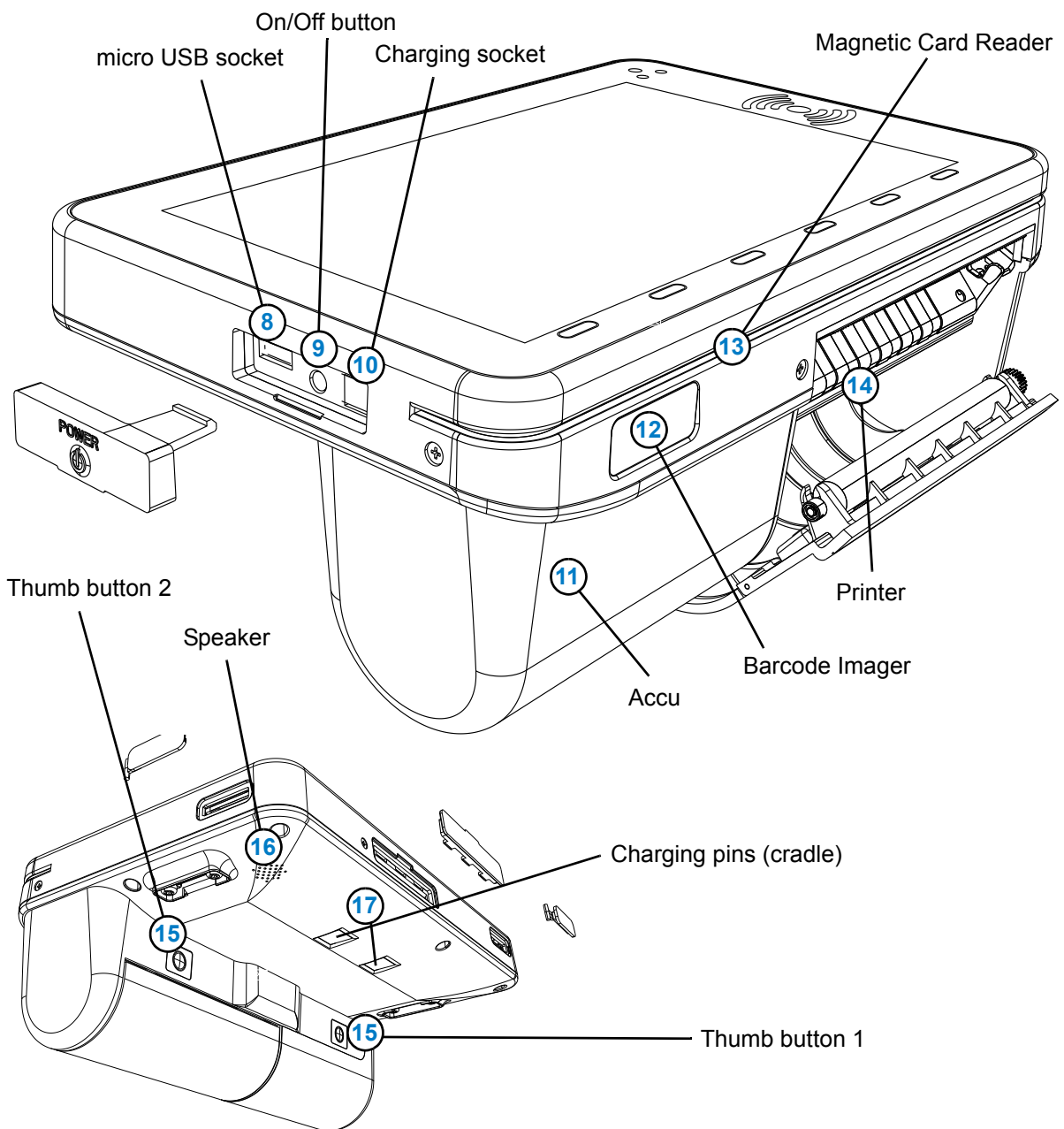

Figure 4-1: Component Overview 1

- ⑧ micro USB socket
- ⑨ On/Off button
- ⑩ Charging socket
- ⑪ Accu
- ⑫ Barcode Imager
- ⑬ Magnetic Card Reader
- ⑭ Printer
- ⑮ Thumb buttons
- ⑯ Speaker
- ⑰ Charging pins (cradle)



**Figure 4-2: Component Overview 2**

## 4.2 Standards

The MT|60 conforms to the following standards:

- **EN60950-1 Edition 2, IEC60950-1** - safety
- **EN60825-1, IEC60825-1** - Safety of laser products  
(The MT60 do not bear any laser. The barcode imager works with a LED aimer in compliance to class 1)
- **IEC60529, IP54 - IK07** Protection of enclosures
- **Radio** - R&TTE Direktive
- **EN 55022 Class B** - electromagnetic compatibility (EMC)
- **EN 55024** - noise immunity characteristics
- **Approvals cTÜV-Süd-us (NRTL) and FCC** and IC- regulations conformities, approvals
- **CE, RoHS, WEEE** - conformities and guidelines
- **ETSI EN 300019-2-7** - vibration resistance

## 4.3 Life cycle costs

All components of the MT | 60 are subject to aging. This wear automatically picks up after a few years. These components must be revised or replaced before the their life cycle end is reached, So before the aging process/wear of the components leads to major disruptions.

Parts in this context are:

- Battery
- Display
- Printer
- Paper tray
- SD-Card

## 4.4 Dimensions

- Length: 198,0 mm
- Width: 128,5 mm
- Height control unit: 30,0 mm
- Height incl. Battery u. Printer tray: 77,0 mm

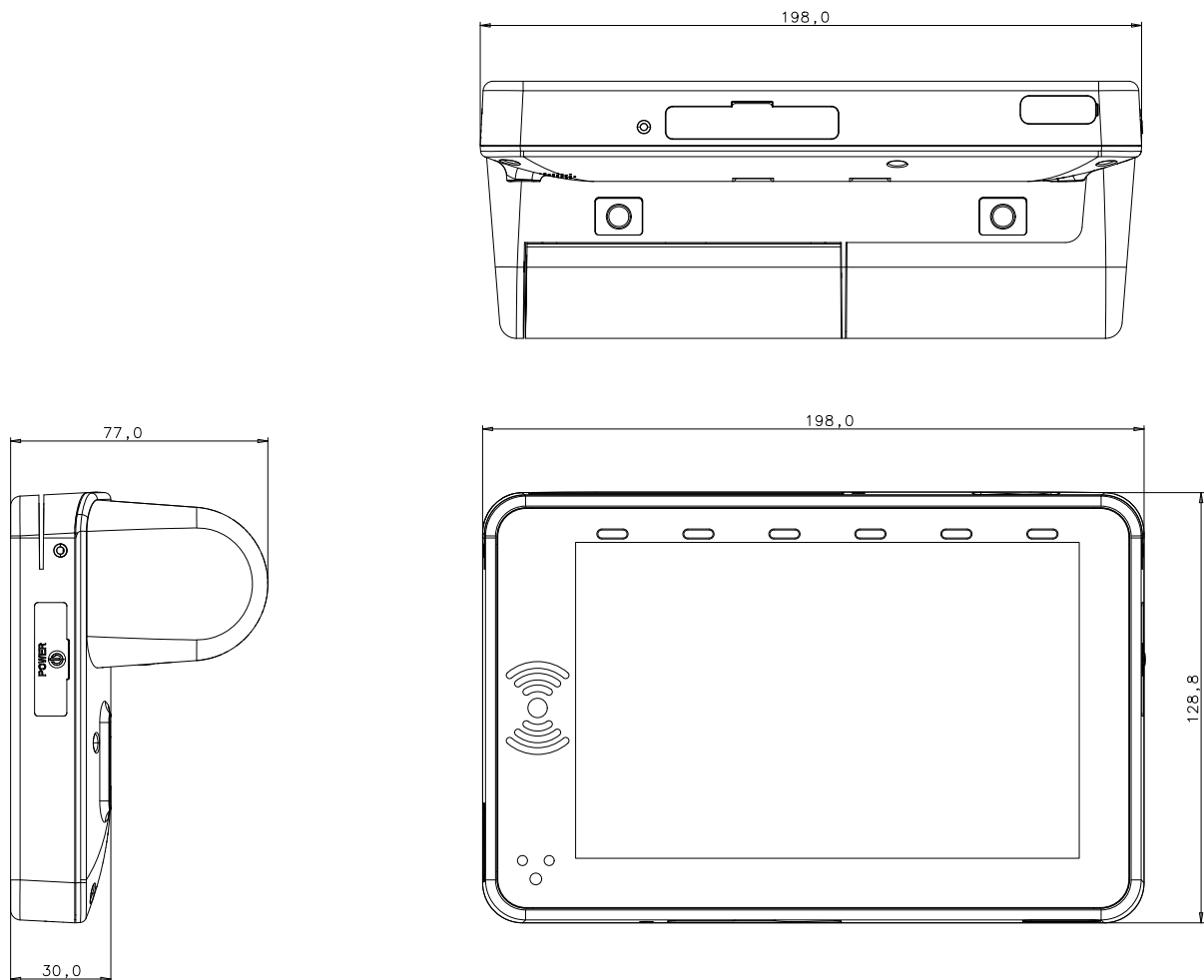

**Figure 4-3:** Dimensions



## 4.5 Printer

The MT|60 is equipped with a high performance thermal printer for printing tickets and receipts. The printer is integrated in the case of the MT|60.

### 4.5.1 Technical Specifications

- Resolution: 200 dpi
- Paper width: 82,5 mm
- Print width: Effective printing width max. 72 mm
- Maximum allowed paper weight: 60 - 80 g/m<sup>2</sup>
- Paper feed: "Easyload" Paper-insertion mechanism
- Print speed: 10 cm Ticket in max. 10 Seconds.
- Paper tear-off edge: Manual separation edge with corrosion-resistant metal edge
- Paper capacity: 10 m

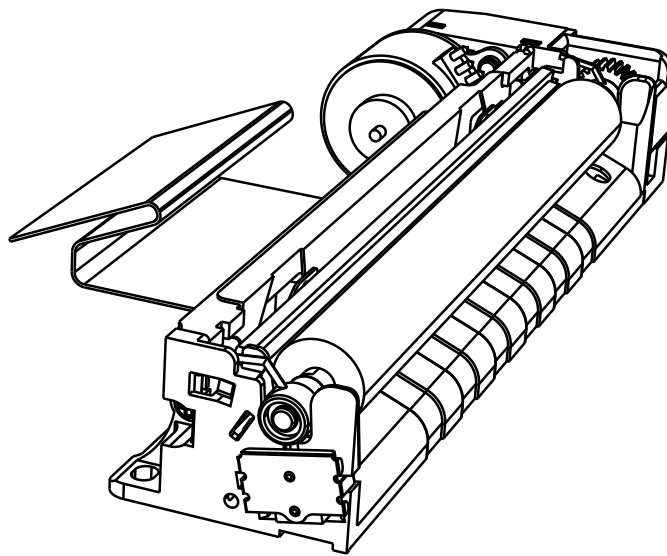

Figure 4-4: Printer

*THIS PAGE INTENTIONALLY BLANK.*

## 4.6 Barcode Imager

For the evaluation of barcodes (1D/2D) a barcode-imager is integrated in the MTJ60.

### 4.6.1 Technical Specifications

The imager includes a CMOS camera for reading bar codes from a paper template or from a screen of a cell phone.

The bar code reader supports 1D and 2D barcodes. Accordance with the following specification.

- 1-D Barcodes: Code 128
- 2-D Barcodes: Aztec
- PDF417
- QR Code

Data of the barcode reader:

- Reading range: 6-15 cm
- LED Eye Safety: Class 1 category (safest class)

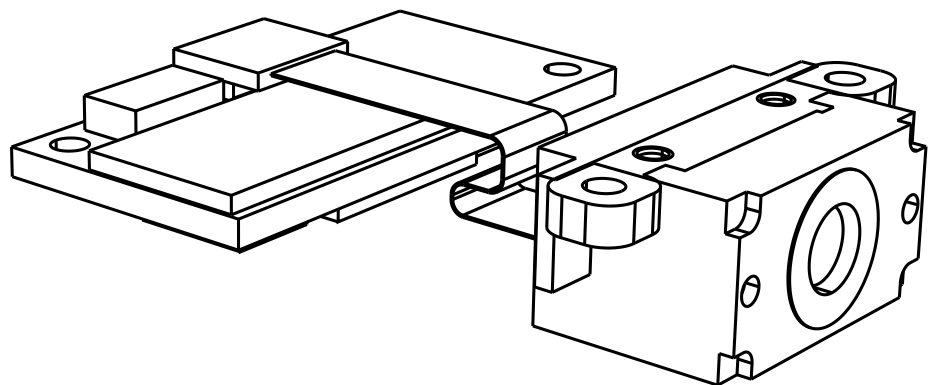

**Figure 4-5:** Barcode Imager

**Optional: Camera with 5 mega pixels eCAM57 (S&B Art. # 51802760)**

*THIS PAGE INTENTIONALLY BLANK.*

## 4.7 Battery

During mobile operation the device is powered by a powerful Li-Ion battery.

### 4.7.1 Technical Specifications

- Voltage: 7,2 V
- Charging voltage: 8.4 V
- Power: 24.48 Wh
- Capacity: 3400 mAh
- max. Charging current: 1625 mA
- max. Current drain: 4875 mA
- Charging time: <5 hours to 10% - 90% of the charge capacity
- Battery replacement: Battery replacement without tools in operation (Hot swapping)
- Battery technology: lithium-ion battery (no memory effect)
- Discharge temperature: -20 ° C to + 60 ° C

### 4.7.2 Operating time

The device runtime is >8 hours at normal shift conditions. The operating time depends on the software applications, wireless operation settings, power management settings, the brightness of the LCD screen and the ambient conditions.

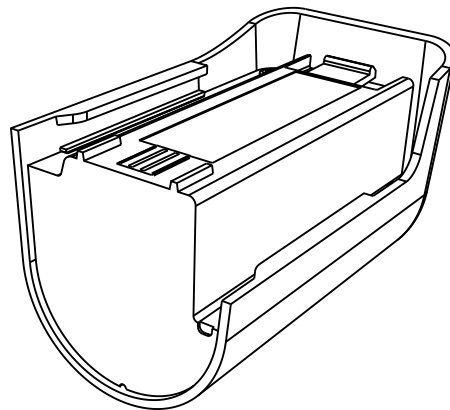

Figure 4-6: Battery

### 4.7.3 Battery change

The device has an integrated energy storage (backup battery) that allows battery replacement without shutting down the unit (hot swapping). With the removal of the battery, the device goes into Sleep mode and reduced inter alia the back light of the display to reduce the power consumption of the integrated energy storage.

The integrated energy storage is charged in operation mode by the battery. This allows a continuous operation of the device.

The internal energy storage can backup the device for a period of about 5 minutes to replace the battery.



***The outlet to recharge the MT-60 must be installed near the device and must be easily accessible.***

#### 4.7.4 Battery Label

Model No.	Nominal Voltage, V dc	Capacity, Ah/Wh	Maximum Charging Voltage, V dc	Maximum Charging Current, A	Maximum discharge Current, A	Dis-charge Cutoff Voltage, Vdc	Cell Config xS/yP	Cell Mfg.	Cell Model Number
2S1P NCR-18650 BF	7.2	3.35Ah / 24.12Wh	8.4	1.6	4.8	5.0	2S-1P	Panasonic	NCR-18650B F



**The MT 60 provided with a power supply "19V/max 3,3A". The output voltage imply the feature of safety extra low voltage as a limited power source. During connection to the ac/dc source the batteries recharge. It need not more than 4 1/2h to recharge the battery to full condition.**



**Caution: use this power supply provided by Scheidt & Bachmann only. Otherwise a damage or risk of fire may cause.**



**The MT60 provided with a removable battery type FareGo Move MT60 Battery cpl. 86 34471 0.**

**The Battery consisting of UL-recognized Li-cells and a battery management system (BMS) are in compliance with UL2054. The safeties are tested and recognized by an UL-Investigation and reported to BBFS2/MH45433. Additional to the BMS an internal fuse ensure a "limited power source" output voltage.**

**This battery comply to safety standards as follows: IEC60950-1, LPS, UL2054, IEC62133, UN38.3.**



**Caution:**

**Replace battery with type MT60 - 86 34471 0 only! Otherwise it may cause a Risk of Fire and Explosion.**

**Do Not Open, Crush, Heat Above +55C or incinerate.**

## 4.8 Display and touchscreen

The device has a high resolution display with a capacitive multi-touch screen.

### 4.8.1 Technical Specifications

- Screen size: 7"
- Resolution: 1.280 x 800 Pixel
- Colors: 16,7 Millionen
- Touchscreen: kapazitiv, multitouch
- Glas: GORILLA® GLASS

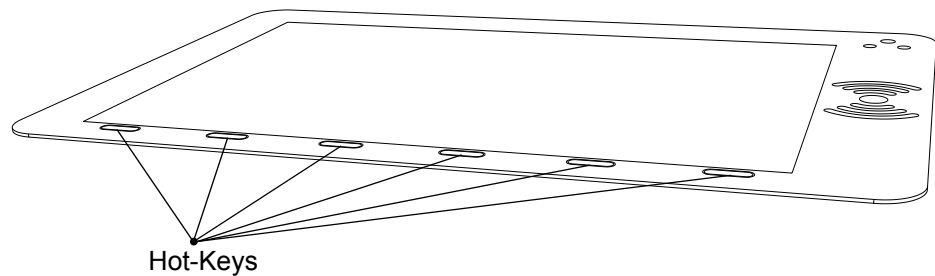

**Figure 4-7:** Display and Touchscreen

If the MT | 60 is rotated, the display is rotated into the required direction (Transverse and upright).

This is detected by an integrated position sensor

The functions of the hot keys are also rotated when rotating the screen contents. (This means that for example the function of the upper button is assigned, is always on the top button).

The integrated light sensor adjusts the brightness of the display automatically to the ambient brightness. The brightness can also be adjusted manually for each user.

*THIS PAGE INTENTIONALLY BLANK.*



## 4.9 CPU Modul

The CPU of the MT|60 is based on a Freescale™ i.MX6 Plattform.

The MT|60 is equipped with two SD card slots:

The first SD card slot is disposed on the CPU module and is not accessible from the outside.

The second SD card slot is located on the baseboard and is accessible from the outside. Write access is possible to the SD card.

### 4.9.1 Technical Specifications

- Processor (Single Core): Freescale™ i.MX6 ARM® Cortex™ A9, 1.0 GHz per Core, 1MB Level 2 Cache
- Memory: 1 GB  
Total Memory: 16 GB of memory via an internal SD card (first SD card slot)

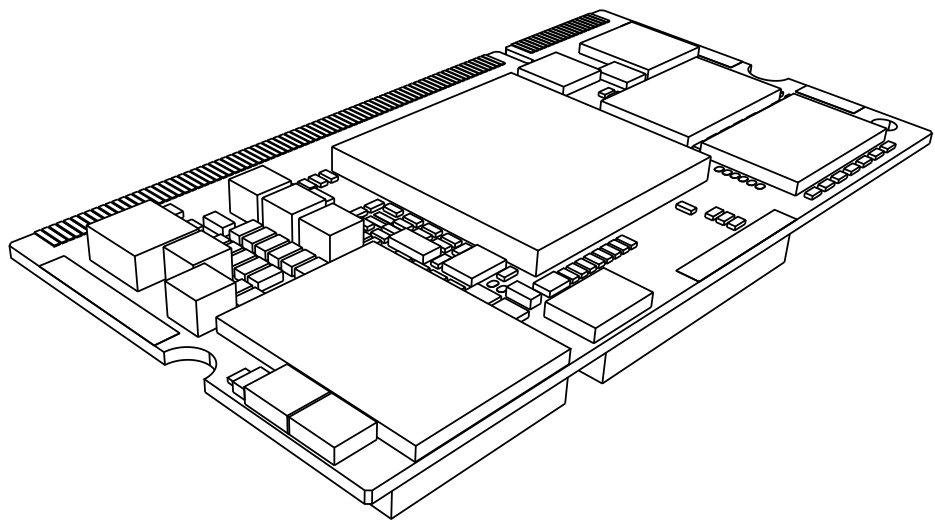

Figure 4-8: CPU Modul

*THIS PAGE INTENTIONALLY BLANK.*

**4.10 NFC - Reader** For the processing of contactless media ISO 14443 A or B, the device has a Smart Card Terminal.

The Smart Card Terminal was developed as a multi-application terminal and offers a maximum of flexibility in the processing of contactless media. The intelligent reader supports the parallel use of different smart card standards. The reader automatically recognizes the card standard when presenting the card. Additional Smart Card standards can be added through a software download and a corresponding SAM extension in most cases.

The terminal has a total of 2 ISO 7816 SAM slots.

Two of the slots are accessible from the outside. To access the additional two SAM slots, the device must be opened.

**4.10.1 Cards Standards**

- MIFARE Classic 1K/4K,
- MIFARE Plus 2K/4K S/X
- MIFARE DESfire EVO/EV1
- MIFARE Ultralight
- Smart MX
- Innovision jewel
- NFC Smart-Card Emulation (passiv)

**4.10.2 eTicketing Standards**

- VDV-KA
- custom standard
- Scheidt & Bachmann Smart Card Standard

*THIS PAGE INTENTIONALLY BLANK.*

## 4.11 Magnetic Stripe Reader

The MT|60 is equipped with a reader to read ISO 7811 magnetic cards with three-lane side strips according to ISO 7811.

The card reader is integrated in the case of the MT|60 and allows a easy and quick reading of the magnetic strip.

### 4.11.1 Technical Specifications

- Magnetic Card Standard: ISO 7811, ISO 7813
- Reading Speed: 7 - 250 cm/s

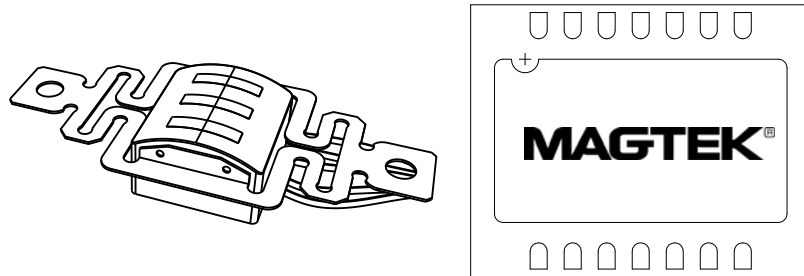

Figure 4-9: Magnetic stripe reader module and magnetic head

*THIS PAGE INTENTIONALLY BLANK.*

## 4.12 Commu- nication Modules

The MT|60 has the following communication modules:

- Bluetooth
- WiFi
- Mobile
- USB

### 4.12.1 Bluetooth

The integrated Bluetooth v3.0 EDR interface includes: A2DP (Advanced Audio Distribution Profile), HSP (Headset Profile) and HDP (Health Device Profile) in addition to the normal Bluetooth connectivity.

### 4.12.2 WiFi

The integrated WiFi interface interface complies with the standard IEEE802.11 a/b/g/n.

### 4.12.3 Mobile

The MT|60 supports the following wireless data connectivity standards:

- GPRS
- EDGE
- UMTS
- HSDPA oder HSPA+

The device has an externally accessible slot for a micro-SIM card.

### 4.12.4 USB

The device is equipped with a micro USB 2.0 interface  
USB OTG (USB On-The-Go).

### 4.12.5 GPS (optional)

The MT|60 can optionally be equipped with GPS.

*THIS PAGE INTENTIONALLY BLANK.*



## 4.13 Protective Cover

The protective cover improves the drop resistance of the MT-60.

The cover is an integral part of the MT-60 and can not be removed without tools.



***In some countries it is not allowed to operate the MT-60 without the protective cover to comply with the FCC guidelines.***

The device remains fully usable with the protective cover on.

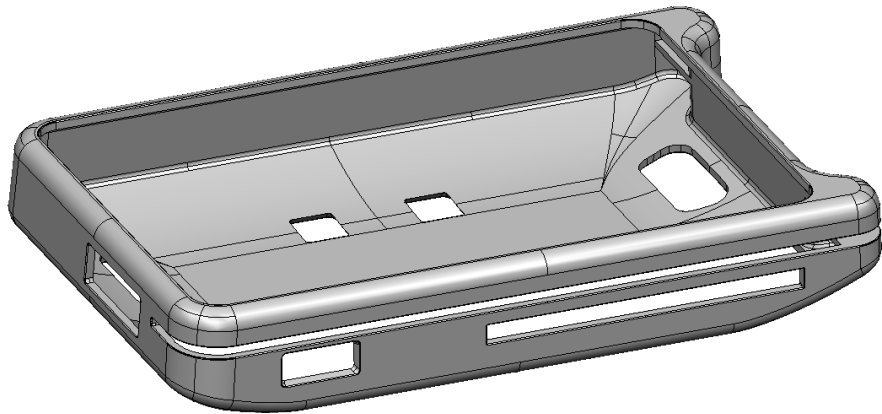

**Figure 4-10:** Protective Cover

*THIS PAGE INTENTIONALLY BLANK.*

# Chapter 5 Commissioning

- For the first commissioning, the following steps are necessary
- Inserting a micro SIM card (see Chapter 5.1)
- Inserting the SAM card/s for the Smart Card Reader (see Chapter 5.1)
- Insert a microSD card (see Chapter 5.1)
- Inserting the battery (see Chapter 5.2)
- Charging the battery (see Chapter 5.3)
- Inserting a paper roll (see Chapter 5.4)

## 5.1 Insert SIM, SAM, and micro SD Card

To insert a micro SIM, -SAM - or a micro SD card, proceed as follows:

- Open the rubber covers of the to be equipped card slot.
- Place the desired card into the appropriate card slot. (see Fig. 5-1)



**All card slots have a spring mechanism that audible and tactile snaps into place when the inserted card is properly positioned**

**To remove a card, push the card a little further into the card slot until an audible and tactile trigger of the spring mechanism to be heard.**

**When you release the card now, it is automatically pushed out by the spring mechanism.**

**This makes it possible to easily remove the card now.**

- Close the rubber covers of all card slots.

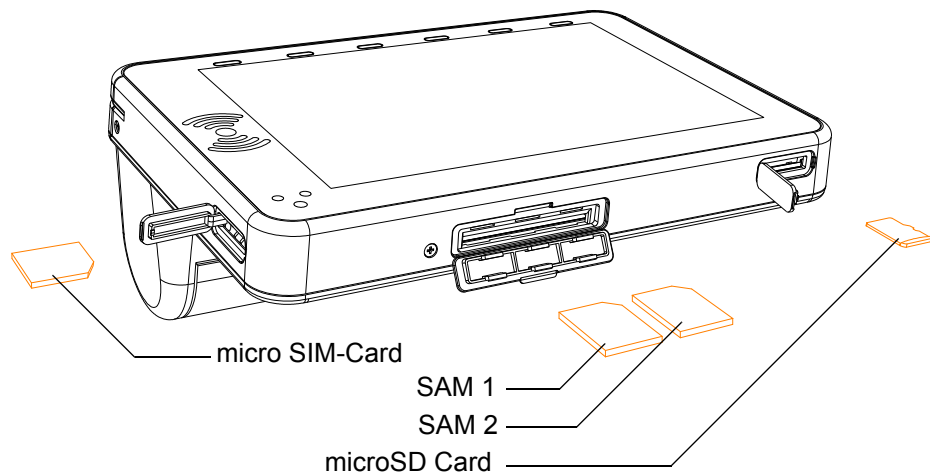

**Figure 5-1:** Insert SIM, SAM and micro SD card

## 5.2 Insert battery

To replace the battery, proceed as follows:.

- Insert the battery to the guiding rails and slide it over the guiding rails as far until the battery snaps into place

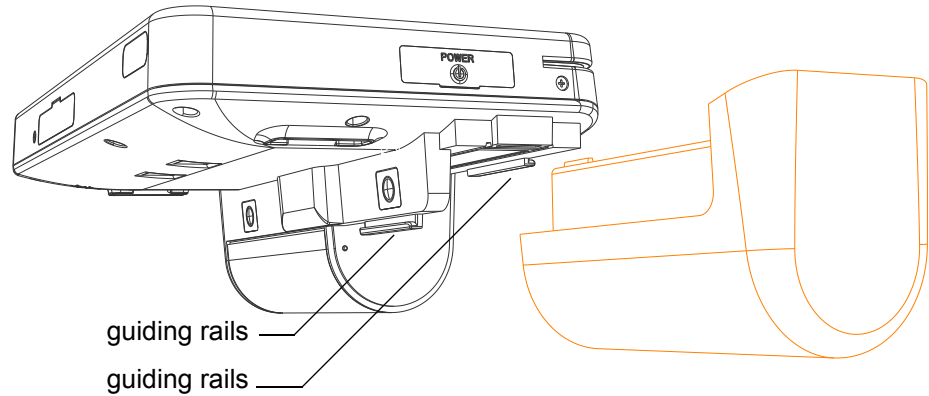

Figure 5-2: Installing the Battery step 1

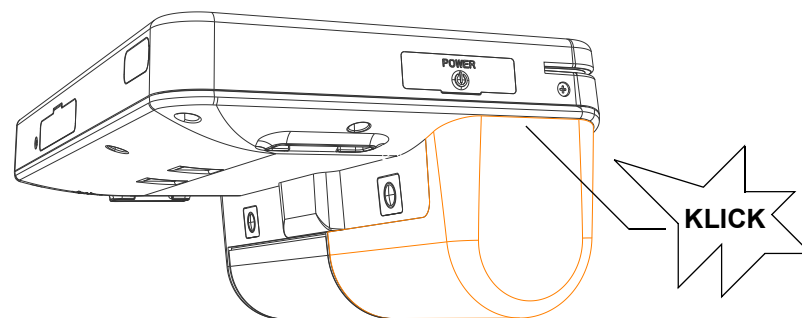

Figure 5-3: Installing the Battery step 2

### 5.3 Recharge battery

The battery can be charged in two ways. At one via the contacts on the bottom of the unit. For this purpose, the device is placed on a charging station (cradle).

To charge the battery via the charging socket, proceed as follows.

- Open the rubber covers, under which the charging socket is located. (see Fig. 5-4)
- Plug the power supply cord into the charging socket.

**Please use exclusively the charging options provided by Scheidt & Bachmann (power supply and Cradle).**



**If using, power supplies do not meet the specifications, the unit may be damaged.**

- When the battery is fully charged, disconnect the charger cable and close the rubber cover.



The unit can not be loaded via the micro USB connector.

The micro USB connector is used exclusively for data exchange.

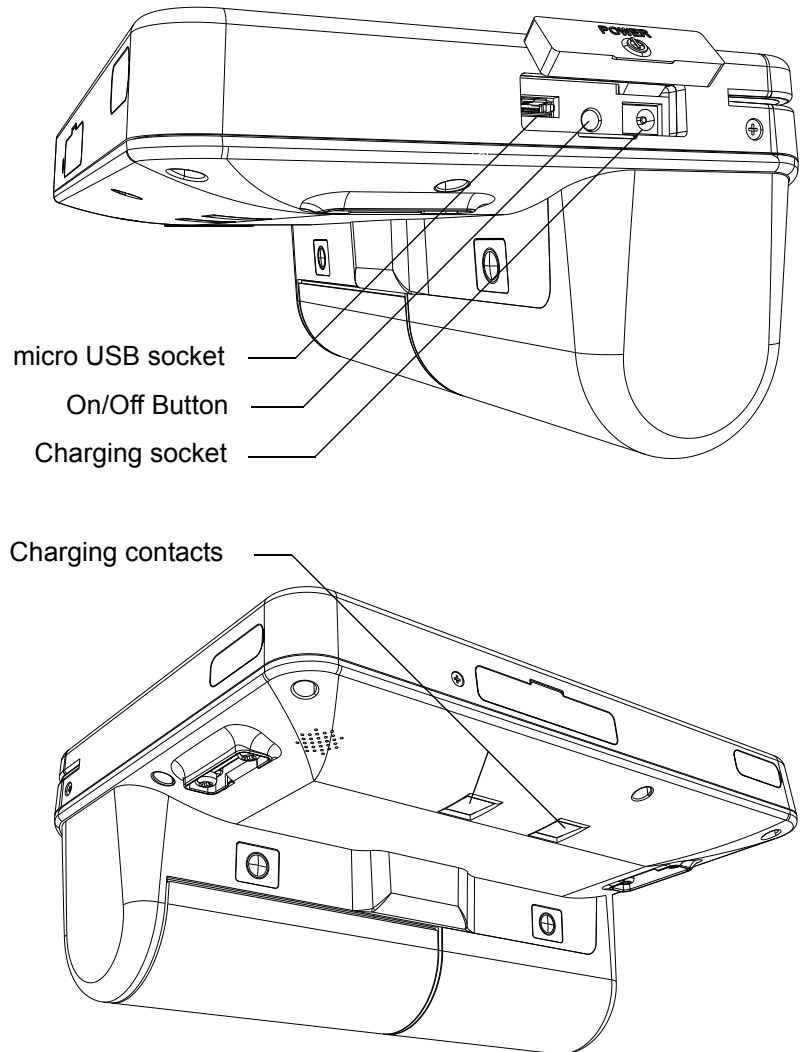
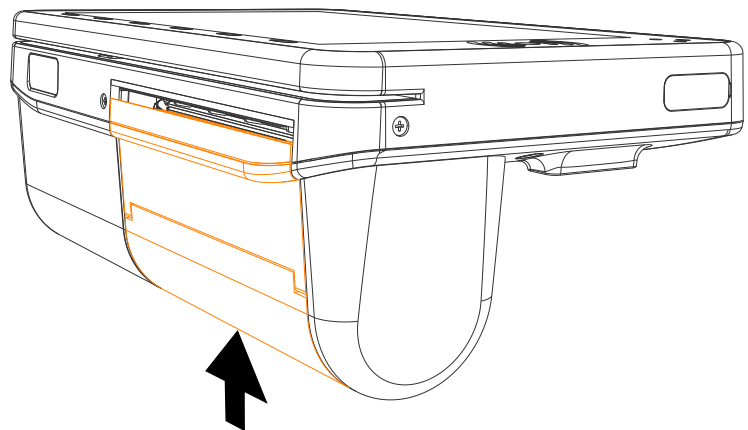

**Figure 5-4:** micro USB, On/Off Button, Charging socket, Charging contacts

## 5.4 Insert Paper

To load the paper, proceed as follows.

- Press from below against the paper tray cover until the upper part of the paper tray cover bounces off by a few millimeters to the front. The paper tray is now unlocked.



**Figure 5-5:** Loading Paper Step 1

- Next step is to drag the paper cover on the top edge to the rear. Now the paper tray cover can be folded down.

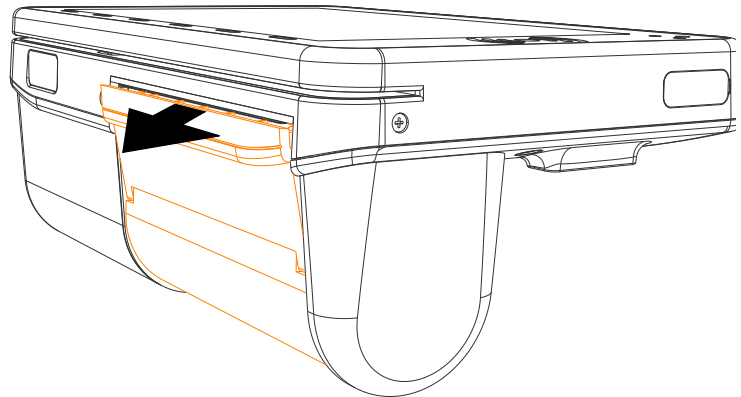

**Figure 5-6:** Loading Paper Step 2

- Insert the correct paper roll into the designated indentation in the paper tray cover. Roll the paper from the roll as far that the paper protrudes a few centimeters out of the printer after loading the paper

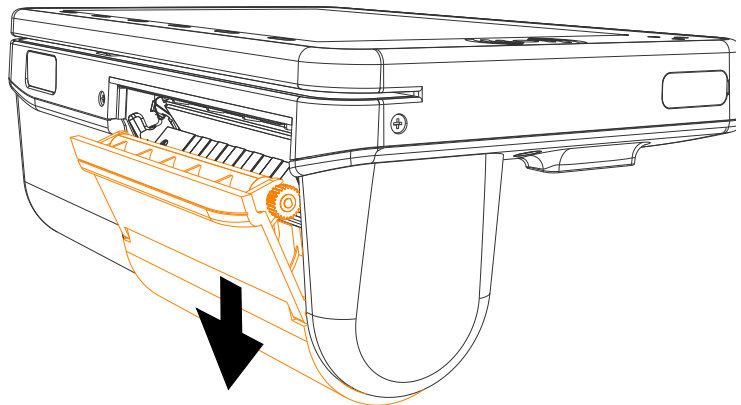

**Figure 5-7:** Loading Paper Step 3

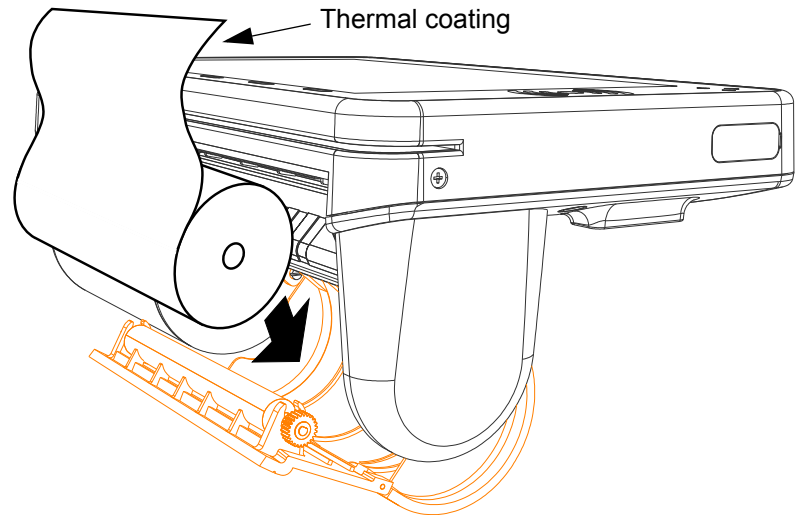

Figure 5-8: Loading Paper Step 4



***The thermo sensitive side of the paper faces toward the printer***

- Close the paper tray cover by pressing below against the cover until the top of the paper tray cover snaps into place.

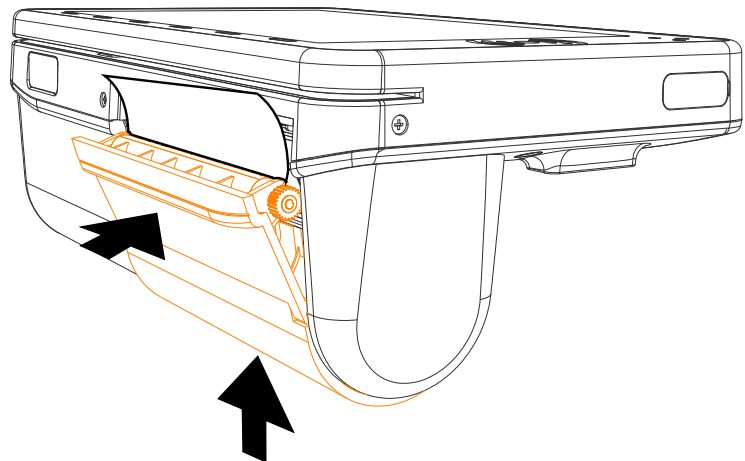
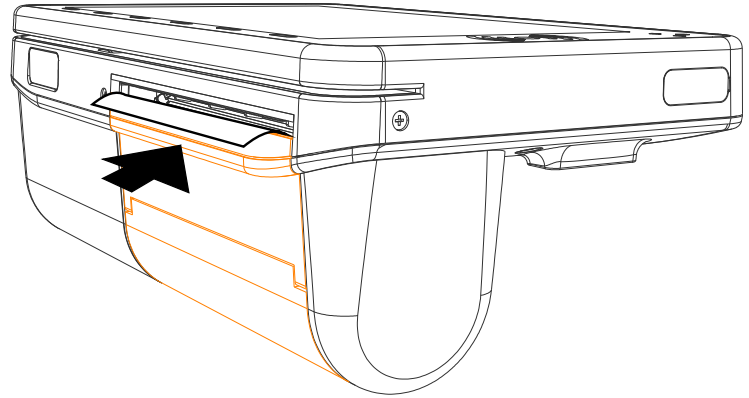

Figure 5-9: Loading Paper Step 5

- To lock the paper tray cover, press against the upper edge of the paper tray cover until it is completely latched and locked.

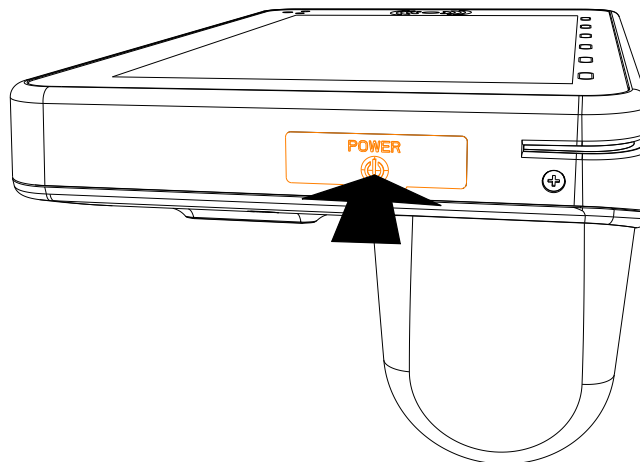

**Figure 5-10:** Loading Paper Step 6

## 5.5 Switch On/Off

Turning on and off of the MT|60 is done via the centrally disposed on/off switch. To turn on the MT|60, press the switch for 2-3 seconds.

To turn off the MT|60 press the on/off switch for a longer time. However, the switching process needs to be confirmed by an additional display dialog.



**Figure 5-11:** On/Off switch

## 5.6 First Start

In the delivery state or after resetting to factory settings, the MT|60 is equipped with the standard components of the Android operating system and a demo application to test the operation of the Barcode Imager, the smart card reader, the magnetic stripe reader and the printer. For correct operation, the following settings should be checked and adjusted on first use:

- Regional Settings
- Time and Time Zone



## Chapter 6 Explanation of terms

In the context with manuals from Scheidt & Bachmann many terms and abbreviations are used. Some terms are defined in industry standard, others are specific to the application (e.g. Networking and telecommunications terms, etc.), others are specifically defined by Scheidt & Bachmann.



**All listed items are exclusively associated with products of Scheidt & Bachmann. Not all terms are valid for the product that is described in this manual.**

A	
A	Ampere
B	
Bluetooth	Radio-based data transmission standard
C	
CE	Communauté Européenne - With the CE marking, the manufacturer declares distributor or EU representative in accordance with EU Regulation 765/2008, "that the product meets the applicable requirements set out in the "Community harmonization legislation providing" providing for its affixing
CPU	<u>C</u> entral <u>P</u> rocessing <u>U</u> nit
D	
DC	<u>D</u> irect <u>C</u> urrent
E	
EDGE	Enhanced Data Rates for mobile networks
EMC	EMC electromagnetic compatibility The EMC refers to a usually desirable state that technical devices do not interfere with each other disruptive due to unwanted electrical or electromagnetic effects.
EN	The European Standards (EN) are rules that have been ratified by one of the three European Committee for Standardization.
Error Code	Also referred to as an error message. Error information is available on the Customer Display, Service Terminal Display, or printed report concerning a TVM fault or malfunction.
ESD	The <u>E</u> lectrostatic <u>D</u> ischarge symbol indicates the potential for serious damage to the printed circuit boards or other Electrostatic Discharge (ESD) sensitive devices in the machine.

Ethernet Card                      The Ethernet Card is installed in the main computer. It provides a communications interface between the TVM and an ethernet Local Area Network (LAN).

**F**

FCC                                      Federal Communications Commission - The FCC is (amateur radio, etc.) as well as responsible regulatory authority for communications devices such as radios, televisions and computers for various wireless services. It checks the devices for compatibility with the own and other standards.

Flash Card                              The flash card is a storage module (PCMCIA) that is used for TVM initialization and data storage.

**G**

Gorilla Glass                              Gorilla Glass is a protected wordmark for a thin chemically toughened glass from the group of the US manufacturer Corning of aluminosilicate glasses

GPS                                        Global Positioning System - radio-based data transmission standard

GPRS                                        General Packet Radio Service

**H**

HSDPA                                      High Speed Downlink Packet Access

Hotkey                                      Quick selection button that can be individually assigned with a function.

**I**

IC    Industry Canada - Telecommunications Appliances accreditation standard

IP    International Protectioncodes - The IP protection specify the degree of protection of the housing against contact, foreign bodies and water.

ID    Identification Number

IEC    International Electro-technical Commission

**K**

**L**

LCD                                        Liquid Crystal Display; see LCD Display.

LED                                        Light Emitting Diode

LCD Display                              Part of the Customer Display on the TVM.

Light Sensor                              A light sensor is a electronic component that converting light, using the photoelectric effect, in an electrical signal or shows a electrical resistance depending of the incident radiation

**M**

MT 60	Mobil Terminal 60 = Characteristics of the device
Mobile	Radio-based data transmission standard
N	
NFC	Near Field Communication - Radio-based data transmission standard
P	
PIN	<u>P</u> ersonal <u>I</u> dentification <u>N</u> umber
R	
RoHS	Restriction of Hazardous Substances - Restriction of the use of certain hazardous substances in electrical and electronic equipment
R&TTE	Guidelines for radio equipment and Telecommunication Terminal Equipment
S	
SIM-Karte	Subscriber Identity Module - The SIM card is a card that is plugged into a mobile phone and is used to identify the user within the network
SAM	Secure Access Module
SD Karte	Secure Digital Memory Card - Data Storage Device
S & B	Scheidt & Bachmann
T	
Touch Screen	The Touch Screen is part of the Customer Display. It select inputs by pressing on the screen.
U	
UL	Underwriters Laboratories - An organization tests products, components, materials and systems, whether they meet specific requirements. If this is the case, these products may show the chargeable UL Mark, as long as they meet the prescribed standards
UMTS	Universal Mobile Telecommunications System
USB	Universal Serial Bus - Contact-based communication standard
V	
W	
WEEE	Waste of Electrical and Electronic Equipment - The WEEE Directive, the EU Directive 2002/96 / EC to reduce the increasing amount of electronic waste from disused electrical and electronic equipment
WLAN	Wireless Local Area Network - Radio-based data transmission standard

*THIS PAGE INTENTIONALLY BLANK.*