



PMS/C

ChipCoin® Processing

Systems for Car Parks and Leisure Centres

- Service Manual -

© 2004 by Scheidt & Bachmann GmbH, Mönchengladbach (Germany)
All rights reserved. Subject to alterations. Some illustrations and descriptions may also include special options.

Contents

Page

1.	Introduction	2
1.1.	Block diagram	2
2.	Coin feeder	3
2.1.	Entry	3
2.1.1.	Function	3
2.2.	Exit	4
2.2.1.	Function	4
2.3.	Automatic Pay Station	5
2.3.1.	Function	5
2.4.	Maintenance and service.....	6
2.4.1.	Outside	6
2.4.2.	Inside	7
3.	Entry hopper.....	8
3.1.	View	8
3.2.	Maintenance and service.....	9
4.	ChipCoin interface.....	10
4.1.	View / connections.....	10
5.	PIT Base station	11
5.1.	View / connections.....	12
6.	Item numbers	12

1. Introduction

At an **entry** the coin feeder is located directly in front of the hopper. In case of a ChipCoin request the coin goes from the hopper to the coin feeder, where it is guided through the coin channel via stopper and reject magnets and coded and read by an installed antenna coil.

At an **exit** the ChipCoin inserted by the customer goes directly into the coin feeder. Here it is read via the antenna coil and, when found to be valid, is moved on to the collector receptacle; the gate opens. ChipCoins without exit authorisation are returned via a reject mechanism to be removed by the customer.

At an **automatic pay machine** the ChipCoin inserted by the customer likewise goes directly to the coin feeder. It is read via the antenna coil and "parked" there as long as necessary until the customer has paid the fee calculated. Simultaneous to that the insertion aperture of the coin channel (shutter) closes in order to prevent insertion of coins into the coin feeder.

Due to the different demands (with shutter, without shutter, different coin inlet) different coin feeders are used for entrance, exit and automatic teller.

All versions are based on identical coin channels (black coin feeder casing) which are varyingly fitted with magnets, reflex couplers and mechanical components.

First of all the different versions and their functional operation will be explained.

Maintenance tips will be given on the basis of a fully outfitted coin channel.

1.1. Block diagram

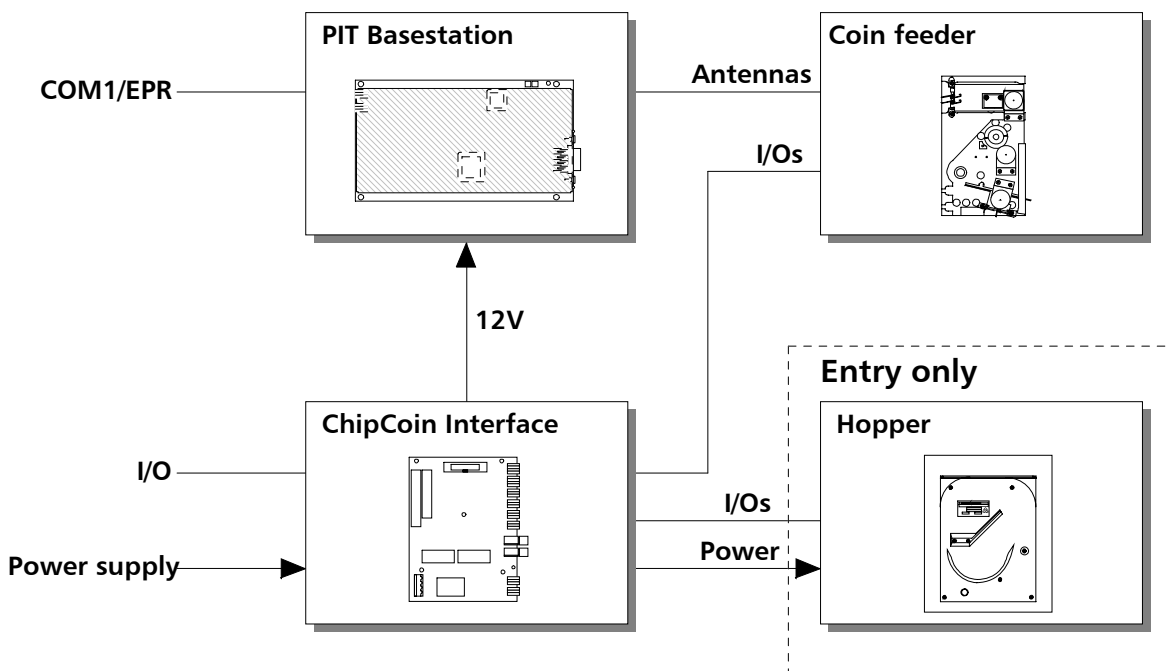

2. Coin feeder

2.1. Entry

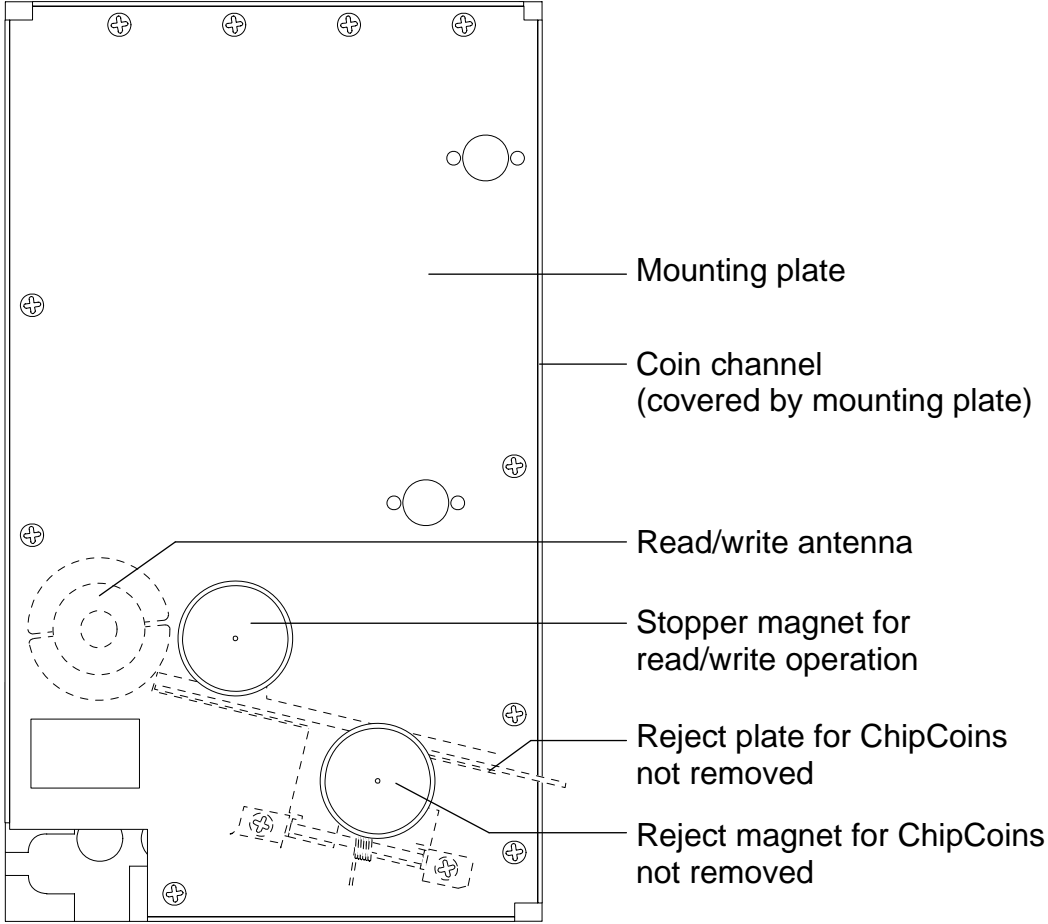

2.1.1. Function

As soon as a vehicle drives over the loop, the ChipCoin, which has already been positioned by the stopper magnet in front of the read/write antenna, is coded.

After pressing the ChipCoin request button the stopper magnet is pulled tight and the ChipCoin is thereby released for output.

If the ChipCoin cannot be coded, the stopper magnet and the reject magnet pull tight and the ChipCoin falls into the collector receptacle.

If the ChipCoin is not removed within a predefined period of time, the stopper magnet pulls tight and the coin is dropped into the collector receptacle.

After removing the coded ChipCoin a new ChipCoin is brought into position in front of the read/write antenna.

© 2004 by Scheidt & Bachmann GmbH, Mönchengladbach (Germany)
 All rights reserved. Subject to alterations. Some illustrations and descriptions may also include special options.

2.2. Exit

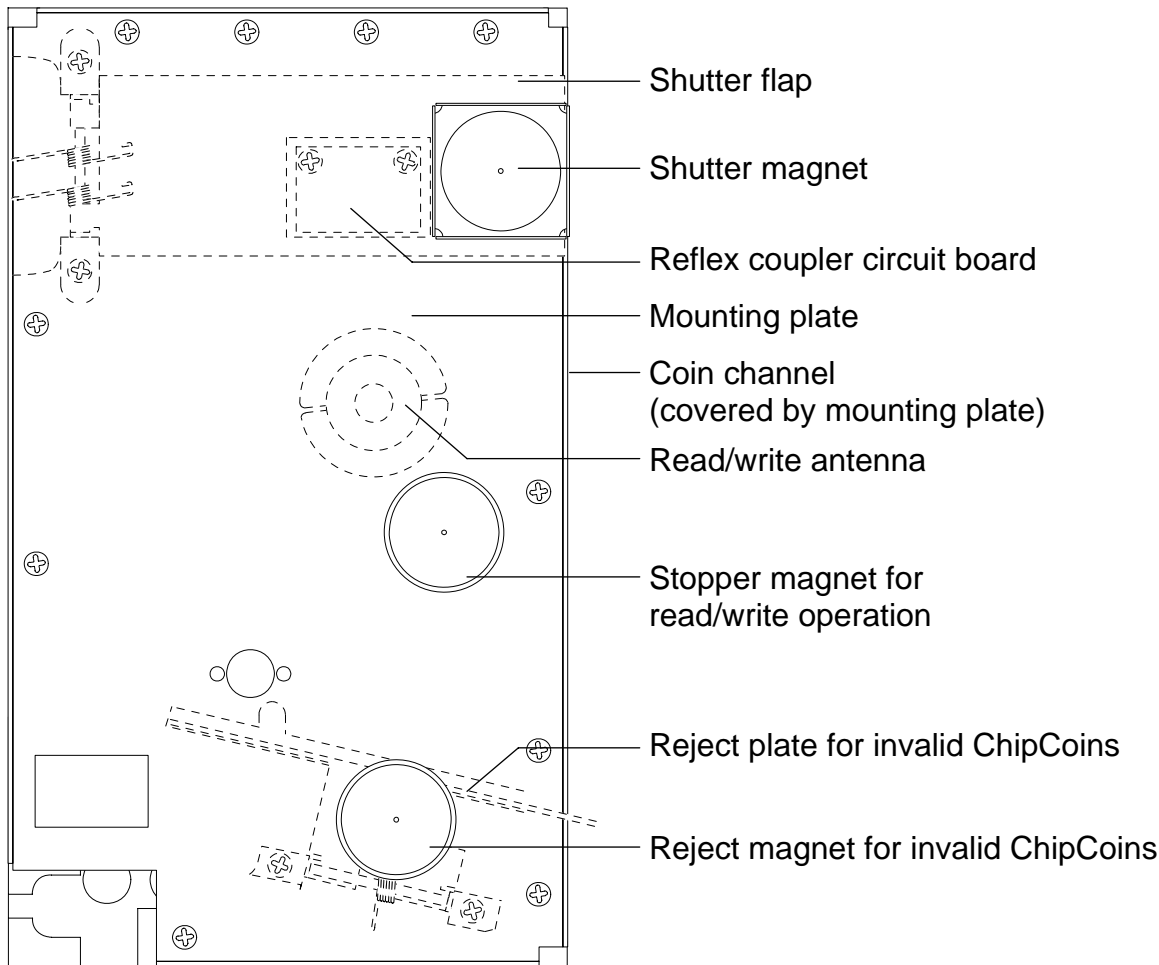

2.2.1. Function

The shutter releases the ChipCoin insert chute if a vehicle is on the loop. In this way insertion of foreign matter by pedestrians (vandalism) is prevented.

In standard position the shutter is closed, the stopper magnet blocks the ChipCoin and the rejector plate stands in the "Reject coin" position (output to the front).

If the loop is driven over, the shutter is opened. (Magnet pulls tight). The ChipCoin is inserted and is blocked at the read/write antenna by the stopper magnet. The ChipCoin is analysed.

If it entitles the holder to exit, the stopper magnet and the reject magnet pull tight. The ChipCoin falls into the exit collector receptacle and the gate is opened.

If the ChipCoin is invalid (eg, the period of grace is exceeded; supplemental payment) the stopper magnet pulls tight and the ChipCoin is outputted to the front via the reject plate. The gate does not open. The reason for this is shown to the customer on the display.

2.3. Automatic Pay Station

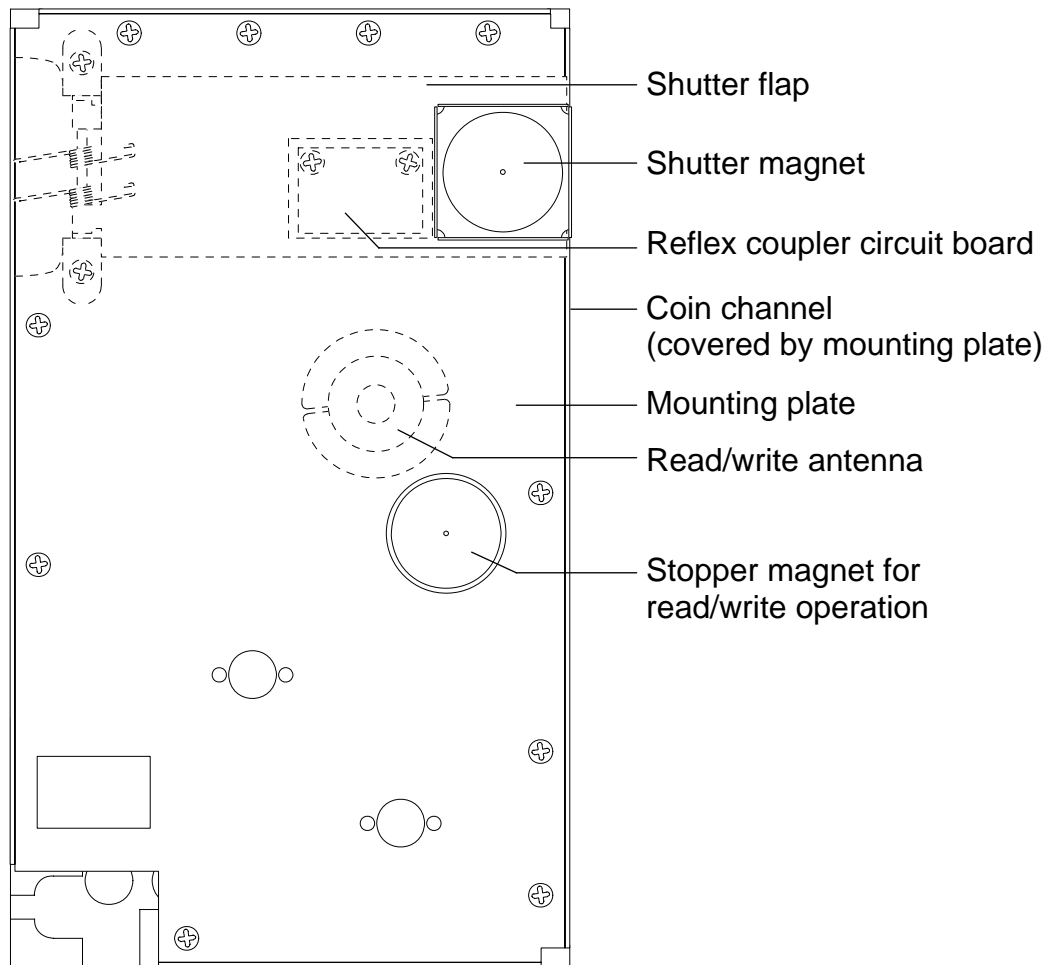

2.3.1. Function

At the automatic teller the shutter closes upon insertion of a ChipCoin and thereby prevents the customer from inserting coins into the coin feeder.

In standard condition the shutter is opened and the stopper magnet blocks the ChipCoin.

If the customer has inserted the ChipCoin for analysis, this is recognised by the reflex coupler and the shutter is closed (the magnet drops down). The ChipCoin is positioned in front of the read/write antenna by the stopper magnet. The amount to be paid is determined and displayed.

When the payment operation is completed, the authorisation to exit is coded on the ChipCoin and the stopper magnet is briefly pulled tight. The ChipCoin falls into the return change cup for removal.

Suggestion:

In order to avoid blockage/disturbance by foreign matter (e.g., coins), the stopper magnet at regular intervals pulls tight briefly so that such items are diverted down into the return change cup.

2.4. Maintenance and service

2.4.1. Outside

The small number of movable parts reduces maintenance expense to the coin feeder to a minor level. The following suggestions should, however, be heeded in order to ensure permanent faultfree operations.

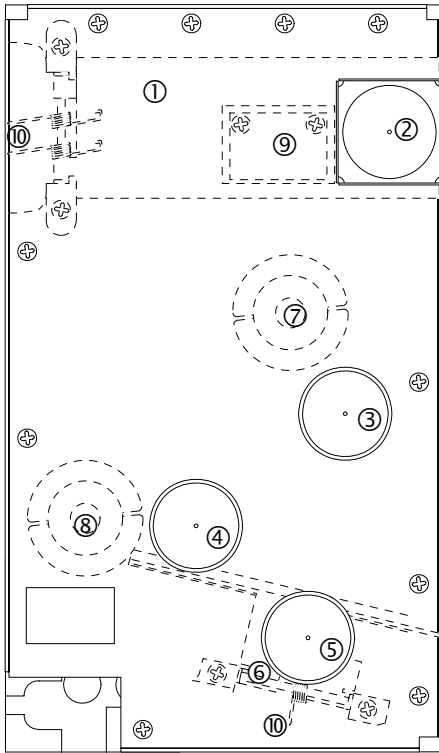

- ① Shutter plate
- ② Shutter magnet
- ③ Stopper magnet (exit, automatic pay station)
- ④ Stopper magnet (entry)
- ⑤ Reject magnet
- ⑥ Reject plate
- ⑦ Read/write antenna (exit, automatic pay station)
- ⑧ Read/write antenna (entry)
- ⑨ Reflex coupler circuit board
- ⑩ Springs for shutter, rejector plate

- The entire coin feeder should be checked on both inside and outside for dirt and, if necessary, should be cleaned. Be careful, in doing so, of the shutter and rejecter magnet mechanism (②, ⑤).
- In case of serious dirt accumulation an air pump can be used for cleaning.
- Check for the smooth working of the shutter plate (①) and the reject plate (⑥). Only the spring tension (⑩) should be allowed to show any perceptible resistance.
- Check for tight fit of the read/write antenna (⑦, ⑧).

2.4.2. Inside

2.4.2.1. Cover removal

For removal of the cover the coin feeder should be taken out of its bracket.

Coin channel and cover are held together by a bayonet catch. After pushing the cover upwards it can be removed.

Push cover upwards

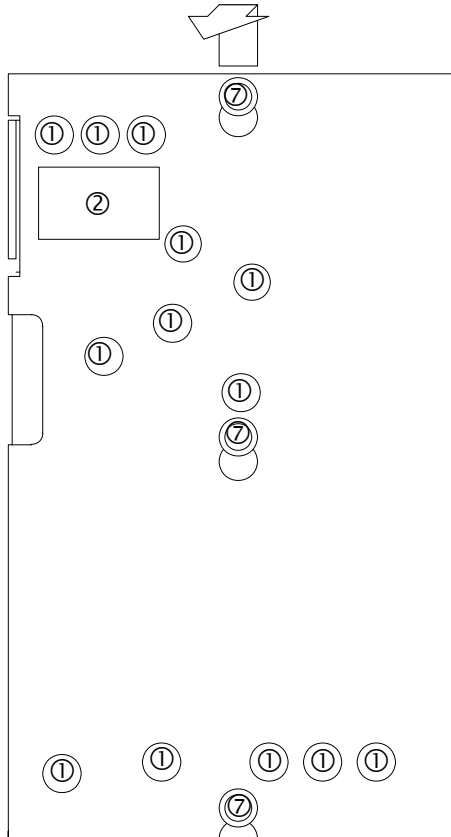

Coin feeder without the cover

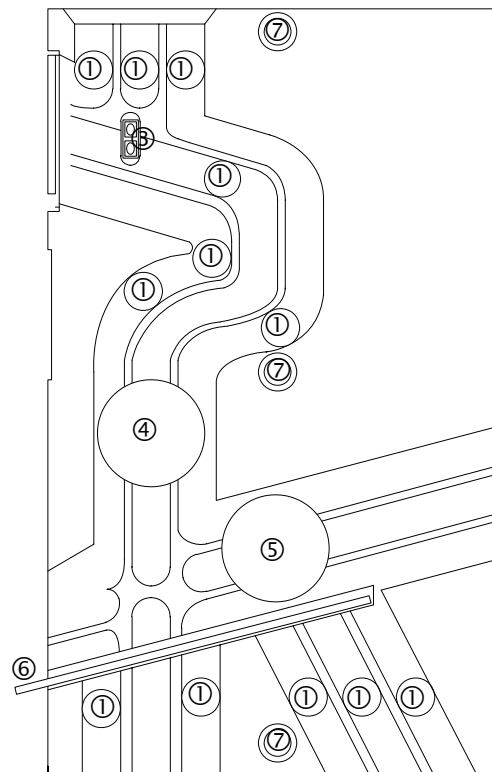

- ① Condensation openings
- ② Reflecting sticker for reflect coupler
- ⑦ Bayonet catch

- ③ Reflex coupler
- ④ Stopper magnet (exit, automatic pay station)
- ⑤ Stopper magnet (entry)
- ⑥ Rejector plate

- Check the sticker (②) for dirt. It must have a light-coloured reflecting surface.
- Check the reflex coupler (③) for dirt.
- For cleaning the coin channel use an air pump, a brush or a soft rag.
- Check to see that the stopper magnets (④,⑤) work smoothly. They must let themselves be pressed in easily upon pressure from the encapsulated spiral spring. Under no circumstances may they be hard to move, nor should they stick tight.

3. Entry hopper

The entrance hopper stores the ChipCoins and conveys them to the coin feeder. In order to increase its capacity and to make refilling easier, a funnel has been mounted on top of the hopper. In order to check the supply of ChipCoins, the funnel has been provided with viewing holes.

Control and voltage supply occur via a connection to the ChipCoin interface.

Coin output occurs via a chain. In order to ensure that the coins reach the right properly start-position for transport via the chain, with every movement of the chain there occurs additionally the movement of one of the slides driven by an eccentric. Both the chain and the slide are driven by the same motor.

3.1. View

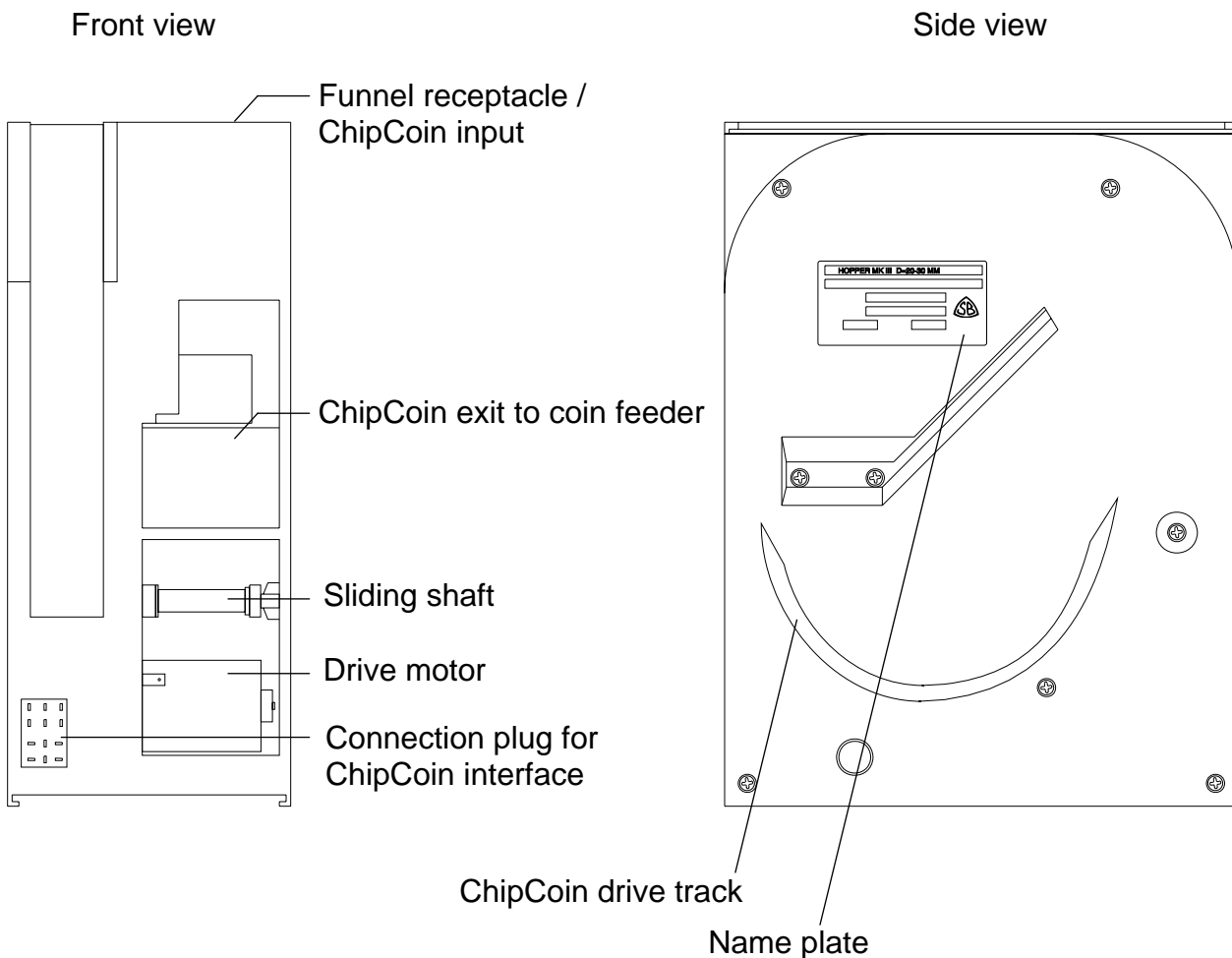

© 2004 by Scheidt & Bachmann GmbH, Mönchengladbach (Germany)
All rights reserved. Subject to alterations. Some illustrations and descriptions may also include special options.

3.2. Maintenance and service

The hopper is **maintenance-free**. Should it ever occur that, despite plentiful supply of coins, no ChipCoin is outputted, then possibly a jam may have occurred.

Check to see if the hopper upon a ChipCoin request makes a short movement. If this is the case and no jam obtains in the coin feeder, then take the hopper out and empty it. Jams can normally be eliminated by shaking the hopper. You will hear if the ChipCoin releases. Then fill the hopper again and put it back in. Turn the entrance on again and check its functioning.



Never work on the hopper with the current turned on. First turn the entrance off and then remove the plug from the hopper.

4. ChipCoin interface

The Chip-Coin interface circuit board assumes control of the stopper, shutter and rejector magnets as well as analysis of information from the reflex coupler and the photoelectric barrier as well as hopper control.

4.1. View / connections

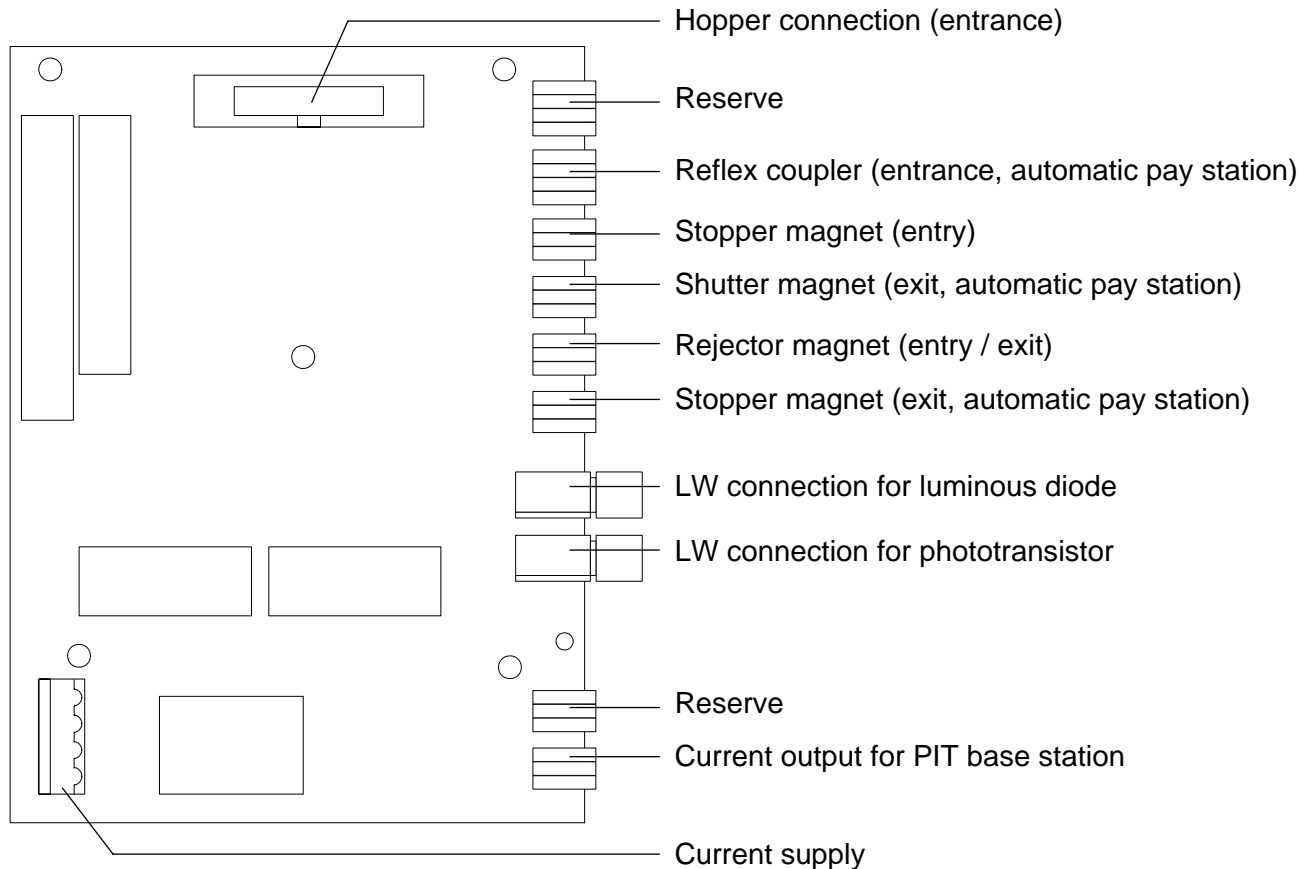

Never work on the circuit board when the current is on. First turn off the device and wait until it has come to a complete rest.

5. PIT Base station

The PIT base station III is the interface for coding and analysis of the ChipCoin cards. It has a serial interface for connection to the single-board computer or the PMK computer as well as having two antenna connections.



This equipment has been tested and found to comply with the limits for a Class B digital device, pursuant to Part 15 of the FCC Rules. These limits are designed to provide reasonable protection against harmful interference in a residential installation. This equipment generates, uses and can radiate radio frequency energy and, if not installed and used in accordance with the instructions, may cause harmful interference to radio communications. However, there is no guarantee that interference will not occur in a particular installation. If this equipment does cause harmful interference to radio or television reception, which can be determined by turning the equipment off and on, the user is encouraged to try to correct the interference by one or more of the following measures:

- Reorient or relocate the receiving antenna.
- Increase the separation between the equipment and receiver.
- Connect the equipment into an outlet on a circuit different from that to which the receiver is connected.
- Consult the dealer or an experienced radio/TV technician for help.

Changes and modifications not expressly approved by Scheidt & Bachmann can void the user's authority to operate the equipment.

5.1. View / connections

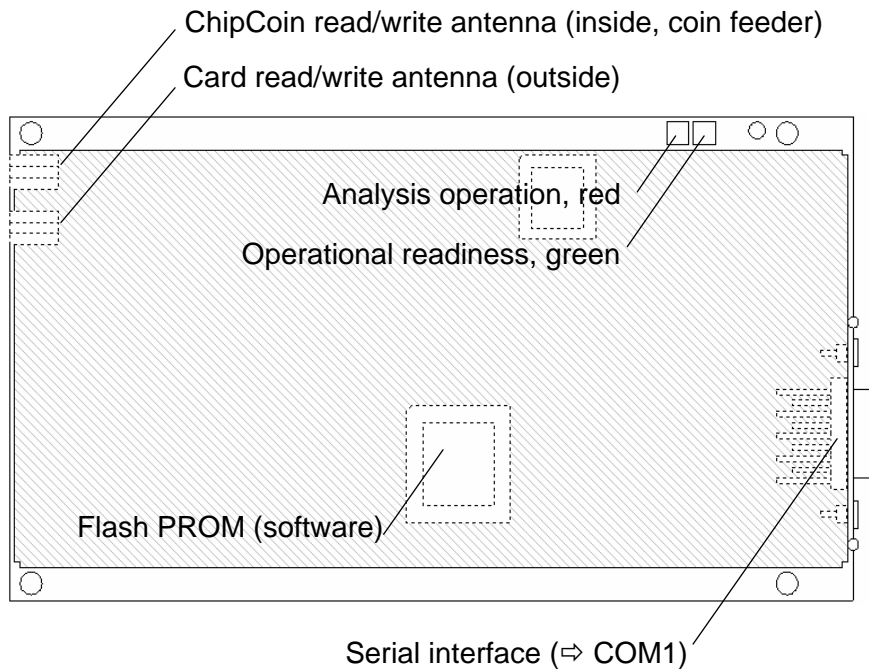

Never work on the circuit board when the current is on. First turn off the device and wait until it has come to a complete rest.

6. Item numbers

PIT Base station III.....	04 19275
ChipCoin Interface.....	04 18306
Entry hopper (bulk coin store)	04 18112
Entry coin feeder	04 17845
Exit coin feeder	04 17844
Automatic Pay Station feeder.....	04 18117

© 2004 by Scheidt & Bachmann GmbH, Mönchengladbach (Germany)
All rights reserved. Subject to alterations. Some illustrations and descriptions may also include special options.