



# FCC RF Test Report

**APPLICANT** : Lenovo (Shanghai) Electronics Technology Co., Ltd.  
**EQUIPMENT** : Portable Tablet Computer  
**BRAND NAME** : Lenovo  
**MODEL NAME** : Lenovo YT3-X50M  
**FCC ID** : O57YT3X50M  
**STANDARD** : FCC Part 15 Subpart C §15.247  
**CLASSIFICATION** : (DTS) Digital Transmission System

The product was received on Jul. 03, 2015 and testing was completed on Aug. 13, 2015. We, SPORTON INTERNATIONAL (KUNSHAN) INC., would like to declare that the tested sample has been evaluated in accordance with the test procedures and has been in compliance with the applicable technical standards.

The test results in this report apply exclusively to the tested model / sample. Without written approval of SPORTON INTERNATIONAL (KUNSHAN) INC., the test report shall not be reproduced except in full.

Reviewed by: Joseph Lin / Supervisor

Approved by: Jones Tsai / Manager



**SPORTON INTERNATIONAL (KUNSHAN) INC.**  
**No. 3-2, PingXiang Road, Kunshan, Jiangsu Province, P. R. China**



# TABLE OF CONTENTS

**REVISION HISTORY..... 3**

**SUMMARY OF TEST RESULT ..... 4**

**1. GENERAL DESCRIPTION ..... 5**

    1.1 Applicant ..... 5

    1.2 Manufacturer ..... 5

    1.3 Product Feature of Equipment Under Test..... 5

    1.4 Product Specification subjective to this standard ..... 5

    1.5 Modification of EUT ..... 6

    1.6 Testing Location ..... 6

    1.7 Applicable Standards..... 6

    1.8 Component List..... 7

**2. TEST CONFIGURATION OF EQUIPMENT UNDER TEST ..... 8**

    2.1 Carrier Frequency Channel ..... 8

    2.2 Pre-Scanned RF Power..... 9

    2.3 Test Mode..... 10

    2.4 Connection Diagram of Test System..... 11

    2.5 Support Unit used in test configuration and system ..... 12

    2.6 EUT Operation Test Setup ..... 12

    2.7 Measurement Results Explanation Example..... 12

**3. TEST RESULT..... 13**

    3.1 6dB Bandwidth Measurement ..... 13

    3.2 Output Power Measurement..... 15

    3.3 Power Spectral Density Measurement ..... 16

    3.4 Conducted Band Edges and Spurious Emission Measurement ..... 18

    3.5 Radiated Band Edges and Spurious Emission Measurement ..... 28

    3.6 AC Conducted Emission Measurement..... 32

    3.7 Antenna Requirements..... 36

**4. LIST OF MEASURING EQUIPMENT ..... 37**

**5. UNCERTAINTY OF EVALUATION ..... 38**

**APPENDIX A. CONDUCTED TEST RESULTS**

**APPENDIX B. RADIATED TEST RESULTS**

**APPENDIX C. SETUP PHOTOGRAPHS**



## REVISION HISTORY

REPORT NO.	VERSION	DESCRIPTION	ISSUED DATE
FR570302C	Rev. 01	Initial issue of report	Sep. 10, 2015



### SUMMARY OF TEST RESULT

Report Section	FCC Rule	Description	Limit	Result	Remark
3.1	15.247(a)(2)	6dB Bandwidth	$\geq 0.5\text{MHz}$	Pass	-
3.2	15.247(b)	Power Output Measurement	$\leq 30\text{dBm}$	Pass	-
3.3	15.247(e)	Power Spectral Density	$\leq 8\text{dBm}/3\text{kHz}$	Pass	-
3.4	15.247(d)	Conducted Band Edges	$\leq 20\text{dBc}$	Pass	-
		Conducted Spurious Emission		Pass	-
3.5	15.247(d)	Radiated Band Edges and Radiated Spurious Emission	15.209(a) & 15.247(d)	Pass	Under limit 3.05 dB at 4875.000 MHz
3.6	15.207	AC Conducted Emission	15.207(a)	Pass	Under limit 12.51 dB at 0.430 MHz
3.7	15.203 & 15.247(b)	Antenna Requirement	N/A	Pass	-



# 1. General Description

## 1.1 Applicant

**Lenovo (Shanghai) Electronics Technology Co., Ltd.**  
 No. 68 Building, 199 Fenju Road, Wai Gao Qiao FTZ, Shanghai, China

## 1.2 Manufacturer

**Lenovo PC HK Limited**  
 23/F, Lincoln House, Taikoo Place 979 King's Road, Quarry Bay, Hong Kong

## 1.3 Product Feature of Equipment Under Test

Product Feature	
<b>Equipment</b>	Portable Tablet Computer
<b>Brand Name</b>	Lenovo
<b>Model Name</b>	Lenovo YT3-X50M
<b>FCC ID</b>	O57YT3X50M
<b>EUT supports Radios application</b>	GSM/GPRS/EGPRS/WCDMA/HSPA/DC-HSDPA HSPA+(Downlink Only)/LTE WLAN 2.4GHz 802.11b/g/n HT20/ Bluetooth v3.0 + EDR/Bluetooth v4.0 LE
<b>IMEI Code</b>	Conducted: 867152020026572 Radiated: 867989020027658 Conduction: 867989020027658
<b>HW Version</b>	LLAM510
<b>SW Version</b>	LLA3I16 B01
<b>EUT Stage</b>	Identical Prototype

**Remark:** The above EUT's information was declared by manufacturer. Please refer to the specifications or user's manual for more detailed description.

## 1.4 Product Specification subjective to this standard

Product Specification subjective to this standard	
<b>Tx/Rx Channel Frequency Range</b>	802.11b/g/n : 2412 MHz ~ 2462 MHz
<b>Maximum (Peak) Output Power to Antenna</b>	802.11b : 18.79 dBm (0.0757 W) 802.11g : 22.03 dBm (0.1596 W) 802.11n HT20 : 21.95 dBm (0.1567 W)
<b>Antenna Type</b>	PCB Antenna with gain -0.10 dBi
<b>Type of Modulation</b>	802.11b : DSSS (DBPSK / DQPSK / CCK) 802.11g/n : OFDM (BPSK / QPSK / 16QAM / 64QAM)



### 1.5 Modification of EUT

No modifications are made to the EUT during all test items.

### 1.6 Testing Location

<b>Test Site</b>	SPORTON INTERNATIONAL (SHENZHEN) INC.		
<b>Test Site Location</b>	1F & 2F, Building A, Morning Business Center, No. 4003 ShiGu Rd., Xili Town, Nanshan District, Shenzhen, Guangdong, P. R. China TEL: +86-755-8637-9589 FAX: +86-755-8637-9595		
<b>Test Site No.</b>	<b>Sporton Site No.</b>		
	TH01-SZ		

<b>Test Site</b>	SPORTON INTERNATIONAL (KUNSHAN) INC.		
<b>Test Site Location</b>	No. 3-2, PingXiang Road, Kunshan, Jiangsu Province, P. R. China TEL: +86-0512-5790-0158 FAX: +86-0512-5790-0958		
<b>Test Site No.</b>	<b>Sporton Site No.</b>		<b>FCC Registration No.</b>
	CO01-KS	03CH02-KS	418269

**Note:** The test site complies with ANSI C63.4 2009 requirement.

### 1.7 Applicable Standards

According to the specifications of the manufacturer, the EUT must comply with the requirements of the following standards:

- ♦ FCC Part 15 Subpart C §15.247
- ♦ FCC KDB Publication No. 558074 D01 DTS Meas. Guidance v03r03
- ♦ ANSI C63.10-2013

**Remark:**

1. All test items were verified and recorded according to the standards and without any deviation during the test.
2. FCC permits the use of the 1.5 meter table as an alternative in C63.10-2013 through inquiry tracking number 961829.
3. This EUT has also been tested and complied with the requirements of FCC Part 15, Subpart B, recorded in a separate test report.



### 1.8 Component List

**Note:** There are two types of EUT, the details refer the following table. According to the difference, we evaluate is not affect RF performance, so only choose sample 1 to perform RF test.

Component	Sample 1	Sample 2
CPU	Qualcomm (MSM8909 2AA)	Qualcomm (MSM8909 2AA)
Flash	Samsung (KMQ4Z0013M)	Hynix (H9TQ17ABJTMC)
LCD	AUO (B101EAN02.4)	BOE (TV101WXM-NL0)
Camera	O-FILM (L8865A80 8MP)	O-FILM (L8865A80 8MP)
Motor	HOCHAR (F102730-20Y)	DMEGC (DM-B1003-3H)
Battery	lenovo (Sunwoda) (L15D3K32)	lenovo(Scud) (L15D3K32)



## 2. Test Configuration of Equipment Under Test

The EUT has been associated with peripherals and configuration operated in a manner tended to maximize its emission characteristics in a typical application. Frequency range investigated: conducted emission (150 kHz to 30 MHz) and radiated emission (9 kHz to the 10th harmonic of the highest fundamental frequency or to 40 GHz, whichever is lower). For radiated measurement, pre-scanned in three orthogonal panels, X, Y, Z. The worst cases (X/Z plane) were recorded in this report.

The final configuration from all the combinations and the worst-case data rates were investigated by measuring the maximum power across all the data rates and modulation modes under section 2.2.

Based on the worst configuration found above, the RF power setting is set individually to meet FCC compliance limit for the final conducted and radiated tests shown in section 2.3.

### 2.1 Carrier Frequency Channel

Frequency Band	Channel	Freq. (MHz)	Channel	Freq. (MHz)
2400-2483.5 MHz	1	2412	7	2442
	2	2417	8	2447
	3	2422	9	2452
	4	2427	10	2457
	5	2432	11	2462
	6	2437	-	-





## 2.2 Pre-Scanned RF Power

Preliminary tests were performed in different data rate and data rate associated with the highest power were chosen for full test shown in the following tables.

2.4GHz 802.11b mode				
Data Rate (MHz)	1M bps	2M bps	5.5M bps	11M bps
Peak Power (dBm)	18.79	18.76	18.75	18.78

2.4GHz 802.11g mode								
Data Rate (MHz)	6M bps	9M bps	12M bps	18M bps	24M bps	36M bps	48M bps	54M bps
Peak Power (dBm)	22.03	21.95	22.01	21.94	21.96	21.98	22.00	21.96

2.4GHz 802.11n HT20 mode								
Data Rate (MHz)	MCS0	MCS1	MCS2	MCS3	MCS4	MCS5	MCS6	MCS7
Peak Power (dBm)	21.95	21.75	21.72	21.76	21.72	21.78	21.79	21.83



### 2.3 Test Mode

Final test mode of conducted test items and radiated spurious emissions are considering the modulation and worse data rates from the power table described in section 2.2.

Modulation	Data Rate
802.11b	1 Mbps
802.11g	6 Mbps
802.11n HT20	MCS0

Test Cases	
<b>AC Conducted Emission</b>	Mode 1 : GSM850 Idle + Bluetooth Link + WLAN Link + Earphone + Battery 1 + USB Cable (Charging from Adapter) for Sample 1  Mode 2 : GSM850 Idle + Bluetooth Link + WLAN Link + Earphone + Battery 2 + USB Cable (Charging from Adapter) for Sample 2
<b>Remark:</b>  1. The worst case of conducted emission is mode 1; only the test data of it was reported. 2. For Radiated Test Cases, The tests were performance with Adapter, Battery, Earphone, and USB Cable. 3. All the conducted and radiated test cases were performance with Sample 1.	

## 2.4 Connection Diagram of Test System

### <WLAN Tx Mode>

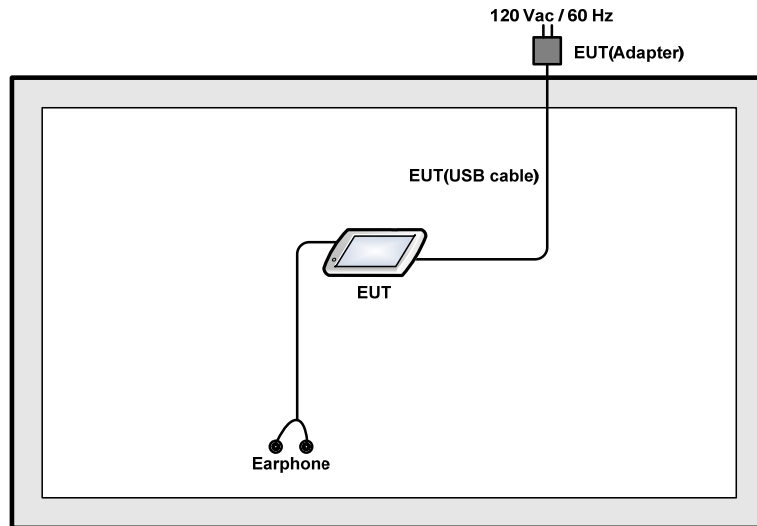

### <AC Conducted Emission Mode>

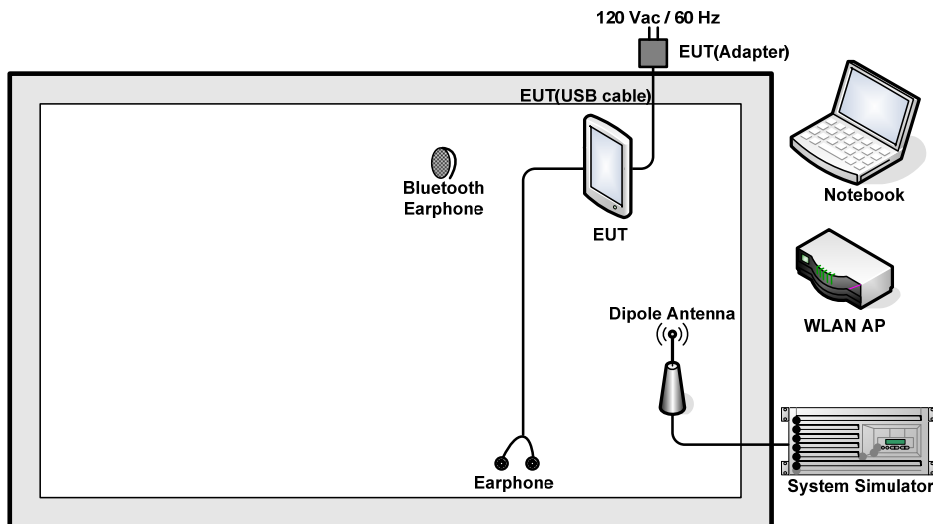

## 2.5 Support Unit used in test configuration and system

Item	Equipment	Trade Name	Model Name	FCC ID	Data Cable	Power Cord
1.	System Simulator	R&S	CMU 200	N/A	N/A	Unshielded, 1.8m
2.	WLAN AP	LINKSYS	WRT600N	Q87-WRT600NV11	N/A	Unshielded, 1.8 m
3.	Notebook	Lenovo	G480	FCC DoC	N/A	AC I/P: Unshielded, 1.2 m DC O/P: Shielded, 1.8 m
4.	Bluetooth Earphone	Lenovo	LBH505	N/A	N/A	N/A
5.	Bluetooth Earphone	Lenovo	BH-102	N/A	N/A	N/A
6.	Earphone	Lenovo	LH102	N/A	Unshielded, 1.2 m	N/A

## 2.6 EUT Operation Test Setup

For WLAN RF test items, an engineering test program was provided and enabled to make EUT continuous transmit/receive.

For AC power line conducted emissions, the EUT was set to connect with the WLAN AP under large package sizes transmission.

## 2.7 Measurement Results Explanation Example

**For all conducted test items:**

The offset level is set in the spectrum analyzer to compensate the RF cable loss and attenuator factor between EUT conducted output port and spectrum analyzer. With the offset compensation, the spectrum analyzer reading level is exactly the EUT RF output level.

Example:

The spectrum analyzer offset is derived from RF cable loss and attenuator factor.

*Offset = RF cable loss + attenuator factor.*

Following shows an offset computation example with cable loss 5 dB and 10dB attenuator.

$$\begin{aligned} \text{Offset(dB)} &= \text{RF cable loss(dB)} + \text{attenuator factor(dB)}. \\ &= 5 + 10 = 15 \text{ (dB)} \end{aligned}$$

### 3. Test Result

#### 3.1 6dB Bandwidth Measurement

##### 3.1.1 Limit of 6dB Bandwidth

The minimum 6 dB bandwidth shall be at least 500 kHz.

##### 3.1.2 Measuring Instruments

The measuring equipment is listed in the section 4 of this test report.

##### 3.1.3 Test Procedures

1. The testing follows FCC KDB Publication No. 558074 DTS D01 Meas. Guidance v03r03.
2. The RF output of EUT was connected to the spectrum analyzer by RF cable and attenuator. The path loss was compensated to the results for each measurement.
3. Set to the maximum power setting and enable the EUT transmit continuously.
4. Make the measurement with the spectrum analyzer's resolution bandwidth (RBW) = 100 kHz. Set the Video bandwidth (VBW) = 300 kHz. In order to make an accurate measurement. The 6 dB bandwidth must be greater than 500 kHz.
5. Measure and record the results in the test report.

##### 3.1.4 Test Setup

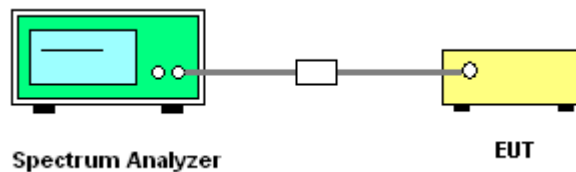



### 3.1.5 Test Result of 6dB Bandwidth

Please refer to Appendix A of this test report.

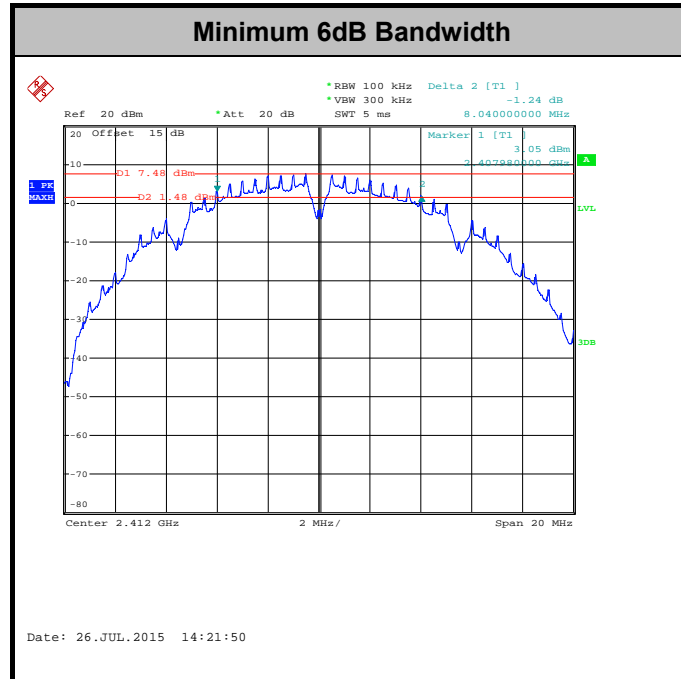

## 3.2 Output Power Measurement

### 3.2.1 Limit of Output Power

For systems using digital modulation in the 2400-2483.5MHz, the limit for peak output power is 30dBm. If transmitting Antenna of directional gain greater than 6dBi are used the peak output power from the intentional radiator shall be reduced below the above stated value by the amount in dB that the directional gain of the Antenna exceeds 6 dBi. In case of point-to-point operation, the limit has to be reduced by 1dB for every 3dB that the directional gain of the Antenna exceeds 6dBi.

### 3.2.2 Measuring Instruments

The measuring equipment is listed in the section 4 of this test report.

### 3.2.3 Test Procedures

1. The testing follows the Measurement Procedure of FCC KDB No. 558074 DTS D01 Meas. Guidance v03r03 section 9.1.2 PKPM1 Peak power meter method.
2. The RF output of EUT was connected to the power meter by RF cable and attenuator. The path loss was compensated to the results for each measurement.
3. Set to the maximum power setting and enable the EUT transmit continuously.
4. Measure the conducted output power and record the results in the test report.

### 3.2.4 Test Setup

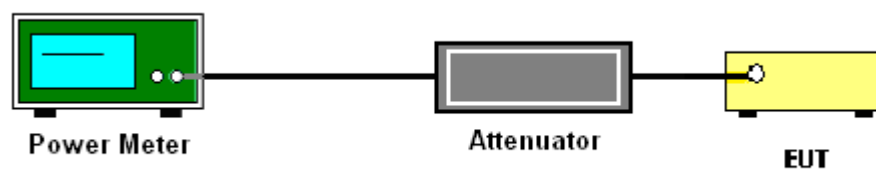

### 3.2.5 Test Result of Peak Output Power

Please refer to Appendix A of this test report.

### 3.2.6 Test Result of Average output Power (Reporting Only)

Please refer to Appendix A of this test report.

### 3.3 Power Spectral Density Measurement

#### 3.3.1 Limit of Power Spectral Density

The peak power spectral density shall not be greater than 8dBm in any 3kHz band at any time interval of continuous transmission.

#### 3.3.2 Measuring Instruments

The measuring equipment is listed in the section 4 of this test report.

#### 3.3.3 Test Procedures

1. The testing follows Measurement Procedure 10.2 Method PKPSD of FCC KDB Publication No. 558074 D01 DTS Meas. Guidance v03r03
2. The RF output of EUT was connected to the spectrum analyzer by RF cable and attenuator. The path loss was compensated to the results for each measurement.
3. Set to the maximum power setting and enable the EUT transmit continuously.
4. Make the measurement with the spectrum analyzer's resolution bandwidth (RBW) = 3 kHz. Video bandwidth VBW = 10 kHz In order to make an accurate measurement, set the span to 1.5 times DTS Channel Bandwidth. (6dB BW)
5. Detector = peak, Sweep time = auto couple, Trace mode = max hold, Allow trace to fully stabilize. Use the peak marker function to determine the maximum power level.
6. Measure and record the results in the test report.

#### 3.3.4 Test Setup

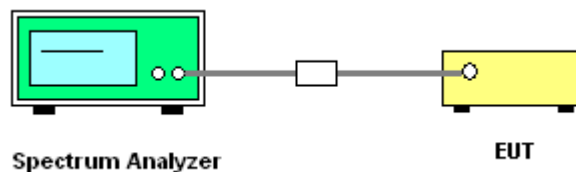





### 3.3.5 Test Result of Power Spectral Density

Please refer to Appendix A of this test report.

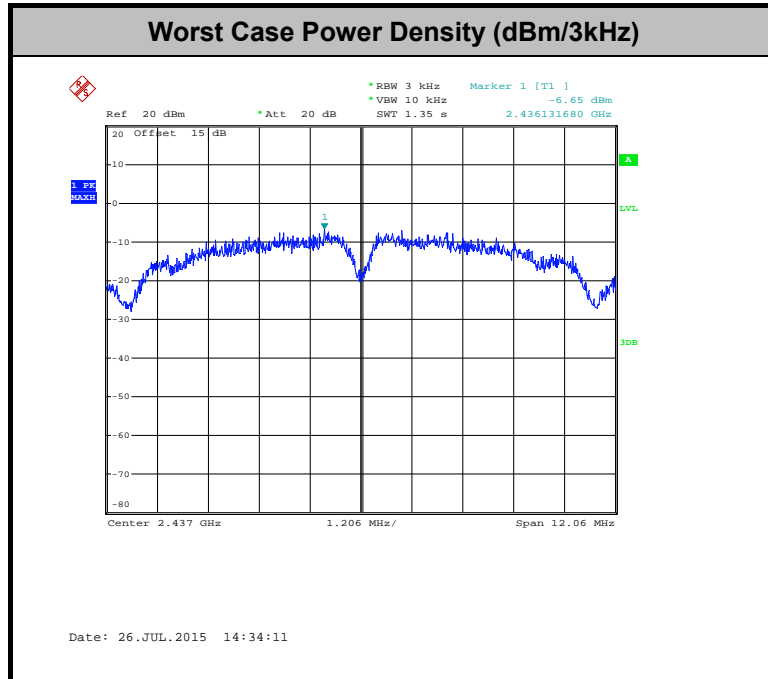

## 3.4 Conducted Band Edges and Spurious Emission Measurement

### 3.4.1 Limit of Conducted Band Edges and Spurious Emission Measurement

In any 100 kHz bandwidth outside of the authorized frequency band, the emissions which fall in the non-restricted bands shall be attenuated at least 20 dB / 30dB relative to the maximum PSD level in 100 kHz by RF conducted measurement and radiated emissions which fall in the restricted bands, as defined in Section 15.205(a), must also comply with the radiated emission limits specified in Section 15.209(a).

### 3.4.2 Measuring Instruments

The measuring equipment is listed in the section 4 of this test report.

### 3.4.3 Test Procedures

1. The testing follows FCC KDB Publication No. 558074 D01 DTS Meas. Guidance v03r03.
2. The RF output of EUT was connected to the spectrum analyzer by RF cable and attenuator. The path loss was compensated to the results for each measurement.
3. Set to the maximum power setting and enable the EUT transmit continuously.
4. Set RBW = 100 kHz, VBW=300 kHz, Peak Detector. Unwanted Emissions measured in any 100 kHz bandwidth outside of the authorized frequency band shall be attenuated by at least 20 dB relative to the maximum in-band peak PSD level in 100 kHz when maximum peak conducted output power procedure is used. If the transmitter complies with the conducted power limits based on the use of RMS averaging over a time interval, the attenuation required under this paragraph shall be 30 dB instead of 20 dB per 15.247(d).
5. Measure and record the results in the test report.
6. The RF fundamental frequency should be excluded against the limit line in the operating frequency band.

### 3.4.4 Test Setup

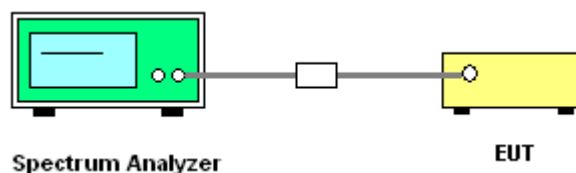



### 3.4.5 Test Result of Conducted Band Edges and Spurious Emission

Test Mode :	802.11b	Temperature :	24~26°C
Test Band :	2.4GHz Low	Relative Humidity :	50~53%
Test Channel :	01	Test Engineer :	Mygai Mo

#### WLAN 802.11b Channel 01

<b>100kHz PSD reference Level</b>	<b>Low Channel Plot</b>
-----------------------------------	-------------------------

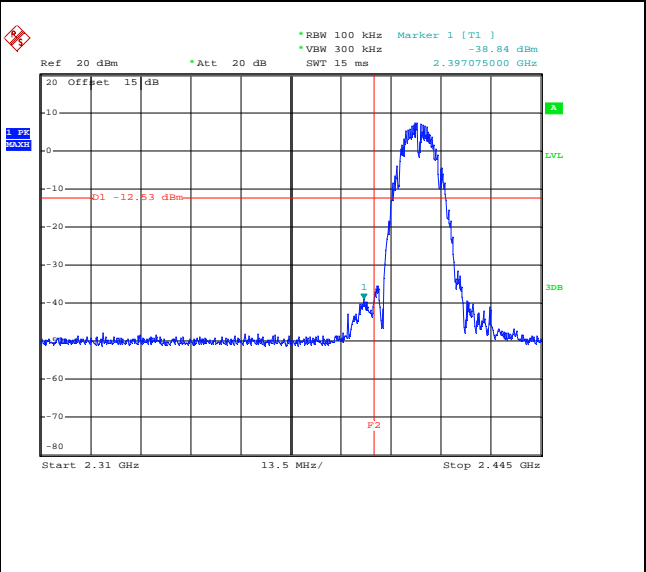
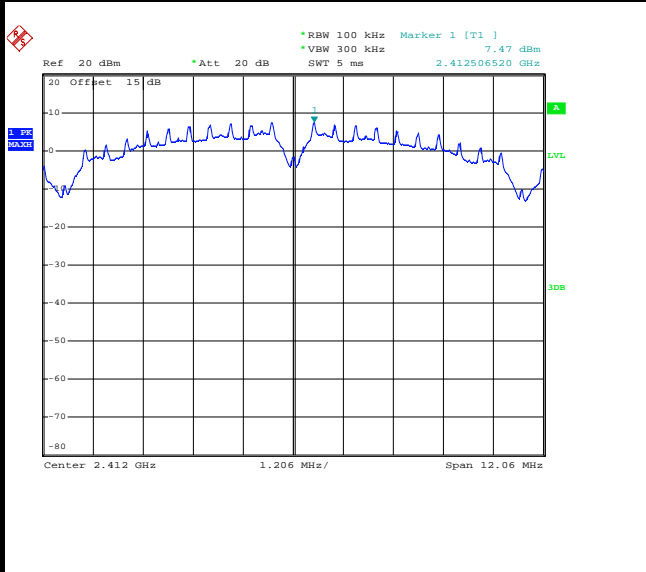

Date: 26.JUL.2015 14:22:42

Date: 26.JUL.2015 14:30:35

#### Spurious Emission 30MHz~3GHz

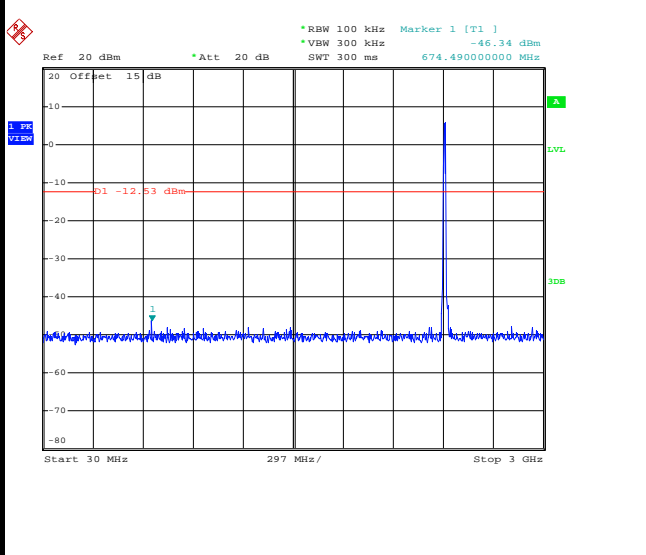

Date: 26.JUL.2015 14:31:52

#### Spurious Emission 2GHz~25GHz

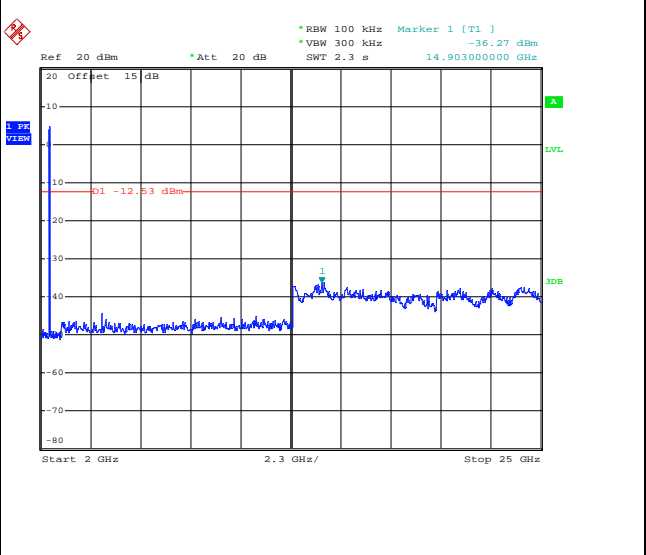

Date: 26.JUL.2015 14:31:17



Test Mode :	802.11b	Temperature :	24~26°C
Test Band :	2.4GHz Mid	Relative Humidity :	50~53%
Test Channel :	06	Test Engineer :	Mygai Mo

WLAN 802.11b Channel 06

100kHz PSD reference Level

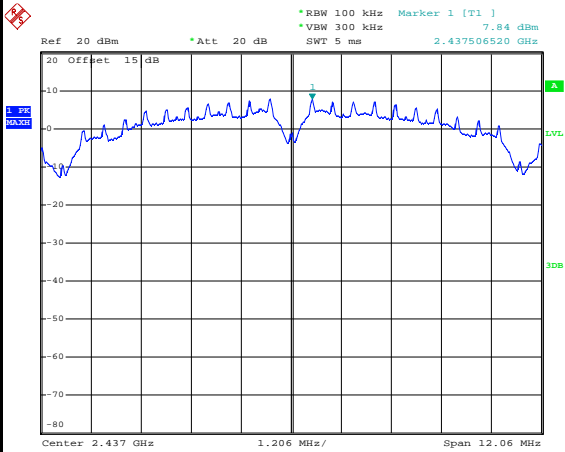

Date: 26.JUL.2015 14:35:19

Spurious Emission 30MHz~3GHz

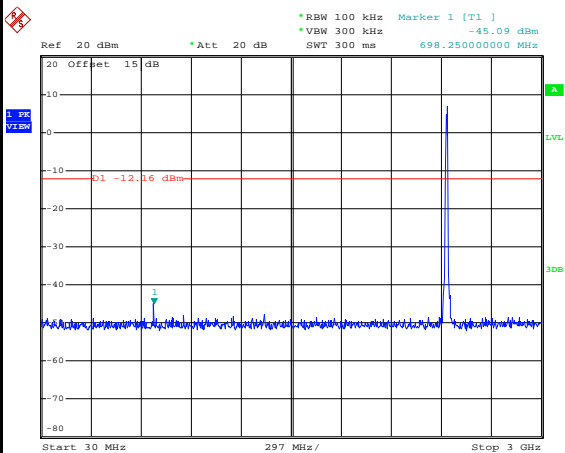

Date: 26.JUL.2015 14:36:31

Spurious Emission 2GHz~25GHz

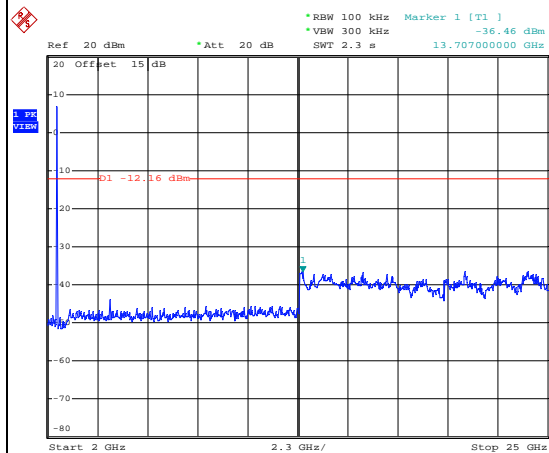

Date: 26.JUL.2015 14:36:49



Test Mode :	802.11b	Temperature :	24~26°C
Test Band :	2.4GHz High	Relative Humidity :	50~53%
Test Channel :	11	Test Engineer :	Mygai Mo

WLAN 802.11b Channel 11

100kHz PSD reference Level

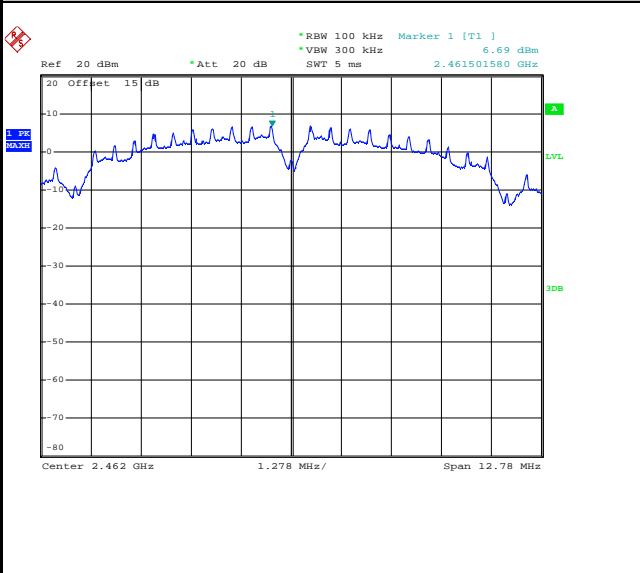

High Channel Plot

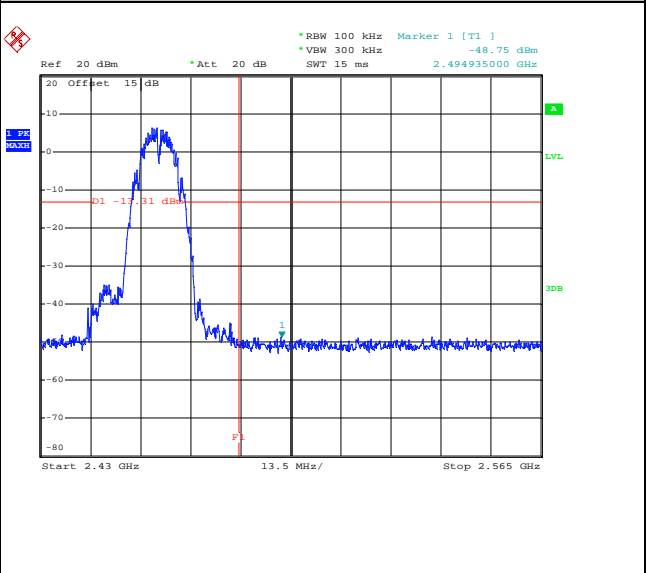

Spurious Emission 30MHz~3GHz

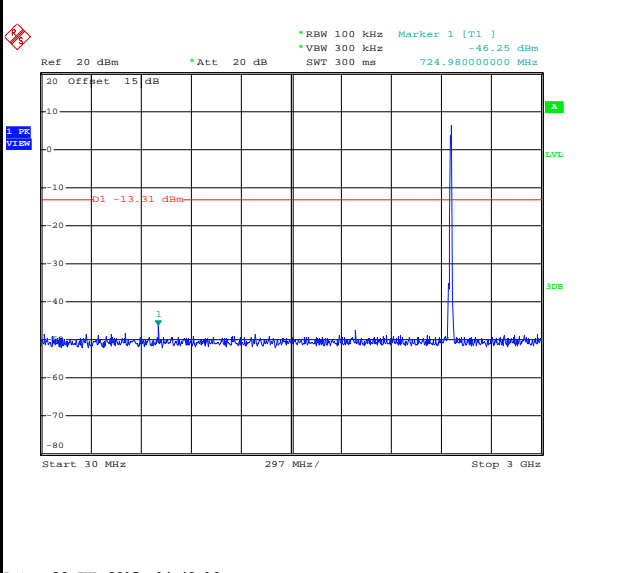

Spurious Emission 2GHz~25GHz

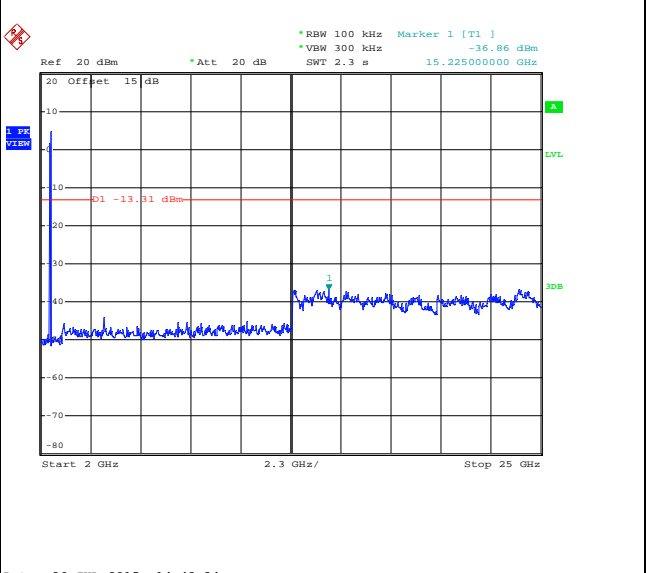



Test Mode :	802.11g	Temperature :	24~26°C
Test Band :	2.4GHz Low	Relative Humidity :	50~53%
Test Channel :	01	Test Engineer :	Mygai Mo

WLAN 802.11g Channel 01

100kHz PSD reference Level

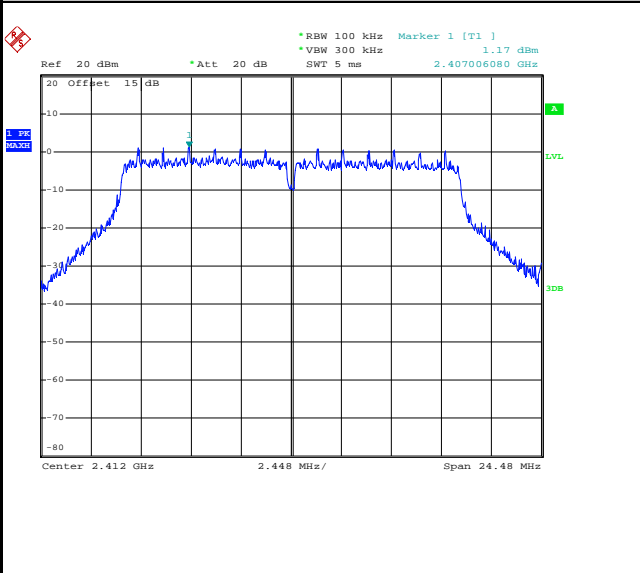

Low Channel Plot

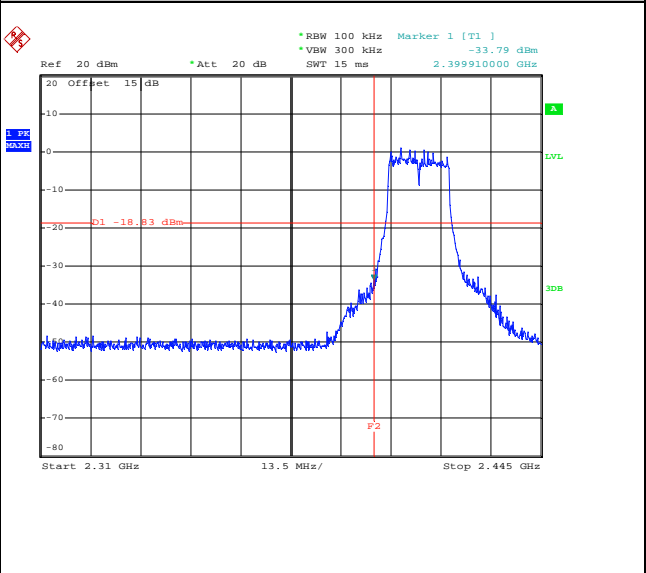

Spurious Emission 30MHz~3GHz

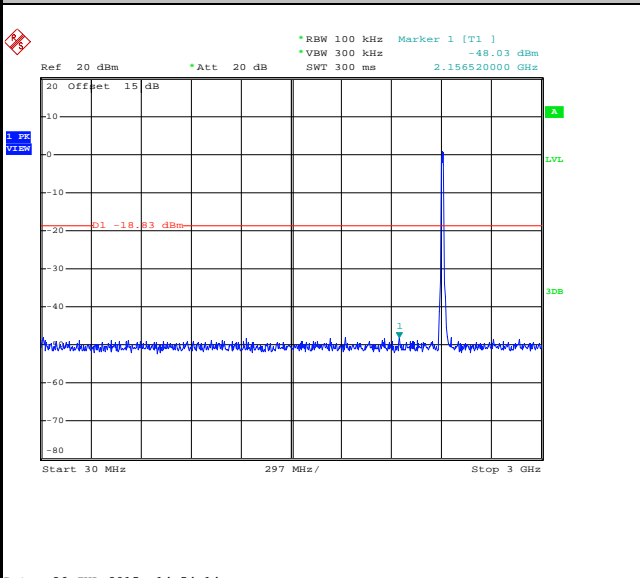

Spurious Emission 2GHz~25GHz

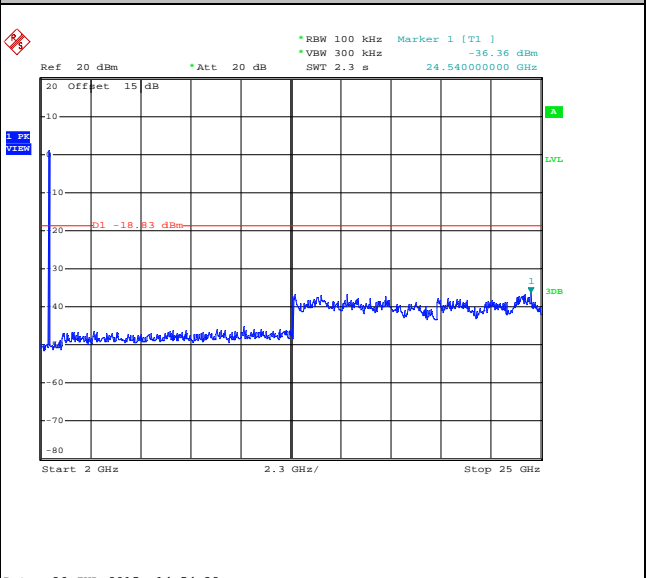



Test Mode :	802.11g	Temperature :	24~26°C
Test Band :	2.4GHz Mid	Relative Humidity :	50~53%
Test Channel :	06	Test Engineer :	Mygai Mo

WLAN 802.11g Channel 06

100kHz PSD reference Level

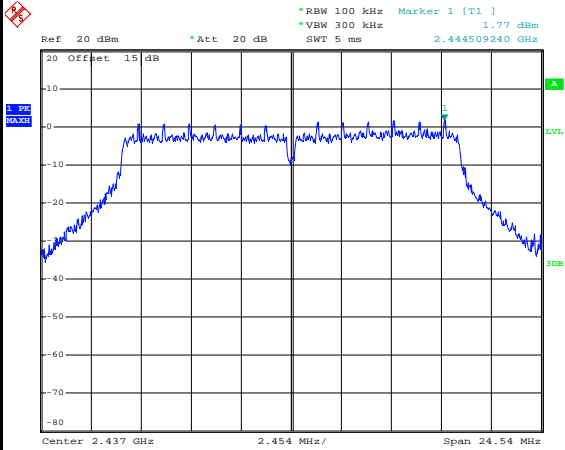

Date: 26.JUL.2015 14:57:49

Spurious Emission 30MHz~3GHz

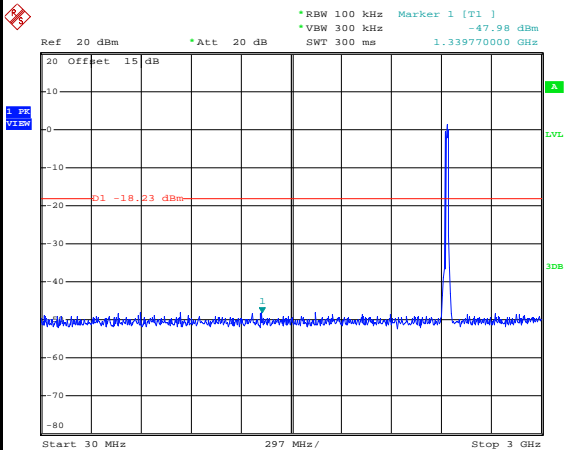

Date: 26.JUL.2015 14:59:03

Spurious Emission 2GHz~25GHz

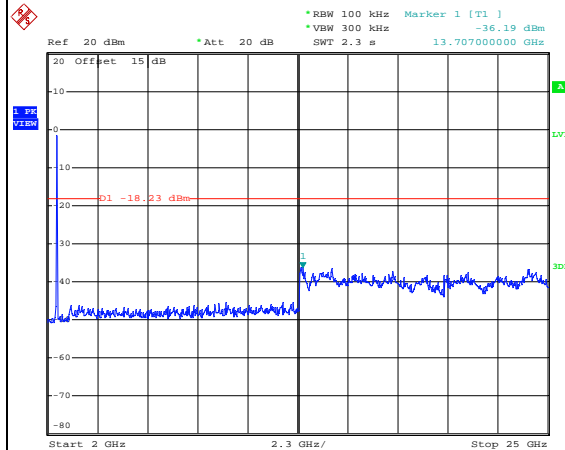

Date: 26.JUL.2015 14:59:20



Test Mode :	802.11g	Temperature :	24~26°C
Test Band :	2.4GHz High	Relative Humidity :	50~53%
Test Channel :	11	Test Engineer :	Mygai Mo

WLAN 802.11g Channel 11

100kHz PSD reference Level

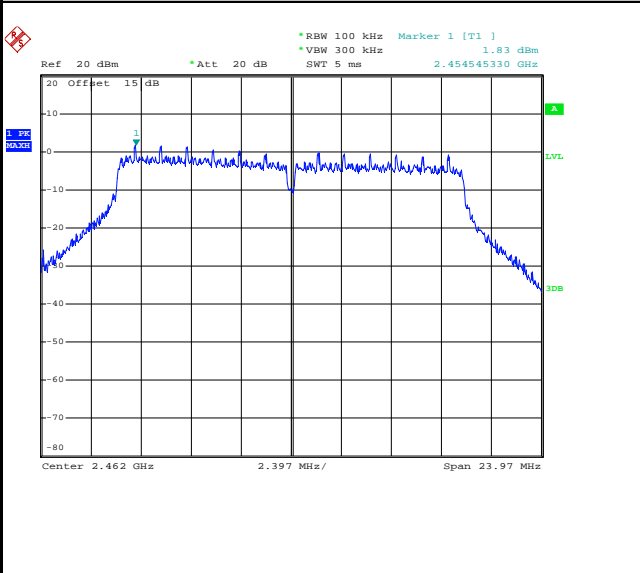

High Channel Plot

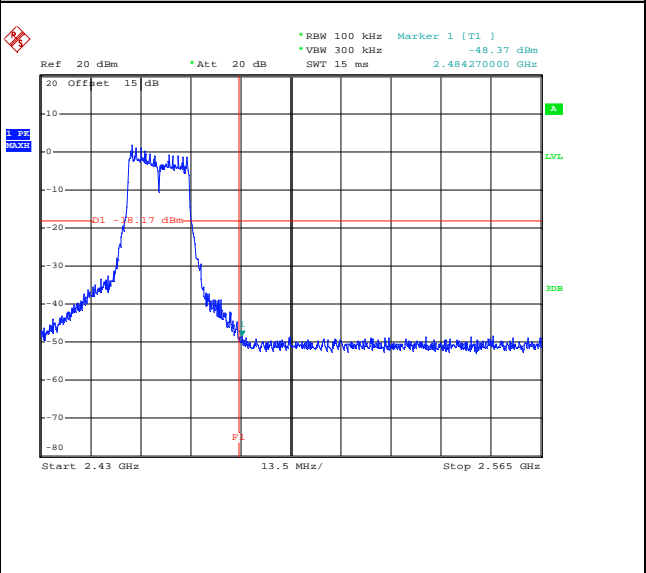

Spurious Emission 30MHz~3GHz

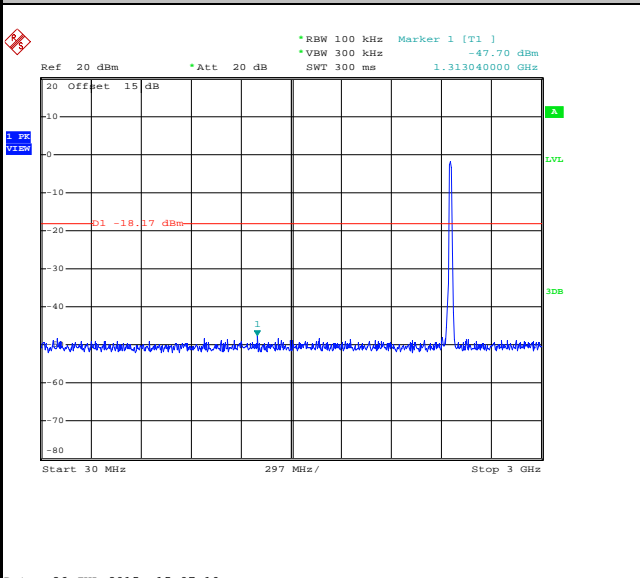

Spurious Emission 2GHz~25GHz

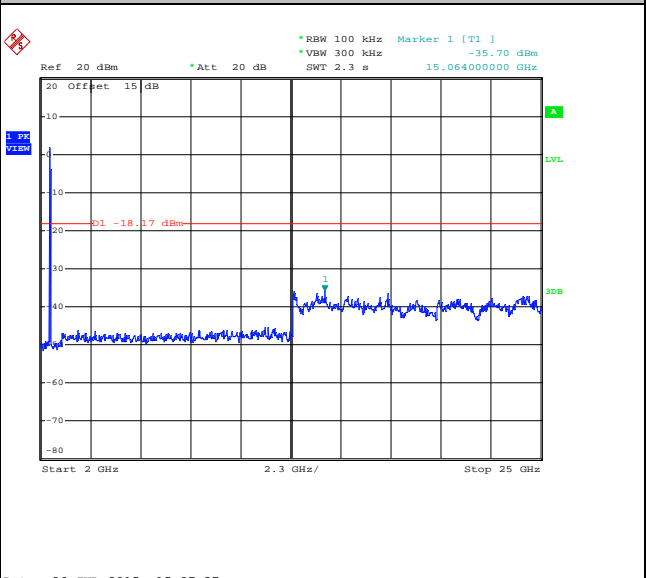





Test Mode :	802.11n HT20	Temperature :	24~26°C
Test Band :	2.4GHz Low	Relative Humidity :	50~53%
Test Channel :	01	Test Engineer :	Mygai Mo

WLAN 802.11n HT20 Channel 01

100kHz PSD reference Level

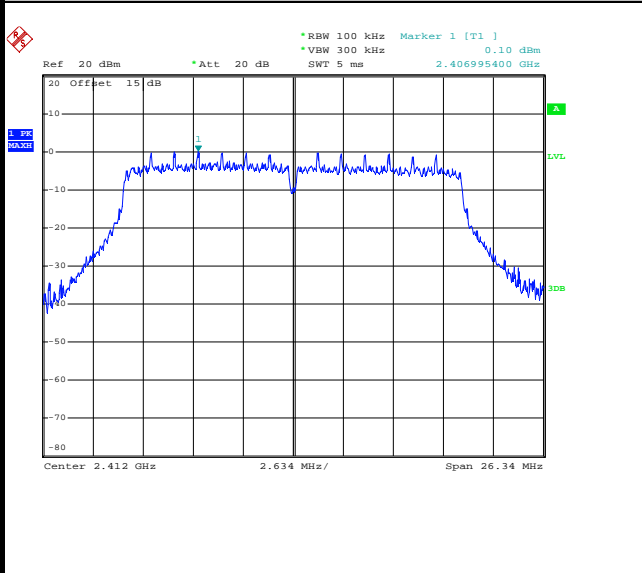

Low Channel Plot

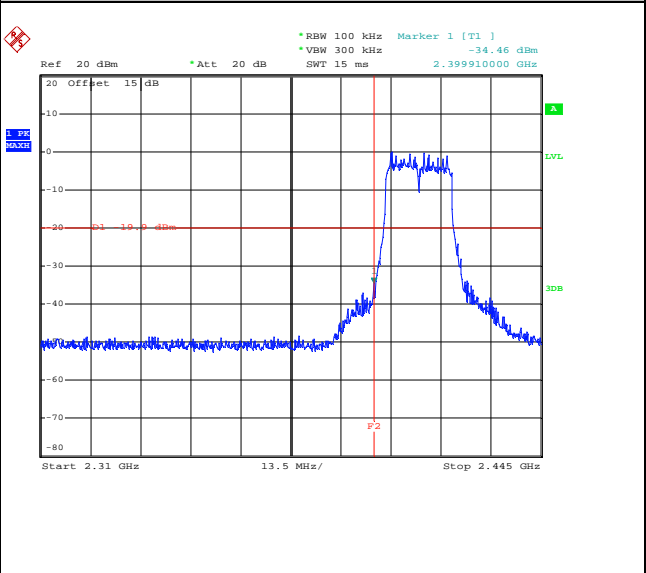

Spurious Emission 30MHz~3GHz

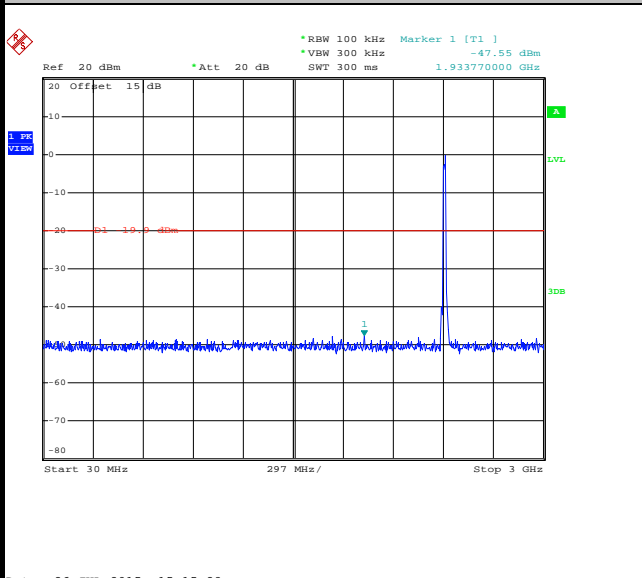

Spurious Emission 2GHz~25GHz

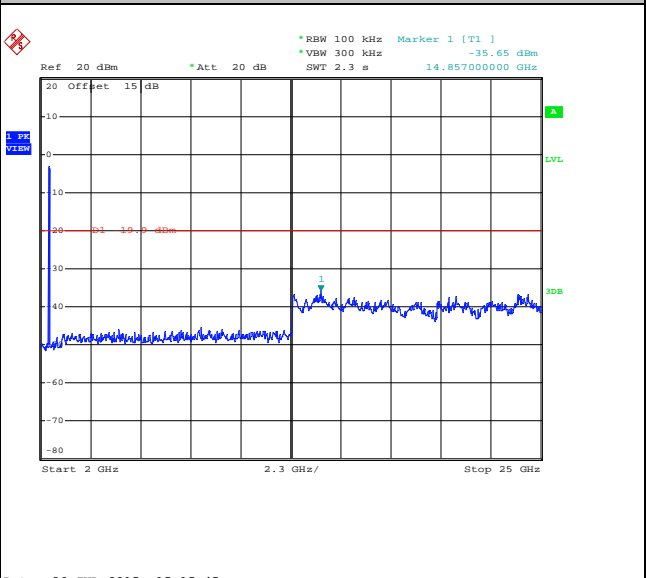



Test Mode :	802.11n HT20	Temperature :	24~26°C
Test Band :	2.4GHz Mid	Relative Humidity :	50~53%
Test Channel :	06	Test Engineer :	Mygai Mo

WLAN 802.11n HT20 Channel 06

100kHz PSD reference Level

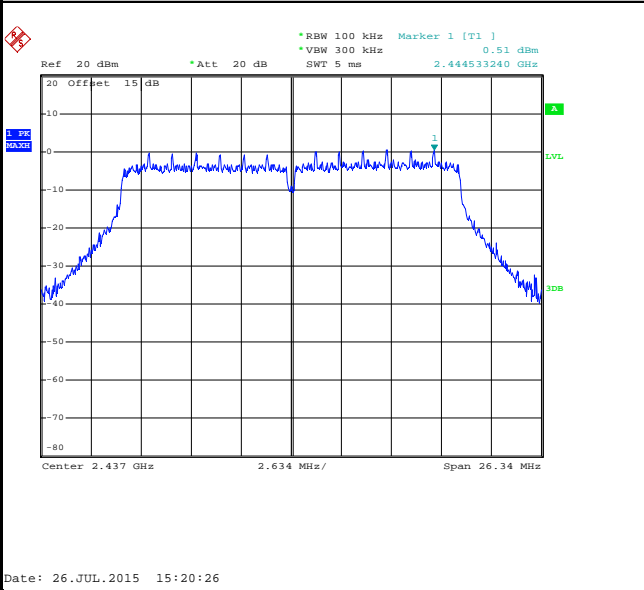

Spurious Emission 30MHz~3GHz

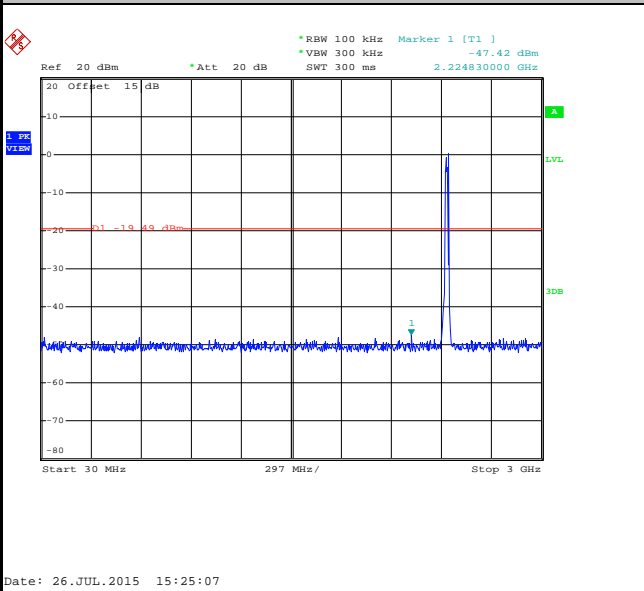

Spurious Emission 2GHz~25GHz

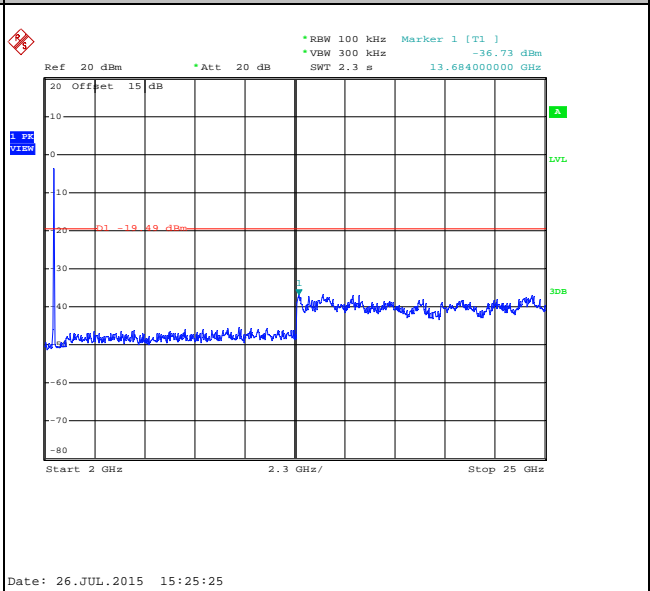



Test Mode :	802.11n HT20	Temperature :	24~26°C
Test Band :	2.4GHz High	Relative Humidity :	50~53%
Test Channel :	11	Test Engineer :	Mygai Mo

WLAN 802.11n HT20 Channel 11

100kHz PSD reference Level

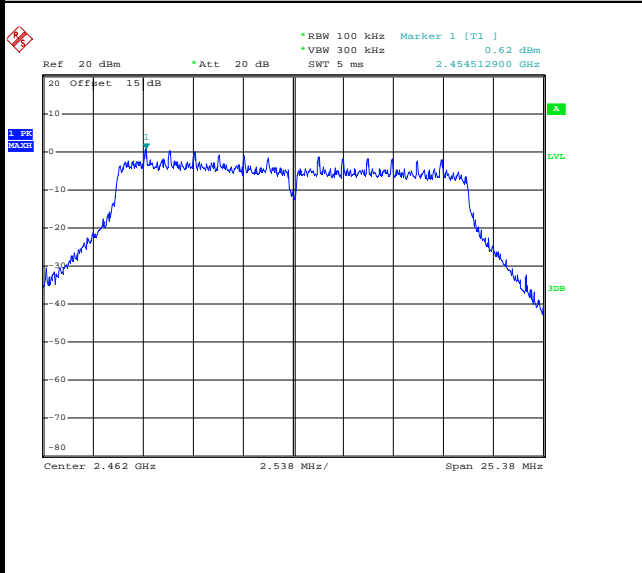

High Channel Plot

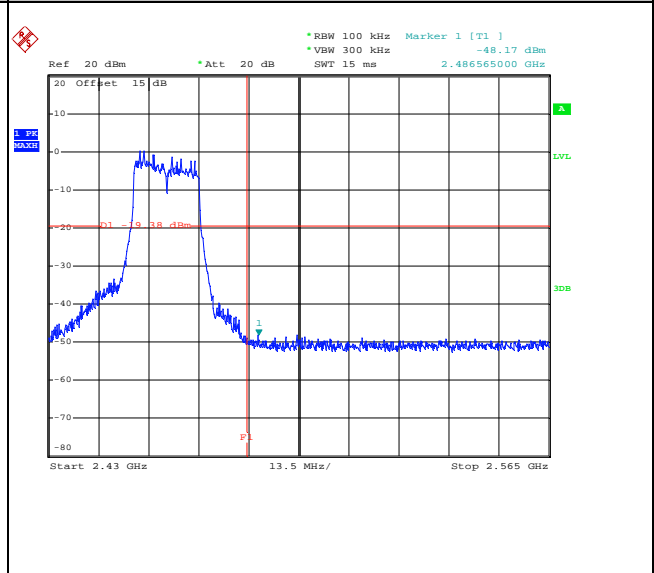

Spurious Emission 30MHz~3GHz

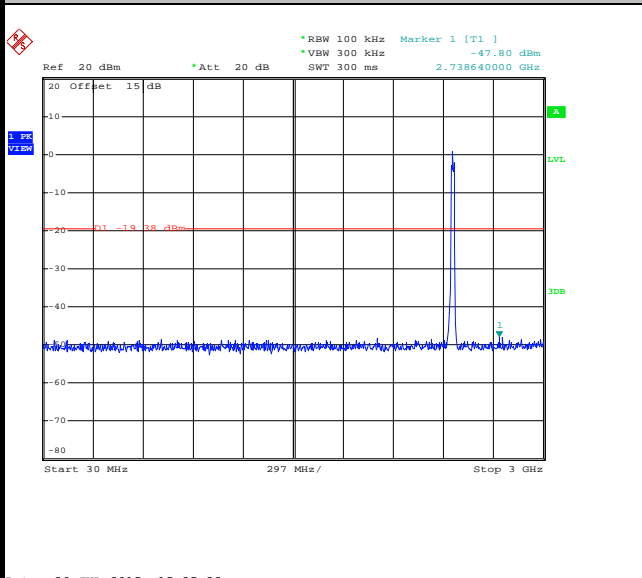

Spurious Emission 2GHz~25GHz

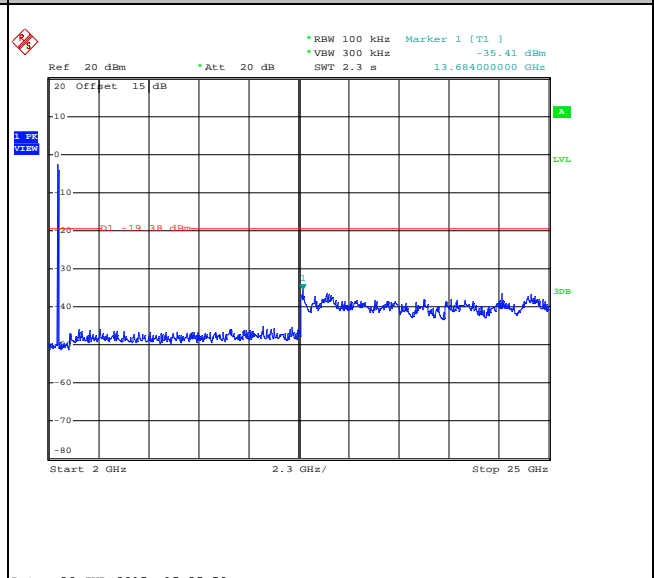



### 3.5 Radiated Band Edges and Spurious Emission Measurement

#### 3.5.1 Limit of Radiated band edge and Spurious Emission Measurement

In any 100 kHz bandwidth outside the intentional radiator frequency band, all harmonics/spurious must be at least 20 dB below the highest emission level within the authorized band. If the output power of this device was measured by spectrum analyzer, the attenuation under this paragraph shall be 30 dB instead of 20 dB. In addition, radiated emissions which fall in the restricted bands must also comply with the FCC section 15.209 limits as below.

Frequency (MHz)	Field Strength (microvolts/meter)	Measurement Distance (meters)
0.009 – 0.490	2400/F(kHz)	300
0.490 – 1.705	24000/F(kHz)	30
1.705 – 30.0	30	30
30 – 88	100	3
88 – 216	150	3
216 - 960	200	3
Above 960	500	3

#### 3.5.2 Measuring Instruments

The measuring equipment is listed in the section 4 of this test report.



3.5.3 Test Procedures

1. The testing follows FCC KDB Publication No. 558074 D01 DTS Meas. Guidance v03r03.
2. The EUT was arranged to its worst case and then tune the antenna tower (from 1 m to 4 m) and turntable (from 0 degree to 360 degrees) to find the maximum reading. A pre-amp and a high pass filter are used for the test in order to get better signal level.
3. The EUT was placed on a turntable with 0.8 meter for frequency below 1GHz and 1.5 meter for frequency above 1GHz respectively above ground.
4. The EUT was set 3 meters from the interference receiving antenna, which was mounted on the top of a variable height antenna tower.
5. Corrected Reading: Antenna Factor + Cable Loss + Read Level - Preamp Factor = Level
6. For measurement below 1GHz, If the emission level of the EUT measured by the peak detector is 3 dB lower than the applicable limit, the peak emission level will be reported. Otherwise, the emission measurement will be repeated using the quasi-peak detector and reported.
7. Use the following spectrum analyzer settings:
  - (1) Span shall wide enough to fully capture the emission being measured;
  - (2) Set RBW=100 kHz for  $f < 1 \text{ GHz}$ ;  $\text{VBW} \geq \text{RBW}$ ; Sweep = auto; Detector function = peak; Trace = max hold;
  - (3) Set RBW = 1 MHz, VBW= 3MHz for  $f \geq 1 \text{ GHz}$  for peak measurement.
 

For average measurement:

    - $\text{VBW} = 10 \text{ Hz}$ , when duty cycle is no less than 98 percent.
    - $\text{VBW} \geq 1/T$ , when duty cycle is less than 98 percent where T is the minimum transmission duration over which the transmitter is on and is transmitting at its maximum power control level for the tested mode of operation.

Band	Duty Cycle(%)	T(ms)	1/T(kHz)	VBW Setting
802.11b	97.41	8.19	0.12	300Hz
802.11g	87.63	1.37	0.73	1kHz
2.4GHz 802.11n HT20	85.98	1.27	0.79	1kHz

### 3.5.4 Test Setup

For radiated emissions below 30MHz

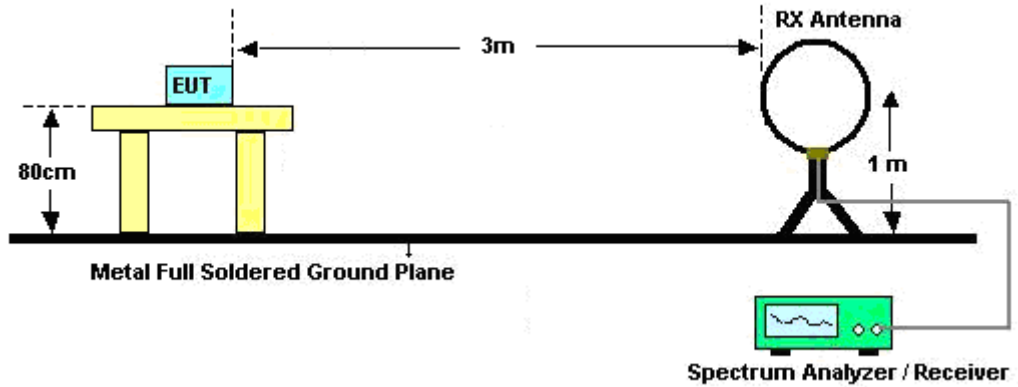

For radiated emissions from 30MHz to 1GHz

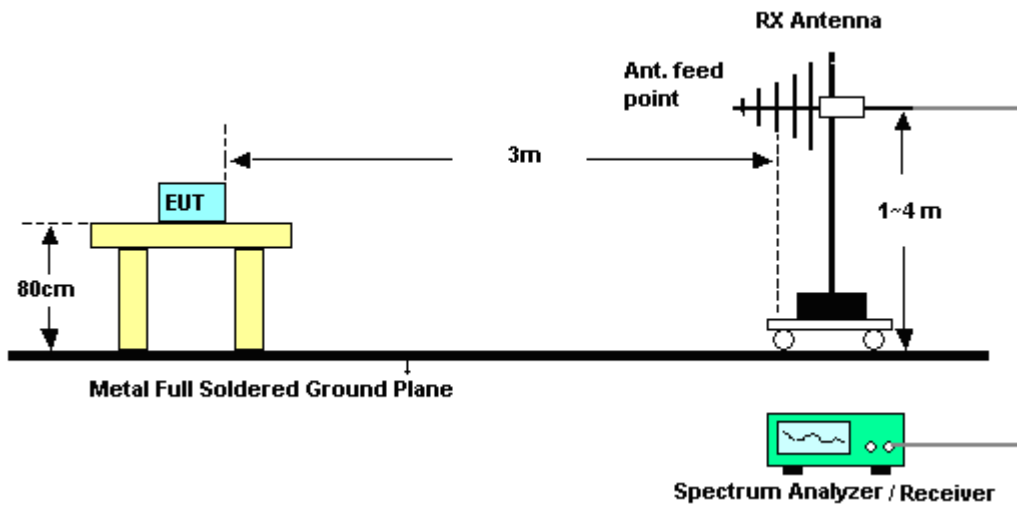

For radiated emissions above 1GHz

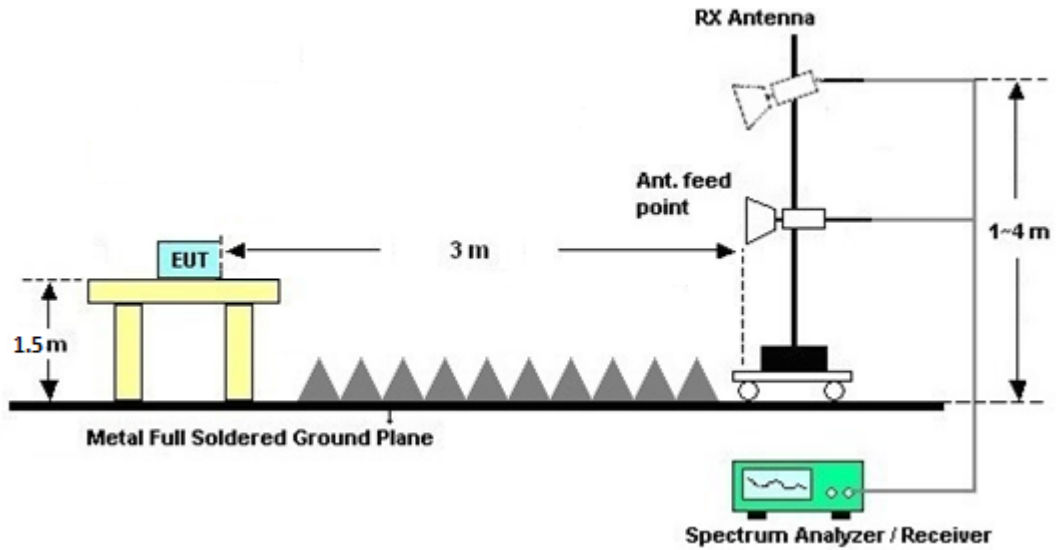

### 3.5.5 Test Results of Radiated Spurious Emissions (9kHz ~ 30MHz)

The low frequency, which started from 9 kHz to 30MHz, was pre-scanned and the result which was 20dB lower than the limit line per 15.31(o) was not reported.

### 3.5.6 Test Result of Radiated Spurious at Band Edges

Please refer to Appendix B.

### 3.5.7 Test Result of Radiated Spurious Emission (30MHz ~ 10<sup>th</sup> Harmonic)

Please refer to Appendix B.

## 3.6 AC Conducted Emission Measurement

### 3.6.1 Limit of AC Conducted Emission

For equipment that is designed to be connected to the public utility (AC) power line, the radio frequency voltage that is conducted back onto the AC power line on any frequency or frequencies within the band 150 kHz to 30 MHz shall not exceed the limits in the following table.

Frequency of Emission (MHz)	Conducted Limit (dB $\mu$ V)	
	Quasi-Peak	Average
0.15-0.5	66 to 56*	56 to 46*
0.5-5	56	46
5-30	60	50

\*Decreases with the logarithm of the frequency.

### 3.6.2 Measuring Instruments

The measuring equipment is listed in the section 4 of this test report.

### 3.6.3 Test Procedures

1. The EUT was placed 0.4 meter from the conducting wall of the shielding room, and it was kept at least 80 centimeters from any other grounded conducting surface.
2. Connect EUT to the power mains through a line impedance stabilization network (LISN).
3. All the support units are connecting to the other LISN.
4. The LISN provides 50 ohm coupling impedance for the measuring instrument.
5. The FCC states that a 50 ohm, 50 microhenry LISN should be used.
6. Both sides of AC line were checked for maximum conducted interference.
7. The frequency range from 150 kHz to 30 MHz was searched.
8. Set the test-receiver system to Peak Detect Function and specified bandwidth (IF bandwidth = 9kHz) with Maximum Hold Mode.



### 3.6.4 Test Setup

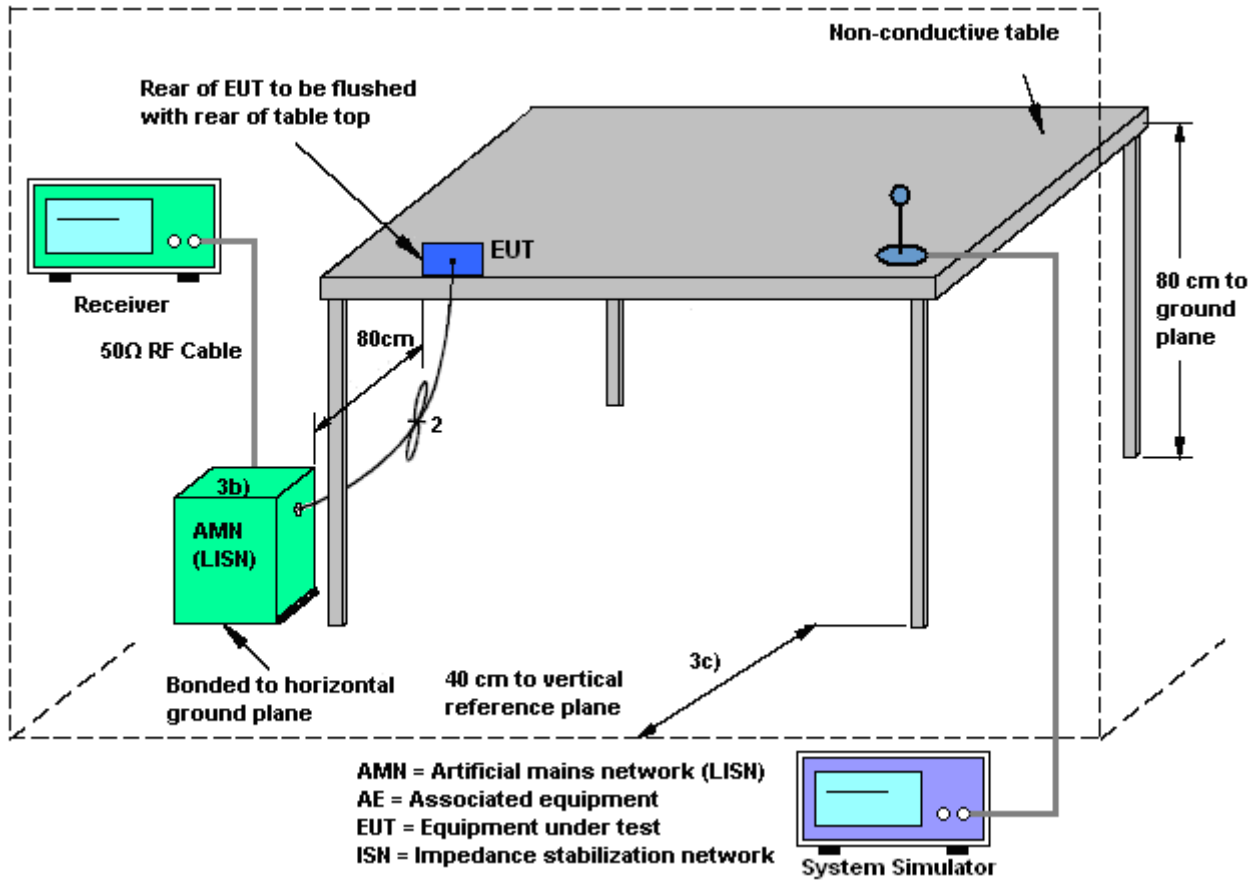



3.6.5 Test Result of AC Conducted Emission

Test Mode :	Mode 1	Temperature :	22~24°C
Test Engineer :	Amos Zhang	Relative Humidity :	43~45%
Test Voltage :	120Vac / 60Hz	Phase :	Line
Function Type :	GSM850 Idle + Bluetooth Link + WLAN Link + Earphone + Battery 1 + USB Cable (Charging from Adapter) for Sample 1		

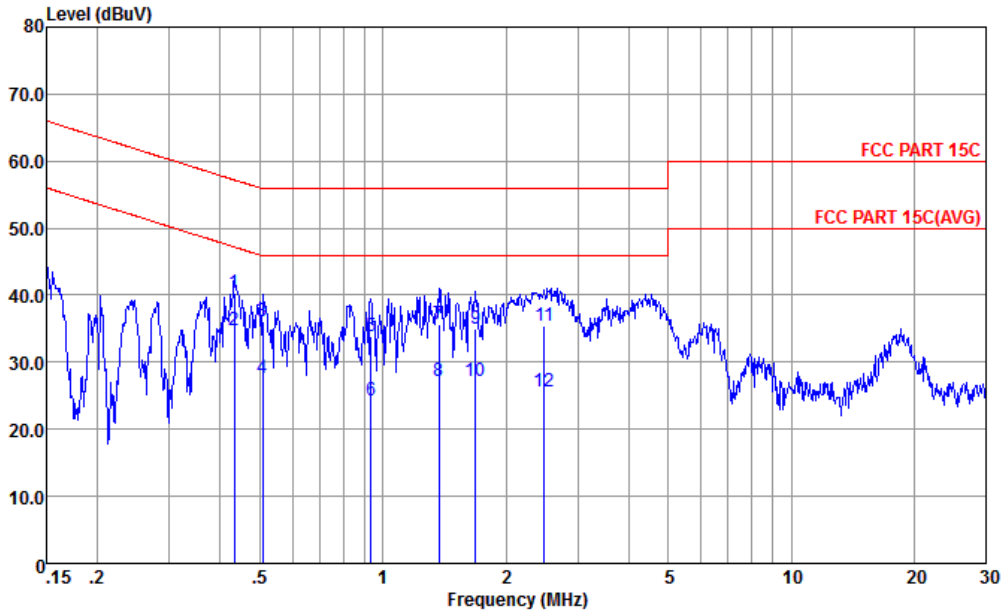

Site : CO01-KS  
 Condition : FCC PART 15C LISN-L20140306 LINE

mode : Mode 1

	Freq	Level	Over Limit	Limit Line	Read Level	LISN Factor	Cable Loss	Remark
	MHz	dBuV	dB	dBuV	dBuV	dB	dB	
1	0.43	40.39	-16.81	57.20	29.50	0.27	10.62	QP
2 *	0.43	34.69	-12.51	47.20	23.80	0.27	10.62	Average
3	0.51	36.12	-19.88	56.00	25.30	0.20	10.62	QP
4	0.51	27.62	-18.38	46.00	16.80	0.20	10.62	Average
5	0.93	33.96	-22.04	56.00	23.20	0.11	10.65	QP
6	0.93	24.26	-21.74	46.00	13.50	0.11	10.65	Average
7	1.37	35.57	-20.43	56.00	24.80	0.10	10.67	QP
8	1.37	27.27	-18.73	46.00	16.50	0.10	10.67	Average
9	1.69	34.99	-21.01	56.00	24.20	0.10	10.69	QP
10	1.69	27.29	-18.71	46.00	16.50	0.10	10.69	Average
11	2.49	35.34	-20.66	56.00	24.50	0.11	10.73	QP
12	2.49	25.64	-20.36	46.00	14.80	0.11	10.73	Average



Test Mode :	Mode 1	Temperature :	22~24°C
Test Engineer :	Amos Zhang	Relative Humidity :	43~45%
Test Voltage :	120Vac / 60Hz	Phase :	Neutral
Function Type :	GSM850 Idle + Bluetooth Link + WLAN Link + Earphone + Battery 1 + USB Cable (Charging from Adapter) for Sample 1		

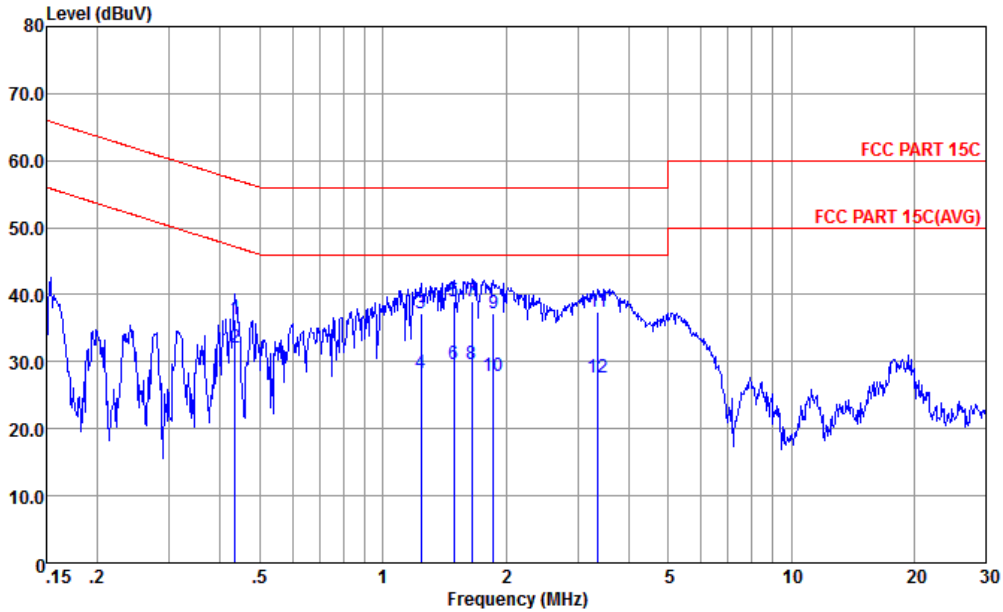

Site : CO01-KS  
 Condition : FCC PART 15C LISN-N20140306 NEUTRAL

mode : Mode 1

	Freq	Level	Over	Limit	Read	LISN	Cable	Remark
	MHz	dBuV	Limit	Line	Level	Factor	Loss	
			dB	dBuV	dBuV	dB	dB	
1	0.44	36.28	-20.87	57.15	25.30	0.36	10.62	QP
2 *	0.44	32.18	-14.97	47.15	21.20	0.36	10.62	Average
3	1.24	37.26	-18.74	56.00	26.50	0.10	10.66	QP
4	1.24	28.26	-17.74	46.00	17.50	0.10	10.66	Average
5	1.50	38.98	-17.02	56.00	28.20	0.10	10.68	QP
6	1.50	29.58	-16.42	46.00	18.80	0.10	10.68	Average
7	1.65	38.89	-17.11	56.00	28.10	0.10	10.69	QP
8	1.65	29.59	-16.41	46.00	18.80	0.10	10.69	Average
9	1.87	37.30	-18.70	56.00	26.50	0.10	10.70	QP
10	1.87	27.90	-18.10	46.00	17.10	0.10	10.70	Average
11	3.36	37.47	-18.53	56.00	26.50	0.16	10.81	QP
12	3.36	27.57	-18.43	46.00	16.60	0.16	10.81	Average



## **3.7 Antenna Requirements**

### **3.7.1 Standard Applicable**

If directional gain of transmitting antennas is greater than 6dBi, the power shall be reduced by the same level in dB comparing to gain minus 6dBi. For the fixed point-to-point operation, the power shall be reduced by one dB for every 3 dB that the directional gain of the antenna exceeds 6 dBi. The use of a permanently attached antenna or of an antenna that uses a unique coupling to the intentional radiator shall be considered sufficient to comply with the FCC rule.

### **3.7.2 Antenna Anti-Replacement Construction**

An embedded-in antenna design is used.

### **3.7.3 Antenna Gain**

The antenna peak gain of EUT is less than 6 dBi. Therefore, it is not necessary to reduce maximum peak output power limit.



### 4. List of Measuring Equipment

Instrument	Manufacturer	Model No.	Serial No.	Characteristics	Calibration Date	Test Date	Due Date	Remark
Spectrum Analyzer	R&S	FSP30	101400	9kHz~30GHz	Jan. 28, 2015	Jul. 26, 2015	Jan. 27, 2016	Conducted (TH01-SZ)
Pulse Power Sensor	Anritsu	MA2411B	1207253	30MHz~40GHz	Jan. 28, 2015	Jul. 26, 2015	Jan. 27, 2016	Conducted (TH01-SZ)
Power Meter	Anritsu	ML2495A	1218010	50MHz Bandwidth	Jan. 28, 2015	Jul. 26, 2015	Jan. 27, 2016	Conducted (TH01-SZ)
EMI Test Receiver	R&S	ESR7	101403	9kHz~7GHz; Max 30dBm	Sep. 29, 2014	Aug. 10, 2015	Sep. 28, 2015	Radiation (03CH02-KS)
Spectrum Analyzer	R&S	FSV40	101040	10kHz~40GHz; Max 30dBm	Sep. 25, 2014	Aug. 10, 2015	Sep. 24, 2015	Radiation (03CH02-KS)
Loop Antenna	R&S	HFH2-Z2	100321	9kHz~30MHz	Nov. 13, 2014	Aug. 10, 2015	Nov. 12, 2015	Radiation (03CH02-KS)
Bilog Antenna	TeseQ	CBL6112D	37879	30MHz~2GHz	Sep. 13, 2014	Aug. 10, 2015	Sep. 12, 2015	Radiation (03CH02-KS)
Double Ridge Horn Antenna	ETS-Lindgren	3117	75957	1GHz~18GHz	Nov. 08, 2014	Aug. 10, 2015	Nov. 07, 2015	Radiation (03CH02-KS)
Active Horn Antenna	com-power	AHA-118	701030	1GHz~18GHz	Nov. 08, 2014	Aug. 10, 2015	Nov. 07, 2015	Radiation (03CH02-KS)
SHF-EHF Horn	com-power	AH-840	101070	18GHz~40GHz	Sep. 04, 2014	Aug. 10, 2015	Sep. 03, 2015	Radiation (03CH02-KS)
Amplifier	com-power	PA-103A	161069	1kHz~1000MHz / 32 dB	May 04, 2015	Aug. 10, 2015	May 03, 2016	Radiation (03CH02-KS)
Amplifier	Agilent	8449B	3008A02384	1GHz~26.5GHz Gain 30dB	Oct. 28, 2014	Aug. 10, 2015	Oct. 27, 2015	Radiation (03CH02-KS)
AC Power Source	Chroma	61601	616010002473	N/A	NCR	Aug. 10, 2015	NCR	Radiation (03CH02-KS)
Turn Table	MF	MF7802	N/A	0~360 degree	NCR	Aug. 10, 2015	NCR	Radiation (03CH02-KS)
Antenna Mast	MF	MF7802	N/A	1 m~4 m	NCR	Aug. 10, 2015	NCR	Radiation (03CH02-KS)
EMI Receiver	R&S	ESCI7	100768	9kHz~7GHz	May 04, 2015	Aug. 13, 2015	May 03, 2016	Conduction (CO01-KS)
AC LISN	MessTec	AN3016	060103	9kHz~30MHz	Oct. 25, 2014	Aug. 13, 2015	Oct. 24, 2015	Conduction (CO01-KS)
AC LISN (for auxiliary equipment)	MessTec	AN3016	060105	9kHz~30MHz	Oct. 25, 2014	Aug. 13, 2015	Oct. 24, 2015	Conduction (CO01-KS)
AC Power Source	Chroma	61602	ABP00000811	AC 0V~300V, 45Hz~1000Hz	Oct. 25, 2014	Aug. 13, 2015	Oct. 24, 2015	Conduction (CO01-KS)



## 5. Uncertainty of Evaluation

### Uncertainty of Conducted Emission Measurement (150 kHz ~ 30 MHz)

Measuring Uncertainty for a Level of Confidence of 95% ( $U = 2Uc(y)$ )	2.3 dB
---	--------

### Uncertainty of Radiated Emission Measurement (30 MHz ~ 1000 MHz)

Measuring Uncertainty for a Level of Confidence of 95% ( $U = 2Uc(y)$ )	5.1 dB
---	--------



## **Appendix A. Conducted Test Results**

Test Engineer:	Mygai Mo	Temperature:	24~26	°C
Test Date:	2015/7/26	Relative Humidity:	50~53	%



**TEST RESULTS DATA**  
**6dB and 99% Occupied Bandwidth**

2.4GHz Band								
Mod.	Data Rate	N <sub>TX</sub>	CH.	Freq. (MHz)	99% Occupied BW (MHz)	6dB BW (MHz)	6dB BW Limit (MHz)	Pass/Fail
11b	1Mbps	1	1	2412	13.40	8.04	0.50	Pass
11b	1Mbps	1	6	2437	13.25	8.04	0.50	Pass
11b	1Mbps	1	11	2462	13.25	8.52	0.50	Pass
11g	6Mbps	1	1	2412	17.75	16.32	0.50	Pass
11g	6Mbps	1	6	2437	18.25	16.36	0.50	Pass
11g	6Mbps	1	11	2462	18.25	15.98	0.50	Pass
HT20	MCS0	1	1	2412	18.55	17.56	0.50	Pass
HT20	MCS0	1	6	2437	19.00	17.56	0.50	Pass
HT20	MCS0	1	11	2462	18.90	16.92	0.50	Pass

**TEST RESULTS DATA**  
**Peak Power Table**

2.4GHz Band										
Mod.	Data Rate	N <sub>TX</sub>	CH.	Freq. (MHz)	Peak Conducted Power (dBm)	Conducted Power Limit (dBm)	DG (dBi)	EIRP Power (dBm)	EIRP Power Limit (dBm)	Pass /Fail
11b	1Mbps	1	1	2412	18.79	30.00	-0.10	18.69	36.00	Pass
11b	1Mbps	1	6	2437	18.34	30.00	-0.10	18.24	36.00	Pass
11b	1Mbps	1	11	2462	18.11	30.00	-0.10	18.01	36.00	Pass
11g	6Mbps	1	1	2412	22.03	30.00	-0.10	21.93	36.00	Pass
11g	6Mbps	1	6	2437	21.86	30.00	-0.10	21.76	36.00	Pass
11g	6Mbps	1	11	2462	21.65	30.00	-0.10	21.55	36.00	Pass
HT20	MCS0	1	1	2412	21.95	30.00	-0.10	21.85	36.00	Pass
HT20	MCS0	1	6	2437	21.89	30.00	-0.10	21.79	36.00	Pass
HT20	MCS0	1	11	2462	21.36	30.00	-0.10	21.26	36.00	Pass

**TEST RESULTS DATA**  
**Average Power Table**  
**(Reporting Only)**

2.4GHz Band						
Mod.	Data Rate	N <sub>TX</sub>	CH.	Freq. (MHz)	Duty Factor (dB)	Average Conducted Power (dBm)
11b	1Mbps	1	1	2412	0.11	15.92
11b	1Mbps	1	6	2437	0.11	15.47
11b	1Mbps	1	11	2462	0.11	15.25
11g	6Mbps	1	1	2412	0.57	12.61
11g	6Mbps	1	6	2437	0.57	12.46
11g	6Mbps	1	11	2462	0.57	12.33
HT20	MCS0	1	1	2412	0.65	11.57
HT20	MCS0	1	6	2437	0.65	11.43
HT20	MCS0	1	11	2462	0.65	11.36

**TEST RESULTS DATA**  
**Peak Power Density**

2.4GHz Band								
Mod.	Data Rate	N <sub>TX</sub>	CH.	Freq. (MHz)	Peak PSD (dBm /3kHz)	DG (dBi)	Peak PSD Limit (dBm /3kHz)	Pass/Fail
11b	1Mbps	1	1	2412	-7.01	-0.10	8.00	Pass
11b	1Mbps	1	6	2437	-6.65	-0.10	8.00	Pass
11b	1Mbps	1	11	2462	-7.20	-0.10	8.00	Pass
11g	6Mbps	1	1	2412	-12.72	-0.10	8.00	Pass
11g	6Mbps	1	6	2437	-12.34	-0.10	8.00	Pass
11g	6Mbps	1	11	2462	-13.59	-0.10	8.00	Pass
HT20	MCS0	1	1	2412	-14.31	-0.10	8.00	Pass
HT20	MCS0	1	6	2437	-13.59	-0.10	8.00	Pass
HT20	MCS0	1	11	2462	-13.40	-0.10	8.00	Pass



## Appendix B. Radiated Spurious Emission

2.4GHz 2400~2483.5MHz

WIFI 802.11b (Band Edge @ 3m)

WIFI	Note	Frequency ( MHz )	Level ( dBμV/m )	Over Limit ( dB )	Limit Line ( dBμV/m )	Read Level ( dBμV )	Antenna Factor ( dB/m )	Cable Loss ( dB )	Preamp Factor ( dB )	Ant Pos ( cm )	Table Pos ( deg )	Peak Avg. ( P/A )	Pol. ( H/V )
802.11b CH 01 2412MHz	*	2410.521	102.57	-	-	103.6	31.23	4.74	37	150	242	P	H
	*	2411.189	98.42	-	-	99.45	31.23	4.74	37	150	242	A	H
		2389.29	47.34	-26.66	74	48.44	31.2	4.72	37.02	150	242	P	H
		2389.92	34.78	-19.22	54	35.88	31.2	4.72	37.02	150	242	A	H
	*	2410.521	93.31	-	-	94.34	31.23	4.74	37	150	329	P	V
	*	2411.189	88.97	-	-	90	31.23	4.74	37	150	329	A	V
		2318.19	44.92	-29.08	74	46.16	31.13	4.64	37.01	150	329	P	V
		2389.65	31.57	-22.43	54	32.67	31.2	4.72	37.02	150	329	A	V
802.11b CH 06 2437MHz	*	2435.488	101.85	-	-	102.82	31.26	4.76	36.99	170	242	P	H
	*	2436.239	97.44	-	-	98.41	31.26	4.76	36.99	170	242	A	H
	*	2435.571	87.05	-	-	88.02	31.26	4.76	36.99	207	332	P	V
	*	2436.239	82.93	-	-	83.9	31.26	4.76	36.99	207	332	A	V
802.11b CH 11 2462MHz	*	2463.376	102.35	-	-	103.21	31.31	4.79	36.96	150	236	P	H
	*	2462.792	97.6	-	-	98.46	31.31	4.79	36.96	150	236	A	H
		2486.36	45.98	-28.02	74	46.78	31.34	4.8	36.94	150	236	P	H
		2483.52	33.79	-20.21	54	34.59	31.34	4.8	36.94	150	236	A	H
	*	2463.46	89.52	-	-	90.38	31.31	4.79	36.96	150	57	P	V
	*	2462.792	84.89	-	-	85.75	31.31	4.79	36.96	150	57	A	V
		2491.12	44.94	-29.06	74	45.68	31.37	4.82	36.93	150	57	P	V
		2493.24	31.02	-22.98	54	31.76	31.37	4.82	36.93	150	57	A	V
Remark	1. No other spurious found. 2. All results are PASS against Peak and Average limit line.												



**2.4GHz 2400~2483.5MHz  
WIFI 802.11b (Harmonic @ 3m)**

WIFI	Note	Frequency ( MHz )	Level ( dBμV/m )	Over Limit ( dB )	Limit Line ( dBμV/m )	Read Level ( dBμV )	Antenna Factor ( dB/m )	Cable Loss ( dB )	Preamp Factor ( dB )	Ant Pos ( cm )	Table Pos ( deg )	Peak Avg. ( P/A )	Pol. ( H/V )
802.11b CH 01 2412MHz		4824	54.52	-19.48	74	49.44	34.93	6.83	36.68	150	139	P	H
	!	4824	49.23	-4.77	54	44.15	34.93	6.83	36.68	150	139	A	H
		4824	49.12	-24.88	74	44.04	34.93	6.83	36.68	150	0	P	V
		4824	42.91	-11.09	54	37.83	34.93	6.83	36.68	150	0	A	V
802.11b CH 06 2437MHz		4875	55.82	-18.18	74	50.66	34.95	6.87	36.66	150	122	P	H
	!	4875	50.95	-3.05	54	45.79	34.95	6.87	36.66	150	122	A	H
		7311	47.48	-26.52	74	39.84	35.76	8.57	36.69	156	98	P	H
		4875	52.87	-21.13	74	47.71	34.95	6.87	36.66	150	9	P	V
		4875	44.95	-9.05	54	39.79	34.95	6.87	36.66	150	9	A	V
		7311	48.31	-25.69	74	40.67	35.76	8.57	36.69	153	248	P	V
802.11b CH 11 2462MHz		4923	49.02	-24.98	74	43.78	34.97	6.92	36.65	150	142	P	H
		4923	44.86	-9.14	54	39.62	34.97	6.92	36.65	150	142	A	H
		7386	48.11	-25.89	74	40.43	35.78	8.68	36.78	150	0	P	H
		4923	46.83	-27.17	74	41.59	34.97	6.92	36.65	150	360	P	V
		4923	39.11	-14.89	54	33.87	34.97	6.92	36.65	150	360	A	V
		7386	50.13	-23.87	74	42.45	35.78	8.68	36.78	150	0	P	V
<b>Remark</b>	1. No other spurious found. 2. All results are PASS against Peak and Average limit line.												



**2.4GHz 2400~2483.5MHz  
WIFI 802.11g (Band Edge @ 3m)**

WIFI	Note	Frequency ( MHz )	Level ( dBμV/m )	Over Limit ( dB )	Limit Line ( dBμV/m )	Read Level ( dBμV )	Antenna Factor ( dB/m )	Cable Loss ( dB )	Preamp Factor ( dB )	Ant Pos ( cm )	Table Pos ( deg )	Peak Avg. ( P/A )	Pol. ( H/V )
802.11g CH 01 2412MHz	*	2407.097	102.9	-	-	103.93	31.23	4.74	37	158	59	P	H
	*	2405.594	92.56	-	-	93.59	31.23	4.74	37	158	59	A	H
		2389.56	62.46	-11.54	74	63.56	31.2	4.72	37.02	158	59	P	H
		2389.92	41.11	-12.89	54	42.21	31.2	4.72	37.02	158	59	A	H
	*	2405.177	102.28	-	-	103.31	31.23	4.74	37	325	75	P	V
	*	2405.344	91.89	-	-	92.92	31.23	4.74	37	325	75	A	V
		2389.92	59.92	-14.08	74	61.02	31.2	4.72	37.02	325	75	P	V
		2389.83	40.63	-13.37	54	41.73	31.2	4.72	37.02	325	75	A	V
802.11g CH 06 2437MHz	*	2439.496	103.58	-	-	104.49	31.29	4.77	36.97	169	126	P	H
	*	2439.83	93.16	-	-	94.07	31.29	4.77	36.97	169	126	A	H
	*	2441.917	103.91	-	-	104.82	31.29	4.77	36.97	319	97	P	V
	*	2440.999	92.67	-	-	93.58	31.29	4.77	36.97	319	97	A	V
802.11g CH 11 2462MHz	*	2467.635	103.42	-	-	104.28	31.31	4.79	36.96	190	62	P	H
	*	2469.221	93.11	-	-	93.97	31.31	4.79	36.96	190	62	A	H
		2483.72	63.26	-10.74	74	64.06	31.34	4.8	36.94	190	62	P	H
		2483.64	39.08	-14.92	54	39.88	31.34	4.8	36.94	190	62	A	H
	*	2469.054	102.44	-	-	103.3	31.31	4.79	36.96	309	76	P	V
	*	2469.555	92.41	-	-	93.27	31.31	4.79	36.96	309	76	A	V
		2483.56	61.96	-12.04	74	62.76	31.34	4.8	36.94	309	76	P	V
		2483.52	37.93	-16.07	54	38.73	31.34	4.8	36.94	309	76	A	V
Remark	1. No other spurious found. 2. All results are PASS against Peak and Average limit line.												



**2.4GHz 2400~2483.5MHz  
WIFI 802.11g (Harmonic @ 3m)**

WIFI	Note	Frequency ( MHz )	Level ( dBμV/m )	Over Limit ( dB )	Limit Line ( dBμV/m )	Read Level ( dBμV )	Antenna Factor ( dB/m )	Cable Loss ( dB )	Preamp Factor ( dB )	Ant Pos ( cm )	Table Pos ( deg )	Peak Avg. ( P/A )	Pol. ( H/V )
802.11g CH 01 2412MHz		4824	48.71	-25.29	74	43.63	34.93	6.83	36.68	150	360	P	H
		4824	49.75	-24.25	74	44.67	34.93	6.83	36.68	150	0	P	V
802.11g CH 06 2437MHz		4875	49.4	-24.6	74	44.24	34.95	6.87	36.66	150	360	P	H
		7311	47.97	-26.03	74	40.33	35.76	8.57	36.69	167	89	P	H
		4875	49.6	-24.4	74	44.44	34.95	6.87	36.66	150	0	P	V
		7311	47.05	-26.95	74	39.41	35.76	8.57	36.69	289	335	P	V
802.11g CH 11 2462MHz		4923	49.25	-24.75	74	44.01	34.97	6.92	36.65	150	360	P	H
		7386	48.5	-25.5	74	40.82	35.78	8.68	36.78	156	231	P	H
		4923	49.62	-24.38	74	44.38	34.97	6.92	36.65	150	0	P	V
		7386	47.92	-26.08	74	40.24	35.78	8.68	36.78	312	98	P	V
Remark	1. No other spurious found. 2. All results are PASS against Peak and Average limit line.												





**2.4GHz 2400~2483.5MHz  
WIFI 802.11n HT20 (Band Edge @ 3m)**

WIFI	Note	Frequency ( MHz )	Level ( dBμV/m )	Over Limit ( dB )	Limit Line ( dBμV/m )	Read Level ( dBμV )	Antenna Factor ( dB/m )	Cable Loss ( dB )	Preamp Factor ( dB )	Ant Pos ( cm )	Table Pos ( deg )	Peak Avg. ( P/A )	Pol. ( H/V )
802.11n HT20 CH 01 2412MHz	*	2407.515	102	-	-	103.03	31.23	4.74	37	150	122	P	H
	*	2406.429	91.68	-	-	92.71	31.23	4.74	37	150	122	A	H
		2389.92	57.99	-16.01	74	59.09	31.2	4.72	37.02	150	122	P	H
		2389.83	38.78	-15.22	54	39.88	31.2	4.72	37.02	150	122	A	H
	*	2406.095	101.1	-	-	102.13	31.23	4.74	37	150	73	P	V
	*	2406.68	90.37	-	-	91.4	31.23	4.74	37	150	73	A	V
		2389.83	55.91	-18.09	74	57.01	31.2	4.72	37.02	150	73	P	V
	2389.92	37.99	-16.01	54	39.09	31.2	4.72	37.02	150	73	A	V	
802.11n HT20 CH 06 2437MHz	*	2441.082	102.61	-	-	103.52	31.29	4.77	36.97	163	122	P	H
	*	2438.66	91.65	-	-	92.56	31.29	4.77	36.97	163	122	A	H
	*	2440.581	102.46	-	-	103.37	31.29	4.77	36.97	317	93	P	V
	*	2440.581	91.98	-	-	92.89	31.29	4.77	36.97	317	93	A	V
802.11n HT20 CH 11 2462MHz	*	2469.555	102.17	-	-	103.03	31.31	4.79	36.96	192	60	P	H
	*	2469.639	91.93	-	-	92.79	31.31	4.79	36.96	192	60	A	H
		2484.04	62.35	-11.65	74	63.15	31.34	4.8	36.94	192	60	P	H
		2483.52	39.75	-14.25	54	40.55	31.34	4.8	36.94	192	60	A	H
	*	2469.388	101.6	-	-	102.46	31.31	4.79	36.96	303	98	P	V
	*	2469.722	91.91	-	-	92.77	31.31	4.79	36.96	303	98	A	V
		2484.6	61.08	-12.92	74	61.88	31.34	4.8	36.94	303	98	P	V
	2483.56	39.87	-14.13	54	40.67	31.34	4.8	36.94	303	98	A	V	
Remark	1. No other spurious found. 2. All results are PASS against Peak and Average limit line.												



**2.4GHz 2400~2483.5MHz  
WIFI 802.11n HT20 (Harmonic @ 3m)**

WIFI	Note	Frequency ( MHz )	Level ( dBμV/m )	Over Limit ( dB )	Limit Line ( dBμV/m )	Read Level ( dBμV )	Antenna Factor ( dB/m )	Cable Loss ( dB )	Preamp Factor ( dB )	Ant Pos ( cm )	Table Pos ( deg )	Peak Avg. ( P/A )	Pol. ( H/V )
802.11n HT20 CH 01 2412MHz		4824	46.09	-27.91	74	41.01	34.93	6.83	36.68	150	360	P	H
		4824	46.72	-27.28	74	41.64	34.93	6.83	36.68	150	0	P	V
802.11n HT20 CH 06 2437MHz		4875	46.51	-27.49	74	41.35	34.95	6.87	36.66	150	360	P	H
		7311	48.13	-25.87	74	40.49	35.76	8.57	36.69	150	268	P	H
		4875	46.04	-27.96	74	40.88	34.95	6.87	36.66	150	98	P	V
		7311	48.59	-25.41	74	40.95	35.76	8.57	36.69	150	128	P	V
802.11n HT20 CH 11 2462MHz		4923	46.78	-27.22	74	41.54	34.97	6.92	36.65	150	360	P	H
		7386	49.59	-24.41	74	41.91	35.78	8.68	36.78	150	0	P	H
		4923	46.87	-27.13	74	41.63	34.97	6.92	36.65	150	360	P	V
		7386	48.85	-25.15	74	41.17	35.78	8.68	36.78	150	0	P	V
Remark	1. No other spurious found. 2. All results are PASS against Peak and Average limit line.												



Emission below 1GHz  
2.4GHz WIFI 802.11b (LF)

WIFI	Note	Frequency ( MHz )	Level ( dBμV/m )	Over Limit ( dB )	Limit Line ( dBμV/m )	Read Level (dBμV)	Antenna Factor ( dB/m )	Cable Loss ( dB )	Preamp Factor ( dB )	Ant Pos ( cm )	Table Pos ( deg )	Peak Avg. (P/A)	Pol. (H/V)
2.4GHz 802.11b LF		30.97	19.38	-20.62	40	35.07	18.8	0.74	35.23	-	-	P	H
		218.18	31.57	-14.43	46	54.52	10.13	1.93	35.01	325	85	P	H
		288.02	26.04	-19.96	46	45.58	13.01	2.23	34.78	-	-	P	H
		340.4	26.01	-19.99	46	44.22	14.39	2.42	35.02	-	-	P	H
		400.54	27.73	-18.27	46	44.1	16.22	2.64	35.23	-	-	P	H
		421.88	30.7	-15.3	46	46.52	16.55	2.71	35.08	-	-	P	H
		30	32.81	-7.19	40	48.2	19.1	0.73	35.22	175	213	P	V
		90.14	24.15	-19.35	43.5	47.29	10.6	1.22	34.96	-	-	P	V
		158.04	22.08	-21.42	43.5	44.45	10.92	1.62	34.91	-	-	P	V
		217.21	26.88	-19.12	46	49.88	10.09	1.92	35.01	-	-	P	V
		421.88	22.95	-23.05	46	38.77	16.55	2.71	35.08	-	-	P	V
		470.38	24.34	-21.66	46	39.11	17.12	2.86	34.75	-	-	P	V
Remark	1. No other spurious found. 2. All results are PASS against limit line.												



Emission below 1GHz
2.4GHz WIFI 802.11g (LF)

Table with 14 columns: WIFI, Note, Frequency (MHz), Level (dBµV/m), Over Limit (dB), Limit Line (dBµV/m), Read Level (dBµV), Antenna Factor (dB/m), Cable Loss (dB), Preamp Factor (dB), Ant Pos (cm), Table Pos (deg), Peak Avg. (P/A), Pol. (H/V). Rows include test results for 2.4GHz 802.11g LF and a Remark section.



Emission below 1GHz

2.4GHz WIFI 802.11n HT20 (LF)

WIFI	Note	Frequency ( MHz )	Level ( dBμV/m )	Over Limit ( dB )	Limit Line ( dBμV/m )	Read Level (dBμV)	Antenna Factor ( dB/m )	Cable Loss ( dB )	Preamp Factor ( dB )	Ant Pos ( cm )	Table Pos ( deg )	Peak Avg. (P/A)	Pol. (H/V)
2.4GHz 802.11n HT20 LF		31.94	20.73	-19.27	40	36.72	18.5	0.75	35.24	-	-	P	H
		175.5	20.07	-23.43	43.5	43.03	10.28	1.71	34.95	-	-	P	H
		220.12	37.77	-8.23	46	60.62	10.21	1.94	35	150	245	P	H
		316.15	27.91	-18.09	46	46.59	13.86	2.33	34.87	-	-	P	H
		342.34	26.62	-19.38	46	44.79	14.43	2.43	35.03	-	-	P	H
		421.88	29.18	-16.82	46	45	16.55	2.71	35.08	-	-	P	H
	!	30.97	35.86	-4.14	40	51.55	18.8	0.74	35.23	-	-	P	V
	!	46.49	35.25	-4.75	40	58.97	10.15	0.9	34.77	-	-	P	V
	!	58.13	36.6	-3.4	40	64.26	6.9	1	35.56	150	96	P	V
		176.47	32.97	-10.53	43.5	55.96	10.25	1.71	34.95	-	-	P	V
		218.18	29.5	-16.5	46	52.45	10.13	1.93	35.01	-	-	P	V
	286.08	27.74	-18.26	46	47.39	12.92	2.22	34.79	-	-	P	V	
Remark	1. No other spurious found. 2. All results are PASS against limit line.												



### Note symbol

*	<b>Fundamental Frequency</b> which can be ignored. However, the level of any unwanted emissions shall not exceed the level of the fundamental frequency.
!	Test result is <b>over limit</b> line.
P/A	<b>Peak</b> or <b>Average</b>
H/V	<b>Horizontal</b> or <b>Vertical</b>



A calculation example for radiated spurious emission is shown as below:

WIFI Ant. 1+2	Note	Frequency ( MHz )	Level ( dBμV/m )	Over Limit ( dB )	Limit Line ( dBμV/m )	Read Level ( dBμV )	Antenna Factor ( dB/m )	Cable Loss ( dB )	Preamp Factor ( dB )	Ant Pos ( cm )	Table Pos ( deg )	Peak Avg. ( P/A )	Pol. ( H/V )
802.11b CH 01 2412MHz		2390	55.45	-18.55	74	54.51	32.22	4.58	35.86	103	308	P	H
		2390	43.54	-10.46	54	42.6	32.22	4.58	35.86	103	308	A	H

- 1. Level(dBμV/m) =  
Antenna Factor(dB/m) + Cable Loss(dB) + Read Level(dBμV) - Preamp Factor(dB)
- 2. Over Limit(dB) = Level(dBμV/m) – Limit Line(dBμV/m)

**For Peak Limit @ 2390MHz:**

- 1. Level(dBμV/m)  
= Antenna Factor(dB/m) + Cable Loss(dB) + Read Level(dBμV) - Preamp Factor(dB)  
= 32.22(dB/m) + 4.58(dB) + 54.51(dBμV) – 35.86 (dB)  
= 55.45 (dBμV/m)
- 2. Over Limit(dB)  
= Level(dBμV/m) – Limit Line(dBμV/m)  
= 55.45(dBμV/m) – 74(dBμV/m)  
= -18.55(dB)

**For Average Limit @ 2390MHz:**

- 1. Level(dBμV/m)  
= Antenna Factor(dB/m) + Cable Loss(dB) + Read Level(dBμV) - Preamp Factor(dB)  
= 32.22(dB/m) + 4.58(dB) + 42.6(dBμV) – 35.86 (dB)  
= 43.54 (dBμV/m)
- 2. Over Limit(dB)  
= Level(dBμV/m) – Limit Line(dBμV/m)  
= 43.54(dBμV/m) – 54(dBμV/m)  
= -10.46(dB)

Both peak and average measured complies with the limit line, so test result is “PASS”.