



FCC RF Test Report

APPLICANT : Lenovo(Shanghai) Electronics Technology Co., Ltd.
EQUIPMENT : Notebook Computer
BRAND NAME : Lenovo
MODEL NAME : Lenovo YB-J912L
FCC ID : O57YBJ912L
STANDARD : FCC Part 15 Subpart E §15.407
CLASSIFICATION : (NII) Unlicensed National Information Infrastructure

The product were integrated the WWAN module (Brand Name: Fibocom, Model Name: L850-GL, FCC ID: ZMOL850GL) and the BT/WLAN module (Brand Name: Intel®, Model Name: 8265D2W, FCC ID: PD98265D2) during the test.

This report contains data that were produced under subcontract by Laboratory SPORTON INTERNATIONAL INC.

The product was received on Jan. 03, 2018 and testing was completed on Mar. 28, 2018. We, Sporton International (Kunshan) Inc., would like to declare that the tested sample has been evaluated in accordance with the test procedures and has been in compliance with the applicable technical standards.

The test results in this report apply exclusively to the tested model / sample. Without written approval of Sporton International (Kunshan) Inc., the test report shall not be reproduced except in full.



Approved by: James Huang / Manager

Sporton International (Kunshan) Inc.

**No.3-2 Ping-Xiang Rd, Kunshan Development Zone Kunshan City Jiangsu Province 215335
China**



TABLE OF CONTENTS

REVISION HISTORY..... 3

SUMMARY OF TEST RESULT 4

1 GENERAL DESCRIPTION 5

 1.1 Applicant 5

 1.2 Manufacturer 5

 1.3 Product Feature of Equipment Under Test 5

 1.4 Product Specification of Equipment Under Test 6

 1.5 Modification of EUT 7

 1.6 Testing Location 8

 1.7 Applicable Standards 9

2 TEST CONFIGURATION OF EQUIPMENT UNDER TEST 10

 2.1 Carrier Frequency and Channel 10

 2.2 Test Mode 12

 2.3 Connection Diagram of Test System 14

 2.4 Support Unit used in test configuration and system 14

 2.5 EUT Operation Test Setup 14

3 TEST RESULT 15

 3.1 Maximum Conducted Output Power Measurement 15

 3.2 Unwanted Emissions Measurement 17

 3.3 AC Conducted Emission Measurement 23

 3.4 Automatically Discontinue Transmission 27

 3.5 Antenna Requirements 28

4 LIST OF MEASURING EQUIPMENT 29

5 UNCERTAINTY OF EVALUATION 30

APPENDIX A. CONDUCTED TEST RESULTS

APPENDIX B. RADIATED SPURIOUS EMISSION

APPENDIX C. DUTY CYCLE PLOTS

APPENDIX D. SETUP PHOTOGRAPHS



REVISION HISTORY

REPORT NO.	VERSION	DESCRIPTION	ISSUED DATE
FR810315D	Rev. 01	Initial issue of report	Mar. 30, 2018



SUMMARY OF TEST RESULT

Report Section	FCC Rule	Description	Limit	Result	Remark
-	2.1049 & 15.403(i)	26dB & 99% Bandwidth	-	Pass	1
3.1	15.407(a)	Maximum Conducted Output Power	≤ 24 dBm	Pass	-
-	15.407(a)	Power Spectral Density	≤ 11 dBm	Pass	1
3.2	15.407(b)	Unwanted Emissions	15.407(b) & 15.209(a)	Pass	Under limit 1.46 dB at 5150.00 MHz
3.3	15.207	AC Conducted Emission	15.207(a)	Pass	Under limit 12.26 dB at 0.203 MHz
3.4	15.407(c)	Automatically Discontinue Transmission	Discontinue Transmission	Pass	-
3.5	15.203 & 15.407(a)	Antenna Requirement	N/A	Pass	-
-	15.407 (h)	Dynamic Frequency Selection	15.407 (h)	Pass	2
<p>Remark 1: All conducted test items were leveraged from module RF report "160321-02.TR01" and "160321-02.TR02".</p> <p>Remark 2: DFS test items were leveraged from module RF report "160321-02.TR06".</p>					



1 General Description

1.1 Applicant

Lenovo(Shanghai) Electronics Technology Co., Ltd.
NO.68 BUILDING, 199 FENJU RD, Pilot Free Trade Zone, 200131, China

1.2 Manufacturer

Lenovo PC HK Limited
23/F, Lincoln House, Taikoo Place 979 King's Road, Quarry Bay, Hong Kong

1.3 Product Feature of Equipment Under Test

Product Feature	
Equipment	Notebook Computer
Brand Name	Lenovo
Model Name	Lenovo YB-J912L
FCC ID	O57YBJ912L
EUT supports Radios application	WCDMA/HSPA/HSPA+ (16QAM uplink is not supported)/ DC-HSDPA/LTE WLAN 2.4GHz 802.11b/g/n HT20/HT40 WLAN 5GHz 802.11a/n HT20/HT40 WLAN 5GHz 802.11ac VHT20/VHT40/VHT80 Bluetooth v3.0+EDR/ Bluetooth v4.0 LE/ Bluetooth v4.1 LE/ Bluetooth v4.2 LE
HW Version	Lenovo YB-J912L
SW Version	Windows 10
EUT Stage	Identical Prototype

Remark: The above EUT's information was declared by manufacturer. Please refer to the specifications or user's manual for more detailed description.



1.4 Product Specification of Equipment Under Test

Standards-related Product Specification	
Tx/Rx Frequency Range	5180 MHz ~ 5240 MHz 5260 MHz ~ 5320 MHz 5500 MHz ~ 5720 MHz
Maximum Output Power to Antenna	<p><5180 MHz ~ 5240 MHz> <Ant.1> 802.11a : 18.82 dBm / 0.0762 W MIMO<Ant. 1+2> 802.11n HT20 : 19.76 dBm / 0.0946 W 802.11n HT40 : 19.81 dBm / 0.0957 W 802.11ac VHT20 : 19.71 dBm / 0.0935 W 802.11ac VHT40 : 19.75 dBm / 0.0944 W 802.11ac VHT80 : 13.79 dBm / 0.0239 W</p> <p><5260 MHz ~ 5320 MHz> <Ant.1> 802.11a : 18.83 dBm / 0.0764 W MIMO<Ant. 1+2> 802.11n HT20 : 19.83 dBm / 0.0962 W 802.11n HT40 : 19.79 dBm / 0.0953 W 802.11ac VHT20 : 19.80 dBm / 0.0955 W 802.11ac VHT40 : 19.74 dBm / 0.0942 W 802.11ac VHT80 : 12.28 dBm / 0.0169 W</p> <p><5500 MHz ~ 5720 MHz > <Ant.2> 802.11a : 18.85 dBm / 0.0767 W MIMO<Ant. 1+2> 802.11n HT20 : 19.80 dBm / 0.0955 W 802.11n HT40 : 19.81 dBm / 0.0957 W 802.11ac VHT20 : 19.74 dBm / 0.0942 W 802.11ac VHT40 : 19.77 dBm / 0.0948 W 802.11ac VHT80 : 20.74 dBm / 0.1186 W</p>
Antenna Gain / Gain	<p>For PC Mode: <5150 MHz ~ 5250 MHz> <Ant. 1> : PIFA Antenna with gain 3.90 dBi <Ant. 2> : PIFA Antenna with gain 4.10 dBi <5250 MHz ~ 5350 MHz> <Ant. 1> : PIFA Antenna with gain 2.60 dBi <Ant. 2> : PIFA Antenna with gain 3.70 dBi <5470 MHz ~ 5725 MHz> <Ant. 1> : PIFA Antenna with gain 3.60 dBi <Ant. 2> : PIFA Antenna with gain 3.60 dBi</p> <p>For Pad Mode: <5150 MHz ~ 5250 MHz> <Ant. 1> : PIFA Antenna with gain 3.85 dBi <Ant. 2> : PIFA Antenna with gain 4.70 dBi <5250 MHz ~ 5350 MHz> <Ant. 1> : PIFA Antenna with gain 3.70 dBi <Ant. 2> : PIFA Antenna with gain 5.00 dBi <5470 MHz ~ 5725 MHz> <Ant. 1> : PIFA Antenna with gain 3.90 dBi</p>



	<Ant. 2> : PIFA Antenna with gain 4.60 dBi		
Antenna Function Description		Chain Port 1	Chain Port 2
	802.11a/n/ac SISO	V	V
	802.11n/ac MIMO	V	V
Type of Modulation	802.11a/n : OFDM (BPSK / QPSK / 16QAM / 64QAM) 802.11ac : OFDM (BPSK / QPSK / 16QAM / 64QAM / 256QAM)		

1.5 Modification of EUT

No modifications are made to the EUT during all test items.



1.6 Testing Location

SPORTON INTERNATIONAL INC. is accredited to ISO 17025 by Taiwan Accreditation Foundation (TAF code : 1190) and under the FCC-recognized accredited testing laboratories by Mutual Recognition Agreement (MRA) in FCC Test.

Test Site	SPORTON INTERNATIONAL INC.		
Test Site Location	No.58, Aly. 75, Ln. 564 Wenha 3rd Rd. Guishan Dist. Taoyuan City Taiwan TEL: +886-3-327-3456 FAX: +886-3-328-4978		
Test Site No.	Sporton Site No.	FCC designation No.	FCC Test Firm Registration No.
	03CH11-HY	TW0007	214511

Note:

1. The test site complies with ANSI C63.4 2014 requirement.
2. Test data subcontracted: radiated spurious emissions for section 3.2 of this report.

Sporton International (Kunshan) Inc. is accredited to ISO 17025 by National Voluntary Laboratory Accreditation Program (NVLAP code: 600155-0) and the FCC designation No is CN5013.

Test Site	Sporton International (Kunshan) Inc.		
Test Site Location	No.3-2 Ping-Xiang Rd, Kunshan Development Zone Kunshan City Jiangsu Province 215335 China TEL : +86-512-57900158 FAX : +86-512-57900958		
Test Site No.	Sporton Site No.	FCC Test Firm Registration No.	
	TH01-KS	CO01-KS	630927

Note: The test site complies with ANSI C63.4 2014 requirement.



1.7 Applicable Standards

According to the specifications of the manufacturer, the EUT must comply with the requirements of the following standards:

- ♦ FCC Part 15 Subpart E
- ♦ FCC KDB 789033 D02 General UNII Test Procedures New Rules v02r01.
- ♦ FCC KDB 662911 D01 Multiple Transmitter Output v02r01.
- ♦ ANSI C63.10-2013

Remark:

1. All test items were verified and recorded according to the standards and without any deviation during the test.
2. This EUT has also been tested and complied with the requirements of FCC Part 15, Subpart B, recorded in a separate test report.



2 Test Configuration of Equipment Under Test

- a. The EUT has been associated with peripherals and configuration operated in a manner tended to maximize its emission characteristics in a typical application. Frequency range investigated: conduction emission (150 kHz to 30 MHz), radiation emission (9 kHz to the 10th harmonic of the highest fundamental frequency or to 40 GHz, whichever is lower). For radiated measurement, pre-scanned PC and Pad mode in three orthogonal panels, X, Y, Z. The worst cases were recorded in this report.
- b. AC power line Conducted Emission was tested under maximum output power.

2.1 Carrier Frequency and Channel

Frequency Band	Channel	Freq. (MHz)	Channel	Freq. (MHz)
5150-5250 MHz Band 1 (U-NII-1)	36	5180	44	5220
	38*	5190	46*	5230
	40	5200	48	5240
	42#	5210		

Frequency Band	Channel	Freq. (MHz)	Channel	Freq. (MHz)
5250-5350 MHz Band 2 (U-NII-2A)	52	5260	60	5300
	54*	5270	62*	5310
	56	5280	64	5320
	58#	5290		

Frequency Band	Channel	Freq. (MHz)	Channel	Freq. (MHz)
5470-5725 MHz Band 3 (U-NII-2C)	100	5500	112	5560
	102*	5510	116	5580
	104	5520	132	5660
	106#	5530	134*	5670
	108	5540	136	5680
	110*	5550	140	5700



Frequency Band	Channel	Freq. (MHz)	Channel	Freq. (MHz)
TDWR Channel	118*	5590	124	5620
	120	5600	126*	5630
	122#	5610	128	5640

Frequency Band	Channel	Freq. (MHz)	Channel	Freq. (MHz)
Straddle Channel	138#	5690	144	5720
	142*	5710		

Note:

1. The above Frequency and Channel in "*" were 802.11n HT40 and 802.11ac VHT40.
2. The above Frequency and Channel in "#" were 802.11ac VHT80.



2.2 Test Mode

Final test modes are considering the modulation and worse data rates as below table.

Single Mode

Modulation	Data Rate
802.11a	6 Mbps

MIMO Mode

Modulation	Data Rate
802.11n HT20	MCS8
802.11n HT40	MCS8
802.11ac VHT20 (Covered by HT20)	MCS8
802.11ac VHT40 (Covered by HT40)	MCS8
802.11ac VHT80	MCS0

Test Cases	
AC Conducted Emission	Mode 1 : Bluetooth Link + WLAN Link(5G) + Adaptor 1 with Type C cable1 from Type C port1 + USB Link with U-Disk from Type C port2 + Play H Plane



Ch. #		Band I : 5150-5250 MHz	Band II : 5250-5350 MHz	Band III : 5470-5725MHz
		802.11a	802.11a	802.11a
L	Low	36	52	100
M	Middle	44	60	116
H	High	48	64	140
Straddle		-	-	144

Ch. #		Band I : 5150-5250 MHz	Band II : 5250-5350 MHz	Band III : 5470-5725MHz
		802.11n HT20	802.11n HT20	802.11n HT20
L	Low	36	52	100
M	Middle	44	60	116
H	High	48	64	140
Straddle		-	-	144

Ch. #		Band I : 5150-5250 MHz	Band II : 5250-5350 MHz	Band III : 5470-5725MHz
		802.11n HT40	802.11n HT40	802.11n HT40
L	Low	38	54	102
M	Middle	-	-	110
H	High	46	62	134
Straddle		-	-	142

Ch. #		Band I : 5150-5250 MHz	Band II : 5250-5350 MHz	Band III : 5470-5725MHz
		802.11ac VHT80	802.11ac VHT80	802.11ac VHT80
L	Low	-	-	106
M	Middle	42	58	-
H	High	-	-	-
Straddle		-	-	138

2.3 Connection Diagram of Test System

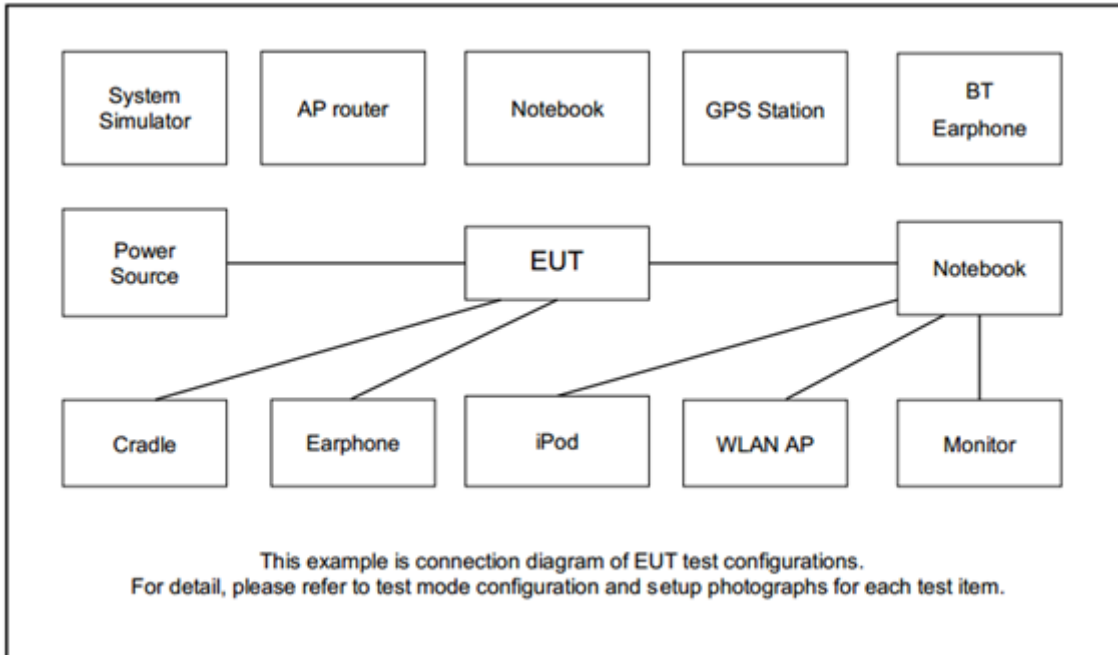

2.4 Support Unit used in test configuration and system

Item	Equipment	Trade Name	Model Name	FCC ID	Data Cable	Power Cord
1.	WLAN AP	D-link	DIR-855	KA2DIR855A2	N/A	Unshielded, 1.8 m
2.	Bluetooth Earphone	Lenovo	LBH308	N/A	N/A	N/A
3.	SD Card	Kingston	SDC4/4GB	N/A	N/A	N/A
4.	U Disk	SanDisk	SDCZ51-004G	N/A	N/A	N/A

2.5 EUT Operation Test Setup

For WLAN RF test items, an engineering test program was provided and enabled to make EUT continuous transmit/receive.

For AC power line conducted emissions, the EUT was set to connect with the WLAN AP under large package sizes transmission.



3 Test Result

3.1 Maximum Conducted Output Power Measurement

3.1.1 Limit of Maximum Conducted Output Power

<FCC 14-30 CFR 15.407>

For mobile and portable client devices in the 5.15–5.25 GHz band, the maximum conducted output power over the frequency band of operation shall not exceed 250 mW.

For the 5.25–5.725 GHz bands, the maximum conducted output power over the frequency bands of operation shall not exceed the lesser of 250 mW or $11 \text{ dBm} + 10 \log B$, where B is the 26 dB emission bandwidth in megahertz.

If transmitting antennas of directional gain greater than 6 dBi are used, the peak output power shall be reduced by the amount in dB that the directional gain of the antenna exceeds 6 dBi.

Note that U-NII-2 band, devices with a maximum e.i.r.p. greater than 500 mW shall implement TPC in order to have the capability to operate at least 6 dB below the maximum permitted e.i.r.p. of 1 W.

3.1.2 Measuring Instruments

The measuring equipment is listed in the section 4 of this test report.

3.1.3 Test Procedures

The testing follows Method PM of FCC KDB 789033 D02 General UNII Test Procedures New Rules v02r01.

Method PM (Measurement using an RF average power meter):

1. Measurement is performed using a wideband RF power meter.
2. The EUT is configured to transmit continuously with a consistent duty cycle at its maximum power control level.
3. Measure the average power of the transmitter, and the average power is corrected with duty factor, $10 \log(1/x)$, where x is the duty cycle.

3.1.4 Test Setup

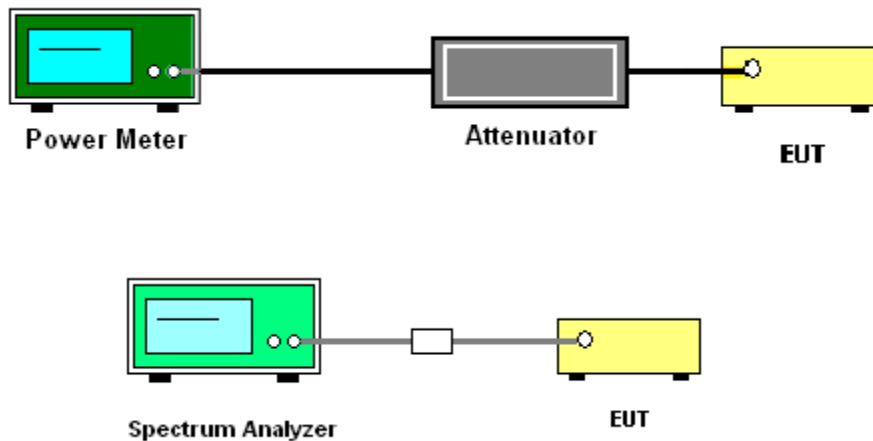

3.1.5 Test Result of Maximum Conducted Output Power

Please refer to Appendix A.



3.2 Unwanted Emissions Measurement

This section is to measure unwanted emissions through radiated measurement for band edge spurious emissions and out of band emissions measurement.

3.2.1 Limit of Unwanted Emissions

- (1) For transmitters operating in the 5150-5250 MHz band: all emissions outside of the 5150-5350 MHz band shall not exceed an EIRP of -27dBm/MHz.

For transmitters operating in the 5250-5350 MHz band: all emissions outside of the 5150-5350 MHz band shall not exceed an EIRP of -27 dBm/MHz. Devices operating in the 5250-5350 MHz band that generate emissions in the 5150-5250 MHz band must meet all applicable technical requirements for operation in the 5150-5250 MHz band (including indoor use) or alternatively meet an out-of-band emission EIRP limit of -27 dBm/MHz in the 5150-5250 MHz band.

For transmitters operating in the 5470-5600 MHz and 5650-5725MHz band: all emissions outside of the 5470-5600 MHz and 5650-5725MHz band shall not exceed an EIRP of -27 dBm/MHz.

- (2) Unwanted spurious emissions fallen in restricted bands shall comply with the general field strength limits as below table,

Frequency (MHz)	Field Strength (microvolts/meter)	Measurement Distance (meters)
0.009 – 0.490	2400/F(kHz)	300
0.490 – 1.705	24000/F(kHz)	30
1.705 – 30.0	30	30
30 – 88	100	3
88 – 216	150	3
216 - 960	200	3
Above 960	500	3

Note: The following formula is used to convert the EIRP to field strength.

$$E = \frac{1000000\sqrt{30P}}{3} \mu\text{V/m, where P is the eirp (Watts)}$$



EIRP (dBm)	Field Strength at 3m (dBµV/m)
- 27	68.3

(3) KDB789033 D02 v02r01 G)2)c)

- (i) Section 15.407(b)(1) to (b)(3) specify the unwanted emission limits for the U-NII-1 and U-NII-2 bands. As specified, emissions above 1000 MHz that are outside of the restricted bands are subject to a peak emission limit of -27 dBm/MHz.³
- (ii) Section 15.407(b)(4) specifies the unwanted emission limit for the U-NII-3 band. A band emissions mask is specified in Section 15.407(b)(4)(i). The emission limits are in terms of a Peak detector. An alternative to the band emissions mask is specified in Section 15.407(b)(4)(ii). The alternative limits are based on the highest antenna gain specified in the filing. There are also marketing and importation restrictions for the devices using the alternative limit.⁴

Note 3: An out-of-band emission that complies with both the average and peak limits of Section 15.209 is not required to satisfy the -27 dBm/MHz peak emission limit.

Note 4: Only devices with antenna gains of 10 dBi or less may be approved using the emission limits specified in Section 15.247(d) till March 2, 2018; all other devices operating in this band must use the mask specified in Section 15.407(b)(4)(i).



3.2.2 Measuring Instruments

The measuring equipment is listed in the section 4 of this test report.

3.2.3 Test Procedures

1. The testing follows FCC KDB 789033 D02 General UNII Test Procedures New Rules v02r01. Section G) Unwanted emissions measurement.

(1) Procedure for Unwanted Emissions Measurements Below 1000MHz

- RBW = 120 kHz
- VBW = 300 kHz
- Detector = Peak
- Trace mode = max hold

(2) Procedure for Peak Unwanted Emissions Measurements Above 1000 MHz

- RBW = 1 MHz
- VBW \geq 3 MHz
- Detector = Peak
- Sweep time = auto
- Trace mode = max hold

(3) Procedures for Average Unwanted Emissions Measurements Above 1000MHz

- RBW = 1 MHz
- VBW = 10 Hz, when duty cycle is no less than 98 percent.
- VBW \geq 1/T, when duty cycle is less than 98 percent where T is the minimum transmission duration over which the transmitter is on and is transmitting at its maximum power control level for the tested mode of operation.



2. The EUT was placed on a turntable with 0.8 meter for frequency below 1GHz and 1.5 meter for frequency above 1GHz respectively above ground.
3. The EUT was set 3 meters from the interference receiving antenna which was mounted on the top of a variable height antenna tower.
4. The antenna is a broadband antenna and its height is adjusted between one meter and four meters above ground to find the maximum value of the field strength for both horizontal polarization and vertical polarization of the antenna.
5. For each suspected emission, the EUT was arranged to its worst case and then adjust the antenna tower (from 1 m to 4 m) and turntable (from 0 degree to 360 degrees) to find the maximum reading.
6. For testing below 1GHz, if the emission level of the EUT in peak mode was 3 dB lower than the limit specified, then peak values of EUT will be reported, otherwise, the emissions will be repeated one by one using the CISPR quasi-peak method and reported.
7. For testing above 1GHz, the emission level of the EUT in peak mode was 20dB lower than average limit (that means the emission level in average mode also complies with the limit in average mode), then peak values of EUT will be reported, otherwise, the emissions will be measured in average mode again and reported.

3.2.4 Test Setup

For radiated emissions below 30MHz



For radiated emissions from 30MHz to 1GHz

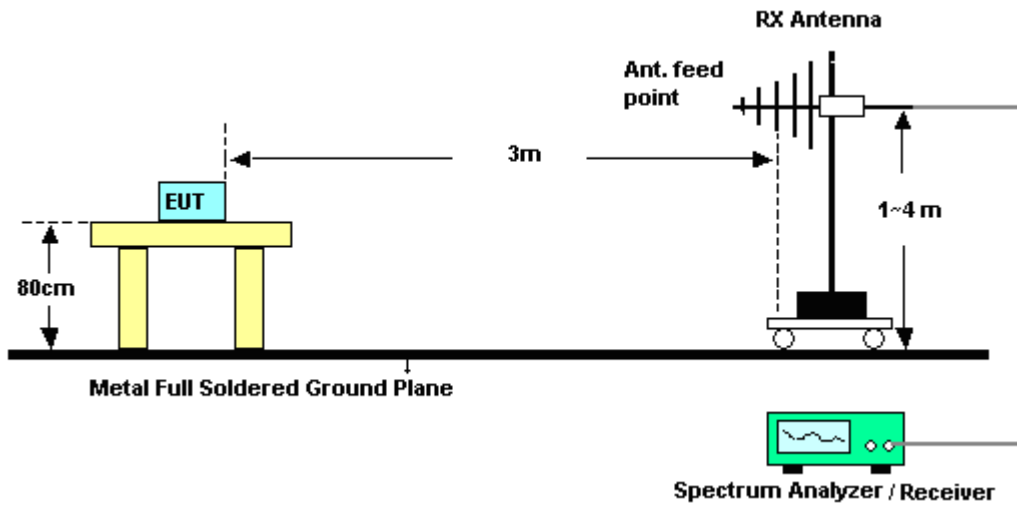

For radiated emissions above 1GHz

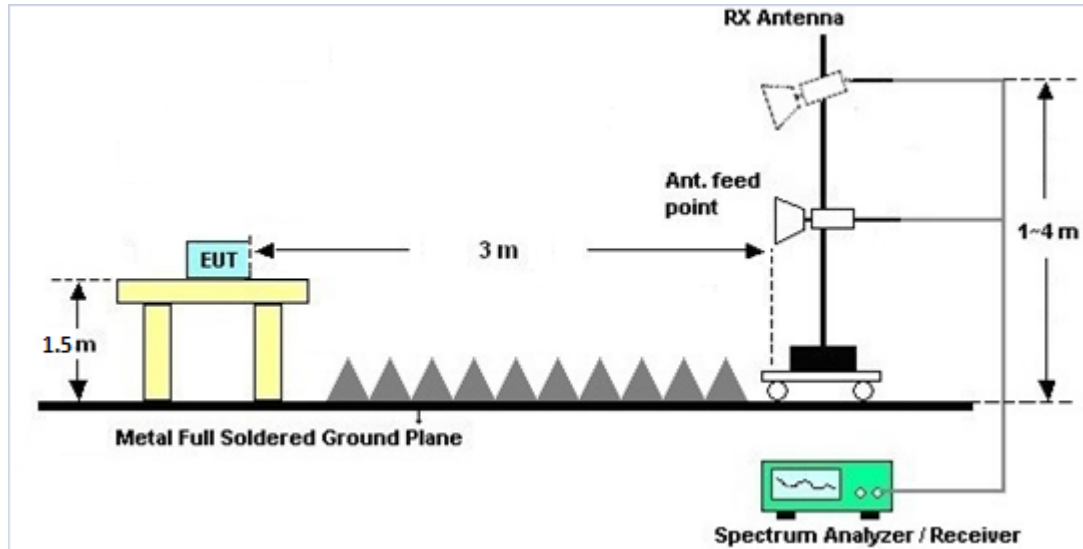

3.2.5 Test Results of Radiated Spurious Emissions (9 kHz ~ 30 MHz)

The low frequency, which started from 9 kHz to 30MHz, was pre-scanned and the result which was 20dB lower than the limit line was not reported.

There is a comparison data of both open-field test site and semi-Anechoic chamber, and the result came out very similar.

3.2.6 Test Result of Radiated Spurious at Band Edges

Please refer to Appendix B.

3.2.7 Duty Cycle

Please refer to Appendix C.

3.2.8 Test Result of Radiated Spurious Emissions (30MHz ~ 10th Harmonic)

Please refer to Appendix B.



3.3 AC Conducted Emission Measurement

3.3.1 Limit of AC Conducted Emission

For equipment that is designed to be connected to the public utility (AC) power line, the radio frequency voltage that is conducted back onto the AC power line on any frequency or frequencies within the band 150 kHz to 30 MHz shall not exceed the limits in the following table.

Frequency of emission (MHz)	Conducted limit (dBµV)	
	Quasi-peak	Average
0.15-0.5	66 to 56*	56 to 46*
0.5-5	56	46
5-30	60	50

*Decreases with the logarithm of the frequency.

3.3.2 Measuring Instruments

The measuring equipment is listed in the section 4 of this test report.

3.3.3 Test Procedures

1. The EUT was placed 0.4 meter from the conducting wall of the shielding room was kept at least 80 centimeters from any other grounded conducting surface.
2. Connect EUT to the power mains through a line impedance stabilization network (LISN).
3. All the support units are connecting to the other LISN.
4. The LISN provides 50 ohm coupling impedance for the measuring instrument.
5. The FCC states that a 50 ohm, 50 microhenry LISN should be used.
6. Both sides of AC line were checked for maximum conducted interference.
7. The frequency range from 150 kHz to 30 MHz was searched.
8. Set the test-receiver system to Peak Detect Function and specified bandwidth with Maximum Hold Mode.

3.3.4 Test Setup

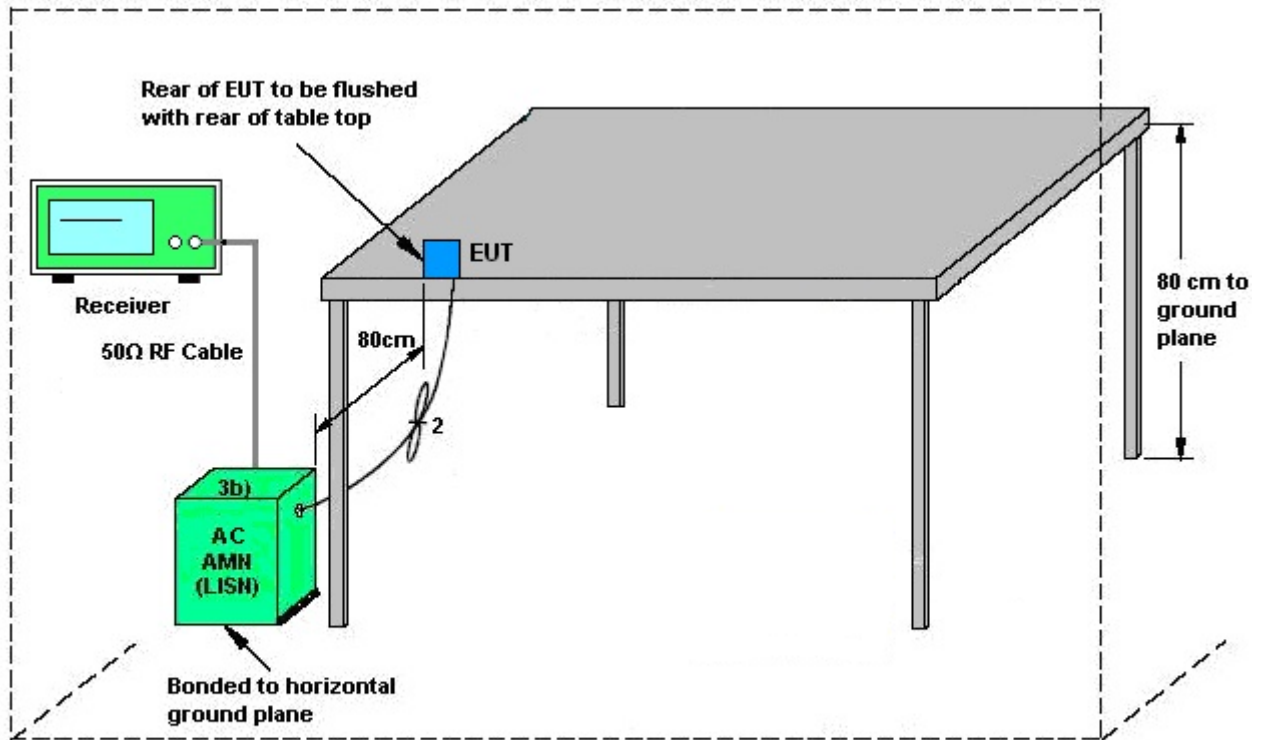

AMN = Artificial mains network (LISH)
AE = Associated equipment
EUT = Equipment under test
ISN = Impedance stabilization network



3.3.5 Test Result of AC Conducted Emission

Test Mode :	Mode 1	Temperature :	24~25°C
Test Engineer :	Amos Zhang	Relative Humidity :	37~41%
Test Voltage :	120Vac / 60Hz	Phase :	Line
Function Type :	Bluetooth Link + WLAN Link(5G) + Adaptor 1 with Type C cable1 from Type C port1 + USB Link with U-Disk from Type C port2 + Play H Plane		

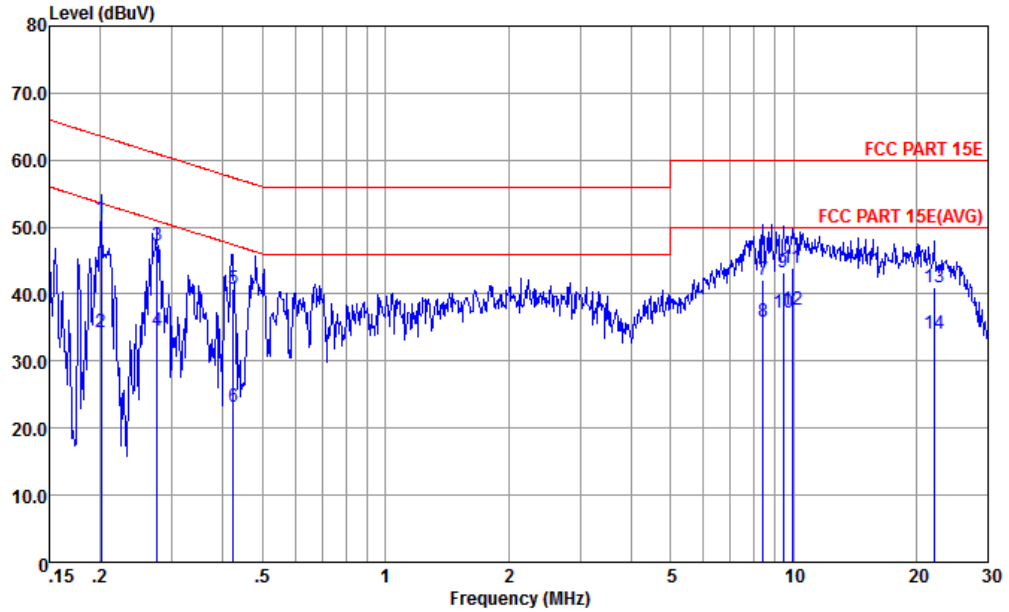

Site : CO01-KS
 Condition : FCC PART 15E LISN-L-171013-060103 LINE

	Freq	Level	Over	Limit	Read	LISN	Cable	Remark
	MHz	dBuV	Limit	Line	Level	Factor	Loss	
			dB	dBuV	dBuV	dB	dB	
1 *	0.201	51.26	-12.32	63.58	40.61	0.20	10.45	QP
2	0.201	34.26	-19.32	53.58	23.61	0.20	10.45	Average
3	0.276	47.25	-13.69	60.94	36.60	0.22	10.43	QP
4	0.276	34.45	-16.49	50.94	23.80	0.22	10.43	Average
5	0.424	40.83	-16.54	57.37	30.20	0.25	10.38	QP
6	0.424	23.23	-24.14	47.37	12.60	0.25	10.38	Average
7	8.412	42.18	-17.82	60.00	31.50	0.35	10.33	QP
8	8.412	35.88	-14.12	50.00	25.20	0.35	10.33	Average
9	9.451	43.28	-16.72	60.00	32.60	0.35	10.33	QP
10	9.451	37.28	-12.72	50.00	26.60	0.35	10.33	Average
11	9.913	43.88	-16.12	60.00	33.20	0.35	10.33	QP
12	9.913	37.58	-12.42	50.00	26.90	0.35	10.33	Average
13	22.063	41.00	-19.00	60.00	30.20	0.27	10.53	QP
14	22.063	34.10	-15.90	50.00	23.30	0.27	10.53	Average



Test Mode :	Mode 1	Temperature :	24~25°C
Test Engineer :	Amos Zhang	Relative Humidity :	37~41%
Test Voltage :	120Vac / 60Hz	Phase :	Neutral
Function Type :	Bluetooth Link + WLAN Link(5G) + Adaptor 1 with Type C cable1 from Type C port1 + USB Link with U-Disk from Type C port2 + Play H Plane		

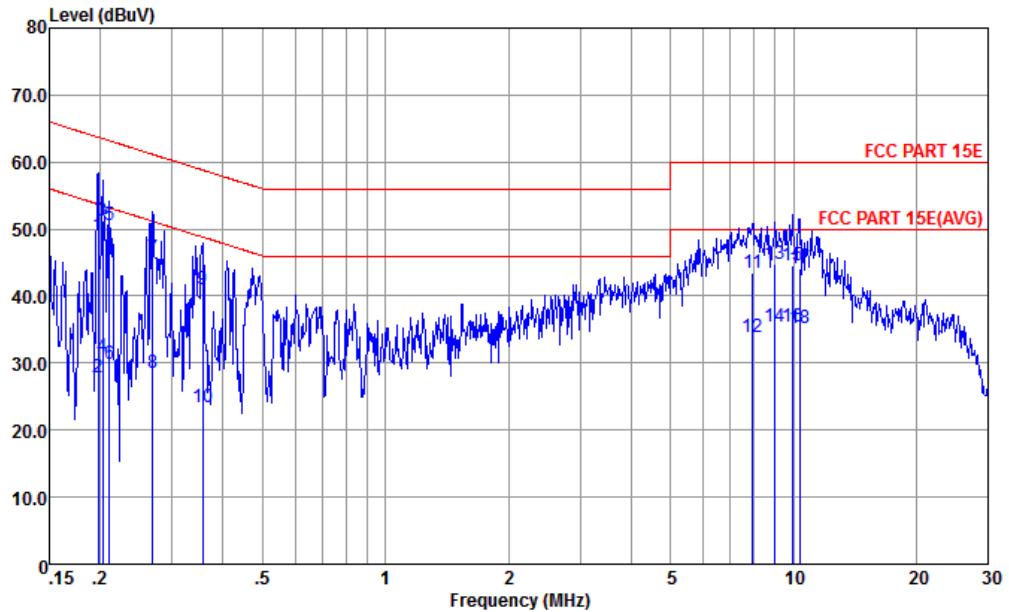

Site : CO01-KS
 Condition : FCC PART 15E LISN-N-171013-060103 NEUTRAL

	Freq	Level	Over Limit	Limit Line	Read Level	LISN Factor	Cable Loss	Remark
	MHz	dBuV	dB	dBuV	dBuV	dB	dB	
1	0.198	48.94	-14.77	63.71	38.20	0.28	10.46	QP
2	0.198	27.94	-25.77	53.71	17.20	0.28	10.46	Average
3 *	0.203	51.23	-12.26	63.49	40.50	0.28	10.45	QP
4	0.203	31.03	-22.46	53.49	20.30	0.28	10.45	Average
5	0.211	50.63	-12.55	63.18	39.90	0.28	10.45	QP
6	0.211	29.93	-23.25	53.18	19.20	0.28	10.45	Average
7	0.269	45.62	-15.54	61.16	34.91	0.28	10.43	QP
8	0.269	28.52	-22.64	51.16	17.81	0.28	10.43	Average
9	0.356	40.90	-17.93	58.83	30.19	0.29	10.42	QP
10	0.356	23.30	-25.53	48.83	12.59	0.29	10.42	Average
11	7.935	43.45	-16.55	60.00	32.81	0.31	10.33	QP
12	7.935	33.85	-16.15	50.00	23.21	0.31	10.33	Average
13	9.011	44.84	-15.16	60.00	34.20	0.31	10.33	QP
14	9.011	35.54	-14.46	50.00	24.90	0.31	10.33	Average
15	9.913	44.53	-15.47	60.00	33.90	0.30	10.33	QP
16	9.913	35.53	-14.47	50.00	24.90	0.30	10.33	Average
17	10.342	44.23	-15.77	60.00	33.60	0.29	10.34	QP
18	10.342	35.23	-14.77	50.00	24.60	0.29	10.34	Average



3.4 Automatically Discontinue Transmission

3.4.1 Limit of Automatically Discontinue Transmission

The device shall automatically discontinue transmission in case of either absence of information to transmit or operational failure. These provisions are not intended to preclude the transmission of control or signaling information or the use of repetitive codes used by certain digital technologies to complete frame or burst intervals. Applicants shall include in their application for equipment authorization to describe how this requirement is met.

3.4.2 Measuring Instruments

The measuring equipment is listed in the section 4 of this test report.

3.4.3 Test Result of Automatically Discontinue Transmission

While the EUT is not transmitting any information, the EUT can automatically discontinue transmission and become standby mode for power saving. The EUT can detect the controlling signal of ACK message transmitting from remote device and verify whether it shall resend or discontinue transmission.



3.5 Antenna Requirements

3.5.1 Standard Applicable

If transmitting antenna directional gain is greater than 6 dBi, both the peak transmit power and the peak power spectral density shall be reduced by the amount in dB that the directional gain of the antenna exceeds 6 dBi.

3.5.2 Antenna Anti-Replacement Construction

An embedded-in antenna design is used.

3.5.3 Antenna Gain

The EUT does not support CDD mode.

The antenna peak gain of EUT is less than 6 dBi. Therefore, it is not necessary to reduce maximum peak output power limit.



4 List of Measuring Equipment

Instrument	Manufacturer	Model No.	Serial No.	Characteristics	Calibration Date	Test Date	Due Date	Remark
Pulse Power Sensor	Anritsu	MA2411B	0917070	300MHz~40GHz	Jan. 18, 2018	Mar. 28, 2018	Jan. 17, 2019	Conducted (TH01-KS)
Power Meter	Anritsu	ML2495A	1005002	50MHz Bandwidth	Jan. 18, 2018	Mar. 28, 2018	Jan. 17, 2019	Conducted (TH01-KS)
Spectrum Analyzer	R&S	FSV40	101040	10Hz~40GHz	Aug. 08, 2017	Mar. 28, 2018	Aug. 07, 2018	Conducted (TH01-KS)
EMI Receiver	R&S	ESCI7	100768	9kHz~7GHz;	Apr. 20, 2017	Mar. 23, 2018	Apr. 19, 2018	Conduction (CO01-KS)
AC LISN	MessTec	AN3016	060103	9kHz~30MHz	Oct. 13, 2017	Mar. 23, 2018	Oct. 12, 2018	Conduction (CO01-KS)
AC LISN (for auxiliary equipment)	MessTec	AN3016	060105	9kHz~30MHz	Oct. 13, 2017	Mar. 23, 2018	Oct. 12, 2018	Conduction (CO01-KS)
AC Power Source	Chroma	61602	ABP00000 0811	AC 0V~300V, 45Hz~1000Hz	Oct. 12, 2017	Mar. 23, 2018	Oct. 11, 2018	Conduction (CO01-KS)
Amplifier	SONOMA	310N	187312	9kHz~1GHz	Nov. 10, 2016	Jan. 31, 2018~ Feb. 03, 2018	Nov. 09, 2018	Radiation (03CH11-HY)
Preamplifier	MITEQ	AMF-7D-0010 1800	2025787	1GHZ~18GHZ	Feb. 13, 2017	Jan. 31, 2018~ Feb. 03, 2018	Feb. 12, 2018	Radiation (03CH11-HY)
Preamplifier	Keysight	83017A	MY532700 80	1GHZ~26.5GHZ	Nov. 10, 2016	Jan. 31, 2018~ Feb. 03, 2018	Nov. 09, 2018	Radiation (03CH11-HY)
Amplifier	MITEQ	TTA1840-35- HG	1871923	18GHZ~40GHZ, VSWR : 2.5:1 max	Jul. 18, 2017	Jan. 31, 2018~ Feb. 03, 2018	Jul. 17, 2018	Radiation (03CH11-HY)
Loop Antenna	Rohde & Schwarz	HFH2-Z2	100488	9 kHz~30 MHz	Nov. 23, 2017	Jan. 31, 2018~ Feb. 03, 2018	Nov. 22, 2019	Radiation (03CH11-HY)
Bilog Antenna	TESEQ	CBL 6111D&N-6-0 6	35414&AT- N0602	30MHz~1GHz	Oct. 14, 2017	Jan. 31, 2018~ Feb. 03, 2018	Oct. 13, 2018	Radiation (03CH11-HY)
Horn Antenna	SCHWARZBE CK	BBHA 9120 D	9120D-132 6	1GHz ~ 18GHz	Oct. 16, 2017	Jan. 31, 2018~ Feb. 03, 2018	Oct. 15, 2018	Radiation (03CH11-HY)
SHF-EHF Horn Antenna	SCHWARZBE CK	BBHA 9170	BBHA9170 584	18GHz- 40GHz	Nov. 27, 2017	Jan. 31, 2018~ Feb. 03, 2018	Nov. 26, 2018	Radiation (03CH11-HY)
Hygrometer	TECPEL	DTN-303B	TP140325	N/A	Oct. 12, 2017	Jan. 31, 2018~ Feb. 03, 2018	Oct. 11, 2018	Radiation (03CH11-HY)
Spectrum Analyzer	Keysight	N9010A	MY542004 86	10Hz ~ 44GHz	Oct. 19, 2017	Jan. 31, 2018~ Feb. 03, 2018	Oct. 18, 2018	Radiation (03CH11-HY)
Controller	EMEC	EM 1000	N/A	Control Turn table & Ant Mast	N/A	Jan. 31, 2018~ Feb. 03, 2018	N/A	Radiation (03CH11-HY)
Antenna Mast	EMEC	AM-BS-4500- B	N/A	1~4m	N/A	Jan. 31, 2018~ Feb. 03, 2018	N/A	Radiation (03CH11-HY)
Turn Table	EMEC	TT 2000	N/A	0~360 Degree	N/A	Jan. 31, 2018~ Feb. 03, 2018	N/A	Radiation (03CH11-HY)

NCR: No Calibration Required



5 Uncertainty of Evaluation

Uncertainty of Conducted Emission Measurement (150kHz ~ 30MHz)

Measuring Uncertainty for a Level of Confidence of 95% ($U = 2Uc(y)$)	2.3 dB
---	--------

Uncertainty of Radiated Emission Measurement (30 MHz ~ 1000 MHz)

Measuring Uncertainty for a Level of Confidence of 95% ($U = 2Uc(y)$)	5.2 dB
---	--------

Uncertainty of Radiated Emission Measurement (1000 MHz ~ 18000 MHz)

Measuring Uncertainty for a Level of Confidence of 95% ($U = 2Uc(y)$)	5.5 dB
---	--------

Uncertainty of Radiated Emission Measurement (18000 MHz ~ 40000 MHz)

Measuring Uncertainty for a Level of Confidence of 95% ($U = 2Uc(y)$)	5.2 dB
---	--------



Appendix A. Conducted Test Results

Test Engineer:	Silent Hai	Temperature:	21~25	°C
Test Date:	2018/3/28	Relative Humidity:	51~55	%

TEST RESULTS DATA
Average Power Table

FCC Band I														
Mod.	Data Rate	NTX	CH.	Freq. (MHz)	Duty Factor (dB)		Average Conducted Power (dBm)			FCC Conducted Power Limit (dBm)		DG (dBi)		Pass/Fail
					Ant 1	Ant 2	Ant 1	Ant 2	SUM	Ant 1	Ant 2	Ant 1	Ant 2	
11a	6Mbps	1	36	5180	0.24	0.24	16.82	16.30		24.00	24.00	3.85	4.70	Pass
11a	6Mbps	1	44	5220	0.24	0.24	18.82	18.81		24.00	24.00	3.85	4.70	Pass
11a	6Mbps	1	48	5240	0.24	0.24	18.32	18.28		24.00	24.00	3.85	4.70	Pass
HT20	MCS0	1	36	5180	0.19	0.18	16.73	16.26		24.00	24.00	3.85	4.70	Pass
HT20	MCS0	1	44	5220	0.19	0.18	18.81	18.80		24.00	24.00	3.85	4.70	Pass
HT20	MCS0	1	48	5240	0.19	0.18	18.25	18.29		24.00	24.00	3.85	4.70	Pass
HT40	MCS0	1	38	5190	0.74	0.72	16.80	16.80		24.00	24.00	3.85	4.70	Pass
HT40	MCS0	1	46	5230	0.74	0.72	18.82	18.70		24.00	24.00	3.85	4.70	Pass
VHT20	MCS0	1	36	5180	0.21	0.20	16.68	16.23		24.00	24.00	3.85	4.70	Pass
VHT20	MCS0	1	44	5220	0.21	0.20	18.76	18.75		24.00	24.00	3.85	4.70	Pass
VHT20	MCS0	1	48	5240	0.21	0.20	18.22	18.25		24.00	24.00	3.85	4.70	Pass
VHT40	MCS0	1	38	5190	0.74	0.72	16.70	16.76		24.00	24.00	3.85	4.70	Pass
VHT40	MCS0	1	46	5230	0.74	0.72	18.78	18.66		24.00	24.00	3.85	4.70	Pass
VHT80	MCS0	1	42	5210	0.77	0.77	12.79	12.81		24.00	24.00	3.85	4.70	Pass
HT20	MCS0	2	36	5180	0.74	0.72	14.77	14.78	17.79	24.00		4.70		Pass
HT20	MCS0	2	44	5220	0.74	0.72	16.76	16.74	19.76	24.00		4.70		Pass
HT20	MCS0	2	48	5240	0.74	0.72	16.72	16.71	19.73	24.00		4.70		Pass
HT40	MCS0	2	38	5190	0.79	0.79	12.30	12.24	15.28	24.00		4.70		Pass
HT40	MCS0	2	46	5230	0.79	0.79	16.78	16.81	19.81	24.00		4.70		Pass
VHT20	MCS0	2	36	5180	0.40	0.40	14.74	14.73	17.75	24.00		4.70		Pass
VHT20	MCS0	2	44	5220	0.40	0.40	16.72	16.68	19.71	24.00		4.70		Pass
VHT20	MCS0	2	48	5240	0.40	0.40	16.62	16.61	19.63	24.00		4.70		Pass
VHT40	MCS0	2	38	5190	0.41	0.45	12.25	12.20	15.23	24.00		4.70		Pass
VHT40	MCS0	2	46	5230	0.41	0.45	16.72	16.77	19.75	24.00		4.70		Pass
VHT80	MCS0	2	42	5210	0.48	0.46	10.75	10.81	13.79	24.00		4.70		Pass

TEST RESULTS DATA
Average Power Table

FCC Band II															
Mod.	Data Rate	NTX	CH.	Freq. (MHz)	Duty Factor (dB)		Average Conducted Power (dBm)			FCC Conducted Power Limit (dBm)		DG (dBi)		EIRP Power Limit (dBm)	Pass/Fail
					Ant 1	Ant 2	Ant 1	Ant 2	SUM	Ant 1	Ant 2	Ant 1	Ant 2		
11a	6Mbps	1	52	5260	0.24	0.24	18.80	18.83		23.98	23.98	3.70	5.00	26.99	Pass
11a	6Mbps	1	60	5300	0.24	0.24	18.83	18.80		23.98	23.98	3.70	5.00	26.99	Pass
11a	6Mbps	1	64	5320	0.24	0.24	14.85	15.23		23.98	23.98	3.70	5.00	26.99	Pass
HT20	MCS0	1	52	5260	0.19	0.18	18.82	18.85		23.98	23.98	3.70	5.00	26.99	Pass
HT20	MCS0	1	60	5300	0.19	0.18	18.80	18.84		23.98	23.98	3.70	5.00	26.99	Pass
HT20	MCS0	1	64	5320	0.19	0.18	14.77	15.26		23.98	23.98	3.70	5.00	26.99	Pass
HT40	MCS0	1	54	5270	0.74	0.72	18.79	18.74		23.98	23.98	3.70	5.00	26.99	Pass
HT40	MCS0	1	62	5310	0.74	0.72	13.26	13.77		23.98	23.98	3.70	5.00	26.99	Pass
VHT20	MCS0	1	52	5260	0.21	0.20	18.78	18.76		23.98	23.98	3.70	5.00	26.99	Pass
VHT20	MCS0	1	60	5300	0.21	0.20	18.75	18.71		23.98	23.98	3.70	5.00	26.99	Pass
VHT20	MCS0	1	64	5320	0.21	0.20	14.75	15.14		23.98	23.98	3.70	5.00	26.99	Pass
VHT40	MCS0	1	54	5270	0.74	0.72	18.75	18.67		23.98	23.98	3.70	5.00	26.99	Pass
VHT40	MCS0	1	62	5310	0.74	0.72	13.25	13.70		23.98	23.98	3.70	5.00	26.99	Pass
VHT80	MCS0	1	58	5290	0.77	0.77	10.84	10.75		23.98	23.98	3.70	5.00	26.99	Pass
HT20	MCS0	2	52	5260	0.74	0.72	16.79	16.70	19.76	23.98		5.00		26.99	Pass
HT20	MCS0	2	60	5300	0.74	0.72	16.86	16.77	19.83	23.98		5.00		26.99	Pass
HT20	MCS0	2	64	5320	0.74	0.72	14.22	14.23	17.24	23.98		5.00		26.99	Pass
HT40	MCS0	2	54	5270	0.79	0.79	16.81	16.74	19.79	23.98		5.00		26.99	Pass
HT40	MCS0	2	62	5310	0.79	0.79	10.82	10.76	13.80	23.98		5.00		26.99	Pass
VHT20	MCS0	2	52	5260	0.40	0.40	16.76	16.65	19.72	23.98		5.00		26.99	Pass
VHT20	MCS0	2	60	5300	0.40	0.40	16.83	16.75	19.80	23.98		5.00		26.99	Pass
VHT20	MCS0	2	64	5320	0.40	0.40	14.15	14.17	17.17	23.98		5.00		26.99	Pass
VHT40	MCS0	2	54	5270	0.41	0.45	16.74	16.72	19.74	23.98		5.00		26.99	Pass
VHT40	MCS0	2	62	5310	0.41	0.45	10.69	10.68	13.69	23.98		5.00		26.99	Pass
VHT80	MCS0	2	58	5290	0.48	0.46	9.29	9.24	12.28	23.98		5.00		26.99	Pass

TEST RESULTS DATA
Average Power Table

FCC Band III															
Mod.	Data Rate	NTX	CH.	Freq. (MHz)	Duty Factor (dB)		Average Conducted Power (dBm)			FCC Conducted Power Limit (dBm)		DG (dBi)		EIRP Power Limit (dBm)	Pass/Fail
					Ant 1	Ant 2	Ant 1	Ant 2	SUM	Ant 1	Ant 2	Ant 1	Ant 2		
11a	6Mbps	1	100	5500	0.24	0.24	15.23	16.31		23.98	23.98	3.90	4.60	26.99	Pass
11a	6Mbps	1	116	5580	0.24	0.24	18.82	18.73		23.98	23.98	3.90	4.60	26.99	Pass
11a	6Mbps	1	140	5700	0.24	0.24	14.81	14.76		23.98	23.98	3.90	4.60	26.99	Pass
11a	6Mbps	1	144	5720	0.24	0.24	18.72	18.85		23.98	23.98	3.90	4.60	26.99	Pass
HT20	MCS0	1	100	5500	0.19	0.18	15.27	16.25		23.98	23.98	3.90	4.60	26.99	Pass
HT20	MCS0	1	116	5580	0.19	0.18	18.74	18.77		23.98	23.98	3.90	4.60	26.99	Pass
HT20	MCS0	1	140	5700	0.19	0.18	14.82	14.79		23.98	23.98	3.90	4.60	26.99	Pass
HT20	MCS0	1	144	5720	0.19	0.18	18.83	18.74		23.98	23.98	3.90	4.60	26.99	Pass
HT40	MCS0	1	102	5510	0.74	0.72	15.21	15.23		23.98	23.98	3.90	4.60	26.99	Pass
HT40	MCS0	1	110	5550	0.74	0.72	18.78	18.79		23.98	23.98	3.90	4.60	26.99	Pass
HT40	MCS0	1	134	5670	0.74	0.72	15.72	15.81		23.98	23.98	3.90	4.60	26.99	Pass
HT40	MCS0	1	142	5710	0.74	0.72	18.82	18.74		23.98	23.98	3.90	4.60	26.99	Pass
VHT20	MCS0	1	100	5500	0.21	0.20	15.22	16.16		23.98	23.98	3.90	4.60	26.99	Pass
VHT20	MCS0	1	116	5580	0.21	0.20	18.67	18.73		23.98	23.98	3.90	4.60	26.99	Pass
VHT20	MCS0	1	140	5700	0.21	0.20	14.77	14.73		23.98	23.98	3.90	4.60	26.99	Pass
VHT20	MCS0	1	144	5720	0.21	0.20	18.76	18.67		23.98	23.98	3.90	4.60	26.99	Pass
VHT40	MCS0	1	102	5510	0.74	0.72	15.09	15.17		23.98	23.98	3.90	4.60	26.99	Pass
VHT40	MCS0	1	110	5550	0.74	0.72	18.66	18.76		23.98	23.98	3.90	4.60	26.99	Pass
VHT40	MCS0	1	134	5670	0.74	0.72	15.67	15.74		23.98	23.98	3.90	4.60	26.99	Pass
VHT40	MCS0	1	142	5710	0.74	0.72	18.76	18.70		23.98	23.98	3.90	4.60	26.99	Pass
VHT80	MCS0	1	106	5530	0.77	0.77	12.24	12.78		23.98	23.98	3.90	4.60	26.99	Pass
VHT80	MCS0	1	122	5610	0.77	0.77	16.23	17.34		23.98	23.98	3.90	4.60	26.99	Pass
VHT80	MCS0	1	138	5690	0.77	0.77	18.80	18.82		23.98	23.98	3.90	4.60	26.99	Pass
HT20	MCS0	2	100	5500	0.74	0.72	14.76	14.72	17.75	23.98		4.60		26.99	Pass
HT20	MCS0	2	116	5580	0.74	0.72	16.78	16.69	19.75	23.98		4.60		26.99	Pass
HT20	MCS0	2	140	5700	0.74	0.72	12.76	12.76	15.77	23.98		4.60		26.99	Pass
HT20	MCS0	2	144	5720	0.74	0.72	16.79	16.79	19.80	23.98		4.60		26.99	Pass
HT40	MCS0	2	102	5510	0.79	0.79	10.78	10.80	13.80	23.98		4.60		26.99	Pass
HT40	MCS0	2	110	5550	0.79	0.79	16.77	16.82	19.81	23.98		4.60		26.99	Pass
HT40	MCS0	2	134	5670	0.79	0.79	15.25	15.27	18.27	23.98		4.60		26.99	Pass
HT40	MCS0	2	142	5710	0.79	0.79	16.82	16.76	19.80	23.98		4.60		26.99	Pass
VHT20	MCS0	2	100	5500	0.40	0.40	14.71	14.66	17.70	23.98		4.60		26.99	Pass
VHT20	MCS0	2	116	5580	0.40	0.40	16.74	16.61	19.69	23.98		4.60		26.99	Pass
VHT20	MCS0	2	140	5700	0.40	0.40	12.66	12.67	15.68	23.98		4.60		26.99	Pass
VHT20	MCS0	2	144	5720	0.40	0.40	16.70	16.76	19.74	23.98		4.60		26.99	Pass
VHT40	MCS0	2	102	5510	0.41	0.45	10.70	10.69	13.70	23.98		4.60		26.99	Pass
VHT40	MCS0	2	110	5550	0.41	0.45	16.74	16.78	19.77	23.98		4.60		26.99	Pass
VHT40	MCS0	2	134	5670	0.41	0.45	15.18	15.19	18.19	23.98		4.60		26.99	Pass
VHT40	MCS0	2	142	5710	0.41	0.45	16.77	16.67	19.73	23.98		4.60		26.99	Pass
VHT80	MCS0	2	106	5530	0.48	0.46	9.25	9.22	12.24	23.98		4.60		26.99	Pass
VHT80	MCS0	2	122	5610	0.48	0.46	16.81	16.75	19.79	23.98		4.60		26.99	Pass
VHT80	MCS0	2	138	5690	0.48	0.46	17.75	17.71	20.74	23.98		4.60		26.99	Pass



Appendix B. Radiated Spurious Emission

Band 1 - 5150~5250MHz WIFI 802.11a (Band Edge @ 3m)

WIFI Ant.	Note	Frequency	Level	Over Limit	Limit Line	Read Level	Antenna Factor	Path Loss	Preamp Factor	Ant Pos	Table Pos	Peak Avg.	Pol.
1		(MHz)	(dBμV/m)	(dB)	(dBμV/m)	(dBμV)	(dB/m)	(dB)	(dB)	(cm)	(deg)	(P/A)	(H/V)
802.11a CH 36 5180MHz		5149.24	55.06	-18.94	74	47.29	31.75	9.05	33.03	100	137	P	H
		5149.5	48.75	-5.25	54	40.98	31.75	9.05	33.03	100	137	A	H
	*	5180	110.8	-	-	102.98	31.78	9.07	33.03	100	137	P	H
	*	5180	103.26	-	-	95.44	31.78	9.07	33.03	100	137	A	H
		5145.08	55.27	-18.73	74	47.5	31.75	9.05	33.03	293	285	P	V
		5148.2	46.26	-7.74	54	38.49	31.75	9.05	33.03	293	285	A	V
	*	5180	108.27	-	-	100.45	31.78	9.07	33.03	293	285	P	V
	*	5180	100.84	-	-	93.02	31.78	9.07	33.03	293	285	A	V
802.11a CH 44 5220MHz		5148.2	53.93	-20.07	74	46.16	31.75	9.05	33.03	100	136	P	H
		5150	47.56	-6.44	54	39.79	31.75	9.05	33.03	100	136	A	H
	*	5220	113.2	-	-	105.3	31.82	9.11	33.03	100	136	P	H
	*	5220	105.75	-	-	97.85	31.82	9.11	33.03	100	136	A	H
		5456.88	52.02	-21.98	74	43.7	32.05	9.29	33.02	100	136	P	H
		5457.84	44.53	-9.47	54	36.21	32.05	9.29	33.02	100	136	A	H
		5138.84	51.42	-22.58	74	43.67	31.73	9.05	33.03	307	285	P	V
		5150	45.42	-8.58	54	37.65	31.75	9.05	33.03	307	285	A	V
	*	5220	110.38	-	-	102.48	31.82	9.11	33.03	307	285	P	V
	*	5220	102.93	-	-	95.03	31.82	9.11	33.03	307	285	A	V
		5457.84	50.4	-23.6	74	42.08	32.05	9.29	33.02	307	285	P	V
	5455.68	42.08	-11.92	54	33.76	32.05	9.29	33.02	307	285	A	V	



802.11a CH 48 5240MHz		5002.34	52.35	-21.65	74	44.86	31.6	8.93	33.04	100	137	P	H
		5001.04	45.13	-8.87	54	37.64	31.6	8.93	33.04	100	137	A	H
	*	5240	111.87	-	-	103.95	31.83	9.12	33.03	100	137	P	H
	*	5240	104.3	-	-	96.38	31.83	9.12	33.03	100	137	A	H
		5395.2	51.16	-22.84	74	42.96	32	9.22	33.02	100	137	P	H
		5351.76	43.03	-10.97	54	34.92	31.95	9.19	33.03	100	137	A	H
		5147.68	50.5	-23.5	74	42.73	31.75	9.05	33.03	303	288	P	V
		5002.86	43.97	-10.03	54	36.48	31.6	8.93	33.04	303	288	A	V
	*	5240	109.05	-	-	101.13	31.83	9.12	33.03	303	288	P	V
	*	5240	101.45	-	-	93.53	31.83	9.12	33.03	303	288	A	V
		5354.16	49.78	-24.22	74	41.67	31.95	9.19	33.03	303	288	P	V
		5402.88	40.91	-13.09	54	32.71	32	9.22	33.02	303	288	A	V
Remark	1. No other spurious found. 2. All results are PASS against Peak and Average limit line.												



Band 1 5150~5250MHz
WIFI 802.11a (Harmonic @ 3m)

WIFI Ant. 1	Note	Frequency (MHz)	Level (dBμV/m)	Over Limit (dB)	Limit Line (dBμV/m)	Read Level (dBμV)	Antenna Factor (dB/m)	Path Loss (dB)	Preamp Factor (dB)	Ant Pos (cm)	Table Pos (deg)	Peak Avg. (P/A)	Pol. (H/V)
802.11a CH 36 5180MHz		4858	54.69	-19.31	74	47.38	31.35	9.03	33.07	100	137	P	H
		4858	47.94	-6.06	54	40.63	31.35	9.03	33.07	100	137	A	H
		4942	55.5	-18.5	74	48.07	31.51	8.97	33.05	100	137	P	H
		4942	47.75	-6.25	54	40.32	31.51	8.97	33.05	100	137	A	H
		5344	52.37	-15.83	68.2	44.26	31.95	9.19	33.03	100	137	P	H
		5422	51.88	-22.12	74	43.62	32.02	9.26	33.02	100	137	P	H
		5422	44.57	-9.43	54	36.31	32.02	9.26	33.02	100	137	A	H
		5500	54.82	-13.38	68.2	46.37	32.1	9.37	33.02	100	137	P	H
		5578	54.21	-13.99	68.2	45.58	32.22	9.48	33.07	100	137	P	H
		10360	46.34	-21.86	68.2	57.09	39.51	14.63	65.2	100	0	P	H
		15540	44.56	-29.44	74	52.2	38	17.95	63.98	100	0	P	H
		4786	53.08	-20.92	74	45.99	31.23	8.94	33.08	293	285	P	V
		4786	44.23	-9.77	54	37.14	31.23	8.94	33.08	293	285	A	V
		4858	56.04	-17.96	74	48.73	31.35	9.03	33.07	293	285	P	V
		4858	47.58	-6.42	54	40.27	31.35	9.03	33.07	293	285	A	V
		4942	54.32	-19.68	74	46.89	31.51	8.97	33.05	293	285	P	V
		4942	47.88	-6.12	54	40.45	31.51	8.97	33.05	293	285	A	V
		5494	52.36	-21.64	74	43.97	32.08	9.33	33.02	293	285	P	V
	10360	48.46	-19.74	68.2	59.21	39.51	14.63	65.2	100	0	P	V	
	15540	46.3	-27.7	74	53.94	38	17.95	63.98	100	0	P	V	



802.11a CH 44 5220MHz		4816	54.37	-19.63	74	47.12	31.26	9.07	33.08	100	136	P	H
		4816	49.62	-4.38	54	42.37	31.26	9.07	33.08	100	136	A	H
		4900	57.05	-16.95	74	49.71	31.41	8.99	33.06	100	136	P	H
		4900	49.61	-4.39	54	42.27	31.41	8.99	33.06	100	136	A	H
		5542	56.92	-11.28	68.2	48.4	32.16	9.41	33.05	100	136	P	H
		5626	54.8	-13.4	68.2	46.01	32.32	9.55	33.08	100	136	P	H
		10440	43.49	-30.51	74	54.09	39.61	14.68	65.2	100	0	P	H
		15660	44.28	-29.72	74	52.44	37.67	18.06	64.24	100	0	P	H
		4822	52.76	-21.24	74	45.5	31.29	9.05	33.08	307	285	P	V
		4822	46.42	-7.58	54	39.16	31.29	9.05	33.08	307	285	A	V
		4906	56.35	-17.65	74	48.98	31.44	8.99	33.06	307	285	P	V
		4906	48.9	-5.1	54	41.53	31.44	8.99	33.06	307	285	A	V
		4978	54.57	-19.43	74	47.12	31.57	8.93	33.05	307	285	P	V
		4978	47.05	-6.95	54	39.6	31.57	8.93	33.05	307	285	A	V
		5542	53.57	-14.63	68.2	45.05	32.16	9.41	33.05	307	285	P	V
		10440	47.89	-20.31	68.2	58.49	39.61	14.68	65.2	100	0	P	V
		15660	46.84	-27.16	74	55	37.67	18.06	64.24	100	0	P	V



802.11a CH 48 5240MHz		4846	52.93	-21.07	74	45.63	31.32	9.05	33.07	100	137	P	H
		4846	49.21	-4.79	54	41.91	31.32	9.05	33.07	100	137	A	H
		4924	54.36	-19.64	74	46.95	31.48	8.99	33.06	100	137	P	H
		4924	50.64	-3.36	54	43.23	31.48	8.99	33.06	100	137	A	H
		5560	56.22	-11.98	68.2	47.65	32.19	9.44	33.06	100	137	P	H
		10480	44.06	-24.14	68.2	54.55	39.68	14.72	65.2	100	0	P	H
		15720	43.65	-30.35	74	52.14	37.47	18.1	64.39	100	0	P	H
		4840	53.3	-20.7	74	46	31.32	9.05	33.07	303	288	P	V
		4840	45.23	-8.77	54	37.93	31.32	9.05	33.07	303	288	A	V
		4918	54.48	-19.52	74	47.11	31.44	8.99	33.06	303	288	P	V
		4918	47.34	-6.66	54	39.97	31.44	8.99	33.06	303	288	A	V
		5554	52.72	-15.48	68.2	44.15	32.19	9.44	33.06	303	288	P	V
		10480	46.15	-22.05	68.2	56.64	39.68	14.72	65.2	100	0	P	V
		15720	45.07	-28.93	74	53.56	37.47	18.1	64.39	100	0	P	V
Remark	<ol style="list-style-type: none"> 1. No other spurious found. 2. All results are PASS against Peak and Average limit line. 												



Band 2 - 5250~5350MHz
WIFI 802.11a (Band Edge @ 3m)

WIFI	Note	Frequency	Level	Over	Limit	Read	Antenna	Path	Preamp	Ant	Table	Peak	Pol.
Ant.				Limit	Line	Level	Factor	Loss	Factor	Pos	Pos	Avg.	
1		(MHz)	(dBμV/m)	(dB)	(dBμV/m)	(dBμV)	(dB/m)	(dB)	(dB)	(cm)	(deg)	(P/A)	(H/V)
802.11a CH 52 5260MHz		5101.32	51.26	-22.74	74	43.59	31.7	9.01	33.04	107	123	P	H
		5016.32	43.77	-10.23	54	36.24	31.62	8.95	33.04	107	123	A	H
	*	5260	112.81	-	-	104.85	31.87	9.12	33.03	107	123	P	H
	*	5260	104.26	-	-	96.3	31.87	9.12	33.03	107	123	A	H
		5354.4	52.8	-21.2	74	44.69	31.95	9.19	33.03	107	123	P	H
		5350.08	45.73	-8.27	54	37.62	31.95	9.19	33.03	107	123	A	H
		5021.76	50.25	-23.75	74	42.71	31.63	8.95	33.04	334	292	P	V
		5016.66	43.25	-10.75	54	35.72	31.62	8.95	33.04	334	292	A	V
	*	5260	108.92	-	-	100.96	31.87	9.12	33.03	334	292	P	V
	*	5260	100.51	-	-	92.55	31.87	9.12	33.03	334	292	A	V
		5361.84	49.89	-24.11	74	41.76	31.97	9.19	33.03	334	292	P	V
		5350.56	41.43	-12.57	54	33.32	31.95	9.19	33.03	334	292	A	V
802.11a CH 60 5300MHz		5143.14	50.53	-23.47	74	42.76	31.75	9.05	33.03	100	122	P	H
		5057.8	42.54	-11.46	54	34.92	31.67	8.99	33.04	100	122	A	H
	*	5300	113	-	-	104.97	31.9	9.16	33.03	100	122	P	H
	*	5300	104.29	-	-	96.26	31.9	9.16	33.03	100	122	A	H
		5350.8	57.24	-16.76	74	49.13	31.95	9.19	33.03	100	122	P	H
		5350.56	48.42	-5.58	54	40.31	31.95	9.19	33.03	100	122	A	H
		5058.14	50.19	-23.81	74	42.57	31.67	8.99	33.04	309	294	P	V
		5055.42	42.38	-11.62	54	34.76	31.67	8.99	33.04	309	294	A	V
	*	5300	108.31	-	-	100.28	31.9	9.16	33.03	309	294	P	V
	*	5300	99.89	-	-	91.86	31.9	9.16	33.03	309	294	A	V
		5352.72	51.98	-22.02	74	43.87	31.95	9.19	33.03	309	294	P	V
		5350.32	44.63	-9.37	54	36.52	31.95	9.19	33.03	309	294	A	V



802.11a CH 64 5320MHz	*	5320	108.98	-	-	100.92	31.92	9.17	33.03	100	122	P	H
	*	5320	100.75	-	-	92.69	31.92	9.17	33.03	100	122	A	H
		5350.72	55.86	-18.14	74	47.75	31.95	9.19	33.03	100	122	P	H
		5350.08	46.98	-7.02	54	38.87	31.95	9.19	33.03	100	122	A	H
	*	5320	103.99	-	-	95.93	31.92	9.17	33.03	345	272	P	V
	*	5320	95.82	-	-	87.76	31.92	9.17	33.03	345	272	A	V
		5369.6	50.62	-23.38	74	42.48	31.97	9.2	33.03	345	272	P	V
		5350.08	43.47	-10.53	54	35.36	31.95	9.19	33.03	345	272	A	V
Remark	<ol style="list-style-type: none"> No other spurious found. All results are PASS against Peak and Average limit line. 												



Band 2 5250~5350MHz
WIFI 802.11a (Harmonic @ 3m)

WIFI Ant. 1	Note	Frequency (MHz)	Level (dBμV/m)	Over Limit (dB)	Limit Line (dBμV/m)	Read Level (dBμV)	Antenna Factor (dB/m)	Path Loss (dB)	Preamp Factor (dB)	Ant Pos (cm)	Table Pos (deg)	Peak Avg. (P/A)	Pol. (H/V)
802.11a CH 52 5260MHz		4858	58.2	-15.8	74	50.89	31.35	9.03	33.07	100	247	P	H
		4858	48.25	-5.75	54	40.94	31.35	9.03	33.07	100	247	A	H
		4942	58.21	-15.79	74	50.78	31.51	8.97	33.05	100	244	P	H
		4942	48.42	-5.58	54	40.99	31.51	8.97	33.05	100	244	A	H
		5500	53.88	-14.32	68.2	45.43	32.1	9.37	33.02	107	123	P	H
		5578	58.45	-9.75	68.2	49.82	32.22	9.48	33.07	107	123	P	H
		5662	54.62	-13.58	68.2	45.67	32.38	9.68	33.11	107	123	P	H
		5746	53.38	-14.82	68.2	44.12	32.53	9.88	33.15	107	123	P	H
		10520	44.81	-23.39	68.2	55.25	39.71	14.74	65.2	100	0	P	H
		15780	44.39	-29.61	74	53.11	37.33	18.15	64.51	100	0	P	H
		4858	55.2	-18.8	74	47.89	31.35	9.03	33.07	312	301	P	V
		4858	44.41	-9.59	54	37.1	31.35	9.03	33.07	312	301	A	V
		4942	54.95	-19.05	74	47.52	31.51	8.97	33.05	100	88	P	V
		4942	44.32	-9.68	54	36.89	31.51	8.97	33.05	100	88	A	V
		5020	54.38	-19.62	74	46.85	31.62	8.95	33.04	107	87	P	V
		5020	43.45	-10.55	54	35.92	31.62	8.95	33.04	107	87	A	V
		5578	51.39	-16.81	68.2	42.76	32.22	9.48	33.07	334	292	P	V
		10520	46.06	-22.14	68.2	56.5	39.71	14.74	65.2	100	0	P	V
	15780	45.6	-28.4	74	54.32	37.33	18.15	64.51	100	0	P	V	



802.11a CH 60 5300MHz		4906	47.98	-26.02	74	40.61	31.44	8.99	33.06	100	248	P	H
		4906	57.68	-16.32	74	50.31	31.44	8.99	33.06	100	248	P	H
		4984	46.78	-27.22	74	39.33	31.57	8.93	33.05	100	246	P	H
		4984	56.5	-17.5	74	49.05	31.57	8.93	33.05	100	246	P	H
		5062	55.88	-18.12	74	48.26	31.67	8.99	33.04	100	97	P	H
		5062	44.83	-9.17	54	37.21	31.67	8.99	33.04	100	97	A	H
		5464	53.35	-14.85	68.2	45.01	32.07	9.29	33.02	100	122	P	H
		5542	53.76	-14.44	68.2	45.24	32.16	9.41	33.05	100	122	P	H
		5620	54.16	-14.04	68.2	45.37	32.32	9.55	33.08	100	122	P	H
		5704	53.38	-14.82	68.2	44.28	32.47	9.75	33.12	100	122	P	H
		10600	43.53	-30.47	74	53.82	39.78	14.8	65.18	100	0	P	H
		15900	42.8	-31.2	74	52.05	36.99	18.25	64.77	100	0	P	H
		4906	53.73	-20.27	74	46.36	31.44	8.99	33.06	100	89	P	V
		4906	43.39	-10.61	54	36.02	31.44	8.99	33.06	100	89	A	V
		4978	54.54	-19.46	74	47.09	31.57	8.93	33.05	100	88	P	V
		4978	43.88	-10.12	54	36.43	31.57	8.93	33.05	100	88	A	V
		5056	53.58	-20.42	74	45.96	31.67	8.99	33.04	100	119	P	V
		5056	42.45	-11.55	54	34.83	31.67	8.99	33.04	100	119	A	V
		10600	47.31	-26.69	74	57.6	39.78	14.8	65.18	100	0	P	V
		15900	44.09	-29.91	74	53.34	36.99	18.25	64.77	100	0	P	V



802.11a CH 64 5320MHz		4918	55.31	-18.69	74	47.94	31.44	8.99	33.06	100	249	P	H
		4918	44.97	-9.03	54	37.6	31.44	8.99	33.06	100	249	A	H
		5002	55.07	-18.93	74	47.58	31.6	8.93	33.04	100	253	P	H
		5002	44.72	-9.28	54	37.23	31.6	8.93	33.04	100	253	A	H
		5644	51.85	-16.35	68.2	42.99	32.35	9.61	33.1	100	122	P	H
		5722	52.2	-16	68.2	43.02	32.5	9.81	33.13	100	122	P	H
		10640	43.07	-30.93	74	53.31	39.81	14.82	65.17	100	0	P	H
		15960	43.51	-30.49	74	53.07	36.8	18.3	64.92	100	0	P	H
		10640	43.72	-30.28	74	53.96	39.81	14.82	65.17	100	0	P	V
		15960	44.14	-29.86	74	53.7	36.8	18.3	64.92	100	0	P	V

Remark

- No other spurious found.
- All results are PASS against Peak and Average limit line.



Band 3 - 5470~5725MHz
WIFI 802.11a (Band Edge @ 3m)

WIFI	Note	Frequency	Level	Over	Limit	Read	Antenna	Path	Preamp	Ant	Table	Peak	Pol.
Ant.				Limit	Line	Level	Factor	Loss	Factor	Pos	Pos	Avg.	
1		(MHz)	(dBμV/m)	(dB)	(dBμV/m)	(dBμV)	(dB/m)	(dB)	(dB)	(cm)	(deg)	(P/A)	(H/V)
802.11a CH 100 5500MHz		5450.64	53.52	-20.48	74	45.2	32.05	9.29	33.02	105	119	P	H
		5462.64	53.88	-14.32	68.2	45.54	32.07	9.29	33.02	105	119	P	H
		5458.8	44.48	-9.52	54	36.16	32.05	9.29	33.02	105	119	P	H
	*	5500	107.67	-	-	99.22	32.1	9.37	33.02	105	119	P	H
	*	5500	100.31	-	-	91.86	32.1	9.37	33.02	105	119	A	H
		5454	50.42	-23.58	74	42.1	32.05	9.29	33.02	310	282	P	V
		5461.36	51.8	-16.4	68.2	43.48	32.05	9.29	33.02	310	282	P	V
		5458.64	41.98	-12.02	54	33.66	32.05	9.29	33.02	310	282	P	V
	*	5500	103.72	-	-	95.27	32.1	9.37	33.02	310	282	P	V
	*	5500	95.85	-	-	87.4	32.1	9.37	33.02	310	282	A	V
802.11a CH 116 5580MHz		5418.4	51.28	-22.72	74	43.06	32.02	9.22	33.02	103	130	P	H
		5469.28	51.95	-16.25	68.2	43.61	32.07	9.29	33.02	103	130	P	H
		5423.44	42.85	-11.15	54	34.59	32.02	9.26	33.02	103	130	P	H
	*	5580	112.39	-	-	103.76	32.22	9.48	33.07	103	130	P	H
	*	5580	104.94	-	-	96.31	32.22	9.48	33.07	103	130	A	H
		5736.335	51.28	-16.92	68.2	42.02	32.53	9.88	33.15	103	130	P	H
		5449.36	49.98	-24.02	74	41.66	32.05	9.29	33.02	334	279	P	V
		5465.2	49.88	-18.32	68.2	41.54	32.07	9.29	33.02	334	279	P	V
		5422.72	41.66	-12.34	54	33.4	32.02	9.26	33.02	334	279	P	V
	*	5580	107.76	-	-	99.13	32.22	9.48	33.07	334	279	P	V
	*	5580	100.33	-	-	91.7	32.22	9.48	33.07	334	279	A	V
	5751.455	49.08	-19.12	68.2	39.82	32.53	9.88	33.15	334	279	P	V	



802.11a CH 140 5700MHz	*	5700	109.75	-	-	100.68	32.44	9.75	33.12	102	131	P	H
	*	5700	102.29	-	-	93.22	32.44	9.75	33.12	102	131	A	H
		5725.72	61.72	-6.48	68.2	52.54	32.5	9.81	33.13	102	131	P	H
	*	5700	103.32	-	-	94.25	32.44	9.75	33.12	339	282	P	V
	*	5700	95.54	-	-	86.47	32.44	9.75	33.12	339	282	A	V
		5725	51.58	-16.62	68.2	42.4	32.5	9.81	33.13	339	282	P	V
Remark	1. No other spurious found. 2. All results are PASS against Peak and Average limit line.												



Band 3 - 5470~5725MHz
WIFI 802.11a (Harmonic @ 3m)

WIFI Ant. 1	Note	Frequency (MHz)	Level (dBμV/m)	Over Limit (dB)	Limit Line (dBμV/m)	Read Level (dBμV)	Antenna Factor (dB/m)	Path Loss (dB)	Preamp Factor (dB)	Ant Pos (cm)	Table Pos (deg)	Peak Avg. (P/A)	Pol. (H/V)
802.11a CH 100 5500MHz		11000	46.67	-27.33	74	56.29	40.1	15.08	65.1	100	0	P	H
		16500	45.29	-22.91	68.2	52.85	38.5	18.74	65.1	100	0	P	H
		11000	47.29	-26.71	74	56.91	40.1	15.08	65.1	100	0	P	V
		16500	45.27	-22.93	68.2	52.83	38.5	18.74	65.1	100	0	P	V
802.11a CH 116 5580MHz		11160	55.17	-18.83	74	64.81	40.07	15.2	65.2	100	259	P	H
		11160	45.51	-8.49	54	55.15	40.07	15.2	65.2	100	259	A	H
		16740	44.68	-23.52	68.2	51.21	39.08	18.93	64.86	100	0	P	H
		11160	59.88	-14.12	74	69.52	40.07	15.2	65.2	100	102	P	V
		11160	48.16	-5.84	54	57.8	40.07	15.2	65.2	100	102	A	V
		16740	48.76	-19.44	68.2	55.29	39.08	18.93	64.86	100	0	P	V
802.11a CH 140 5700MHz		11400	46.52	-27.48	74	56.18	40.02	15.38	65.34	100	0	P	H
		17100	51.08	-17.12	68.2	55.95	40.06	19.18	64.46	100	0	P	H
		11400	46.76	-27.24	74	56.42	40.02	15.38	65.34	100	0	P	V
		17100	54.39	-13.81	68.2	59.26	40.06	19.18	64.46	100	0	P	V
Remark	1. No other spurious found. 2. All results are PASS against Peak and Average limit line.												



Band 3 - Straddle Channel
WIFI 802.11a (Band Edge @ 3m)

Table with 14 columns: WIFI, Note, Frequency, Level, Over, Limit, Read, Antenna, Path, Preamp, Ant, Table, Peak, Pol. It contains test data for 802.11a CH 144 at 5720MHz and a Remark section.



Band 3 - Straddle Channel
WIFI 802.11a (Harmonic @ 3m)

Table with 14 columns: WIFI Ant. 1, Note, Frequency (MHz), Level (dBµV/m), Over Limit (dB), Limit Line (dBµV/m), Read Level (dBµV), Antenna Factor (dB/m), Path Loss (dB), Preamp Factor (dB), Ant Pos (cm), Table Pos (deg), Peak Avg. (P/A), Pol. (H/V). Rows include frequencies from 5320 to 17160 MHz and a Remark section.



Band 1 - 5150~5250MHz

WIFI 802.11n HT20 (Band Edge @ 3m)

WIFI	Note	Frequency	Level	Over	Limit	Read	Antenna	Path	Preamp	Ant	Table	Peak	Pol.
Ant.				Limit	Line	Level	Factor	Loss	Factor	Pos	Pos	Avg.	
1+2		(MHz)	(dBμV/m)	(dB)	(dBμV/m)	(dBμV)	(dB/m)	(dB)	(dB)	(cm)	(deg)	(P/A)	(H/V)
802.11n HT20 CH 36 5180MHz		5137.02	56.02	-17.98	74	48.27	31.73	9.05	33.03	116	243	P	H
		5149.76	48.6	-5.4	54	40.83	31.75	9.05	33.03	116	243	A	H
	*	5180	112.72	-	-	104.9	31.78	9.07	33.03	116	243	P	H
	*	5180	105.23	-	-	97.41	31.78	9.07	33.03	116	243	A	H
		5138.58	52.83	-21.17	74	45.08	31.73	9.05	33.03	302	276	P	V
		5149.24	45.89	-8.11	54	38.12	31.75	9.05	33.03	302	276	A	V
	*	5180	109.59	-	-	101.77	31.78	9.07	33.03	302	276	P	V
	*	5180	102.37	-	-	94.55	31.78	9.07	33.03	302	276	A	V
802.11n HT20 CH 44 5220MHz		5148.2	53.46	-20.54	74	45.69	31.75	9.05	33.03	100	246	P	H
		5149.24	46.62	-7.38	54	38.85	31.75	9.05	33.03	100	246	A	H
	*	5220	114.56	-	-	106.66	31.82	9.11	33.03	100	246	P	H
	*	5220	107.2	-	-	99.3	31.82	9.11	33.03	100	246	A	H
		5375.04	51.86	-22.14	74	43.71	31.97	9.2	33.02	100	246	P	H
		5383.68	44.36	-9.64	54	36.2	31.98	9.2	33.02	100	246	A	H
		5146.38	51.6	-22.4	74	43.83	31.75	9.05	33.03	335	278	P	V
		5147.94	43.42	-10.58	54	35.65	31.75	9.05	33.03	335	278	A	V
	*	5220	111.75	-	-	103.85	31.82	9.11	33.03	335	278	P	V
	*	5220	103.95	-	-	96.05	31.82	9.11	33.03	335	278	A	V
	5454	50.11	-23.89	74	41.79	32.05	9.29	33.02	335	278	P	V	
	5377.44	42.32	-11.68	54	34.17	31.97	9.2	33.02	335	278	A	V	



802.11n HT20 CH 48 5240MHz		5139.62	51.55	-22.45	74	43.78	31.75	9.05	33.03	100	139	P	H
		5004.16	44.81	-9.19	54	37.28	31.62	8.95	33.04	100	139	A	H
	*	5240	114.45	-	-	106.53	31.83	9.12	33.03	100	139	P	H
	*	5240	107.04	-	-	99.12	31.83	9.12	33.03	100	139	A	H
		5360.88	52.71	-21.29	74	44.58	31.97	9.19	33.03	100	139	P	H
		5398.08	43.76	-10.24	54	35.56	32	9.22	33.02	100	139	A	H
		5005.98	48.89	-25.11	74	41.36	31.62	8.95	33.04	302	307	P	V
		5001.04	42.05	-11.95	54	34.56	31.6	8.93	33.04	302	307	A	V
	*	5240	109.5	-	-	101.58	31.83	9.12	33.03	302	307	P	V
	*	5240	102.01	-	-	94.09	31.83	9.12	33.03	302	307	A	V
		5400.96	48.64	-25.36	74	40.44	32	9.22	33.02	302	307	P	V
		5400.96	40.88	-13.12	54	32.68	32	9.22	33.02	302	307	A	V
Remark	1. No other spurious found. 2. All results are PASS against Peak and Average limit line.												



Band 1 5150~5250MHz
WIFI 802.11n HT20 (Harmonic @ 3m)

Table with 14 columns: WIFI Ant. 1+2, Note, Frequency (MHz), Level (dBµV/m), Over Limit (dB), Limit Line (dBµV/m), Read Level (dBµV), Antenna Factor (dB/m), Path Loss (dB), Preamp Factor (dB), Ant Pos (cm), Table Pos (deg), Peak Avg. (P/A), Pol. (H/V). Rows include frequencies like 4864, 4936, 5500, 5578, 10360, 15540, 4858, 4942, 10360, 15540.



802.11n HT20 CH 44 5300MHz		4906	57.2	-16.8	74	49.83	31.44	8.99	33.06	100	246	P	H
		4906	49.41	-4.59	54	42.04	31.44	8.99	33.06	100	246	A	H
		4978	56.22	-17.78	74	48.77	31.57	8.93	33.05	100	246	P	H
		4978	48.96	-5.04	54	41.51	31.57	8.93	33.05	100	246	A	H
		5536	54.45	-13.75	68.2	45.93	32.16	9.41	33.05	100	246	P	H
		10440	46.09	-22.11	68.2	56.69	39.61	14.68	65.2	100	0	P	H
		15660	45.18	-28.82	74	53.34	37.67	18.06	64.24	100	0	P	H
		4894	53.49	-20.51	74	46.13	31.41	9.01	33.06	335	278	P	V
		4894	45.97	-8.03	54	38.61	31.41	9.01	33.06	335	278	A	V
		4978	53.97	-20.03	74	46.52	31.57	8.93	33.05	335	278	P	V
		4978	45.97	-8.03	54	38.52	31.57	8.93	33.05	335	278	A	V
		5542	54.33	-13.87	68.2	45.81	32.16	9.41	33.05	335	278	P	V
		10440	47.18	-21.02	68.2	57.78	39.61	14.68	65.2	100	0	P	V
		15660	46.98	-27.02	74	55.14	37.67	18.06	64.24	100	0	P	V



802.11n HT20 CH 48 5320MHz		4840	53.66	-20.34	74	46.36	31.32	9.05	33.07	100	139	P	H
		4840	46.53	-7.47	54	39.23	31.32	9.05	33.07	100	139	A	H
		4924	54.98	-19.02	74	47.57	31.48	8.99	33.06	100	139	P	H
		4924	48.55	-5.45	54	41.14	31.48	8.99	33.06	100	139	A	H
		4996	55.18	-18.82	74	47.69	31.6	8.93	33.04	100	139	P	H
		4996	46.59	-7.41	54	39.1	31.6	8.93	33.04	100	139	A	H
		5476	52.85	-15.35	68.2	44.47	32.07	9.33	33.02	100	139	P	H
		5560	54.59	-13.61	68.2	46.02	32.19	9.44	33.06	100	139	P	H
		10480	46.52	-21.68	68.2	57.01	39.68	14.72	65.2	100	0	P	H
		15720	44.06	-29.94	74	52.55	37.47	18.1	64.39	100	0	P	H
		10480	47.77	-20.43	68.2	58.26	39.68	14.72	65.2	100	0	P	V
		15720	45.1	-28.9	74	53.59	37.47	18.1	64.39	100	0	P	V
Remark	1. No other spurious found. 2. All results are PASS against Peak and Average limit line.												



5150~5250MHz

WIFI 802.11n HT40 (Band Edge @ 3m)

WIFI Ant. 1+2	Note	Frequency (MHz)	Level (dBμV/m)	Over Limit (dB)	Limit Line (dBμV/m)	Read Level (dBμV)	Antenna Factor (dB/m)	Path Loss (dB)	Preamp Factor (dB)	Ant Pos (cm)	Table Pos (deg)	Peak Avg. (P/A)	Pol. (H/V)	
802.11n HT40 CH 38 5190MHz		5146.9	57.31	-16.69	74	49.54	31.75	9.05	33.03	104	241	P	H	
		5149.5	50.8	-3.2	54	43.03	31.75	9.05	33.03	104	241	A	H	
	*	5190	107.03	-	-	99.19	31.78	9.09	33.03	104	241	P	H	
	*	5190	99.47	-	-	91.63	31.78	9.09	33.03	104	241	A	H	
		5360.04	49.53	-24.47	74	41.42	31.95	9.19	33.03	104	241	P	H	
		5424.44	41.3	-12.7	54	33.04	32.02	9.26	33.02	104	241	A	H	
		5146.38	53.96	-20.04	74	46.19	31.75	9.05	33.03	302	276	P	V	
		5149.76	47.74	-6.26	54	39.97	31.75	9.05	33.03	302	276	A	V	
	*	5190	104.22	-	-	96.38	31.78	9.09	33.03	302	276	P	V	
	*	5190	96.35	-	-	88.51	31.78	9.09	33.03	302	276	A	V	
		5421.36	50.08	-23.92	74	41.82	32.02	9.26	33.02	302	276	P	V	
		5439	40.68	-13.32	54	32.41	32.03	9.26	33.02	302	276	A	V	
	802.11n HT40 CH 46 5230MHz		5138.32	52.46	-21.54	74	44.71	31.73	9.05	33.03	100	246	P	H
			5150	46.64	-7.36	54	38.87	31.75	9.05	33.03	100	246	A	H
*		5230	111.66	-	-	103.75	31.83	9.11	33.03	100	246	P	H	
*		5230	103.89	-	-	95.98	31.83	9.11	33.03	100	246	A	H	
		5377.68	51.72	-22.28	74	43.56	31.98	9.2	33.02	100	246	P	H	
		5352.2	44.2	-9.8	54	36.09	31.95	9.19	33.03	100	246	A	H	
		5145.34	49.67	-24.33	74	41.9	31.75	9.05	33.03	335	278	P	V	
		5148.72	43.19	-10.81	54	35.42	31.75	9.05	33.03	335	278	A	V	
*		5230	108.39	-	-	100.48	31.83	9.11	33.03	335	278	P	V	
*		5230	100.57	-	-	92.66	31.83	9.11	33.03	335	278	A	V	
	5374.88	51.45	-22.55	74	43.3	31.97	9.2	33.02	335	278	P	V		
	5355	42.16	-11.84	54	34.05	31.95	9.19	33.03	335	278	A	V		
Remark	1. No other spurious found. 2. All results are PASS against Peak and Average limit line.													



Band 1 5150~5250MHz
WIFI 802.11n HT40 (Harmonic @ 3m)

WIFI Ant. 1+2	Note	Frequency (MHz)	Level (dBμV/m)	Over Limit (dB)	Limit Line (dBμV/m)	Read Level (dBμV)	Antenna Factor (dB/m)	Path Loss (dB)	Preamp Factor (dB)	Ant Pos (cm)	Table Pos (deg)	Peak Avg. (P/A)	Pol. (H/V)
802.11n HT40 CH 38 5190MHz		10380	45.01	-23.19	68.2	55.72	39.54	14.64	65.2	100	0	P	H
		15570	44.69	-29.31	74	52.47	37.91	17.98	64.05	100	0	P	H
		10380	46.14	-22.06	68.2	56.85	39.54	14.64	65.2	100	0	P	V
		15570	46.31	-27.69	74	54.09	37.91	17.98	64.05	100	0	P	V
802.11n HT40 CH 46 5230MHz		4486	53.53	-14.67	68.2	47.95	30.67	8.05	33.14	100	246	P	H
		4924	54.45	-19.55	74	47.04	31.48	8.99	33.06	100	246	P	H
		4924	47.2	-6.8	54	39.79	31.48	8.99	33.06	100	246	A	H
		4972	53.34	-20.66	74	45.87	31.57	8.95	33.05	100	246	P	H
		4972	47.09	-6.91	54	39.62	31.57	8.95	33.05	100	246	A	H
		10460	45.32	-22.88	68.2	55.89	39.63	14.69	65.2	100	0	P	H
		15690	43.33	-30.67	74	51.67	37.57	18.07	64.32	100	0	P	H
		4924	53.34	-20.66	74	45.93	31.48	8.99	33.06	335	278	P	V
		4924	45.39	-8.61	54	37.98	31.48	8.99	33.06	335	278	A	V
		10460	45.97	-22.23	68.2	56.54	39.63	14.69	65.2	100	0	P	V
	15690	45.25	-28.75	74	53.59	37.57	18.07	64.32	100	0	P	V	
Remark	1. No other spurious found. 2. All results are PASS against Peak and Average limit line.												



Band 1 5150~5250MHz
WIFI 802.11ac VHT80 (Band Edge @ 3m)

Table with 14 columns: WIFI Ant. 1+2, Note, Frequency (MHz), Level (dBµV/m), Over Limit (dB), Limit Line (dBµV/m), Read Level (dBµV), Antenna Factor (dB/m), Path Loss (dB), Preamp Factor (dB), Ant Pos (cm), Table Pos (deg), Peak Avg. (P/A), Pol. (H/V). Rows include test results for 802.11ac VHT80 CH 42 5210MHz and a Remark section.



Band 1 5150~5250MHz

WIFI 802.11ac VHT80 (Harmonic @ 3m)

WIFI Ant. 1+2	Note	Frequency (MHz)	Level (dBμV/m)	Over Limit (dB)	Limit Line (dBμV/m)	Read Level (dBμV)	Antenna Factor (dB/m)	Path Loss (dB)	Preamp Factor (dB)	Ant Pos (cm)	Table Pos (deg)	Peak Avg. (P/A)	Pol. (H/V)
802.11ac		10420	44.78	-29.22	74	55.42	39.58	14.67	65.2	100	0	P	H
VHT80		15630	44.68	-29.32	74	52.78	37.71	18.03	64.2	100	0	P	H
CH 42		10420	44.66	-29.34	74	55.3	39.58	14.67	65.2	100	0	P	V
5210MHz		15630	45.97	-28.03	74	54.07	37.71	18.03	64.2	100	0	P	V
Remark	1. No other spurious found. 2. All results are PASS against Peak and Average limit line.												



Band 2 - 5250~5350MHz

WIFI 802.11n HT20 (Band Edge @ 3m)

WIFI	Note	Frequency	Level	Over	Limit	Read	Antenna	Path	Preamp	Ant	Table	Peak	Pol.
Ant.				Limit	Line	Level	Factor	Loss	Factor	Pos	Pos	Avg.	
1+2		(MHz)	(dBμV/m)	(dB)	(dBμV/m)	(dBμV)	(dB/m)	(dB)	(dB)	(cm)	(deg)	(P/A)	(H/V)
802.11n HT20 CH 52 5260MHz		5020.4	52.71	-21.29	74	45.18	31.62	8.95	33.04	100	245	P	H
		5017.34	45.6	-8.4	54	38.07	31.62	8.95	33.04	100	245	A	H
	*	5260	114.59	-	-	106.63	31.87	9.12	33.03	100	245	P	H
	*	5260	107.2	-	-	99.24	31.87	9.12	33.03	100	245	A	H
		5365.68	53.06	-20.94	74	44.93	31.97	9.19	33.03	100	245	P	H
		5350.08	45.49	-8.51	54	37.38	31.95	9.19	33.03	100	245	A	H
		5018.7	50.49	-23.51	74	42.96	31.62	8.95	33.04	345	274	P	V
		5015.98	43.05	-10.95	54	35.52	31.62	8.95	33.04	345	274	A	V
	*	5260	110.33	-	-	102.37	31.87	9.12	33.03	345	274	P	V
	*	5260	102.81	-	-	94.85	31.87	9.12	33.03	345	274	A	V
		5363.52	50.16	-23.84	74	42.03	31.97	9.19	33.03	345	274	P	V
		5417.76	41.93	-12.07	54	33.71	32.02	9.22	33.02	345	274	A	V
802.11n HT20 CH 60 5300MHz		5059.5	51.86	-22.14	74	44.24	31.67	8.99	33.04	100	245	P	H
		5058.48	44.64	-9.36	54	37.02	31.67	8.99	33.04	100	245	A	H
	*	5300	114.37	-	-	106.34	31.9	9.16	33.03	100	245	P	H
	*	5300	106.99	-	-	98.96	31.9	9.16	33.03	100	245	A	H
		5350.8	56.7	-17.3	74	48.59	31.95	9.19	33.03	100	245	P	H
		5350.08	47.8	-6.2	54	39.69	31.95	9.19	33.03	100	245	A	H
		5053.38	49.22	-24.78	74	41.64	31.65	8.97	33.04	325	279	P	V
		5143.48	41.85	-12.15	54	34.08	31.75	9.05	33.03	325	279	A	V
	*	5300	110.58	-	-	102.55	31.9	9.16	33.03	325	279	P	V
	*	5300	103.11	-	-	95.08	31.9	9.16	33.03	325	279	A	V
		5350.08	52.7	-21.3	74	44.59	31.95	9.19	33.03	325	279	P	V
		5351.04	43.88	-10.12	54	35.77	31.95	9.19	33.03	325	279	A	V



802.11n HT20 CH 64 5320MHz	*	5320	111.02	-	-	102.96	31.92	9.17	33.03	110	243	P	H
	*	5320	103.78	-	-	95.72	31.92	9.17	33.03	110	243	A	H
		5351.68	54.31	-19.69	74	46.2	31.95	9.19	33.03	110	243	P	H
		5350.08	47.11	-6.89	54	39	31.95	9.19	33.03	110	243	A	H
	*	5320	107.48	-	-	99.42	31.92	9.17	33.03	304	281	P	V
	*	5320	100.1	-	-	92.04	31.92	9.17	33.03	304	281	A	V
		5354.24	53.09	-20.91	74	44.98	31.95	9.19	33.03	304	281	P	V
		5351.04	43.46	-10.54	54	35.35	31.95	9.19	33.03	304	281	A	V
Remark	<ol style="list-style-type: none"> No other spurious found. All results are PASS against Peak and Average limit line. 												



Band 2 5250~5350MHz
WIFI 802.11n HT20 (Harmonic @ 3m)

Table with 14 columns: WIFI Ant. 1+2, Note, Frequency (MHz), Level (dBµV/m), Over Limit (dB), Limit Line (dBµV/m), Read Level (dBµV), Antenna Factor (dB/m), Path Loss (dB), Preamp Factor (dB), Ant Pos (cm), Table Pos (deg), Peak Avg. (P/A), Pol. (H/V). Rows include data for 802.11n HT20 CH 52 at 5260MHz.



802.11n HT20 CH 60 5300MHz		4546	53.08	-20.92	74	47.35	30.79	8.07	33.13	100	245	P	H
		4546	48.57	-5.43	54	42.84	30.79	8.07	33.13	100	245	A	H
		4906	53.37	-20.63	74	46	31.44	8.99	33.06	100	245	P	H
		4906	46.48	-7.52	54	39.11	31.44	8.99	33.06	100	245	A	H
		4978	54.47	-19.53	74	47.02	31.57	8.93	33.05	100	245	P	H
		4978	47.56	-6.44	54	40.11	31.57	8.93	33.05	100	245	A	H
		10600	46.14	-27.86	74	56.43	39.78	14.8	65.18	100	0	P	H
		15900	42.98	-31.02	74	52.23	36.99	18.25	64.77	100	0	P	H
		10600	46.71	-27.29	74	57	39.78	14.8	65.18	100	0	P	V
		15900	47.28	-26.72	74	56.53	36.99	18.25	64.77	100	0	P	V



802.11n HT20 CH 64 5320MHz		4558	53.1	-20.9	74	47.36	30.79	8.07	33.12	110	243	P	H
		4558	50.71	-3.29	54	44.97	30.79	8.07	33.12	110	243	A	H
		4930	52.39	-21.61	74	45	31.48	8.97	33.06	110	243	P	H
		4930	43.86	-10.14	54	36.47	31.48	8.97	33.06	110	243	A	H
		4996	53.5	-20.5	74	46.01	31.6	8.93	33.04	110	243	P	H
		4996	45.22	-8.78	54	37.73	31.6	8.93	33.04	110	243	A	H
		10640	44.02	-29.98	74	54.26	39.81	14.82	65.17	100	0	P	H
		15960	45.11	-28.89	74	54.67	36.8	18.3	64.92	100	0	P	H
		10640	44.59	-29.41	74	54.83	39.81	14.82	65.17	100	0	P	V
		15960	46.9	-27.1	74	56.46	36.8	18.3	64.92	100	0	P	V

Remark

3. No other spurious found.
4. All results are PASS against Peak and Average limit line.



Band 2 5250~5350MHz

WIFI 802.11n HT40 (Band Edge @ 3m)

WIFI Ant. 1+2	Note	Frequency (MHz)	Level (dBμV/m)	Over Limit (dB)	Limit Line (dBμV/m)	Read Level (dBμV)	Antenna Factor (dB/m)	Path Loss (dB)	Preamp Factor (dB)	Ant Pos (cm)	Table Pos (deg)	Peak Avg. (P/A)	Pol. (H/V)
802.11n HT40 CH 54 5270MHz		5045.22	51.16	-22.84	74	43.58	31.65	8.97	33.04	105	243	P	H
		5032.64	44.6	-9.4	54	37.04	31.63	8.97	33.04	105	243	A	H
	*	5270	111.6	-	-	103.62	31.87	9.14	33.03	105	243	P	H
	*	5270	103.79	-	-	95.81	31.87	9.14	33.03	105	243	A	H
		5355.84	55.52	-18.48	74	47.41	31.95	9.19	33.03	105	243	P	H
		5351.28	46.62	-7.38	54	38.51	31.95	9.19	33.03	105	243	A	H
		5110.5	49.84	-24.16	74	42.13	31.72	9.03	33.04	329	278	P	V
		5033.66	42.45	-11.55	54	34.89	31.63	8.97	33.04	329	278	A	V
	*	5270	107.99	-	-	100.01	31.87	9.14	33.03	329	278	P	V
	*	5270	99.96	-	-	91.98	31.87	9.14	33.03	329	278	A	V
		5354.64	52.25	-21.75	74	44.14	31.95	9.19	33.03	329	278	P	V
		5355.12	42.85	-11.15	54	34.74	31.95	9.19	33.03	329	278	A	V
802.11n HT40 CH 62 5310MHz		5057.8	48.63	-25.37	74	41.01	31.67	8.99	33.04	102	245	P	H
		5000	42.34	-11.66	54	34.85	31.6	8.93	33.04	102	245	A	H
	*	5310	105.61	-	-	97.56	31.92	9.16	33.03	102	245	P	H
	*	5310	97.39	-	-	89.34	31.92	9.16	33.03	102	245	A	H
		5350.8	55.71	-18.29	74	47.6	31.95	9.19	33.03	102	245	P	H
		5350.08	49.4	-4.6	54	41.29	31.95	9.19	33.03	102	245	A	H
		5146.88	49.22	-24.78	74	41.45	31.75	9.05	33.03	325	278	P	V
		5056.78	41.23	-12.77	54	33.61	31.67	8.99	33.04	325	278	A	V
	*	5310	101.68	-	-	93.63	31.92	9.16	33.03	325	278	P	V
	*	5310	93.99	-	-	85.94	31.92	9.16	33.03	325	278	A	V
	5354.64	50.6	-23.4	74	42.49	31.95	9.19	33.03	325	278	P	V	
	5350.08	44.2	-9.8	54	36.09	31.95	9.19	33.03	325	278	A	V	
Remark	<p>1. No other spurious found.</p> <p>2. All results are PASS against Peak and Average limit line.</p>												



Band 2 5250~5350MHz
WIFI 802.11n HT40 (Harmonic @ 3m)

Table with 14 columns: WIFI Ant. 1+2, Note, Frequency (MHz), Level (dBµV/m), Over Limit (dB), Limit Line (dBµV/m), Read Level (dBµV), Antenna Factor (dB/m), Path Loss (dB), Preamp Factor (dB), Ant Pos (cm), Table Pos (deg), Peak Avg. (P/A), Pol. (H/V). Rows include data for 802.11n HT40 CH 54 (5270MHz) and 802.11n HT40 CH 62 (5310MHz).

Remark

- 1. No other spurious found.
2. All results are PASS against Peak and Average limit line.



Band 2 5250~5350MHz
WIFI 802.11ac VHT80 (Band Edge @ 3m)

Table with 14 columns: WIFI Ant. 1+2, Note, Frequency (MHz), Level (dBµV/m), Over Limit (dB), Limit Line (dBµV/m), Read Level (dBµV), Antenna Factor (dB/m), Path Loss (dB), Preamp Factor (dB), Ant Pos (cm), Table Pos (deg), Peak Avg. (P/A), Pol. (H/V). Rows include test results for 802.11ac VHT80 CH 58 5290MHz and a Remark section.



Band 2 5250~5350MHz

WIFI 802.11ac VHT80 (Harmonic @ 3m)

WIFI Ant. 1+2	Note	Frequency (MHz)	Level (dBμV/m)	Over Limit (dB)	Limit Line (dBμV/m)	Read Level (dBμV)	Antenna Factor (dB/m)	Path Loss (dB)	Preamp Factor (dB)	Ant Pos (cm)	Table Pos (deg)	Peak Avg. (P/A)	Pol. (H/V)
802.11ac		10580	45.19	-28.81	74	55.51	39.77	14.78	65.18	100	0	P	H
VHT80		15870	41.91	-32.09	74	51.09	37.04	18.22	64.73	100	0	P	H
CH 58		10580	45.13	-28.87	74	55.45	39.77	14.78	65.18	100	0	P	V
5290MHz		15870	41.99	-32.01	74	51.17	37.04	18.22	64.73	100	0	P	V
Remark	1. No other spurious found. 2. All results are PASS against Peak and Average limit line.												



Band 3 - 5470~5725MHz

WIFI 802.11n HT20 (Band Edge @ 3m)

WIFI	Note	Frequency	Level	Over	Limit	Read	Antenna	Path	Preamp	Ant	Table	Peak	Pol.
Ant.				Limit	Line	Level	Factor	Loss	Factor	Pos	Pos	Avg.	
1+2		(MHz)	(dBμV/m)	(dB)	(dBμV/m)	(dBμV)	(dB/m)	(dB)	(dB)	(cm)	(deg)	(P/A)	(H/V)
802.11n HT20 CH 100 5500MHz		5454.96	54.75	-19.25	74	46.43	32.05	9.29	33.02	100	243	P	H
		5465.04	59.19	-9.01	68.2	50.85	32.07	9.29	33.02	100	243	P	H
		5458.96	46.22	-7.78	54	37.9	32.05	9.29	33.02	100	243	A	H
	*	5500	112	-	-	103.55	32.1	9.37	33.02	100	243	P	H
	*	5500	104.53	-	-	96.08	32.1	9.37	33.02	100	243	A	H
		5459.92	54.3	-19.7	74	45.98	32.05	9.29	33.02	359	278	P	V
		5469.2	53.85	-14.35	68.2	45.51	32.07	9.29	33.02	359	278	P	V
		5458.96	43.34	-10.66	54	35.02	32.05	9.29	33.02	359	278	A	V
	*	5500	108.53	-	-	100.08	32.1	9.37	33.02	359	278	P	V
*	5500	101.12	-	-	92.67	32.1	9.37	33.02	359	278	A	V	
802.11n HT20 CH 116 5580MHz		5421.04	52.06	-21.94	74	43.8	32.02	9.26	33.02	100	136	P	H
		5460.64	51.09	-17.11	68.2	42.77	32.05	9.29	33.02	100	136	P	H
		5421.76	43.79	-10.21	54	35.53	32.02	9.26	33.02	100	136	A	H
	*	5580	113.08	-	-	104.45	32.22	9.48	33.07	100	136	P	H
	*	5580	105.66	-	-	97.03	32.22	9.48	33.07	100	136	A	H
		5736.965	51.75	-16.45	68.2	42.49	32.53	9.88	33.15	100	136	P	H
		5446.48	48.34	-25.66	74	40.02	32.05	9.29	33.02	302	313	P	V
		5469.76	49.16	-19.04	68.2	40.82	32.07	9.29	33.02	302	313	P	V
		5424.88	40.88	-13.12	54	32.62	32.02	9.26	33.02	302	313	A	V
	*	5580	108.38	-	-	99.75	32.22	9.48	33.07	302	313	P	V
	*	5580	101.06	-	-	92.43	32.22	9.48	33.07	302	313	A	V
	5739.17	50.89	-17.31	68.2	41.63	32.53	9.88	33.15	302	313	P	V	



802.11n	*	5700	108.69	-	-	99.62	32.44	9.75	33.12	100	138	P	H
	*	5700	101.22	-	-	92.15	32.44	9.75	33.12	100	138	A	H
HT20		5727.8	55.32	-12.88	68.2	46.14	32.5	9.81	33.13	100	138	P	H
CH 140	*	5700	103.06	-	-	93.99	32.44	9.75	33.12	337	317	P	V
5700MHz	*	5700	95.52	-	-	86.45	32.44	9.75	33.12	337	317	A	V
		5728.44	52.44	-15.76	68.2	43.26	32.5	9.81	33.13	337	317	P	V
Remark	1. No other spurious found. 2. All results are PASS against Peak and Average limit line.												



Band 3 - 5470~5725MHz
WIFI 802.11n HT20 (Harmonic @ 3m)

WIFI Ant. 1+2	Note	Frequency (MHz)	Level (dBμV/m)	Over Limit (dB)	Limit Line (dBμV/m)	Read Level (dBμV)	Antenna Factor (dB/m)	Path Loss (dB)	Preamp Factor (dB)	Ant Pos (cm)	Table Pos (deg)	Peak Avg. (P/A)	Pol. (H/V)
802.11n HT20		11000	46.01	-27.99	74	55.63	40.1	15.08	65.1	100	0	P	H
		16500	52.52	-15.68	68.2	60.08	38.5	18.74	65.1	100	0	P	H
5500MHz CH 100		11000	49.17	-24.83	74	58.79	40.1	15.08	65.1	100	0	P	V
		16500	52.15	-16.05	68.2	59.71	38.5	18.74	65.1	100	0	P	V
802.11n HT20 CH 116		11160	55.74	-18.26	74	65.38	40.07	15.2	65.2	100	242	P	H
		11160	44.12	-9.88	54	53.76	40.07	15.2	65.2	100	242	A	H
		16740	46.9	-21.3	68.2	53.43	39.08	18.93	64.86	100	0	P	H
		11160	57.08	-16.92	74	66.72	40.07	15.2	65.2	100	108	P	V
		11160	46.24	-7.76	54	55.88	40.07	15.2	65.2	100	108	A	V
5580MHz CH 140		16740	50.87	-17.33	68.2	57.4	39.08	18.93	64.86	100	0	P	V
		11400	46.94	-27.06	74	56.6	40.02	15.38	65.34	100	0	P	H
		17100	54.3	-13.9	68.2	59.17	40.06	19.18	64.46	100	0	P	H
5700MHz		11400	49.6	-24.4	74	59.26	40.02	15.38	65.34	100	0	P	V
		17100	55.73	-12.47	68.2	60.6	40.06	19.18	64.46	100	0	P	V
Remark	1. No other spurious found. 2. All results are PASS against Peak and Average limit line.												



Band 3 - 5470~5725MHz
WIFI 802.11n HT40 (Band Edge @ 3m)

WIFI Ant. 1+2	Note	Frequency (MHz)	Level (dBμV/m)	Over Limit (dB)	Limit Line (dBμV/m)	Read Level (dBμV)	Antenna Factor (dB/m)	Path Loss (dB)	Preamp Factor (dB)	Ant Pos (cm)	Table Pos (deg)	Peak Avg. (P/A)	Pol. (H/V)
802.11n HT40 CH 102 5510MHz		5426.08	51.17	-22.83	74	42.91	32.02	9.26	33.02	100	240	P	H
		5469.28	57.29	-10.91	68.2	48.95	32.07	9.29	33.02	100	240	P	H
		5459.68	44.35	-9.65	54	36.03	32.05	9.29	33.02	100	240	A	H
	*	5510	105.09	-	-	96.65	32.1	9.37	33.03	100	240	P	H
	*	5510	97.16	-	-	88.72	32.1	9.37	33.03	100	240	A	H
		5737.91	49.2	-19	68.2	39.94	32.53	9.88	33.15	100	240	P	H
		5449.36	49.6	-24.4	74	41.28	32.05	9.29	33.02	319	284	P	V
		5469.76	53.36	-14.84	68.2	45.02	32.07	9.29	33.02	319	284	P	V
		5458.72	41.84	-12.16	54	33.52	32.05	9.29	33.02	319	284	A	V
	*	5510	101.09	-	-	92.65	32.1	9.37	33.03	319	284	P	V
	*	5510	93.43	-	-	84.99	32.1	9.37	33.03	319	284	A	V
		5744.21	49	-19.2	68.2	39.74	32.53	9.88	33.15	319	284	P	V
802.11n HT40 CH 110 5550MHz		5457.52	53.1	-20.9	74	44.78	32.05	9.29	33.02	100	239	P	H
		5464.24	54.24	-13.96	68.2	45.9	32.07	9.29	33.02	100	239	P	H
		5459.92	46	-8	54	37.68	32.05	9.29	33.02	100	239	A	H
	*	5550	110.29	-	-	101.71	32.19	9.44	33.05	100	239	P	H
	*	5550	102.39	-	-	93.81	32.19	9.44	33.05	100	239	A	H
		5727.515	49.7	-18.5	68.2	40.52	32.5	9.81	33.13	100	239	P	H
		5453.2	52.07	-21.93	74	43.75	32.05	9.29	33.02	316	288	P	V
		5462.32	51.06	-17.14	68.2	42.74	32.05	9.29	33.02	316	288	P	V
		5459.68	43.83	-10.17	54	35.51	32.05	9.29	33.02	316	288	A	V
	*	5550	107.98	-	-	99.4	32.19	9.44	33.05	316	288	P	V
	*	5550	99.74	-	-	91.16	32.19	9.44	33.05	316	288	A	V
		5726.885	49.53	-18.67	68.2	40.35	32.5	9.81	33.13	316	288	P	V



802.11n HT40 CH 134 5670MHz		5432.95	51.44	-22.56	74	43.17	32.03	9.26	33.02	100	138	P	H
		5464.1	49.81	-18.39	68.2	41.47	32.07	9.29	33.02	100	138	P	H
		5426.65	43.93	-10.07	54	35.67	32.02	9.26	33.02	100	138	A	H
	*	5670	109	-	-	100.02	32.41	9.68	33.11	100	138	P	H
	*	5670	100.67	-	-	91.69	32.41	9.68	33.11	100	138	A	H
		5740.15	53.82	-14.38	68.2	44.56	32.53	9.88	33.15	100	138	P	H
		5388.15	48.04	-25.96	74	39.88	31.98	9.2	33.02	316	9	P	V
		5463.4	47.91	-20.29	68.2	39.57	32.07	9.29	33.02	316	9	P	V
		5437.85	40.44	-13.56	54	32.17	32.03	9.26	33.02	316	9	A	V
	*	5670	104.16	-	-	95.18	32.41	9.68	33.11	316	9	P	V
	*	5670	95.99	-	-	87.01	32.41	9.68	33.11	316	9	A	V
		5731.575	51.25	-16.95	68.2	42.02	32.5	9.88	33.15	316	9	P	V
Remark	1. No other spurious found. 2. All results are PASS against Peak and Average limit line.												



Band 3 - 5470~5725MHz
WIFI 802.11n HT40 (Harmonic @ 3m)

WIFI Ant. 1+2	Note	Frequency (MHz)	Level (dBμV/m)	Over Limit (dB)	Limit Line (dBμV/m)	Read Level (dBμV)	Antenna Factor (dB/m)	Path Loss (dB)	Preamp Factor (dB)	Ant Pos (cm)	Table Pos (deg)	Peak Avg. (P/A)	Pol. (H/V)
802.11n HT40 CH 102 5510MHz		11020	45.86	-28.14	74	55.47	40.1	15.11	65.11	100	0	P	H
		16530	46.71	-21.49	68.2	54.14	38.58	18.76	65.07	100	0	P	H
		11020	45.97	-28.03	74	55.58	40.1	15.11	65.11	100	0	P	V
		16530	45.45	-22.75	68.2	52.88	38.58	18.76	65.07	100	0	P	V
		16650	47.92	-20.28	68.2	54.82	38.87	18.86	64.94	100	0	P	H
		11100	48.08	-25.92	74	57.71	40.08	15.16	65.16	100	0	P	V
802.11n HT40 CH 134 5670MHz		11340	46.98	-27.02	74	56.63	40.03	15.33	65.3	100	0	P	H
		17010	50.5	-17.7	68.2	55.84	39.76	19.14	64.58	100	0	P	H
		11340	47.27	-26.73	74	56.92	40.03	15.33	65.3	100	0	P	V
		17010	50.09	-18.11	68.2	55.43	39.76	19.14	64.58	100	0	P	V
Remark	1. No other spurious found. 2. All results are PASS against Peak and Average limit line.												



Band 3 - 5470~5725MHz
WIFI 802.11ac VHT80 (Band Edge @ 3m)

WIFI Ant. 1+2	Note	Frequency (MHz)	Level (dBμV/m)	Over Limit (dB)	Limit Line (dBμV/m)	Read Level (dBμV)	Antenna Factor (dB/m)	Path Loss (dB)	Preamp Factor (dB)	Ant Pos (cm)	Table Pos (deg)	Peak Avg. (P/A)	Pol. (H/V)
802.11ac VHT80 CH 106 5530MHz		5445.04	53.82	-20.18	74	45.52	32.03	9.29	33.02	100	127	P	H
		5467.12	54.43	-13.77	68.2	46.09	32.07	9.29	33.02	100	127	P	H
		5459.2	46.52	-7.48	54	38.2	32.05	9.29	33.02	100	127	A	H
	*	5530	99.8	-	-	91.31	32.13	9.41	33.05	100	127	P	H
	*	5530	91.99	-	-	83.5	32.13	9.41	33.05	100	127	A	H
		5744.21	49.34	-18.86	68.2	40.08	32.53	9.88	33.15	100	127	P	H
		5454.88	52.16	-21.84	74	43.84	32.05	9.29	33.02	322	285	P	V
		5464	53.53	-14.67	68.2	45.19	32.07	9.29	33.02	322	285	P	V
		5459.68	44.78	-9.22	54	36.46	32.05	9.29	33.02	322	285	A	V
	*	5530	97.35	-	-	88.86	32.13	9.41	33.05	322	285	P	V
	*	5530	89.2	-	-	80.71	32.13	9.41	33.05	322	285	A	V
		5744.525	49.22	-18.98	68.2	39.96	32.53	9.88	33.15	322	285	P	V
802.11ac VHT80 CH 122 5610MHz		5459.9	55.1	-18.9	74	46.78	32.05	9.29	33.02	111	127	P	H
		5462	55.06	-13.14	68.2	46.74	32.05	9.29	33.02	111	127	P	H
		5458.15	46.85	-7.15	54	38.53	32.05	9.29	33.02	111	127	A	H
	*	5610	107.65	-	-	98.89	32.29	9.55	33.08	111	127	P	H
	*	5610	99.26	-	-	90.5	32.29	9.55	33.08	111	127	A	H
		5742.25	53.53	-14.67	68.2	44.27	32.53	9.88	33.15	111	127	P	H
		5454.65	50.57	-23.43	74	42.25	32.05	9.29	33.02	330	292	P	V
		5465.5	52.18	-16.02	68.2	43.84	32.07	9.29	33.02	330	292	P	V
		5458.15	44.57	-9.43	54	36.25	32.05	9.29	33.02	330	292	A	V
	*	5610	104.53	-	-	95.77	32.29	9.55	33.08	330	292	P	V
	*	5610	96.79	-	-	88.03	32.29	9.55	33.08	330	292	A	V
		5731.05	51.89	-16.31	68.2	42.66	32.5	9.88	33.15	330	292	P	V
Remark	1. No other spurious found. 2. All results are PASS against Peak and Average limit line.												



Band 3 5470~5725MHz

WIFI 802.11ac VHT80 (Harmonic @ 3m)

WIFI Ant. 1+2	Note	Frequency (MHz)	Level (dBμV/m)	Over Limit (dB)	Limit Line (dBμV/m)	Read Level (dBμV)	Antenna Factor (dB/m)	Path Loss (dB)	Preamp Factor (dB)	Ant Pos (cm)	Table Pos (deg)	Peak Avg. (P/A)	Pol. (H/V)
802.11ac		11060	46.22	-27.78	74	55.85	40.09	15.13	65.14	100	0	P	H
VHT80		16590	44.75	-23.45	68.2	51.94	38.71	18.81	65.01	100	0	P	H
CH 106		11060	46.23	-27.77	74	55.86	40.09	15.13	65.14	100	0	P	V
5530MHz		16590	45.37	-22.83	68.2	52.56	38.71	18.81	65.01	100	0	P	V
802.11ac		11220	47.57	-26.43	74	57.2	40.06	15.25	65.23	100	0	P	H
VHT80		16830	46.91	-21.29	68.2	53.06	39.29	19	64.77	100	0	P	H
CH 122		11220	49.66	-24.34	74	59.29	40.06	15.25	65.23	100	0	P	V
5610MHz		16830	46.46	-21.74	68.2	52.61	39.29	19	64.77	100	0	P	V
Remark	1. No other spurious found. 2. All results are PASS against Peak and Average limit line.												



Band 3 - Straddle Channel

WIFI 802.11n HT20 (Band Edge @ 3m)

WIFI	Note	Frequency	Level	Over	Limit	Read	Antenna	Path	Preamp	Ant	Table	Peak	Pol.
Ant.				Limit	Line	Level	Factor	Loss	Factor	Pos	Pos	Avg.	
1+2		(MHz)	(dBμV/m)	(dB)	(dBμV/m)	(dBμV)	(dB/m)	(dB)	(dB)	(cm)	(deg)	(P/A)	(H/V)
802.11n	*	5720	113.23	-	-	104.05	32.5	9.81	33.13	106	129	P	H
HT20	*	5720	105.76	-	-	96.58	32.5	9.81	33.13	106	129	A	H
CH 144	*	5720	108.81	-	-	99.63	32.5	9.81	33.13	314	296	P	V
5720MHz	*	5720	101.28	-	-	92.1	32.5	9.81	33.13	314	296	A	V
Remark	1. No other spurious found. 2. All results are PASS against Peak and Average limit line.												



Band 3 - Straddle Channel
WIFI 802.11n HT20 (Harmonic @ 3m)

WIFI Ant. 1+2	Note	Frequency (MHz)	Level (dBμV/m)	Over Limit (dB)	Limit Line (dBμV/m)	Read Level (dBμV)	Antenna Factor (dB/m)	Path Loss (dB)	Preamp Factor (dB)	Ant Pos (cm)	Table Pos (deg)	Peak Avg. (P/A)	Pol. (H/V)
802.11n HT20 CH 144 5720MHz		5404	53.33	-20.67	74	45.13	32	9.22	33.02	106	129	P	H
		5404	45.66	-8.34	54	37.46	32	9.22	33.02	106	129	A	H
		5566	56.78	-11.42	68.2	48.18	32.22	9.44	33.06	106	129	P	H
		5956	54.56	-13.64	68.2	44.84	32.94	10.02	33.24	106	129	P	H
		6040	55.32	-12.88	68.2	45.44	33.1	10.06	33.28	106	129	P	H
		11440	49.94	-24.06	74	59.61	40.01	15.4	65.36	100	0	P	H
		17160	52.19	-16.01	68.2	56.7	40.3	19.21	64.37	100	0	P	H
		4906	52.84	-21.16	74	45.47	31.44	8.99	33.06	314	296	P	V
		4906	49.63	-4.37	54	42.26	31.44	8.99	33.06	314	296	A	V
		11440	49.56	-24.44	74	59.23	40.01	15.4	65.36	100	0	P	V
		17160	55.04	-13.16	68.2	59.55	40.3	19.21	64.37	100	0	P	V
Remark	<ol style="list-style-type: none"> No other spurious found. All results are PASS against Peak and Average limit line. 												



Band 3 - Straddle Channel
WIFI 802.11n HT40 (Band Edge @ 3m)

Table with 14 columns: WIFI Ant. 1+2, Note, Frequency (MHz), Level (dBµV/m), Over Limit (dB), Limit Line (dBµV/m), Read Level (dBµV), Antenna Factor (dB/m), Path Loss (dB), Preamp Factor (dB), Ant Pos (cm), Table Pos (deg), Peak Avg. (P/A), Pol. (H/V). Rows include 802.11n, HT40, CH 142, 5710MHz and a Remark section.



Band 3 - Straddle Channel
WIFI 802.11n HT40 (Harmonic @ 3m)

Table with 14 columns: WIFI Ant. 1+2, Note, Frequency (MHz), Level (dBµV/m), Over Limit (dB), Limit Line (dBµV/m), Read Level (dBµV), Antenna Factor (dB/m), Path Loss (dB), Preamp Factor (dB), Ant Pos (cm), Table Pos (deg), Peak Avg. (P/A), Pol. (H/V). Rows include 802.11n HT40 CH 142 5710MHz and a Remark section.



Band 3 - Straddle Channel
WIFI 802.11ac VHT80 (Band Edge @ 3m)

Table with 14 columns: WIFI Ant. 1+2, Note, Frequency (MHz), Level (dBµV/m), Over Limit (dB), Limit Line (dBµV/m), Read Level (dBµV), Antenna Factor (dB/m), Path Loss (dB), Preamp Factor (dB), Ant Pos (cm), Table Pos (deg), Peak Avg. (P/A), Pol. (H/V). Rows include 802.11ac, VHT80, CH 138, 5690MHz and a Remark section.



Band 3 - Straddle Channel
WIFI 802.11ac VHT80 (Harmonic @ 3m)

Table with 14 columns: WIFI Ant. 1+2, Note, Frequency (MHz), Level (dBµV/m), Over Limit (dB), Limit Line (dBµV/m), Read Level (dBµV), Antenna Factor (dB/m), Path Loss (dB), Preamp Factor (dB), Ant Pos (cm), Table Pos (deg), Peak Avg. (P/A), Pol. (H/V). Rows include 802.11ac VHT80 CH 138 5690MHz and a Remark section.



Emission below 1GHz
WIFI 802.11ac VHT80 (LF @ 3m)

Table with 14 columns: WIFI, Note, Frequency, Level, Over, Limit, Read, Antenna, Path, Preamp, Ant, Table, Peak, Pol. It contains 12 rows of test data for 802.11n HT20 LF and a Remark section at the bottom.



Note symbol

*	Fundamental Frequency which can be ignored. However, the level of any unwanted emissions shall not exceed the level of the fundamental frequency.
!	Test result is over limit line.
P/A	Peak or Average
H/V	Horizontal or Vertical



A calculation example for radiated spurious emission is shown as below:

WIFI	Note	Frequency	Level	Over	Limit	Read	Antenna	Path	Preamp	Ant	Table	Peak	Pol.
Ant.				Limit	Line	Level	Factor	Loss	Factor	Pos	Pos	Avg.	
1		(MHz)	(dBμV/m)	(dB)	(dBμV/m)	(dBμV)	(dB/m)	(dB)	(dB)	(cm)	(deg)	(P/A)	(H/V)
802.11b		2390	55.45	-18.55	74	54.51	32.22	4.58	35.86	103	308	P	H
CH 01													
2412MHz		2390	43.54	-10.46	54	42.6	32.22	4.58	35.86	103	308	A	H

1. Path Loss(dB) = Cable loss(dB) + Filter loss(dB) + Attenuator loss(dB)
2. Level(dBμV/m) = Antenna Factor(dB/m) + Path Loss(dB) + Read Level(dBμV) - Preamp Factor(dB)
3. Over Limit(dB) = Level(dBμV/m) – Limit Line(dBμV/m)

For Peak Limit @ 2390MHz:

1. Level(dBμV/m)
= Antenna Factor(dB/m) + Path Loss(dB) + Read Level(dBμV) - Preamp Factor(dB)
= 32.22(dB/m) + 4.58(dB) + 54.51(dBμV) – 35.86 (dB)
= 55.45 (dBμV/m)
2. Over Limit(dB)
= Level(dBμV/m) – Limit Line(dBμV/m)
= 55.45(dBμV/m) – 74(dBμV/m)
= -18.55(dB)

For Average Limit @ 2390MHz:

1. Level(dBμV/m)
= Antenna Factor(dB/m) + Path Loss(dB) + Read Level(dBμV) - Preamp Factor(dB)
= 32.22(dB/m) + 4.58(dB) + 42.6(dBμV) – 35.86 (dB)
= 43.54 (dBμV/m)
2. Over Limit(dB) = Level(dBμV/m) – Limit Line(dBμV/m)
= 43.54(dBμV/m) – 54(dBμV/m)
= -10.46(dB)

Both peak and average measured complies with the limit line, so test result is “PASS”.



Appendix C. Duty Cycle Plots

Antenna	Band	Duty Cycle(%)	T(ms)	1/T(kHz)	VBW Setting
1	802.11a	94.65	2.051	0.488	1kHz
1+2	802.11n HT20	84.75	0.983	1.018	3kHz
1+2	802.11n HT40	83.37	0.494	2.023	3kHz
1+2	802.11ac VHT80	89.89	0.464	2.156	3kHz



802.11a Ant.1

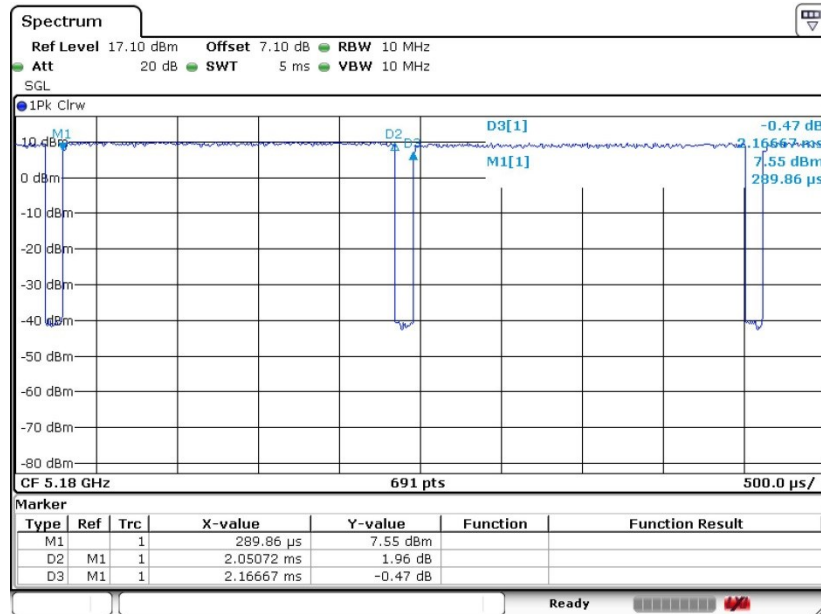

802.11n HT20 Ant. 1+2

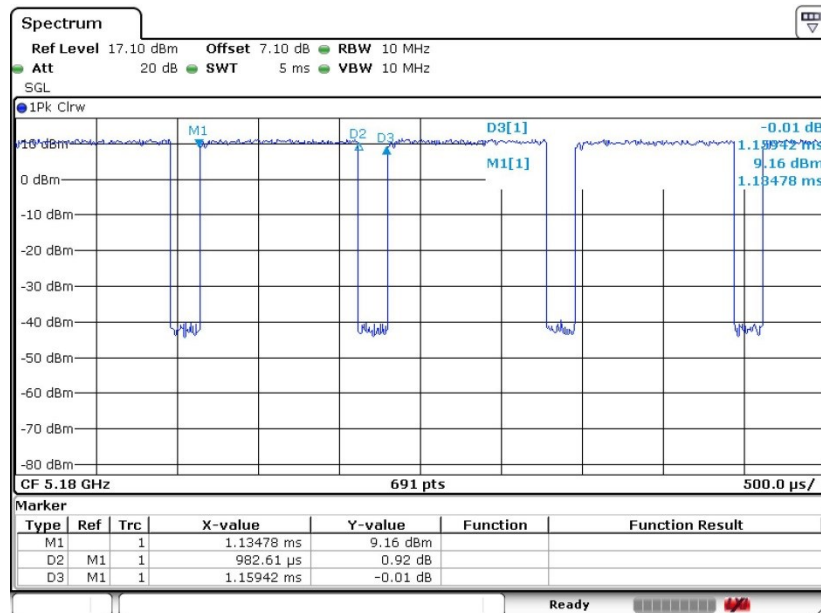



802.11n HT40 Ant. 1+2

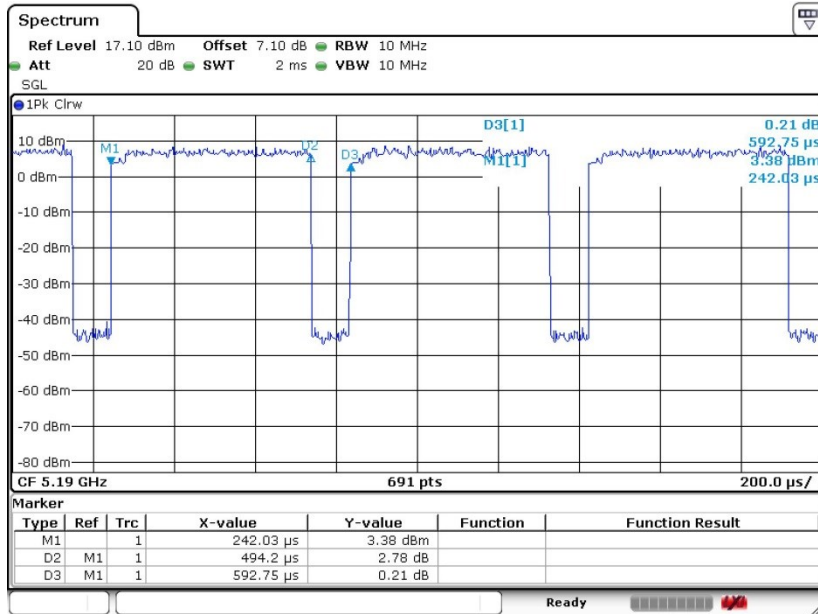

802.11ac VHT80 Ant. 1+2

