



中国认可  
国际互认  
检测  
TESTING  
CNAS L2264

## RF TEST REPORT

**Applicant**      Lenovo (Shanghai) Electronics  
   Technology Co., Ltd

**FCC ID**            O57TBX704V

**Product**          Portable Tablet Computer

**Brand**             Lenovo

**Model**            TB-X704V

**Report No.**       RXA1704-0095RF01R1

**Issue Date**      June 21, 2017

TA Technology (Shanghai) Co., Ltd. tested the above equipment in accordance with the requirements in **FCC CFR47 Part 15E (2016)**. The test results show that the equipment tested is capable of demonstrating compliance with the requirements as documented in this report.

*Xianqing Li*

Performed by: Xianqing Li

*Kai Xu*

Approved by: Kai Xu

---

**TA Technology (Shanghai) Co., Ltd.**

No.145, Jintang Rd, Tangzhen Industry Park, Pudong Shanghai, China

TEL: +86-021-50791141/2/3

FAX: +86-021-50791141/2/3-8000



## TABLE OF CONTENT

1. Test Laboratory .....	4
1.1. Notes of the test report.....	4
1.2. Test facility .....	4
1.3. Testing Location.....	5
2. General Description of Equipment under Test.....	6
3. Test Information .....	8
4. Test Configuration .....	9
5. Test Case Results .....	10
5.1. Occupied Bandwidth .....	10
5.2. Average Power Output –Conducted.....	25
5.3. Frequency Stability.....	29
5.4. Power Spectral Density .....	33
5.5. Unwanted Emission .....	49
5.6. Conducted Emission .....	393
6. Main Test Instruments.....	423
ANNEX A: EUT Appearance and Test Setup .....	424
A.1 EUT Appearance .....	424
A.2 Test Setup .....	426



## Summary of measurement results

Number	Summary of measurements of results	Clause in FCC rules	Verdict
1	Average conducted output power	15.407(a)	PASS
2	Occupied bandwidth	15.407(e)	PASS
3	Frequency stability	15.407(g)	PASS
4	Maximum power spectral density	15.407(a)	PASS
5	Unwanted Emissions	15.407(b)	PASS
6	Conducted Emissions	15.207	PASS
Date of Testing: April 12, 2017 ~ April 21, 2017			



## 1. Test Laboratory

### 1.1. Notes of the test report

This report shall not be reproduced in full or partial, without the written approval of **TA technology (shanghai) co., Ltd.** The results documented in this report apply only to the tested sample, under the conditions and modes of operation as described herein. Measurement Uncertainties were not taken into account and are published for informational purposes only. This report is written to support regulatory compliance of the applicable standards stated above. This report must not be used by the client to claim product certification, approval, or endorsement by any government agencies.

### 1.2. Test facility

#### **CNAS (accreditation number: L2264)**

TA Technology (Shanghai) Co., Ltd. has obtained the accreditation of China National Accreditation Service for Conformity Assessment (CNAS).

#### **FCC (recognition number is 428261)**

TA Technology (Shanghai) Co., Ltd. has been listed on the US Federal Communications Commission list of test facilities recognized to perform electromagnetic emissions measurements.

#### **IC (recognition number is 8510A)**

TA Technology (Shanghai) Co., Ltd. has been listed by industry Canada to perform electromagnetic emission measurement.

#### **VCCI (recognition number is C-4595, T-2154, R-4113, G-10766)**

TA Technology (Shanghai) Co., Ltd. has been listed by industry Japan to perform electromagnetic emission measurement.

#### **A2LA (Certificate Number: 3857.01)**

TA Technology (Shanghai) Co., Ltd. has been listed by American Association for Laboratory Accreditation to perform electromagnetic emission measurement.



### 1.3. Testing Location

Company: TA Technology (Shanghai) Co., Ltd.  
Address: No.145, Jintang Rd, Tangzhen Industry Park, Pudong  
City: Shanghai  
Post code: 201201  
Country: P. R. China  
Contact: Xu Kai  
Telephone: +86-021-50791141/2/3  
Fax: +86-021-50791141/2/3-8000  
Website: <http://www.ta-shanghai.com>  
E-mail: [xukai@ta-shanghai.com](mailto:xukai@ta-shanghai.com)

## 2. General Description of Equipment under Test

### Client Information

<b>Applicant</b>	Lenovo (Shanghai) Electronics Technology Co., Ltd
<b>Applicant address</b>	NO.68 BUILDING, 199 FENJU RD, Pilot Free Trade Zone, Shanghai, 200131, China
<b>Manufacturer</b>	Lenovo PC HK Limited
<b>Manufacturer address</b>	23/F, Lincoln House, Taikoo Place 979 King's Road, Quarry Bay, Hong Kong

### General information

EUT Description	
Model:	TB-X704V
IMEI:	863923030005663
Hardware Version:	Lenovo Tablet TB-X704V
Software Version:	TB-X704V_RF01_20170301
Power Supply:	Battery/ AC adapter
Antenna Type:	Internal Antenna
additional beamforming gain:	0 dB
Test Mode:	U-NII-1(5150MHz-5250MHz) U-NII-2A(5250MHz-5350MHz) U-NII-2C(5470MHz-5725MHz) U-NII-3(5725MHz-5850MHz)
Modulation Type:	802.11a/n (HT20/HT40) : OFDM 802.11ac (HT20.HT40/HT80): OFDM
Max. Conducted Power	802.11a: 13.56 dBm 802.11n: 13.47 dBm 802.11ac: 12.15 dBm
Operating Frequency Range(s)	U-NII-1: 5150-5250MHz U-NII-2A:5250-5350MHz U-NII-2C:5470-5725MHz(without 5600MHz -5650MHz) U-NII-3: 5725-5850MHz
EUT Accessory	
Battery	Manufacturer: Lenovo Mobile Communication Technology Ltd. Model: L16D2P31
Adapter 1	Manufacturer: Acbel Model: C-P35



Adapter 2

Manufacturer: Shenzhen Huntkey Electric Co., Ltd.  
Model: C-P35

Note: The information of the EUT is declared by the manufacturer.  
Please refer to the specifications or user manual for details.



### 3. Test Information

According to the specifications of the manufacturer, it must comply with the requirements of the following standards:

**FCC CFR47 Part 15E (2016)** Unlicensed National Information Infrastructure Devices

**ANSI C63.10 (2013)**

**789033 D02 General UNII Test Procedures New Rules v01r04**

**KDB 662911 D01 Multiple Transmitter Output v02r01**



## 4. Test Configuration

### Test Mode

The EUT was programmed to be in continuously transmitting mode and the transmit duty cycle is not less than 98%.

The EUT has been associated with peripherals and configuration operated in a manner tended to maximize its emission characteristics in a typical application.

The radiated emission was measured in the following position: EUT stand-up position (Z axis), lie-down position (X, Y axis). The worst emission was found in stand-up position (Z axis) and the worst case was recorded.

In order to find the worst case condition, Pre-tests are needed at the presence of different data rate. Preliminary tests have been done on all the configuration for confirming worst case. Data rate below means worst-case rate of each test item.

Worst-case data rates are shown as following table.

Band	Data Rate
802.11a	6 Mbps
802.11n HT20	MCS0
802.11n HT40	MCS0
802.11ac HT20	MCS0
802.11ac HT40	MCS0
802.11ac HT80	MCS0

The device supports non-beamforming and beamforming function in 802.11n/ac, after pre-testing, beamforming mode has the worst emission value, so the worst case was recorded.

## 5. Test Case Results

### 5.1. Occupied Bandwidth

#### Ambient condition

Temperature	Relative humidity	Pressure
23°C ~25°C	45%~50%	101.5kPa

#### Method of Measurement

The EUT was connected to the spectrum analyzer through an external attenuator (20dB) and a known loss cable.

For U-NII-1, set RBW  $\approx$ 1% OCB kHz, VBW  $\geq$  3  $\times$  RBW, measure the maximum width of the emission that is constrained by the frequencies associated with the two outermost amplitude points (upper and lower frequencies) that are attenuated by 26 dB relative to the maximum level measured in the fundamental emission.

For U-NII-3, Set RBW = 100 kHz, VBW  $\geq$  3  $\times$  RBW, measure the maximum width of the emission that is constrained by the frequencies associated with the two outermost amplitude points (upper and lower frequencies) that are attenuated by 6 dB relative to the maximum level measured in the fundamental emission.

Note: The automatic bandwidth measurement capability of a spectrum analyzer or EMI receiver may be employed if it implements the functionality described above.

Use the 99 % power bandwidth function of the instrument

#### Test Setup

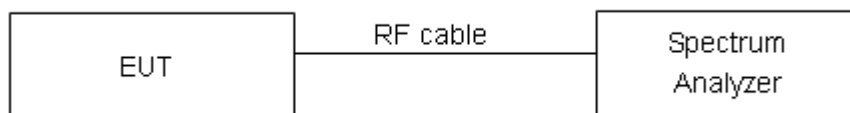

#### Limits

Rule FCC Part 15.407(a)(5)/15.407(e)

Within the 5.725-5.85 GHz band, the minimum 6 dB bandwidth of U-NII devices shall be at least 500 kHz.

#### Measurement Uncertainty

The assessed measurement uncertainty to ensure 95% confidence level for the normal distribution is with the coverage factor  $k = 2$ ,  $U = 936$  Hz.

**Test Results:****U-NII-1**

Network Standards	Carrier frequency (MHz)	99% bandwidth (MHz)	Minimum 26 dB bandwidth (MHz)	Limit (kHz)	Conclusion
802.11a	5180	16.703	21.60	500	PASS
	5200	16.739	21.68	500	PASS
	5240	16.735	21.43	500	PASS
802.11n HT20	5180	17.837	22.15	500	PASS
	5200	17.851	21.75	500	PASS
	5240	17.851	21.52	500	PASS
802.11n HT40	5190	36.027	40.29	500	PASS
	5230	36.098	39.56	500	PASS
802.11ac HT20	5180	17.847	21.75	500	PASS
	5200	17.842	21.63	500	PASS
	5240	17.847	21.60	500	PASS
802.11ac HT40	5190	35.998	39.51	500	PASS
	5230	35.775	38.98	500	PASS
802.11ac HT80	5210	74.509	78.53	500	PASS

**U-NII-2A**

Network Standards	Carrier frequency (MHz)	99% bandwidth (MHz)	Minimum 26 dB bandwidth (MHz)	Limit (kHz)	Conclusion
802.11a	5260	16.713	21.42	500	PASS
	5300	16.730	21.87	500	PASS
	5320	16.730	21.52	500	PASS
802.11n HT20	5260	17.783	21.87	500	PASS
	5300	17.791	21.84	500	PASS
	5320	17.839	21.97	500	PASS
802.11n HT40	5270	36.086	39.47	500	PASS
	5310	36.065	40.53	500	PASS
802.11ac HT20	5260	17.840	21.46	500	PASS
	5300	17.854	21.67	500	PASS
	5320	17.841	21.91	500	PASS
802.11ac HT40	5270	35.876	39.36	500	PASS
	5310	36.020	39.59	500	PASS
802.11ac HT80	5290	74.840	78.66	500	PASS

**U-NII-2C**

Network Standards	Carrier frequency (MHz)	99% bandwidth (MHz)	Minimum 26 dB bandwidth (MHz)	Limit (kHz)	Conclusion
802.11a	5500	16.804	21.90	500	PASS
	5580	16.753	21.92	500	PASS
	5700	16.760	21.82	500	PASS
802.11n HT20	5500	17.822	21.54	500	PASS
	5580	17.827	21.63	500	PASS
	5700	17.816	21.91	500	PASS
802.11n HT40	5510	35.986	39.19	500	PASS
	5670	35.975	40.31	500	PASS
802.11ac HT20	5500	17.830	21.73	500	PASS
	5580	17.835	21.72	500	PASS
	5700	17.874	21.79	500	PASS
802.11ac HT40	5510	35.800	39.66	500	PASS
	5670	35.967	39.19	500	PASS
802.11ac HT80	5530	74.530	79.06	500	PASS

**U-NII-3**

Network Standards	Carrier frequency (MHz)	99% bandwidth (MHz)	Minimum 6 dB bandwidth (MHz)	Limit (kHz)	Conclusion
802.11a	5745	16.518	16.43	500	PASS
	5785	16.538	16.43	500	PASS
	5825	16.529	16.38	500	PASS
802.11n HT20	5745	17.692	17.62	500	PASS
	5785	17.693	17.63	500	PASS
	5825	17.690	17.63	500	PASS
802.11n HT40	5755	35.865	35.24	500	PASS
	5795	35.908	35.24	500	PASS
802.11ac HT20	5745	17.692	17.62	500	PASS
	5785	17.703	17.63	500	PASS
	5825	17.695	17.66	500	PASS
802.11ac HT40	5755	35.867	35.31	500	PASS
	5795	35.950	35.16	500	PASS
802.11ac HT80	5775	74.811	73.90	500	PASS

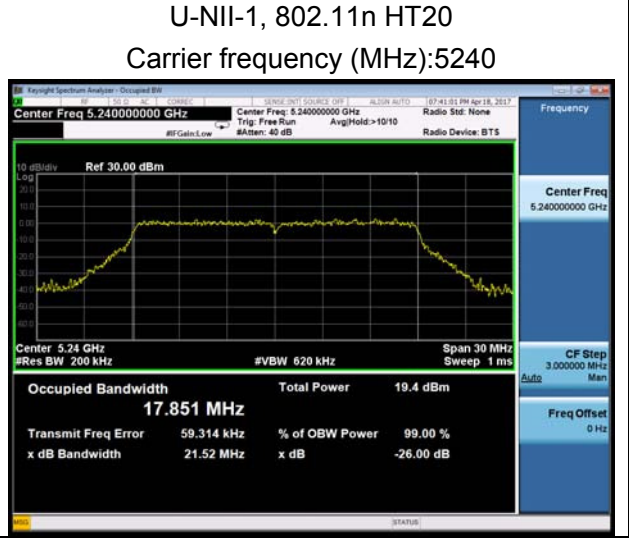
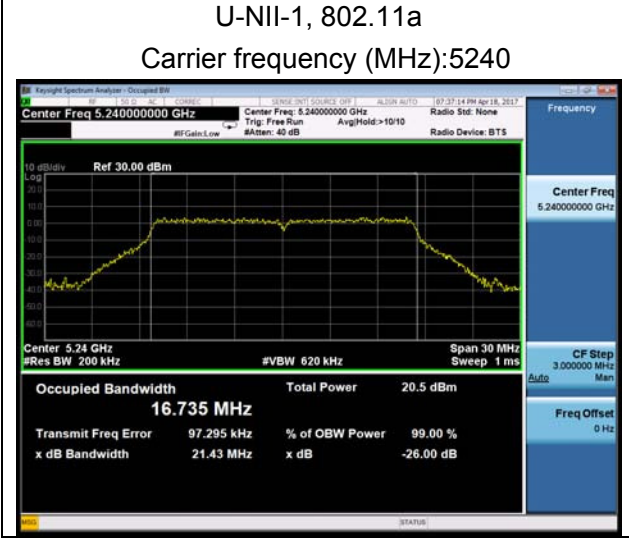
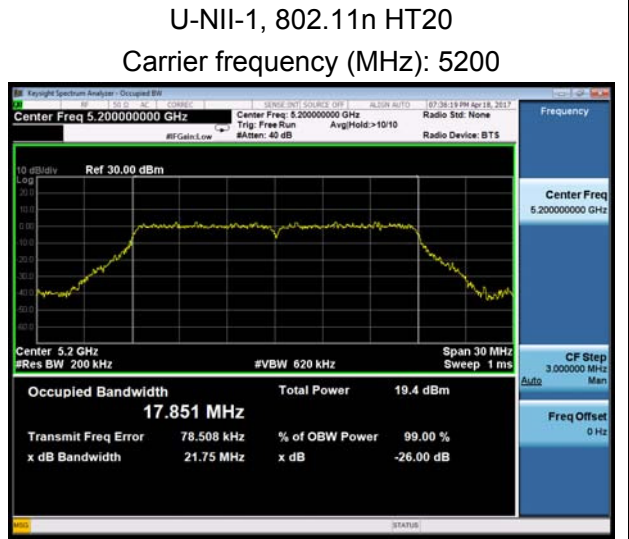
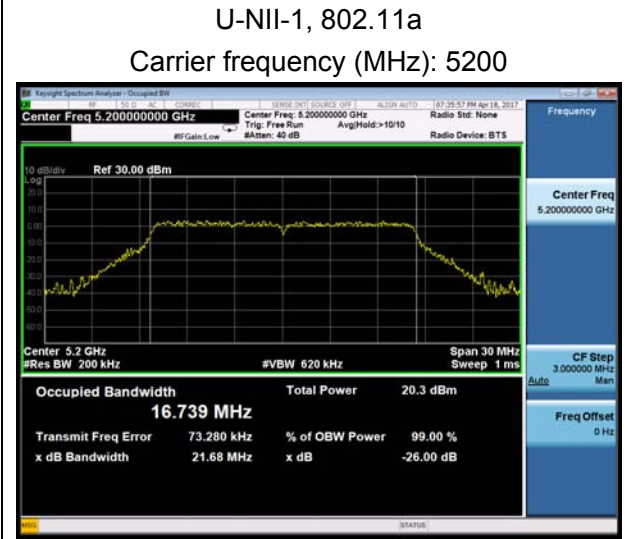
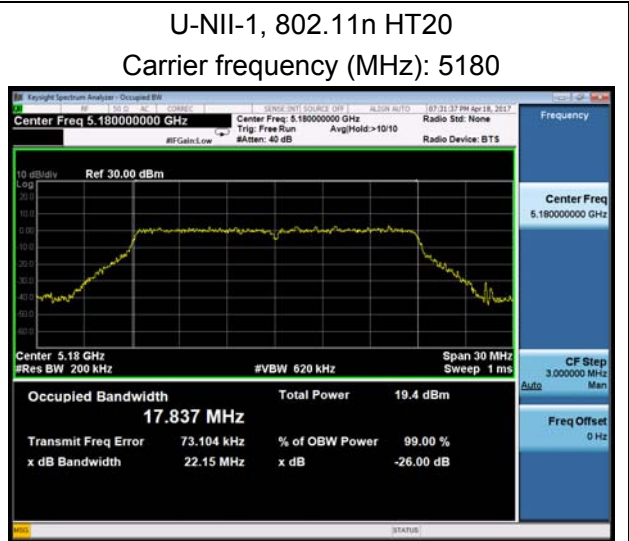
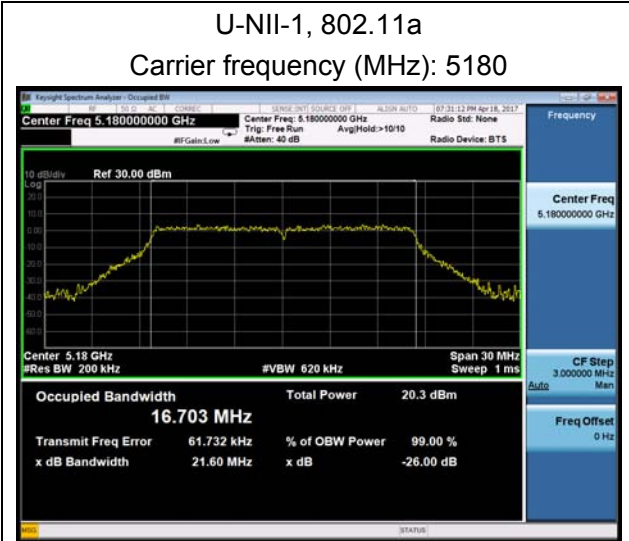

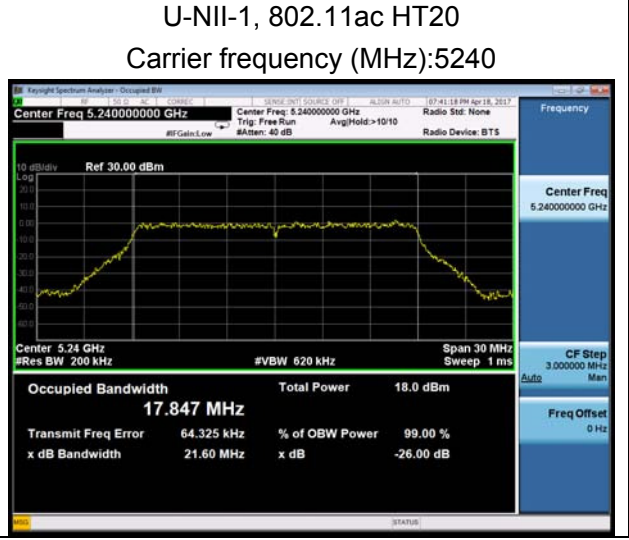
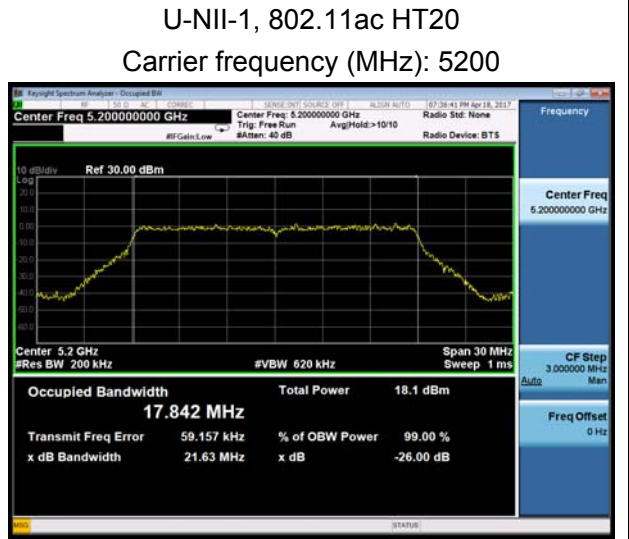
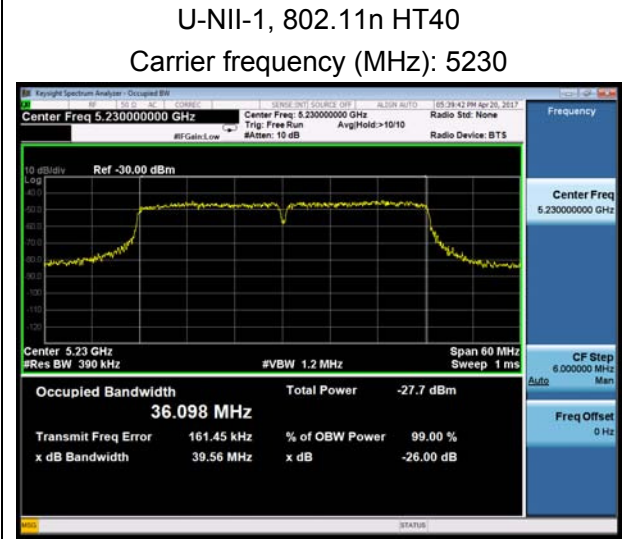
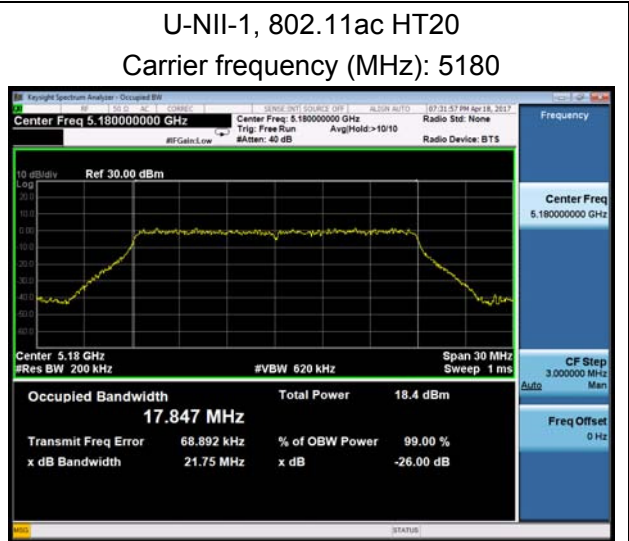
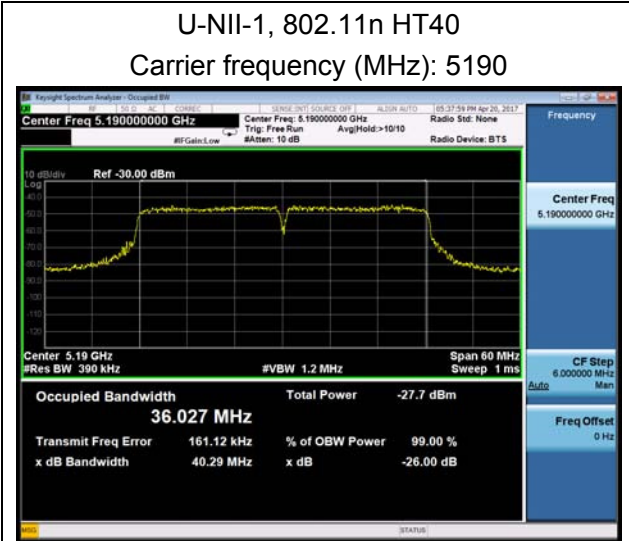



U-NII-1, 802.11ac HT40  
Carrier frequency (MHz): 5190



U-NII-1, 802.11ac HT80  
Carrier frequency (MHz): 5210



U-NII-1, 802.11ac HT40  
Carrier frequency (MHz): 5230



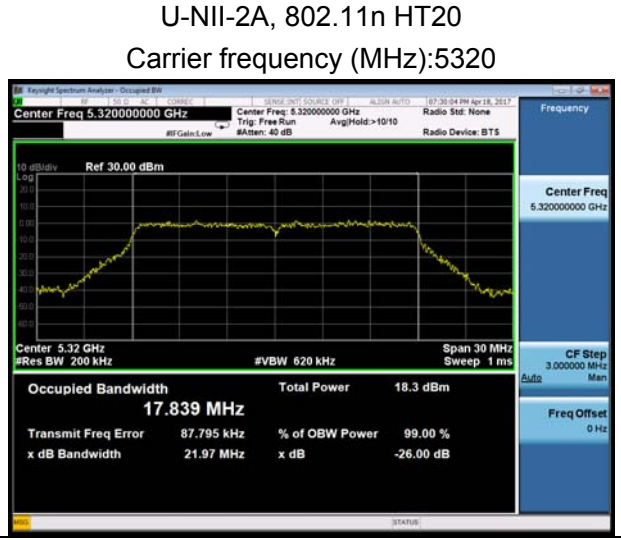
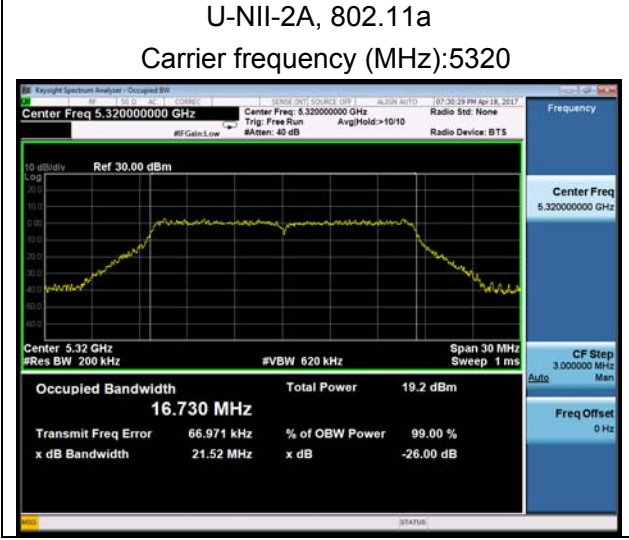
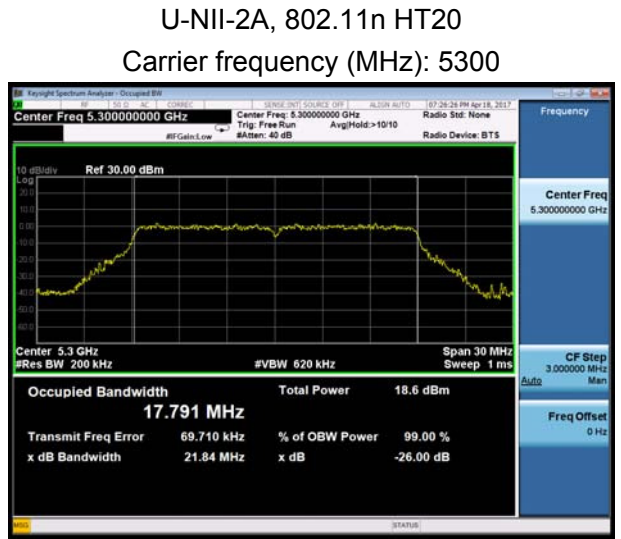
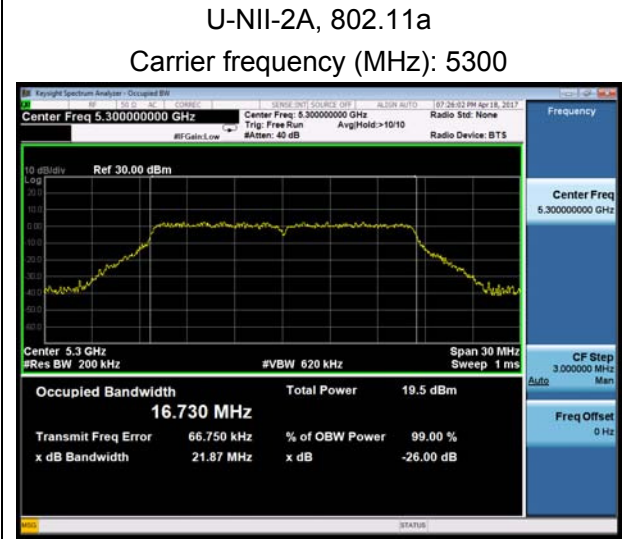
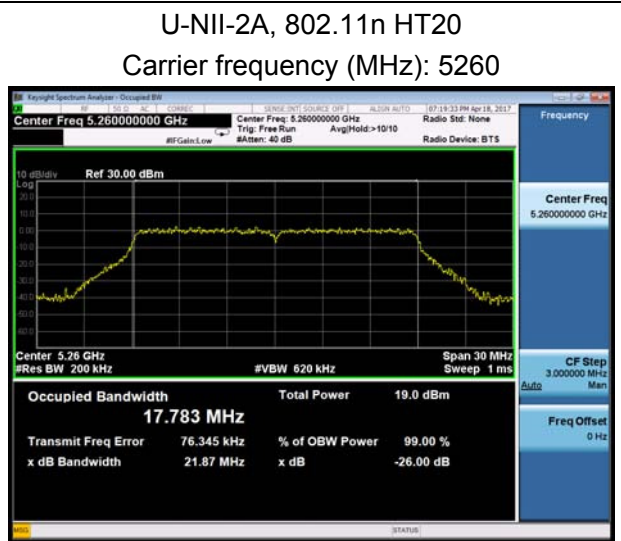
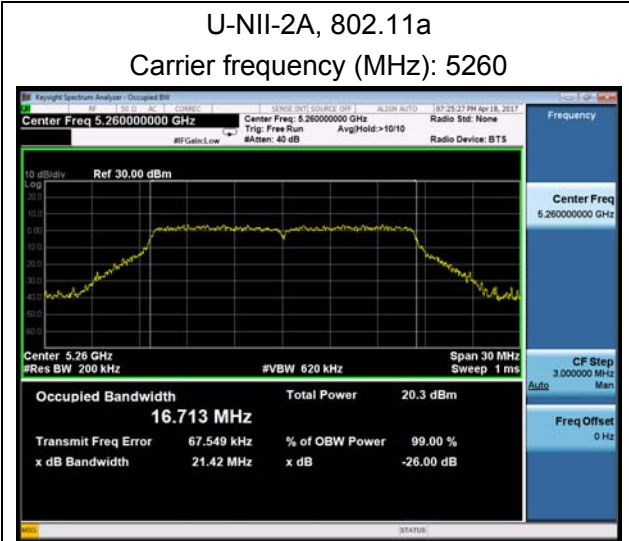



U-NII-2A, 802.11n HT40  
Carrier frequency (MHz): 5270



U-NII-2A, 802.11ac HT20  
Carrier frequency (MHz): 5260



U-NII-2A, 802.11n HT40  
Carrier frequency (MHz): 5310



U-NII-2A, 802.11ac HT20  
Carrier frequency (MHz): 5300



U-NII-2A, 802.11ac HT20  
Carrier frequency (MHz): 5320

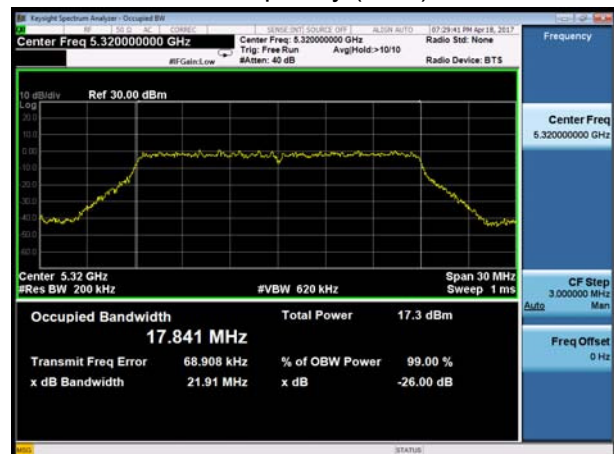



U-NII-2A, 802.11ac HT40  
Carrier frequency (MHz): 5270



U-NII-2A, 802.11ac HT80  
Carrier frequency (MHz): 5290



U-NII-2A, 802.11ac HT40  
Carrier frequency (MHz): 5310



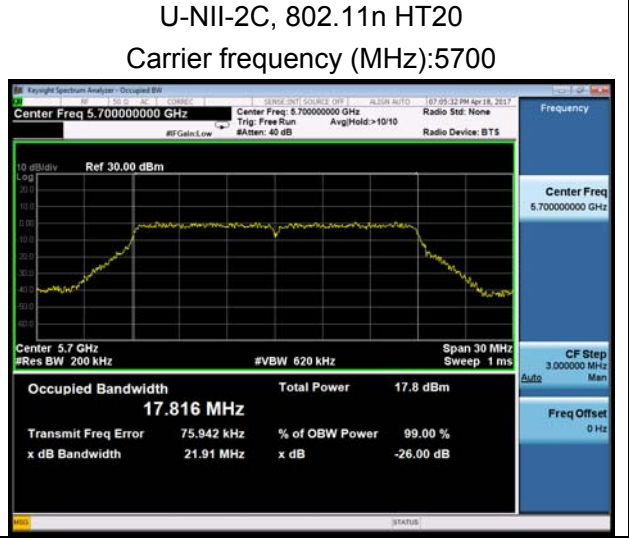
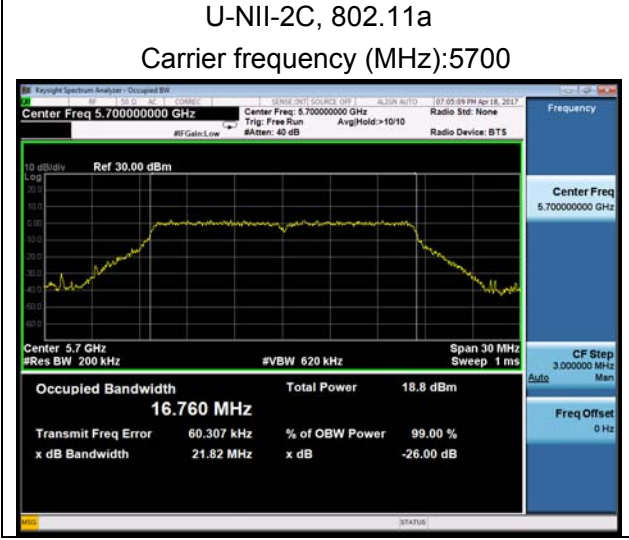
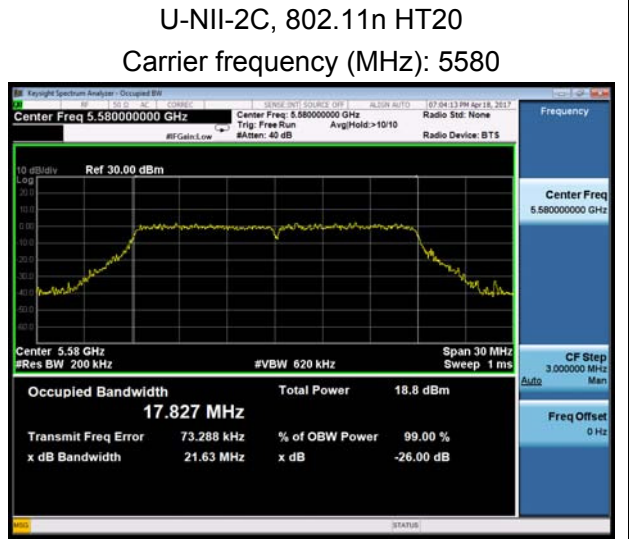
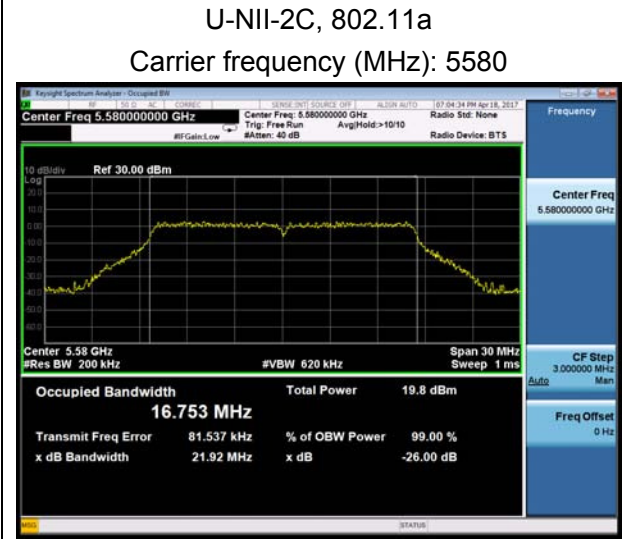
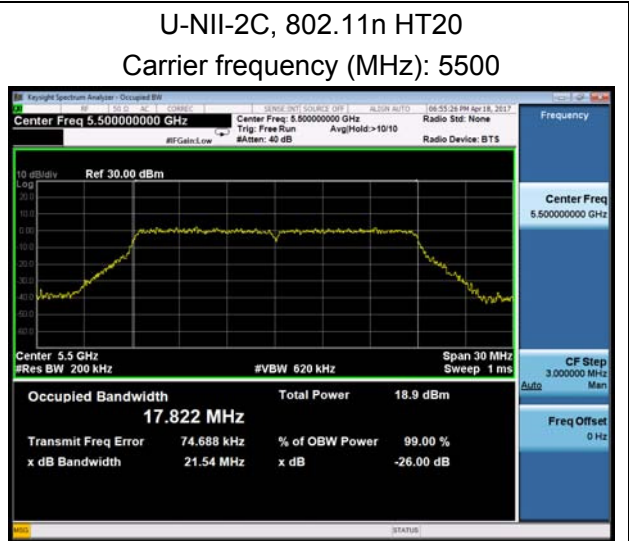
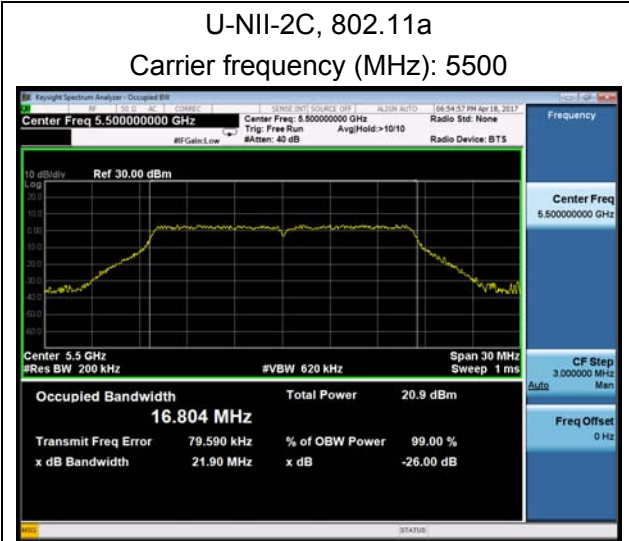



U-NII-2C, 802.11n HT40  
Carrier frequency (MHz): 5510



U-NII-2C, 802.11ac HT20  
Carrier frequency (MHz): 5500

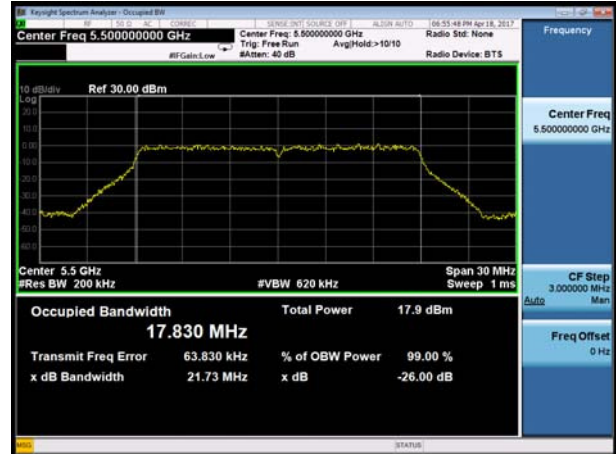

U-NII-2C, 802.11n HT40  
Carrier frequency (MHz): 5670



U-NII-2C, 802.11ac HT20  
Carrier frequency (MHz): 5580

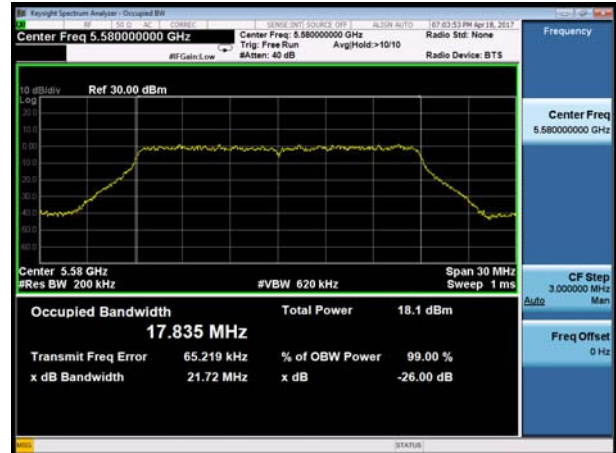

U-NII-2C, 802.11ac HT20  
Carrier frequency (MHz): 5700





U-NII-2C, 802.11ac HT40  
Carrier frequency (MHz): 5510



U-NII-2C, 802.11ac HT80  
Carrier frequency (MHz): 5530

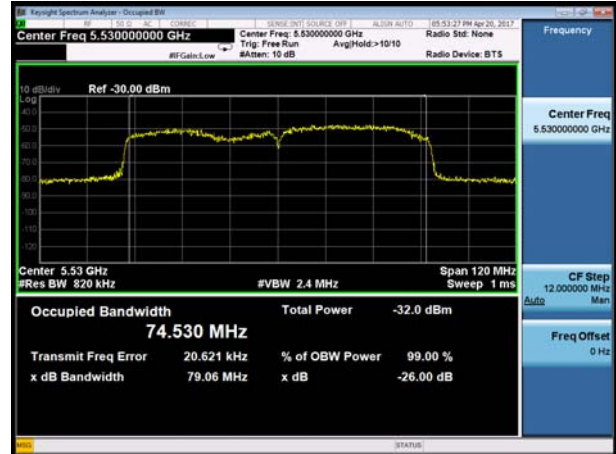

U-NII-2C, 802.11ac HT40  
Carrier frequency (MHz): 5670



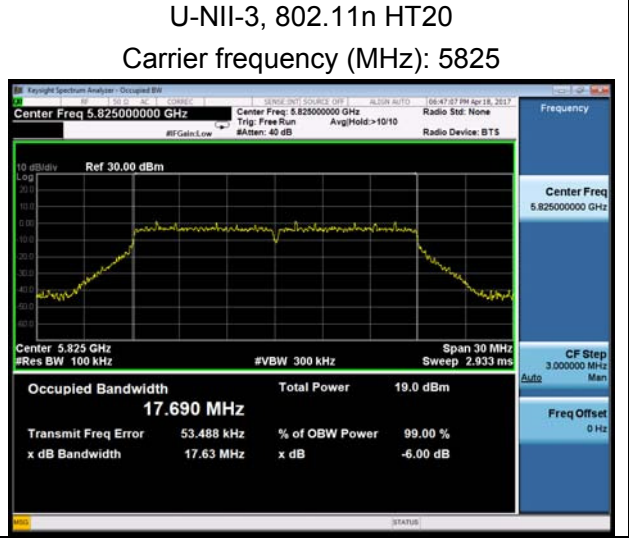
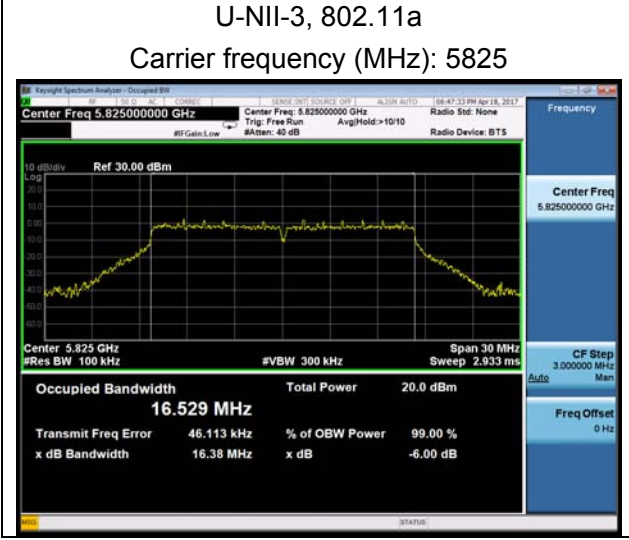
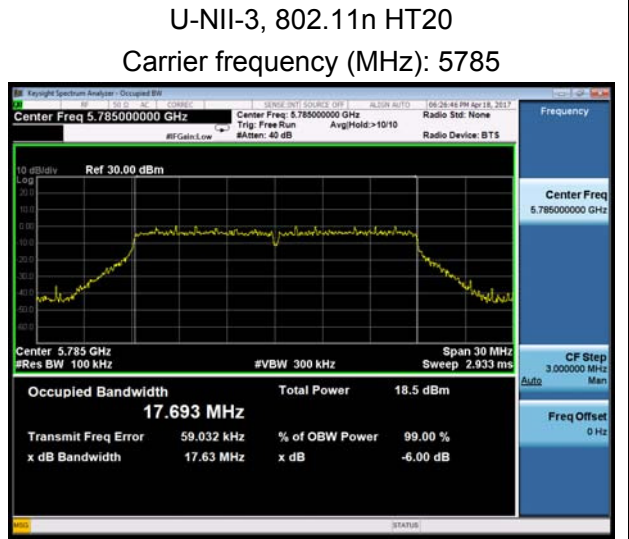
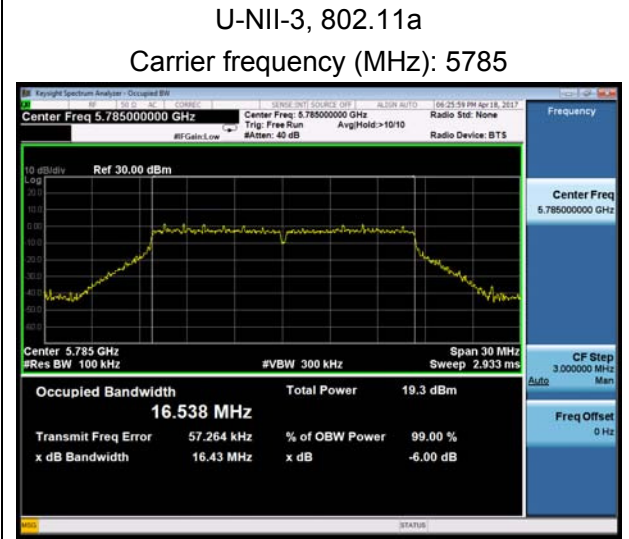
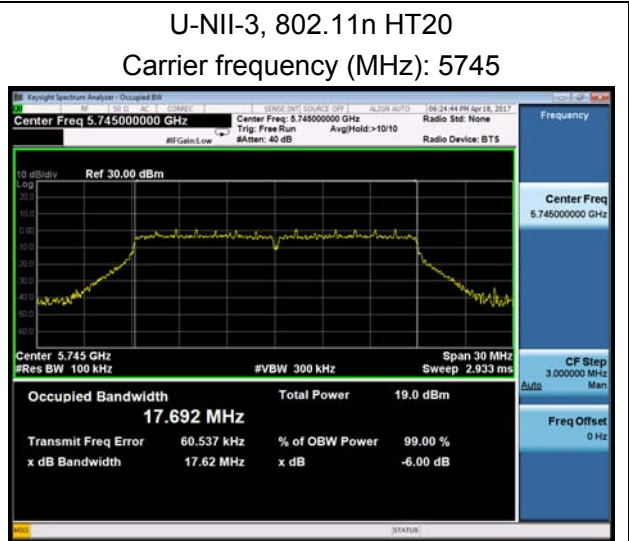
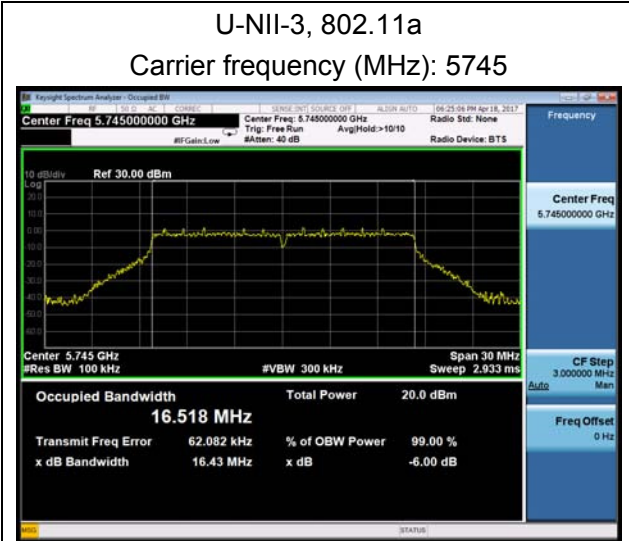



U-NII-3, 802.11n HT40  
Carrier frequency (MHz): 5755



U-NII-3, 802.11ac HT20  
Carrier frequency (MHz): 5745



U-NII-3, 802.11n HT40  
Carrier frequency (MHz): 5795



U-NII-3, 802.11ac HT20  
Carrier frequency (MHz): 5785

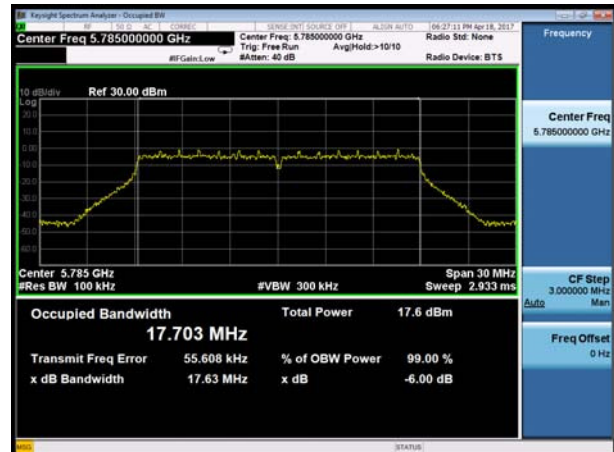

U-NII-3, 802.11ac HT20  
Carrier frequency (MHz): 5825





U-NII-3, 802.11ac HT40  
Carrier frequency (MHz): 5755

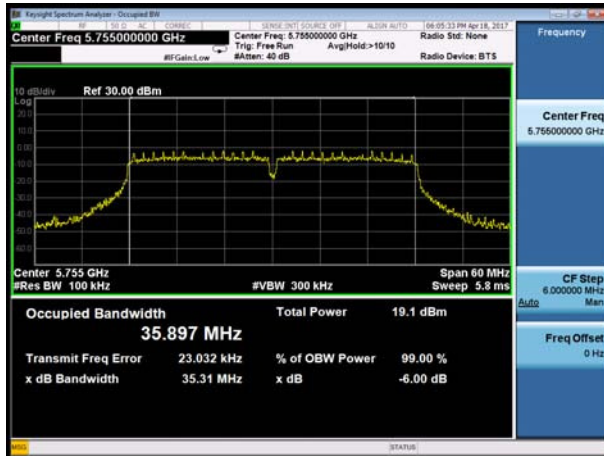

U-NII-3, 802.11ac HT80  
Carrier frequency (MHz): 5775

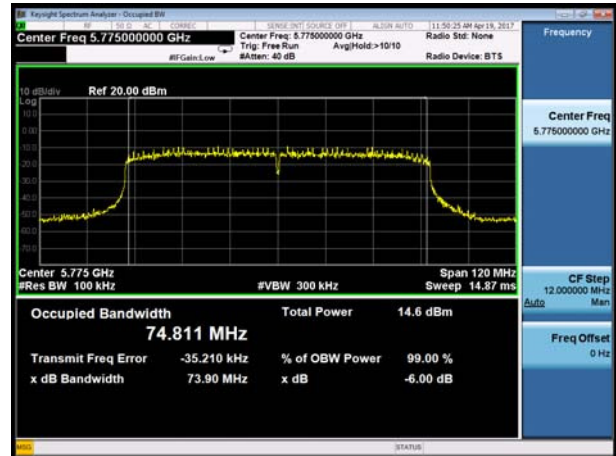

U-NII-3, 802.11ac HT40  
Carrier frequency (MHz): 5795





## 5.2. Average Power Output –Conducted

### Ambient condition

Temperature	Relative humidity	Pressure
23°C ~25°C	45%~50%	101.5kPa

### Methods of Measurement

During the process of the testing, The EUT was connected to the average power meter through an external attenuator and a known loss cable. The EUT is max power transmission with proper modulation. We use Maximum average Conducted Output Power Level Method in KDB789033 for this test

### Test Setup

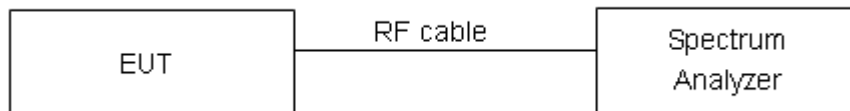

### Limits

Rule FCC Part 15.407(a)(1)(2)(3)

For client devices in the 5.15-5.25 GHz band, the maximum conducted output power over the frequency band of operation shall not exceed 250 mW provided the maximum antenna gain does not exceed 6 dBi. In addition, the maximum power spectral density shall not exceed 11 dBm in any 1 megahertz band. If transmitting antennas of directional gain greater than 6 dBi are used, both the maximum conducted output power and the maximum power spectral density shall be reduced by the amount in dB that the directional gain of the antenna exceeds 6 dBi.

For the 5.25-5.35 GHz and 5.47-5.725 GHz bands, the maximum conducted output power over the frequency bands of operation shall not exceed the lesser of 250 mW or 11 dBm + 10 log B, where B is the 26 dB emission bandwidth in megahertz. In addition, the maximum power spectral density shall not exceed 11 dBm in any 1 megahertz band. If transmitting antennas of directional gain greater than 6 dBi are used, both the maximum conducted output power and the maximum power spectral density shall be reduced by the amount in dB that the directional gain of the antenna exceeds 6 dBi.

For the band 5.725-5.85 GHz, the maximum conducted output power over the frequency band of operation shall not exceed 1 W. In addition, the maximum power spectral density shall not exceed 30 dBm in any 500-kHz band. If transmitting antennas of directional gain greater than 6 dBi are used, both the maximum conducted output power and the maximum power spectral density shall be reduced by the amount in dB that the directional gain of the antenna exceeds 6 dBi.

### Measurement Uncertainty

The assessed measurement uncertainty to ensure 95% confidence level for the normal distribution is with the coverage factor  $k = 2$ ,  $U = 0.44$  dB.



## Test Results

Network Standards		Channel/Frequency (MHz)	B=26 dB bandwidth (MHz)	Limit 11 dBm + 10 log B (dBm)	Final Limit(dBm)
U-NII-2A	802.11a	52/5260	21.42	24.31>24	24
		60/5300	21.87	24.40>24	24
		64/5320	21.52	24.33>24	24
	802.11n HT20	52/5260	21.87	24.40>24	24
		60/5300	21.84	24.39>24	24
		64/5320	21.97	24.42>24	24
	802.11n HT40	54/5270	39.47	26.96>24	24
		62/5310	40.53	27.08>24	24
	802.11ac HT20	52/5260	21.46	24.32>24	24
		60/5300	21.67	24.36>24	24
		64/5320	21.91	24.41>24	24
	802.11ac HT40	54/5270	39.36	26.95>24	24
		62/5310	39.59	26.98>24	24
802.11ac HT80	58/5290	78.66	29.96>24	24	
U-NII-2C	802.11a	100/5500	21.90	24.40>24	24
		116/5580	21.92	24.41>24	24
		140/5700	21.82	24.39>24	24
	802.11n HT20	100/5500	21.54	24.33>24	24
		116/5580	21.63	24.35>24	24
		140/5700	21.91	24.41>24	24
	802.11n HT40	102/5510	39.19	26.93>24	24
		110/5550	40.31	27.05>24	24
		134/5670	21.73	24.37>24	24
	802.11ac HT20	100/5500	21.72	24.37>24	24
		116/5580	21.79	24.38>24	24
		140/5700	39.66	26.98>24	24
	802.11ac HT40	102/5510	39.19	26.93>24	24
		110/5550	79.06	29.98>24	24
		134/5670	21.90	24.40>24	24
	802.11ac HT80	106/5530	21.92	24.41>24	24

Note: 250mW=24dBm

**U-NII-1**

Network Standards	Channel/Frequency (MHz)	Output Power (dBm)	Limit (dBm)	Conclusion
802.11a	36/5180	13.45	24	PASS
	40/5200	13.45	24	PASS
	48/5240	13.56	24	PASS
802.11n HT20	36/5180	12.35	24	PASS
	40/5200	12.91	24	PASS
	48/5240	12.14	24	PASS
802.11n HT40	38/5190	13.47	24	PASS
	46/5230	13.02	24	PASS
802.11ac HT20	36/5180	11.20	24	PASS
	40/5200	11.26	24	PASS
	48/5240	11.42	24	PASS
802.11ac HT40	38/5190	11.98	24	PASS
	46/5230	12.15	24	PASS
802.11ac HT80	42/5210	9.10	24	PASS

**U-NII-2A**

Network Standards	Channel/Frequency (MHz)	Output Power (dBm)	Limit (dBm)	Conclusion
802.11a	52/5260	13.19	24	PASS
	60/5300	13.02	24	PASS
	64/5320	12.28	24	PASS
802.11n HT20	52/5260	11.85	24	PASS
	60/5300	12.14	24	PASS
	64/5320	11.44	24	PASS
802.11n HT40	54/5270	12.79	24	PASS
	62/5310	12.47	24	PASS
802.11ac HT20	52/5260	10.94	24	PASS
	60/5300	10.81	24	PASS
	64/5320	10.51	24	PASS
802.11ac HT40	54/5270	12.01	24	PASS
	62/5310	11.77	24	PASS
802.11ac HT80	58/5290	8.81	24	PASS



## U-NII-2C

Network Standards	Channel/ Frequency (MHz)	Output Power (dBm)	Limit (dBm)	Conclusion
802.11a	100/5500	13.25	24	PASS
	116/5580	12.73	24	PASS
	140/5700	11.71	24	PASS
802.11n HT20	100/5500	11.11	24	PASS
	116/5580	12.08	24	PASS
	140/5700	11.27	24	PASS
802.11n HT40	102/5510	12.30	24	PASS
	134/5670	11.50	24	PASS
802.11ac HT20	100/5500	10.48	24	PASS
	116/5580	10.36	24	PASS
	140/5700	10.05	24	PASS
802.11ac HT40	102/5510	11.11	24	PASS
	134/5670	10.48	24	PASS
802.11ac HT80	106/5530	8.25	24	PASS

## U-NII-3

Network Standards	Channel/ Frequency (MHz)	Output Power (dBm)	Limit (dBm)	Conclusion
802.11a	149/5745	12.78	24	PASS
	157/5785	12.72	24	PASS
	165/5825	12.46	24	PASS
802.11n HT20	149/5745	11.76	24	PASS
	157/5785	11.68	24	PASS
	165/5825	11.47	24	PASS
802.11n HT40	151/5755	11.87	24	PASS
	159/5795	11.42	24	PASS
802.11ac HT20	149/5745	11.04	24	PASS
	157/5785	10.89	24	PASS
	165/5825	11.01	24	PASS
802.11ac HT40	151/5755	11.04	24	PASS
	159/5795	10.41	24	PASS
802.11ac HT80	155/5775	8.22	24	PASS

### 5.3. Frequency Stability

#### Ambient condition

Temperature	Relative humidity	Pressure
23°C ~25°C	45%~50%	101.5kPa

#### Method of Measurement

1. Frequency stability with respect to ambient temperature

a) Supply the EUT with a nominal ac voltage or install a new or fully charged battery in the EUT. If possible, a dummy load shall be connected to the EUT because an antenna near the metallic walls of an environmental test chamber could affect the output frequency of the EUT. If the EUT is equipped with a permanently attached, adjustable-length antenna, then the EUT shall be placed in the center of the chamber with the antenna adjusted to the shortest length possible. Turn ON the EUT and tune it to one of the number of frequencies shown in 5.6.

b) Couple the unlicensed wireless device output to the measuring instrument by connecting an antenna to the measuring instrument with a suitable length of coaxial cable and placing the measuring antenna near the EUT (e.g., 15 cm away), or by connecting a dummy load to the measuring instrument, through an attenuator if necessary.

c) Adjust the location of the measurement antenna and the controls on the measurement instrument to obtain a suitable signal level (i.e., a level that will not overload the measurement instrument but is strong enough to allow measurement of the operating or fundamental frequency of the EUT).

d) Turn the EUT OFF and place it inside the environmental temperature chamber. For devices that have oscillator heaters, energize only the heater circuit.

e) Set the temperature control on the chamber to the highest specified in the regulatory requirements for the type of device and allow the oscillator heater and the chamber temperature to stabilize.

f) While maintaining a constant temperature inside the environmental chamber, turn the EUT ON and record the operating frequency at startup, and at 2 minutes, 5 minutes, and 10 minutes after the EUT is energized. Four measurements in total are made.

g) Measure the frequency at each of frequencies specified in 5.6.

h) Switch OFF the EUT but do not switch OFF the oscillator heater.

i) Lower the chamber temperature by not more than 10 C, and allow the temperature inside the chamber to stabilize.

j) Repeat step f) through step i) down to the lowest specified temperature.

2. Frequency stability when varying supply voltage

Unless otherwise specified, these tests shall be made at ambient room temperature (+15°C to +25°C). An antenna shall be connected to the antenna output terminals of the EUT if possible. If the EUT is equipped with or uses an adjustable-length antenna, then it shall be fully extended.

a) Supply the EUT with nominal voltage or install a new or fully charged battery in the EUT. Turn ON the EUT and couple its output to a frequency counter or other frequency-measuring instrument.

- b) Tune the EUT to one of the number of frequencies required in 5.6. Adjust the location of the measurement antenna and the controls on the measurement instrument to obtain a suitable signal level (i.e., a level that will not overload the measurement instrument but is strong enough to allow measurement of the operating or fundamental frequency of the EUT).
- c) Measure the frequency at each of the frequencies specified in 5.6.
- d) Repeat the above procedure at 85% and 115% of the nominal supply voltage.

**Limit**

Manufacturers of U-NII devices are responsible for ensuring frequency stability such that an emission is maintained within the band of operation under all conditions of normal operation as specified in the users manual.

**Measurement Uncertainty**

The assessed measurement uncertainty to ensure 95% confidence level for the normal distribution is with the coverage factor  $k = 2$ ,  $U = 936\text{Hz}$

**Test Results**

Voltage (V)	Temperature (°C)	U-NII-1 Test Results			
		5200MHz			
		1min	2min	5min	10min
5.00	-20	5199.994247	5199.990017	5199.989124	5199.987781
5.00	-10	5200.002817	5199.982179	5199.986139	5199.985582
5.00	0	5199.993484	5199.972895	5199.983346	5199.984952
5.00	10	5199.992345	5199.967824	5199.974153	5199.976649
5.00	20	5199.985127	5199.966945	5199.972357	5199.972506
5.00	30	5199.981073	5199.957271	5199.967636	5199.963145
5.00	40	5199.977674	5199.950033	5199.963549	5199.960967
5.00	50	5199.969733	5199.947768	5199.962089	5199.955377
4.75	20	5199.966344	5199.943933	5199.960358	5199.950817
5.25	20	5199.958675	5199.937688	5199.953966	5199.950498
MHz		-0.041325	-0.062312	-0.046034	-0.049502
PPM		-7.947086	-11.983125	-8.852617	-9.519653

Voltage (V)	Temperature (°C)	U-NII-2A Test Results			
		5300MHz			
		1min	2min	5min	10min
5.00	-20	5299.990250	5299.982961	5299.975850	5299.974341
5.00	-10	5299.982485	5299.980938	5299.973006	5299.969338
5.00	0	5299.979786	5299.973152	5299.969199	5299.965125
5.00	10	5299.970518	5299.968492	5299.968444	5299.962822
5.00	20	5299.968095	5299.961148	5299.960091	5299.956465
5.00	30	5299.961178	5299.959688	5299.955485	5299.950458
5.00	40	5299.953398	5299.954843	5299.945726	5299.940854
5.00	50	5299.953257	5299.954057	5299.942536	5299.933466
4.75	20	5299.950301	5299.949472	5299.934852	5299.923747
5.25	20	5299.944686	5299.944706	5299.927301	5299.915986
MHz		-0.055314	-0.055294	-0.072699	-0.084014
PPM		-10.436675	-10.432848	-13.716752	-15.851768



Voltage (V)	Temperature (°C)	U-NII-2C Test Results			
		5580MHz			
		1min	2min	5min	10min
5.00	-20	5579.992752	5579.992426	5579.991878	5579.987890
5.00	-10	5579.986460	5579.986045	5579.988806	5579.987601
5.00	0	5579.984340	5579.979571	5579.987955	5579.980212
5.00	10	5579.983255	5579.971097	5579.985940	5579.976891
5.00	20	5579.980516	5579.964702	5579.978184	5579.969305
5.00	30	5579.973743	5579.962687	5579.975131	5579.965076
5.00	40	5579.965011	5579.953560	5579.965133	5579.959248
5.00	50	5579.956599	5579.945592	5579.962720	5579.958014
4.75	20	5579.948889	5579.936967	5579.962496	5579.953578
5.25	20	5579.939256	5579.927366	5579.960288	5579.953532
MHz		-0.060744	-0.072634	-0.039712	-0.046468
PPM		-10.886027	-13.016818	-7.116875	-8.327608

Voltage (V)	Temperature (°C)	U-NII-3 Test Results			
		5785MHz			
		1min	2min	5min	10min
5.00	-20	5784.997292	5784.993554	5784.989166	5784.981091
5.00	-10	5784.991915	5784.992704	5784.986613	5784.972935
5.00	0	5784.986216	5784.985720	5784.985221	5784.964902
5.00	10	5784.985431	5784.984469	5784.976551	5784.960206
5.00	20	5784.980608	5784.980433	5784.976269	5784.958543
5.00	30	5784.979321	5784.976354	5784.972405	5784.955857
5.00	40	5784.977387	5784.975465	5784.969491	5784.946492
5.00	50	5784.975762	5784.973909	5784.959612	5784.944798
4.75	20	5784.967306	5784.965425	5784.956261	5784.939358
5.25	20	5784.961324	5784.963091	5784.954651	5784.934734
MHz		-0.038676	-0.036909	-0.045349	-0.065266
PPM		-6.685604	-6.380132	-7.839125	-11.281947



### 5.4. Power Spectral Density

#### Ambient condition

Temperature	Relative humidity	Pressure
23°C ~25°C	45%~50%	101.5kPa

#### Method of Measurement

The EUT was connected to the spectrum analyzer through an external attenuator (20dB) and a known loss cable.

Set RBW = 500 kHz, VBW =1.5MHz for the band 5.725-5.85 GHz

Set RBW = 1 MHz, VBW =3MHz for the band 5.150-5.250 GHz

The conducted PSD is measured at each antenna port. The measured results at the various antenna ports are then summed mathematically.

#### Test setup

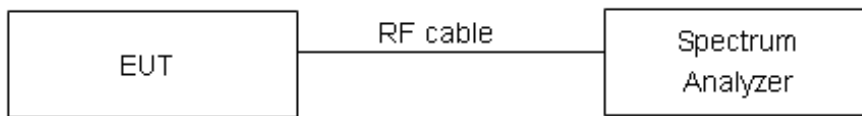

#### Limits

Rule FCC Part 15.407(a)(1)/ Part 15.407(a)(2) / Part 15.407(a)(3)

For an indoor access point operating in the band 5.15-5.25 GHz, the maximum power spectral density shall not exceed 17 dBm in any 1 megahertz band. If transmitting antennas of directional gain greater than 6 dBi are used, both the maximum conducted output power and the maximum power spectral density shall be reduced by the amount in dB that the directional gain of the antenna exceeds 6 dBi.

For the 5.25-5.35 GHz and 5.47-5.725 GHz bands, the maximum power spectral density shall not exceed 11 dBm in any 1 megahertz band. If transmitting antennas of directional gain greater than 6 dBi are used, both the maximum conducted output power and the maximum power spectral density shall be reduced by the amount in dB that the directional gain of the antenna exceeds 6 dBi.

For the band 5.725-5.85 GHz, the maximum power spectral density shall not exceed 30 dBm in any 500-kHz band. If transmitting antennas of directional gain greater than 6 dBi are used, both the maximum conducted output power and the maximum power spectral density shall be reduced by the amount in dB that the directional gain of the antenna exceeds 6 dBi.

Frequency Bands/MHz	Limits
5150-5250	17dBm/MHz
5.25-5.35 GHz and 5.47-5.725 GHz	11dBm/MHz
5725-5850	30dBm/500kHz

**Measurement Uncertainty**

The assessed measurement uncertainty to ensure 95% confidence level for the normal distribution is with the coverage factor  $k = 2$ ,  $U = 0.75\text{dB}$ .

**Test Results:****U-NII-1**

Network Standards	Channel Number	Power Spectral Density (dBm /MHz)	Limit (dBm /MHz)	Conclusion
802.11a	36	2.077	17	PASS
	40	2.238	17	PASS
	48	2.025	17	PASS
802.11n HT20	36	1.201	17	PASS
	40	0.886	17	PASS
	48	0.973	17	PASS
802.11n HT40	38	-2.101	17	PASS
	46	-1.644	17	PASS
802.11ac HT20	36	-0.449	17	PASS
	40	-0.456	17	PASS
	48	-0.138	17	PASS
802.11ac HT40	38	-2.523	17	PASS
	46	-2.295	17	PASS
802.11ac HT80	42	-7.751	17	PASS

**U-NII-2A**

Network Standards	Channel Number	Power Spectral Density (dBm /MHz)	Limit (dBm /MHz)	Conclusion
802.11a	52	2.104	11	PASS
	60	1.103	11	PASS
	64	0.923	11	PASS
802.11n HT20	52	0.728	11	PASS
	60	-0.107	11	PASS
	64	0.119	11	PASS
802.11n HT40	54	-1.621	11	PASS
	62	-2.201	11	PASS
802.11ac HT20	52	-0.510	11	PASS
	60	-0.963	11	PASS
	64	-0.925	11	PASS
802.11ac HT40	54	-2.206	11	PASS
	62	-2.917	11	PASS
802.11ac HT80	58	-9.034	11	PASS

**U-NII-2C**

Network Standards	Channel Number	Power Spectral Density (dBm /MHz)	Limit (dBm /MHz)	Conclusion
802.11a	100	1.779	11	PASS
	116	1.588	11	PASS
	140	0.662	11	PASS
802.11n HT20	100	0.984	11	PASS
	116	0.277	11	PASS
	140	-0.447	11	PASS
802.11n HT40	102	-1.708	11	PASS
	134	-2.977	11	PASS
802.11ac HT20	100	-0.585	11	PASS
	116	-0.321	11	PASS
	140	-1.627	11	PASS
802.11ac HT40	102	-3.212	11	PASS
	134	-3.633	11	PASS
802.11ac HT80	106	-9.821	11	PASS

**U-NII-3**

Network Standards	Channel Number	Power Spectral Density (dBm/500kHz)	Limit (dBm/500kHz)	Conclusion
802.11a	149	-1.417	30	PASS
	157	-2.526	30	PASS
	165	-1.239	30	PASS
802.11n HT20	149	-3.013	30	PASS
	157	-3.450	30	PASS
	165	-2.375	30	PASS
802.11n HT40	151	-4.728	30	PASS
	159	-5.688	30	PASS
802.11ac HT20	149	-3.789	30	PASS
	157	-4.369	30	PASS
	165	-3.538	30	PASS
802.11ac HT40	151	-6.257	30	PASS
	159	-6.948	30	PASS
802.11ac HT80	155	-12.228	30	PASS



U-NII-1, 802.11a, Channel No.: 36



U-NII-1, 802.11n HT20, Channel No.: 36



U-NII-1, 802.11a, Channel No.: 40



U-NII-1, 802.11n HT20, Channel No.: 40

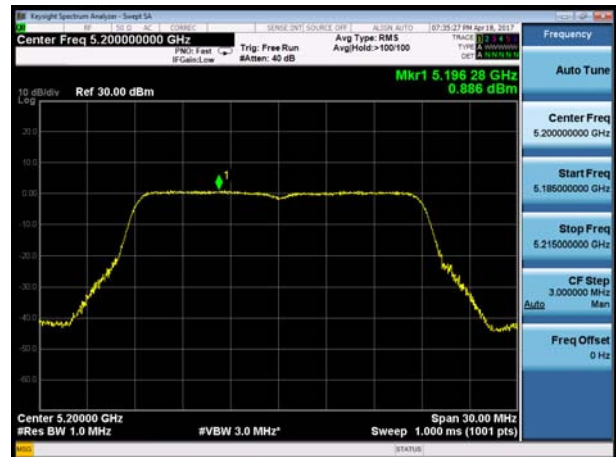

U-NII-1, 802.11a, Channel No.: 48



U-NII-1, 802.11n HT20, Channel No.: 48





U-NII-1, 802.11n HT40, Channel No.: 38



U-NII-1, 802.11ac HT20, Channel No.: 36



U-NII-1, 802.11n HT40, Channel No.: 46



U-NII-1, 802.11ac HT20, Channel No.: 40



U-NII-1, 802.11ac HT20, Channel No.: 48





### U-NII-1, 802.11ac HT40, Channel No.: 38



### U-NII-1, 802.11ac HT80, Channel No.: 42

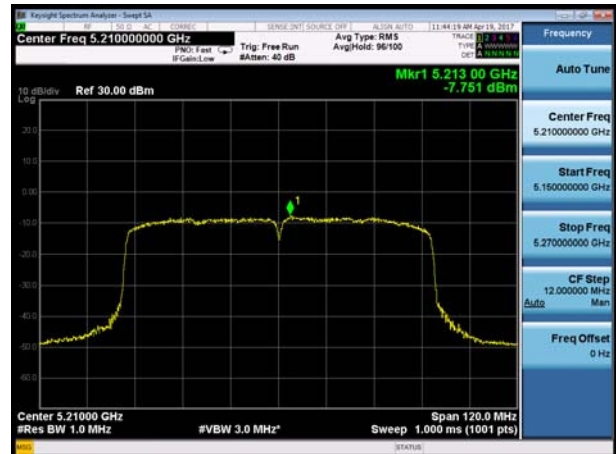

### U-NII-1, 802.11ac HT40, Channel No.: 46





U-NII-2A, 802.11a, Channel No.: 52

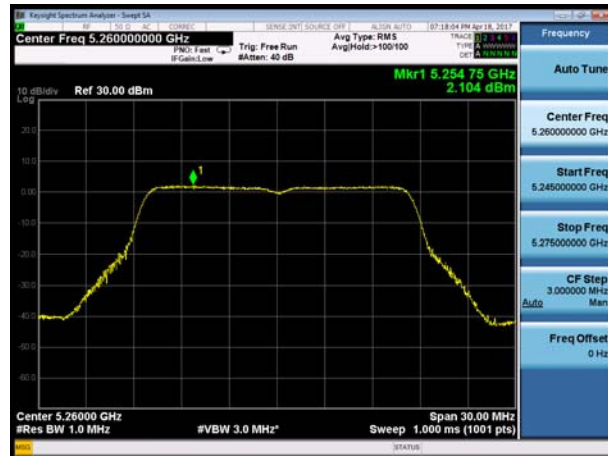

U-NII-2A, 802.11n HT20, Channel No.: 52

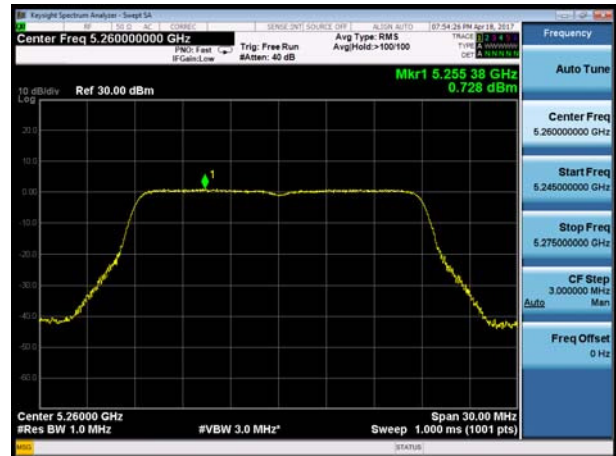

U-NII-2A, 802.11a, Channel No.: 60



U-NII-2A, 802.11n HT20, Channel No.: 60



U-NII-2A, 802.11a, Channel No.: 64

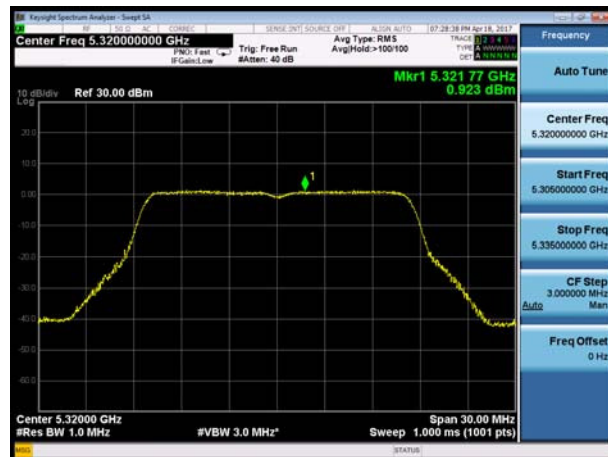

U-NII-2A, 802.11n HT20, Channel No.: 64







U-NII-2A, 802.11n HT40, Channel No.: 54



U-NII-2A, 802.11ac HT20, Channel No.:52

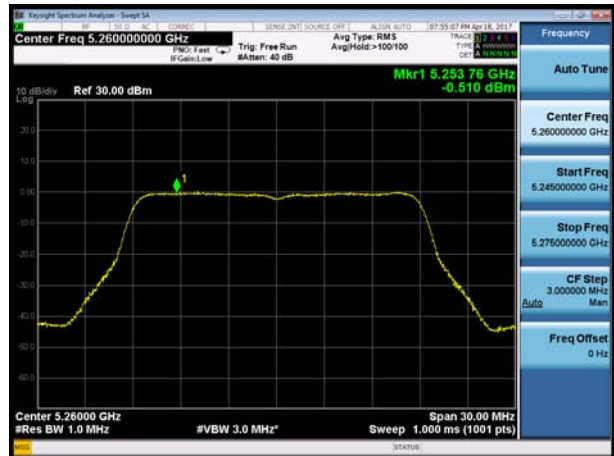

U-NII-2A, 802.11n HT40, Channel No.: 62

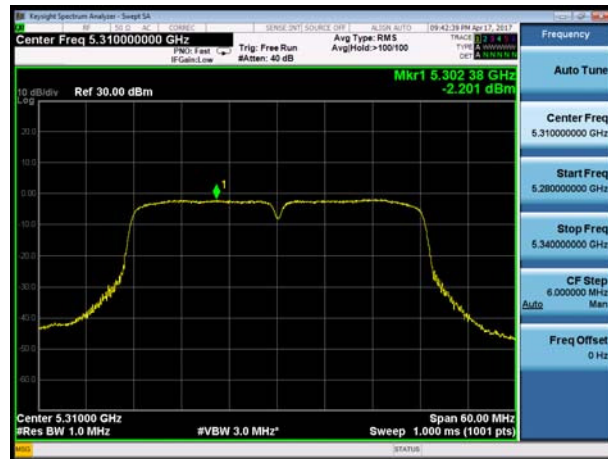

U-NII-2A, 802.11ac HT20, Channel No.: 60



U-NII-2A, 802.11ac HT20, Channel No.: 64





U-NII-2A, 802.11ac HT40, Channel No.: 54



U-NII-2A, 802.11ac HT80, Channel No.: 58



U-NII-2A, 802.11ac HT40, Channel No.: 62





U-NII-2C, 802.11a, Channel No.: 100

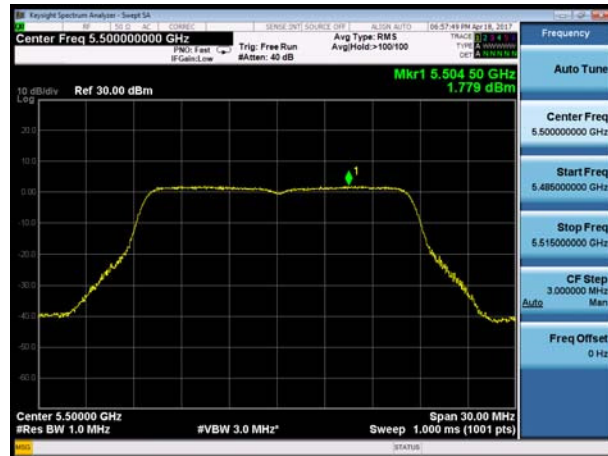

U-NII-2C, 802.11n HT20, Channel No.: 100



U-NII-2C, 802.11a, Channel No.: 116

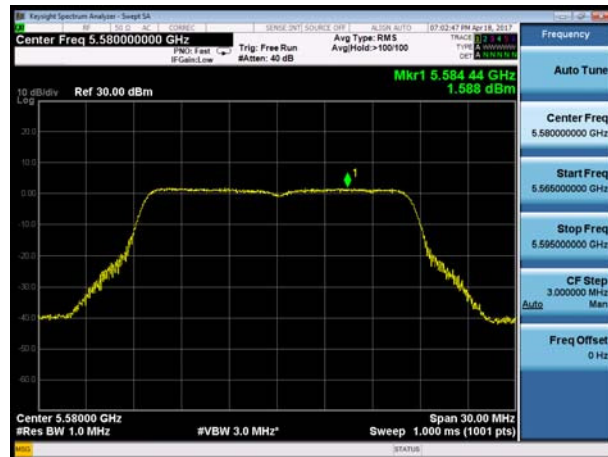

U-NII-2C, 802.11n HT20, Channel No.: 116

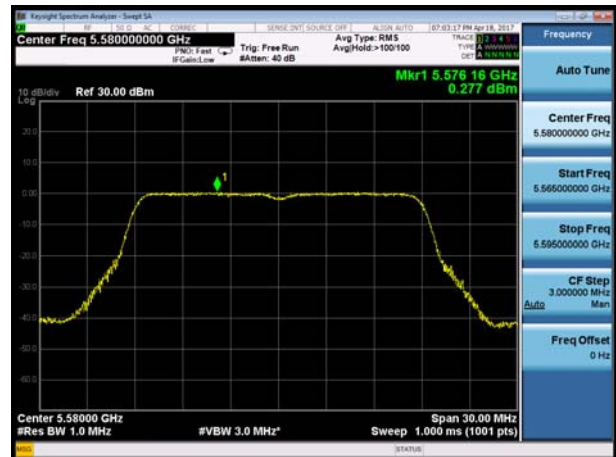

U-NII-2C, 802.11a, Channel No.: 140

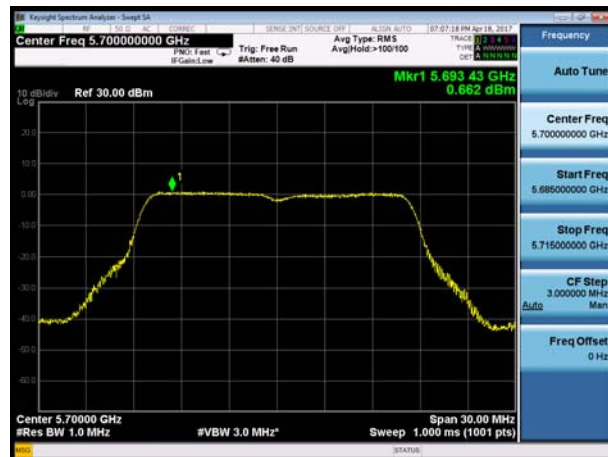

U-NII-2C, 802.11n HT20, Channel No.: 140





U-NII-2C, 802.11n HT40, Channel No.: 102

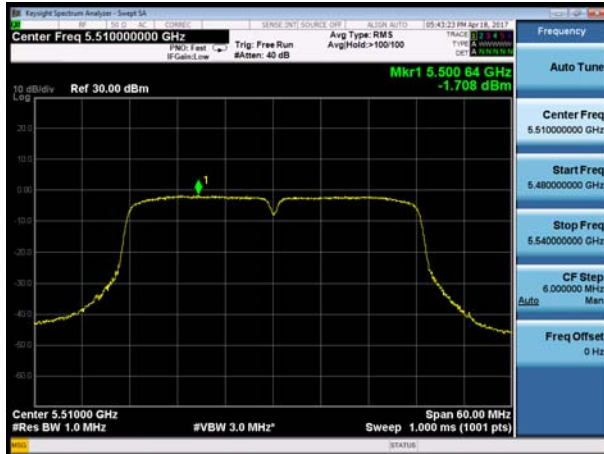

U-NII-2C, 802.11ac HT20, Channel No.: 100



U-NII-2C, 802.11n HT40, Channel No.: 134

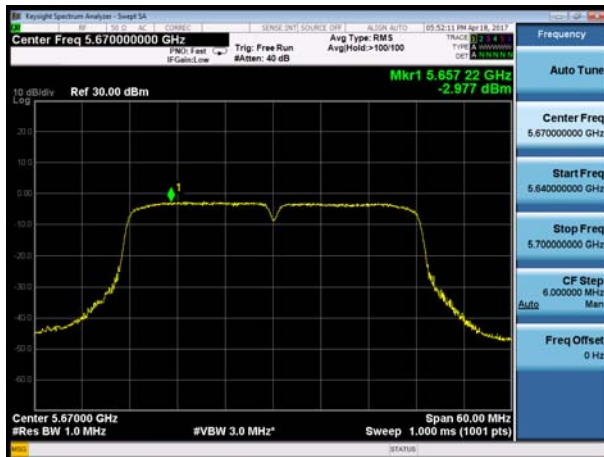

U-NII-2C, 802.11ac HT20, Channel No.: 116

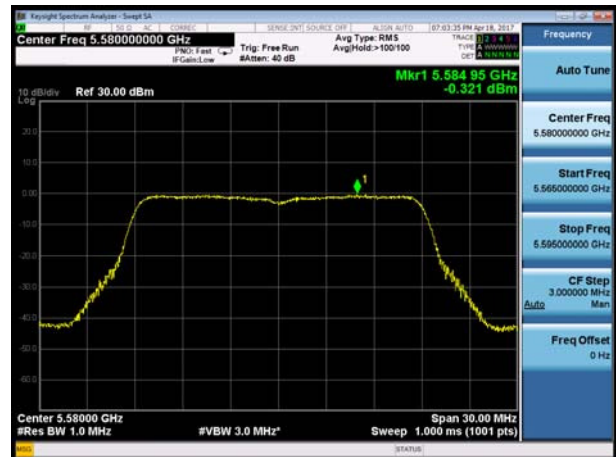

U-NII-2C, 802.11ac HT20, Channel No.: 140





U-NII-2C, 802.11ac HT40, Channel No.: 102



U-NII-2C, 802.11ac HT80, Channel No.: 106

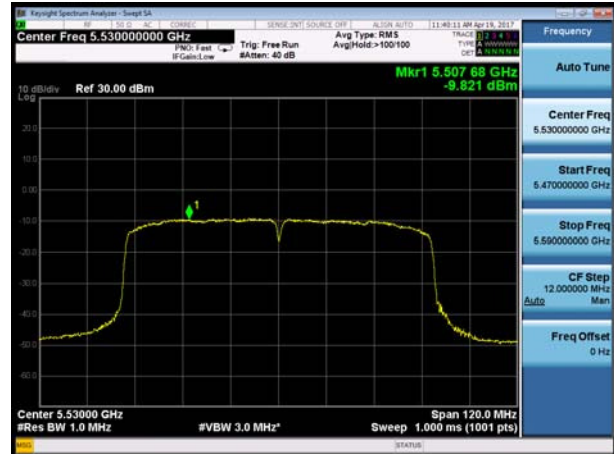

U-NII-2C, 802.11ac HT40, Channel No.: 134





U-NII-3, 802.11a, Channel No.: 149



U-NII-3, 802.11n HT20, Channel No.: 149



U-NII-3, 802.11a, Channel No.: 157



U-NII-3, 802.11n HT20, Channel No.: 157



U-NII-3, 802.11a, Channel No.: 165



U-NII-3, 802.11n HT20, Channel No.: 165





U-NII-3, 802.11n HT40, Channel No.: 151



U-NII-3, 802.11ac HT20, Channel No.: 149



U-NII-3, 802.11n HT40, Channel No.: 159

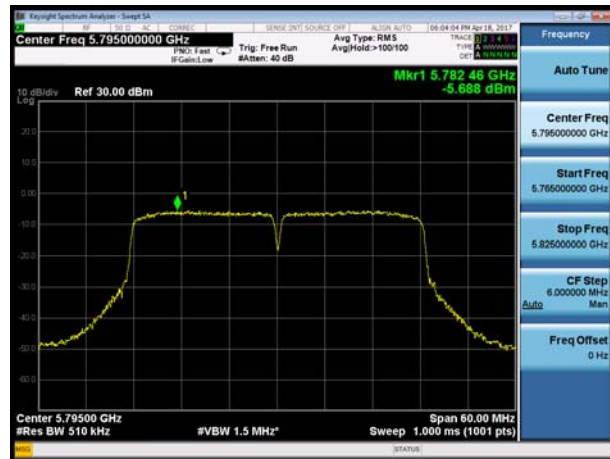

U-NII-3, 802.11ac HT20, Channel No.: 157



U-NII-3, 802.11ac HT20, Channel No.: 165





U-NII-3, 802.11ac HT40, Channel No.: 151

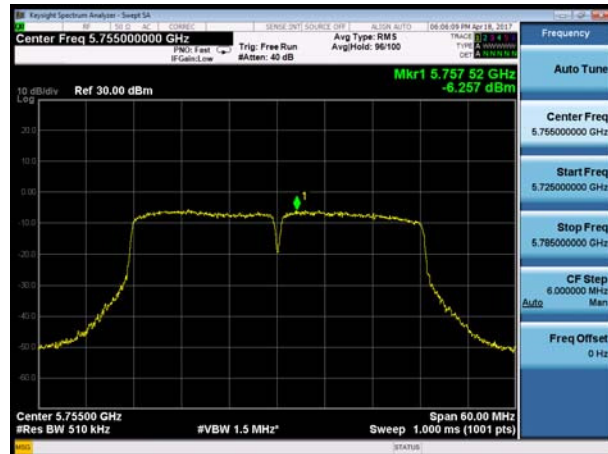

U-NII-3, 802.11ac HT80, Channel No.: 155



U-NII-3, 802.11ac HT40, Channel No.: 159

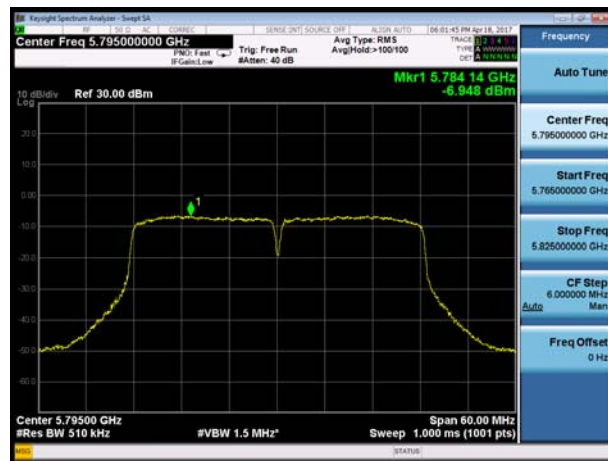



## 5.5. Unwanted Emission

### Ambient condition

Temperature	Relative humidity	Pressure
23°C ~25°C	45%~50%	101.5kPa

### Method of Measurement

The test set-up was made in accordance to the general provisions of ANSI C63.10-2013. The Equipment Under Test (EUT) was set up on a non-conductive table in the semi-anechoic chamber. The test was performed at the distance of 3 m between the EUT and the receiving antenna. The radiated emissions measurements were made in a typical installation configuration. Sweep the whole frequency band range from 9kHz to the 10th harmonic of the carrier, and the emissions less than 20 dB below the permissible value are reported.

During the test, the height of receive antenna shall be moved from 1 to 4 meters, and the antenna shall be performed under horizontal and vertical polarization. The turntable shall be rotated from 0 to 360 degrees for detecting the maximum of radiated spurious signal level. The measurements shall be repeated with orthogonal polarization of the test antenna. The data of cable loss and antenna factor has been calibrated in full testing frequency range before the testing.

Set the spectrum analyzer in the following:

Below 1GHz (detector: Peak and Quasi-Peak)

RBW=100kHz / VBW=300kHz / Sweep=AUTO

Above 1GHz (detector: Peak):

(a) PEAK: RBW=1MHz VBW=3MHz/ Sweep=AUTO

(b) AVERAGE: RBW=1MHz / VBW=3MHz / Sweep=AUTO

The radiated emission was measured in the following position: EUT stand-up position (Z axis), lie-down position (X, Y axis). The worst emission was found in stand-up position (Z axis) and the worst case was recorded.

The test is in transmitting mode.

9KHz~~~30MHz

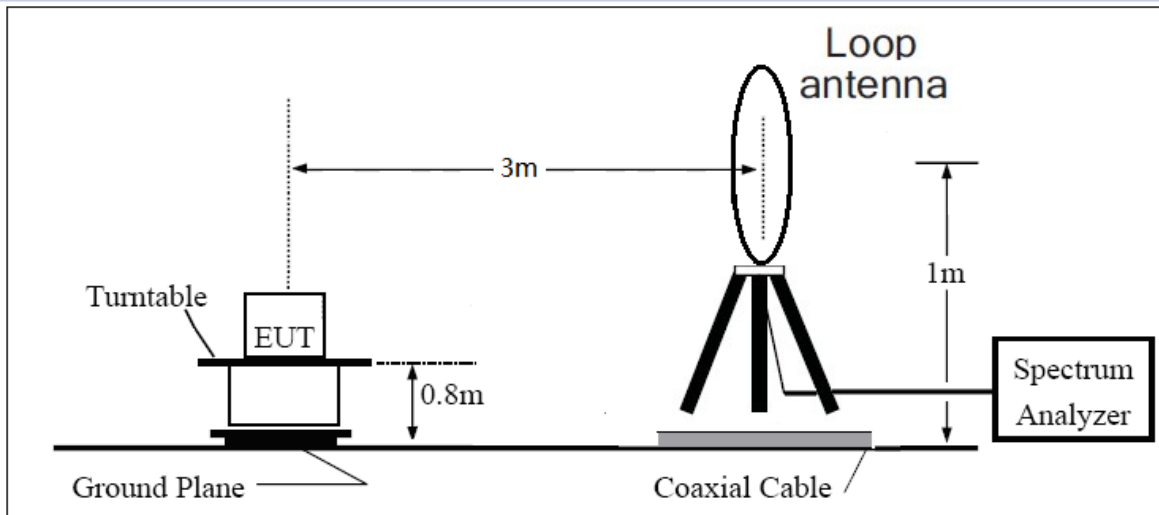

30MHz~~~ 1GHz

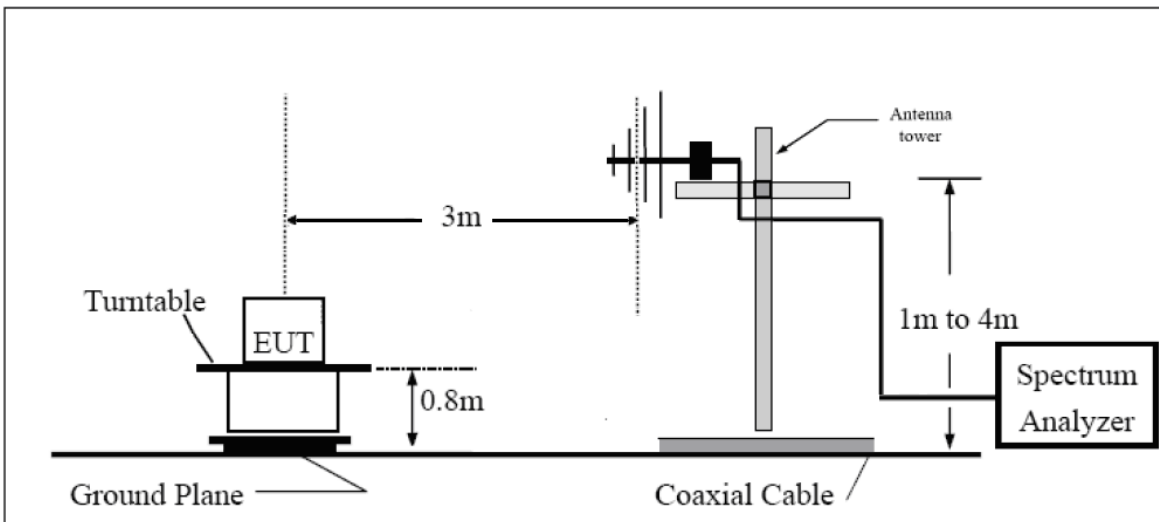

Above 1GHz

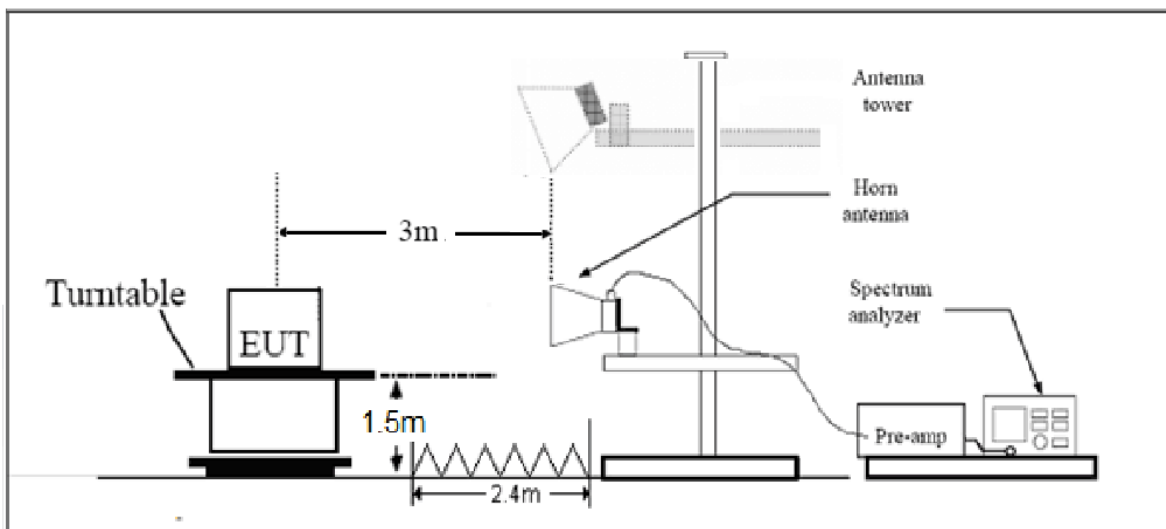

Note: Area side:2.4mX3.6m

**Limits**

- (1) For transmitters operating in the 5725-5850 MHz band: All emissions shall be limited to a level of -27 dBm/MHz at 75 MHz or more above or below the band edge increasing linearly to 10 dBm/MHz at 25 MHz above or below the band edge, and from 25 MHz above or below the band edge increasing linearly to a level of 15.6 dBm/MHz at 5 MHz above or below the band edge, and from 5 MHz above or below the band edge increasing linearly to a level of 27 dBm/MHz at the band edge.
- (2) For transmitters operating in the 5.15-5.25 GHz band: All emissions outside of the 5.15-5.35 GHz band shall not exceed an e.i.r.p. of -27 dBm/MHz(68.2dBμV/m).
- (3) For transmitters operating in the 5.25-5.35 GHz band: All emissions outside of the 5.15-5.35 GHz band shall not exceed an e.i.r.p. of -27 dBm/MHz(68.2dBμV/m).
- (4) For transmitters operating in the 5.47-5.725 GHz band: All emissions outside of the 5.47-5.725 GHz band shall not exceed an e.i.r.p. of -27 dBm/MHz(68.2dBμV/m).

Note: the following formula is used to convert the EIRP to field strength

§1、  $E[\text{dB}\mu\text{V}/\text{m}] = \text{EIRP}[\text{dBm}] - 20 \log(d[\text{meters}]) + 104.77$ , where E = field strength and

d = distance at which field strength limit is specified in the rules;

§2、  $E[\text{dB}\mu\text{V}/\text{m}] = \text{EIRP}[\text{dBm}] + 95.2$ , for d = 3 meters

- (5) Unwanted spurious emissions fallen in restricted bands per FCC Part15.205 shall comply with the general field strength limits set forth in § 15.209 as below table.

Frequency of emission (MHz)	Field strength(uV/m)	Field strength(dBuV/m)
0.009–0.490	2400/F(kHz)	/
0.490–1.705	24000/F(kHz)	/
1.705–30.0	30	/
30-88	100	40
88-216	150	43.5
216-960	200	46
Above960	500	54

MHz	MHz	MHz	GHz
0.090 - 0.110	16.42 - 16.423	399.9 - 410	4.5 - 5.15
0.495 - 0.505	16.69475 - 16.69525	608 - 614	5.35 - 5.46
2.1735 - 2.1905	16.80425 - 16.80475	960 - 1240	7.25 - 7.75
4.125 - 4.128	25.5 - 25.67	1300 - 1427	8.025 - 8.5
4.17725 - 4.17775	37.5 - 38.25	1435 - 1626.5	9.0 - 9.2
4.20725 - 4.20775	73 - 74.6	1645.5 - 1646.5	9.3 - 9.5
6.215 - 6.218	74.8 - 75.2	1660 - 1710	10.6 - 12.7
6.26775 - 6.26825	108 - 121.94	1718.8 - 1722.2	13.25 - 13.4
6.31175 - 6.31225	123 - 138	2200 - 2300	14.47 - 14.5
8.291 - 8.294	149.9 - 150.05	2310 - 2390	15.35 - 16.2
8.362 - 8.366	156.52475 - 156.52525	2483.5 - 2500	17.7 - 21.4
8.37625 - 8.38675	156.7 - 156.9	2690 - 2900	22.01 - 23.12
8.41425 - 8.41475	162.0125 - 167.17	3260 - 3267	23.6 - 24.0
12.29 - 12.293	167.72 - 173.2	3332 - 3339	31.2 - 31.8
12.51975 - 12.52025	240 - 285	3345.8 - 3358	36.43 - 36.5
12.57675 - 12.57725	322 - 335.4	3600 - 4400	( <sup>2</sup> )
13.36 - 13.41			

**Measurement Uncertainty**

The assessed measurement uncertainty to ensure 95% confidence level for the normal distribution is with the coverage factor  $k = 1.96$ .

Frequency	Uncertainty
9KHz-30MHz	3.55 dB
30MHz-200MHz	4.19 dB
200MHz-1GHz	3.63 dB
1GHz-26.5G	3.68 dB
26.5G-40GHz	4.76dB



**Test Results:**

The signal beyond the limit is carrier.

**U-NII-1**

**802.11a-Channel 36: Peak**

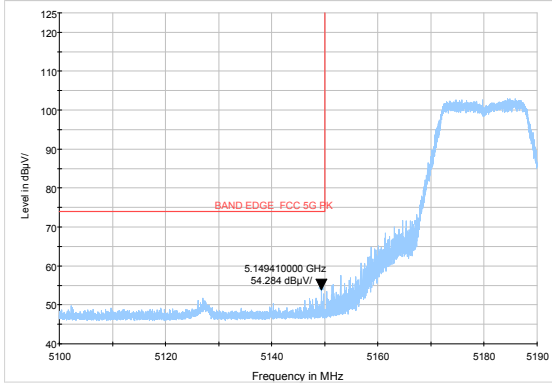

**802.11a-Channel 48: Peak**

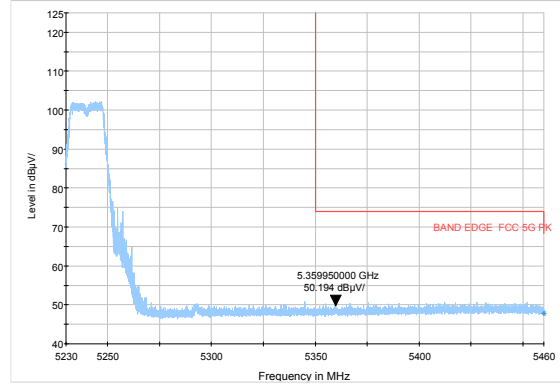

**802.11a-Channel 36: Average**

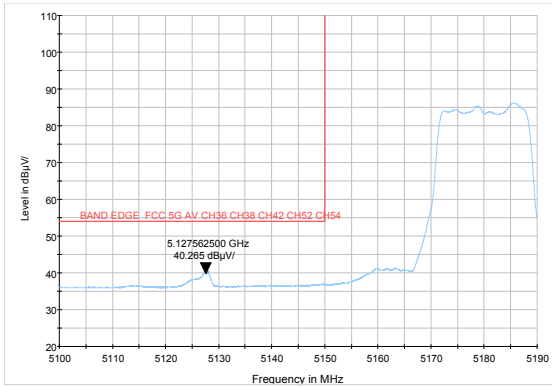

**802.11a-Channel 48: Average**

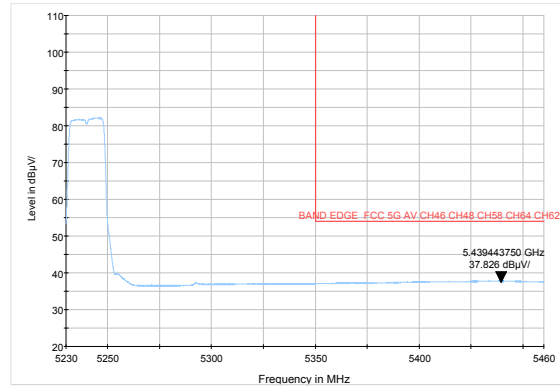

**802.11n HT20-Channel 36: Peak**

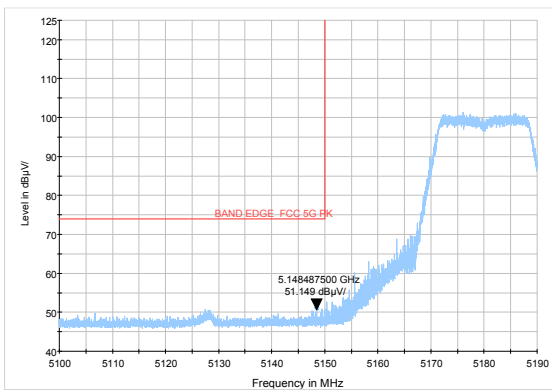

**802.11n HT20-Channel 48: Peak**

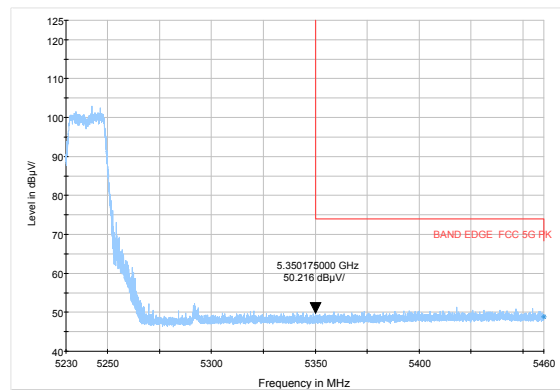



802.11n HT20-Channel 36: Average

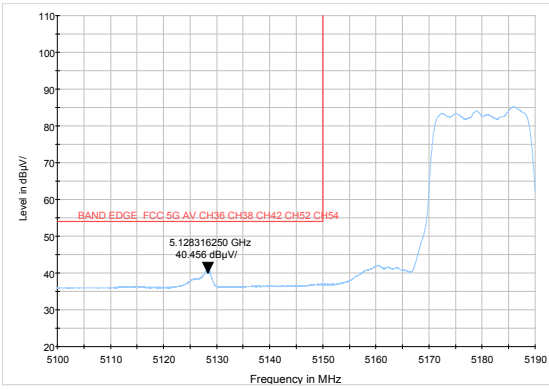

802.11n HT20-Channel 48: Average

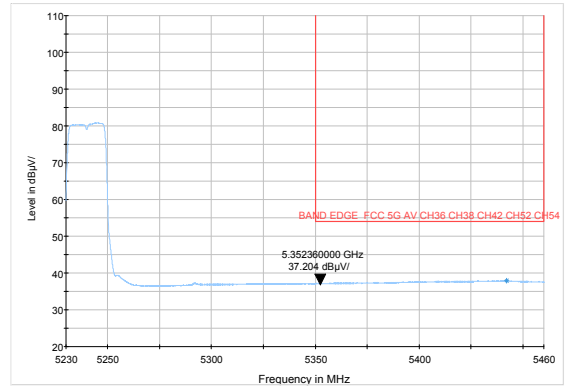

802.11n HT40-Channel 38: Peak

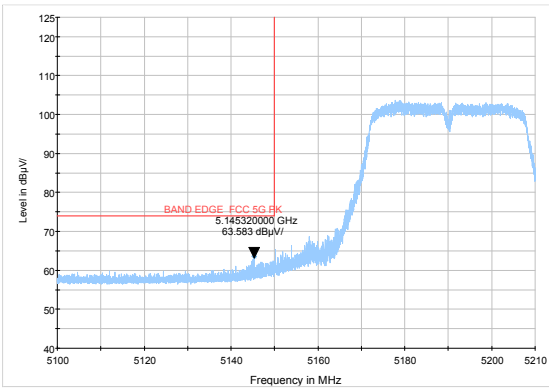

802.11n HT40-Channel 46: Peak

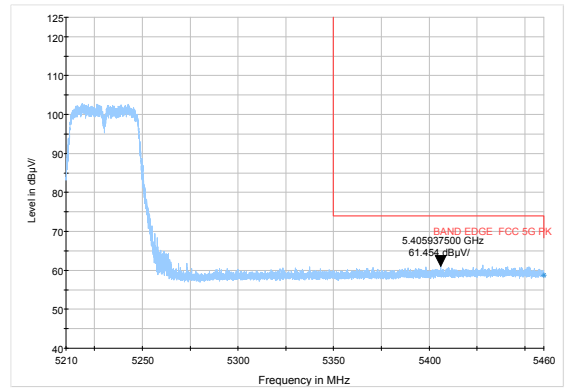

802.11n HT40-Channel 38: Average

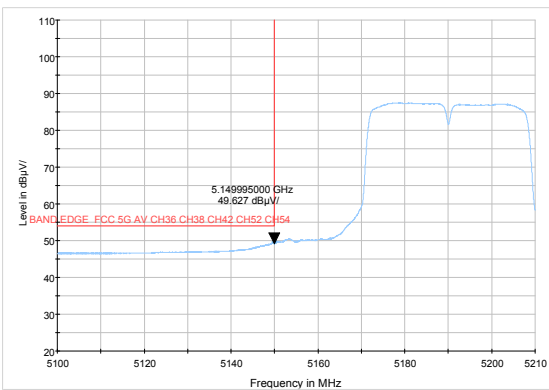

802.11n HT40-Channel 46: Average

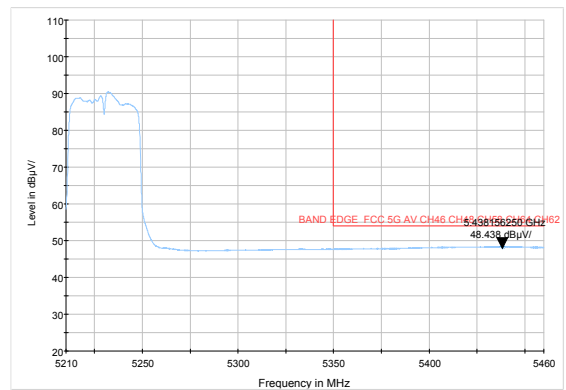



802.11ac HT20 -Channel 36: Peak

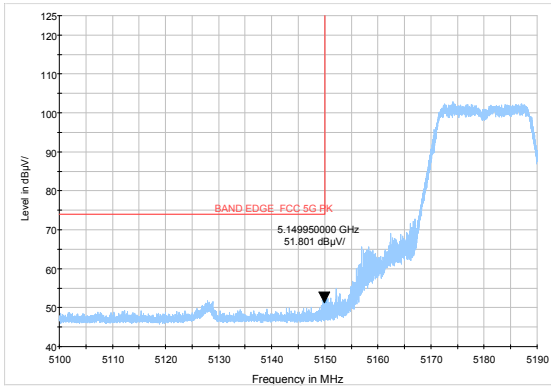

802.11ac HT20 -Channel 48: Peak

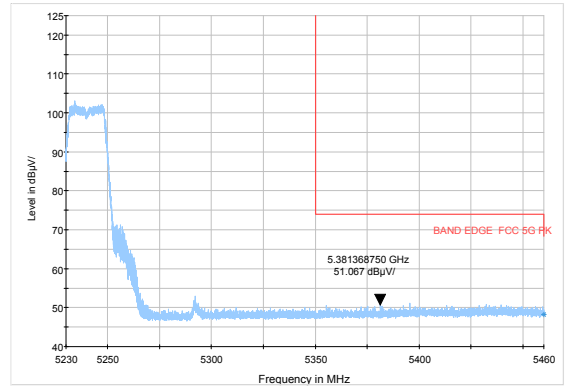

802.11ac HT20-Channel 36: Average

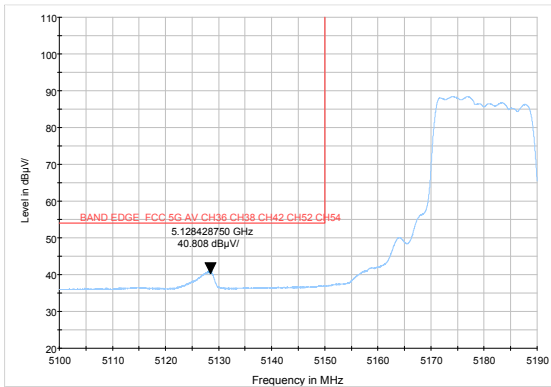

802.11ac HT20 -Channel 48: Average

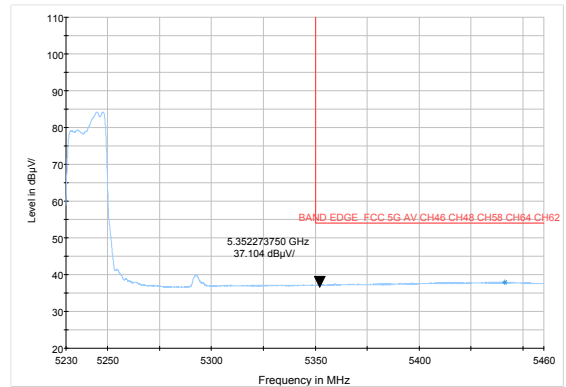

802.11ac HT40-Channel 38: Peak

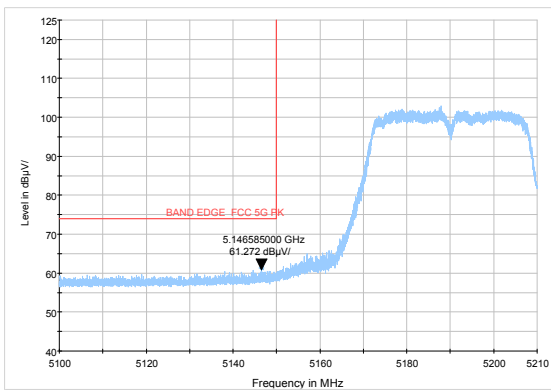

802.11ac HT40-Channel 46: Peak

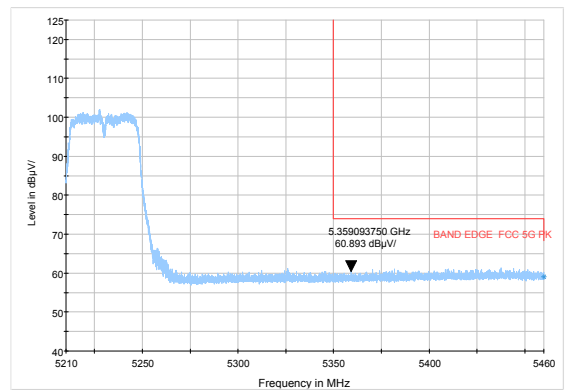



802.11ac HT40-Channel 38: Average

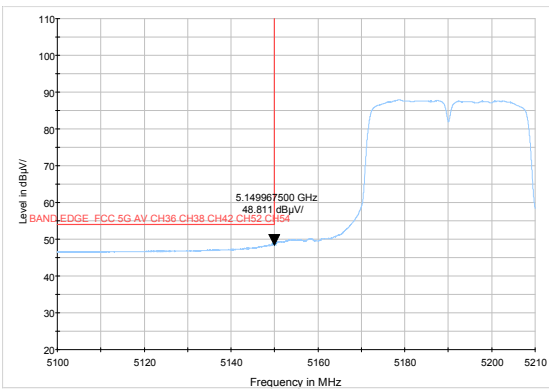

802.11ac HT40-Channel 46: Average

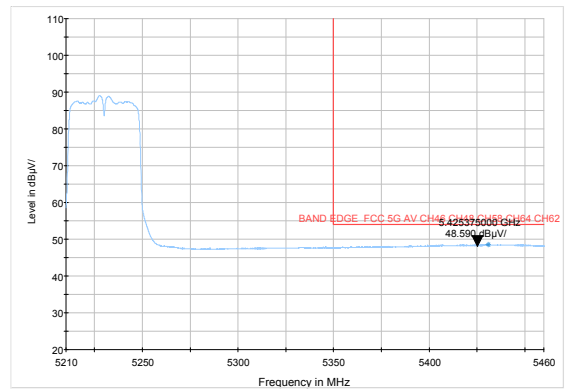

802.11ac HT80 -Channel 42: Peak

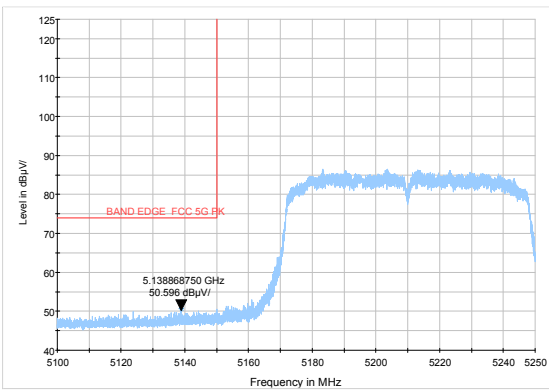

802.11ac HT80- Channel 42: Average

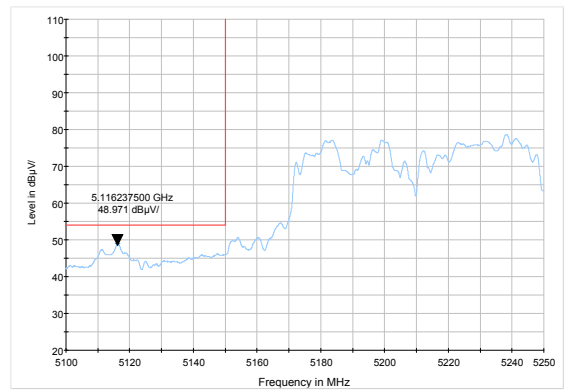





U-NII-2A

802.11a-Channel 52: Peak

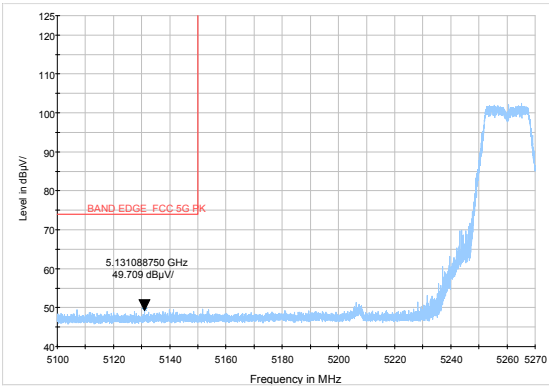

802.11a-Channel 64: Peak

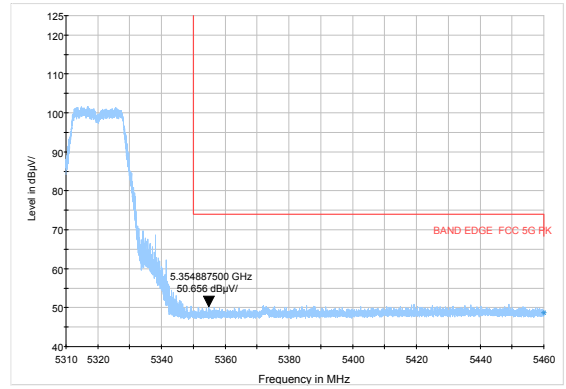

802.11a-Channel 52: Average

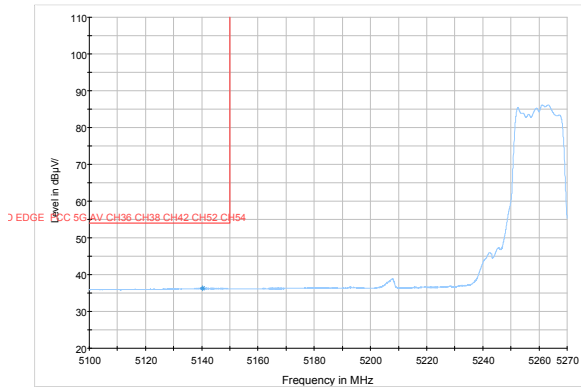

802.11a-Channel 64: Average

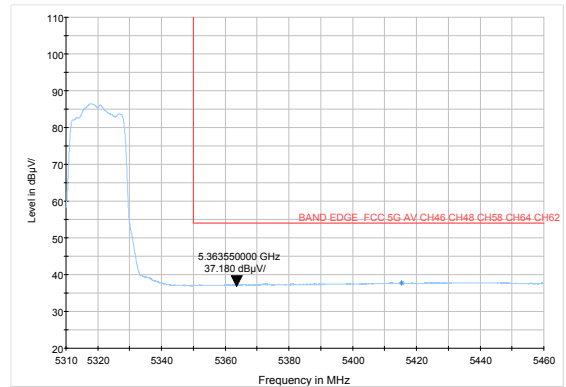

802.11n HT20-Channel 52: Peak

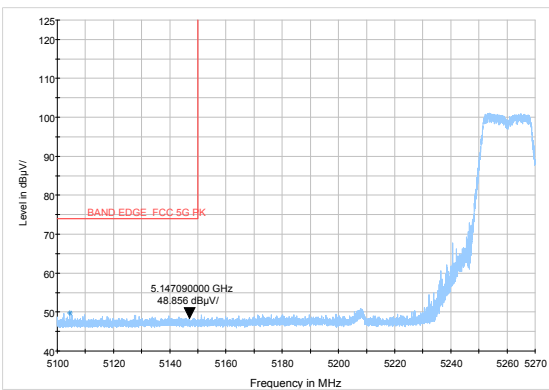

802.11n HT20-Channel 64: Peak

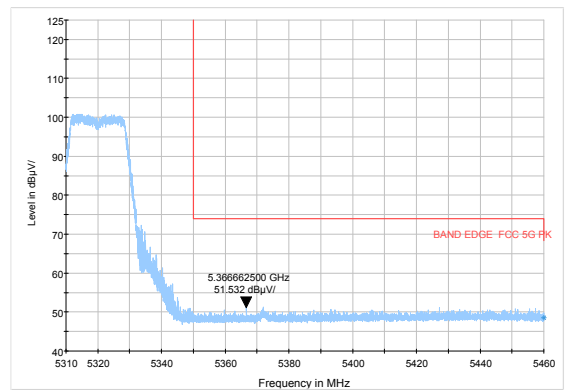

**802.11n HT20-Channel 52: Average**

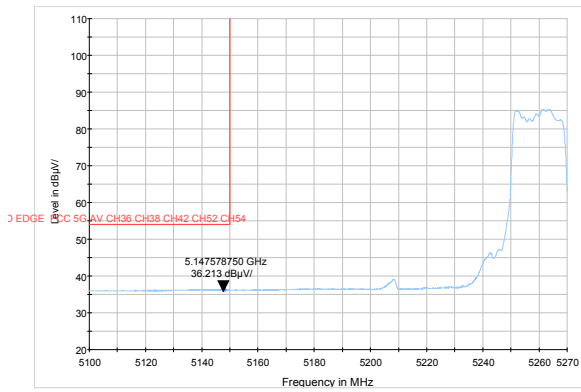

**802.11n HT20-Channel 64: Average**

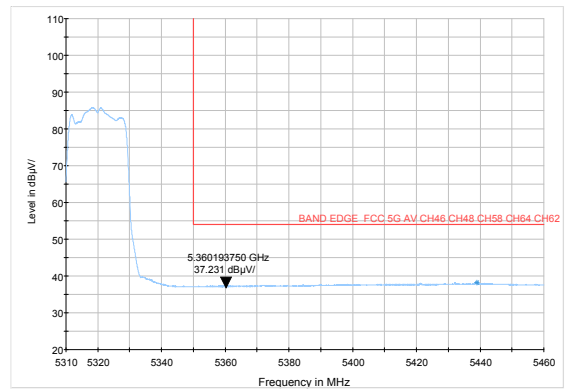

**802.11n HT40-Channel 54: Peak**

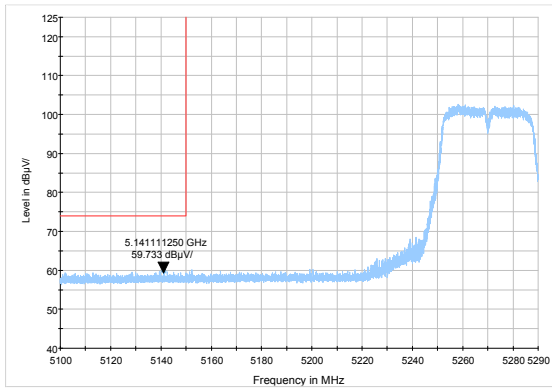

**802.11n HT40-Channel 62: Peak**

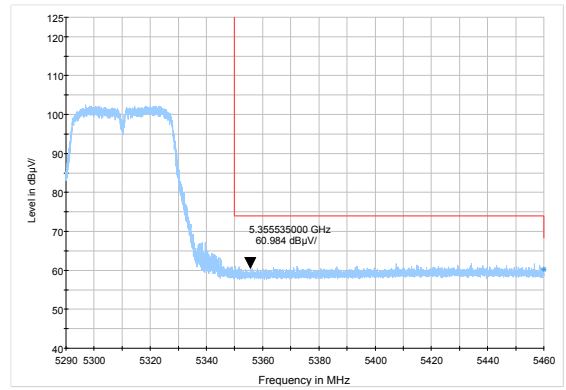

**802.11n HT40-Channel 54: Average**

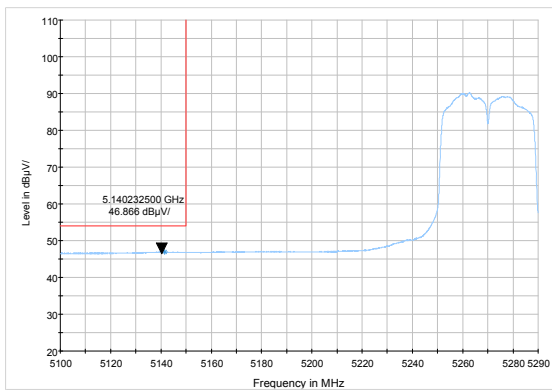

**802.11n HT40-Channel 62: Average**

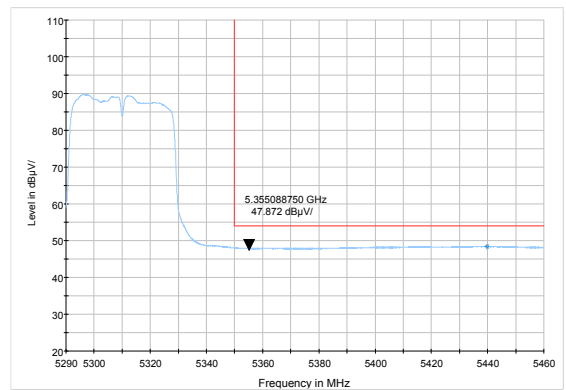



802.11ac HT20 -Channel 52: Peak

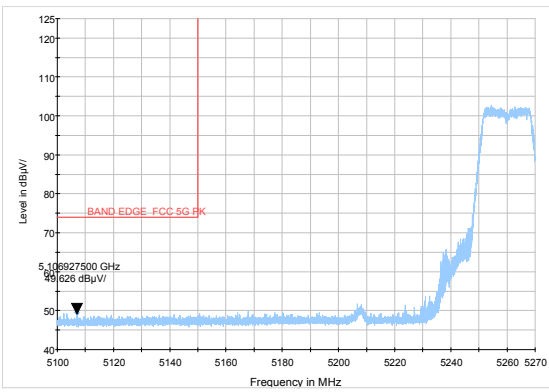

802.11ac HT20 -Channel 64: Peak

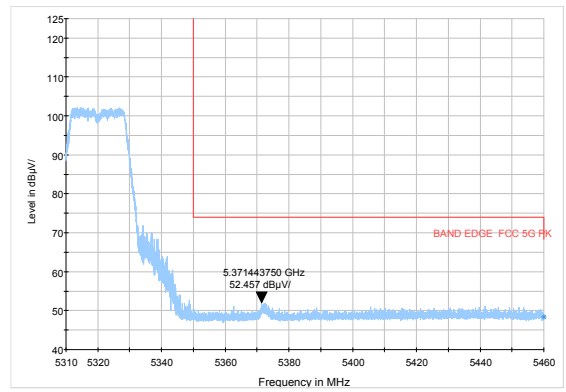

802.11ac HT20-Channel 52: Average

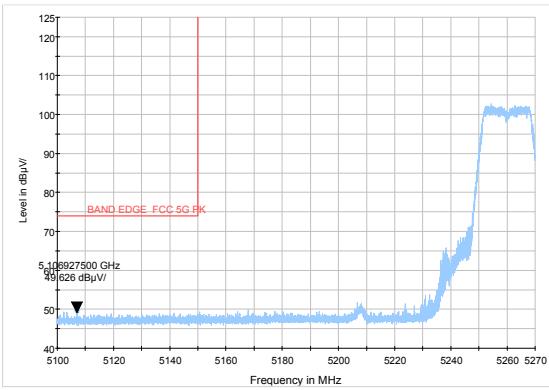

802.11ac HT20 -Channel 64: Average

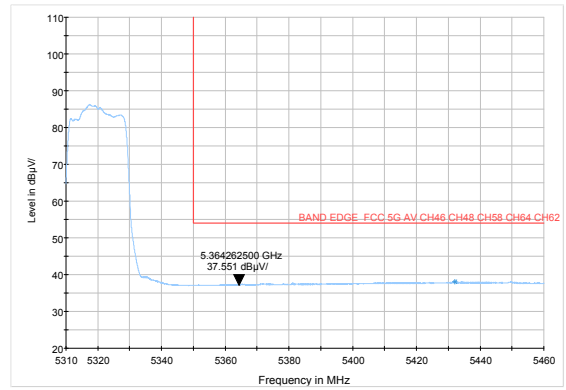



### 802.11ac HT40-Channel 54: Peak

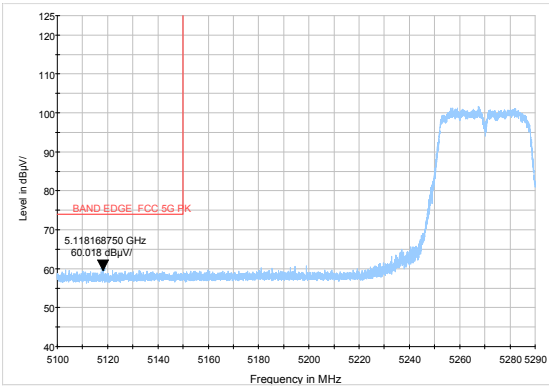

### 802.11ac HT40-Channel 62: Peak

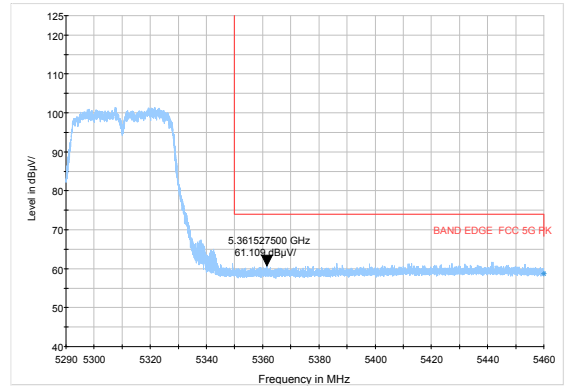

### 802.11ac HT40-Channel 54: Average

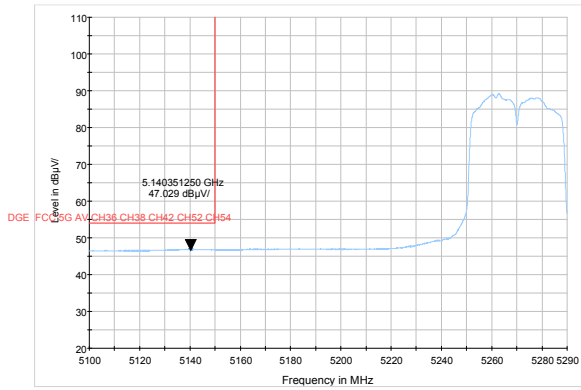

### 802.11ac HT40-Channel 62: Average

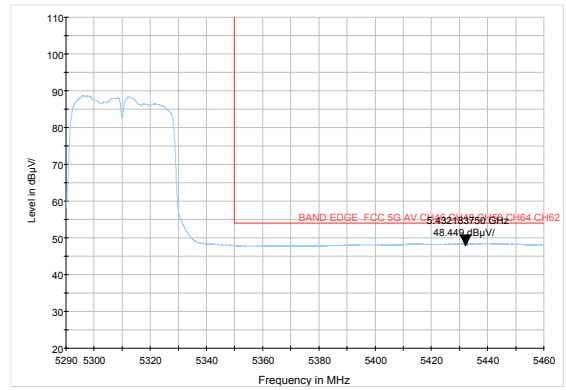

### 802.11ac HT80 -Channel 58: Peak

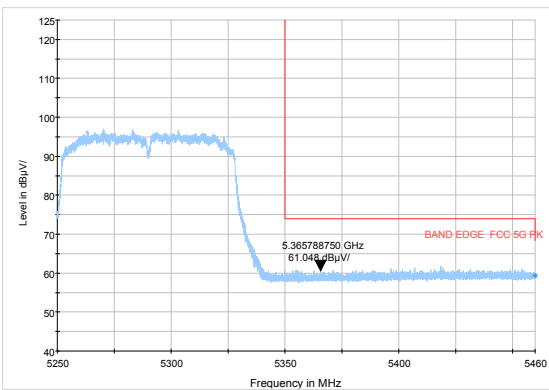

### 802.11ac HT80- Channel 58: Average

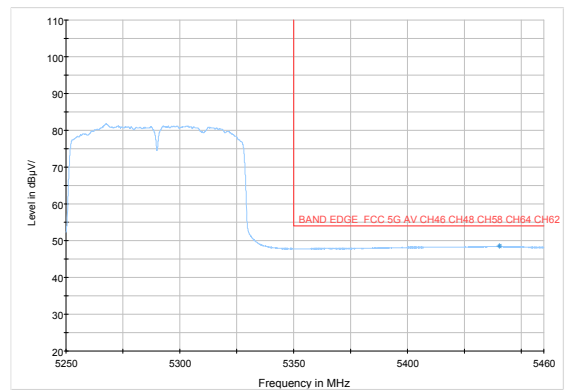



U-NII-2C

802.11a-Channel 100: Peak

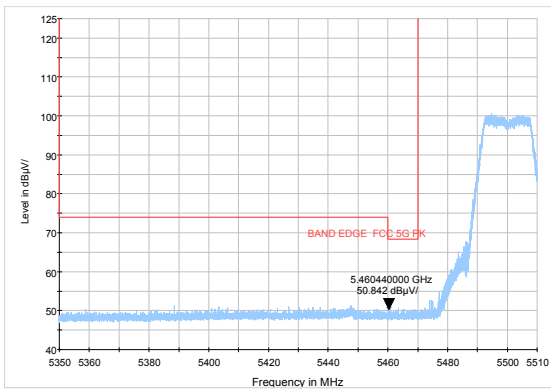

802.11a-Channel 140: Peak

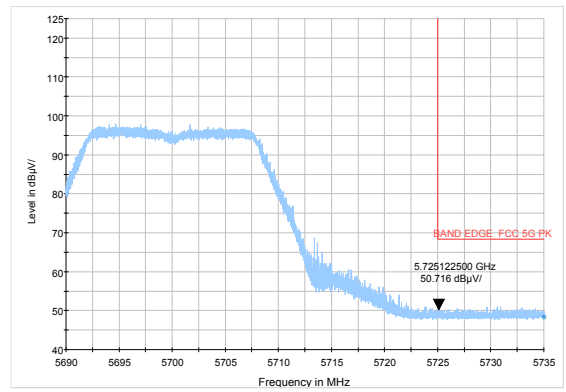

802.11a-Channel 100: Average

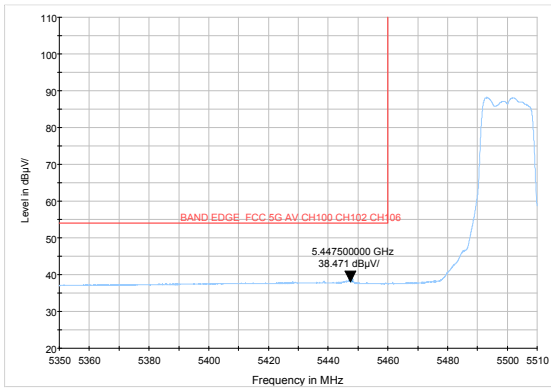



### 802.11n HT20-Channel 100: Peak

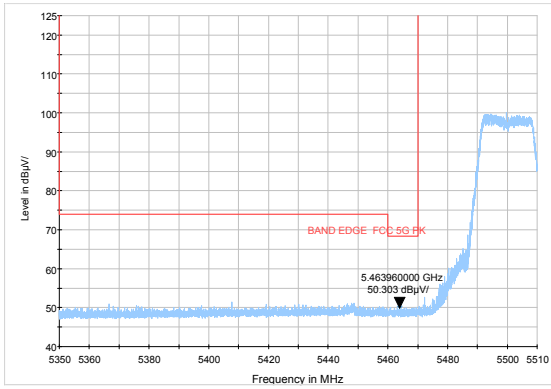

### 802.11n HT20-Channel 140: Peak

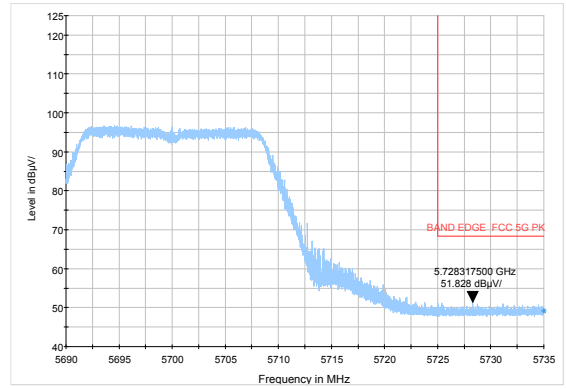

### 802.11n HT20-Channel 100: Average

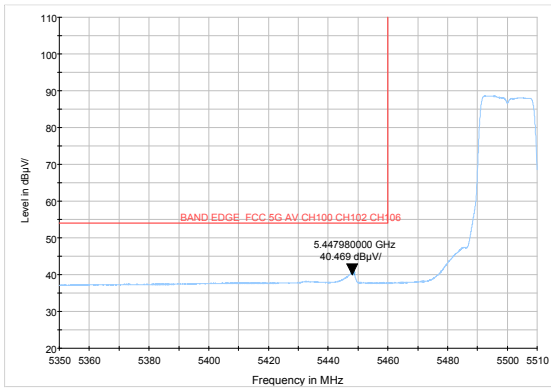



### 802.11n HT40-Channel 102: Peak

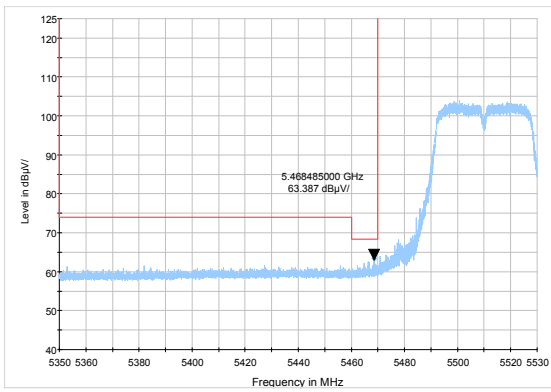

### 802.11n HT40-Channel 134: Peak

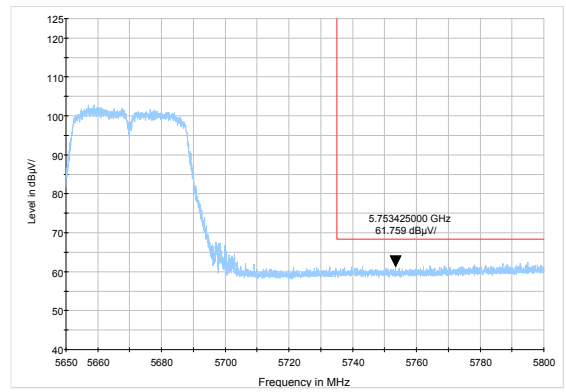

### 802.11n HT40-Channel 102: Average

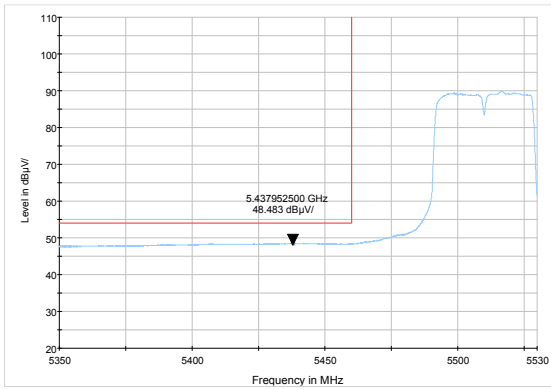



### 802.11ac HT20 -Channel 100: Peak

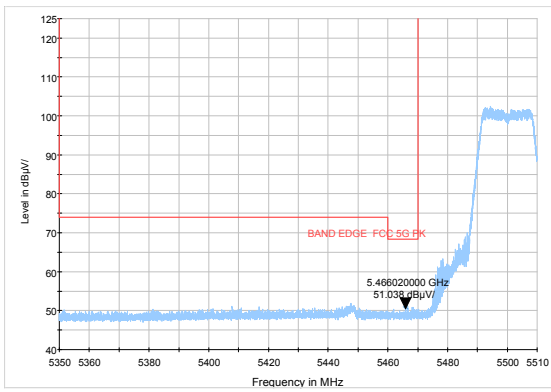

### 802.11ac HT20 -Channel 144: Peak

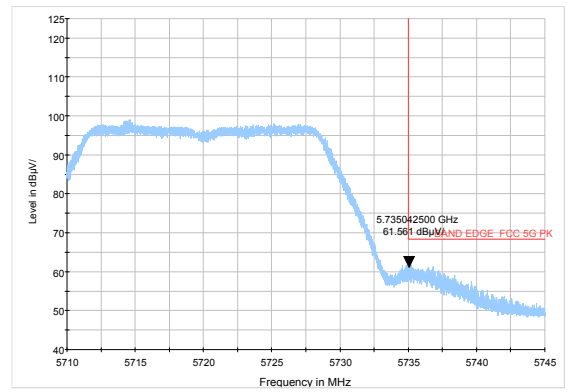

### 802.11ac HT20-Channel 100: Average

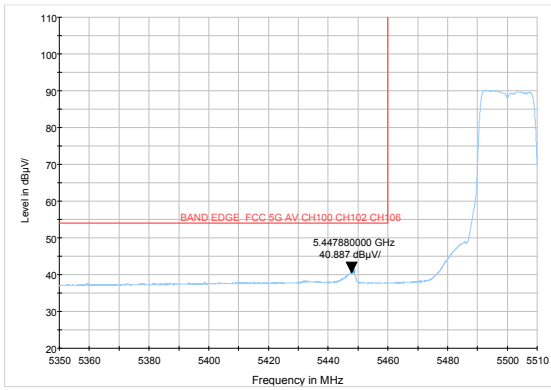





### 802.11ac HT40-Channel 102: Peak

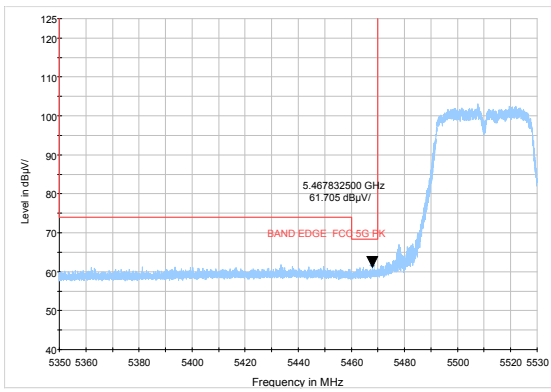

### 802.11ac HT40-Channel 142: Peak

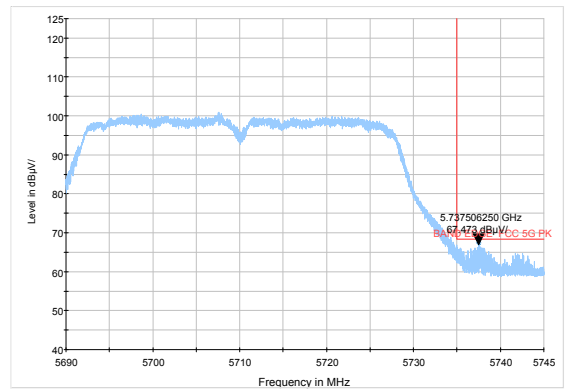

### 802.11ac HT40-Channel 102: Average

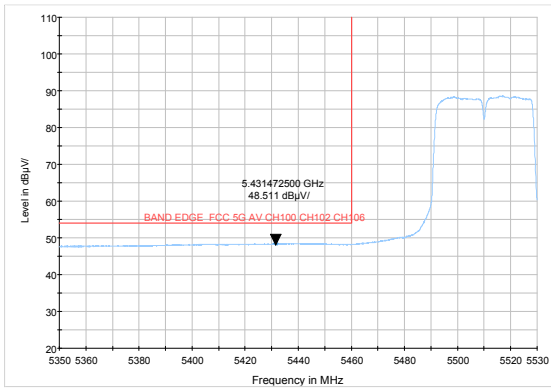

**802.11ac HT80 –Channel 106: Peak**

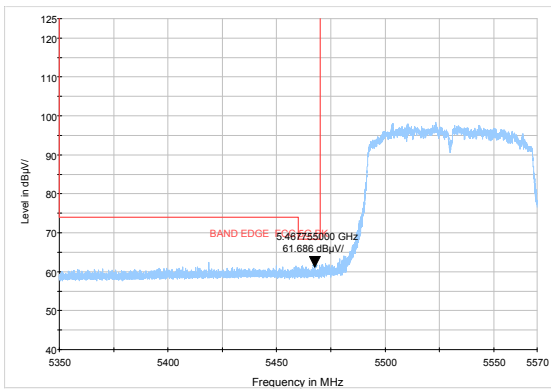

**802.11ac HT80 –Channel 138: Peak**

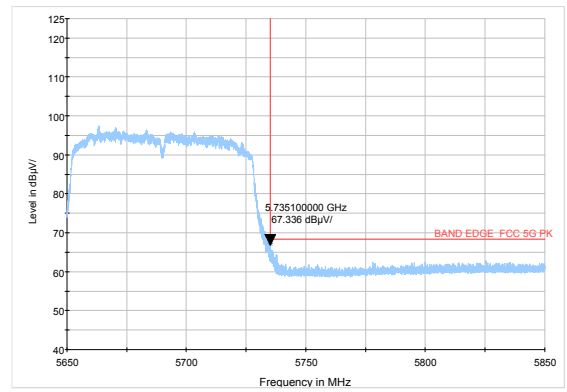

**802.11ac HT80- Channel 106: Average**

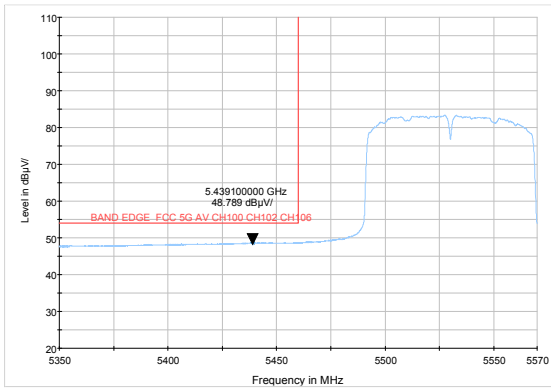



U-NII-3

802.11a-Channel 149: Peak

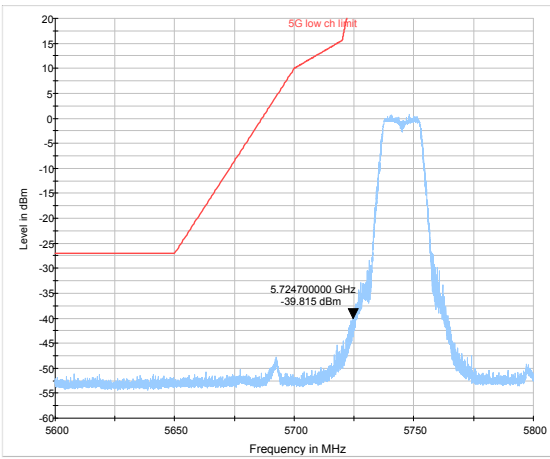

802.11a-Channel 165: Peak

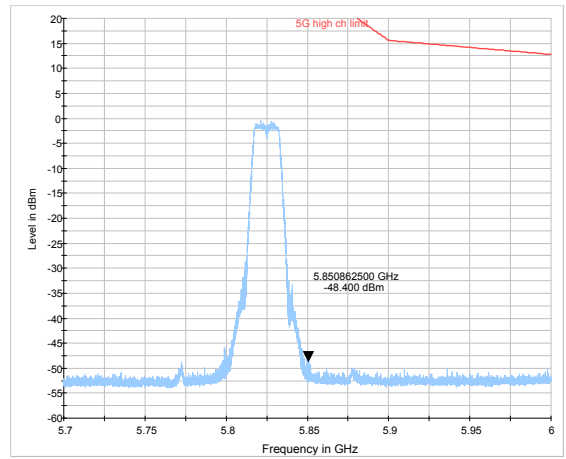

802.11n HT20-Channel 149: Peak

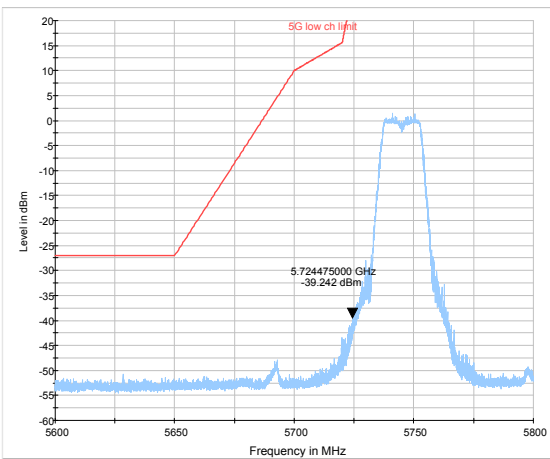

802.11n HT20-Channel 165: Peak

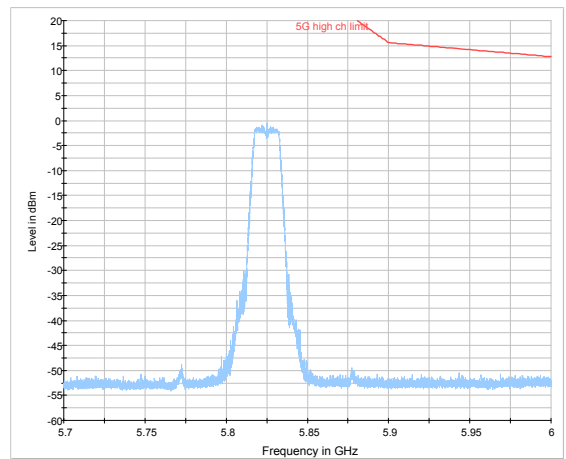

802.11n HT40-Channel 151: Peak

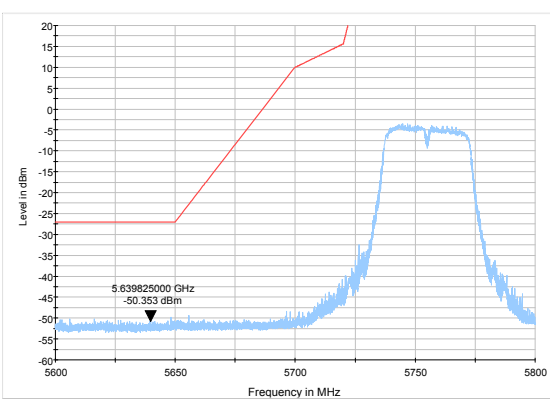

802.11n HT40-Channel 159: Peak

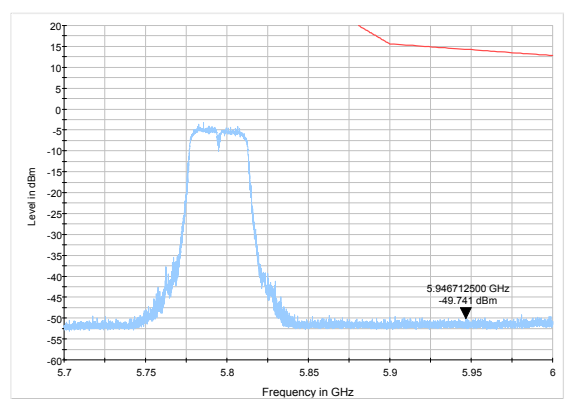



802.11ac HT20-Channel 149: Peak

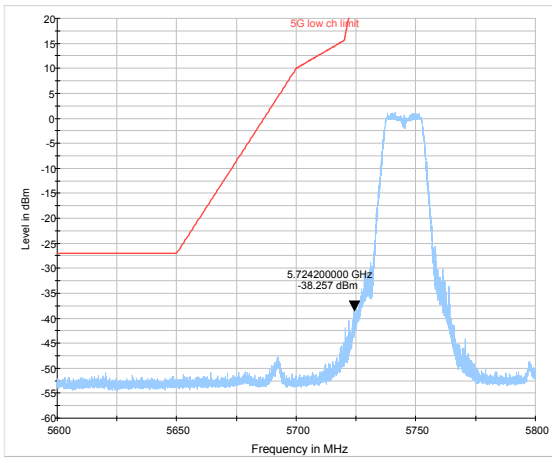

802.11ac HT20-Channel 165: Peak

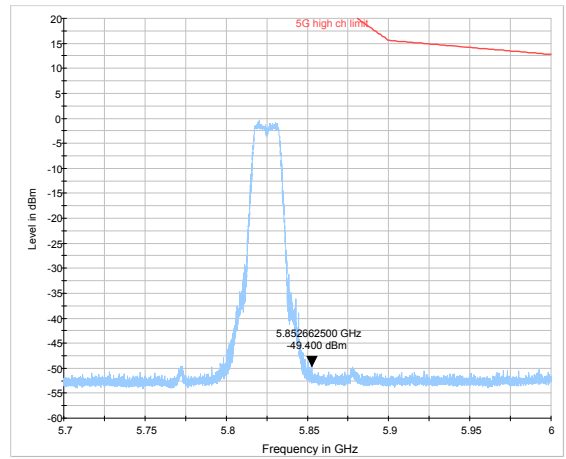

802.11ac HT40-Channel 151: Peak

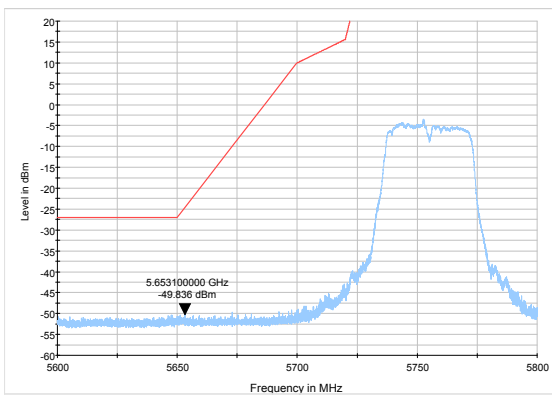

802.11ac HT40-Channel 159: Peak

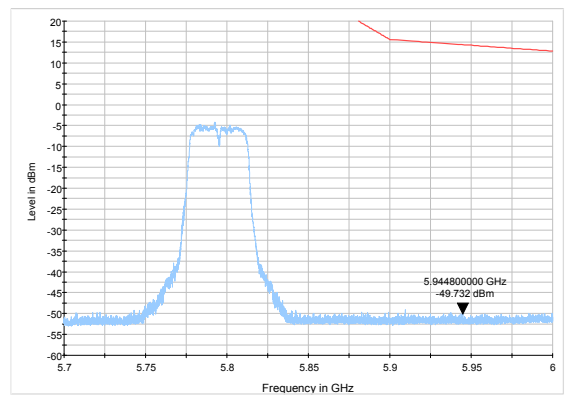

802.11ac HT80- Channel 155: Peak

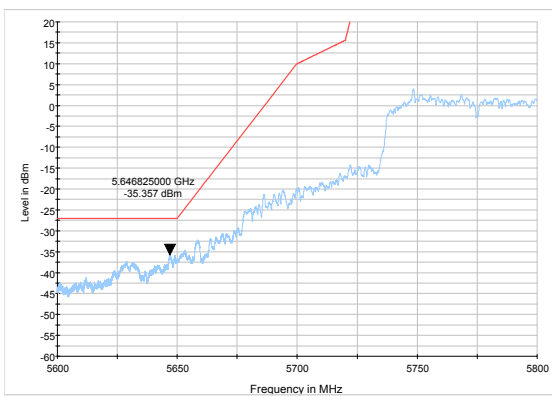

802.11ac HT80- Channel 155: Peak

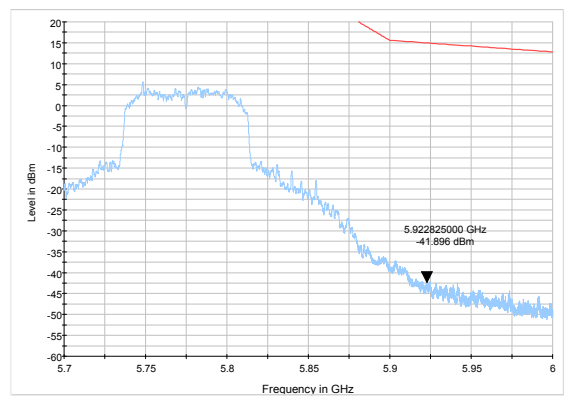



**Result of RE**

**Test result**

Sweep the whole frequency band through the range from 9kHz to the 10th harmonic of the carrier, and 9KHz-30MHz, the emissions more than 20 dB below the permissible value are not reported.

**802.11a CH36**

RE 30M-1GHz QP

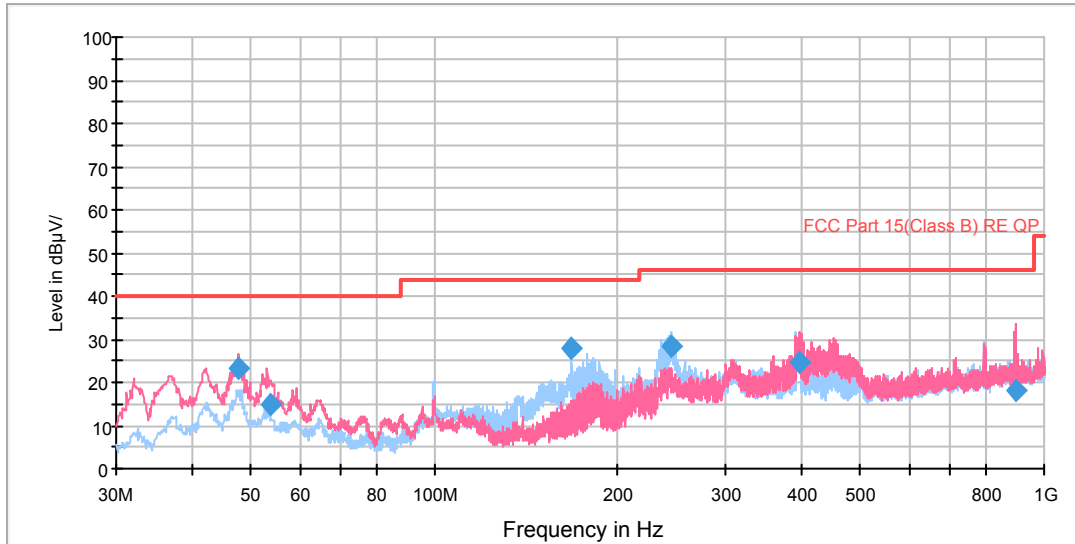

Radiates Emission from 30MHz to 1GHz

Frequency (MHz)	Quasi-Peak (dBuV/m)	Height (cm)	Polarization	Azimuth (deg)	Reading value (dBuV/m)	Correct Factor (dB)	Margin (dB)	Limit (dBuV/m)
47.662297	23.1	100.0	V	226.0	43.3	-20.2	16.9	40.0
53.751534	14.9	100.0	V	186.0	35.7	-20.8	25.1	40.0
168.002544	27.9	125.0	H	20.0	56.2	-28.3	15.6	43.5
244.278250	28.4	125.0	H	205.0	53.5	-25.1	17.6	46.0
397.386500	24.8	100.0	V	0.0	45.8	-21.0	21.2	46.0
897.588500	18.1	100.0	V	208.0	31.0	-12.9	27.9	46.0

- Remark: 1. Quasi-Peak = Reading value + Correction factor**  
**2. Correction Factor = Antenna factor+ Insertion loss(cable loss+amplifier gain)**  
**3. Margin = Limit – Quasi-Peak**

RE 1G-6GHz PK+AV Class B

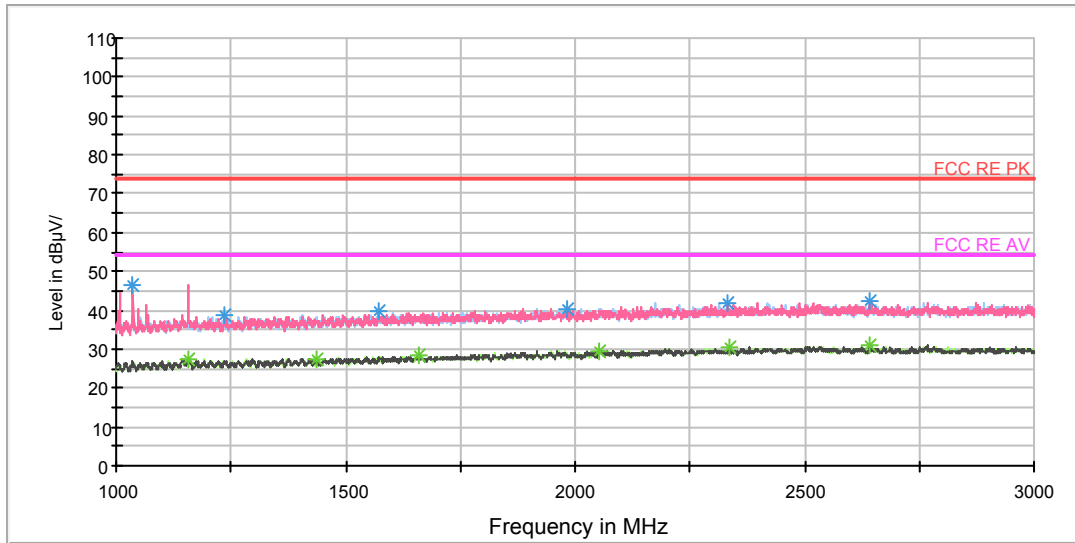

Radiates Emission from 1GHz to 3GHz

Frequency (MHz)	Peak (dBuV/m)	Height (cm)	Polarization	Azimuth (deg)	Reading value (dBuV/m)	Correct Factor (dB)	Margin (dB)	Limit (dBuV/m)
1037.000000	46.7	100.0	V	171.0	54.8	-8.1	27.3	74
1236.500000	38.7	100.0	V	275.0	46.1	-7.4	35.3	74
1573.000000	39.9	100.0	V	299.0	46.3	-6.4	34.1	74
1983.000000	40.4	100.0	V	7.0	45.3	-4.9	33.6	74
2333.500000	42.0	100.0	V	2.0	45.5	-3.5	32.0	74
2643.000000	42.4	100.0	V	25.0	45.1	-2.7	31.6	74

Remark: 1. Correction Factor = Antenna factor+ Insertion loss (cable loss + amplifier gain)

Frequency (MHz)	Average (dBuV/m)	Height (cm)	Polarization	Azimuth (deg)	Reading value (dBuV/m)	Correct Factor (dB)	Margin (dB)	Limit (dBuV/m)
1156.000000	27.5	100.0	V	25.0	35.2	-7.7	26.5	54
1435.000000	27.6	100.0	H	358.0	34.4	-6.8	26.4	54
1657.500000	28.3	100.0	H	105.0	34.3	-6.0	25.7	54
2053.500000	29.4	100.0	H	358.0	34.0	-4.6	24.6	54
2335.500000	30.4	100.0	H	350.0	33.8	-3.4	23.6	54
2642.500000	30.8	100.0	V	2.0	33.5	-2.7	23.2	54

Remark: 1. Correction Factor = Antenna factor+ Insertion loss (cable loss + amplifier gain)

RE 3-18GHz PK+AV

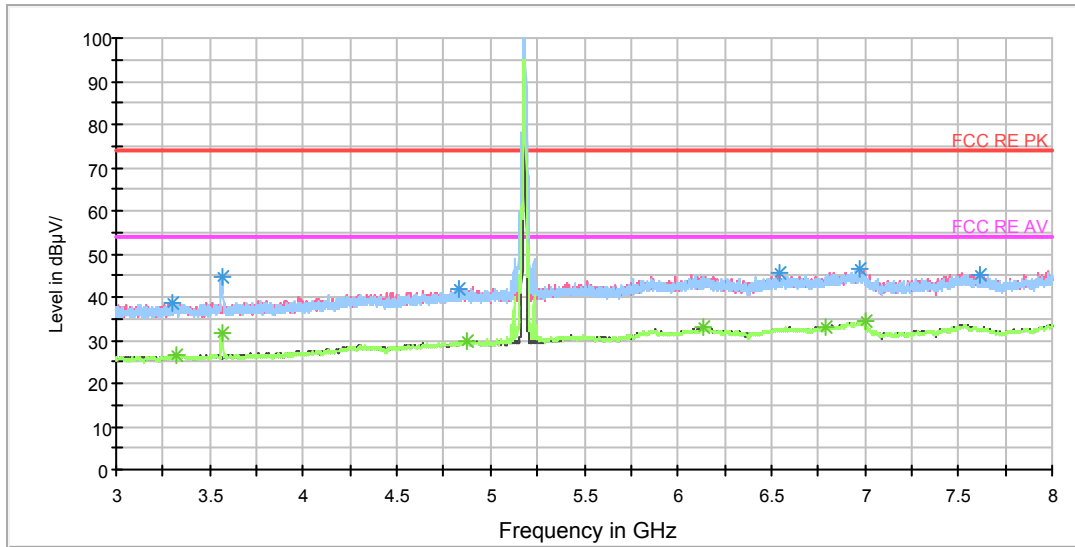

Note: The signal beyond the limit is carrier.  
Radiates Emission from 3GHz to 8Hz

Frequency (MHz)	Peak (dBuV/m)	Height (cm)	Polarization	Azimuth (deg)	Reading value (dBuV/m)	Correct Factor (dB)	Margin (dB)	Limit (dBuV/m)
3300.625000	38.8	100.0	H	260.0	41.0	-2.2	35.2	74
3563.125000	44.5	100.0	H	31.0	46.6	-2.1	29.5	74
4832.500000	42.0	100.0	V	277.0	40.5	1.5	32.0	74
6545.625000	45.8	100.0	V	0.0	40.3	5.5	28.2	74
6969.375000	46.4	100.0	V	151.0	40.1	6.3	27.6	74
7616.250000	45.2	100.0	V	0.0	38.4	6.8	28.8	74

Remark: 1. Correction Factor = Antenna factor+ Insertion loss (cable loss + amplifier gain)

Frequency (MHz)	Average (dBuV/m)	Height (cm)	Polarization	Azimuth (deg)	Reading value (dBuV/m)	Correct Factor (dB)	Margin (dB)	Limit (dBuV/m)
3323.125000	26.6	100.0	V	227.0	28.7	-2.1	27.4	54
3563.125000	31.6	100.0	H	31.0	33.7	-2.1	22.4	54
4877.500000	29.8	100.0	H	31.0	28.0	1.8	24.2	54
6141.875000	32.8	100.0	V	302.0	27.4	5.4	21.2	54
6790.625000	33.1	100.0	V	277.0	27.4	5.7	20.9	54
6999.375000	34.3	100.0	H	0.0	27.8	6.5	19.7	54

Remark: 1. Correction Factor = Antenna factor+ Insertion loss (cable loss + amplifier gain)

RE 3-18GHz PK+AV

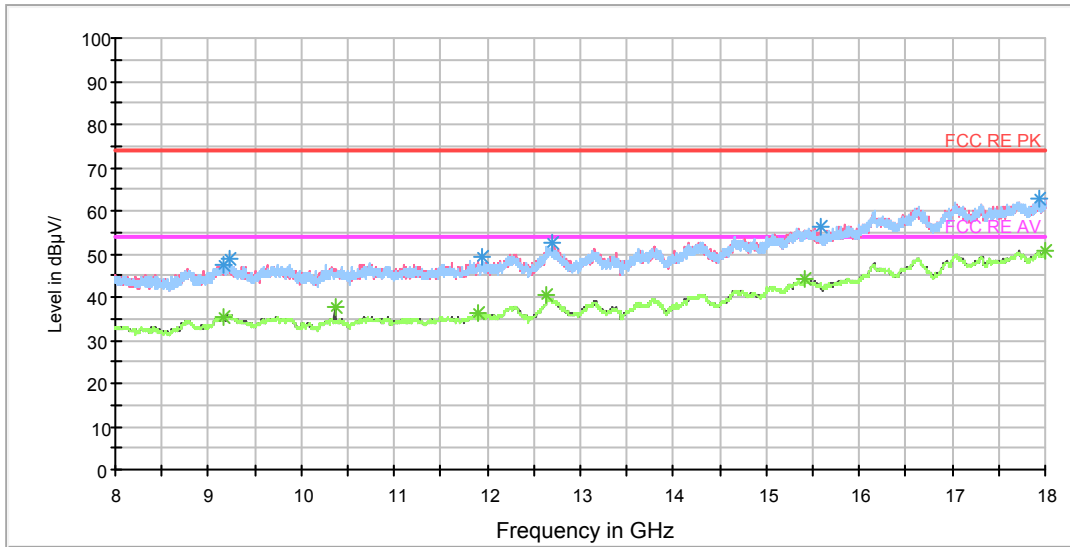

Radiates Emission from 8Hz to 18GHz

Frequency (MHz)	Peak (dBuV/m)	Height (cm)	Polarization	Azimuth (deg)	Reading value (dBuV/m)	Correct Factor (dB)	Margin (dB)	Limit (dBuV/m)
9153.750000	47.4	200.0	V	114.0	37.2	10.2	26.6	74
9230.000000	49.0	200.0	H	80.0	39.1	9.9	25.0	74
11942.500000	49.1	200.0	H	168.0	37.3	11.8	24.9	74
12698.750000	52.3	200.0	V	168.0	38.2	14.1	21.7	74
15578.750000	56.2	100.0	V	271.0	36.9	19.3	17.8	74
17932.500000	62.9	200.0	V	0.0	37.6	25.3	11.1	74

Remark: 1. Correction Factor = Antenna factor+ Insertion loss (cable loss + amplifier gain)

Frequency (MHz)	Average (dBuV/m)	Height (cm)	Polarization	Azimuth (deg)	Reading value (dBuV/m)	Correct Factor (dB)	Margin (dB)	Limit (dBuV/m)
9157.500000	35.5	100.0	V	0.0	25.2	10.3	18.5	54
10360.000000	37.4	100.0	V	108.0	27.6	9.8	16.6	54
11900.000000	36.5	200.0	V	7.0	24.2	12.3	17.5	54
12641.250000	40.3	200.0	H	0.0	25.8	14.5	13.7	54
15417.500000	44.0	200.0	H	355.0	24.7	19.3	10.0	54
17998.750000	50.6	200.0	V	0.0	25.2	25.4	3.4	54

Remark: 1. Correction Factor = Antenna factor+ Insertion loss (cable loss + amplifier gain)



RE 18-26.5GHz PK+AV

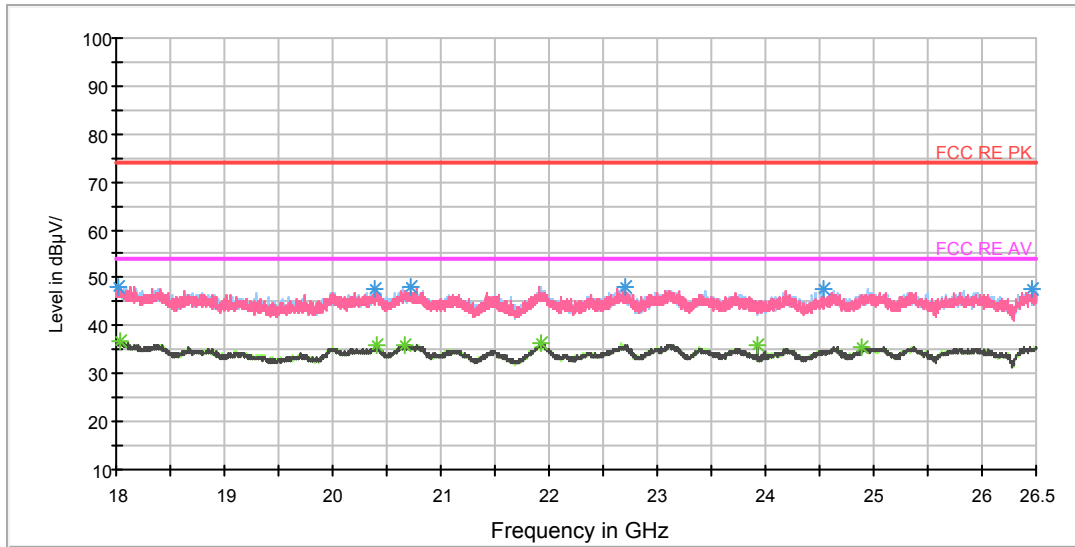

Radiates Emission from 18GHz to 26.5GHz

Frequency (MHz)	Peak (dBuV/m)	Polarization	Azimuth (deg)	Reading value (dBuV/m)	Correct Factor (dB)	Margin (dB)	Limit (dBuV/m)
18014.875000	48.3	H	266.0	50.2	-1.9	25.7	74
20398.062500	47.7	H	0.0	53.8	-6.1	26.3	74
20727.437500	48.1	H	0.0	54.9	-6.8	25.9	74
22696.250000	48.3	H	266.0	54.9	-6.6	25.7	74
24534.375000	47.6	H	0.0	53.6	-6.0	26.4	74
26456.437500	47.6	V	119.0	53.0	-5.4	26.4	74

Remark: 1. Correction Factor = Antenna factor+ Insertion loss (cable loss + amplifier gain)

Frequency (MHz)	Average (dBuV/m)	Polarization	Azimuth (deg)	Reading value (dBuV/m)	Correct Factor (dB)	Margin (dB)	Limit (dBuV/m)
18028.687500	36.7	V	0.0	38.6	-1.9	17.3	54
20404.437500	36.0	V	141.0	42.1	-6.1	18.0	54
20662.625000	36.1	H	286.0	42.7	-6.6	17.9	54
21921.687500	36.4	H	212.0	44.4	-8.0	17.6	54
23929.812500	35.9	V	205.0	41.8	-5.9	18.1	54
24892.437500	35.7	H	0.0	41.6	-5.9	18.3	54

Remark: 1. Correction Factor = Antenna factor+ Insertion loss (cable loss + amplifier gain)

RE 26.5-40GHz PK+AV

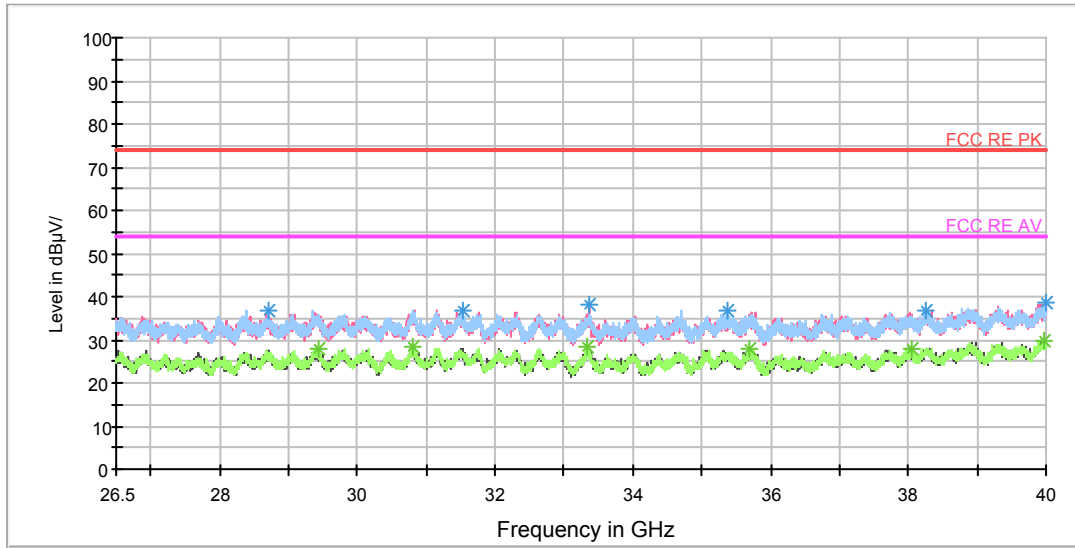

Radiates Emission from 26.5GHz to 40GHz

Frequency (MHz)	Peak (dBuV/m)	Polarization	Azimuth (deg)	Reading value (dBuV/m)	Correct Factor (dB)	Margin (dB)	Limit (dBuV/m)
28719.062500	36.8	H	39.0	38.1	-1.3	37.2	74
31525.375000	36.7	H	206.0	37.2	-0.5	37.3	74
33354.625000	38.0	V	264.0	39.0	-1.0	36.0	74
35361.062500	36.7	H	153.0	37.2	-0.5	37.3	74
38241.625000	36.9	V	349.0	35.0	1.9	37.1	74
39998.312500	38.4	V	79.0	36.1	2.3	35.6	74

Remark: 1. Correction Factor = Antenna factor+ Insertion loss (cable loss + amplifier gain)

Frequency (MHz)	Average (dBuV/m)	Polarization	Azimuth (deg)	Reading value (dBuV/m)	Correct Factor (dB)	Margin (dB)	Limit (dBuV/m)
29429.500000	28.0	H	110.0	28.9	-0.9	26.0	54
30814.937500	28.4	H	0.0	28.8	-0.4	25.6	54
33346.187500	28.4	V	349.0	29.4	-1.0	25.6	54
35686.750000	27.7	H	238.0	28.1	-0.4	26.3	54
38050.937500	27.9	V	138.0	26.3	1.6	26.1	54
39966.250000	29.9	H	206.0	27.6	2.3	24.1	54

Remark: 1. Correction Factor = Antenna factor+ Insertion loss (cable loss + amplifier gain)



802.11a CH40

RE 30M-1GHz QP

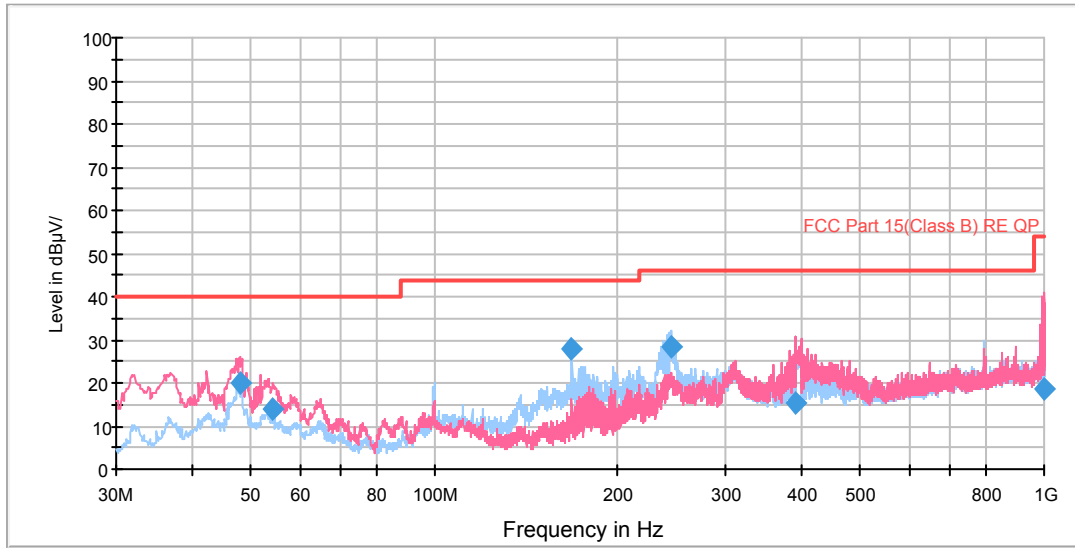

Radiates Emission from 30MHz to 1GHz

Frequency (MHz)	Quasi-Peak (dBuV/m)	Height (cm)	Polarization	Azimuth (deg)	Reading value (dBuV/m)	Correct Factor (dB)	Margin (dB)	Limit (dBuV/m)
47.943310	20.0	125.0	V	237.0	40.2	-20.2	20.0	40.0
54.114375	13.9	100.0	V	196.0	34.8	-20.9	29.6	43.5
168.002544	28.1	125.0	H	15.0	56.4	-28.3	15.4	43.5
244.319000	28.2	125.0	H	207.0	53.3	-25.1	17.8	46.0
391.105000	15.5	100.0	H	328.0	36.8	-21.3	30.5	46.0
998.094500	18.8	120.0	V	7.0	30.8	-12.0	27.2	46.0

- Remark: 1. Quasi-Peak = Reading value + Correction factor  
 2. Correction Factor = Antenna factor+ Insertion loss(cable loss+amplifier gain)  
 3. Margin = Limit – Quasi-Peak

RE 1G-6GHz PK+AV Class B

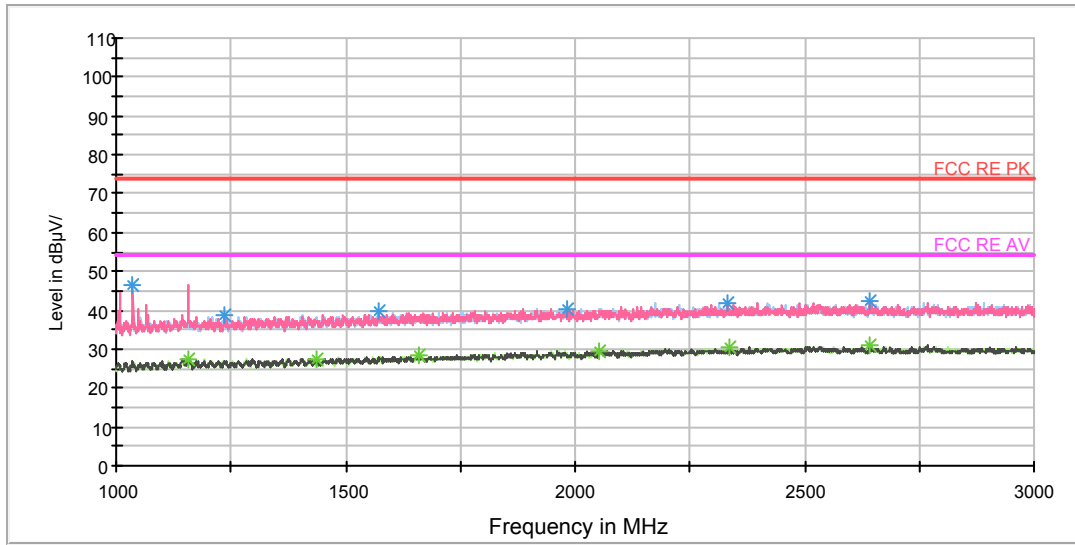

Radiates Emission from 1GHz to 3GHz

Frequency (MHz)	Peak (dBuV/m)	Height (cm)	Polarization	Azimuth (deg)	Reading value (dBuV/m)	Correct Factor (dB)	Margin (dB)	Limit (dBuV/m)
1037.000000	46.7	100.0	V	171.0	54.8	-8.1	27.3	74
1236.500000	38.7	100.0	V	275.0	46.1	-7.4	35.3	74
1573.000000	39.9	100.0	V	299.0	46.3	-6.4	34.1	74
1983.000000	40.4	100.0	V	7.0	45.3	-4.9	33.6	74
2333.500000	42.0	100.0	V	2.0	45.5	-3.5	32.0	74
2643.000000	42.4	100.0	V	25.0	45.1	-2.7	31.6	74

Remark: 1. Correction Factor = Antenna factor+ Insertion loss (cable loss + amplifier gain)

Frequency (MHz)	Average (dBuV/m)	Height (cm)	Polarization	Azimuth (deg)	Reading value (dBuV/m)	Correct Factor (dB)	Margin (dB)	Limit (dBuV/m)
1156.000000	27.5	100.0	V	25.0	35.2	-7.7	26.5	54
1435.000000	27.6	100.0	H	358.0	34.4	-6.8	26.4	54
1657.500000	28.3	100.0	H	105.0	34.3	-6.0	25.7	54
2053.500000	29.4	100.0	H	358.0	34.0	-4.6	24.6	54
2335.500000	30.4	100.0	H	350.0	33.8	-3.4	23.6	54
2642.500000	30.8	100.0	V	2.0	33.5	-2.7	23.2	54

Remark: 1. Correction Factor = Antenna factor+ Insertion loss (cable loss + amplifier gain)

RE 3-18GHz PK+AV

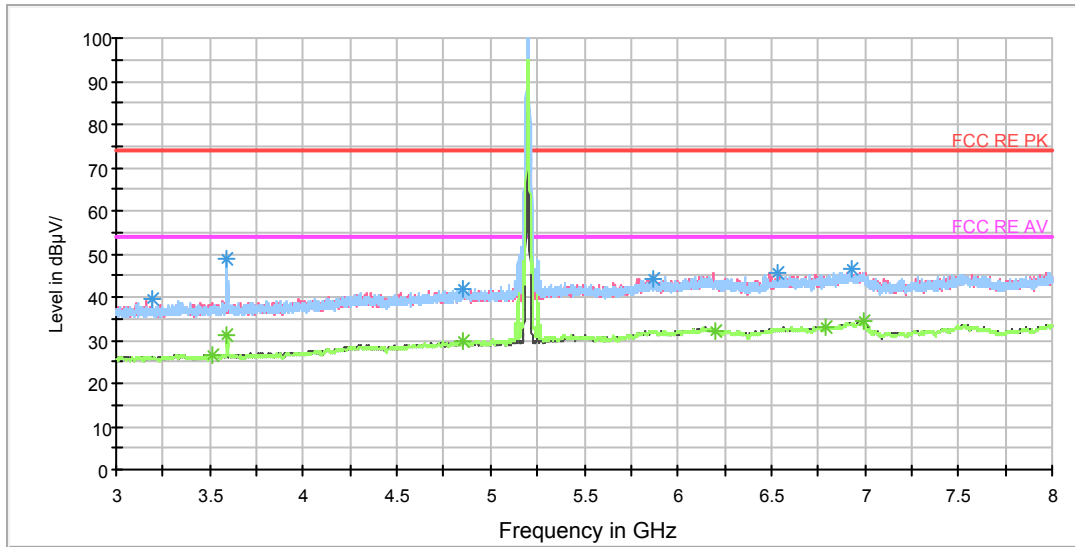

Note: The signal beyond the limit is carrier.  
Radiates Emission from 3GHz to 8Hz

Frequency (MHz)	Peak (dBuV/m)	Height (cm)	Polarization	Azimuth (deg)	Reading value (dBuV/m)	Correct Factor (dB)	Margin (dB)	Limit (dBuV/m)
3193.125000	39.5	100.0	H	0.0	42.4	-2.9	34.5	74
3590.625000	48.8	100.0	H	0.0	51.1	-2.3	25.2	74
4854.375000	41.8	100.0	H	33.0	40.2	1.6	32.2	74
5874.375000	44.0	100.0	H	82.0	39.1	4.9	30.0	74
6536.875000	45.7	100.0	H	0.0	40.3	5.4	28.3	74
6925.625000	46.4	100.0	H	234.0	40.2	6.2	27.6	74

Remark: 1. Correction Factor = Antenna factor+ Insertion loss (cable loss + amplifier gain)

Frequency (MHz)	Average (dBuV/m)	Height (cm)	Polarization	Azimuth (deg)	Reading value (dBuV/m)	Correct Factor (dB)	Margin (dB)	Limit (dBuV/m)
3510.000000	26.6	100.0	V	298.0	28.6	-2.0	27.4	54
3593.125000	31.4	100.0	H	0.0	33.7	-2.3	22.6	54
4854.375000	29.8	100.0	H	33.0	28.2	1.6	24.2	54
6198.750000	32.2	100.0	V	173.0	26.8	5.4	21.8	54
6792.500000	33.1	100.0	V	347.0	27.4	5.7	20.9	54
6993.750000	34.3	100.0	H	0.0	27.8	6.5	19.7	54

Remark: 1. Correction Factor = Antenna factor+ Insertion loss (cable loss + amplifier gain)

RE 3-18GHz PK+AV

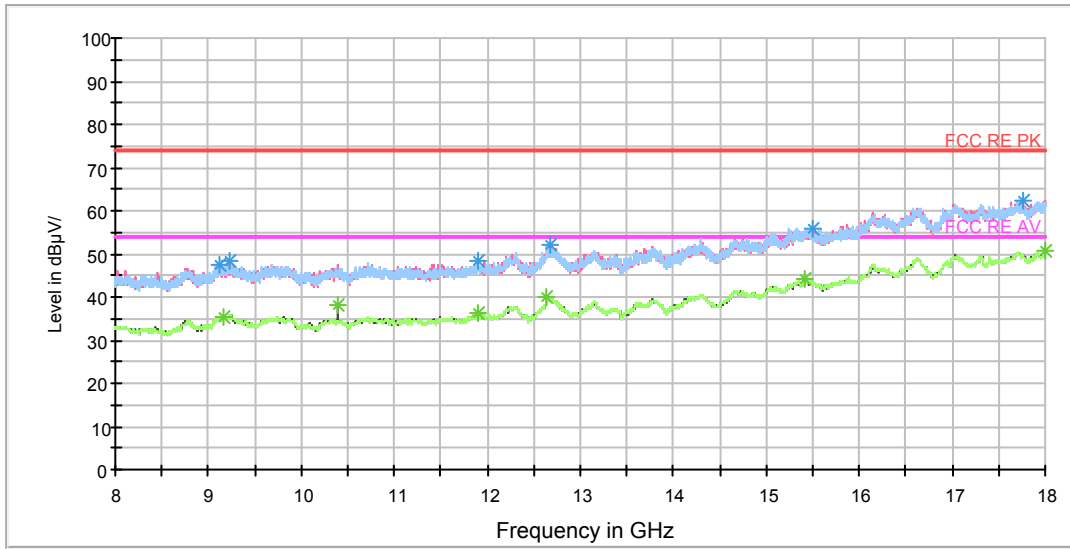

Radiates Emission from 8Hz to 18GHz

Frequency (MHz)	Peak (dBuV/m)	Height (cm)	Polarization	Azimuth (deg)	Reading value (dBuV/m)	Correct Factor (dB)	Margin (dB)	Limit (dBuV/m)
9125.000000	47.3	200.0	H	323.0	37.3	10.0	26.7	74
9235.000000	48.4	100.0	V	297.0	38.5	9.9	25.6	74
11895.000000	48.3	100.0	V	0.0	36.2	12.1	25.7	74
12666.250000	52.1	200.0	V	10.0	38.2	13.9	21.9	74
15493.750000	55.9	200.0	H	323.0	36.4	19.5	18.1	74
17766.250000	62.4	200.0	V	37.0	38.2	24.2	11.6	74

Remark: 1. Correction Factor = Antenna factor+ Insertion loss (cable loss + amplifier gain)

Frequency (MHz)	Average (dBuV/m)	Height (cm)	Polarization	Azimuth (deg)	Reading value (dBuV/m)	Correct Factor (dB)	Margin (dB)	Limit (dBuV/m)
9153.750000	35.5	100.0	H	0.0	25.3	10.2	18.5	54
10400.000000	38.0	100.0	V	81.0	28.6	9.4	16.0	54
11901.250000	36.2	100.0	H	117.0	23.9	12.3	17.8	54
12640.000000	40.2	200.0	V	226.0	25.6	14.6	13.8	54
15421.250000	44.0	200.0	V	226.0	24.6	19.4	10.0	54
18000.000000	50.5	100.0	V	243.0	25.0	25.5	3.5	54

Remark: 1. Correction Factor = Antenna factor+ Insertion loss (cable loss + amplifier gain)

RE 18-26.5GHz PK+AV

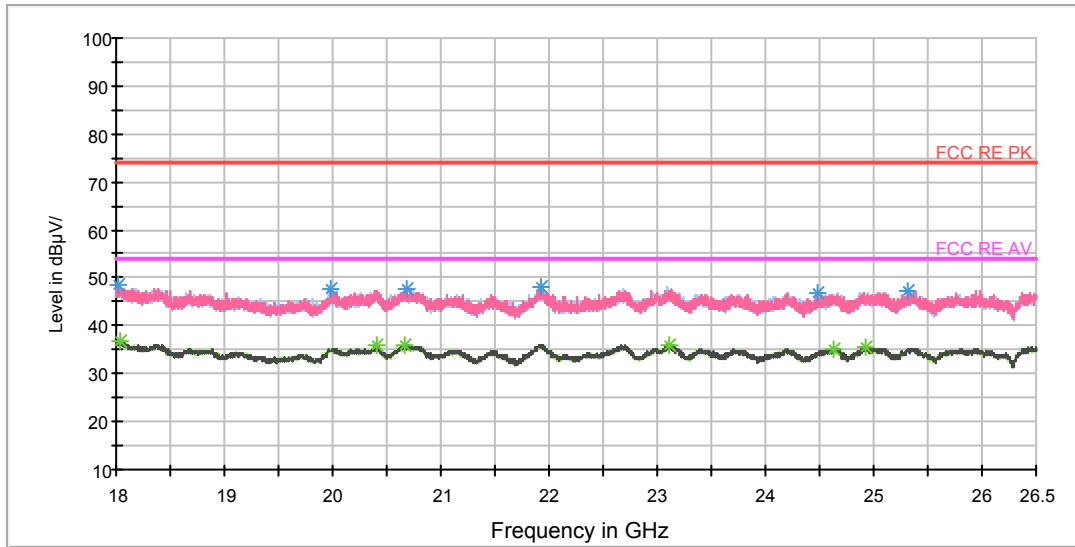

Radiates Emission from 18GHz to 26.5GHz

Frequency (MHz)	Peak (dBuV/m)	Polarization	Azimuth (deg)	Reading value (dBuV/m)	Correct Factor (dB)	Margin (dB)	Limit (dBuV/m)
18024.437500	48.4	V	0.0	50.3	-1.9	25.6	74
19979.437500	47.6	V	47.0	53.3	-5.7	26.4	74
20687.062500	47.5	V	184.0	54.2	-6.7	26.5	74
21924.875000	48.2	V	5.0	56.2	-8.0	25.8	74
24485.500000	47.0	V	142.0	53.0	-6.0	27.0	74
25313.187500	47.3	H	69.0	53.1	-5.8	26.7	74

Remark: 1. Correction Factor = Antenna factor+ Insertion loss (cable loss + amplifier gain)

Frequency (MHz)	Average (dBuV/m)	Polarization	Azimuth (deg)	Reading value (dBuV/m)	Correct Factor (dB)	Margin (dB)	Limit (dBuV/m)
18029.750000	36.9	H	125.0	38.8	-1.9	17.1	54
20409.750000	36.0	H	125.0	42.1	-6.1	18.0	54
20669.000000	35.9	H	243.0	42.5	-6.6	18.1	54
23108.500000	36.1	H	0.0	42.2	-6.1	17.9	54
24637.437500	35.3	V	0.0	41.3	-6.0	18.7	54
24929.625000	35.6	H	136.0	41.5	-5.9	18.4	54

Remark: 1. Correction Factor = Antenna factor+ Insertion loss (cable loss + amplifier gain)

RE 26.5-40GHz PK+AV



Radiates Emission from 26.5GHz to 40GHz

Frequency (MHz)	Peak (dBuV/m)	Polarization	Azimuth (deg)	Reading value (dBuV/m)	Correct Factor (dB)	Margin (dB)	Limit (dBuV/m)
27973.187500	35.6	V	329.0	37.3	-1.7	38.4	74
29414.312500	36.7	V	113.0	37.6	-0.9	37.3	74
31704.250000	36.5	H	0.0	37.0	-0.5	37.5	74
33342.812500	36.5	H	86.0	37.5	-1.0	37.5	74
35062.375000	36.0	V	29.0	36.7	-0.7	38.0	74
39880.187500	38.6	V	0.0	36.2	2.4	35.4	74

Remark: 1. Correction Factor = Antenna factor+ Insertion loss (cable loss + amplifier gain)

Frequency (MHz)	Average (dBuV/m)	Polarization	Azimuth (deg)	Reading value (dBuV/m)	Correct Factor (dB)	Margin (dB)	Limit (dBuV/m)
26602.937500	27.6	V	93.0	28.0	-0.4	26.4	54
29407.562500	27.7	H	152.0	28.6	-0.9	26.3	54
31171.000000	28.1	H	0.0	28.5	-0.4	25.9	54
33364.750000	28.3	H	248.0	29.3	-1.0	25.7	54
35713.750000	28.1	H	78.0	28.4	-0.3	25.9	54
38931.812500	30.1	H	209.0	27.2	2.9	23.9	54

Remark: 1. Correction Factor = Antenna factor+ Insertion loss (cable loss + amplifier gain)





802.11a CH48

RE 30M-1GHz QP

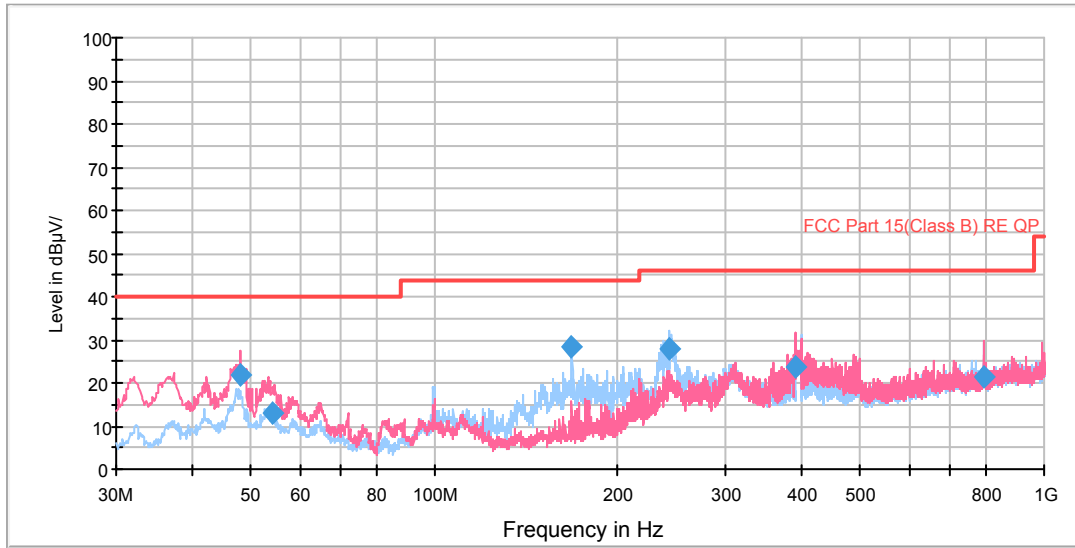

Radiates Emission from 0.03MHz to 1GHz

Frequency (MHz)	Quasi-Peak (dBuV/m)	Height (cm)	Polarization	Azimuth (deg)	Reading value (dBuV/m)	Correct Factor (dB)	Margin (dB)	Limit (dBuV/m)
47.985138	21.7	100.0	V	222.0	41.9	-20.2	18.3	40.0
54.356269	13.0	120.0	V	192.0	34.0	-21.0	27.0	40.0
168.002544	28.3	125.0	H	16.0	56.6	-28.3	15.2	43.5
242.424000	27.8	125.0	H	216.0	52.9	-25.1	18.2	46.0
390.705000	23.6	125.0	V	3.0	44.9	-21.3	22.4	46.0
799.734000	21.2	100.0	V	73.0	36.0	-14.8	24.8	46.0

- Remark: 1. Quasi-Peak = Reading value + Correction factor  
 2. Correction Factor = Antenna factor+ Insertion loss(cable loss+amplifier gain)  
 3. Margin = Limit – Quasi-Peak

RE 1G-6GHz PK+AV Class B

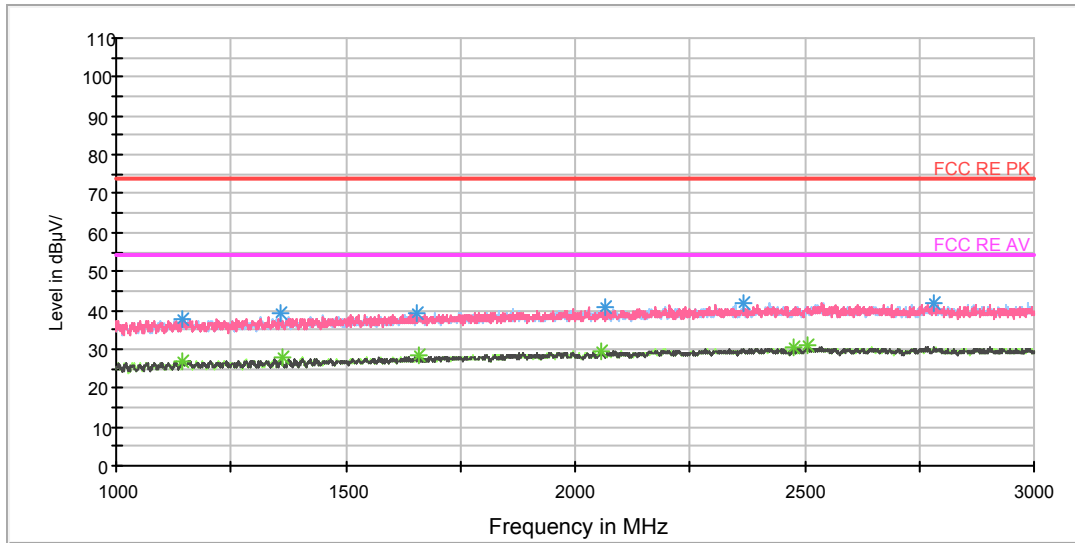

Radiates Emission from 1GHz to 3GHz

Frequency (MHz)	Peak (dBuV/m)	Height (cm)	Polarization	Azimuth (deg)	Reading value (dBuV/m)	Correct Factor (dB)	Margin (dB)	Limit (dBuV/m)
1142.000000	37.8	100.0	V	6.0	45.5	-7.7	36.2	74
1360.000000	39.0	100.0	H	173.0	46.1	-7.1	35.0	74
1654.500000	39.3	100.0	V	122.0	45.4	-6.1	34.7	74
2067.000000	41.0	100.0	V	6.0	45.5	-4.5	33.0	74
2367.000000	41.8	100.0	H	311.0	45.1	-3.3	32.2	74
2783.500000	41.9	100.0	H	0.0	44.5	-2.6	32.1	74

Remark: 1. Correction Factor = Antenna factor+ Insertion loss (cable loss + amplifier gain)

Frequency (MHz)	Average (dBuV/m)	Height (cm)	Polarization	Azimuth (deg)	Reading value (dBuV/m)	Correct Factor (dB)	Margin (dB)	Limit (dBuV/m)
1143.500000	27.1	100.0	V	0.0	34.8	-7.7	26.9	54
1360.500000	27.7	100.0	H	0.0	34.8	-7.1	26.3	54
1657.500000	28.2	100.0	H	0.0	34.2	-6.0	25.8	54
2058.000000	29.4	100.0	V	1.0	34.0	-4.6	24.6	54
2477.000000	30.5	100.0	H	267.0	33.4	-2.9	23.5	54
2506.500000	30.8	100.0	V	15.0	33.6	-2.8	23.2	54

Remark: 1. Correction Factor = Antenna factor+ Insertion loss (cable loss + amplifier gain)

RE 3-18GHz PK+AV

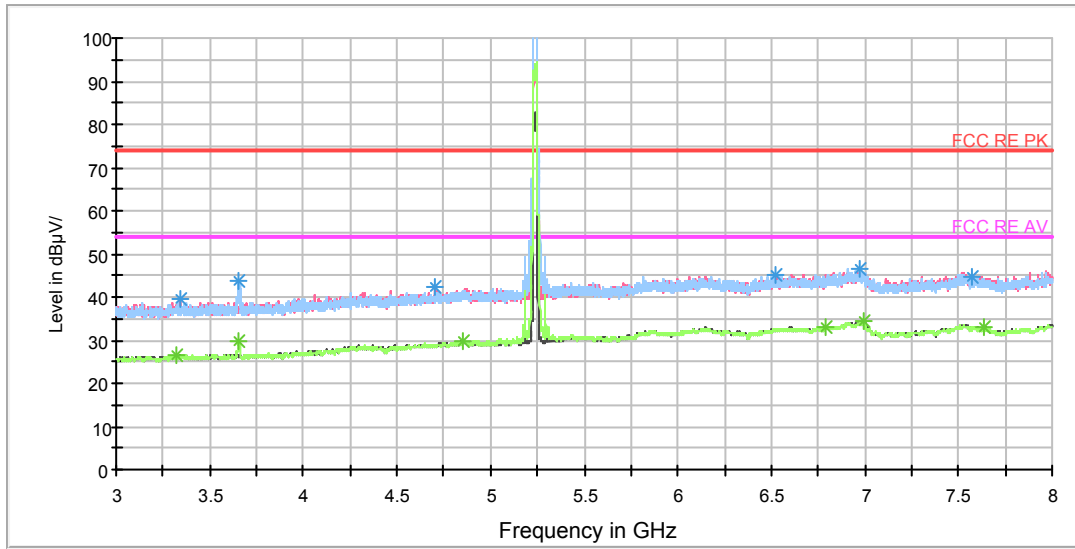

Note: The signal beyond the limit is carrier.  
Radiates Emission from 3GHz to 8Hz

Frequency (MHz)	Peak (dBuV/m)	Height (cm)	Polarization	Azimuth (deg)	Reading value (dBuV/m)	Correct Factor (dB)	Margin (dB)	Limit (dBuV/m)
3343.750000	39.4	100.0	V	330.0	41.8	-2.4	34.6	74
3651.250000	43.9	100.0	H	33.0	45.8	-1.9	30.1	74
4701.875000	42.3	100.0	V	279.0	41.5	0.8	31.7	74
6524.375000	45.3	100.0	V	205.0	39.8	5.5	28.7	74
6968.125000	46.6	100.0	H	107.0	40.3	6.3	27.4	74
7575.625000	44.7	100.0	V	154.0	37.6	7.1	29.3	74

Remark: 1. Correction Factor = Antenna factor+ Insertion loss (cable loss + amplifier gain)

Frequency (MHz)	Average (dBuV/m)	Height (cm)	Polarization	Azimuth (deg)	Reading value (dBuV/m)	Correct Factor (dB)	Margin (dB)	Limit (dBuV/m)
3320.000000	26.5	100.0	V	19.0	28.5	-2.0	27.5	54
3655.000000	30.0	100.0	H	0.0	31.9	-1.9	24.0	54
4857.500000	29.7	100.0	V	0.0	28.0	1.7	24.3	54
6791.250000	33.1	100.0	V	355.0	27.4	5.7	20.9	54
6994.375000	34.3	100.0	V	330.0	27.8	6.5	19.7	54
7640.000000	32.9	100.0	V	0.0	26.0	6.9	21.1	54

Remark: 1. Correction Factor = Antenna factor+ Insertion loss (cable loss + amplifier gain)

RE 3-18GHz PK+AV

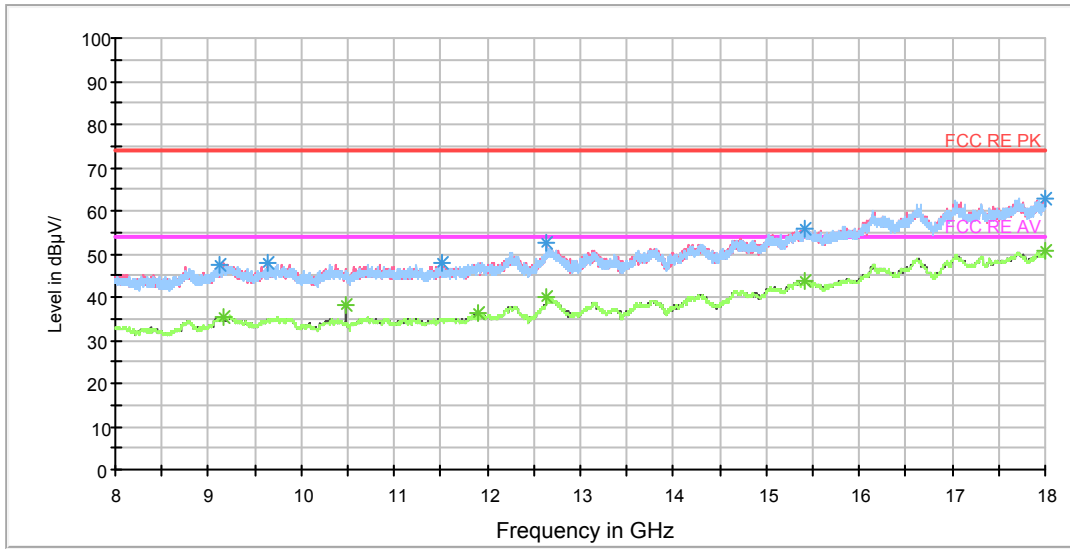

Radiates Emission from 8GHz to 18GHz

Frequency (MHz)	Peak (dBuV/m)	Height (cm)	Polarization	Azimuth (deg)	Reading value (dBuV/m)	Correct Factor (dB)	Margin (dB)	Limit (dBuV/m)
9120.000000	47.2	200.0	H	351.0	37.1	10.1	26.8	74
9637.500000	47.8	100.0	V	165.0	37.9	9.9	26.2	74
11508.750000	48.1	100.0	V	0.0	37.5	10.6	25.9	74
12642.500000	52.4	100.0	H	0.0	37.9	14.5	21.6	74
15418.750000	55.6	100.0	V	0.0	36.2	19.4	18.4	74
17996.250000	62.8	100.0	V	137.0	37.4	25.4	11.2	74

Remark: 1. Correction Factor = Antenna factor+ Insertion loss (cable loss + amplifier gain)

Frequency (MHz)	Average (dBuV/m)	Height (cm)	Polarization	Azimuth (deg)	Reading value (dBuV/m)	Correct Factor (dB)	Margin (dB)	Limit (dBuV/m)
9153.750000	35.2	100.0	H	10.0	25.0	10.2	18.8	54
10480.000000	38.2	100.0	V	80.0	28.1	10.1	15.8	54
11900.000000	36.5	200.0	V	89.0	24.2	12.3	17.5	54
12641.250000	40.0	100.0	H	226.0	25.5	14.5	14.0	54
15422.500000	43.8	100.0	V	0.0	24.4	19.4	10.2	54
18000.000000	50.5	100.0	V	52.0	25.0	25.5	3.5	54

Remark: 1. Correction Factor = Antenna factor+ Insertion loss (cable loss + amplifier gain)

RE 18-26.5GHz PK+AV

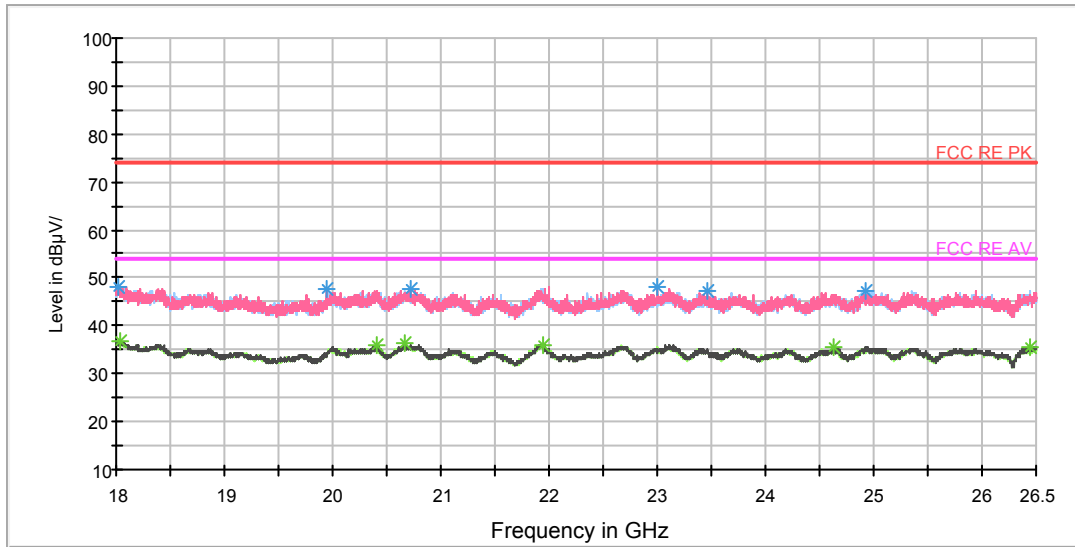

Radiates Emission from 18GHz to 26.5GHz

Frequency (MHz)	Peak (dBuV/m)	Polarization	Azimuth (deg)	Reading value (dBuV/m)	Correct Factor (dB)	Margin (dB)	Limit (dBuV/m)
18009.562500	48.3	H	0.0	50.1	-1.8	25.7	74
19950.750000	47.9	V	0.0	53.6	-5.7	26.1	74
20718.937500	47.6	H	255.0	54.3	-6.7	26.4	74
22993.750000	47.9	V	195.0	54.1	-6.2	26.1	74
23458.062500	47.1	V	65.0	53.0	-5.9	26.9	74
24933.875000	47.4	H	179.0	53.3	-5.9	26.6	74

Remark: 1. Correction Factor = Antenna factor+ Insertion loss (cable loss + amplifier gain)

Frequency (MHz)	Average (dBuV/m)	Polarization	Azimuth (deg)	Reading value (dBuV/m)	Correct Factor (dB)	Margin (dB)	Limit (dBuV/m)
18031.875000	36.8	H	0.0	38.7	-1.9	17.2	54
20403.375000	35.9	V	205.0	42.0	-6.1	18.1	54
20672.187500	36.3	V	248.0	42.9	-6.6	17.7	54
21950.375000	36.1	V	1.0	44.1	-8.0	17.9	54
24632.125000	35.4	V	352.0	41.4	-6.0	18.6	54
26451.125000	35.6	V	205.0	41.0	-5.4	18.4	54

Remark: 1. Correction Factor = Antenna factor+ Insertion loss (cable loss + amplifier gain)