

FCC SAR Test Report

APPLICANT : Lenovo (Shanghai) Electronics Technology Co., Ltd.
EQUIPMENT : Portable Tablet Computer
BRAND NAME : lenovo
MODEL NAME : Lenovo A3300-H
MARKETING NAME : Lenovo A3300-H
FCC ID : O57A3300H
STANDARD : FCC 47 CFR Part 2 (2.1093)
ANSI/IEEE C95.1-1992
IEEE 1528-2003

We, SPORTON INTERNATIONAL (XI'AN) INC., would like to declare that the tested sample has been evaluated in accordance with the procedures and had been in compliance with the applicable technical standards.

The test results in this report apply exclusively to the tested model / sample. Without written approval of SPORTON INTERNATIONAL (XI'AN) INC., the test report shall not be reproduced except in full.

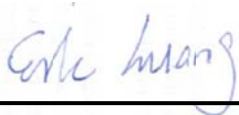

Reviewed by: Eric Huang / Deputy Manager



Approved by: Jones Tsai / Manager



SPORTON INTERNATIONAL (XI'AN) INC.
1F, Building A3, No. 39 Chuangye Rd., Xi'an Hi-tech Zone, Shanxi Province, P.R.C.



Table of Contents

1. Statement of Compliance4

2. Administration Data5

3. Guidance Standard5

4. Equipment Under Test (EUT)6

 4.1 General Information6

 4.2 Maximum Tune-up Limit7

5. Proximity Sensor Triggering Test.....8

6. RF Exposure Limits13

 6.1 Uncontrolled Environment13

 6.2 Controlled Environment13

7. Specific Absorption Rate (SAR).....14

 7.1 Introduction14

 7.2 SAR Definition14

8. System Description and Setup15

9. Measurement Procedures16

 9.1 Spatial Peak SAR Evaluation16

 9.2 Power Reference Measurement17

 9.3 Area Scan17

 9.4 Zoom Scan18

 9.5 Volume Scan Procedures18

 9.6 Power Drift Monitoring18

10. Test Equipment List19

11. System Verification20

 11.1 Tissue Verification20

 11.2 System Performance Check Results21

12. RF Exposure Positions22

 12.1 SAR Testing for Tablet22

13. Conducted RF Output Power (Unit: dBm)23

14. Bluetooth Exclusions Applied29

15. Antenna Location30

16. SAR Test Results32

 16.1 Body SAR33

 16.2 Repeated SAR Measurement35

17. Simultaneous Transmission Analysis36

 17.1 Body Accessory Exposure Conditions37

 17.2 SPLSR Evaluation and Analysis39

18. Uncertainty Assessment41

19. References43

Appendix A. Plots of System Performance Check

Appendix B. Plots of High SAR Measurement

Appendix C. DASYS Calibration Certificate

Appendix D. Test Setup Photos



1. Statement of Compliance

The maximum results of Specific Absorption Rate (SAR) found during testing for **Lenovo (Shanghai) Electronics Technology Co., Ltd., Portable Tablet Computer, Lenovo A3300-H**, are as follows.

Equipment Class	Frequency Band	Operating Mode	Highest SAR Summary	
			Body 1g SAR (W/kg)	Simultaneous Transmission SAR (W/kg)
PCB	GSM850	Data	0.74	1.24
	GSM1900	Data	1.16	
	WCDMA Band V	Data	0.55	
	WCDMA Band II	Data	1.05	
DTS	WLAN 2.4GHz Band	Data	1.13	1.16
DSS	Bluetooth	Data		1.24
Date of Testing:			05/14/2014 ~ 05/26/2014	

This device is in compliance with Specific Absorption Rate (SAR) for general population/uncontrolled exposure limits (1.6 W/kg) specified in FCC 47 CFR part 2 (2.1093) and ANSI/IEEE C95.1-1992, and had been tested in accordance with the measurement methods and procedures specified in IEEE 1528-2003.



2. Administration Data

Testing Laboratory	
Test Site	SPORTON INTERNATIONAL (XI'AN) INC.
Test Site Location	1F, Building A3, No. 39 Chuangye Rd., Xi'an Hi-tech Zone, Shanxi Province, P. R. C. TEL: +86-029-8860-8767 FAX: +86-029-8860-8791

Applicant	
Company Name	Lenovo (Shanghai) Electronics Technology Co., Ltd.
Address	No. 68 Building, 199 Fenju Road, Wai Gao Qiao FTZ , Shanghai , China

Manufacturer	
Company Name	Lenovo PC HK Limited
Address	23/F, Lincoln House, Taikoo Place 979 King's Road, Quarry Bay, Hong Kong

3. Guidance Standard

The Specific Absorption Rate (SAR) testing specification, method, and procedure for this device is in accordance with the following standards:

- FCC 47 CFR Part 2 (2.1093)
- ANSI/IEEE C95.1-1992
- IEEE 1528-2003
- FCC KDB 865664 D01 SAR Measurement 100 MHz to 6 GHz v01r03
- FCC KDB 865664 D02 SAR Reporting v01r01
- FCC KDB 447498 D01 General RF Exposure Guidance v05r02
- FCC KDB 248227 D01 SAR meas for 802 11abg v01r02
- FCC KDB 616217 D04 SAR for laptop and tablets v01r01
- FCC KDB 941225 D01 SAR test for 3G devices v02
- FCC KDB 941225 D02 HSPA and 1x Advanced v02r02
- FCC KDB 941225 D03 SAR Test Reduction GSM GPRS EDGE v01



4. Equipment Under Test (EUT)

4.1 General Information

Product Feature & Specification	
Equipment Name	Portable Tablet Computer
Brand Name	lenovo
Model Name	Lenovo A3300-H
Marketing Name	Lenovo A3300-H
FCC ID	O57A3300H
IMEI Code	123456789965684
Wireless Technology and Frequency Range	GSM850: 824.2 MHz ~ 848.8 MHz GSM1900: 1850.2 MHz ~ 1909.8 MHz WCDMA Band V: 826.4 MHz ~ 846.6 MHz WCDMA Band II: 1852.4 MHz ~ 1907.6 MHz WLAN 2.4GHz Band: 2412 MHz ~ 2462 MHz Bluetooth: 2402 MHz ~ 2480 MHz
Mode	<ul style="list-style-type: none">• GSM/GPRS/EGPRS• RMC/AMR 12.2Kbps• HSDPA• HSUPA• HSPA+ (Downlink Only)• 802.11b/g/nHT20/HT40• Bluetooth v3.0+EDR , Bluetooth v4.0 LE
HW Version	A977_MB_PCB_V4.0
SW Version	A3300H_A442_01_04_140522_ROW
EUT Stage	Pre-Production
Remark: <ol style="list-style-type: none">1. This device supports GRPS/EGPRS mode up to multi-slot class12.2. There are two types of EUT sample 1 and sample 2. The differences between two samples are only different supplier for Touch panel/LCD panel and battery cell. For SAR test, only perform sample 1 for all test, and sample 2 verified the worse mode.3. This device does not support Voice for software disabled this function.	



4.2 Maximum Tune-up Limit

Burst Average Power (dBm)				
Mode / Band	GSM850		GSM1900	
Output Power Status	Full power mode	Reduced power mode	Full power mode	Reduced power mode
GSM (GMSK, 1 Tx slot)	32.5	28	29.5	24
GPRS (GMSK, 1 Tx slot)	32.5	28	29.5	24
GPRS (GMSK, 2 Tx slots)	30	25.5	26.5	22.5
GPRS (GMSK, 3 Tx slots)	28.5	24	24.5	21
GPRS (GMSK, 4 Tx slots)	27.5	23	24.5	20.5
EDGE (8PSK, 1 Tx slot)	27	22.5	26.5	21
EDGE (8PSK, 2 Tx slots)	26	21	25.5	18
EDGE (8PSK, 3 Tx slots)	24	19	23.5	16.5
EDGE (8PSK, 4 Tx slots)	23	17	22.5	15

Average Power (dBm)				
Mode / Band	WCDMA Band V		WCDMA Band II	
Output Power Status	Full power mode	Reduced power mode	Full power mode	Reduced power mode
AMR 12.2K	22.5	17.5	22.5	17.5
RMC 12.2K	22.5	17.5	22.5	17.5
HSDPA Subtest-1	21.5	16.5	21.5	17
HSDPA Subtest-2	21.5	16.5	21.5	17
HSDPA Subtest-3	21.5	16.5	21.5	17
HSDPA Subtest-4	21.5	16.5	21.5	17
HSUPA Subtest-1	21.5	16.5	21	17
HSUPA Subtest-2	21	16.5	21	17
HSUPA Subtest-3	21	17	21	16
HSUPA Subtest-4	21	17	21	16.5
HSUPA Subtest-5	21	17	21	16.5

Mode			Maximum Average Power (dBm)
2.4GHz	802.11b	CH1	13
		CH6	13
		CH11	13.5

Mode			Maximum Average Power (dBm)
2.4GHz	802.11g		9
	802.11n-HT20		8
	802.11n-HT40		8
Bluetooth v3.0+EDR			3
Bluetooth v4.0 LE			-5

5. Proximity Sensor Triggering Test

<Proximity Sensor Triggering Distance (KDB 616217 D04 section 6.2)>:

Proximity sensor triggering distance testing was performed according to the procedures outlined in KDB 616217 D04 section 6.2, and EUT moving further away from the flat phantom and EUT moving toward the flat phantom were both assessed. The details are illustrated in the exhibit “P-Sensor operational description”, and the shortest triggering distances were reported and used for SAR assessment.

In the preliminary triggering distance testing, the tissue-equivalent medium for different frequency bands were used for verification; no other frequency bands tissue-equivalent medium was found to result in shortest triggering distance than that for 1900MHz, and the tissue-equivalent medium for 1900MHz was used for formal proximity sensor triggering testing.

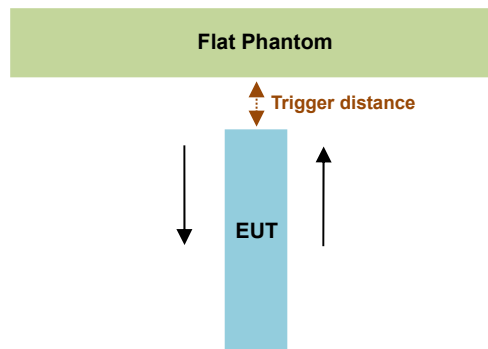

Proximity Sensor Trigger Distance (mm)			
Position	Bottom Face	Edge 1	Edge 2
Minimum	19	10	7

<Proximity Sensor Triggering Coverage (KDB 616217 D04 section 6.3)>:

If a sensor is spatially offset from the antenna(s), it is necessary to verify sensor triggering for conditions where the antenna is next to the user but the sensor is laterally further away to ensure sensor coverage is sufficient for reducing the power to maintain compliance. For p-sensor coverage testing, the device is moved and “along the direction of maximum antenna and sensor offset”.

Illustrated in the internal photo exhibit, although the sensor is spatially offset, there is no trigger condition where the antenna is next to the user but the sensor is laterally further away, therefore proximity sensor coverage testing is not required.

<Tablet Tilt angle influences to proximity sensor triggering (KDB 616217 D04 section 6.4)>:

The influence of table tilt angles to proximity sensor triggering was determined by positioning each tablet edge that contains a transmitting antenna, perpendicular to the flat phantom, at 13 mm separation. Rotating the tablet around the edge next to the phantom in $\leq 10^\circ$ increments until the tablet is $\pm 45^\circ$ from the vertical position at 0° , and the maximum output power remains in the reduced mode.

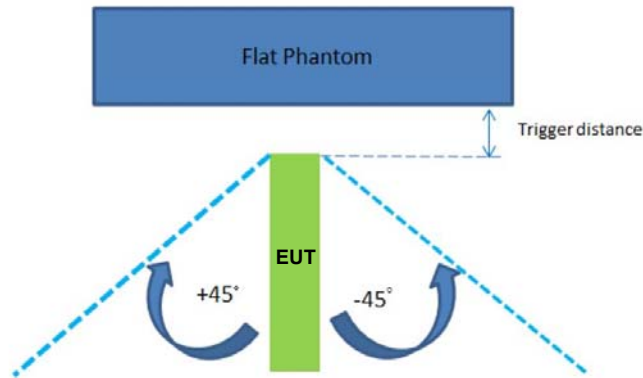

The Sensor Trigger Distance (mm)		
Position	Edge 1	Edge 2
Minimum	10	7

Proximity sensor power reduction

Exposure Position / wireless mode	Bottom Face ⁽¹⁾	Edge 1 ⁽¹⁾	Edge 2 ⁽¹⁾	Edge 3	Edge 4
GSM850 GPRS (GMSK 1 Tx slot) - CS1	4.5 dB	4.5 dB	4.5 dB	0 dB	0 dB
GSM850 GPRS (GMSK 2 Tx slot) - CS1	4.5 dB	4.5 dB	4.5 dB	0 dB	0 dB
GSM850 GPRS (GMSK 3 Tx slots) - CS1	4.5 dB	4.5 dB	4.5 dB	0 dB	0 dB
GSM850 GPRS (GMSK 4 Tx slots) - CS1	4.5 dB	4.5 dB	4.5 dB	0 dB	0 dB
GSM850 EDGE (8PSK 1 Tx slot) - MCS5	4.5 dB	4.5 dB	4.5 dB	0 dB	0 dB
GSM850 EDGE (8PSK 2 Tx slot) - MCS5	5.0 dB	5.0 dB	5.0 dB	0 dB	0 dB
GSM850 EDGE (8PSK 3 Tx slot) - MCS5	5.0 dB	5.0 dB	5.0 dB	0 dB	0 dB
GSM850 EDGE (8PSK 4 Tx slot) - MCS5	6.0 dB	6.0 dB	6.0 dB	0 dB	0 dB
GSM1900 GPRS (GMSK 1 Tx slot) - CS1	5.5 dB	5.5 dB	5.5 dB	0 dB	0 dB
GSM1900 GPRS (GMSK 2 Tx slot) - CS1	4.0 dB	4.0 dB	4.0 dB	0 dB	0 dB
GSM1900 GPRS (GMSK 3 Tx slots) - CS1	3.5 dB	3.5 dB	3.5 dB	0 dB	0 dB
GSM1900 GPRS (GMSK 4 Tx slots) - CS1	4.0 dB	4.0 dB	4.0 dB	0 dB	0 dB
GSM1900 EDGE (8PSK 1 Tx slot) - MCS5	5.5 dB	5.5 dB	5.5 dB	0 dB	0 dB
GSM1900 EDGE (8PSK 2 Tx slot) - MCS5	7.5 dB	7.5 dB	7.5 dB	0 dB	0 dB
GSM1900 EDGE (8PSK 3 Tx slot) - MCS5	7.0 dB	7.0 dB	7.0 dB	0 dB	0 dB
GSM1900 EDGE (8PSK 4 Tx slot) - MCS5	7.5 dB	7.5 dB	7.5 dB	0 dB	0 dB
WCDMA Band V RMC 12.2kbps	5.0 dB	5.0 dB	5.0 dB	0 dB	0 dB
WCDMA Band II RMC 12.2kbps	5.0 dB	5.0 dB	5.0 dB	0 dB	0 dB

Remark:

1. ⁽¹⁾: Reduced maximum limit applied by activation of proximity sensor.
2. Power reduction is not applicable for WLAN and Bluetooth.
3. Tests were performed in accordance with KDB 616217 D04 section 6.1, 6.2, 6.3, 6.4 and 6.5 and compliant results are shown and described in exhibit "P-Sensor operational description"
4. For verification of compliance of power reduction scheme, additional SAR testing with EUT transmitting at full RF power at a conservative trigger distance was performed:
 - Bottom Face: 9 mm
 - Edge1: 4 mm
 - Edge2: 4 mm



Power Measurement during Sensor Trigger distance testing

Band/Mode	Ch #	Measured power reduction (dBm)		Reduction Levels (dB)
		w/o power back-off	w/ power back-off	
GSM850 GPRS (GMSK 4 Tx slot)	189	26.49	22.26	4.23
GSM1900 GPRS (GMSK 4 Tx slot)	661	23.27	19.23	4.04
WCDMA Band V (RMC 12.2Kbps)	4182	21.68	16.74	4.94
WCDMA Band II (RMC 12.2Kbps)	9400	21.46	16.47	4.99

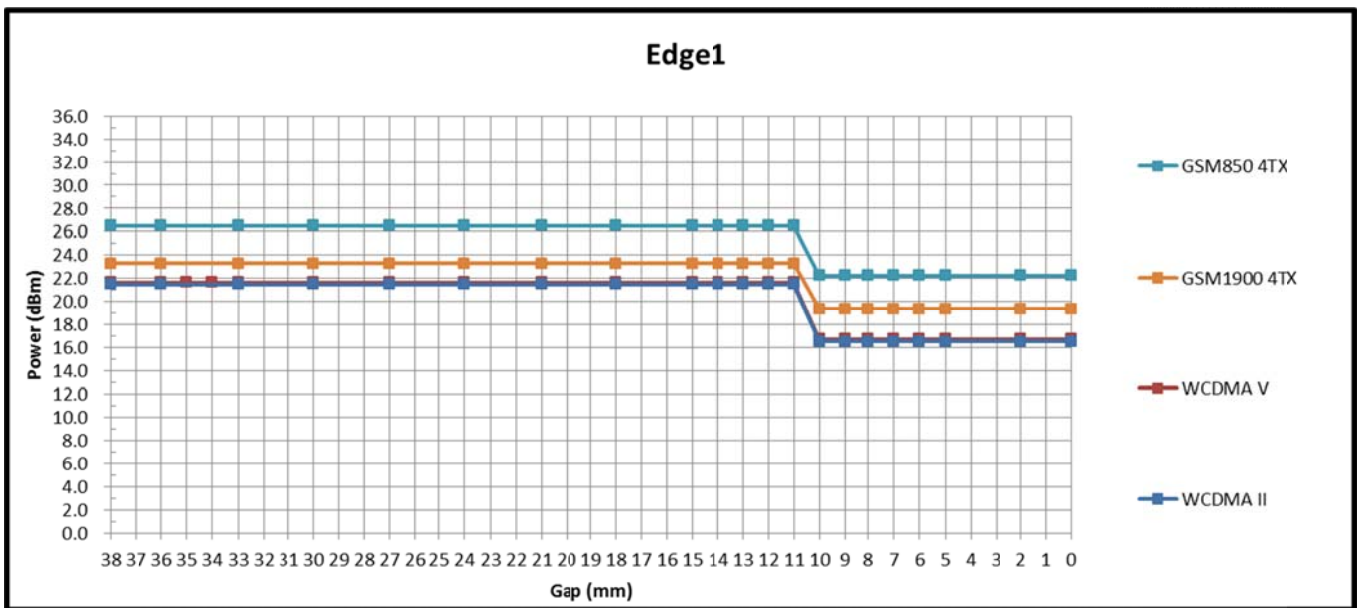
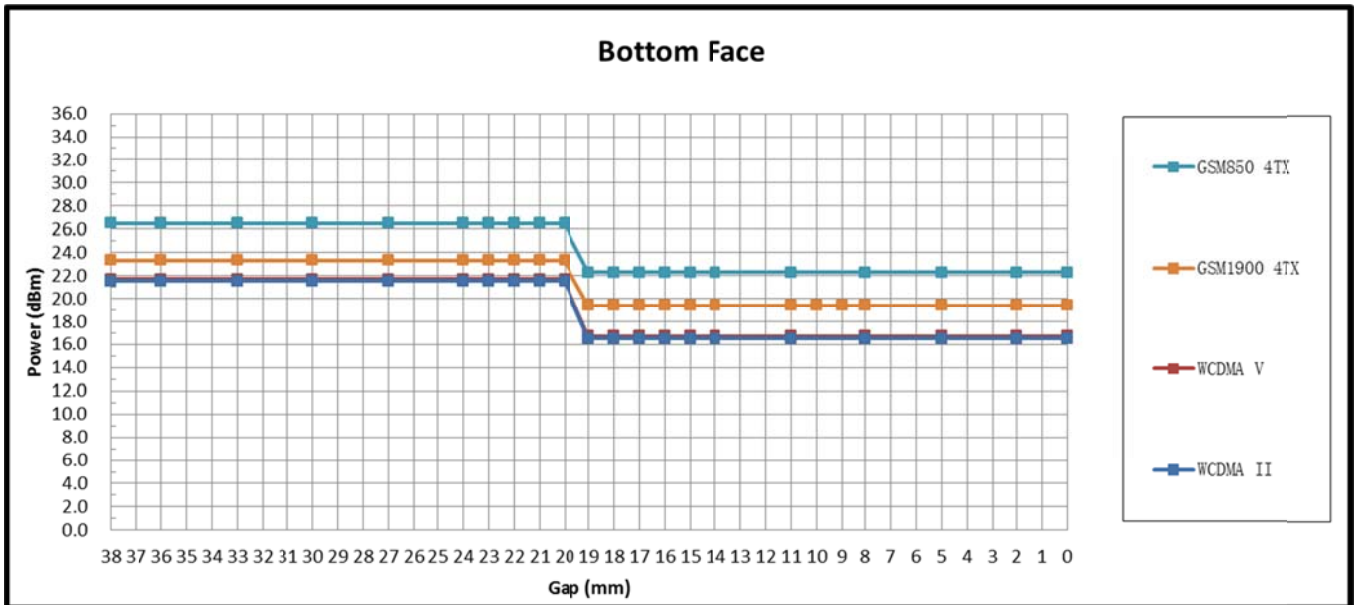

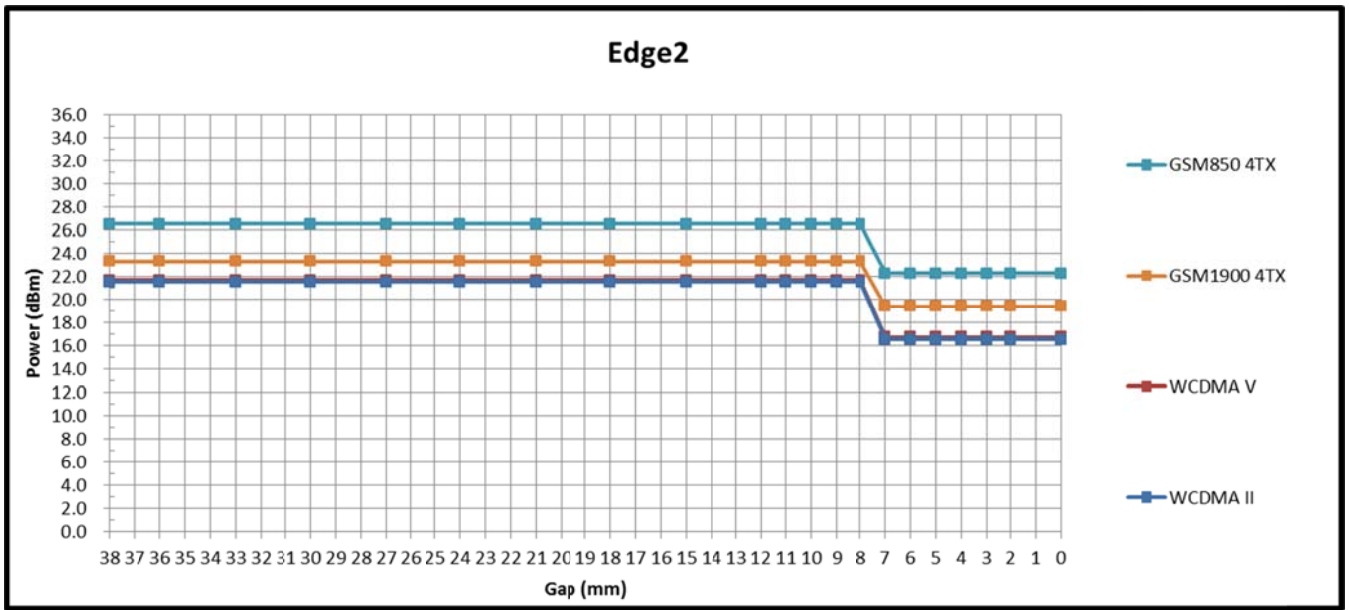

6. RF Exposure Limits

6.1 Uncontrolled Environment

Uncontrolled Environments are defined as locations where there is the exposure of individuals who have no knowledge or control of their exposure. The general population/uncontrolled exposure limits are applicable to situations in which the general public may be exposed or in which persons who are exposed as a consequence of their employment may not be made fully aware of the potential for exposure or cannot exercise control over their exposure. Members of the general public would come under this category when exposure is not employment-related; for example, in the case of a wireless transmitter that exposes persons in its vicinity.

6.2 Controlled Environment

Controlled Environments are defined as locations where there is exposure that may be incurred by persons who are aware of the potential for exposure, (i.e. as a result of employment or occupation). In general, occupational/controlled exposure limits are applicable to situations in which persons are exposed as a consequence of their employment, who have been made fully aware of the potential for exposure and can exercise control over their exposure. The exposure category is also applicable when the exposure is of a transient nature due to incidental passage through a location where the exposure levels may be higher than the general population/uncontrolled limits, but the exposed person is fully aware of the potential for exposure and can exercise control over his or her exposure by leaving the area or by some other appropriate means.

Limits for Occupational/Controlled Exposure (W/kg)

Whole-Body	Partial-Body	Hands, Wrists, Feet and Ankles
0.4	8.0	20.0

Limits for General Population/Uncontrolled Exposure (W/kg)

Whole-Body	Partial-Body	Hands, Wrists, Feet and Ankles
0.08	1.6	4.0

1. Whole-Body SAR is averaged over the entire body, partial-body SAR is averaged over any 1gram of tissue defined as a tissue volume in the shape of a cube. SAR for hands, wrists, feet and ankles is averaged over any 10 grams of tissue defined as a tissue volume in the shape of a cube.

7. Specific Absorption Rate (SAR)

7.1 Introduction

SAR is related to the rate at which energy is absorbed per unit mass in an object exposed to a radio field. The SAR distribution in a biological body is complicated and is usually carried out by experimental techniques or numerical modeling. The standard recommends limits for two tiers of groups, occupational/controlled and general population/uncontrolled, based on a person's awareness and ability to exercise control over his or her exposure. In general, occupational/controlled exposure limits are higher than the limits for general population/uncontrolled.

7.2 SAR Definition

The SAR definition is the time derivative (rate) of the incremental energy (dW) absorbed by (dissipated in) an incremental mass (dm) contained in a volume element (dv) of a given density (ρ). The equation description is as below:

$$SAR = \frac{d}{dt} \left(\frac{dW}{dm} \right) = \frac{d}{dt} \left(\frac{dW}{\rho dv} \right)$$

SAR is expressed in units of Watts per kilogram (W/kg)

$$SAR = \frac{\sigma |E|^2}{\rho}$$

Where: σ is the conductivity of the tissue, ρ is the mass density of the tissue and E is the RMS electrical field strength.

8. System Description and Setup

The DASY system used for performing compliance tests consists of the following items:

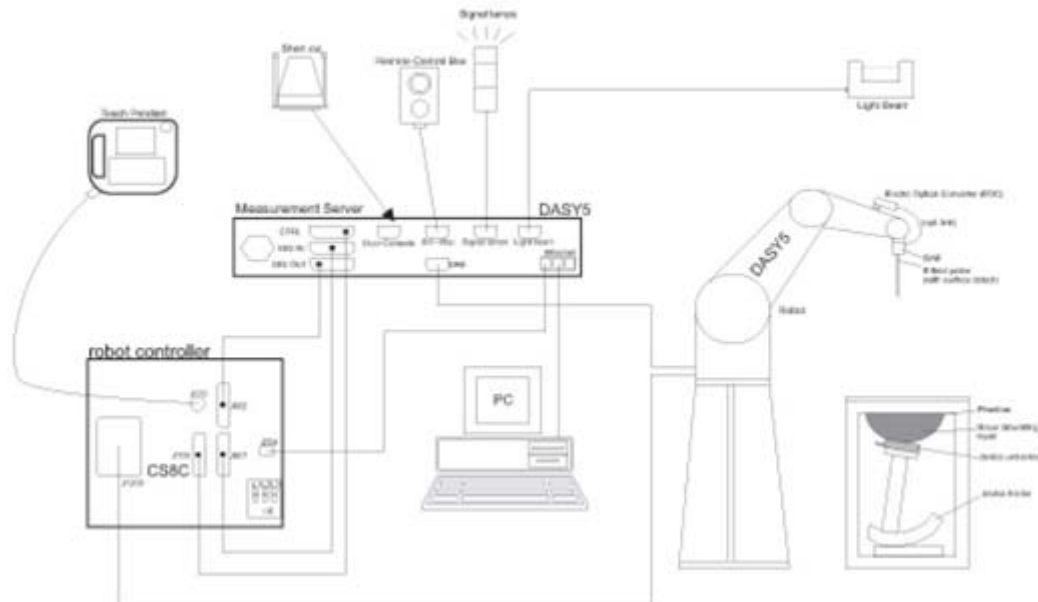

- A standard high precision 6-axis robot with controller, teach pendant and software. An arm extension for accommodating the data acquisition electronics (DAE).
- An isotropic Field probe optimized and calibrated for the targeted measurement.
- A data acquisition electronics (DAE) which performs the signal amplification, signal multiplexing, AD-conversion, offset measurements, mechanical surface detection, collision detection, etc. The unit is battery powered with standard or rechargeable batteries. The signal is optically transmitted to the EOC.
- The Electro-optical converter (EOC) performs the conversion from optical to electrical signals for the digital communication to the DAE. To use optical surface detection, a special version of the EOC is required. The EOC signal is transmitted to the measurement server.
- The function of the measurement server is to perform the time critical tasks such as signal filtering, control of the robot operation and fast movement interrupts.
- The Light Beam used is for probe alignment. This improves the (absolute) accuracy of the probe positioning.
- A computer running WinXP or Win7 and the DASY5 software.
- Remote control and teach pendant as well as additional circuitry for robot safety such as warning lamps, etc.
- The phantom, the device holder and other accessories according to the targeted measurement.



9. Measurement Procedures

The measurement procedures are as follows:

<Conducted power measurement>

- (a) For WWAN power measurement, use base station simulator to configure EUT WWAN transmission in conducted connection with RF cable, at maximum power in each supported wireless interface and frequency band.
- (b) Read the WWAN RF power level from the base station simulator.
- (c) For WLAN/BT power measurement, use engineering software to configure EUT WLAN/BT continuously transmission, at maximum RF power in each supported wireless interface and frequency band
- (d) Connect EUT RF port through RF cable to the power meter, and measure WLAN/BT output power

<SAR measurement>

- (a) Use base station simulator to configure EUT WWAN transmission in radiated connection, and engineering software to configure EUT WLAN/BT continuously transmission, at maximum RF power, in the highest power channel.
- (b) Place the EUT in the positions as Appendix D demonstrates.
- (c) Set scan area, grid size and other setting on the DASY software.
- (d) Measure SAR results for the highest power channel on each testing position.
- (e) Find out the largest SAR result on these testing positions of each band
- (f) Measure SAR results for other channels in worst SAR testing position if the reported SAR of highest power channel is larger than 0.8 W/kg

According to the test standard, the recommended procedure for assessing the peak spatial-average SAR value consists of the following steps:

- (a) Power reference measurement
- (b) Area scan
- (c) Zoom scan
- (d) Power drift measurement

9.1 Spatial Peak SAR Evaluation

The procedure for spatial peak SAR evaluation has been implemented according to the test standard. It can be conducted for 1g and 10g, as well as for user-specific masses. The DASY software includes all numerical procedures necessary to evaluate the spatial peak SAR value.

The base for the evaluation is a "cube" measurement. The measured volume must include the 1g and 10g cubes with the highest averaged SAR values. For that purpose, the center of the measured volume is aligned to the interpolated peak SAR value of a previously performed area scan.

The entire evaluation of the spatial peak values is performed within the post-processing engine (SEMCAD). The system always gives the maximum values for the 1g and 10g cubes. The algorithm to find the cube with highest averaged SAR is divided into the following stages:

- (a) Extraction of the measured data (grid and values) from the Zoom Scan
- (b) Calculation of the SAR value at every measurement point based on all stored data (A/D values and measurement parameters)
- (c) Generation of a high-resolution mesh within the measured volume
- (d) Interpolation of all measured values from the measurement grid to the high-resolution grid
- (e) Extrapolation of the entire 3-D field distribution to the phantom surface over the distance from sensor to surface
- (f) Calculation of the averaged SAR within masses of 1g and 10g



9.2 Power Reference Measurement

The Power Reference Measurement and Power Drift Measurements are for monitoring the power drift of the device under test in the batch process. The minimum distance of probe sensors to surface determines the closest measurement point to phantom surface. This distance cannot be smaller than the distance of sensor calibration points to probe tip as defined in the probe properties.

9.3 Area Scan

The area scan is used as a fast scan in two dimensions to find the area of high field values, before doing a fine measurement around the hot spot. The sophisticated interpolation routines implemented in DASY software can find the maximum found in the scanned area, within a range of the global maximum. The range (in dB0 is specified in the standards for compliance testing. For example, a 2 dB range is required in IEEE standard 1528 and IEC 62209 standards, whereby 3 dB is a requirement when compliance is assessed in accordance with the ARIB standard (Japan), if only one zoom scan follows the area scan, then only the absolute maximum will be taken as reference. For cases where multiple maximums are detected, the number of zoom scans has to be increased accordingly.

Area scan parameters extracted from FCC KDB 865664 D01v01r03 SAR measurement 100 MHz to 6 GHz.

Table with 3 columns: Parameter, ≤ 3 GHz, > 3 GHz. Rows include: Maximum distance from closest measurement point, Maximum probe angle from probe axis to phantom surface, and Maximum area scan spatial resolution.

9.4 Zoom Scan

Zoom scans are used assess the peak spatial SAR values within a cubic averaging volume containing 1 gram and 10 gram of simulated tissue. The zoom scan measures points (refer to table below) within a cube shoes base faces are centered on the maxima found in a preceding area scan job within the same procedure. When the measurement is done, the zoom scan evaluates the averaged SAR for 1 gram and 10 gram and displays these values next to the job's label.

Zoom scan parameters extracted from FCC KDB 865664 D01v01r03 SAR measurement 100 MHz to 6 GHz.

		≤ 3 GHz	> 3 GHz	
Maximum zoom scan spatial resolution: $\Delta x_{Zoom}, \Delta y_{Zoom}$		≤ 2 GHz: ≤ 8 mm 2 – 3 GHz: ≤ 5 mm*	3 – 4 GHz: ≤ 5 mm* 4 – 6 GHz: ≤ 4 mm*	
Maximum zoom scan spatial resolution, normal to phantom surface	uniform grid: $\Delta z_{Zoom}(n)$	≤ 5 mm	3 – 4 GHz: ≤ 4 mm 4 – 5 GHz: ≤ 3 mm 5 – 6 GHz: ≤ 2 mm	
	graded grid	$\Delta z_{Zoom}(1)$: between 1 st two points closest to phantom surface	≤ 4 mm	3 – 4 GHz: ≤ 3 mm 4 – 5 GHz: ≤ 2.5 mm 5 – 6 GHz: ≤ 2 mm
		$\Delta z_{Zoom}(n>1)$: between subsequent points	$\leq 1.5 \cdot \Delta z_{Zoom}(n-1)$	
Minimum zoom scan volume	x, y, z	≥ 30 mm	3 – 4 GHz: ≥ 28 mm 4 – 5 GHz: ≥ 25 mm 5 – 6 GHz: ≥ 22 mm	
Note: δ is the penetration depth of a plane-wave at normal incidence to the tissue medium; see draft standard IEEE P1528-2011 for details. * When zoom scan is required and the <i>reported</i> SAR from the <i>area scan based 1-g SAR estimation</i> procedures of KDB 447498 is ≤ 1.4 W/kg, ≤ 8 mm, ≤ 7 mm and ≤ 5 mm zoom scan resolution may be applied, respectively, for 2 GHz to 3 GHz, 3 GHz to 4 GHz and 4 GHz to 6 GHz.				

9.5 Volume Scan Procedures

The volume scan is used for assess overlapping SAR distributions for antennas transmitting in different frequency bands. It is equivalent to an oversized zoom scan used in standalone measurements. The measurement volume will be used to enclose all the simultaneous transmitting antennas. For antennas transmitting simultaneously in different frequency bands, the volume scan is measured separately in each frequency band. In order to sum correctly to compute the 1g aggregate SAR, the EUT remain in the same test position for all measurements and all volume scan use the same spatial resolution and grid spacing. When all volume scan were completed, the software, SEMCAD postprocessor can combine and subsequently superpose these measurement data to calculating the multiband SAR.

9.6 Power Drift Monitoring

All SAR testing is under the EUT install full charged battery and transmit maximum output power. In DASY measurement software, the power reference measurement and power drift measurement procedures are used for monitoring the power drift of EUT during SAR test. Both these procedures measure the field at a specified reference position before and after the SAR testing. The software will calculate the field difference in dB. If the power drifts more than 5%, the SAR will be retested.



10. Test Equipment List

Manufacturer	Name of Equipment	Type/Model	Serial Number	Calibration	
				Last Cal.	Due Date
SPEAG	835MHz System Validation Kit	D835V2	4d151	Mar. 25, 2013	Mar. 23, 2015
SPEAG	1900MHz System Validation Kit	D1900V2	5d170	Mar. 27, 2013	Mar. 25, 2015
SPEAG	2450MHz System Validation Kit	D2450V2	908	Mar. 26, 2013	Mar. 24, 2015
SPEAG	Data Acquisition Electronics	DAE4	1353	Jan. 30, 2014	Jan. 29, 2015
SPEAG	Dosimetric E-Field Probe	EX3DV4	3898	Mar. 10, 2014	Mar. 09, 2015
SPEAG	Phone Positioner	N/A	N/A	NCR	NCR
Agilent	Wireless Communication Test Set	E5515C	MY52102600	Dec. 30, 2013	Dec. 29, 2014
Agilent	ENA Series Network Analyzer	E5071C	MY46111157	Dec. 30, 2013	Dec. 29, 2014
Agilent	Dielectric Probe Kit	85070E	MY44300751	NCR	NCR
Anritsu	Power Meter	ML2495A	1005002	Feb. 27, 2014	Feb. 26, 2015
Anritsu	Power Sensor	MA2411B	917070	Feb. 27, 2014	Feb. 26, 2015
R&S	Spectrum Analyzer	FSP7	101045	Dec. 30, 2013	Dec. 29, 2014
SPEAG	SAM Twin Phantom	QD 000 P40 CD	TP-1753	NCR	NCR
SPEAG	SAM Twin Phantom	QD 000 P40 CD	TP-1754	NCR	NCR
SPEAG	SAM Twin Phantom	QD OVA 002 AA	TP-1201	NCR	NCR
Agilent	Dual Directional Coupler	778D	50422	Note 2	
Woken	Attenuator	WK0602-XX	N/A	Note 2	
PE	Attenuator	PE7005-10	N/A	Note 2	
PE	Attenuator	PE7005- 3	N/A	Note 2	
AR	Power Amplifier	5S1G4M2	0328767	Note 2	
Mini-Circuits	Power Amplifier	ZVE-3W	162601250	Note 2	
Mini-Circuits	Power Amplifier	ZHL-42W+	13440021344	Note 2	

General Note:

1. The calibration certificate of DASY can be referred to appendix C of this report.
2. Prior to system verification and validation, the path loss from the signal generator to the system check source and the power meter, which includes the amplifier, cable, attenuator and directional coupler were measured by the network analyzer. The reading of the power meter was compensated by the path loss between the signal generator and the power meter, and offset by the path loss difference between the path to the power meter and the path to the system check source to monitor the actual power level fed to the system check source.
3. Referring to KDB 865664 D01v01r03, the dipole calibration interval can be extended to 3 years with justification. The dipoles are also not physically damaged, or repaired during the interval.
4. The justification data of dipole D835V2, SN: 4d151, D1900V2, SN: 5d170, D2450V2, SN: 908 can be found in appendix C. The return loss is < -20dB, within 20% of prior calibration, the impedance is within 5 ohm of prior calibration.



11. System Verification

11.1 Tissue Verification

The following tissue formulations are provided for reference only as some of the parameters have not been thoroughly verified. The composition of ingredients may be modified accordingly to achieve the desired target tissue parameters required for routine SAR evaluation.

Frequency (MHz)	Water (%)	Sugar (%)	Cellulose (%)	Salt (%)	Preventol (%)	DGBE (%)	Conductivity (σ)	Permittivity (ϵ_r)
For Body								
835	50.8	48.2	0	0.9	0.1	0	0.97	55.2
1800, 1900, 2000	70.2	0	0	0.4	0	29.4	1.52	53.3
2450	68.6	0	0	0	0	31.4	1.95	52.7

<Tissue Dielectric Parameter Check Results>

Frequency (MHz)	Tissue Type	Liquid Temp. (°C)	Conductivity (σ)	Permittivity (ϵ_r)	Conductivity Target (σ)	Permittivity Target (ϵ_r)	Delta (σ) (%)	Delta (ϵ_r) (%)	Limit (%)	Date
835	Body	22.4	0.975	54.261	0.97	55.20	0.52	-1.70	±5	2014.05.15
1900	Body	22.5	1.501	53.849	1.52	53.30	-1.25	1.03	±5	2014.05.14
2450	Body	22.6	1.989	51.267	1.95	52.70	2.00	-2.72	±5	2014.05.22
835	Body	22.5	0.974	54.283	0.97	55.20	0.41	-1.66	±5	2014.05.24
1900	Body	22.5	1.519	53.569	1.52	53.30	-0.07	0.50	±5	2014.05.24
2450	Body	22.5	1.983	51.159	1.95	52.70	1.69	-2.92	±5	2014.05.26

11.2 System Performance Check Results

Comparing to the original SAR value provided by SPEAG, the verification data should be within its specification of 10 %. Below table shows the target SAR and measured SAR after normalized to 1W input power. The table below indicates the system performance check can meet the variation criterion and the plots can be referred to Appendix A of this report.

Date	Frequency (MHz)	Tissue Type	Input Power (mW)	Dipole S/N	Probe S/N	DAE S/N	Measured SAR (W/kg)	Targeted SAR (W/kg)	Normalized SAR (W/kg)	Deviation (%)
2014.05.15	835	Body	250	4d151	3898	1353	2.28	9.43	9.12	-3.29
2014.05.14	1900	Body	250	5d170	3898	1353	10.30	41.20	41.2	0.00
2014.05.22	2450	Body	250	908	3898	1353	12.80	50.40	51.2	1.59
2014.05.24	835	Body	250	4d151	3898	1353	2.27	9.43	9.08	-3.71
2014.05.24	1900	Body	250	5d170	3898	1353	10.32	41.20	41.28	0.19
2014.05.26	2450	Body	250	908	3898	1353	12.80	50.40	51.2	1.59

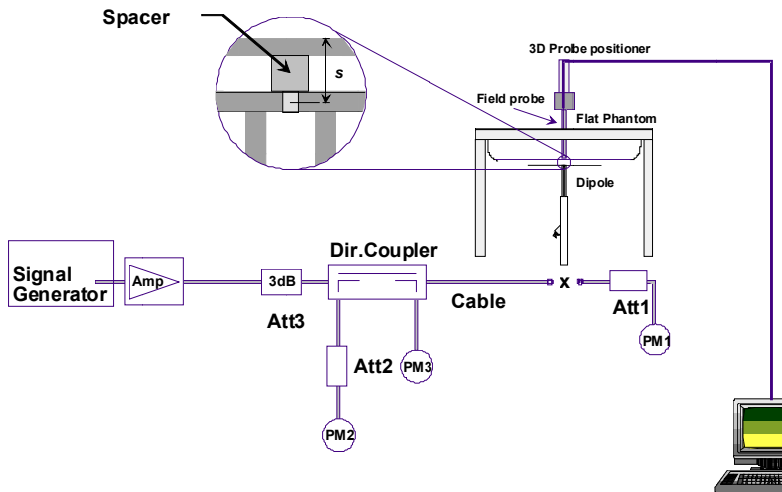

Fig 8.3.1 System Performance Check Setup



Fig 8.3.2 Setup Photo



12. RF Exposure Positions

12.1 SAR Testing for Tablet

This device can be used also in full sized tablet exposure conditions, due to its size. Per FCC KDB 616217, the back surface and edges of the tablet should be tested for SAR compliance with the tablet touching the phantom. The SAR exclusion threshold in KDB 447498 D01v05r02 can be applied to determine SAR test exclusion for adjacent edge configurations. The closest distance from the antenna to an adjacent tablet edge is used to determine if SAR testing is required for the adjacent edges, with the adjacent edge positioned against the phantom and the edge containing the antenna positioned perpendicular to the phantom.



13. Conducted RF Output Power (Unit: dBm)

<GSM Conducted Power>

- Per KDB 447498 D01v05r02, the maximum output power channel is used for SAR testing and for further SAR test reduction.
- For GSM850 and GSM1900 Body SAR testing was following KDB 941225 D03v01, the GPRS 4Tx slots modes was selected when EUT operating without power back-off, the GPRS 4Tx slots modes was selected when EUT operating with power back-off, according to the highest source-based time-averaged output power.

Maximum Average RF Power (Proximity Sensor Inactive)

Band GSM850	Burst Average Power (dBm)			Tune-up Limit (dBm)	Frame-Average Power (dBm)			Tune-up Limit (dBm)
	TX Channel	128	189		251	128	189	
Frequency (MHz)	824.2	836.4	848.8		824.2	836.4	848.8	
GSM (GMSK, 1 Tx slot)	31.86	32.31	32.38	32.5	22.86	23.31	23.38	23.5
GPRS (GMSK, 1 Tx slot) – CS1	31.85	32.29	32.35	32.5	22.85	23.29	23.35	23.5
GPRS (GMSK, 2 Tx slots) – CS1	29.01	29.38	29.43	30	23.01	23.38	23.43	24
GPRS (GMSK, 3 Tx slots) – CS1	27.06	27.42	27.47	28.5	22.80	23.16	23.21	24.24
GPRS (GMSK, 4 Tx slots) – CS1	26.03	26.49	26.51	27.5	23.03	23.49	23.51	24.5
EDGE (8PSK, 1 Tx slot) – MCS5	26.56	26.49	26.45	27	17.56	17.49	17.45	18
EDGE (8PSK, 2 Tx slots) – MCS5	25.64	25.49	25.46	26	19.64	19.49	19.46	20
EDGE (8PSK, 3 Tx slots) – MCS5	23.58	23.46	23.44	24	19.32	19.20	19.18	19.74
EDGE (8PSK, 4 Tx slots) – MCS5	22.62	22.47	22.46	23	19.62	19.47	19.46	20
Band GSM1900	Burst Average Power (dBm)			Tune-up Limit (dBm)	Frame-Average Power (dBm)			Tune-up Limit (dBm)
TX Channel	512	661	810		512	661	810	
Frequency (MHz)	1850.2	1880	1909.8		1850.2	1880	1909.8	
GSM (GMSK, 1 Tx slot)	28.96	29.21	29.27	29.5	19.96	20.21	20.27	20.5
GPRS (GMSK, 1 Tx slot) – CS1	28.94	29.13	29.25	29.5	19.94	20.13	20.25	20.5
GPRS (GMSK, 2 Tx slots) – CS1	25.92	26.11	26.27	26.5	19.92	20.11	20.27	20.5
GPRS (GMSK, 3 Tx slots) – CS1	23.94	24.06	24.21	24.5	19.68	19.80	19.95	20.24
GPRS (GMSK, 4 Tx slots) – CS1	23.03	23.27	23.31	24.5	20.03	20.27	20.31	21.5
EDGE (8PSK, 1 Tx slot) – MCS5	25.60	25.86	26.18	26.5	16.60	16.86	17.18	17.5
EDGE (8PSK, 2 Tx slots) – MCS5	24.62	24.82	25.11	25.5	18.62	18.82	19.11	19.5
EDGE (8PSK, 3 Tx slots) – MCS5	22.50	22.78	23.13	23.5	18.24	18.52	18.87	19.24
EDGE (8PSK, 4 Tx slots) – MCS5	21.52	21.70	22.06	22.5	18.52	18.70	19.06	19.5

Remark: The frame-averaged power is linearly scaled the maximum burst averaged power over 8 time slots.

The calculated method are shown as below:

- Frame-averaged power = Maximum burst averaged power (1 Tx Slot) - 9 dB
- Frame-averaged power = Maximum burst averaged power (2 Tx Slots) - 6 dB
- Frame-averaged power = Maximum burst averaged power (3 Tx Slots) - 4.26 dB
- Frame-averaged power = Maximum burst averaged power (4 Tx Slots) - 3 dB



Reduced Average RF Power (Proximity Sensor active)

Band GSM850	Burst Average Power (dBm)			Tune-up Limit (dBm)	Frame-Average Power (dBm)			Tune-up Limit (dBm)
	TX Channel	128	189		251	128	189	
Frequency (MHz)	824.2	836.4	848.8		824.2	836.4	848.8	
GSM (GMSK, 1 Tx slot)	26.53	26.94	26.96	28	17.53	17.94	17.96	19
GPRS (GMSK, 1 Tx slot) – CS1	26.52	26.93	26.95	28	17.52	17.93	17.95	19
GPRS (GMSK, 2 Tx slots) – CS1	24.73	25.16	25.17	25.5	18.73	19.16	19.17	19.5
GPRS (GMSK, 3 Tx slots) – CS1	23.01	23.46	23.51	24	18.75	19.20	19.25	19.74
GPRS (GMSK, 4 Tx slots) – CS1	21.77	22.26	22.27	23	18.77	19.26	19.27	20
EDGE (8PSK, 1 Tx slot) – MCS5	21.99	21.87	21.92	22.5	12.99	12.87	12.92	13.5
EDGE (8PSK, 2 Tx slots) – MCS5	19.09	18.92	19.02	21	13.09	12.92	13.02	15
EDGE (8PSK, 3 Tx slots) – MCS5	17.32	17.21	17.23	19	13.06	12.95	12.97	14.74
EDGE (8PSK, 4 Tx slots) – MCS5	15.97	15.86	15.93	17	12.97	12.86	12.93	14
Band GSM1900	Burst Average Power (dBm)			Tune-up Limit (dBm)	Frame-Average Power (dBm)			Tune-up Limit (dBm)
TX Channel	512	661	810		512	661	810	
Frequency (MHz)	1850.2	1880	1909.8		1850.2	1880	1909.8	
GSM (GMSK, 1 Tx slot)	23.47	23.62	23.75	24	14.47	14.62	14.75	15
GPRS (GMSK, 1 Tx slot) – CS1	23.45	23.59	23.73	24	14.45	14.59	14.73	15
GPRS (GMSK, 2 Tx slots) – CS1	22.06	22.22	22.37	22.5	16.06	16.22	16.37	16.5
GPRS (GMSK, 3 Tx slots) – CS1	20.36	20.49	20.61	21	16.10	16.23	16.35	16.74
GPRS (GMSK, 4 Tx slots) – CS1	18.97	19.23	19.38	20.5	15.97	16.23	16.38	17.5
EDGE (8PSK, 1 Tx slot) – MCS5	20.54	20.61	20.57	21	11.54	11.61	11.57	12
EDGE (8PSK, 2 Tx slots) – MCS5	17.66	17.76	17.70	18	11.66	11.76	11.70	12
EDGE (8PSK, 3 Tx slots) – MCS5	15.88	16.01	15.93	16.5	11.62	11.75	11.67	12.24
EDGE (8PSK, 4 Tx slots) – MCS5	14.61	14.85	14.72	15	11.61	11.85	11.72	12

Remark: The frame-averaged power is linearly scaled the maximum burst averaged power over 8 time slots.

The calculated method are shown as below:

- Frame-averaged power = Maximum burst averaged power (1 Tx Slot) - 9 dB
- Frame-averaged power = Maximum burst averaged power (2 Tx Slots) - 6 dB
- Frame-averaged power = Maximum burst averaged power (3 Tx Slots) - 4.26 dB
- Frame-averaged power = Maximum burst averaged power (4 Tx Slots) - 3 dB



<WCDMA Conducted Power>

1. The following tests were conducted according to the test requirements outlines in 3GPP TS 34.121 specification.
2. The procedures in KDB 941225 D01 are applied for 3GPP Rel. 6 HSPA to configure the device in the required sub-test mode(s) to determine SAR test exclusion.

A summary of these settings are illustrated below:

HSDPA Setup Configuration:

- a. The EUT was connected to Base Station Agilent E5515C referred to the Setup Configuration.
- b. The RF path losses were compensated into the measurements.
- c. A call was established between EUT and Base Station with following setting:
 - i. Set Gain Factors (β_c and β_d) and parameters were set according to each
 - ii. Specific sub-test in the following table, C10.1.4, quoted from the TS 34.121
 - iii. Set RMC 12.2Kbps + HSDPA mode.
 - iv. Set Cell Power = -86 dBm
 - v. Set HS-DSCH Configuration Type to FRC (H-set 1, QPSK)
 - vi. Select HSDPA Uplink Parameters
 - vii. Set Delta ACK, Delta NACK and Delta CQI = 8
 - viii. Set Ack-Nack Repetition Factor to 3
 - ix. Set CQI Feedback Cycle (k) to 4 ms
 - x. Set CQI Repetition Factor to 2
 - xi. Power Ctrl Mode = All Up bits
- d. The transmitted maximum output power was recorded.

Table C.10.1.4: β values for transmitter characteristics tests with HS-DPCCH

Sub-test	β_c	β_d	β_d (SF)	β_c/β_d	β_{HS} (Note 1, Note 2)	CM (dB) (Note 3)	MPR (dB) (Note 3)
1	2/15	15/15	64	2/15	4/15	0.0	0.0
2	12/15 (Note 4)	15/15 (Note 4)	64	12/15 (Note 4)	24/15	1.0	0.0
3	15/15	8/15	64	15/8	30/15	1.5	0.5
4	15/15	4/15	64	15/4	30/15	1.5	0.5

Note 1: $\Delta_{ACK}, \Delta_{NACK}$ and $\Delta_{CQI} = 30/15$ with $\beta_{HS} = 30/15 * \beta_c$.

Note 2: For the HS-DPCCH power mask requirement test in clause 5.2C, 5.7A, and the Error Vector Magnitude (EVM) with HS-DPCCH test in clause 5.13.1A, and HSDPA EVM with phase discontinuity in clause 5.13.1AA, Δ_{ACK} and $\Delta_{NACK} = 30/15$ with $\beta_{HS} = 30/15 * \beta_c$, and $\Delta_{CQI} = 24/15$ with $\beta_{HS} = 24/15 * \beta_c$.

Note 3: CM = 1 for $\beta_c/\beta_d = 12/15$, $\beta_{HS}/\beta_c = 24/15$. For all other combinations of DPDCH, DPCCH and HS-DPCCH the MPR is based on the relative CM difference. This is applicable for only UEs that support HSDPA in release 6 and later releases.

Note 4: For subtest 2 the β_c/β_d ratio of 12/15 for the TFC during the measurement period (TF1, TF0) is achieved by setting the signalled gain factors for the reference TFC (TF1, TF1) to $\beta_c = 11/15$ and $\beta_d = 15/15$.

Setup Configuration

HSUPA Setup Configuration:

- a. The EUT was connected to Base Station Agilent E5515C referred to the Setup Configuration.
- b. The RF path losses were compensated into the measurements.
- c. A call was established between EUT and Base Station with following setting * :
 - i. Call Configs = 5.2B, 5.9B, 5.10B, and 5.13.2B with QPSK
 - ii. Set the Gain Factors (β_c and β_d) and parameters (AG Index) were set according to each specific sub-test in the following table, C11.1.3, quoted from the TS 34.121
 - iii. Set Cell Power = -86 dBm
 - iv. Set Channel Type = 12.2k + HSPA
 - v. Set UE Target Power
 - vi. Power Ctrl Mode= Alternating bits
 - vii. Set and observe the E-TFCl
 - viii. Confirm that E-TFCl is equal to the target E-TFCl of 75 for sub-test 1, and other subtest's E-TFCl
- d. The transmitted maximum output power was recorded.

Table C.11.1.3: β values for transmitter characteristics tests with HS-DPCCH and E-DCH

Sub-test	β_c	β_d	β_d (SF)	β_c/β_d	β_{HS} (Note 1)	β_{ec}	β_{ed} (Note 5) (Note 6)	β_{ed} (SF)	β_{ed} (Codes)	CM (dB) (Note 2)	MPR (dB) (Note 2)	AG Index (Note 6)	E-TFCl
1	11/15 (Note 3)	15/15 (Note 3)	64	11/15 (Note 3)	22/15	209/25	1309/225	4	1	1.0	0.0	20	75
2	6/15	15/15	64	6/15	12/15	12/15	94/75	4	1	3.0	2.0	12	67
3	15/15	9/15	64	15/9	30/15	30/15	$\beta_{ed1}: 47/15$ $\beta_{ed2}: 47/15$	4 4	2	2.0	1.0	15	92
4	2/15	15/15	64	2/15	4/15	2/15	56/75	4	1	3.0	2.0	17	71
5	15/15 (Note 4)	15/15 (Note 4)	64	15/15 (Note 4)	30/15	24/15	134/15	4	1	1.0	0.0	21	81

Note 1: $\Delta_{ACK}, \Delta_{NACK}$ and $\Delta_{CQI} = 30/15$ with $\beta_{HS} = 30/15 * \beta_c$.

Note 2: CM = 1 for $\beta_c/\beta_d = 12/15$, $\beta_{HS}/\beta_c = 24/15$. For all other combinations of DPDCH, DPCCH, HS-DPCCH, E-DPDCH and E-DPCCH the MPR is based on the relative CM difference.

Note 3: For subtest 1 the β_c/β_d ratio of 11/15 for the TFC during the measurement period (TF1, TF0) is achieved by setting the signalled gain factors for the reference TFC (TF1, TF1) to $\beta_c = 10/15$ and $\beta_d = 15/15$.

Note 4: For subtest 5 the β_c/β_d ratio of 15/15 for the TFC during the measurement period (TF1, TF0) is achieved by setting the signalled gain factors for the reference TFC (TF1, TF1) to $\beta_c = 14/15$ and $\beta_d = 15/15$.

Note 5: In case of testing by UE using E-DPDCH Physical Layer category 1, Sub-test 3 is omitted according to TS25.306 Table 5.1g.

Note 6: β_{ed} can not be set directly, it is set by Absolute Grant Value.

Setup Configuration



<WCDMA Conducted Power>

General Note:

1. Applying the subtest setup in Table C.11.1.3 of 3GPP TS 34.121-1 V9.1.0 to Rel. 6 HSPA.
2. SAR testing in AMR configuration is not required when the maximum average output of each RF channel for AMR 12.2Kbps is less than 0.25dB higher than that measured in RMC 12.2Kbps
3. It is expected by the manufacturer that MPR for some HSDPA/HSUPA subtests may differ from the specification of 3GPP, according to the chipset implementation in this model. The implementation and expected deviation are detailed in tune-up procedure exhibit.
4. Per KDB 941225 D02v02r02, RMC 12.2kbps setting is used to evaluate SAR. If HSDPA/HSUPA output power is < 0.25dB higher than RMC, or reported SAR with RMC 12.2kbps setting is $\leq 1.2W/kg$, HSDPA/HSUPA SAR evaluation can be excluded.

Maximum Average RF Power (Proximity Sensor Inactive)

Band			WCDMA V			WCDMA II		
TX Channel			4132	4182	4233	9262	9400	9538
Rx Channel			4357	4407	4458	9662	9800	9938
Frequency (MHz)			826.4	836.4	846.6	1852.4	1880	1907.6
MPR (dB)	3GPP Rel 99	AMR 12.2Kbps	21.36	21.65	21.54	21.50	21.43	21.26
	3GPP Rel 99	RMC 12.2Kbps	21.40	21.68	21.58	21.52	21.46	21.27
0	3GPP Rel 6	HSDPA Subtest-1	20.91	21.13	21.09	21.13	21.06	20.98
0	3GPP Rel 6	HSDPA Subtest-2	20.89	21.07	20.96	21.11	21.03	20.96
0.5	3GPP Rel 6	HSDPA Subtest-3	20.68	20.82	20.71	21.06	20.94	20.89
0.5	3GPP Rel 6	HSDPA Subtest-4	20.57	20.77	20.69	20.96	20.93	20.87
0	3GPP Rel 6	HSUPA Subtest-1	20.87	21.09	20.95	20.89	20.76	20.68
2	3GPP Rel 6	HSUPA Subtest-2	20.41	20.83	20.64	20.66	20.41	20.35
1	3GPP Rel 6	HSUPA Subtest-3	20.68	20.97	20.79	20.73	20.62	20.55
2	3GPP Rel 6	HSUPA Subtest-4	20.49	20.88	20.56	20.67	20.46	20.33
0	3GPP Rel 6	HSUPA Subtest-5	20.77	20.98	20.86	20.79	20.66	20.57

Reduced Average RF Power (Proximity Sensor active)

Band			WCDMA V			WCDMA II		
TX Channel			4132	4182	4233	9262	9400	9538
Rx Channel			4357	4407	4458	9662	9800	9938
Frequency (MHz)			826.4	836.4	846.6	1852.4	1880	1907.6
MPR (dB)	3GPP Rel 99	AMR 12.2Kbps	16.44	16.73	16.43	16.48	16.45	16.31
	3GPP Rel 99	RMC 12.2Kbps	16.45	16.74	16.44	16.51	16.47	16.33
0	3GPP Rel 6	HSDPA Subtest-1	15.98	16.20	16.16	16.50	16.46	16.34
0	3GPP Rel 6	HSDPA Subtest-2	15.79	16.41	16.24	16.03	16.40	16.26
0.5	3GPP Rel 6	HSDPA Subtest-3	15.82	16.01	16.12	16.25	16.22	16.37
0.5	3GPP Rel 6	HSDPA Subtest-4	15.84	16.06	16.06	16.35	16.23	16.26
0	3GPP Rel 6	HSUPA Subtest-1	16.10	16.33	15.85	16.48	16.42	16.38
2	3GPP Rel 6	HSUPA Subtest-2	15.70	16.12	15.76	16.18	16.05	15.80
1	3GPP Rel 6	HSUPA Subtest-3	15.99	16.51	16.19	15.97	15.95	15.75
2	3GPP Rel 6	HSUPA Subtest-4	15.81	16.30	16.04	16.05	16.06	16.03
0	3GPP Rel 6	HSUPA Subtest-5	16.14	16.55	16.52	16.04	16.03	15.84



<WLAN Conducted Power>

General Note:

1. Per KDB 248227 D01 v01r02, choose the highest output power channel to test SAR and determine further SAR exclusion.
2. For each frequency band, testing at higher data rates and higher order modulations is not required when the maximum average output power for each of these configurations is less than 1/4dB higher than those measured at the lowest data rate.
3. Following KDB 248227 D01 v01r02, 802.11g, 802.11n-HT20 and 802.11n-HT40 output power is less than 1/4dB higher than 11b mode, thus the SAR can be excluded.

WLAN 2.4GHz 802.11b Average Power (dBm)					
Power vs. Channel			Power vs. Data Rate		
Channel	Frequency (MHz)	Data Rate	2Mbps	5.5Mbps	11Mbps
		1Mbps			
CH 1	2412	11.64	12.35	12.42	12.32
CH 6	2437	11.91			
CH 11	2462	12.43			

WLAN 2.4GHz 802.11g Average Power (dBm)									
Power vs. Channel			Power vs. Data Rate						
Channel	Frequency (MHz)	Data Rate	9Mbps	12Mbps	18Mbps	24Mbps	36Mbps	48Mbps	54Mbps
		6Mbps							
CH 1	2412	7.73	8.44	8.29	8.28	8.24	8.37	8.36	8.41
CH 6	2437	8.05							
CH 11	2462	8.46							

WLAN 2.4GHz 802.11n-HT20 Average Power (dBm)									
Power vs. Channel			Power vs. MCS Index						
Channel	Frequency (MHz)	MCS Index	MCS1	MCS2	MCS3	MCS4	MCS5	MCS6	MCS7
		MCS0							
CH 1	2412	6.78	7.52	7.54	7.56	7.55	7.47	7.40	7.40
CH 6	2437	7.16							
CH 11	2462	7.59							

WLAN 2.4GHz 802.11n-HT40 Average Power (dBm)									
Power vs. Channel			Power vs. MCS Index						
Channel	Frequency (MHz)	MCS Index	MCS1	MCS2	MCS3	MCS4	MCS5	MCS6	MCS7
		MCS0							
CH 3	2422	6.75	7.41	7.31	7.36	7.40	7.39	7.40	7.39
CH 6	2437	7.16							
CH 9	2452	7.42							



14. Bluetooth Exclusions Applied

Mode Band	Average power(dBm)	
	Bluetooth v3.0+EDR	Bluetooth v4.0 LE
2.4GHz Bluetooth	3	-5

Note:

1. Per KDB 447498 D01v05r02, the 1-g and 10-g SAR test exclusion thresholds for 100 MHz to 6 GHz at *test separation distances* ≤ 50 mm are determined by:

$$[(\text{max. power of channel, including tune-up tolerance, mW}) / (\text{min. test separation distance, mm})] \cdot [\sqrt{f(\text{GHz})}] \leq 3.0 \text{ for 1-g SAR and } \leq 7.5 \text{ for 10-g extremity SAR}$$

- f(GHz) is the RF channel transmit frequency in GHz
- Power and distance are rounded to the nearest mW and mm before calculation
- The result is rounded to one decimal place for comparison

Bluetooth Max Power (dBm)	Separation Distance (mm)	Frequency (GHz)	exclusion thresholds
3	0	2.48	0.63

Note: Per KDB 447498 D01v05r02, when the minimum test separation distance is < 5 mm, a distance of 5 mm is applied to determine SAR test exclusion. The test exclusion threshold is 0.63 which is ≤ 3, SAR testing is not required.

15. Antenna Location

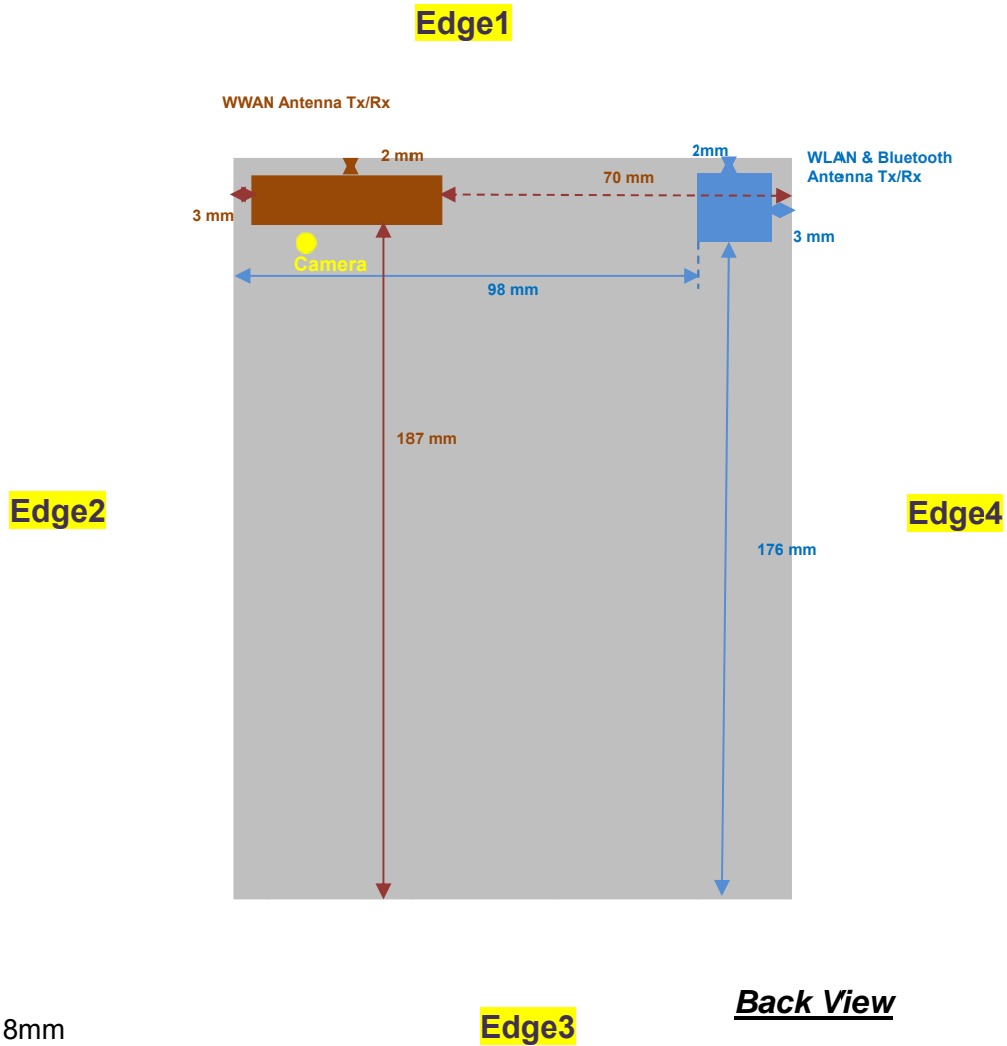



General Note:

1. Above the table, when the distance is < 50 mm exclusion threshold is "Ratio", when the distance is > 50 mm exclusion threshold is "mW"
2. Maximum power is the source-based time-average power and represents the maximum RF output power among production units
3. Per KDB 447498 D01v05r02, for larger devices, the test separation distance of adjacent edge configuration is determined by the closest separation between the antenna and the user.
4. Per KDB 447498 D01v05r02, standalone SAR test exclusion threshold is applied; If the test separation distance is < 5mm, 5mm is used to determine SAR exclusion threshold.
5. Per KDB 447498 D01v05r02, the 1-g and 10-g SAR test exclusion thresholds for 100 MHz to 6 GHz at *test separation distances* ≤ 50 mm are determined by:
 - [(max. power of channel, including tune-up tolerance, mW)/(min. test separation distance, mm)] · [√f(GHz)] ≤ 3.0 for 1-g SAR and ≤ 7.5 for 10-g extremity SAR
 - f(GHz) is the RF channel transmit frequency in GHz
 - Power and distance are rounded to the nearest mW and mm before calculation
 - The result is rounded to one decimal place for comparison
 - For < 50 mm distance, we just calculate mW of the exclusion threshold value (3.0) to do compare. This formula is $[3.0] / [\sqrt{f(\text{GHz})}] \cdot (\text{min. test separation distance, mm}) = \text{exclusion threshold of mW}$.
6. Per KDB 447498 D01v05r02, at 100 MHz to 6 GHz and for *test separation distances* > 50 mm, the SAR test exclusion threshold is determined according to the following
 - a) [Threshold at 50 mm in step 1) + (test separation distance - 50 mm) · (f(MHz)/150)] mW, at 100 MHz to 1500 MHz
 - b) [Threshold at 50 mm in step 1) + (test separation distance - 50 mm) · 10] mW at > 1500 MHz and ≤ 6 GHz

SAR test exclusion table distance is ≤ 50mm

Exposure Position	Wireless Interface	GPRS850 4Tx slots	GPRS1900 4 Tx slots	WCDMA Band V	WCDMA Band II	802.11b
		Tune-up Maximum power (dBm)	24.5	21.5	22.5	22.5
Bottom Face	Antenna to user (mm)	5				5
	SAR exclusion threshold	52	39	33	49	7
	SAR testing required?	Yes	Yes	Yes	Yes	Yes
Edge 1	Antenna to user (mm)	2				2
	SAR exclusion threshold	52	39	33	49	7
	SAR testing required?	Yes	Yes	Yes	Yes	Yes
Edge 2	Antenna to user (mm)	3				
	SAR exclusion threshold	52	39	33	49	
	SAR testing required?	Yes	Yes	Yes	Yes	
Edge 4	Antenna to user (mm)					3
	SAR exclusion threshold					7
	SAR testing required?					Yes

SAR test exclusion table distance is > 50mm

Exposure Position	Wireless Interface	GPRS850 4 Tx slots	GPRS1900 4 Tx slots	WCDMA Band V	WCDMA Band II	802.11b	
		Tune-up Maximum power (dBm)	24.5	21.5	22.5	22.5	13.5
		Tune-up Maximum rated power (mW)	282	141	178	178	22
Edge 2	Antenna to user (mm)					98	
	SAR exclusion threshold (mW)					576	
	SAR testing required?					No	
Edge 3	Antenna to user (mm)	187				176	
	SAR exclusion threshold (mW)	937	1479	936	1479	1356	
	SAR testing required?	No	No	No	No	No	
Edge 4	Antenna to user (mm)	70					
	SAR exclusion threshold (mW)	276	309	276	309		
	SAR testing required?	Yes	No	No	No		



16. SAR Test Results

General Note:

1. Per KDB 447498 D01v05r02, the reported SAR is the measured SAR value adjusted for maximum tune-up tolerance.
 - a. Tune-up scaling Factor = tune-up limit power (mW) / EUT RF power (mW), where tune-up limit is the maximum rated power among all production units.
 - b. Reported SAR(W/kg)= Measured SAR(W/kg)*Tune-up Scaling Factor
2. Per KDB 447498 D01v05r02, for each exposure position, testing of other required channels within the operating mode of a frequency band is not required when the *reported* 1-g or 10-g SAR for the mid-band or highest output power channel is:
 - ≤ 0.8 W/kg or 2.0 W/kg, for 1-g or 10-g respectively, when the transmission band is ≤ 100 MHz
 - ≤ 0.6 W/kg or 1.5 W/kg, for 1-g or 10-g respectively, when the transmission band is between 100 MHz and 200 MHz
 - ≤ 0.4 W/kg or 1.0 W/kg, for 1-g or 10-g respectively, when the transmission band is ≥ 200 MHz
3. Per KDB 941225 D02v02r02, RMC 12.2kbps setting is used to evaluate SAR. If HSDPA/HSUPA output power is < 0.25 dB higher than RMC, or reported SAR with RMC 12.2kbps setting is ≤ 1.2 W/kg, HSDPA/HSUPA SAR evaluation can be excluded.
4. For the exposure positions that proximity sensor power reduction is applied for SAR compliance, additional SAR testing with EUT transmitting full power in normal mode was performed; 9mm for bottom face, 4mm for edge1 and 4mm for edge2.
5. Curved region diagram of the device according to the appendix D test setup photo, X<Z, and Y<Z, Per KDB 616217 D04v01r01, curved SAR evaluation can be excluded.



16.1 Body SAR

<GSM SAR>

Plot No.	Band	Mode	Test Position	Gap (cm)	Ch.	Freq. (MHz)	Sample	Power Back-off	Average Power (dBm)	Tune-Up Limit (dBm)	Tune-up Scaling Factor	Power Drift (dB)	Measured 1g SAR (W/kg)	Reported 1g SAR (W/kg)
01	GSM850	GPRS(4 TX slots)	Bottom Face	0	251	848.8	#1	Sensor on	22.27	23	1.183	-0.06	0.629	0.744
	GSM850	GPRS(4 TX slots)	Edge 1	0	251	848.8	#1	Sensor on	22.27	23	1.183	0.05	0.341	0.403
	GSM850	GPRS(4 TX slots)	Edge 2	0	251	848.8	#1	Sensor on	22.27	23	1.183	0.13	0.114	0.135
	GSM850	GPRS(4 TX slots)	Bottom Face	0.9	251	848.8	#1	Sensor off	26.51	27.5	1.256	0.02	0.469	0.589
	GSM850	GPRS(4 TX slots)	Edge 1	0.4	251	848.8	#1	Sensor off	26.51	27.5	1.256	-0.01	0.467	0.587
	GSM850	GPRS(4 TX slots)	Edge 2	0.4	251	848.8	#1	Sensor off	26.51	27.5	1.256	0.02	0.173	0.217
	GSM850	GPRS(4 TX slots)	Edge 4	0	251	848.8	#1	Sensor off	26.51	27.5	1.256	-0.02	0.09	0.113
	GSM850	GPRS(4 TX slots)	Bottom Face	0	251	848.8	#2	Sensor on	22.27	23	1.183	-0.06	0.616	0.729
	GSM1900	GPRS(4 TX slots)	Bottom Face	0	810	1909.8	#1	Sensor on	19.38	20.5	1.294	0.11	0.695	0.899
	GSM1900	GPRS(4 TX slots)	Edge 1	0	810	1909.8	#1	Sensor on	19.38	20.5	1.294	0.02	0.528	0.683
	GSM1900	GPRS(4 TX slots)	Edge 2	0	810	1909.8	#1	Sensor on	19.38	20.5	1.294	-0.15	0.29	0.375
	GSM1900	GPRS(4 TX slots)	Bottom Face	0.9	810	1909.8	#1	Sensor off	23.31	24.5	1.315	0.14	0.349	0.459
02	GSM1900	GPRS(4 TX slots)	Edge 1	0.4	810	1909.8	#1	Sensor off	23.31	24.5	1.315	0.08	0.879	1.156
	GSM1900	GPRS(4 TX slots)	Edge 2	0.4	810	1909.8	#1	Sensor off	23.31	24.5	1.315	0.04	0.283	0.372
	GSM1900	GPRS(4 TX slots)	Bottom Face	0	512	1850.2	#1	Sensor on	18.97	20.5	1.422	0.08	0.574	0.816
	GSM1900	GPRS(4 TX slots)	Bottom Face	0	661	1880	#1	Sensor on	19.23	20.5	1.340	0.06	0.69	0.924
	GSM1900	GPRS(4 TX slots)	Edge 1	0.4	512	1850.2	#1	Sensor off	23.03	24.5	1.403	0.02	0.694	0.974
	GSM1900	GPRS(4 TX slots)	Edge 1	0.4	661	1880	#1	Sensor off	23.27	24.5	1.327	0.12	0.865	1.148
	GSM1900	GPRS(4 TX slots)	Edge 1	0.4	810	1909.8	#2	Sensor off	23.31	24.5	1.315	-0.03	0.791	1.040
	GSM1900	GPRS(4 TX slots)	Edge 1	0.4	512	1850.2	#2	Sensor off	23.03	24.5	1.403	0.02	0.581	0.815
	GSM1900	GPRS(4 TX slots)	Edge 1	0.4	661	1880	#2	Sensor off	23.27	24.5	1.327	0.03	0.725	0.962

<WCDMA SAR>

Plot No.	Band	Mode	Test Position	Gap (cm)	Ch.	Freq. (MHz)	Sample	Power Back-off	Average Power (dBm)	Tune-Up Limit (dBm)	Tune-up Scaling Factor	Power Drift (dB)	Measured 1g SAR (W/kg)	Reported 1g SAR (W/kg)
	WCDMA V	RMC 12.2K	Bottom Face	0	4182	836.4	#1	Sensor on	16.74	17.5	1.191	0.11	0.437	0.521
	WCDMA V	RMC 12.2K	Edge 1	0	4182	836.4	#1	Sensor on	16.74	17.5	1.191	0.08	0.169	0.201
	WCDMA V	RMC 12.2K	Edge 2	0	4182	836.4	#1	Sensor on	16.74	17.5	1.191	0.08	0.097	0.116
	WCDMA V	RMC 12.2K	Bottom Face	0.9	4182	836.4	#1	Sensor off	21.68	22.5	1.208	0.02	0.424	0.512
	WCDMA V	RMC 12.2K	Edge 1	0.4	4182	836.4	#1	Sensor off	21.68	22.5	1.208	0.03	0.326	0.394
	WCDMA V	RMC 12.2K	Edge 2	0.4	4182	836.4	#1	Sensor off	21.68	22.5	1.208	0.13	0.159	0.192
03	WCDMA V	RMC 12.2K	Bottom Face	0	4182	836.4	#2	Sensor on	16.74	17.5	1.191	-0.04	0.464	0.553
	WCDMA II	RMC 12.2K	Bottom Face	0	9262	1852.4	#1	Sensor on	16.51	17.5	1.256	0.08	0.651	0.818
	WCDMA II	RMC 12.2K	Edge 1	0	9262	1852.4	#1	Sensor on	16.51	17.5	1.256	0.06	0.497	0.624
	WCDMA II	RMC 12.2K	Edge 2	0	9262	1852.4	#1	Sensor on	16.51	17.5	1.256	-0.04	0.341	0.428
	WCDMA II	RMC 12.2K	Bottom Face	0.9	9262	1852.4	#1	Sensor off	21.52	22.5	1.253	-0.06	0.475	0.595
	WCDMA II	RMC 12.2K	Edge 1	0.4	9262	1852.4	#1	Sensor off	21.52	22.5	1.253	0.04	0.762	0.955
	WCDMA II	RMC 12.2K	Edge 2	0.4	9262	1852.4	#1	Sensor off	21.52	22.5	1.253	-0.06	0.468	0.586
	WCDMA II	RMC 12.2K	Bottom Face	0	9400	1880	#1	Sensor on	16.47	17.5	1.268	0.01	0.751	0.952
	WCDMA II	RMC 12.2K	Bottom Face	0	9538	1907.6	#1	Sensor on	16.33	17.5	1.309	0.06	0.72	0.943
	WCDMA II	RMC 12.2K	Edge 1	0.4	9400	1880	#1	Sensor off	21.46	22.5	1.271	-0.03	0.821	1.043
	WCDMA II	RMC 12.2K	Edge 1	0.4	9538	1907.6	#1	Sensor off	21.27	22.5	1.327	-0.03	0.727	0.965
04	WCDMA II	RMC 12.2K	Edge 1	0.4	9400	1880	#2	Sensor off	21.46	22.5	1.271	-0.01	0.828	1.052
	WCDMA II	RMC 12.2K	Edge 1	0.4	9262	1852.4	#2	Sensor off	21.52	22.5	1.253	0.03	0.724	0.907
	WCDMA II	RMC 12.2K	Edge 1	0.4	9538	1907.6	#2	Sensor off	21.27	22.5	1.327	-0.02	0.752	0.998



<DTS WLAN SAR>

Plot No.	Band	Mode	Test Position	Gap (cm)	Ch.	Freq. (MHz)	Data Rate (bps)	Sample	Average Power (dBm)	Tune-Up Limit (dBm)	Tune-up Scaling Factor	Power Drift (dB)	Measured 1g SAR (W/kg)	Reported 1g SAR (W/kg)
05	WLAN2.4G	802.11b	Bottom Face	0	11	2462	1M	#1	12.43	13.5	1.279	0.08	0.884	1.131
	WLAN2.4G	802.11b	Edge 1	0	11	2462	1M	#1	12.43	13.5	1.279	0.02	0.142	0.182
	WLAN2.4G	802.11b	Edge 4	0	11	2462	1M	#1	12.43	13.5	1.279	-0.09	0.328	0.420
	WLAN2.4G	802.11b	Bottom Face	0	1	2412	1M	#1	11.64	13	1.368	0.07	0.702	0.960
	WLAN2.4G	802.11b	Bottom Face	0	6	2437	1M	#1	11.91	13	1.285	0.07	0.841	1.081
	WLAN2.4G	802.11b	Bottom Face	0	11	2462	1M	#2	12.43	13.5	1.279	0.03	0.702	0.898
	WLAN2.4G	802.11b	Bottom Face	0	1	2412	1M	#2	11.64	13	1.368	-0.01	0.583	0.797
	WLAN2.4G	802.11b	Bottom Face	0	6	2437	1M	#2	11.91	13	1.285	0.04	0.621	0.798



16.2 Repeated SAR Measurement

No.	Band	Mode	Test Position	Gap (cm)	Ch.	Freq. (MHz)	Data Rate (bps)	Power Back-off	Average Power (dBm)	Tune-Up Limit (dBm)	Tune-up Scaling Factor	Power Drift (dB)	Measured 1g SAR (W/kg)	Ratio	Reported 1g SAR (W/kg)
1st	WLAN2.4G	802.11b	Bottom Face	0	11	2462	1M	-	12.43	13.5	1.279	0.08	0.884	1	1.131
2nd	WLAN2.4G	802.11b	Bottom Face	0	11	2462	1M	-	12.43	13.5	1.279	0.08	0.851	1.039	1.089
1st	GSM1900	GPRS(4 TX slots)	Edge 1	0.4	810	1909.8	-	Sensor off	23.31	24.5	1.315	0.08	0.879	1	1.156
2nd	GSM1900	GPRS(4 TX slots)	Edge 1	0.4	810	1909.8	-	Sensor off	23.31	24.5	1.315	-0.02	0.851	1.033	1.119

General Note:

1. Per KDB 865664 D01v01r03, for each frequency band, repeated SAR measurement is required only when the measured SAR is ≥ 0.8 W/kg
2. Per KDB 865664 D01v01r03, if the ratio among the repeated measurement is ≤ 1.2 and the measured SAR < 1.45 W/kg, only one repeated measurement is required.
3. The ratio is the difference in percentage between original and repeated *measured SAR*.
4. All measurement SAR result is scaled-up to account for tune-up tolerance and is compliant.



17. Simultaneous Transmission Analysis

NO.	Simultaneous Transmission Configurations	Tablet	Note
		Body	
1.	GPRS/EDGE(Data) + WLAN2.4GHz(data)	Yes	2.4GHz Hotspot
2.	WCDMA(Data) + WLAN2.4GHz(data)	Yes	2.4GHz Hotspot
3.	GPRS/EDGE(Data) + Bluetooth(data)	Yes	Bluetooth Tethering
4.	WCDMA(Data) + Bluetooth(data)	Yes	Bluetooth Tethering

General Note:

1. WLAN2.4GHz and Bluetooth share the same antenna, and cannot transmit simultaneously.
2. The Reported SAR summation is calculated based on the same configuration and test position.
3. Per KDB 447498 D01v05r02, simultaneous transmission SAR is compliant if,
 - i) Scalar SAR summation < 1.6W/kg.
 - ii) $SPLSR = (SAR_1 + SAR_2)^{1.5} / (min. \text{ separation distance, mm})$, and the peak separation distance is determined from the square root of $[(x_1-x_2)^2 + (y_1-y_2)^2 + (z_1-z_2)^2]$, where (x_1, y_1, z_1) and (x_2, y_2, z_2) are the coordinates of the extrapolated peak SAR locations in the zoom scan
 - iii) If $SPLSR \leq 0.04$, simultaneously transmission SAR measurement is not necessary
 - iv) Simultaneously transmission SAR measurement, and the reported multi-band SAR < 1.6W/kg
4. For simultaneous transmission analysis, Bluetooth SAR is estimated per KDB 447498 D01v05r02 based on the formula below.
 - i) $(max. \text{ power of channel, including tune-up tolerance, mW}) / (min. \text{ test separation distance, mm}) \cdot [\sqrt{f(\text{GHz})} / x] \text{ W/kg}$ for test separation distances $\leq 50 \text{ mm}$; where $x = 7.5$ for 1-g SAR, and $x = 18.75$ for 10-g SAR.
 - ii) When the minimum separation distance is < 5mm, the distance is used 5mm to determine SAR test exclusion.
 - iii) 0.4 W/kg for 1-g SAR and 1.0 W/kg for 10-g SAR, when the test separation distances is > 50 mm.
 - iv) Bluetooth estimated SAR is conservatively determined by 5mm separation, for all applicable exposure positions.

Bluetooth Max Power	Exposure Position	All Positions
3 dBm	Estimated SAR (W/kg)	0.084 W/kg



17.1 Body Accessory Exposure Conditions

< WWAN + WLAN >

WWAN Band		Exposure Position	WWAN	WLAN DTS	Summed SAR (W/kg)	SPLSR	Case No
			SAR (W/kg)	SAR (W/kg)			
GSM	GSM850	Bottom Face at 0 cm	0.744	1.131	1.88	0.04	01
		Edge 1 at 0 cm	0.403	0.182	0.59		
		Edge 2 at 0cm	0.135		0.14		
		Edge 4 at 0cm	0.113	0.42	0.53		
		Bottom Face at 0.9cm	0.589		0.59		
		Edge1 at 0.4cm	0.587		0.59		
		Edge2 at 0.4cm	0.217		0.22		
	GSM1900	Bottom Face at 0 cm	0.924	1.131	2.06	0.04	02
		Edge 1 at 0 cm	0.683	0.182	0.87		
		Edge 2 at 0cm	0.375		0.38		
		Edge 4 at 0cm		0.42	0.42		
		Bottom Face at 0.9cm	0.459		0.46		
		Edge1 at 0.4cm	1.156		1.16		
		Edge2 at 0.4cm	0.372		0.37		
WCMDA	Band V	Bottom Face at 0 cm	0.553	1.131	1.68	0.03	03
		Edge 1 at 0 cm	0.201	0.182	0.38		
		Edge 2 at 0cm	0.116		0.12		
		Edge 4 at 0cm		0.42	0.42		
		Bottom Face at 0.9cm	0.512		0.51		
		Edge1 at 0.4cm	0.394		0.39		
		Edge2 at 0.4cm	0.192		0.19		
	Band II	Bottom Face at 0 cm	0.952	1.131	2.08	0.04	04
		Edge 1 at 0 cm	0.624	0.182	0.81		
		Edge 2 at 0cm	0.428		0.43		
		Edge 4 at 0cm		0.42	0.42		
		Bottom Face at 0.9cm	0.595		0.60		
		Edge1 at 0.4cm	1.052		1.05		
		Edge2 at 0.4cm	0.586		0.59		



<WWAN + Bluetooth>

WWAN Band		Exposure Position	WWAN	Bluetooth DSS	Summed SAR (W/kg)	SPLSR	Case No
			SAR (W/kg)	Estimated SAR (W/kg)			
GSM	GSM850	Bottom Face at 0 cm	0.744	0.084	0.83		
		Edge 1 at 0 cm	0.403	0.084	0.49		
		Edge 2 at 0cm	0.135	0.084	0.22		
		Edge 4 at 0cm	0.113	0.084	0.20		
		Bottom Face at 0.9cm	0.589	0.084	0.67		
		Edge1 at 0.4cm	0.587	0.084	0.67		
	Edge2 at 0.4cm	0.217	0.084	0.30			
	GSM1900	Bottom Face at 0 cm	0.924	0.084	1.01		
		Edge 1 at 0 cm	0.683	0.084	0.77		
		Edge 2 at 0cm	0.375	0.084	0.46		
Bottom Face at 0.9cm		0.459	0.084	0.54			
Edge1 at 0.4cm		1.156	0.084	1.24			
Edge2 at 0.4cm	0.372	0.084	0.46				
WCMDA	Band V	Bottom Face at 0 cm	0.553	0.084	0.64		
		Edge 1 at 0 cm	0.201	0.084	0.29		
		Edge 2 at 0cm	0.116	0.084	0.20		
		Bottom Face at 0.9cm	0.512	0.084	0.60		
		Edge1 at 0.4cm	0.394	0.084	0.48		
		Edge2 at 0.4cm	0.192	0.084	0.28		
	Band II	Bottom Face at 0 cm	0.952	0.084	1.04		
		Edge 1 at 0 cm	0.624	0.084	0.71		
		Edge 2 at 0cm	0.428	0.084	0.51		
		Bottom Face at 0.9cm	0.595	0.084	0.68		
Edge1 at 0.4cm	1.052	0.084	1.14				
Edge2 at 0.4cm	0.586	0.084	0.67				

17.2 SPLSR Evaluation and Analysis

General Note:

1. For SPLSR calculation Bluetooth SAR peak position is estimated using WLAN 2.4GHz peak location, due to the WLAN and Bluetooth shares the same RF trace to the same antenna, and the operational frequency range is the same.
2. $SPLSR = (SAR_1 + SAR_2)^{1.5} / (min. \text{ separation distance, mm})$. If $SPLSR \leq 0.04$, simultaneously transmission SAR measurement is not necessary

Case No 01	Band	SAR (W/kg)	Gap (cm)	SAR peak location (m)			3D distance (mm)	Pair SAR sum (W/kg)	SPLSR	Simultaneous SAR
				X	Y	Z				
Bottom Face	GSM850	0.744	0	-0.033	0.0925	-0.18	72.3	1.88	0.04	Not required
	WLAN2.4GHz	1.131	0	0.0382	0.0798	-0.18				

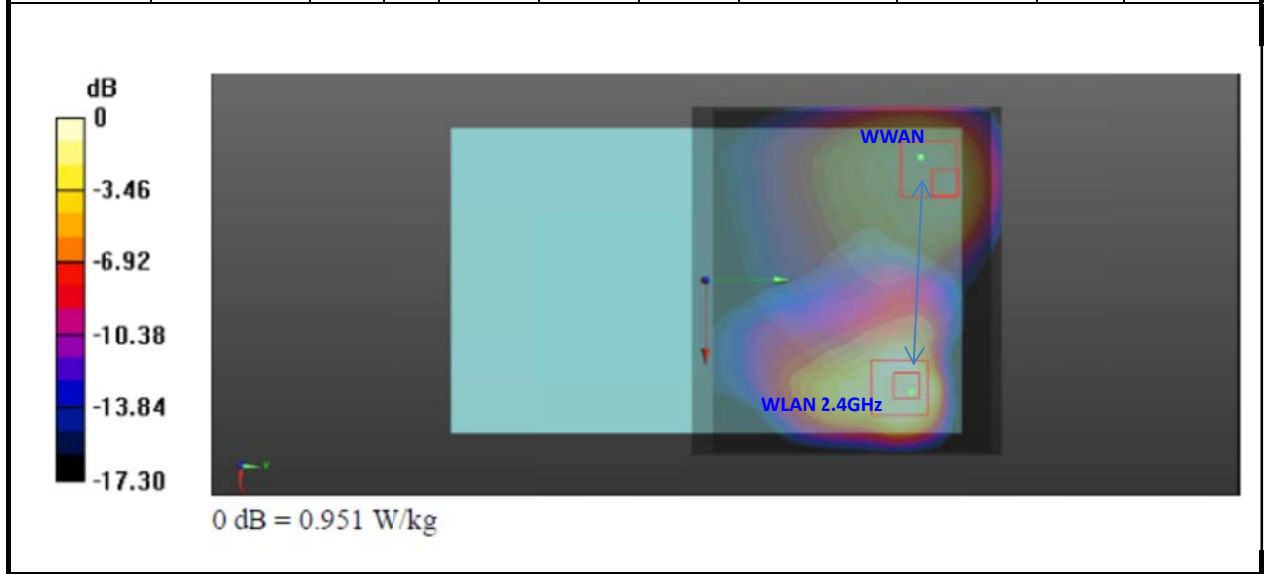

Case No 02	Band	SAR (W/kg)	Gap (cm)	SAR peak location (m)			3D distance (mm)	Pair SAR sum (W/kg)	SPLSR	Simultaneous SAR
				X	Y	Z				
Bottom Face	GSM1900	0.924	0	-0.0395	0.091	-0.179	78.5	2.06	0.04	Not required
	WLAN2.4GHz	1.131	0	0.0382	0.0798	-0.18				

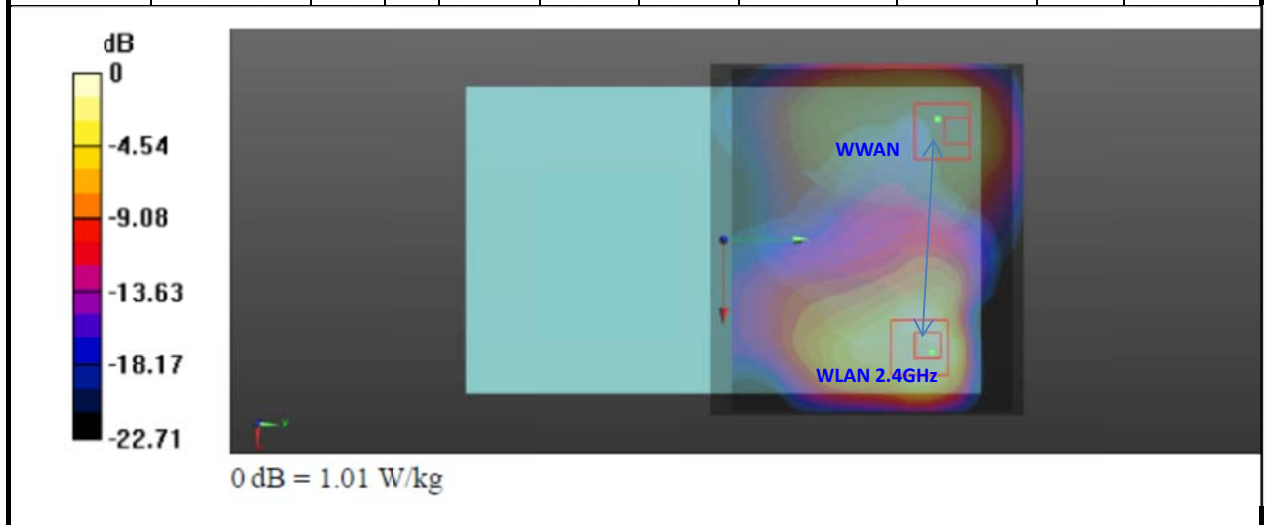

Case No 03	Band	SAR (W/kg)	Gap (cm)	SAR peak location (m)			3D distance (mm)	Pair SAR sum (W/kg)	SPLSR	Simultaneous SAR
				X	Y	Z				
Bottom Face	WCDMA Band V	0.553	0	-0.033	0.0925	-0.18	72.3	1.68	0.03	Not required
	WLAN2.4GHz	1.131	0	0.0382	0.0798	-0.18				

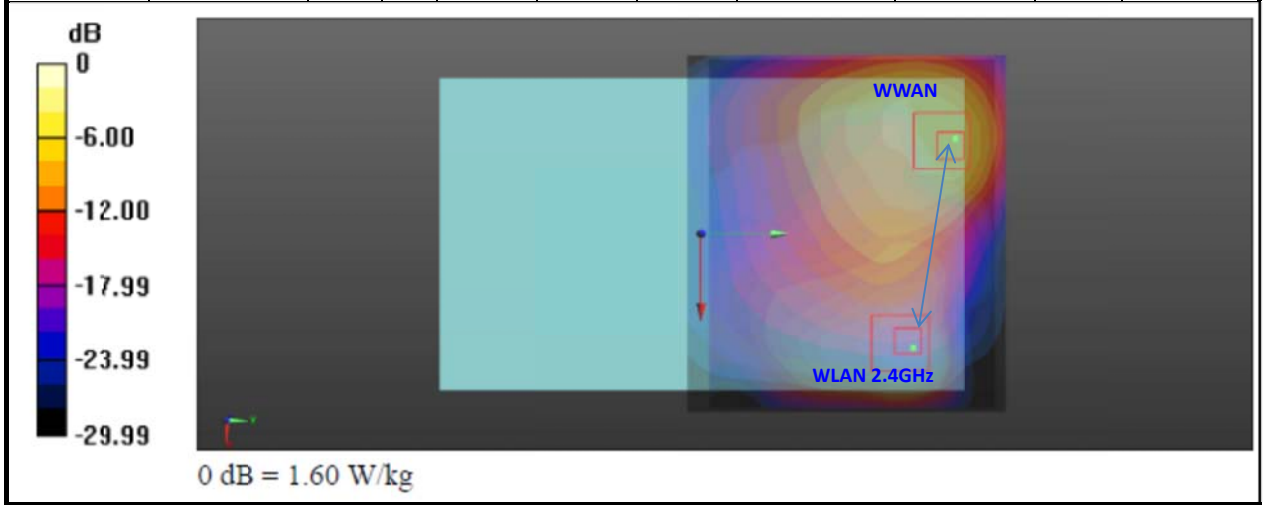

Case No 04	Band	SAR (W/kg)	Gap (cm)	SAR peak location (m)			3D distance (mm)	Pair SAR sum (W/kg)	SPLSR	Simultaneous SAR
				X	Y	Z				
Bottom Face	WCDMA Band II	0.952	0	-0.0395	0.091	-0.179	78.5	2.08	0.04	Not required
	WLAN2.4GHz	1.131	0	0.0382	0.0798	-0.18				

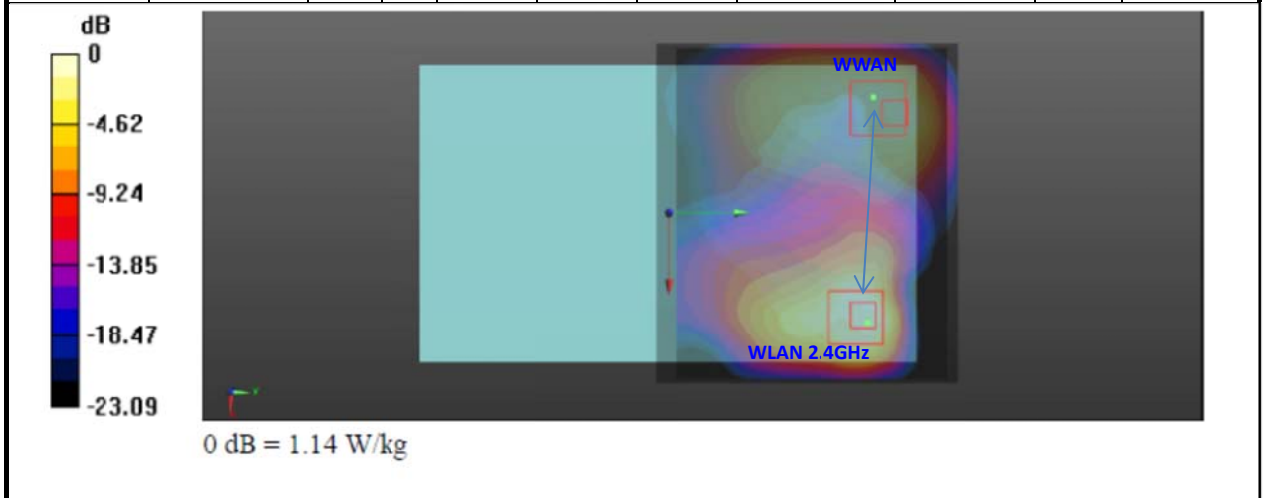

Test Engineer : Kat Yin

18. Uncertainty Assessment

The component of uncertainty may generally be categorized according to the methods used to evaluate them. The evaluation of uncertainty by the statistical analysis of a series of observations is termed a Type A evaluation of uncertainty. The evaluation of uncertainty by means other than the statistical analysis of a series of observation is termed a Type B evaluation of uncertainty. Each component of uncertainty, however evaluated, is represented by an estimated standard deviation, termed standard uncertainty, which is determined by the positive square root of the estimated variance.

A Type A evaluation of standard uncertainty may be based on any valid statistical method for treating data. This includes calculating the standard deviation of the mean of a series of independent observations; using the method of least squares to fit a curve to the data in order to estimate the parameter of the curve and their standard deviations; or carrying out an analysis of variance in order to identify and quantify random effects in certain kinds of measurement.

A type B evaluation of standard uncertainty is typically based on scientific judgment using all of the relevant information available. These may include previous measurement data, experience, and knowledge of the behavior and properties of relevant materials and instruments, manufacture’s specification, data provided in calibration reports and uncertainties assigned to reference data taken from handbooks. Broadly speaking, the uncertainty is either obtained from an outdoor source or obtained from an assumed distribution, such as the normal distribution, rectangular or triangular distributions indicated in table below.

Uncertainty Distributions	Normal	Rectangular	Triangular	U-Shape
Multi-plying Factor ^(a)	1/k ^(b)	1/√3	1/√6	1/√2

(a) standard uncertainty is determined as the product of the multiplying factor and the estimated range of variations in the measured quantity

(b) κ is the coverage factor

Table 18.1 Standard Uncertainty for Assumed Distribution

The combined standard uncertainty of the measurement result represents the estimated standard deviation of the result. It is obtained by combining the individual standard uncertainties of both Type A and Type B evaluation using the usual “root-sum-squares” (RSS) methods of combining standard deviations by taking the positive square root of the estimated variances.

Expanded uncertainty is a measure of uncertainty that defines an interval about the measurement result within which the measured value is confidently believed to lie. It is obtained by multiplying the combined standard uncertainty by a coverage factor. Typically, the coverage factor ranges from 2 to 3. Using a coverage factor allows the true value of a measured quantity to be specified with a defined probability within the specified uncertainty range. For purpose of this document, a coverage factor two is used, which corresponds to confidence interval of about 95 %. The DASY uncertainty Budget is shown in the following tables.



Error Description	Uncertainty Value (±%)	Probability Distribution	Divisor	Ci (1g)	Ci (10g)	Standard Uncertainty (1g)	Standard Uncertainty (10g)
Measurement System							
Probe Calibration	6.0	Normal	1	1	1	± 6.0 %	± 6.0 %
Axial Isotropy	4.7	Rectangular	√3	0.7	0.7	± 1.9 %	± 1.9 %
Hemispherical Isotropy	9.6	Rectangular	√3	0.7	0.7	± 3.9 %	± 3.9 %
Boundary Effects	1.0	Rectangular	√3	1	1	± 0.6 %	± 0.6 %
Linearity	4.7	Rectangular	√3	1	1	± 2.7 %	± 2.7 %
System Detection Limits	1.0	Rectangular	√3	1	1	± 0.6 %	± 0.6 %
Readout Electronics	0.3	Normal	1	1	1	± 0.3 %	± 0.3 %
Response Time	0.8	Rectangular	√3	1	1	± 0.5 %	± 0.5 %
Integration Time	2.6	Rectangular	√3	1	1	± 1.5 %	± 1.5 %
RF Ambient Noise	3.0	Rectangular	√3	1	1	± 1.7 %	± 1.7 %
RF Ambient Reflections	3.0	Rectangular	√3	1	1	± 1.7 %	± 1.7 %
Probe Positioner	0.4	Rectangular	√3	1	1	± 0.2 %	± 0.2 %
Probe Positioning	2.9	Rectangular	√3	1	1	± 1.7 %	± 1.7 %
Max. SAR Eval.	1.0	Rectangular	√3	1	1	± 0.6 %	± 0.6 %
Test Sample Related							
Device Positioning	2.9	Normal	1	1	1	± 2.9 %	± 2.9 %
Device Holder	3.6	Normal	1	1	1	± 3.6 %	± 3.6 %
Power Drift	5.0	Rectangular	√3	1	1	± 2.9 %	± 2.9 %
Phantom and Setup							
Phantom Uncertainty	4.0	Rectangular	√3	1	1	± 2.3 %	± 2.3 %
Liquid Conductivity (Target)	5.0	Rectangular	√3	0.64	0.43	± 1.8 %	± 1.2 %
Liquid Conductivity (Meas.)	2.5	Normal	1	0.64	0.43	± 1.6 %	± 1.1 %
Liquid Permittivity (Target)	5.0	Rectangular	√3	0.6	0.49	± 1.7 %	± 1.4 %
Liquid Permittivity (Meas.)	2.5	Normal	1	0.6	0.49	± 1.5 %	± 1.2 %
Combined Standard Uncertainty						± 11.0 %	± 10.8 %
Coverage Factor for 95 %						K=2	
Expanded Uncertainty						± 22.0 %	± 21.5 %

Table 18.2 Uncertainty Budget for frequency range 300 MHz to 3 GHz



19. References

- [1] FCC 47 CFR Part 2 “Frequency Allocations and Radio Treaty Matters; General Rules and Regulations”
- [2] ANSI/IEEE Std. C95.1-1992, “IEEE Standard for Safety Levels with Respect to Human Exposure to Radio Frequency Electromagnetic Fields, 3 kHz to 300 GHz”, September 1992
- [3] IEEE Std. 1528-2003, “Recommended Practice for Determining the Peak Spatial-Average Specific Absorption Rate (SAR) in the Human Head from Wireless Communications Devices: Measurement Techniques”, December 2003
- [4] SPEAG DASY System Handbook
- [5] FCC KDB 248227 D01 v01r02, “SAR Measurement Procedures for 802.11 a/b/g Transmitters”, May 2007
- [6] FCC KDB 447498 D01 v05r02, “Mobile and Portable Device RF Exposure Procedures and Equipment Authorization Policies”, Feb 2014
- [7] FCC KDB 941225 D01 v02, “SAR Measurement Procedures for 3G Devices – CDMA 2000 / Ev-Do / WCDMA / HSDPA / HSPA”, October 2007
- [8] FCC KDB 941225 D02 v02r02, “SAR Guidance for HSPA, HSPA+, DC-HSDPA and 1x-Advanced”, May 2013.
- [9] FCC KDB 941225 D03 v01, “Recommended SAR Test Reduction Procedures for GSM / GPRS / EDGE”, December 2008
- [10] FCC KDB 616217 D04 v01r01, “SAR Evaluation Considerations for Laptop, Notebook, Netbook and Tablet Computers”, May 2013
- [11] FCC KDB 865664 D01 v01r03, "SAR Measurement Requirements for 100 MHz to 6 GHz", Feb 2014.
- [12] FCC KDB 865664 D02 v01r01, “RF Exposure Compliance Reporting and Documentation Considerations” May 2013.



Appendix A. Plots of System Performance Check

The plots are shown as follows.

System Check_Body_835MHz_140515

DUT: Dipole 835 MHz D835V2

Communication System: CW; Frequency: 835 MHz; Duty Cycle: 1:1

Medium: MSL_835_140515 Medium parameters used: $f = 835 \text{ MHz}$; $\sigma = 0.975 \text{ S/m}$; $\epsilon_r = 54.261$; $\rho = 1000 \text{ kg/m}^3$

Ambient Temperature : $23.5 \text{ }^\circ\text{C}$; Liquid Temperature : $22.4 \text{ }^\circ\text{C}$

DASY5 Configuration:

- Probe: EX3DV4 - SN3898; ConvF(9.63, 9.63, 9.63); Calibrated: 2014/3/10;
- Sensor-Surface: 2mm (Mechanical Surface Detection)
- Electronics: DAE4 Sn1353; Calibrated: 2014/1/30
- Phantom: ELI v5.0; Type: QDOVA002AA; Serial: TP:1201
- Measurement SW: DASY52, Version 52.8 (5); SEMCAD X Version 14.6.8 (7028)

Pin=250mW/Area Scan (61x61x1): Interpolated grid: $dx=15\text{mm}$, $dy=15\text{mm}$
Maximum value of SAR (interpolated) = 2.45 W/kg

Pin=250mW/Zoom Scan (5x5x7)/Cube 0: Measurement grid: $dx=8\text{mm}$, $dy=8\text{mm}$, $dz=5\text{mm}$
Reference Value = 50.221 V/m ; Power Drift = 0.02 dB
Peak SAR (extrapolated) = 3.37 W/kg
SAR(1 g) = 2.28 W/kg ; SAR(10 g) = 1.51 W/kg
Maximum value of SAR (measured) = 2.47 W/kg

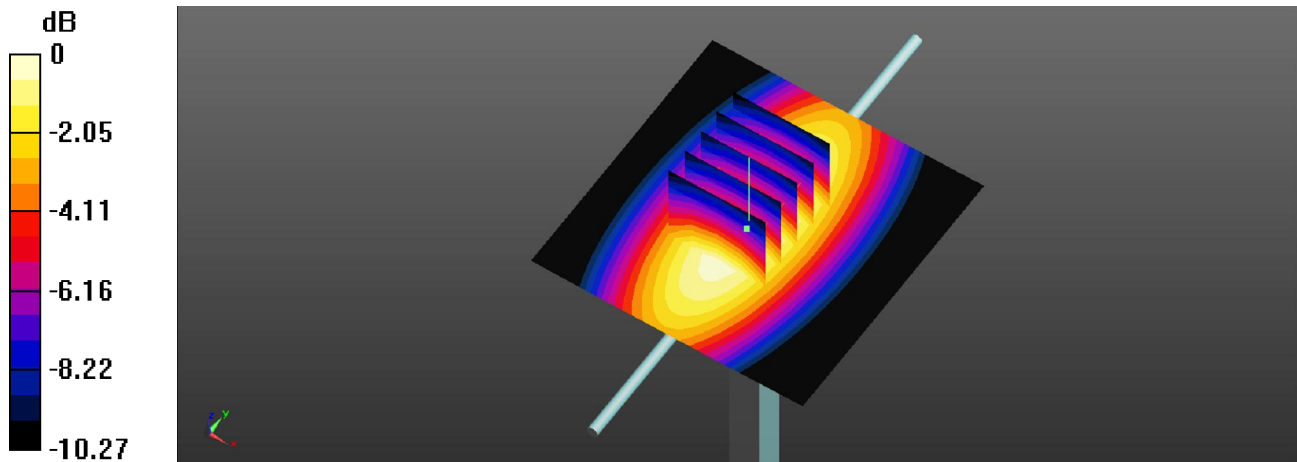

0 dB = 2.47 W/kg

System Check_Body_1900MHz_140420

DUT: Dipole 1900 MHz D1900V2

Communication System: CW; Frequency: 1900 MHz; Duty Cycle: 1:1

Medium: MSL_1900_140514 Medium parameters used: $f = 1900$ MHz; $\sigma = 1.501$ S/m; $\epsilon_r = 53.849$; $\rho = 1000$ kg/m³

Ambient Temperature : 23.5 °C ; Liquid Temperature : 22.5 °C

DASY5 Configuration:

- Probe: EX3DV4 - SN3898; ConvF(7.83, 7.83, 7.83); Calibrated: 2014/3/10;
- Sensor-Surface: 2mm (Mechanical Surface Detection)
- Electronics: DAE4 Sn1353; Calibrated: 2014/1/30
- Phantom: ELI v5.0; Type: QDOVA002AA; Serial: TP:1201
- Measurement SW: DASY52, Version 52.8 (5); SEMCAD X Version 14.6.8 (7028)

Pin=250mW/Area Scan (61x61x1): Interpolated grid: dx=15mm, dy=15mm
Maximum value of SAR (interpolated) = 14.6 W/kg

Pin=250mW/Zoom Scan (5x5x7)/Cube 0: Measurement grid: dx=8mm, dy=8mm, dz=5mm
Reference Value = 85.872 V/m; Power Drift = 0.04 dB
Peak SAR (extrapolated) = 18.6 W/kg
SAR(1 g) = 10.3 W/kg; SAR(10 g) = 5.32 W/kg
Maximum value of SAR (measured) = 14.7 W/kg

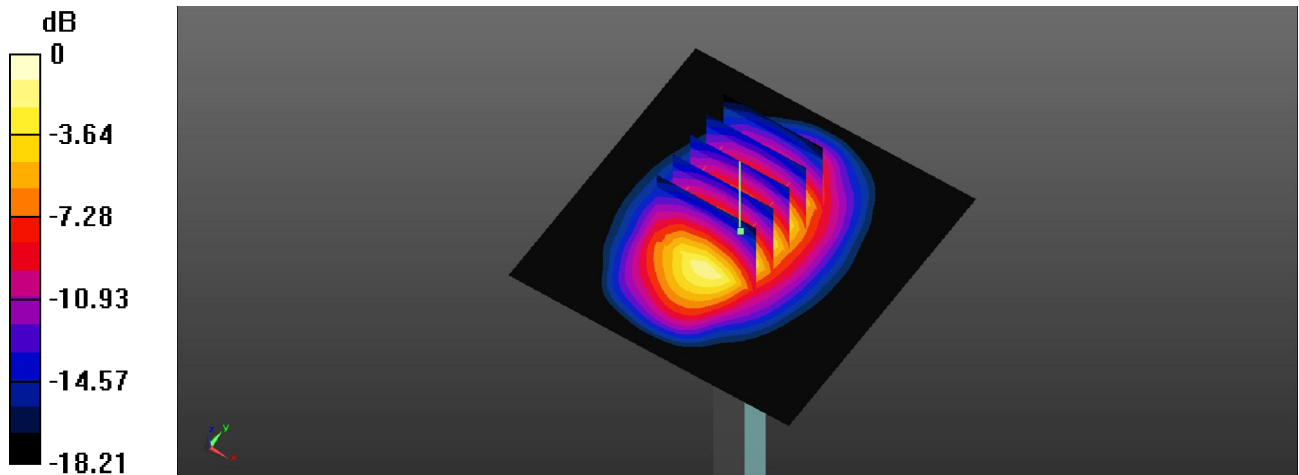

0 dB = 14.7 W/kg

System Check_Body_2450MHz_140522

DUT: Dipole 2450 MHz

Communication System: CW; Frequency: 2450 MHz; Duty Cycle: 1:1

Medium: MSL_2450_140522 Medium parameters used: $f = 2450$ MHz; $\sigma = 1.989$ S/m; $\epsilon_r = 51.267$; $\rho = 1000$ kg/m³

Ambient Temperature : 23.5 °C ; Liquid Temperature : 22.6 °C

DASY5 Configuration:

- Probe: EX3DV4 - SN3898; ConvF(7.49, 7.49, 7.49); Calibrated: 2014/3/10;
- Sensor-Surface: 2mm (Mechanical Surface Detection)
- Electronics: DAE4 Sn1353; Calibrated: 2014/1/30
- Phantom: ELI v5.0; Type: QDOVA002AA; Serial: TP:1201
- Measurement SW: DASY52, Version 52.8 (5); SEMCAD X Version 14.6.8 (7028)

Pin=250mW/Area Scan (91x91x1): Interpolated grid: dx=12mm, dy=12mm
Maximum value of SAR (interpolated) = 14.6 W/kg

Pin=250mW/Zoom Scan (7x7x7)/Cube 0: Measurement grid: dx=5mm, dy=5mm, dz=5mm
Reference Value = 83.062 V/m; Power Drift = 0.11 dB
Peak SAR (extrapolated) = 28.1 W/kg
SAR(1 g) = 12.8 W/kg; SAR(10 g) = 6.12 W/kg
Maximum value of SAR (measured) = 14.2 W/kg

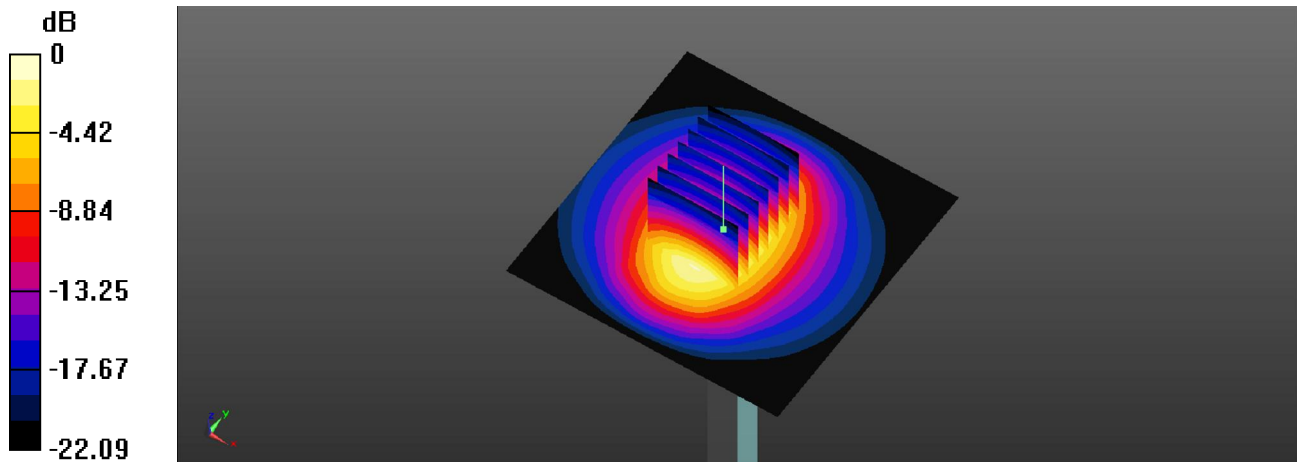

0 dB = 14.2 W/kg

System Check_Body_835MHz_140524

DUT: Dipole 835 MHz D835V2

Communication System: CW; Frequency: 835 MHz; Duty Cycle: 1:1

Medium: MSL_835_140524 Medium parameters used: $f = 835 \text{ MHz}$; $\sigma = 0.974 \text{ S/m}$; $\epsilon_r = 54.283$; $\rho = 1000 \text{ kg/m}^3$

Ambient Temperature : $23.5 \text{ }^\circ\text{C}$; Liquid Temperature : $22.5 \text{ }^\circ\text{C}$

DASY5 Configuration:

- Probe: EX3DV4 - SN3898; ConvF(9.63, 9.63, 9.63); Calibrated: 2014/3/10;
- Sensor-Surface: 2mm (Mechanical Surface Detection)
- Electronics: DAE4 Sn1353; Calibrated: 2014/1/30
- Phantom: ELI v5.0; Type: QDOVA002AA; Serial: TP:1201
- Measurement SW: DASY52, Version 52.8 (5); SEMCAD X Version 14.6.8 (7028)

Pin=250mW/Area Scan (61x61x1): Interpolated grid: $dx=15\text{mm}$, $dy=15\text{mm}$
Maximum value of SAR (interpolated) = 2.47 W/kg

Pin=250mW/Zoom Scan (5x5x7)/Cube 0: Measurement grid: $dx=8\text{mm}$, $dy=8\text{mm}$, $dz=5\text{mm}$
Reference Value = 50.121 V/m ; Power Drift = 0.01 dB
Peak SAR (extrapolated) = 3.31 W/kg
SAR(1 g) = 2.27 W/kg ; SAR(10 g) = 1.5 W/kg
Maximum value of SAR (measured) = 2.43 W/kg

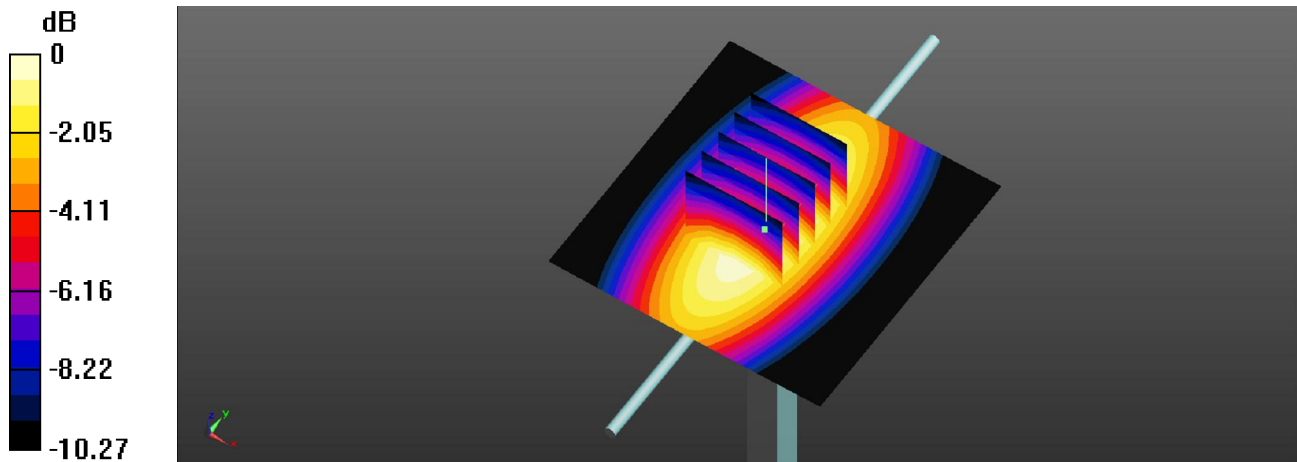

0 dB = 2.43 W/kg

System Check_Body_1900MHz_140524

DUT: Dipole 1900 MHz D1900V2

Communication System: CW; Frequency: 1900 MHz; Duty Cycle: 1:1

Medium: MSL_1900_140524 Medium parameters used: $f = 1900$ MHz; $\sigma = 1.519$ S/m; $\epsilon_r = 53.569$; $\rho = 1000$ kg/m³

Ambient Temperature : 23.5 °C ; Liquid Temperature : 22.5 °C

DASY5 Configuration:

- Probe: EX3DV4 - SN3898; ConvF(7.83, 7.83, 7.83); Calibrated: 2014/3/10;
- Sensor-Surface: 2mm (Mechanical Surface Detection)
- Electronics: DAE4 Sn1353; Calibrated: 2014/1/30
- Phantom: ELI v5.0; Type: QDOVA002AA; Serial: TP:1201
- Measurement SW: DASY52, Version 52.8 (5); SEMCAD X Version 14.6.8 (7028)

Pin=250mW/Area Scan (61x61x1): Interpolated grid: dx=15mm, dy=15mm
Maximum value of SAR (interpolated) = 14.76 W/kg

Pin=250mW/Zoom Scan (5x5x7)/Cube 0: Measurement grid: dx=8mm, dy=8mm, dz=5mm
Reference Value = 86.975 V/m; Power Drift = -0.03 dB
Peak SAR (extrapolated) = 18.7 W/kg
SAR(1 g) = 10.32 W/kg; SAR(10 g) = 5.32 W/kg
Maximum value of SAR (measured) = 14.8 W/kg

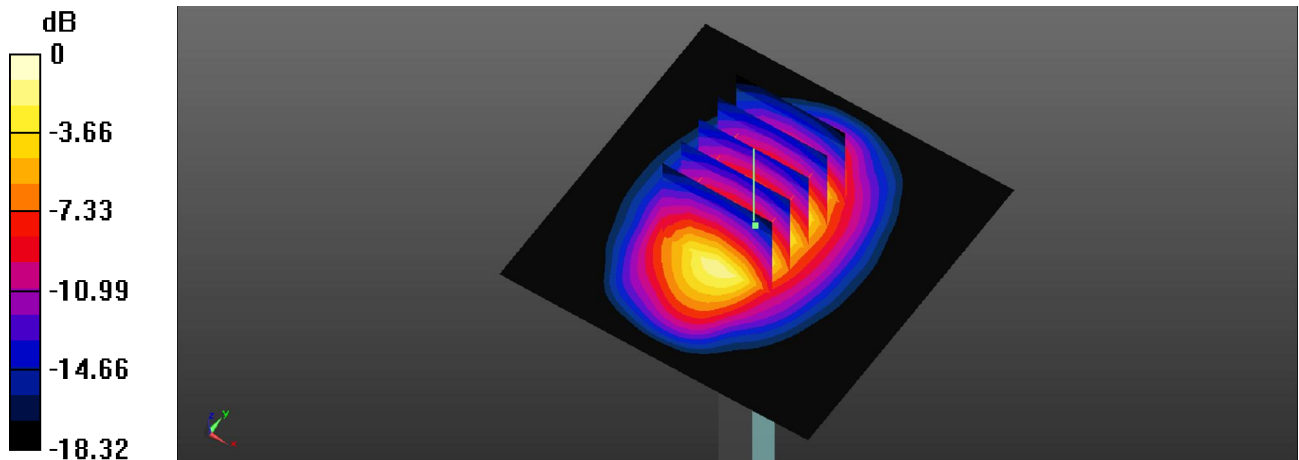

0 dB = 14.8 W/kg

System Check_Body_2450MHz_140524

DUT: Dipole 2450 MHz

Communication System: CW; Frequency: 2450 MHz; Duty Cycle: 1:1

Medium: MSL_2450_140526 Medium parameters used: $f = 2450$ MHz; $\sigma = 1.983$ S/m; $\epsilon_r = 51.159$; $\rho = 1000$ kg/m³

Ambient Temperature : 23.5 °C ; Liquid Temperature : 22.5 °C

DASY5 Configuration:

- Probe: EX3DV4 - SN3898; ConvF(7.49, 7.49, 7.49); Calibrated: 2014/3/10;
- Sensor-Surface: 2mm (Mechanical Surface Detection)
- Electronics: DAE4 Sn1353; Calibrated: 2014/1/30
- Phantom: ELI v5.0; Type: QDOVA002AA; Serial: TP:1201
- Measurement SW: DASY52, Version 52.8 (5); SEMCAD X Version 14.6.8 (7028)

Pin=250mW/Area Scan (91x91x1): Interpolated grid: dx=12mm, dy=12mm
Maximum value of SAR (interpolated) = 14.5 W/kg

Pin=250mW/Zoom Scan (7x7x7)/Cube 0: Measurement grid: dx=5mm, dy=5mm, dz=5mm
Reference Value = 83.062 V/m; Power Drift = 0.11 dB
Peak SAR (extrapolated) = 28.1 W/kg
SAR(1 g) = 12.8 W/kg; SAR(10 g) = 6.1 W/kg
Maximum value of SAR (measured) = 14.2 W/kg

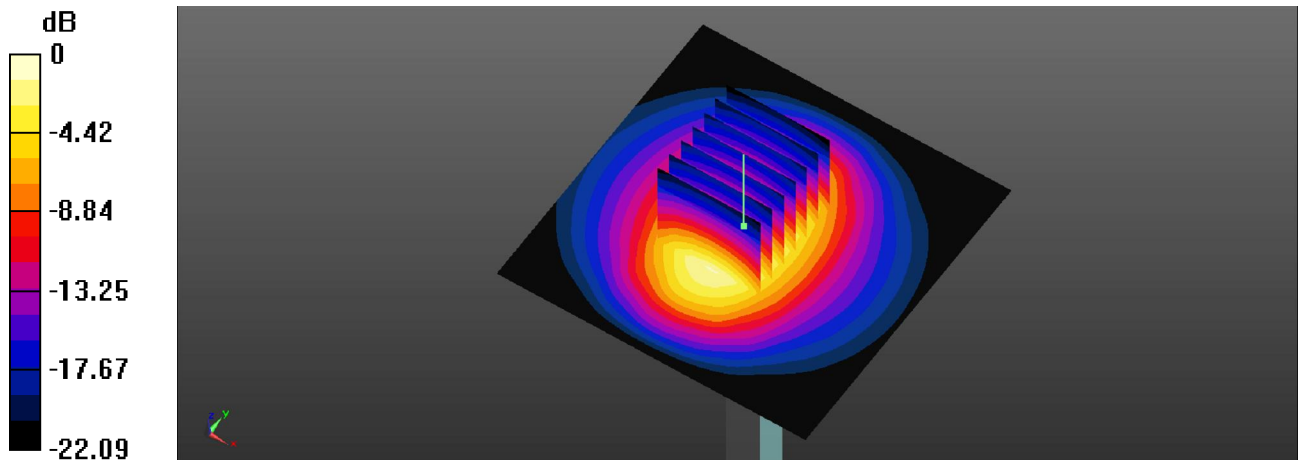

0 dB = 14.2 W/kg



Appendix B. Plots of High SAR Measurement

The plots are shown as follows.

01 GSM850_GPRS (GMSK 4 Tx slots)_Bottom Face_0cm_Ch251_Sensor on_Sample #1

Communication System: GPRS (GMSK 4 Tx slot); Frequency: 848.8 MHz; Duty Cycle: 1:2.08

Medium: MSL_835_140515 Medium parameters used: $f = 848.8$ MHz; $\sigma = 0.989$ S/m; $\epsilon_r = 54.136$; $\rho = 1000$ kg/m³

Ambient Temperature : 23.5 °C ; Liquid Temperature : 22.4 °C

DASY5 Configuration:

- Probe: EX3DV4 - SN3898; ConvF(9.63, 9.63, 9.63); Calibrated: 2014/3/10;
- Sensor-Surface: 2mm (Mechanical Surface Detection)
- Electronics: DAE4 Sn1353; Calibrated: 2014/1/30
- Phantom: ELI v5.0; Type: QDOVA002AA; Serial: TP:1201
- Measurement SW: DASY52, Version 52.8 (5); SEMCAD X Version 14.6.8 (7028)

Ch251/Area Scan (91x81x1): Interpolated grid: dx=15mm, dy=15mm

Maximum value of SAR (interpolated) = 0.789 W/kg

Ch251/Zoom Scan (5x5x7)/Cube 0: Measurement grid: dx=8mm, dy=8mm, dz=5mm

Reference Value = 3.114 V/m; Power Drift = -0.06 dB

Peak SAR (extrapolated) = 1.18 W/kg

SAR(1 g) = 0.629 W/kg; SAR(10 g) = 0.352 W/kg

Maximum value of SAR (measured) = 0.951 W/kg

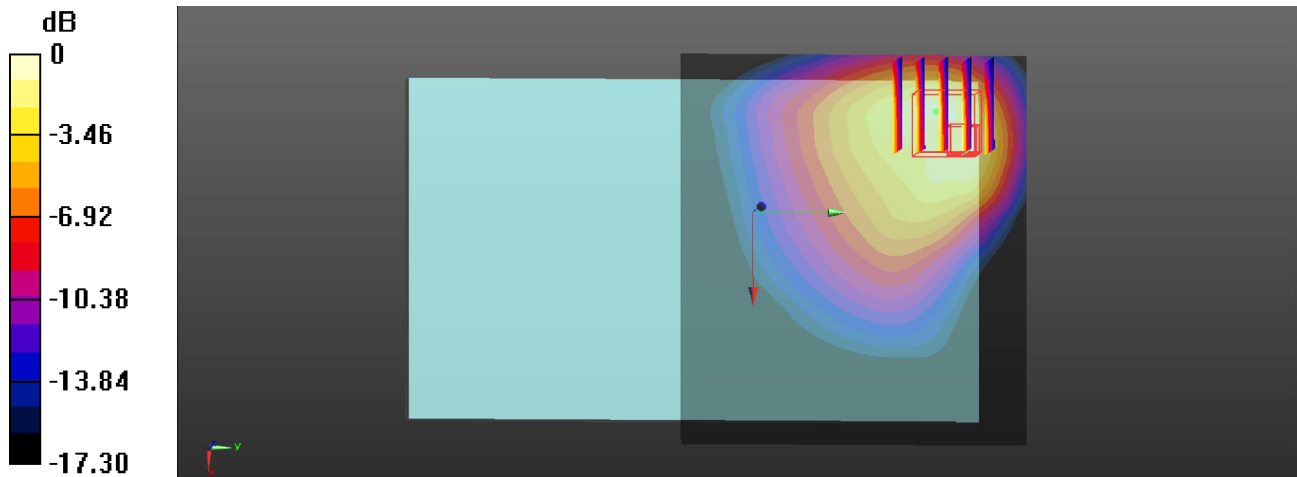

0 dB = 0.951 W/kg

02 GSM1900_GPRS (GMSK 4 Tx slots)_Edge 1_0.4cm_Ch810_Sensor off_Sample #1

Communication System: GPRS (GMSK 4 Tx slot); Frequency: 1909.8 MHz; Duty Cycle: 1:2.08
 Medium: MSL_1900_140514 Medium parameters used: $f = 1909.8$ MHz; $\sigma = 1.511$ S/m; $\epsilon_r = 53.819$; $\rho = 1000$ kg/m³
 Ambient Temperature : 23.5 °C ; Liquid Temperature : 22.5 °C

DASY5 Configuration:

- Probe: EX3DV4 - SN3898; ConvF(7.83, 7.83, 7.83); Calibrated: 2014/3/10;
- Sensor-Surface: 2mm (Mechanical Surface Detection)
- Electronics: DAE4 Sn1353; Calibrated: 2014/1/30
- Phantom: ELI v5.0; Type: QDOVA002AA; Serial: TP:1201
- Measurement SW: DASY52, Version 52.8 (5); SEMCAD X Version 14.6.8 (7028)

Ch810/Area Scan (31x101x1): Interpolated grid: dx=15mm, dy=15mm
 Maximum value of SAR (interpolated) = 0.993 W/kg

Ch810/Zoom Scan (5x5x7)/Cube 0: Measurement grid: dx=8mm, dy=8mm, dz=5mm
 Reference Value = 14.400 V/m; Power Drift = 0.08 dB
 Peak SAR (extrapolated) = 1.51 W/kg
SAR(1 g) = 0.879 W/kg; SAR(10 g) = 0.433 W/kg
 Maximum value of SAR (measured) = 1.27 W/kg

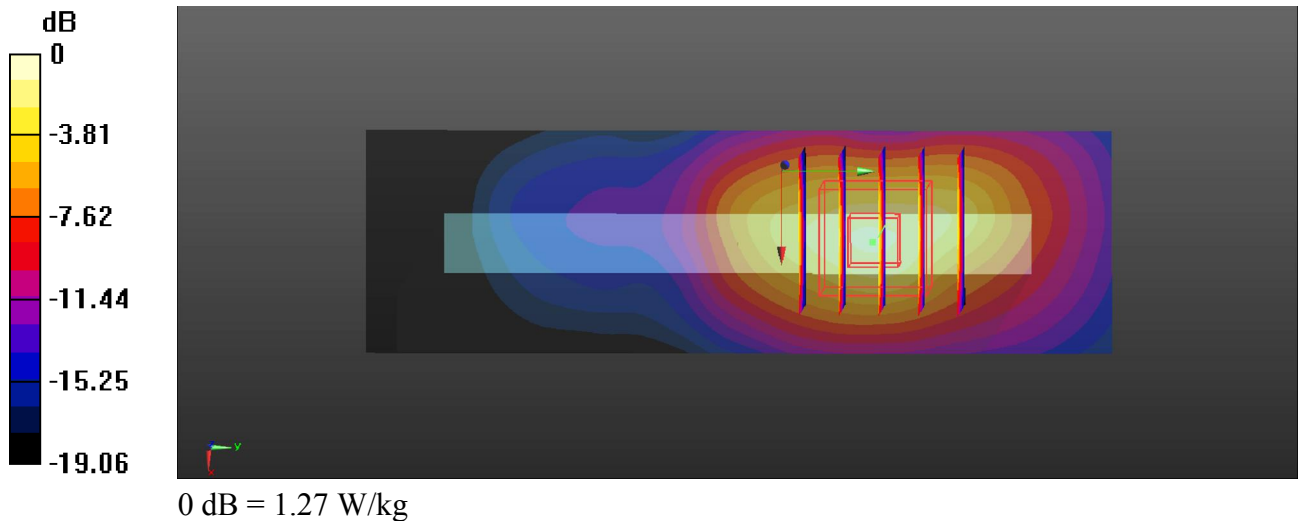

03 WCDMA V_RMC 12.2K_Bottom Face_0cm_Ch4182_Sensor on_Sample #2

Communication System: WCDMA ; Frequency: 836.4 MHz; Duty Cycle: 1:1

Medium: MSL_835_140524 Medium parameters used: $f = 836.4$ MHz; $\sigma = 0.976$ S/m; $\epsilon_r = 54.27$; $\rho = 1000$ kg/m³

Ambient Temperature : 23.5 °C ; Liquid Temperature : 22.5 °C

DASY5 Configuration:

- Probe: EX3DV4 - SN3898; ConvF(9.63, 9.63, 9.63); Calibrated: 2014/3/10;
- Sensor-Surface: 2mm (Mechanical Surface Detection)
- Electronics: DAE4 Sn1353; Calibrated: 2014/1/30
- Phantom: ELI v5.0; Type: QDOVA002AA; Serial: TP:1201
- Measurement SW: DASY52, Version 52.8 (5); SEMCAD X Version 14.6.8 (7028)

Ch4182/Area Scan (91x81x1): Interpolated grid: dx=15mm, dy=15mm

Maximum value of SAR (interpolated) = 0.633 W/kg

Ch4182/Zoom Scan (5x5x7)/Cube 0: Measurement grid: dx=8mm, dy=8mm, dz=5mm

Reference Value = 2.617 V/m; Power Drift = -0.04 dB

Peak SAR (extrapolated) = 0.858 W/kg

SAR(1 g) = 0.464 W/kg; SAR(10 g) = 0.274 W/kg

Maximum value of SAR (measured) = 0.646 W/kg

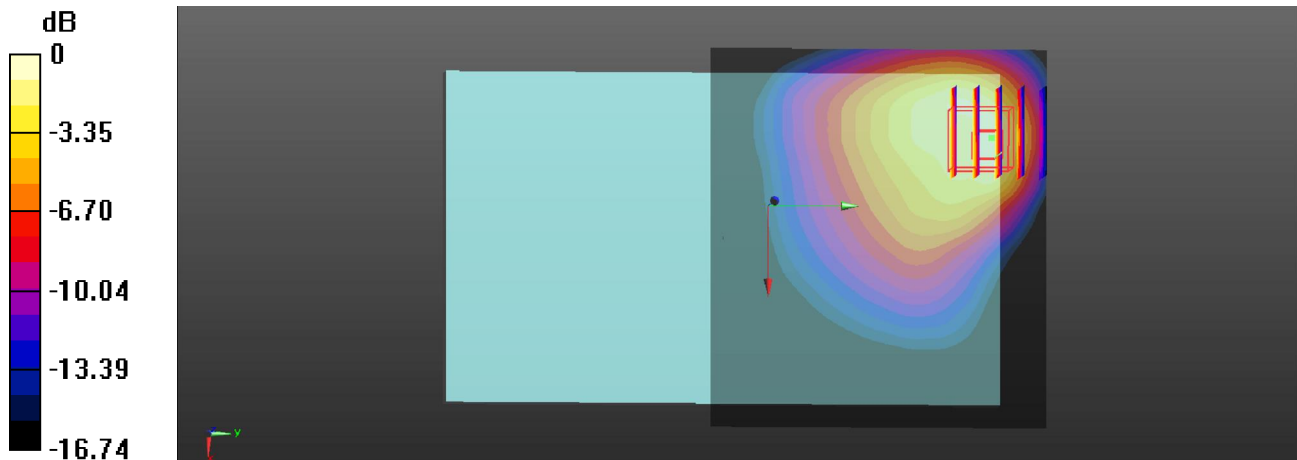

0 dB = 0.646 W/kg

04 WCDMA II_RMC 12.2K_Edge 1_0.4cm_Ch9400_Sensor off_Sample #2

Communication System: WCDMA ; Frequency: 1880 MHz;Duty Cycle: 1:1

Medium: MSL_1900_140524 Medium parameters used: $f = 1880$ MHz; $\sigma = 1.498$ S/m; $\epsilon_r = 53.575$; $\rho = 1000$ kg/m³

Ambient Temperature : 23.5 °C ; Liquid Temperature : 22.5 °C

DASY5 Configuration:

- Probe: EX3DV4 - SN3898; ConvF(7.83, 7.83, 7.83); Calibrated: 2014/3/10;
- Sensor-Surface: 2mm (Mechanical Surface Detection)
- Electronics: DAE4 Sn1353; Calibrated: 2014/1/30
- Phantom: ELI v5.0; Type: QDOVA002AA; Serial: TP:1201
- Measurement SW: DASY52, Version 52.8 (5); SEMCAD X Version 14.6.8 (7028)

Ch9400/Area Scan (31x101x1): Interpolated grid: dx=15mm, dy=15mm

Maximum value of SAR (interpolated) = 1.03 W/kg

Ch9400/Zoom Scan (5x5x7)/Cube 0: Measurement grid: dx=8mm, dy=8mm, dz=5mm

Reference Value = 17.534 V/m; Power Drift = -0.01 dB

Peak SAR (extrapolated) = 1.38 W/kg

SAR(1 g) = 0.828 W/kg; SAR(10 g) = 0.438 W/kg

Maximum value of SAR (measured) = 1.14 W/kg

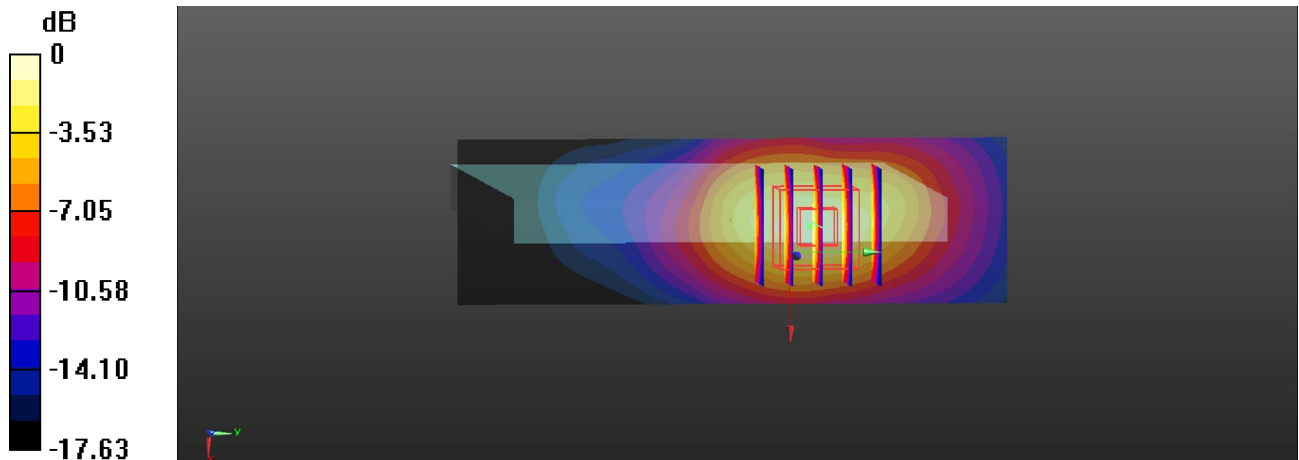

0 dB = 1.14 W/kg

05 WLAN 2.4G_802.11b_Bottom Face_0cm_Ch11_Sample #1

Communication System: 802.11b; Frequency: 2462 MHz; Duty Cycle: 1:1

Medium: MSL_2450_140522 Medium parameters used: $f = 2462$ MHz; $\sigma = 2.006$ S/m; $\epsilon_r = 51.221$; $\rho = 1000$ kg/m³

Ambient Temperature : 23.5 °C ; Liquid Temperature : 22.6 °C

DASY5 Configuration:

- Probe: EX3DV4 - SN3898; ConvF(7.49, 7.49, 7.49); Calibrated: 2014/3/10;
- Sensor-Surface: 2mm (Mechanical Surface Detection)
- Electronics: DAE4 Sn1353; Calibrated: 2014/1/30
- Phantom: ELI v5.0; Type: QDOVA002AA; Serial: TP:1201
- Measurement SW: DASY52, Version 52.8 (5); SEMCAD X Version 14.6.8 (7028)

Ch11/Area Scan (111x91x1): Interpolated grid: dx=12mm, dy=12mm

Maximum value of SAR (interpolated) = 1.38 W/kg

Ch11/Zoom Scan (7x7x7)/Cube 0: Measurement grid: dx=5mm, dy=5mm, dz=5mm

Reference Value = 1.740 V/m; Power Drift = 0.08 dB

Peak SAR (extrapolated) = 2.54 W/kg

SAR(1 g) = 0.884 W/kg; SAR(10 g) = 0.414 W/kg

Maximum value of SAR (measured) = 1.60 W/kg

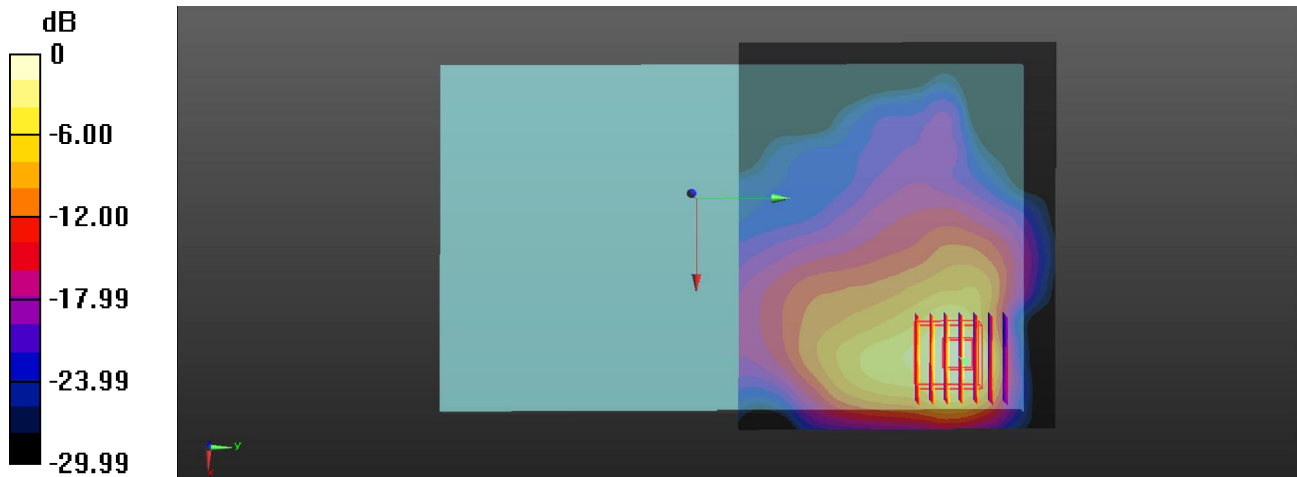

0 dB = 1.60 W/kg