

# ShenZhen QiXinTongDa Technology Co.,Ltd.

## Antenna Test Report

**Project Name:** KC240

**GSM:** B2/B3/B5/B8

**WCDMA:** B2/B4/B5/B8

**FDD:**B2/B3/B4/B5/B8/B12/B17/B28AB/B66

**DATE:** 2024-06-27

**ADDRESS:** Room503-505,Building211,

Tairan IndustrialandTradePark,Chegongmiao,FutianDistrict,Shenzhen

# 1. Test Project

	Test Project	Equipment
1. S Parameter	1. Return Loss (RL)  2. VSWR	Network Analyzer:  Agilent 5071B
2. RF Test  (2/3/4G)	1. power  2. level  3. TRP/TIS	Comprehensive Test:  SP9500/CMW500/8960  Test Environment:  Anechoic Chamber

# 2. Test Equipment



**Agilent 5071B** (S Parameter (RL/VSWR) Test Equipment)



Agilent 8960 (2G/3G Test Equipment)

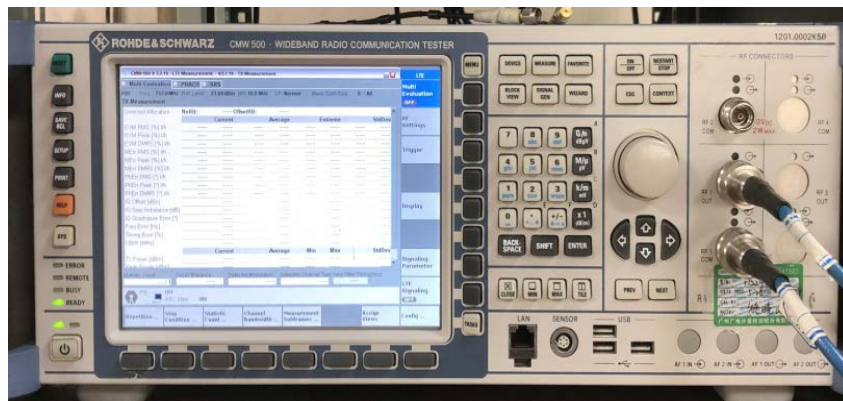

CMW 500 (2G/3G/4G Test Equipment)



SP9500 (5G Test Equipment)

### 3. TestEnvironment

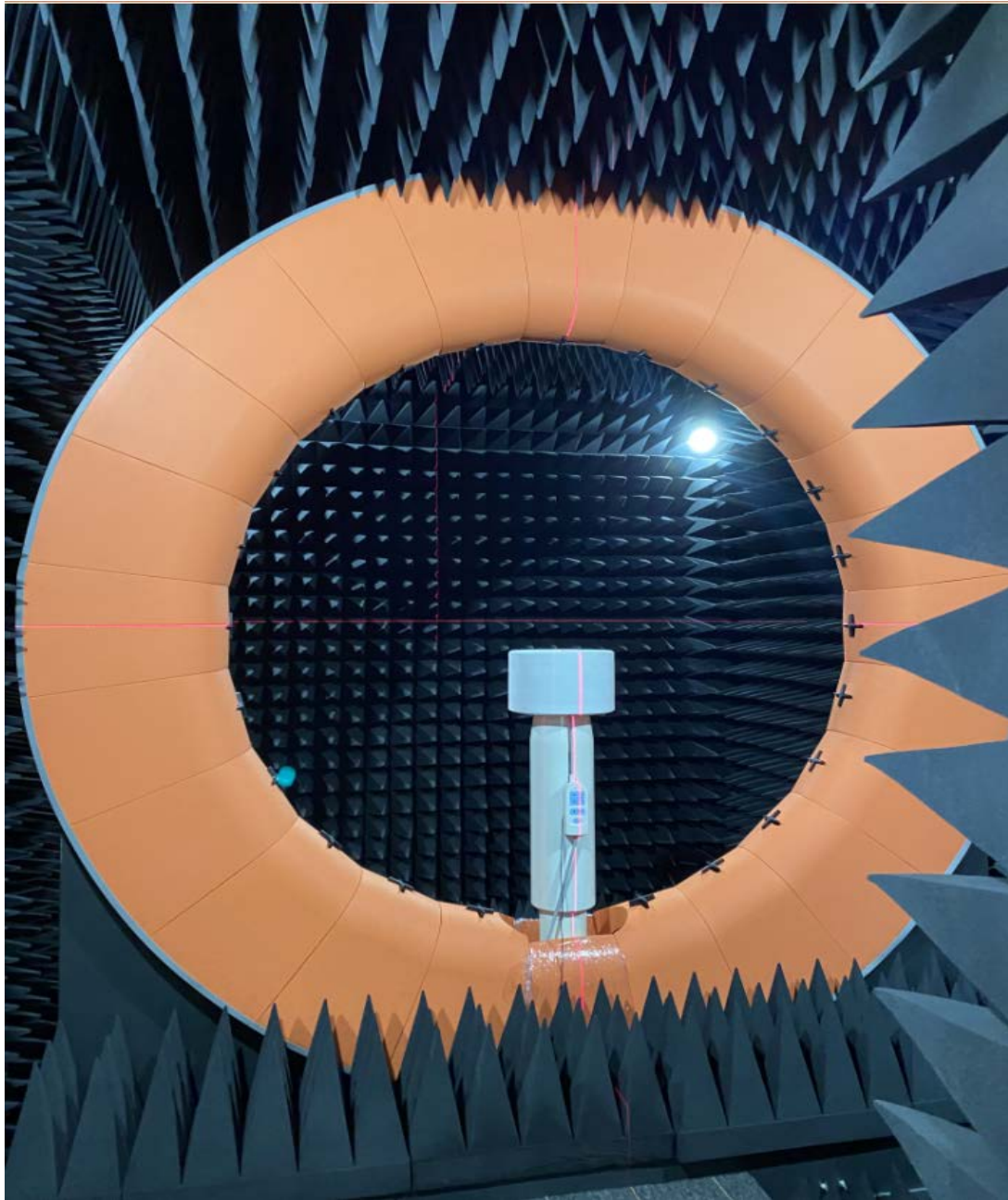

Microwave Anechoic Chamber

# 4. Test Steps

## Passive VSWR/RL Test Steps:

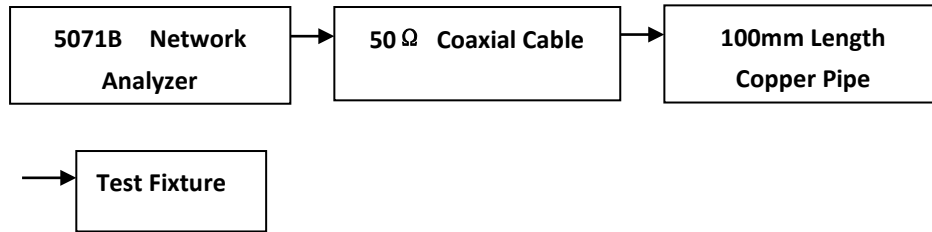

## Active TRP/TIS Test Steps:

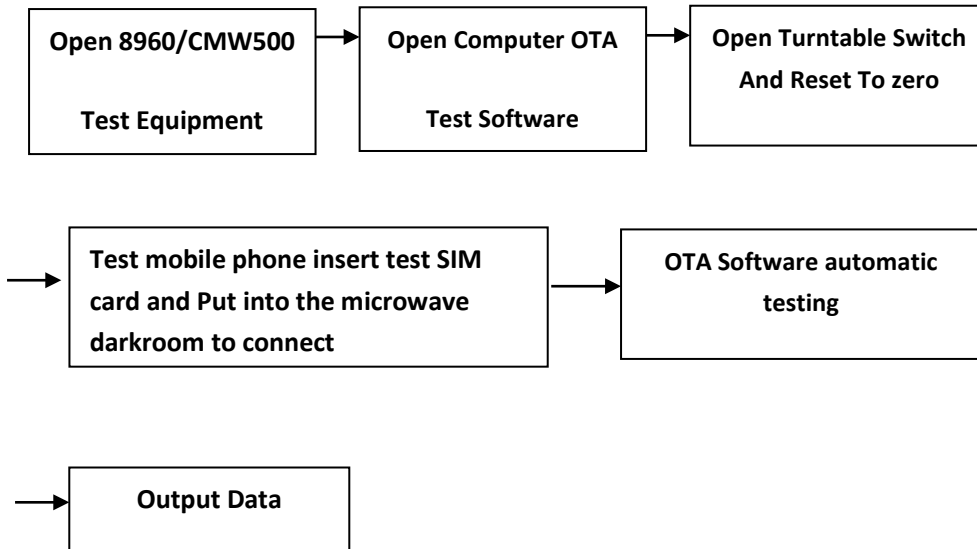

## 5. Antenna Gain

Band	Max Gain	Band	Max Gain
GSM850	0.11	LTE-B2	0.25
GSM900	0.14	LTE-B3	0.17
DCS1800	0.17	LTE-B4	0.21
PCS1900	0.25	LTE-B5	-0.32
WCDMA2	0.25	LTE-B8	0.11
WCDMA4	0.21	LTE-B12	-0.22
WCDMA5	0.11	LTE-B17	-0.41
WCDMA8	0.14	LTE-B28A	-0.39
		LTE-B28B	-0.40
Bluetooth	0.11	LTE-B66	0.21

# 6.3D Lobe Diagram

GSM850

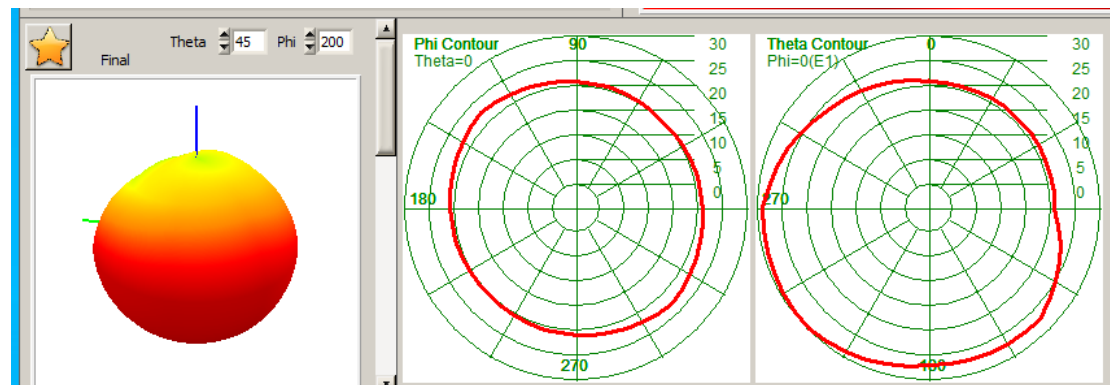

GSM900

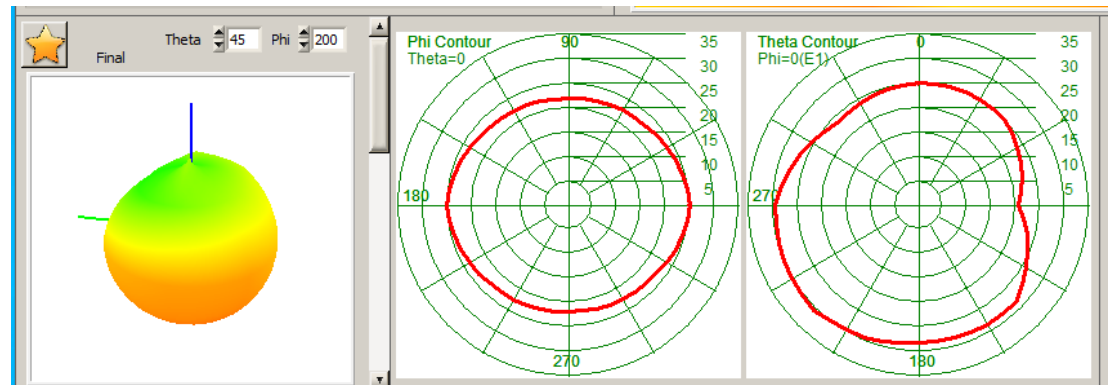

DSC1800

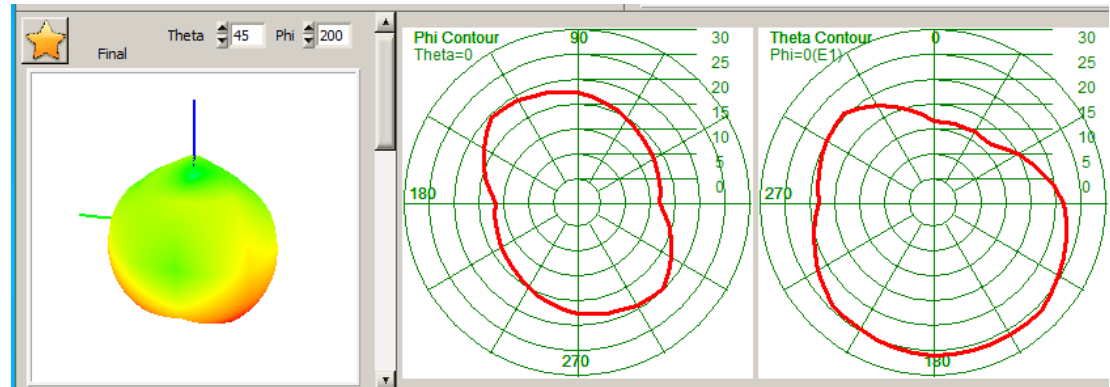

PCS1900



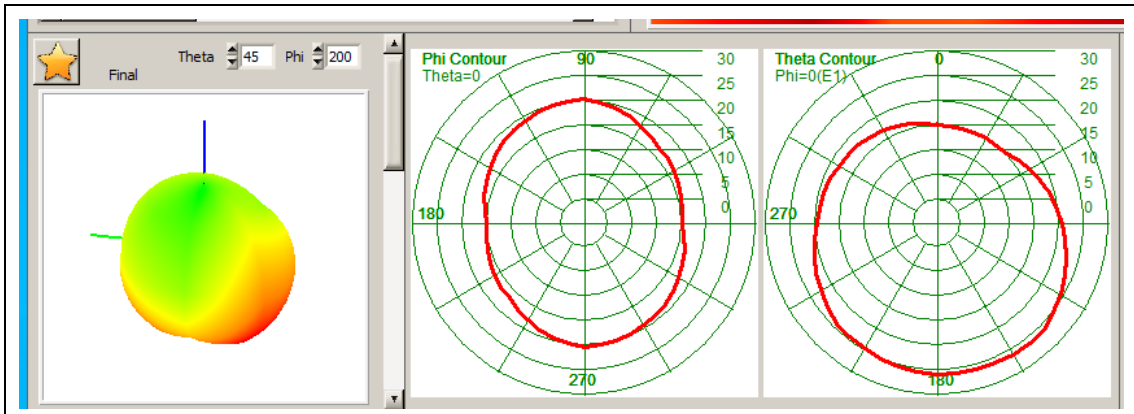

W2

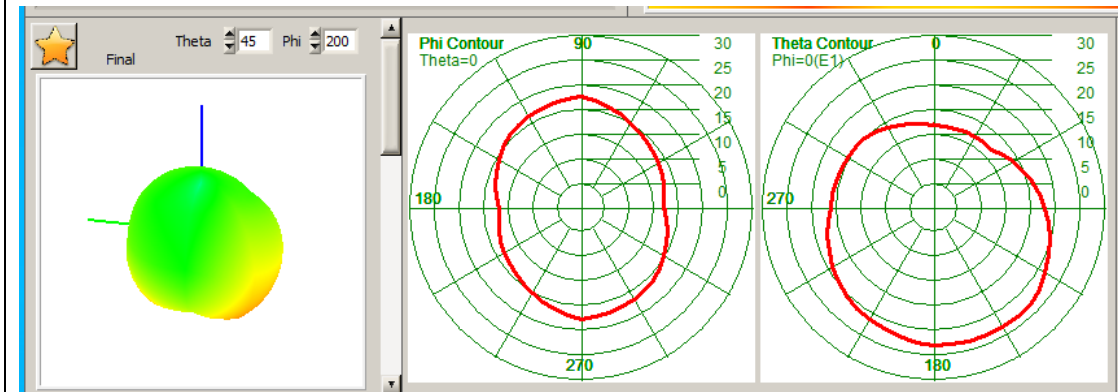

W4

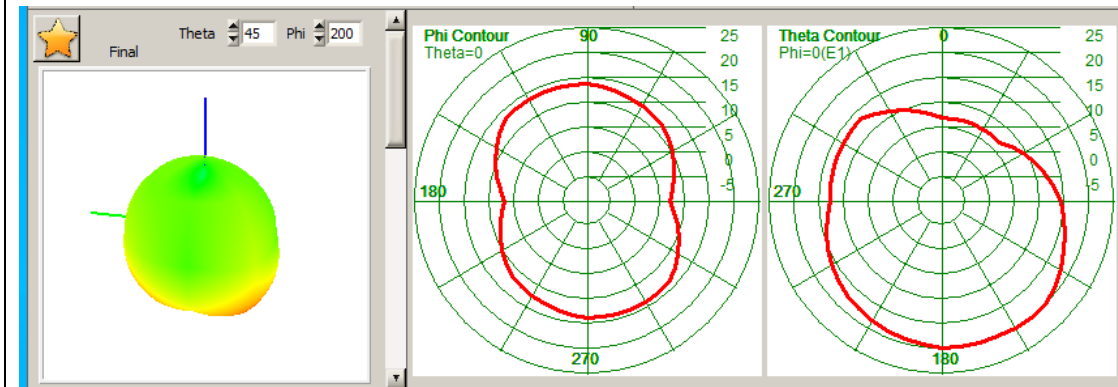

W5

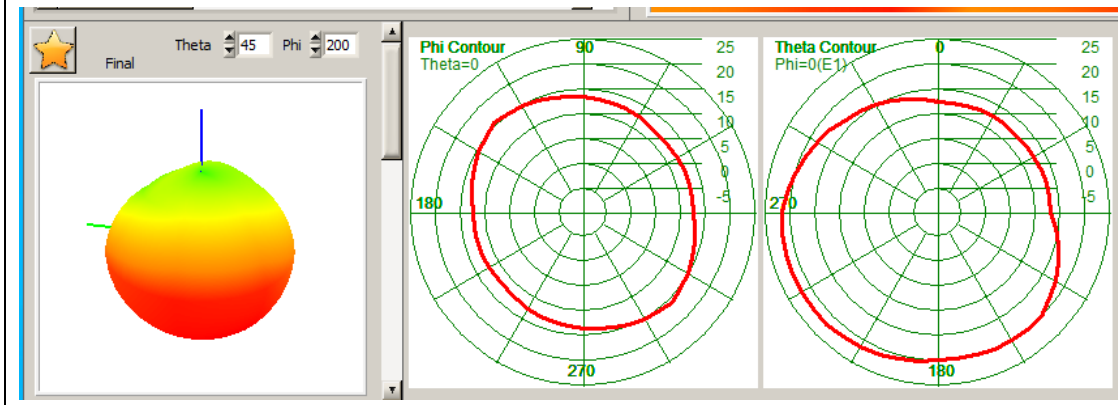

W8

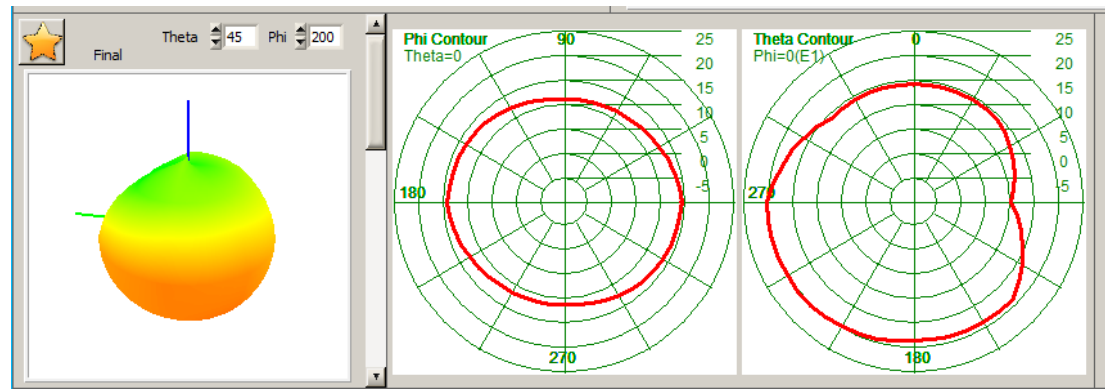

FDD-B2

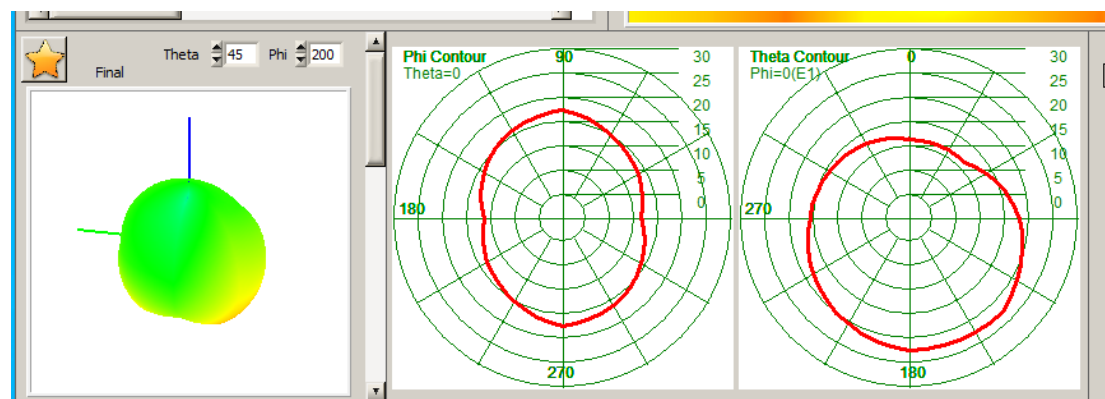

FDD-B3

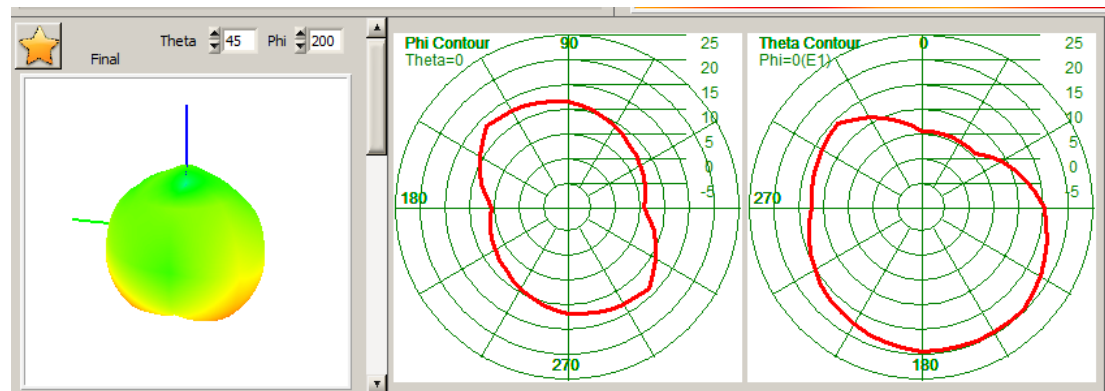

FDD-B4

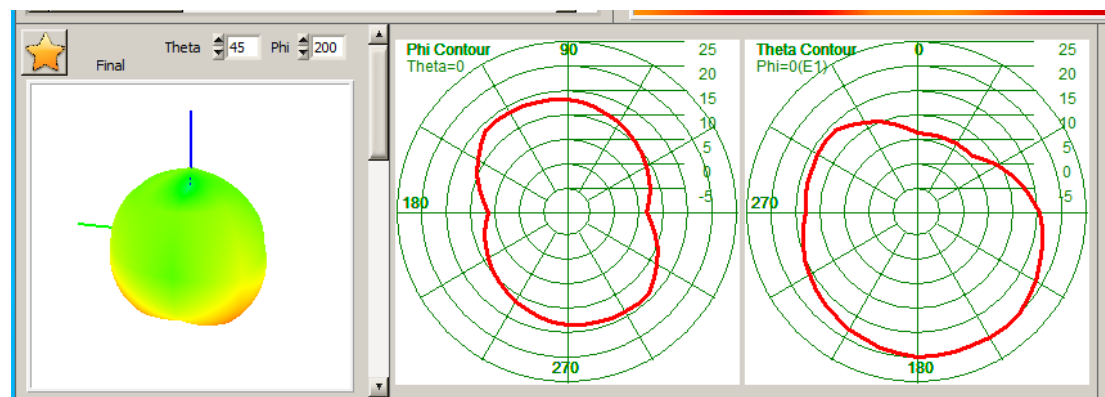

FDD-B5

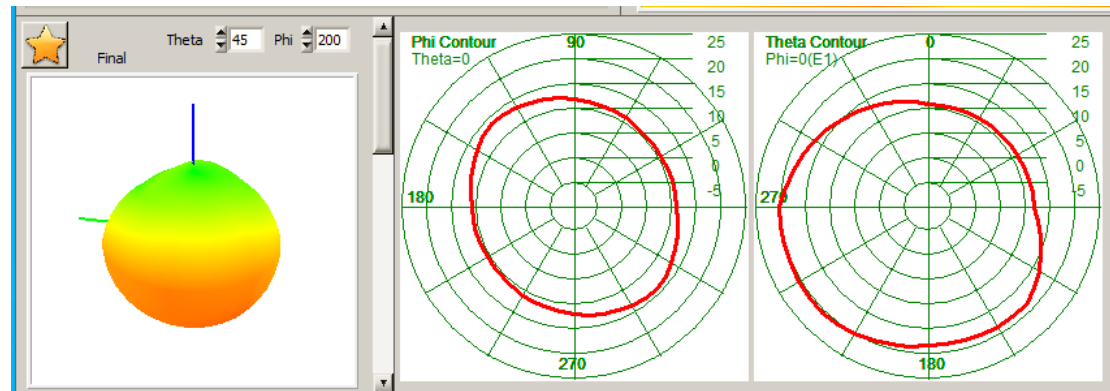

FDD-B8

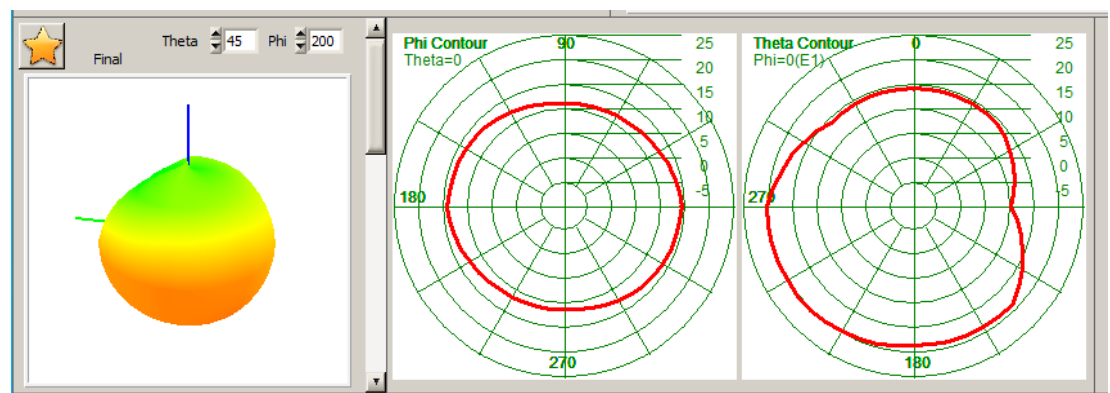

FDD-B12

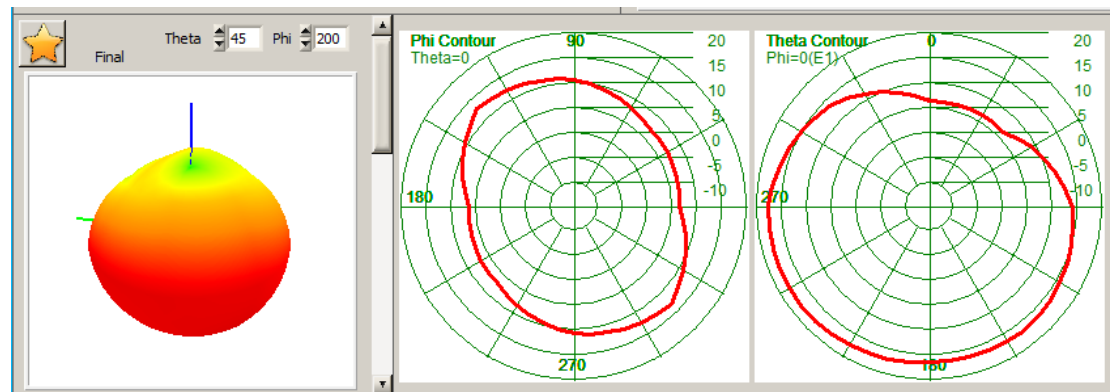

FDD-B17

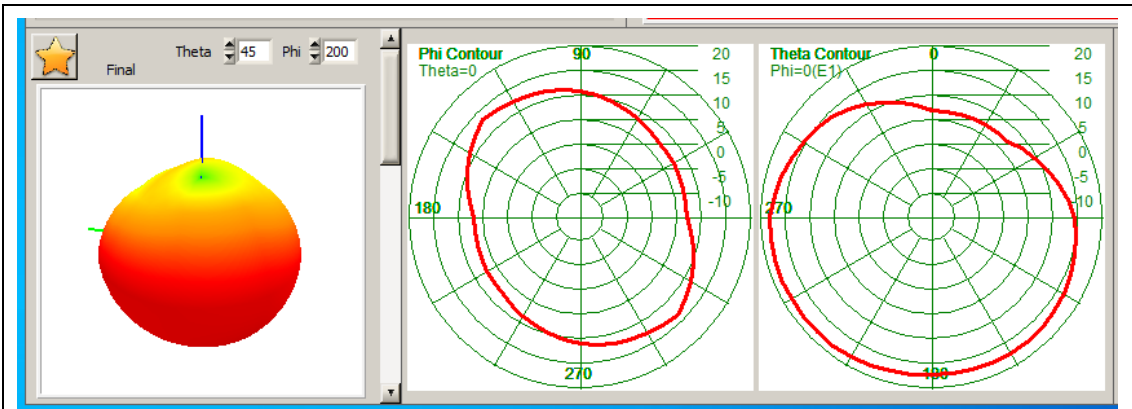

FDD-B28A

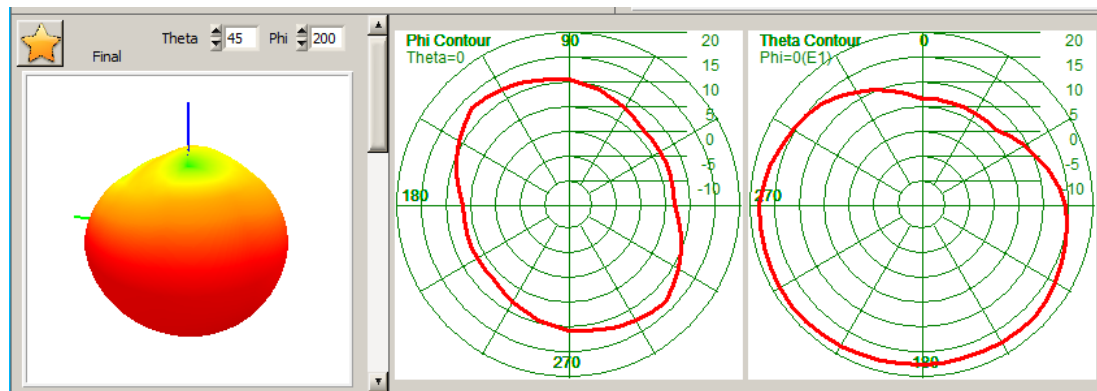

FDD-B28B

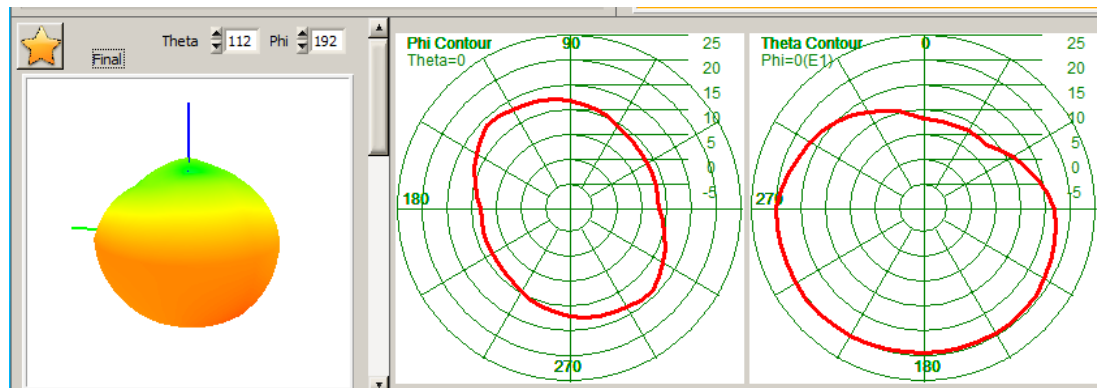

FDD-B66

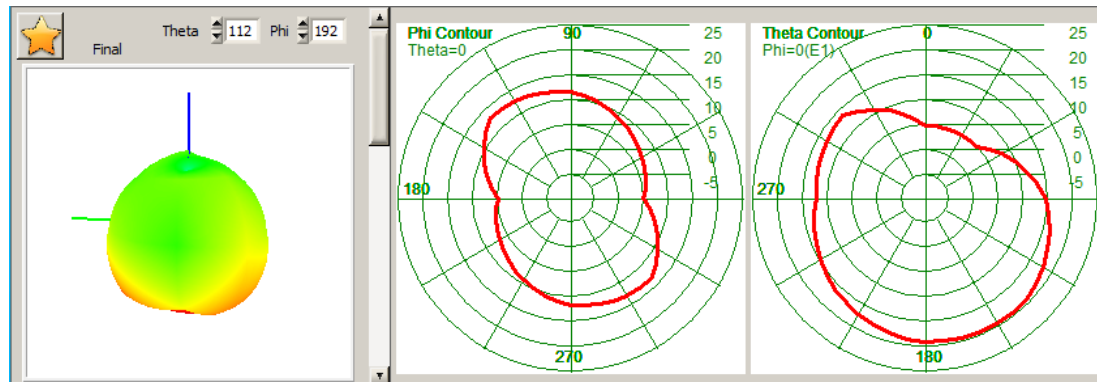

BT/2.4G-

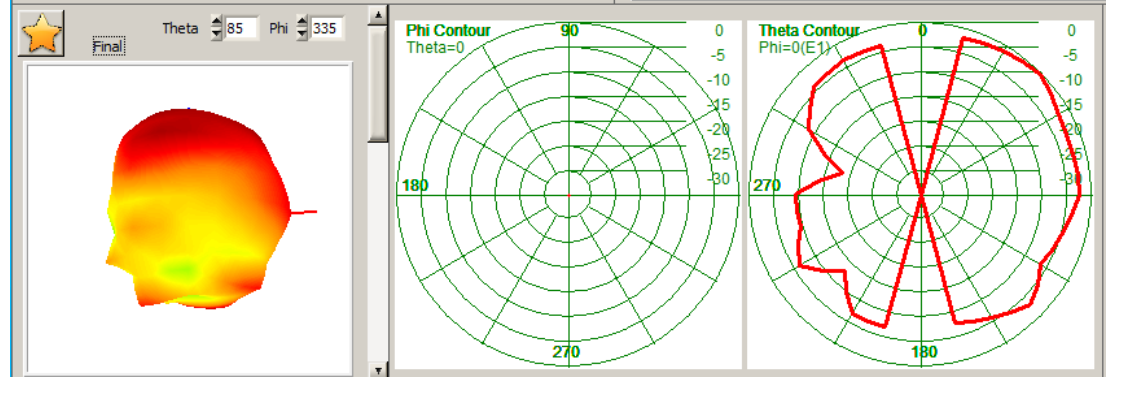

## 8.Introduction to Antenna Information

KC240	
Antenna type and frequency band	MAIN ANTENNA( <u>PIFA</u> ):2G/3G/4G DIV ANTENNA( <u>PIFA</u> ):2G/3G/4G BT ANTENNA( <u>IFA</u> ):2.4GBT
Antenna materia	FPC