

FRONT

FACTION GEL BATTLE SYSTEM

QUICK START GUIDE

SCAN FOR INSTRUCTIONS



This blaster has been disabled for safety and will not fire. It will flash yellow/red until unlocked.

FOLLOW STEPS 1 THRU 3 TO UNLOCK & RE-ENABLE YOUR BLASTER

IT'S A BLAST! - WITH OR WITHOUT THE APP

Once unlocked, the Faction Havoc works like any other gel bead blaster. It will not require any further connection to a phone or app to work. Just turn it on, load it up with gel bead ammo and blast away!

Connecting with the app is highly recommended however, as it will take your blasting game experience to a whole new level. When connected to the app, certain blaster functions (such as Firing Mode selection, LED lights, and the ability to fire) may be controlled by the app during gameplay. Full control may be restored at any time by closing the app and powering your blaster on and off.

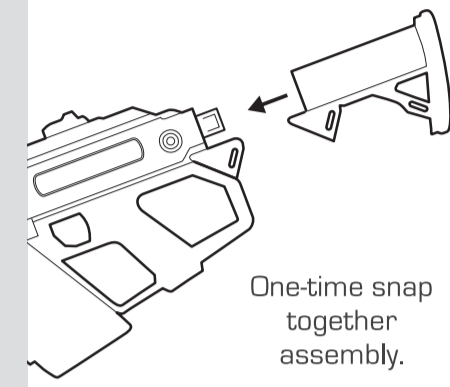

One-time snap together assembly.

INITIAL SET-UP

1 CHARGING YOUR BLASTER

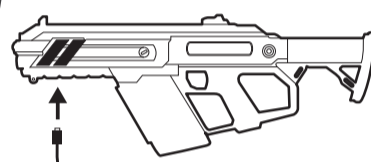

Plug charging cable into blaster and charging port. (Use included cable only)



5V 2A adapter Recommended (Sold Separately)



Flashing RED = charging



Solid GREEN = full charge

2 DOWNLOAD THE FREE FACTION BATTLE SYSTEM APP

Scan or visit FactionBattle.com to download and install the FREE Faction Battle System app. Update your phone to its most current operating system for best performance.



3 PAIR & UNLOCK YOUR BLASTER THROUGH THE APP

Ensure your phone's Bluetooth is on. Launch app, then turn blaster on to initiate pairing. (If blaster is already on, but not flashing blue, quickly turn off then on again to re-initiate pairing). Follow in-app instructions to select Faction Havoc. Blaster will pair, automatically unlock and be ready for use. Once paired, blaster will auto-pair to your phone whenever both the app is open and blaster is turned on. Should pairing fail, turn blaster off then on again and re-attempt connection.

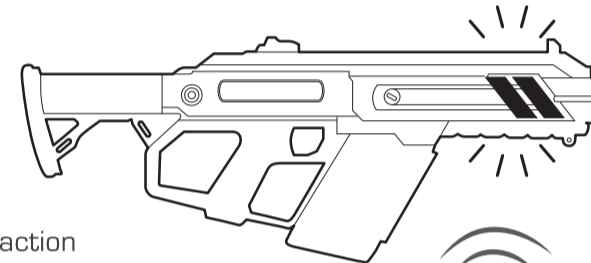

Flashing BLUE = pairing mode



NOTE: Faction blasters ONLY connect through the app. Blaster will not appear in your phone's Bluetooth settings. It can only connect when app is open and running and it will automatically disconnect when app is closed.

You can pair a blaster to a different phone by following the same steps. Just be sure to close app on original phone until blaster has successfully paired with new phone.

APP SUPPORTED FUNCTIONS REQUIRE PAIRING AND CELLULAR DATA.

THE HAVOC GEL BEAD BLASTER

LED LIGHT BARS

Light bars change color to display blaster status. Lights may be controlled by game when connected to the Faction app.

ACTION CAM MOUNT

Press and hold to talk with teammates. Release to stop talking.

CHAT BUTTON

Press and hold to talk with teammates. Release to stop talking.

FLUORESCENT OPTIC SIGHTS



AMMO CLIP RELEASE SWITCH

Slide forward to release and remove ammo clip

ON/OFF

CHAT and HIT buttons only function during gameplay when used with the Faction app.

HIT BUTTON

Press during gameplay to indicate you've been hit.

FIRING MODES

- **Single Fire:**
1 shot per trigger pull
- ≡ **Burst Fire:**
3 shots per trigger pull
- ≡≡ **Full Auto Fire:**
Shoot continuously until trigger is released

SAFETY:

Lock firing mechanism when not in use or charging.

PREPARING GEL BEADS



Pour dehydrated beads into water.

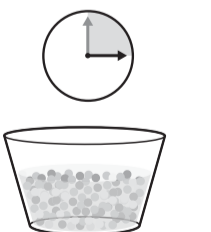

Soak 3 hours for full hydration.

Too little water may prevent beads from fully expanding and cause jams, misfires and poor performance. If in doubt, add more water.

LOADING THE AMMO CLIP

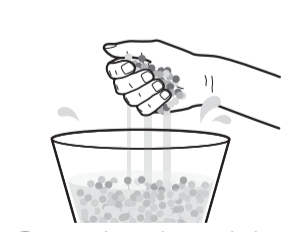

Scoop beads and drain water through fingers.



Open flap at top of clip and carefully fill with beads.

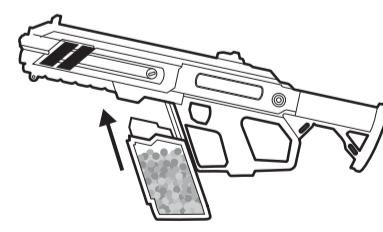

Slide ammo clip onto rail and push upward, until locked into position.

CLEAR BLASTER AND CLIP WHEN FINISHED: Uncleared beads will dry, stick, and cause jams next time you battle. After emptying ammo clip, reattach to blaster, turn blaster upside down, and fire blaster until the feed tube in the ammo clip is clear of all beads.

BACK

SMART BEACON ASSEMBLY

Press and momentarily hold to turn ON. Press and hold again to turn OFF. Refer to app set-up instructions for use with app.

Install 3X AAA (LR 03) (Not Included)

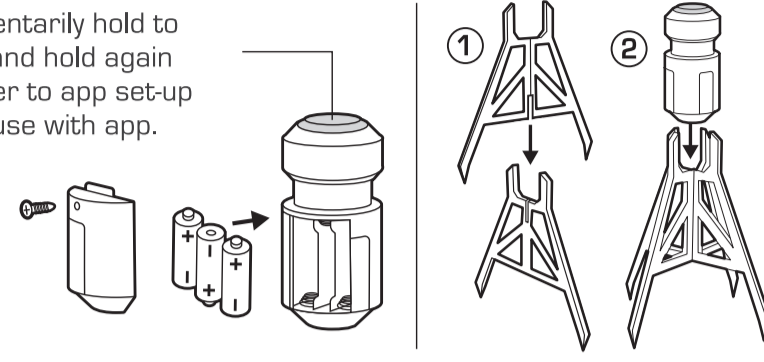

PLAYING TARGET PRACTICE (WITHOUT APP)

Turn beacon on. Blast the beacon when it turns BLUE, but don't blast it when the light turns off.

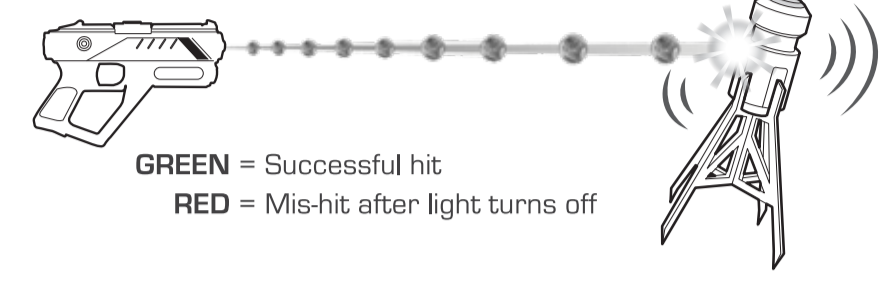

GREEN = Successful hit
RED = Mis-hit after light turns off

TROUBLESHOOTING

Blaster is flashing yellow and red.	Blaster is still locked. Download Faction app and follow instructions for one-time pairing and unlocking.
Blaster is solid blue, but blaster does not fire.	- Check firing mode switch to ensure the safety lock is not selected. - Firing ability may be suspended by app control. Close app and turn blaster off and on to regain full control. - Blaster may be jammed. Follow instructions for clearing a jam. - If still unresponsive, turn blaster off then on again.
Blaster works fine, but app is not connecting or cannot see it.	Ensure your phone's Bluetooth is turned on and the app has permission to use it. With the app open and running, turn blaster off the on again to restart the pairing process. If previously paired, blaster should auto-pair.
Blaster is firing slowly.	Blaster power is running low. Follow instructions for charging.
Gel beads aren't firing correctly or are rolling out of the blaster barrel.	Gel beads may not be fully hydrated. Allow more hydration time and add water if partially hydrated beads are floating above the water level.

CLEARING A JAM:

Turn power off and remove ammo clip. Shake blaster sharply 3 or 4 times to clear chamber, then fire the blaster to ensure the jam is resolved. Smack ammo clip against your hand to free any clip jam. If still jammed, spray canned air into upper chamber to loosen until jam drains down barrel. Never stick any object into barrel, upper chamber or ammo clip as it may worsen jam or cause damage.

STORING HYDRATED BEADS:

Keep ammo hydrated and ready for action for up to 1 week. Submerge in water and seal in a container with lid out of direct sunlight.

ADULT SUPERVISION REQUIRED:

- **EYEWEAR REQUIRED:** DO NOT AIM AT EYES OR FACE. Misuse or careless use may cause serious injury, especially to the eye. Impact from gel beads may cause temporary marks on skin. Gel beads may stain. Eye protection must be worn by user and any person within range. Use only Faction brand gel bead ammo. Use only clean tap water to hydrate gel beads. Do not freeze or modify gel beads. Included eyewear intended only for use with Faction gel blasters.
- The eyewear is intended to be used only with Faction gel bead blaster. Failure to follow all these instructions or adhere to both, or all these warnings may result in serious or permanent injury. Never remove the goggles while using gel bead blasters. Wear the goggles whenever using a gel bead blaster and whenever in or near an area where gel bead blasters are being used. Check the lens before and after use and replace the goggles immediately if any cracks are observed anywhere in the lens. Do not play with gel bead blasters if the lens is subject to a direct impact and develops a crack or fracture or damage of any kind and replace the goggles immediately. Clean the goggles with tap water. The goggles are suitable for age 14+. Not for use in low light conditions.
- **DO NOT BRANDISH IN PUBLIC:** DO NOT BRANDISH THIS PRODUCT IN PUBLIC as it may cause confusion and may be a crime. This product may be mistaken for an actual firearm by authorities and/or other law enforcement agencies. Any alteration of state or federal recommended markings, coloration, or alterations in order to make the product appear more realistic is dangerous and may be a crime.
- **CHECK LOCAL LAWS:** Criminal penalties may be possible under state & federal law from use of a replica firearm in a prohibited or threatening manner. Consumers should confirm the lawful use of this product with local authorities before using in public spaces as laws may vary.

UPGRADE YOUR ARSENAL

LEARN MORE ABOUT FACTION
FACTIONBATTLE.COM

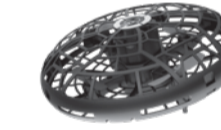

SKYFIRE TARGET DRONE



SPECTRE GEL BEAD BLASTER



20,000 GEL BEAD AMMO



10,000 GLOW IN THE DARK GEL BEAD AMMO



SENTINEL R/C TURRET GEL BEAD BLASTER

BLASTER

THIS PRODUCT CONTAINS A LITHIUM-ION BATTERY:

Lithium batteries have a severe risk of fire and injury if they are improperly handled or misused. They may explode, overheat or ignite. Do not open, crush or modify this product. Do not incinerate or heat above 113°F / 45°C. Read all directions regarding use, care and disposal. Read all following precautions and instructions regarding the care and use of Lithium batteries.

- Keep away from flammable materials.
- Do not expose to direct sunlight.
- Do not place in a fire or leave in hot places.
- Do not drop or make subject to strong impact.
- Keep dry and away from water.
- The supply terminals are not to be short circuited.
- Never throw into a fire or attempt to open outer case.
- Do not stress, press or drop.
- Never charge unattended. When charging you should always remain in constant observation to monitor the charging process and react to potential problems that may occur.
- Disconnect charging cable if fully charged.
- Never store or charge inside a car in extreme temperatures, since extreme temperature could ignite fire.
- Use caution to avoid puncture. Puncture of battery may cause a fire.
- **Lithium Battery Disposal:** Lithium batteries must be recycled or disposed of properly. They should not be disposed of with other household waste. Check your local laws and regulations for correct recycling and/or battery disposal.

BEACON

AAA BATTERY WARNINGS & SPECIFICATIONS:

- Do not use rechargeable batteries.
- Non-rechargeable batteries are not to be recharged.
- Do not mix old and new batteries and Do not mix alkaline, standard (carbon-zinc) or rechargeable (nicad, nimh, etc.) batteries.
- Batteries are to be inserted using correct polarity.
- Remove exhausted batteries as soon as possible and discard properly.
- Remove all batteries from compartment if beacon is not used for a long period of time.
- The supply terminals are not to be short circuited.
- Batteries should be replaced by an adult.
- Never throw batteries in a fire or attempt to open the outer casing.

WARNING: Batteries are harmful if swallowed. Please keep away from children.

Battery Disposal: Dispose of batteries according to the local laws and regulations of your region. Some batteries may be recycled, and may be accepted for disposal at your local recycling center. If you are not able to identify the application rules in your area, please check the instructions of the battery manufacturer.

This device complies with PART 15 of the FCC Rules. Operation is subject to the following two conditions: (1) This device may not cause harmful interference, and (2) This device must accept any interference received, including interference that may cause undesired operation. **CAUTION:** Changes or modifications to this unit not expressly approved by the party responsible for compliance could void the user's authority to operate the equipment. **NOTE:** This equipment has been tested and found to comply with the limits for a Class B digital device, pursuant to Part 15 of the FCC rules. These limits are designed to provide reasonable protection against harmful interference in a residential installation. This equipment generates, uses and can radiate radio frequency energy and, if not installed and used in accordance with the instructions, may cause harmful interference to radio communications. However, there is no guarantee that interference will not occur in a particular installation. If this equipment does cause harmful interference to radio or television reception, which can be determined by turning the equipment off and on, the user is encouraged to try to correct the interference by one or more of the following measures: Reorient or relocate the receiving antenna - Increase the separation between the equipment and receiver - Connect the equipment into an outlet on a circuit different from that to which the receiver is connected - Consult the dealer or an experienced radio/TV technician for help.

WARNING: This produces flashes that may trigger epilepsy in sensitized individuals.

Google Play is a trademark of Google Inc. - Apple, the Apple logo, the iPhone and the App Store are trademarks of Apple Inc., registered in the U.S. and other countries. The App Store is a service mark of Apple Inc.

©2023 Skyrocket LLC, Los Angeles, CA 90292 USA. All Rights Reserved. Faction and the Skyrocket logo are trademarks of Skyrocket LLC. Other trademarks and trade names are those of their respective owners, and there is no relationship express or implied with Skyrocket LLC. MADE IN CHINA

Item # 18587
Item # 18586B
HAVOC FCC ID: O531858724G
BEACON FCC ID: O5318586B24G
SKYROCKET®

Questions or comments?
Please email support
@skyrockettoys.com