



Hermon Laboratories Ltd.
Harakevet Industrial Zone, Binyamina 30500,
Israel
Tel. +972-4-6288001
Fax. +972-4-6288277
E-mail: mail@hermonlabs.com

TEST REPORT

ACCORDING TO: FCC 47CFR part 15 subpart C § 15.209

FOR:

Elpas Solutions Ltd.
Wiegand 26 Bit Proximity reader
Models: RDR-2, RDR-1B, RDR-4
FCC ID:O4X3-63040

This report is in conformity with ISO/IEC 17025. The "A2LA Accredited" symbol endorsement applies only to the tests and calibrations that are listed in the scope of Hermon Laboratories accreditation. The test results relate only to the items tested. This test report shall not be reproduced in any form except in full with the written approval of Hermon Laboratories Ltd.



Table of contents

1	Applicant information.....	3
2	Equipment under test attributes	3
3	Manufacturer information	3
4	Test details.....	3
5	Tests summary.....	4
6	EUT description.....	5
6.1	General information.....	5
6.2	Test configuration.....	5
6.3	EUT modules and sub-assemblies.....	6
6.4	Ports and lines	6
6.5	Changes made in EUT	6
7	Transmitter tests according to 47CFR part 15 subpart C requirements	7
7.1	Field strength of emissions.....	7
7.2	Conducted emissions	15
7.3	Antenna requirements.....	18
8	APPENDIX A Test equipment and ancillaries used for tests.....	19
9	APPENDIX B Measurement uncertainties.....	20
10	APPENDIX C Test laboratory description	21
11	APPENDIX D Specification references	21
12	APPENDIX E Test equipment correction factors.....	22
13	APPENDIX F Abbreviations and acronyms.....	28
14	APPENDIX G Manufacturer's declaration	29



HERMON LABORATORIES

1 Applicant information

Client name: Elpas Solutions Ltd.
Address: 23 Habarzel street, Tel Aviv 69710, Israel
Telephone: +972 3768 1421
Fax: +972 3768 1415
E-mail: MErenkrantz@tycoint.com
Contact name: Mr. Meir Erenkrantz

2 Equipment under test attributes

Product name: Wiegand 26 Bit Proximity reader
Product type: Transmitter
Model(s): RDR-2
Serial number: 3-6302-0
Hardware version: C31
Software release: 2
Receipt date: 8/05/2013

3 Manufacturer information

Manufacturer name: Visonic Ltd.
Address: 24 Habarzel street, Tel Aviv 69710, Israel
Telephone: +972 3768 1421
Fax: +972 3768 1415
E-Mail: MErenkrantz@tycoint.com
Contact name: Mr. Meir Erenkrantz

4 Test details

Project ID: 24722
Location: Hermon Laboratories Ltd. Harakevet Industrial Zone, Binyamina 30500, Israel
Test started: 8/05/2013
Test completed: 8/14/2013
Test specification(s): FCC 47CFR part 15, subpart C, §15.209



5 Tests summary

Test	Status
Transmitter characteristics	
FCC Section 15.209, Field strength of emissions	Pass
FCC Section 15.207(a), Conducted emission	Pass
FCC Section 15.203, Antenna requirements	Pass

Testing was completed against all relevant requirements of the test standard. The results obtained indicate that the product under test complies in full with the requirements tested.

The test results relate only to the items tested. Pass/ fail decision was based on nominal values.

	Name and Title	Date	Signature
Tested by:	Mrs. E. Pitt, test engineer	August 14, 2013	
Reviewed by:	Mrs. M. Cherniavsky, certification engineer	August 28, 2013	
Approved by:	Mr. M. Nikishin, EMC and Radio group manager	October 2, 2013	



6 EUT description

6.1 General information

The EUT is a proximity reader connected to AXS-100 access control system via a six-wire cable. The reader comprises a LF transmitter operating at 125 kHz with ASK type of modulation. The EUT has 3 models which are electrically and electronically identical according to a manufacturer declaration represented in Appenfix G of this test report. The RDR-2 and RDR-1B models are the external proximity readers. The RDR-4 model is indoor proximity reader. The RDR-2 model was tested.

6.2 Test configuration

6.2.1 Field strength measurements

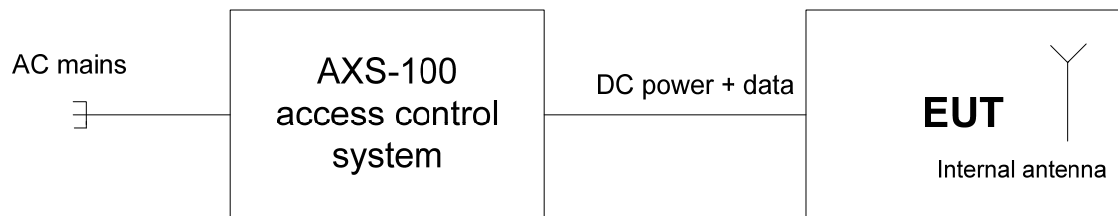

6.2.2 Conducted emission measurements

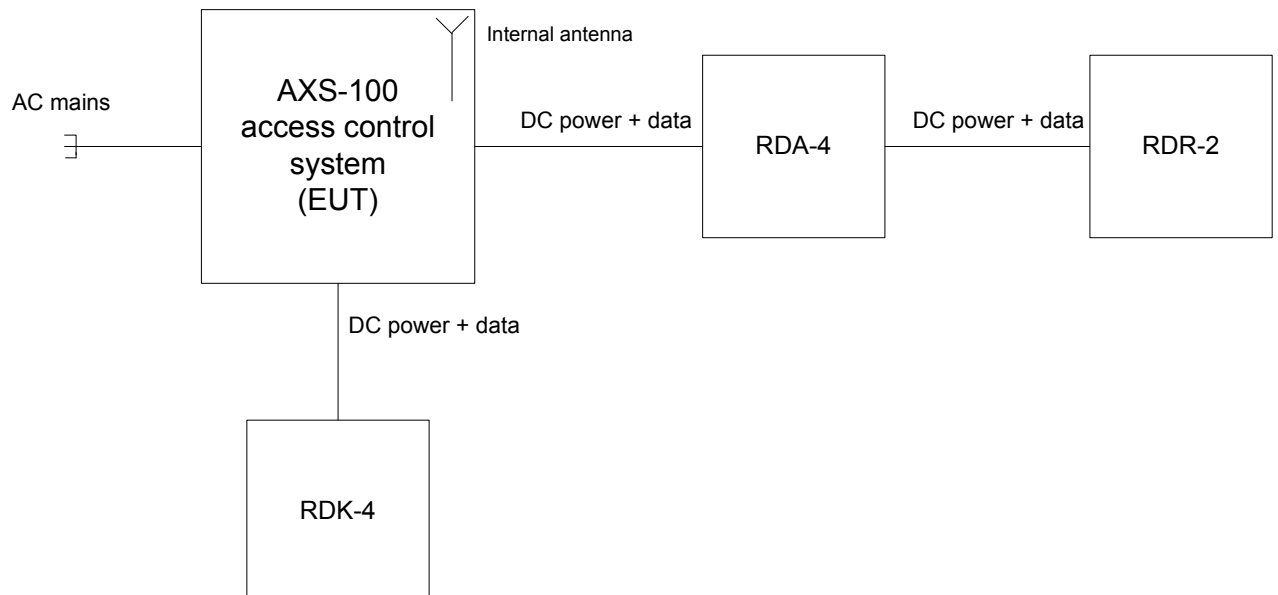



6.3 EUT modules and sub-assemblies

Description	Manufacturer	Model or P/N	Hardware rev.	Serial number
Reader	Visonic	RDR-2	C31	3-6302-0
Access control system	Visonic	AXS-100	Rev F	3-6281-7
Reader	Visonic	RDK-4	Rev.F	3-6321-0
Adaptor	Visonic	RDA-4	Rev d4	3-6319-0

6.4 Ports and lines

Port type	Port description	Connected from	Connected to	Qty.	Cable type	Cable length, m
Power	AC	AXS-100	AC mains	1	Unshielded	2
Signal	Data	RDK-4	AXS-100	4	Unshielded	10
Signal	Data	RDR-2	RDA-4	4	Unshielded	10
Signal	Data	RDA-4	AXS-100	4	Unshielded	10

6.5 Changes made in EUT

No changes were performed in the EUT during testing.



Test specification:	Section 15.209, Field strength of emissions		
Test procedure:	ANSI C63.4, Section 13.1.4		
Test mode:	Compliance	Verdict:	PASS
Date(s):	8/5/2013		
Temperature: 25 °C	Air Pressure: 1006 hPa	Relative Humidity: 46 %	Power Supply: 120 VAC
Remarks:			

7 Transmitter tests according to 47CFR part 15 subpart C requirements

7.1 Field strength of emissions

7.1.1 General

This test was performed to measure field strength of fundamental and spurious emissions from the EUT. Specification test limits are given Table 7.1.1 and Table 7.1.2.

Table 7.1.1 Radiated fundamental emission limits

Fundamental frequency, kHz	Field strength at 3 m, dB(μV/m)
	Average
121	106

Table 7.1.2 Radiated spurious emissions limits

Frequency, MHz	Field strength at 3 m, dB(μV/m)		
	Within restricted bands		
	Peak	Quasi Peak	Average
0.009 – 0.090	148.5 – 128.5	NA	128.5 – 108.5**
0.090 – 0.110	NA	108.5 – 106.8**	NA
0.110 – 0.490	126.8 – 113.8	NA	106.8 – 93.8**
0.490 – 1.705	NA	73.8 – 63.0**	NA
1.705 – 30.0*		69.5	
30 – 88		40.0	
88 – 216		43.5	
216 – 960		46.0	
960 - 1000		54.0	
1000 – 10 th harmonic	74.0	NA	54.0

*- The limit for 3 m test distance was calculated using the inverse square distance extrapolation factor as follows:

$$\text{Lim}_{S_2} = \text{Lim}_{S_1} + 40 \log (S_1/S_2),$$

where S₁ and S₂ – standard defined and test distance respectively in meters.

** - The limit decreases linearly with the logarithm of frequency.

7.1.2 Test procedure for fundamental and spurious emission field strength measurements in 9 kHz to 30 MHz

7.1.2.1 The EUT was set up as shown in Figure 7.1.1, energized and the performance check was conducted.

7.1.2.2 The specified frequency range was investigated with a loop antenna connected to spectrum analyzer/ EMI receiver. To find maximum radiation the turntable was rotated 360°, the measuring antenna was rotated around its vertical axis. The measuring antenna polarization was switched from vertical to horizontal.

7.1.2.3 The worst test results (the lowest margins) were recorded in Table 7.1.3 and shown in the associated plots.

7.1.3 Test procedure for spurious emission field strength measurements above 30 MHz

7.1.3.1 The EUT was set up as shown in Figure 7.1.2, energized and the performance check was conducted.

7.1.3.2 The specified frequency range was investigated with antenna connected to spectrum analyzer/ EMI receiver. To find maximum radiation the turntable was rotated 360°, the measuring antenna height was changed from 1 to 4 m, its polarization was switched from vertical to horizontal.

7.1.3.3 The worst test results (the lowest margins) were recorded in Table 7.1.4 and shown in the associated plots.



Test specification:	Section 15.209, Field strength of emissions		
Test procedure:	ANSI C63.4, Section 13.1.4		
Test mode:	Compliance	Verdict:	PASS
Date(s):	8/5/2013		
Temperature: 25 °C	Air Pressure: 1006 hPa	Relative Humidity: 46 %	Power Supply: 120 VAC
Remarks:			

Figure 7.1.1 Setup for spurious emission field strength measurements below 30 MHz

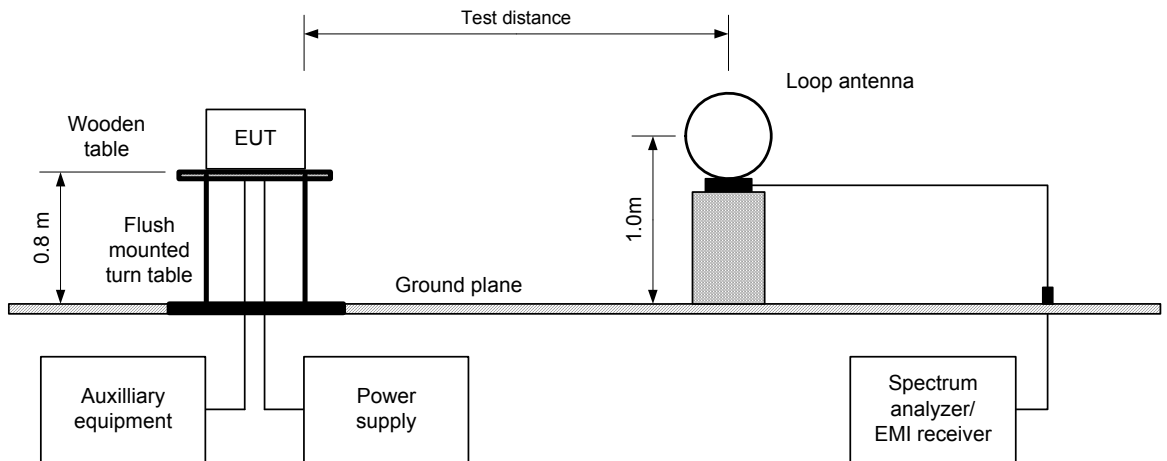
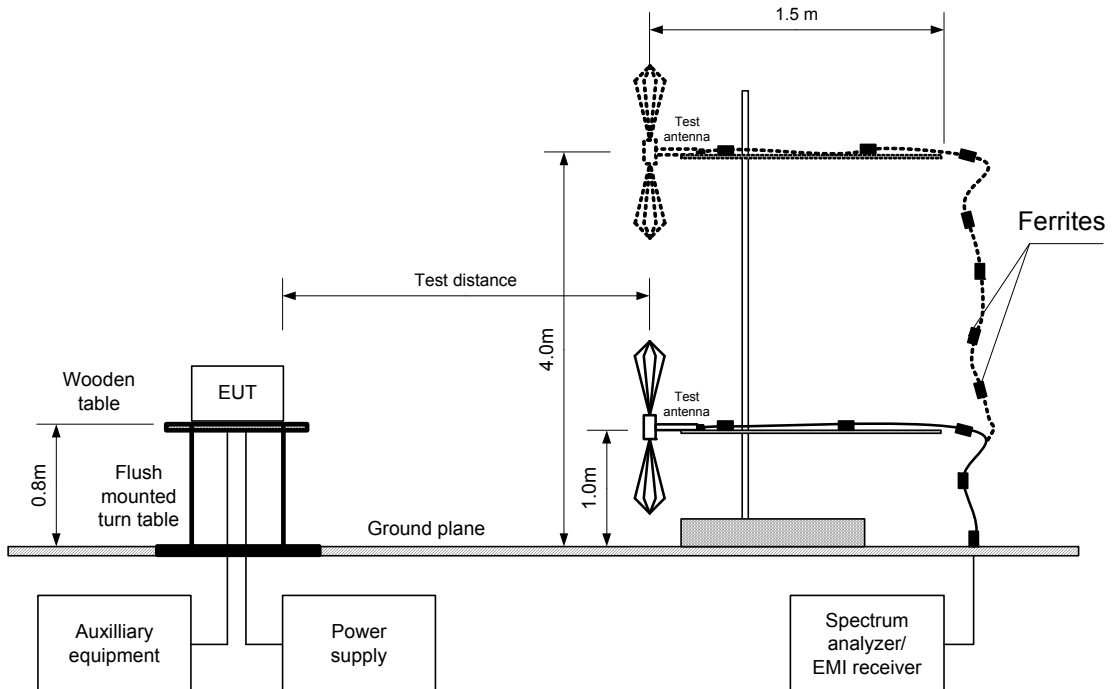

Figure 7.1.2 Setup for spurious emission field strength measurements above 30 MHz





Test specification:		Section 15.209, Field strength of emissions	
Test procedure:		ANSI C63.4, Section 13.1.4	
Test mode:		Compliance	
Date(s):		8/5/2013	
Temperature: 25 °C		Air Pressure: 1006 hPa	
		Relative Humidity: 46 %	
		Power Supply: 120 VAC	
Remarks:			

Table 7.1.3 Field strength of fundamental emission

TEST DISTANCE:	3 m
TEST SITE:	Semi Anechoic chamber
EUT POSITION:	Typical (Vertical)
MODULATION:	ASK
TRANSMITTER OUTPUT POWER SETTINGS:	Maximum
INVESTIGATED FREQUENCY RANGE:	0.009 – 1000 MHz
DETECTOR USED:	Peak
RESOLUTION BANDWIDTH:	1 kHz (9 kHz – 150 kHz) 9.0 kHz (150 kHz – 30 MHz) 120 kHz (30 MHz – 1000 MHz)
VIDEO BANDWIDTH:	≥ Resolution bandwidth
TEST ANTENNA TYPE:	Active loop (9 kHz – 30 MHz)

F, kHz	Antenna		Azimuth, degrees*	Peak field strength			Average field strength			Verdict
	Pol.	Height, m		Measured, dB(μV/m)	Limit, dB(μV/m)	Margin, dB**	Measured, dB(μV/m)	Limit, dB(μV/m)	Margin, dB**	
120.826	V	1.0	0	89.92	126.0	-36.08	89.92	106.0	-16.08	Pass

*- EUT front panel refers to 0 degrees position of turntable.

**- Margin (dB) = measured result - specification limit.

Reference numbers of test equipment used

HL 0446	HL 2871	HL 3818	HL 4353				
---------	---------	---------	---------	--	--	--	--

Full description is given in Appendix A.



Test specification:		Section 15.209, Field strength of emissions	
Test procedure:		ANSI C63.4, Section 13.1.4	
Test mode:		Compliance	
Date(s):		8/5/2013	
Temperature: 25 °C		Air Pressure: 1006 hPa	
		Relative Humidity: 46 %	
		Power Supply: 120 VAC	
Remarks:			

Table 7.1.4 Field strength of spurious emissions

TEST DISTANCE: 3 m
 TEST SITE: Semi Anechoic chamber
 EUT POSITION: Typical (Vertical)
 MODULATION: ASK
 TRANSMITTER OUTPUT POWER SETTINGS: Maximum
 INVESTIGATED FREQUENCY RANGE: 0.009 – 1000 MHz
 DETECTOR USED: Peak
 RESOLUTION BANDWIDTH: 1 kHz (9 kHz – 150 kHz)
 9.0 kHz (150 kHz – 30 MHz)
 120 kHz (30 MHz – 1000 MHz)
 VIDEO BANDWIDTH: ≥ Resolution bandwidth
 TEST ANTENNA TYPE: Active loop (9 kHz – 30 MHz)
 Biconilog (30 MHz – 1000 MHz)

Frequency, MHz	Peak emission, dB(μV/m)	Quasi-peak			Antenna polarization	Antenna height, m	Turn-table position**, degrees	Verdict
		Measured emission, dB(μV/m)	Limit, dB(μV/m)	Margin, dB*				
All signals were found at least 20 dB below the limit								Pass

*- Margin = Measured emission - specification limit.
 **- EUT front panel refer to 0 degrees position of turntable.

Table 7.1.5 Restricted bands

MHz	MHz	MHz	MHz	MHz	GHz
0.09 - 0.11	8.37625 - 8.38675	73 - 74.6	399.9 - 410	2690 - 2900	10.6 - 12.7
0.495 - 0.505	8.41425 - 8.41475	74.8 - 75.2	608 - 614	3260 - 3267	13.25 - 13.4
2.1735 - 2.1905	12.29 - 12.293	108 - 121.94	960 - 1240	3332 - 3339	14.47 - 14.5
4.125 - 4.128	12.51975 - 12.52025	123 - 138	1300 - 1427	3345.8 - 3358	15.35 - 16.2
4.17725 - 4.17775	12.57675 - 12.57725	149.9 - 150.05	1435 - 1626.5	3600 - 4400	17.7 - 21.4
4.20725 - 4.20775	13.36 - 13.41	156.52475 - 156.52525	1645.5 - 1646.5	4500 - 5150	22.01 - 23.12
6.215 - 6.218	16.42 - 16.423	156.7 - 156.9	1660 - 1710	5350 - 5460	23.6 - 24
6.26775 - 6.26825	16.69475 - 16.69525	162.0125 - 167.17	1718.8 - 1722.2	7250 - 7750	31.2 - 31.8
6.31175 - 6.31225	16.80425 - 16.80475	167.72 - 173.2	2200 - 2300	8025 - 8500	36.43 - 36.5
8.291 - 8.294	25.5 - 25.67	240 - 285	2310 - 2390	9000 - 9200	Above 38.6
8.362 - 8.366	37.5 - 38.25	322 - 335.4	2483.5 - 2500	9300 - 9500	

Reference numbers of test equipment used

HL 0446	HL 0604	HL 2871	HL 3818	HL 4353		
---------	---------	---------	---------	---------	--	--

Full description is given in Appendix A.



HERMON LABORATORIES

Test specification:		Section 15.209, Field strength of emissions	
Test procedure:		ANSI C63.4, Section 13.1.4	
Test mode:		Compliance	
Date(s):		8/5/2013	
Temperature: 25 °C		Air Pressure: 1006 hPa	
Relative Humidity: 46 %		Power Supply: 120 VAC	
Remarks:			

Plot 7.1.1 Radiated emission measurements at the fundamental frequency

TEST SITE: Semi anechoic chamber
 TEST DISTANCE: 3 m
 EUT POSITION: Typical (Vertical)

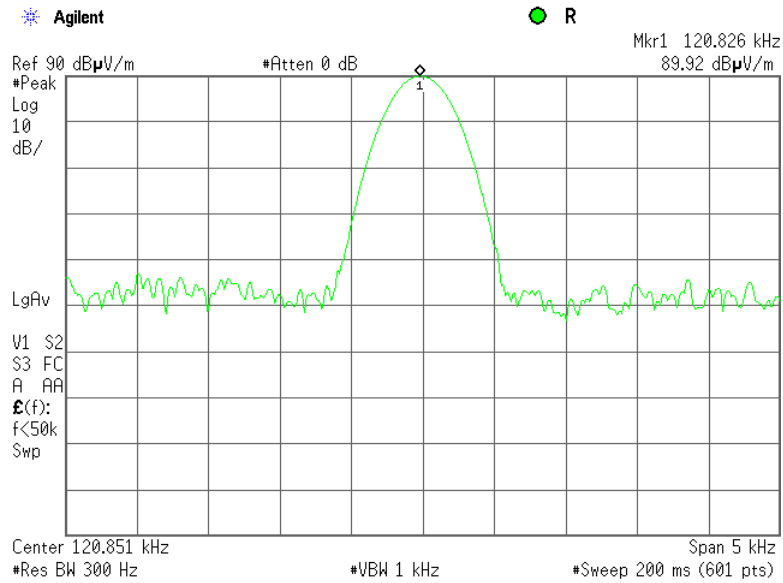



HERMON LABORATORIES

Test specification:		Section 15.209, Field strength of emissions	
Test procedure:		ANSI C63.4, Section 13.1.4	
Test mode:		Compliance	
Date(s):		8/5/2013	
Temperature: 25 °C		Air Pressure: 1006 hPa	
Relative Humidity: 46 %		Power Supply: 120 VAC	
Remarks:			
		Verdict: PASS	

Plot 7.1.2 Radiated emission measurements from 9 to 150 kHz

TEST SITE: Semi Anechoic chamber
TEST DISTANCE: 3 m
EUT POSITION: Typical (Vertical)

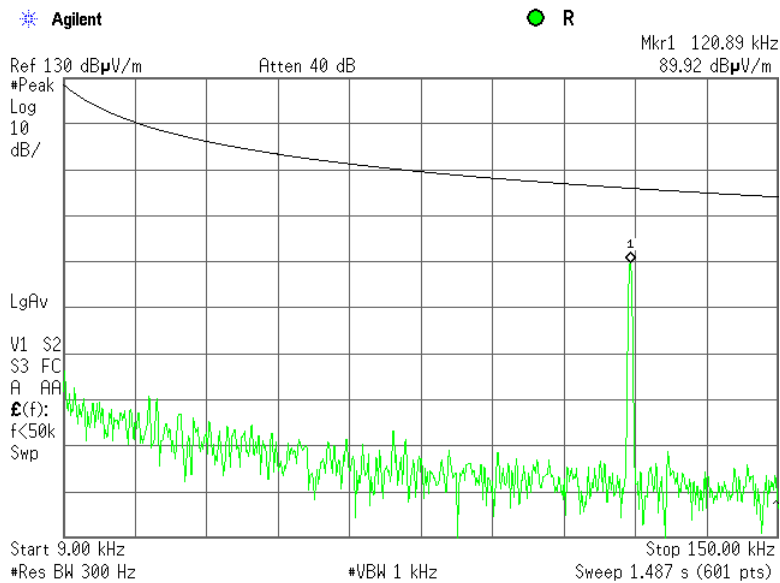

Plot 7.1.3 Radiated emission measurements from 0.15 to 30 MHz

TEST SITE: Semi Anechoic chamber
TEST DISTANCE: 3 m
EUT POSITION: Typical (Vertical)

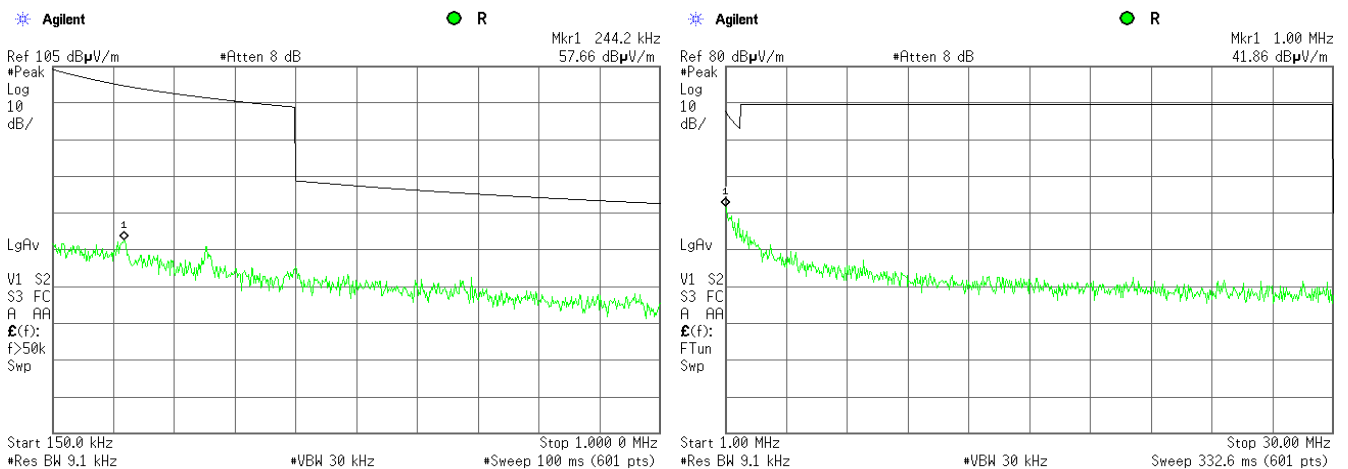



HERMON LABORATORIES

Test specification:		Section 15.209, Field strength of emissions	
Test procedure:		ANSI C63.4, Section 13.1.4	
Test mode:		Compliance	
Date(s):		8/5/2013	
Temperature: 25 °C		Air Pressure: 1006 hPa	
		Relative Humidity: 46 %	
		Power Supply: 120 VAC	
Remarks:			
		Verdict: PASS	

Plot 7.1.4 Radiated emission measurements from 30 to 1000 MHz

TEST SITE: Semi anechoic chamber
TEST DISTANCE: 3 m
ANTENNA POLARIZATION: Vertical
EUT POSITION: Typical (Vertical)

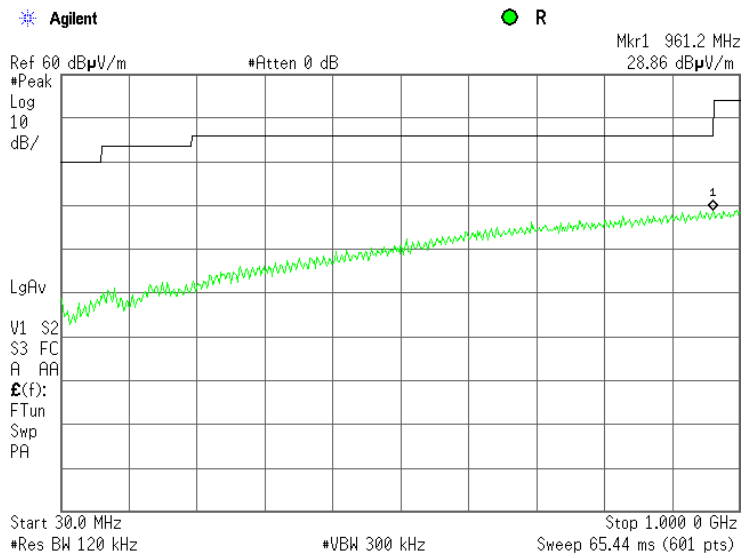

Plot 7.1.5 Radiated emission measurements from 30 to 1000 MHz

TEST SITE: Semi anechoic chamber
TEST DISTANCE: 3 m
ANTENNA POLARIZATION: Horizontal
EUT POSITION: Typical (Vertical)

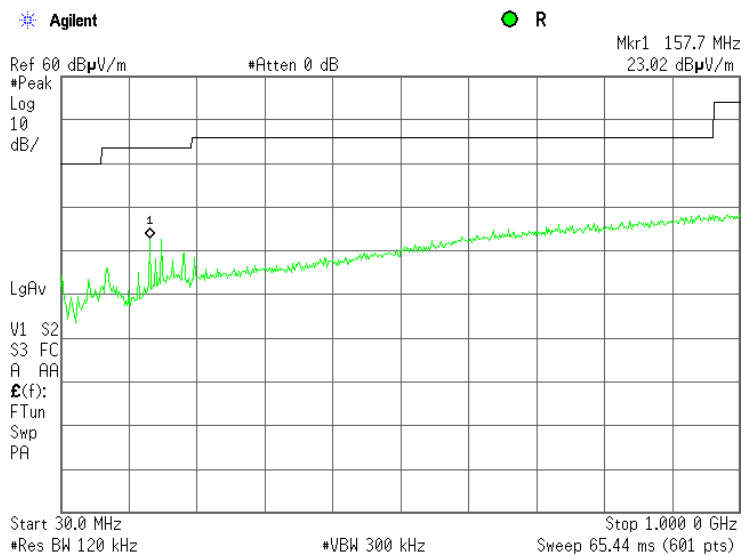



Test specification:	Section 15.209, Field strength of emissions		
Test procedure:	ANSI C63.4, Section 13.1.4		
Test mode:	Compliance	Verdict:	PASS
Date(s):	8/5/2013		
Temperature: 25 °C	Air Pressure: 1006 hPa	Relative Humidity: 46 %	Power Supply: 120 VAC
Remarks:			

Plot 7.1.6 Radiated emission measurements at the second harmonic frequency

TEST SITE: Semi anechoic chamber
 TEST DISTANCE: 3 m
 EUT POSITION: Typical (Vertical)

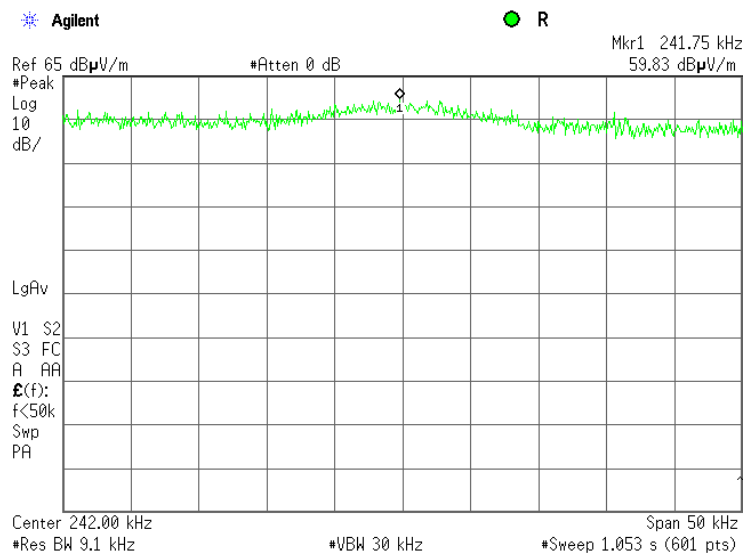

Plot 7.1.7 Radiated emission measurements at the third harmonic frequency

TEST SITE: Semi anechoic chamber
 TEST DISTANCE: 3 m
 EUT POSITION: Typical (Vertical)

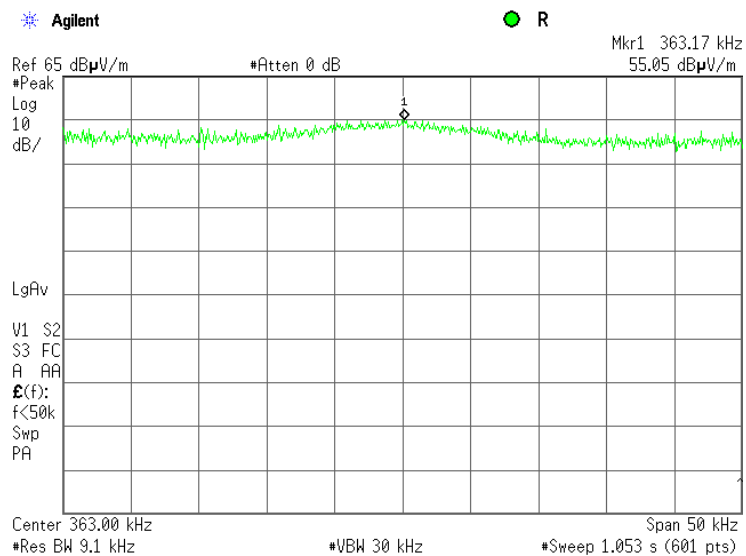



Test specification:	Section 15.207(a), Conducted emission		
Test procedure:	ANSI C63.4, Section 13.1.3		
Test mode:	Compliance	Verdict:	PASS
Date(s):	7/31/2013		
Temperature: 24 °C	Air Pressure: 1007 hPa	Relative Humidity: 50 %	Power Supply: 120 VAC
Remarks:			

7.2 Conducted emissions

7.2.1 General

This test was performed to measure the common mode conducted emissions at the EUT power port. The specification test limits are given in Table 7.2.1.

Table 7.2.1 Limits for conducted emissions

Frequency, MHz	Class B limit, dB(μV)		Class A limit, dB(μV)	
	QP	AVRG	QP	AVRG
0.15 - 0.5	66 - 56*	56 - 46*	79	66
0.5 - 5.0	56	46	73	60
5.0 - 30	60	50	73	60

* - The limit decreases linearly with the logarithm of frequency.

7.2.2 Test procedure

7.2.2.1 The EUT was set up as shown in Figure 7.2.1 and the associated photographs, energized and the EUT performance was checked.

7.2.2.2 The measurements were performed at the EUT power terminals with the LISN connected to the EMI receiver in the frequency range referred to in Table 7.2.2. The unused coaxial connector of the LISN was terminated with 50 Ohm.

7.2.2.3 The position of the EUT cables was varied to find the highest emission.

7.2.2.4 The worst test results with respect to the limits were recorded in Table 7.2.2 and shown in the associated plots.

Figure 7.2.1 Setup for conducted emission measurements, table-top EUT

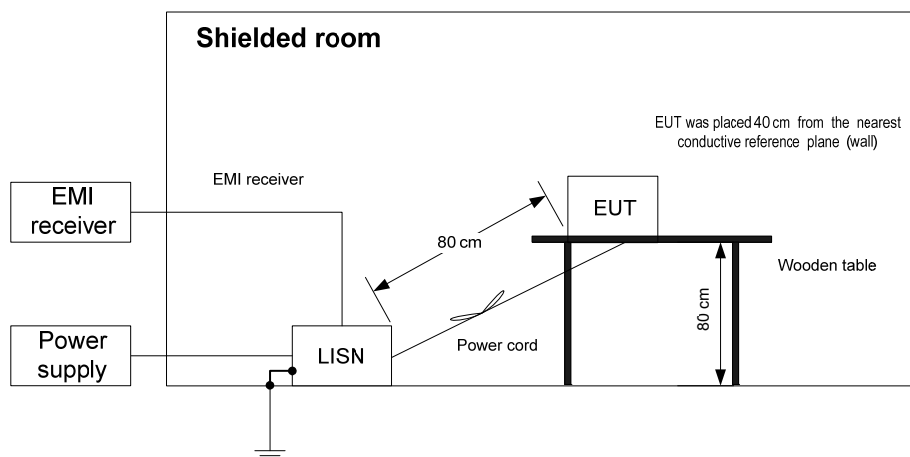



Test specification:		Section 15.207(a), Conducted emission	
Test procedure:		ANSI C63.4, Section 13.1.3	
Test mode:		Compliance	
Date(s):		7/31/2013	
Temperature: 24 °C		Air Pressure: 1007 hPa	
		Relative Humidity: 50 %	
		Power Supply: 120 VAC	
Remarks:			

Table 7.2.2 Conducted emission test results

LINE: AC mains
 EUT SET UP: TABLE-TOP
 EUT OPERATION MODE: Transmit
 TEST SITE: SHIELDED ROOM
 DETECTORS USED: PEAK / QUASI-PEAK / AVERAGE
 FREQUENCY RANGE: 150 kHz - 30 MHz
 RESOLUTION BANDWIDTH: 9 kHz

Frequency, MHz	Peak emission, dB(μV)	Quasi-peak			Average			Line ID	Verdict
		Measured emission, dB(μV)	Limit, dB(μV)	Margin, dB*	Measured emission, dB(μV)	Limit, dB(μV)	Margin, dB*		
1.101558	32.38	26.06	56.00	-29.94	15.42	46.00	-30.58	L1	Pass
5.531190	29.45	27.75	60.00	-32.25	24.07	50.00	-25.93		
8.295448	33.18	31.98	60.00	-28.02	29.11	50.00	-20.89		
23.072344	41.14	40.32	60.00	-19.68	39.61	50.00	-10.39		
25.128288	43.09	40.30	60.00	-19.70	38.09	50.00	-11.91		
1.102535	27.29	22.26	56.00	-33.74	14.30	46.00	-31.70	L2	Pass
5.530100	28.33	26.54	60.00	-33.46	22.85	50.00	-27.15		
8.295270	31.53	29.89	60.00	-30.11	27.15	50.00	-22.85		
23.073195	42.60	41.91	60.00	-18.09	41.27	50.00	-8.73		
25.128680	44.02	41.00	60.00	-19.00	38.87	50.00	-11.13		

*- Margin = Measured emission - specification limit.

Reference numbers of test equipment used

HL 0787	HL 1194	HL 1513	HL 2888	HL 3612			
---------	---------	---------	---------	---------	--	--	--

Full description is given in Appendix A.



HERMON LABORATORIES

Test specification:	Section 15.207(a), Conducted emission		
Test procedure:	ANSI C63.4, Section 13.1.3		
Test mode:	Compliance	Verdict:	PASS
Date(s):	7/31/2013		
Temperature: 24 °C	Air Pressure: 1007 hPa	Relative Humidity: 50 %	Power Supply: 120 VAC
Remarks:			

Plot 7.2.1 Conducted emission measurements

LINE: L1
LIMIT: QUASI-PEAK, AVERAGE
DETECTOR: PEAK



ACTV DET: PEAK
MEAS DET: PEAK OP AVG
MKR 22.82 MHz
41.91 dBµV

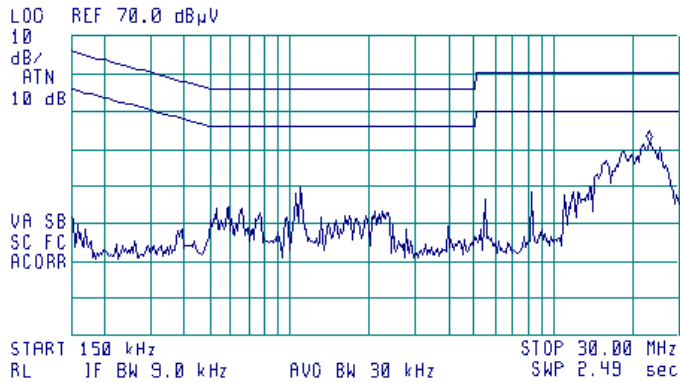

Plot 7.2.2 Conducted emission measurements

LINE: L2
LIMIT: QUASI-PEAK, AVERAGE
DETECTOR: PEAK



ACTV DET: PEAK
MEAS DET: PEAK OP AVG
MKR 22.82 MHz
40.15 dBµV

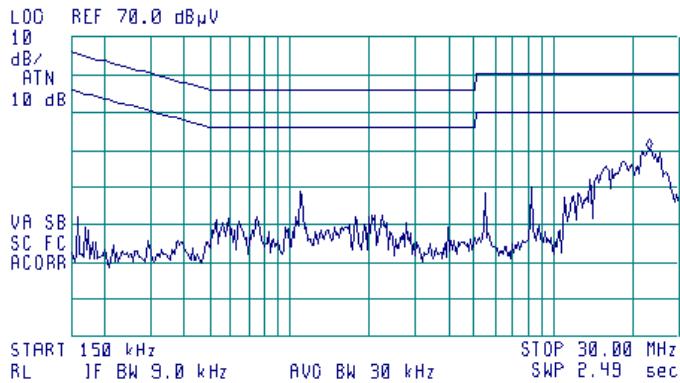



Test specification:	FCC Section 15.203, Antenna requirements		
Test procedure:	Visual inspection/supplier declaration		
Test mode:	Compliance	Verdict:	PASS
Date(s):	8/5/2013		
Temperature: 25 °C	Air Pressure: 1006 hPa	Relative Humidity: 46 %	Power Supply: 120 VAC
Remarks:			

7.3 Antenna requirements

The EUT was verified for compliance with antenna requirements. A transmitter shall be designed to ensure that no antenna other than that furnished by the responsible party will be used with the device. It may be either permanently attached or employs a unique antenna connector for every antenna proposed for use with the EUT. This requirement does not apply to professionally installed transmitters. The rationale for compliance with the above requirements was either visual inspection results or supplier declaration. The summary of results is provided in Table 7.3.1.

Table 7.3.1 Antenna requirements

Requirement	Rationale	Verdict
The transmitter antenna is permanently attached	Visual inspection	Comply
The transmitter employs a unique antenna connector	NA	
The transmitter requires professional installation	NA	

Photograph 7.3.1 Antenna assembly

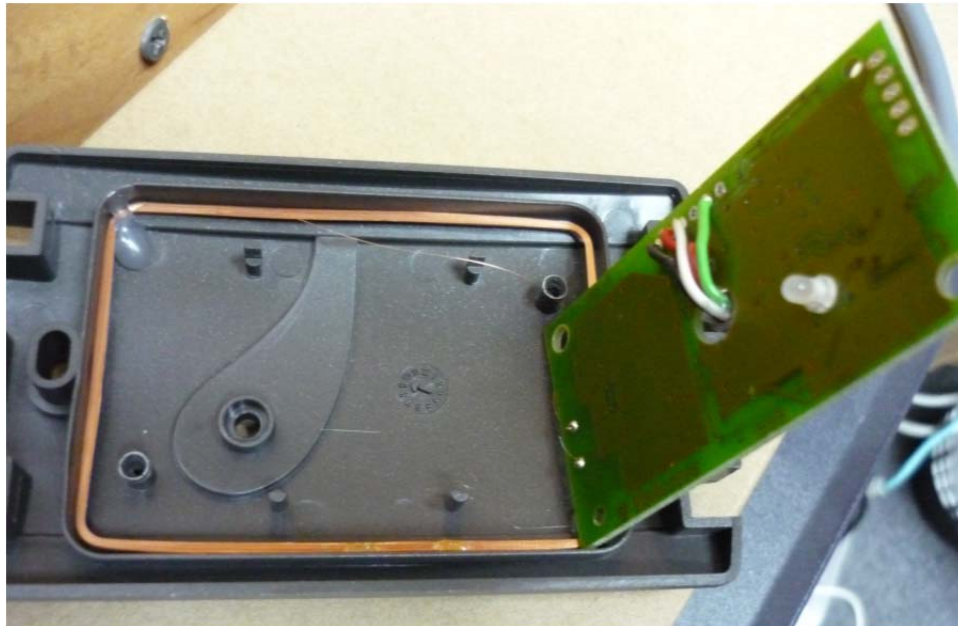

**8 APPENDIX A Test equipment and ancillaries used for tests**

HL No	Description	Manufacturer	Model	Ser. No.	Last Cal./ Check	Due Cal./ Check
0446	Antenna, Loop, Active, 10 kHz - 30 MHz	EMCO	6502	2857	03-Jul-12	03-Jul-14
0604	Antenna BiconiLog Log-Periodic/T Bow-TIE, 26 - 2000 MHz	EMCO	3141	9611-1011	04-Jun-13	04-Jun-14
0787	Transient Limiter 9 kHz-200 MHz	Hewlett Packard	11947A	3107A018 77	15-Oct-12	15-Oct-13
1194	Variac, 220 V/ 2.5 A	Matsunaga	NA	2962	26-May-13	26-May-14
1513	Cable RF, 8 m, BNC/BNC	Belden	M17/167 MIL-C-17	1513	02-Sep-12	02-Sep-13
2871	Microwave Cable Assembly, 18 GHz, 6.4 m, SMA - SMA	Huber-Suhner	198-8155-00	2871	04-Dec-12	04-Dec-13
2888	LISN Two-line V-Network 50 Ohm / 50 uH + 5 Ohm, 16A, MIL STD 461E, CISPR 16-1	Rolf Heine	NNB-2/16Z	02/10018	19-Mar-13	19-Mar-14
3612	Cable RF, 17.5 m, N type-N type	Teldor	RG-214/U	NA	02-Dec-12	02-Dec-13
3818	PSA Series Spectrum Analyzer, 3 Hz- 44 GHz	Agilent Technologies	E4446A	MY482502 88	24-Apr-13	24-Apr-14
4353	Low Loss Armored Test Cable, DC - 18 GHz, 6.2 m, N type-M/N type-M	MegaPhase	NC29-N1N1-244	12025101 003	06-Mar-13	06-Mar-14

9 APPENDIX B Measurement uncertainties

Expanded uncertainty at 95% confidence in Hermon Labs EMC measurements

Test description	Expanded uncertainty
Radiated emissions at 3 m measuring distance	
Horizontal polarization	Biconilog antenna: ± 5.3 dB Biconical antenna: ± 5.0 dB Log periodic antenna: ± 5.3 dB Double ridged horn antenna: ± 5.3 dB
Vertical polarization	Biconilog antenna: ± 6.0 dB Biconical antenna: ± 5.7 dB Log periodic antenna: ± 6.0 dB Double ridged horn antenna: ± 6.0 dB

Hermon Laboratories is accredited by A2LA for calibration according to present requirements of ISO/IEC 17025 and NCSL Z540-1. The accreditation is granted to perform calibration of parameters that are listed in the Scope of Hermon Laboratories Accreditation.

Hermon Laboratories calibrates its reference and transfer standards by calibration laboratories accredited to ISO/IEC 17025 by a mutually recognized Accreditation Body or by a recognized national metrology institute. All reference and transfer standards used in the calibration system are traceable to national or international standards.

In-house calibration of all test and measurement equipment is performed on a regular basis according to Hermon Laboratories calibration procedures, manufacturer calibration/verification procedures or procedures defined in the relevant standards. The Hermon Laboratories test and measurement equipment is calibrated within the tolerances specified by the manufacturers and/or by the relevant standards.

10 APPENDIX C Test laboratory description

Tests were performed at Hermon Laboratories Ltd., which is a fully independent, private, EMC, safety, environmental and telecommunication testing facility.

Hermon Laboratories is listed by the Federal Communications Commission (USA) for all parts of Code of Federal Regulations 47 (CFR 47), Registration Numbers 90624 for OATS and 90623 for the anechoic chamber; by Industry Canada for electromagnetic emissions (file numbers IC 2186A-1 for OATS, IC 2186A-2 for anechoic chamber, IC 2186A-3 for full-anechoic chamber for RE measurements above 1 GHz), certified by VCCI, Japan (the registration numbers are R-808 for OATS, R-1082 for anechoic chamber, G-27 for full-anechoic chamber for RE measurements above 1 GHz, C-845 for conducted emissions site, T-1606 for conducted emissions at telecommunication ports), has a status of a Telefication - Listed Testing Laboratory, Certificate No. L138/00. The laboratory is accredited by American Association for Laboratory Accreditation (USA) according to ISO/IEC 17025 for electromagnetic compatibility, product safety, telecommunications testing and environmental simulation (for exact scope please refer to Certificate No. 839.01). The FCC Designation Number is US1003.

Address: P.O. Box 23, Binyamina 30500, Israel.
Telephone: +972 4628 8001
Fax: +972 4628 8277
e-mail: mail@hermonlabs.com
website: www.hermonlabs.com

Person for contact: Mr. Alex Usoskin, CEO.

11 APPENDIX D Specification references

FCC 47CFR part 15: 2012	Radio Frequency Devices
ANSI C63.2: 1996	American National Standard for Instrumentation-Electromagnetic Noise and Field Strength, 10 kHz to 40 GHz-Specifications
ANSI C63.4: 2003	American National Standard for Methods of Measurement of Radio-Noise Emissions from Low-Voltage Electrical and Electronic Equipment in the Range of 9 kHz to 40 GHz



12 APPENDIX E Test equipment correction factors

Antenna factor
Active loop antenna
Model 6502, S/N 2857, HL 0446

Frequency, MHz	Magnetic antenna factor, dB	Electric antenna factor, dB
0.009	-32.8	18.7
0.010	-33.8	17.7
0.020	-38.3	13.2
0.050	-41.1	10.4
0.075	-41.3	10.2
0.100	-41.6	9.9
0.150	-41.7	9.8
0.250	-41.6	9.9
0.500	-41.8	9.8
0.750	-41.9	9.7
1.000	-41.4	10.1
2.000	-41.5	10.0
3.000	-41.4	10.2
4.000	-41.4	10.1
5.000	-41.5	10.1
10.000	-41.9	9.6
15.000	-41.9	9.6
20.000	-42.2	9.3
25.000	-42.8	8.7
30.000	-44.0	7.5

Antenna factor in dB(1/m) is to be added to receiver meter reading in dB(μ V) to convert it into field intensity in dB(μ V/m).



Antenna factor
Biconilog antenna EMCO Model 3141
Ser.No.1011, HL 0604

Frequency, MHz	Antenna Factor, dB(1/m)
26	7.8
28	7.8
30	7.8
40	7.2
60	7.1
70	8.5
80	9.4
90	9.8
100	9.7
110	9.3
120	8.8
130	8.7
140	9.2
150	9.8
160	10.2
170	10.4
180	10.4
190	10.3
200	10.6
220	11.6
240	12.4
260	12.8
280	13.7
300	14.7
320	15.2
340	15.4
360	16.1
380	16.4
400	16.6
420	16.7
440	17.0
460	17.7
480	18.1
500	18.5
520	19.1
540	19.5
560	19.8
580	20.6
600	21.3
620	21.5
640	21.2
660	21.4
680	21.9
700	22.2
720	22.2
740	22.1
760	22.3
780	22.6
800	22.7
820	22.9
840	23.1
860	23.4
880	23.8
900	24.1
920	24.1

Frequency, MHz	Antenna Factor, dB(1/m)
940	24.0
960	24.1
980	24.5
1000	24.9
1020	25.0
1040	25.2
1060	25.4
1080	25.6
1100	25.7
1120	26.0
1140	26.4
1160	27.0
1180	27.0
1200	26.7
1220	26.5
1240	26.5
1260	26.5
1280	26.6
1300	27.0
1320	27.8
1340	28.3
1360	28.2
1380	27.9
1400	27.9
1420	27.9
1440	27.8
1460	27.8
1480	28.0
1500	28.5
1520	28.9
1540	29.6
1560	29.8
1580	29.6
1600	29.5
1620	29.3
1640	29.2
1660	29.4
1680	29.6
1700	29.8
1720	30.3
1740	30.8
1760	31.1
1780	31.0
1800	30.9
1820	30.7
1840	30.6
1860	30.6
1880	30.6
1900	30.6
1920	30.7
1940	30.9
1960	31.2
1980	31.6
2000	32.0

Antenna factor in dB(1/m) is to be added to receiver meter reading in dB(μ V) to convert it into field intensity in dB(μ V/m).



Correction factor
Line impedance stabilization network
Model NNB-2/16Z, Rolf Heine, HL 2888

Frequency, kHz	Correction factor, dB	
	L	N
150	21.92	21.74
170	21.52	21.36
200	21.06	20.85
250	20.88	20.68
300	20.92	20.70
350	20.96	20.77
400	20.96	20.74
500	20.92	20.69
600	20.85	20.63
700	20.78	20.58
800	20.73	20.52
900	20.68	20.50
1000	20.67	20.45
1200	20.61	20.43
1500	20.56	20.33
2000	20.54	20.32
2500	20.51	20.33
3000	20.53	20.29
4000	20.46	20.30
5000	20.53	20.33
7000	20.54	20.32
10000	20.62	20.36
15000	20.78	20.49
20000	20.94	20.63
30000	21.37	20.95

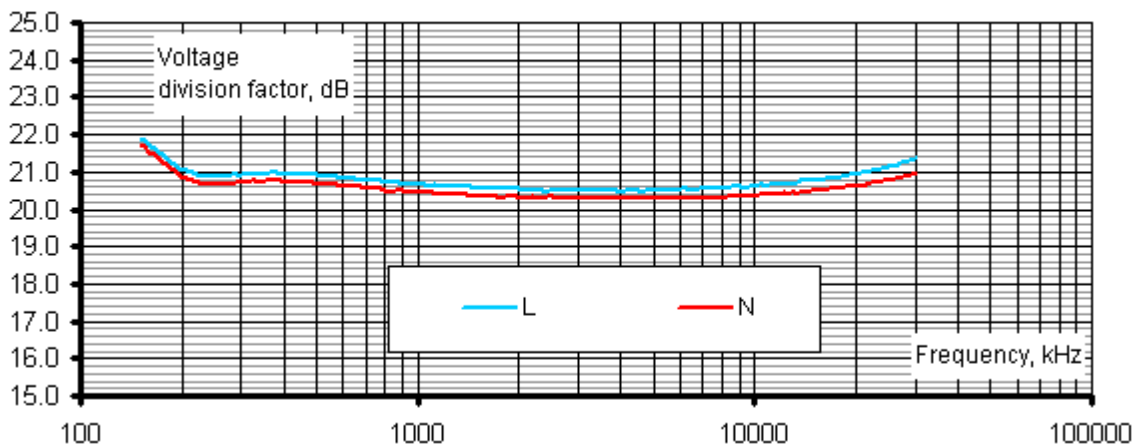



Cable loss
Cable coaxial, Huber-Suhner, 18 GHz, 6.4 m, SMA - SMA, model 198-8155-00,
HL 2871

Frequency, MHz	Cable loss, dB	Frequency, MHz	Cable loss, dB	Frequency, MHz	Cable loss, dB
10	0.12	5750	2.34	12000	3.55
30	0.14	6000	2.39	12250	3.61
100	0.27	6250	2.46	12500	3.67
250	0.45	6500	2.52	12750	3.74
500	0.63	6750	2.58	13000	3.79
750	0.76	7000	2.64	13250	3.82
1000	0.89	7250	2.68	13500	3.83
1250	1.01	7500	2.73	13750	3.83
1500	1.12	7750	2.78	14000	3.88
1750	1.23	8000	2.83	14250	3.93
2000	1.32	8250	2.88	14500	3.96
2250	1.41	8500	2.94	14750	4.01
2500	1.49	8750	2.97	15000	4.00
2750	1.58	9000	3.02	15250	4.01
3000	1.66	9250	3.07	15500	4.00
3250	1.73	9500	3.13	15750	4.13
3500	1.80	9750	3.18	16000	4.22
3750	1.87	10000	3.21	16250	4.29
4000	1.93	10250	3.26	16500	4.29
4250	2.01	10500	3.30	16750	4.32
4500	2.06	10750	3.36	17000	4.37
4750	2.12	11000	3.39	17250	4.45
5000	2.17	11250	3.44	17500	4.49
5250	2.24	11500	3.48	17750	4.53
5500	2.29	11750	3.52	18000	4.55



Cable loss
Cable coaxial, RG-214/U, N type-N type, 17 m
Teldor, HL 3612

Frequency, MHz	Cable loss, dB
0.1	0.05
0.5	0.07
1	0.10
3	0.22
5	0.29
10	0.39
30	0.68
50	0.90
100	1.27
150	1.58
200	1.80
250	2.12
300	2.36
350	2.60
400	2.82
450	2.99
500	3.23
550	3.40
600	3.56
650	3.71
700	3.90
750	4.04
800	4.23
850	4.39
900	4.55
950	4.65
1000	4.79



Cable loss
Low Loss Armored Test Cable, MegaPhase, 18 GHz, 6.2 m, N type-M/N type-M,
NC29-N1N1-244S/N 12025101 003,
HL 4353

Frequency, MHz	Cable loss, dB	Frequency, MHz	Cable loss, dB
50	0.20	9000	2.71
100	0.27	9500	2.81
300	0.47	10000	2.90
500	0.61	10500	2.97
1000	0.87	11000	3.06
1500	1.07	11500	3.13
2000	1.24	12000	3.20
2500	1.39	12500	3.26
3000	1.53	13000	3.34
3500	1.65	13500	3.39
4000	1.77	14000	3.47
4500	1.89	14500	3.54
5000	1.99	15000	3.62
5500	2.07	15500	3.69
6000	2.20	16000	3.76
6500	2.30	16500	3.83
7000	2.39	17000	3.86
7500	2.51	17500	3.94
8000	2.58	18000	4.02
8500	2.65		



13 APPENDIX F Abbreviations and acronyms

A	ampere
AC	alternating current
A/m	ampere per meter
AVRG	average (detector)
cm	centimeter
dB	decibel
dBm	decibel referred to one milliwatt
dB(μ V)	decibel referred to one microvolt
dB(μ V/m)	decibel referred to one microvolt per meter
dB(μ A)	decibel referred to one microampere
DC	direct current
EIRP	equivalent isotropically radiated power
ERP	effective radiated power
EUT	equipment under test
F	frequency
GHz	gigahertz
GND	ground
H	height
HL	Hermon laboratories
Hz	hertz
k	kilo
kHz	kilohertz
LO	local oscillator
m	meter
MHz	megahertz
min	minute
mm	millimeter
ms	millisecond
μ s	microsecond
NA	not applicable
OATS	open area test site
Ω	Ohm
PS	power supply
ppm	part per million (10^{-6})
QP	quasi-peak
RE	radiated emission
RF	radio frequency
rms	root mean square
Rx	receive
s	second
T	temperature
Tx	transmit
V	volt

END OF TEST REPORT

14 APPENDIX G Manufacturer's declaration



Tyco Security Products
23 Habarzel Street
Tel-Aviv 69710, Israel

Tele: +972 3 768 1400
Fax: +972 3 768 1415
www.tycosecurityproducts.com

We, the undersigned,

Company: **Elpas Solutions, Ltd.**, part of the Security Products business unit of Tyco
Address: **23 Habarzel Street, Tel Aviv 69710**
Country: **Israel**
Telephone number: **+972-3-768-1400**
Fax number: **+972-3-768-1415**

certify and declare under our sole responsibility that all devices below are electrically-electronically identical to tested unit RDR-2 Model Number 3-6302-0 :

Part Number	Description	Differences
3-6304-0	Proximity reader RDR-4	Compatible with AXS-100 (Networkable 2-Door controller)
3-6301-2	Proximity reader RDR-1B	Compatible with TIAB KIT2 (Networkable Single Door controller)

Reissued by:	
Tel-Aviv, Israel August 28, 2013	 Michael Wasserstein General Manager

END OF DOCUMENT