

Test Report

for

Electromagnetic Interference

of

E.U.T. : Speedzone Te am Wireless

Trade Name : Dayton

Model Number : SP10506

Prepared for

Dayton Industrial Co., Ltd.

2-12 Kwai Fat Road, 11/F., A, Kwai Chung,

N.T., Hong Kong

TEL. : +852 2422 4404 FAX. : +852 2480 4627

Prepared by

Interocean EMC Technology Co.

No.5-2, Lin 1, Tin-Fu Tsun, Lin-Kou Hsiang,

Taipei County, Taiwan, R.O.C.

TEL. : +886 2 2600 6861

FAX. : +886 2 2600 6859

Caution :

1. No Single part of this report may be reproduced without written permission from Interocean EMC Technology Corp.
2. This test data is traceable to National or International Standards.

Table of Contents

1	General Information	4
1.1	Description of Equipment Under Test	4
1.2	Test Facility	5
2	Power Line Conducted Emission Measurement	6
3	Radiated Emission Measurement (0.009MHz~0.490MHz)	7
3.1	Instrument	7
3.2	Block Diagram of Test Configuration	7
3.3	Radiated Limit	8
3.4	Instrument configuration	8
3.5	Measured Mode	8
3.6	Configuration of Measurement	8
3.7	Configuration of EUT	8
3.8	Test Result	8
4	Radiated Emission Measurement (30MHz~1000MHz)	10
4.1	Instrument	10
4.2	Block Diagram of Test Configuration	10
4.3	Radiated Limit	11
4.4	Instrument configuration	11
4.5	Measured Mode	11
4.6	Configuration of Measurement	11
4.7	Configuration of EUT	11
4.8	Test Result	11
5	Photographs of Measurement	14
5.1	Radiated Emission Measurement (0.009MHz~0.490MHz)	14
5.2	Radiated Emission Measurement (30MHz~1000MHz)	14
6	Photographs of EUT Inside	15

Verification of Compliance

Applicant : Dayton Industrial Co., Ltd.
Manufacturer : Kendy Enterprise Ltd.
EUT Description : Speedzone Team Wireless
Model No. : SP10506
Serial No. : N/A
Tested Power Supply : DC 12V, 3V
Date of Final Test : June 13, 2000
Measurement Procedures and Standards Used : CFR 47, Part 15, Subpart C
 ANSI C63.4: 1992

The device described above was tested by Interocean EMC Technology Corporation to determine the maximum emission levels emanated from the device and severity levels of the device endure and its performance criterion. The measurement results are contained in this test report and Interocean EMC Technology Corp assumes full responsibility for the accuracy and completeness of these measurements. This report shows the EUT is technically compliant with the Part 15 subpart C and ANSI C63.4 official requirements. This report applies to the above sample only and shall not be reproduced in part without written approval of Interocean EMC Technology Corporation.

Report Issued: July 4, 2000

Project Engineer: Jacky Yeh ⁰⁷⁰⁴ 2000
 Jacky Yeh

Checked: Tomy Hu ⁰⁷⁰⁴ 2000
 Tomy Hu

Approved: ~~2000~~ ⁰⁷⁰⁴ 1730
 Kent J.K. Hsu

1 General Information

1.1 Description of Equipment Under Test

Equipment Under Test	: Speedzone Team Wireless
Model Number	: SP10506
Serial Number	: N/A
Type of Sample Tested	: Mass Production
Applicant	: Dayton Industrial Co., Ltd. 2-12 Kwai Fat Road, 11/F., A, Kwai Chung, N.T., Hong Kong
Manufacturer	: Kendy Enterprise Ltd. 2-12 Kwai Fat Road, 11/F., A, Kwai Chung, N.T., Hong Kong
Power Supply	: Battery: 12V for Trasmmitter, 3V for Speedzone Team Meter
Date of Receipt of Sample	: May 18, 2000
Date of Test	: June 13, 2000
Description of E.U.T.	:

The EUT is wireless transmitter speed meter for bicycle. It is mount on the right or the left side of the fork blade. The optimal distance between the computer and the transmitter is 24 inches (610mm). The distance may need to be less then 24 inches (610mm).

1.2 Test Facility

Site Description	:	Anechic Chamber
Name of Firm	:	Interocean EMC Technology Corp.
Site Location	:	No.5-2, Lin 1, Tin-Fu Tsun, Lin-Kou Hsiang, Taipei County, Taiwan, R.O.C.
Site Filing	:	<ul style="list-style-type: none">● Federal Communication Commissions – USA Registration No.: 96399● Voluntary Control Council for Interference by Information Technology Equipment (VCCI) – Japan Registration No. (Conducted Room): C-1094 Registration No. (OATS 1): R-1040 Registration No. (OATS 2): R-1041
Site Accreditation	:	<ul style="list-style-type: none">● Bureau of Standards and Metrology and Inspection (BSMI) – Taiwan, R.O.C. Accreditation No.: SL2-IN-E-0026 for CNS13438 / CISPR22 SL2-A1-E-0026 for CNS13783-1 / CISPR14● National Voluntary Laboratory Accreditation Program (NVLAP) - USA Lab Code: 200458-0

1.2.1 Test Methodology

Both conducted and Radiated Emission Measurement was performed according to the procedures in CFR 47 Part 15 Subpart C and ANSI C63.4: 1992. Radiated Emission Measurement was performed at 3 meters distance from antenna to EUT.

2 Power Line Conducted Emission Measurement

The EUT is a battery-operated equipment; do not need to perform the Power Line Conducted Emission Measurement.

3 Radiated Emission Measurement (0.009MHz~0.490MHz)

3.1 Instrument

Anechoic Chamber

Instrument	Manufacturer	Model	Serial No.	Last Calibration
Spectrum	HP	8591E	3543A04838	2000.01.24
Loop Antenna	EMCO	7405	9011-1836	N/A
Pre-amplifier	Schaffner	CPA9231A/4	3350	1999.12.30
Coaxial Switch	Anritsu	MP59B	6100034527	2000/06/26

Note: All instrument upon which need to calibrated are with calibration period of 1 year.

3.2 Block Diagram of Test Configuration

Configuration of Testing Setup

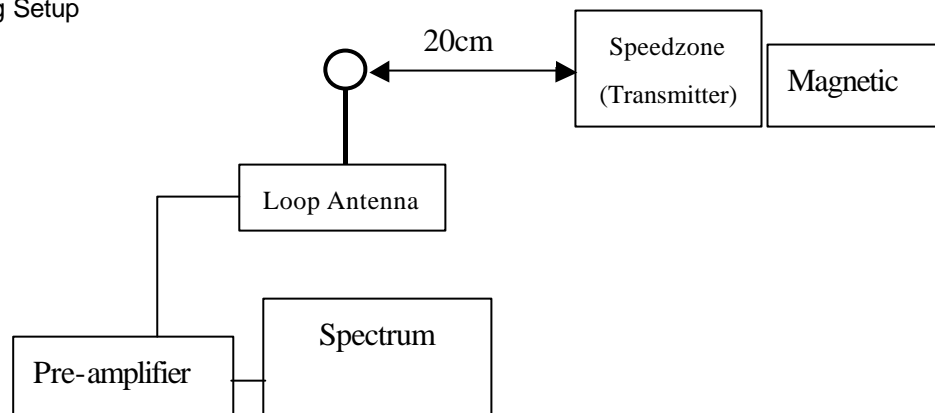

3.3 Radiated Limit

FCC Part 15 Subpart C

Frequency (MHz)	Distance	Field Strength (uV/m)	Average (dBuV/m)
0.009~0.490	300	$2400/F(\text{kHz}) = 19.84$	25.95

3.4 Instrument configuration

- 3.4.1 The EMI test spectrum frequency range set from 100 kHz to 150 kHz.
- 3.4.2 The EMI test spectrum resolution bandwidth set at 100 kHz.
- 3.4.3 The EMI test spectrum video bandwidth set at 300 kHz.
- 3.4.4 The EMI test spectrum detector set as Peak.

3.5 Measured Mode

- 3.5.1 The test mode for preliminary test as following:
 - Mode 1: Tx & Rx
- 3.5.2 Selected the worst case mode when after preliminary test for final test, the mode as following:
 - Mode 1: Tx & Rx

3.6 Configuration of Measurement

- 3.6.1 The EUT was place on a non-conductive table whose total height equaled 80cm.
- 3.6.2 EUT was set 20 cm away from the receiving antenna. Because of the distance between the speed meter (Receiver) and the Transmitter is only 24 inches (610cm). Therefore performed the test at normal test room. And set up the distance between the receiver and transmitter in 20cm.
- 3.6.3 The limit transfer into 20cm is 29760uV/m (89.47 dBuV/m).

3.7 Configuration of EUT

- 3.7.1 Setup the EUT and simulators as shown section 3.2.
- 3.7.2 Trigger the transmitter with magnetic and record the curve with maxim hold of spectrum.

3.8 Test Result

The final tests data as shown on following page.



Interocean EMC Technology Corp.
EMI TESTING DATA

DATE: 06-13-2000
 TIME: 12:38:32

EUT : Cyclocomputer	POLARIZATION: Horizontal
CLIENT: Dayton	TEST DISTANCE: 3 M
MODEL: Speedzone Team Wireless	PROJECT ID: 0A051803
RATING: 12Vdc	FILE/DATA#: Dayton.emi/5
Ser#:	OPERATOR: Kent Hsu
TRACE:	TEST SITE: Chamber 1
	LIMIT :

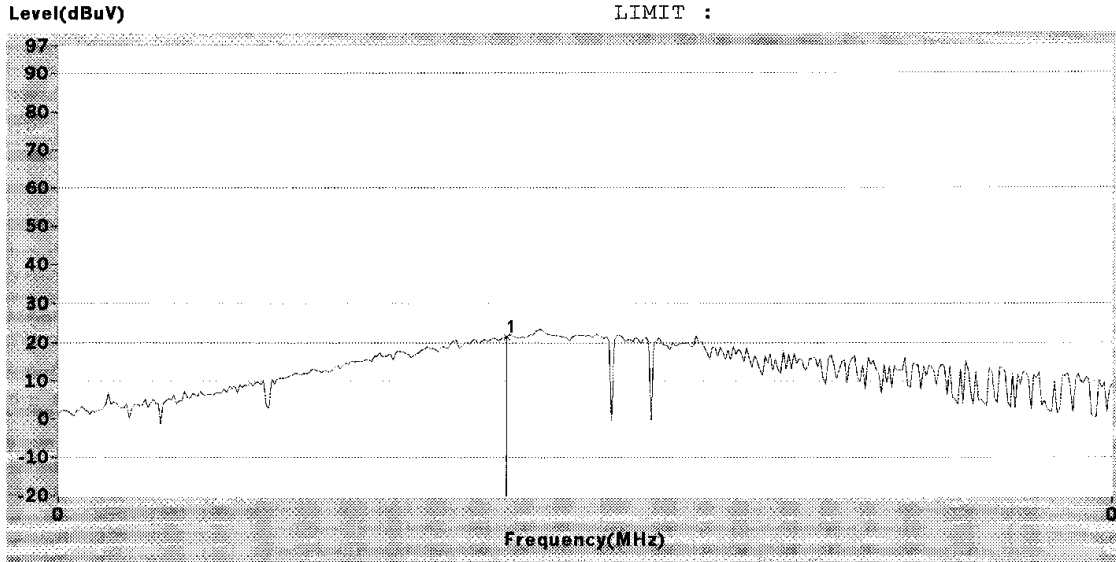

COMMENT :

	Freq	Level	Over	Limit	Read	Antenna	Cable	Other	Remark
	-----	-----	-----	-----	-----	-----	-----	-----	-----
	MHz	dB	dB	dB	dB	dB	dB	dB	
* 1	0.121	21.56	21.56	0.00	51.41	0.00	0.00	29.85	

4 Radiated Emission Measurement (30MHz~1000MHz)

4.1 Instrument

Anechoic Chamber

Instrument	Manufacturer	Model	Serial No.	Last Calibration
Spectrum	HP	8591E	3543A04838	2000.01.24
Bilog Antenna	Schwarzbeck	VULB9161	4023	1999.09.16
Pre-amplifier	Schaffner	CPA9231A/4	3350	1999.12.30
Coaxial Switch	Anritsu	MP59B	6100034527	2000/06/26

Note: All instrument upon which need to calibrated are with calibration period of 1 year.

4.2 Block Diagram of Test Configuration

Configuration of Testing Setup

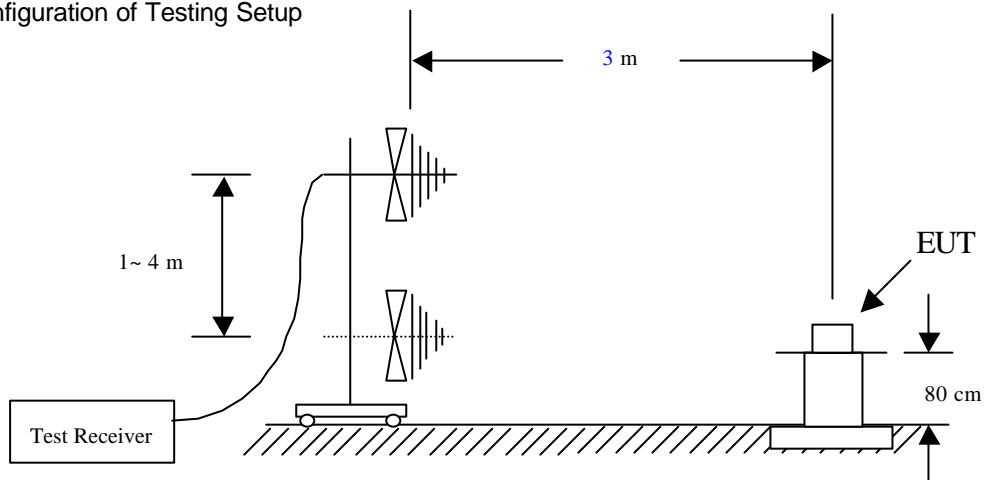

Configuration of EUT Setup

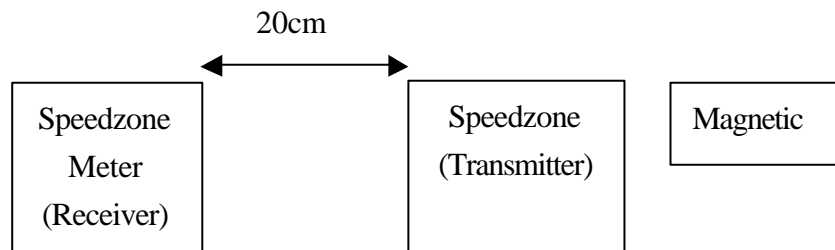

4.3 Radiated Limit

FCC Part 15 Subpart C

Frequency (MHz)	Distance	Field Strength (uV/m)	Quasi-Peak (dBuV/m)
30 ~ 88	3	100	40.00
88 ~ 216	3	150	43.52
216 ~ 960	3	200	46.02
960 above	3	500	53.98

4.4 Instrument configuration

- 4.4.1 The EMI test receiver frequency range set from 30 MHz to 1000 MHz.
- 4.4.2 The EMI test receiver bandwidth set at 120 kHz.
- 4.4.3 The EMI test receiver detector set as Quasi-Peak (Q.P.) and Average (AV).

4.5 Measured Mode

- 4.5.1 The test mode for preliminary test as following:
- Mode 1: Tx & Rx
- 4.5.2 Selected the worst case mode when after preliminary test for final test, the mode as following:
Mode 1: Tx & Rx

4.6 Configuration of Measurement

- 4.6.1 The EUT was place on a non-conductive table whose total height equaled 80cm. The turntable can rotate 360 degree to determine the position of the maximum emission level.
- 4.6.2 EUT was set 3 meters away from the receiving antenna that was mounted on a non-conductive mast. The antenna can move up and down between 1 to 4 meters to find out the maximum emission level.

4.7 Configuration of EUT

- 4.7.1 Setup the EUT and simulators as shown section 3.2.
- 4.7.2 Turn on the power of all equipment.
- 4.7.3 Rotated the magnetic to trigger the Transmitter and emanating the signal.
- 4.7.4 Measured the horizontal polarization and record.
- 4.7.5 Changed into vertical polarization, repeat the procedure as section 3.7.6.

4.8 Test Result

The final tests data as shown on following page.

Radiated Emission Measurement Data

Date of Tested : June 13, 2000 Polarization : Horizontal
 Temperature : 26 Humidity : 49%
 Tested Mode : Tx & Rx

Frequency (MHz)	Antenna Factor (dB/m)	Cable Loss (dB)	Meter Reading (dBuV)	Emission Level (dBuV/m)	Limits (dBuV/m)	Margin (dB)
30.000	3.54	0.85	14.77	22.16	40.00	-20.84
59.100	13.22	1.05	5.85	20.12	40.00	-19.88
117.300	10.20	1.44	9.81	21.45	43.50	-22.06
136.700	14.78	1.50	4.41	20.69	43.50	-22.82
158.525	18.92	1.58	2.17	22.67	43.50	-20.82
170.650	17.32	1.64	1.88	20.84	43.50	-22.66

Remark :

1. All readings are Peak values. Because all emission are too low. Therefore performed the test in anechoic chamber.

Radiated Emission Measurement Data

Date of Tested : June 13, 2000 Polarization : Vertical
 Temperature : 26 Humidity : 49%
 Tested Mode : Tx & Rx

Frequency (MHz)	Antenna Factor (dB/m)	Cable Loss (dB)	Meter Reading (dBuV)	Emission Level (dBuV/m)	Limits (dBuV/m)	Margin (dB)
30.000	5.76	0.85	13.30	19.91	40.00	-20.09
59.100	12.79	1.05	13.48	27.33	40.00	-12.67
83.350	8.07	1.21	10.37	19.65	40.00	-20.35
117.300	12.29	1.44	12.22	25.94	43.50	-17.56
134.275	15.00	1.48	6.01	22.49	43.50	-21.01
471.350	26.95	2.61	2.03	31.59	46.00	-14.41
561.075	14.98	2.81	6.99	24.78	46.00	-21.22

Remark :

- All readings are Peak values. All emissions are too low. Therefore performed the test in anechoic chamber.

5 Photographs of Measurement

5.1 Radiated Emission Measurement (0.009MHz~0.490MHz)

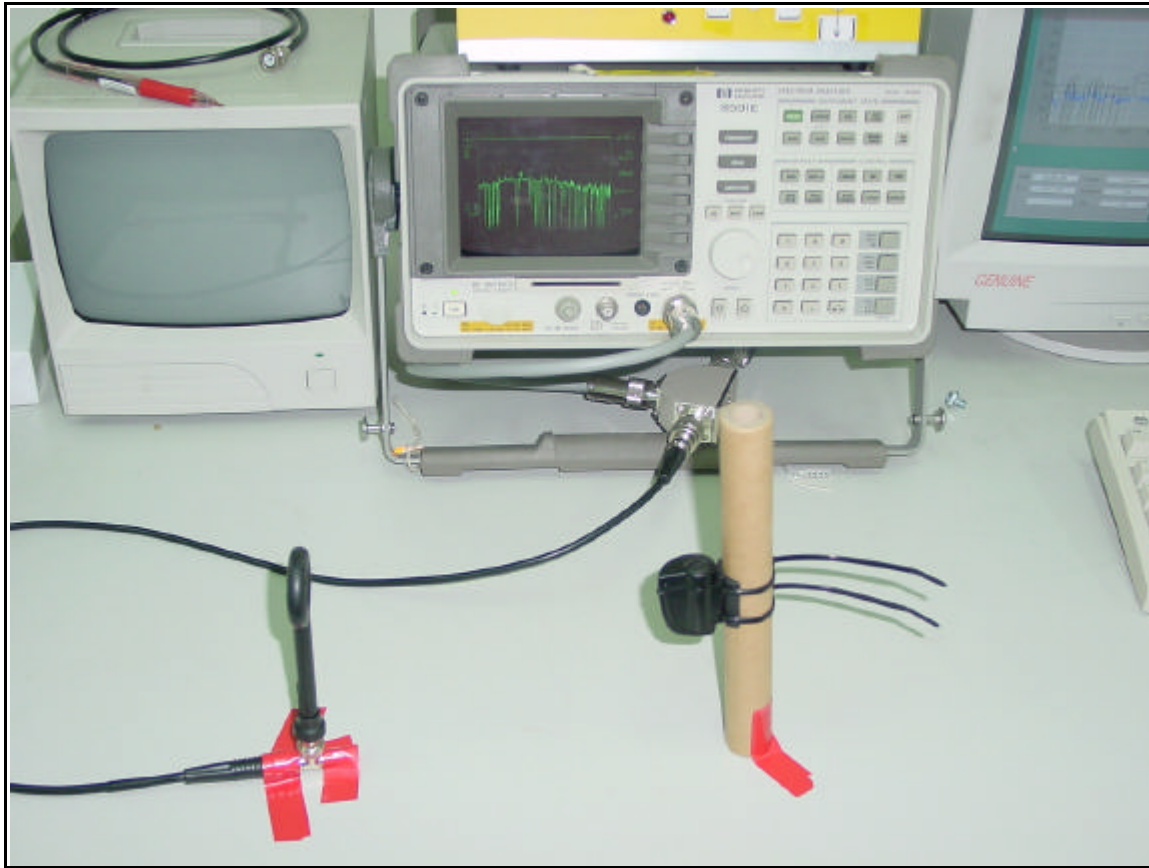

5.2 Radiated Emission Measurement (30MHz~1000MHz)



6 Photographs of EUT Inside



Front View of Appearance (Transmitter)



Rear View of Appearance (Transmitter)

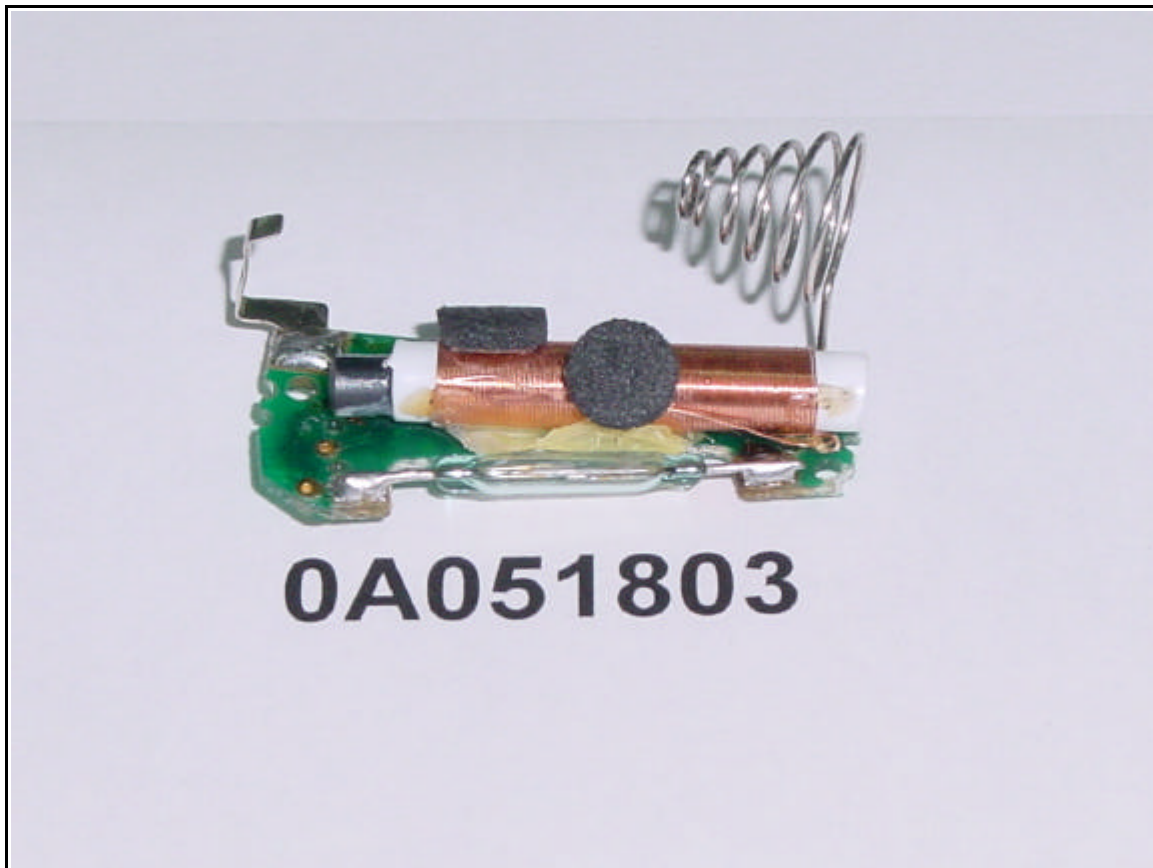

Transmitter Inside 1

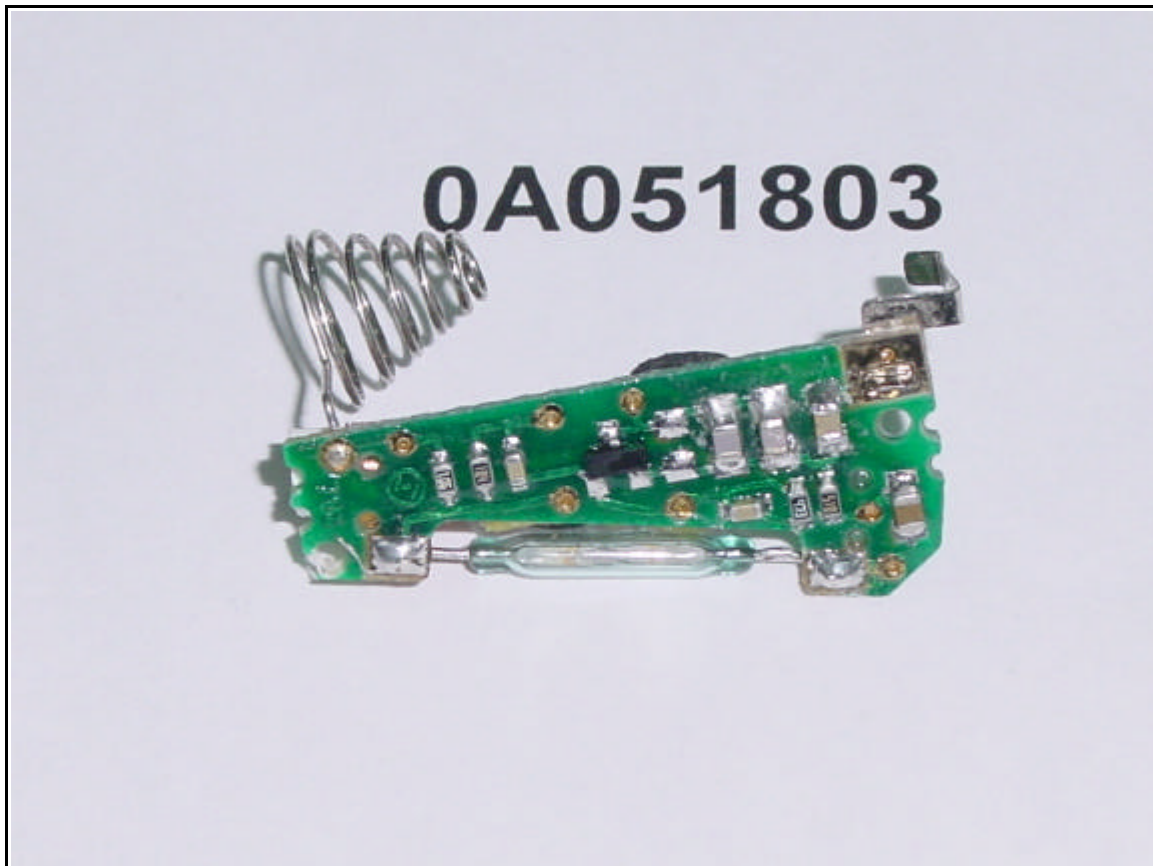

Transmitter Inside 2



Front View of Appearance (Receiver)



Front View of Appearance (Receiver)

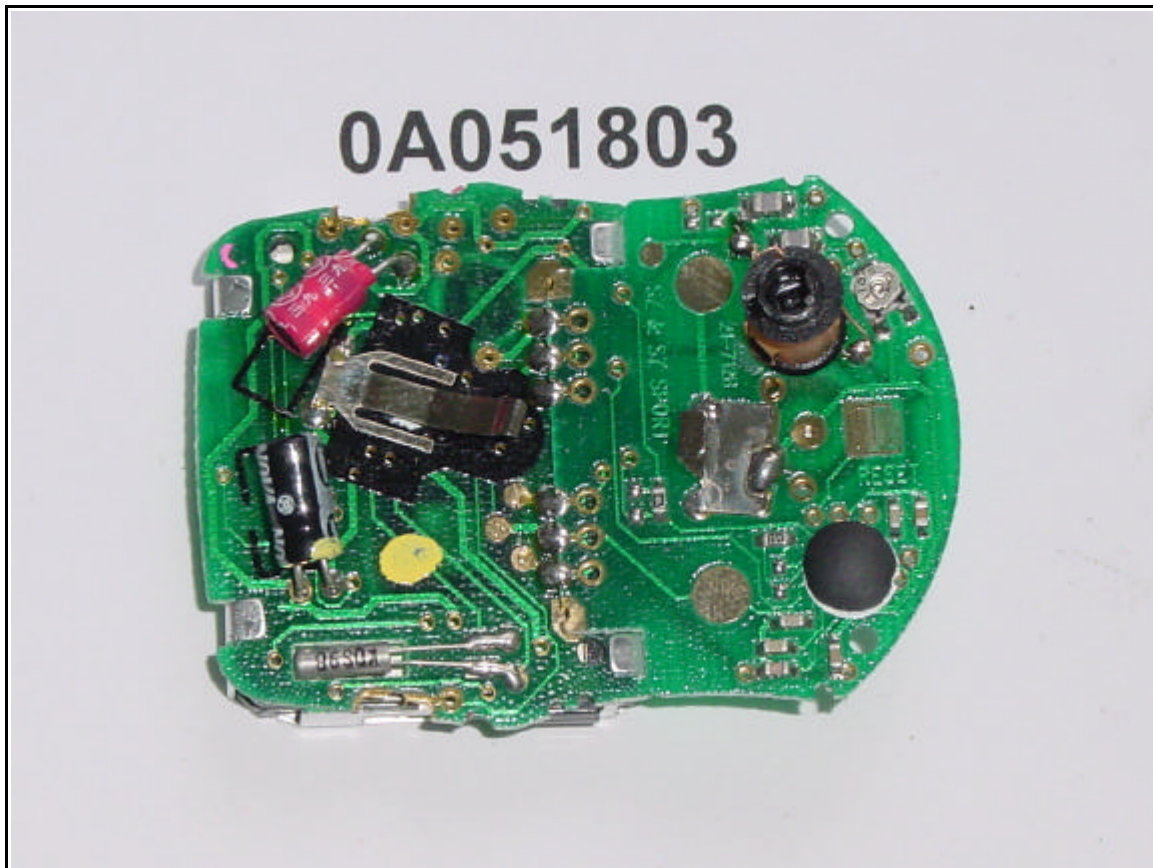

Receiver inside 1



Receiver inside 2

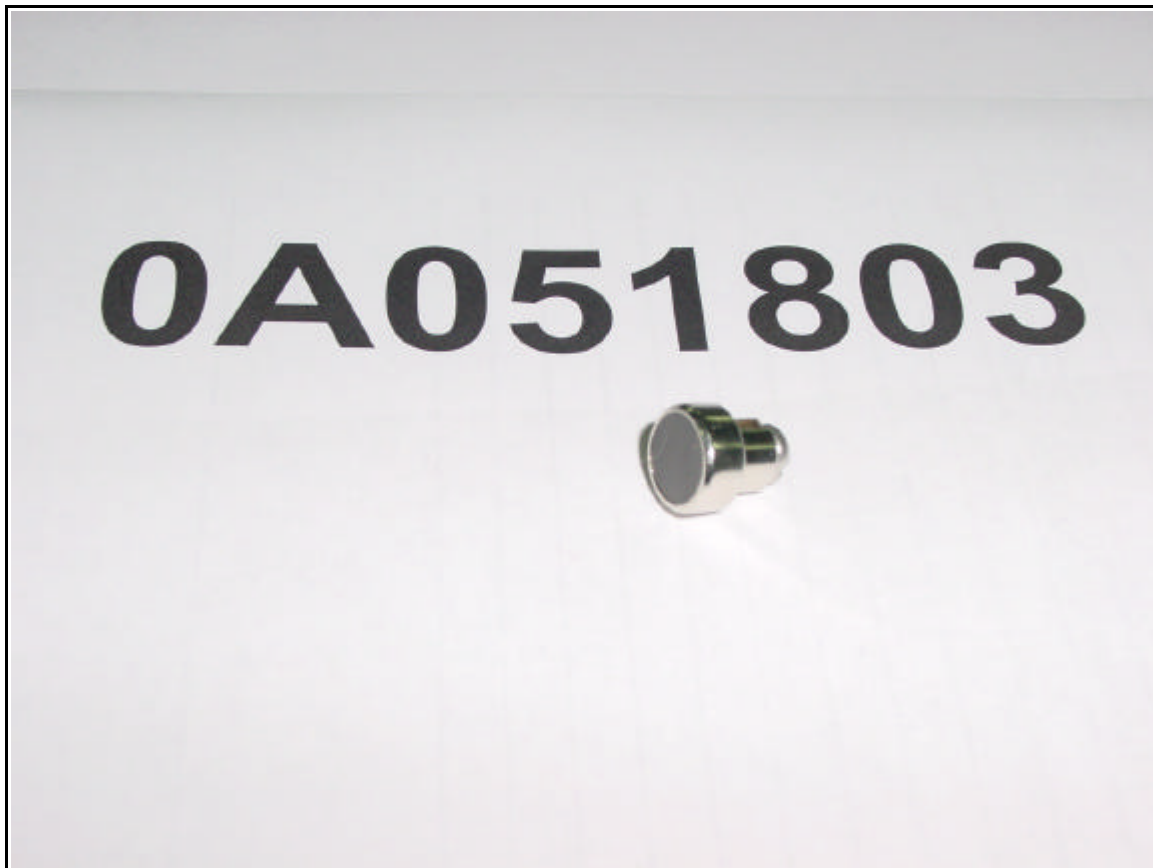

Magnetic