

A B C D E

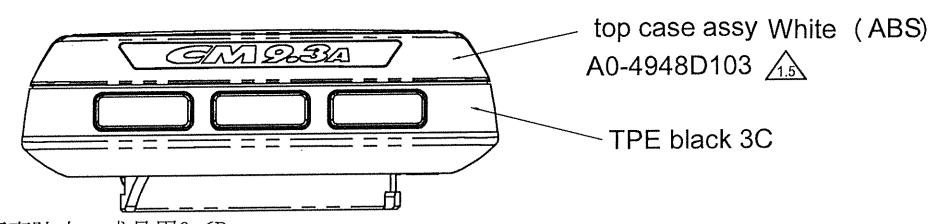
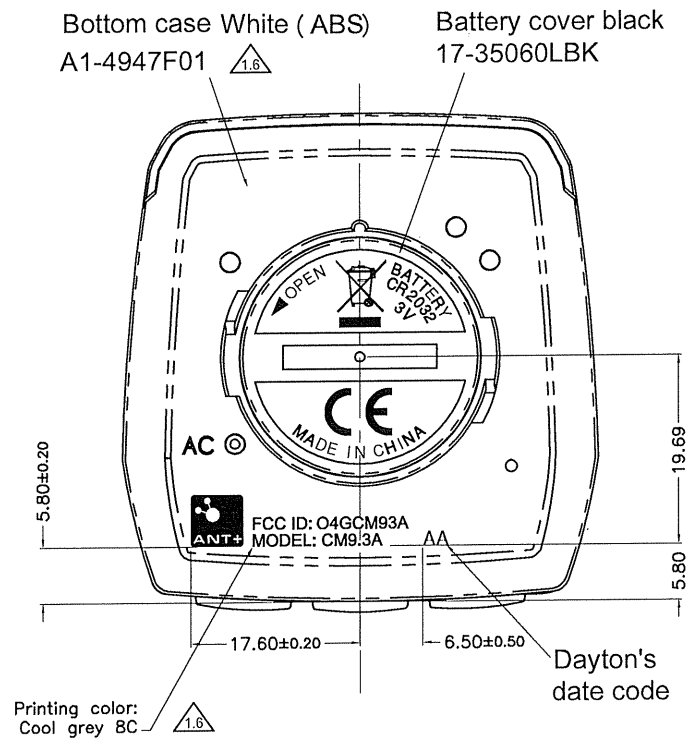
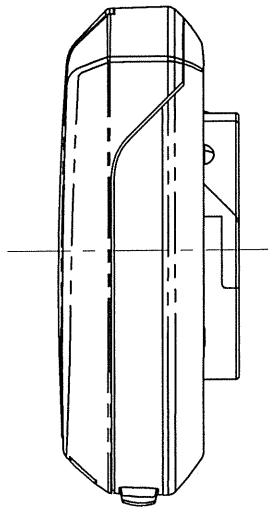
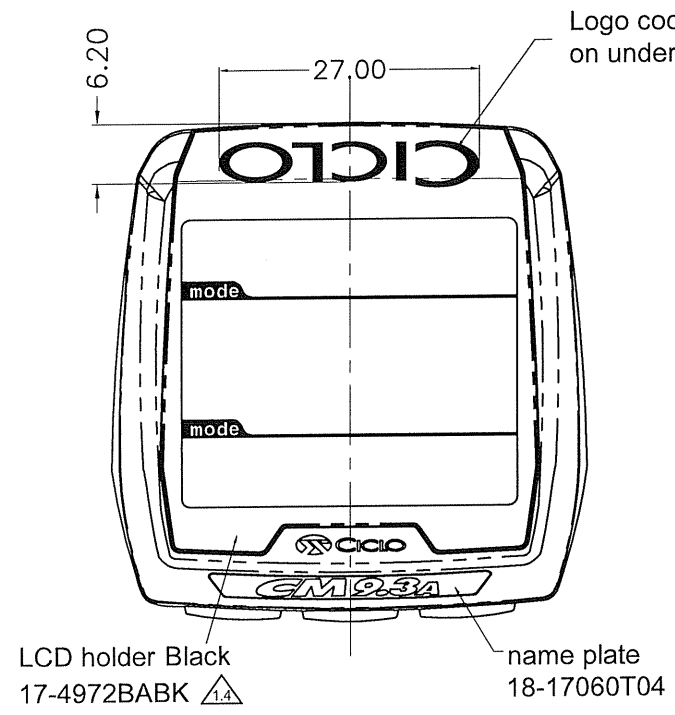

產品要求:
 防水測試: 用1Bar內壓試面亮防水, 成品用0.6Bar.
 絲印黏附力測試: 用3M透明膠紙(#600)壓貼在表面拉3次.
 UV測試: 放在UV燈箱內72小時不可出現明顯變色.
 須符合Rohs及Reach的安全規格.

1.6	Add FCC logo on case back $\Delta_{1.6}$	31/10/13	DAYTON INDUSTRIAL CO. LTD. KENDY ENTERPRISE LTD.			LINEAR \pm 0.1
1.5	change printing and p/n $\Delta_{1.5}$	23/9/2013				ANGULAR \pm 3°
1.4	change printing and p/n $\Delta_{1.4}$	8/8/2013	TITLE: cosmetic drawing	MODEL NAME: CM9.3A	VERSION NO: 1.6	
1.3	change p/n $\Delta_{1.3}$	14/5/2013	PART NO: B9-CS2010000	MODEL NO: CS20100	DATE: 31/10/2013	
1.2	change colour $\Delta_{1.2}$	25/3/2013	MAT'L: ABS	SCALE: 1:1	DOC CONTROL NO: 004-9060	SHEET 1 of 1
REV.	REVISIONS $\Delta_{1.0}$	DATE	FINISH:	QTY: 1	DWN δ	CHKD

A B C D E

1
2
3
4

1
2
3
4