

A

B

C

D

E

1

1

2

2

3

3

4

4

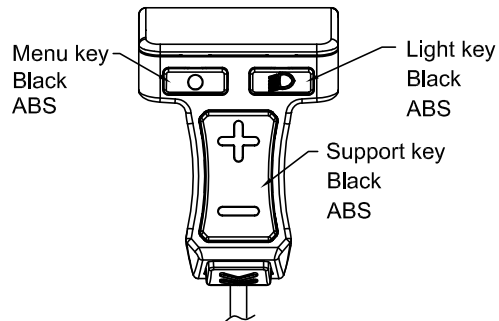
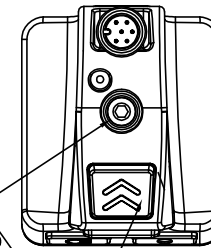
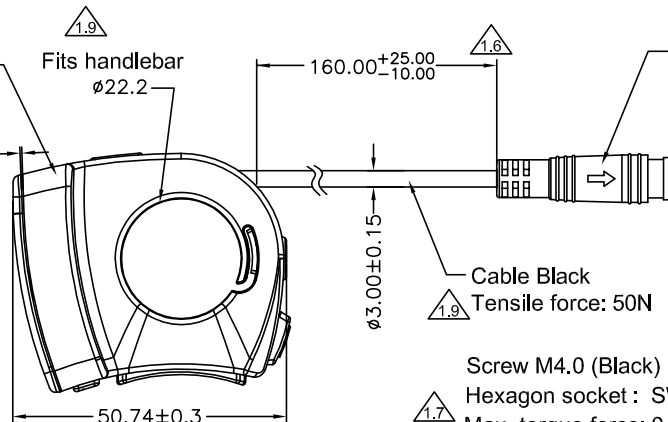
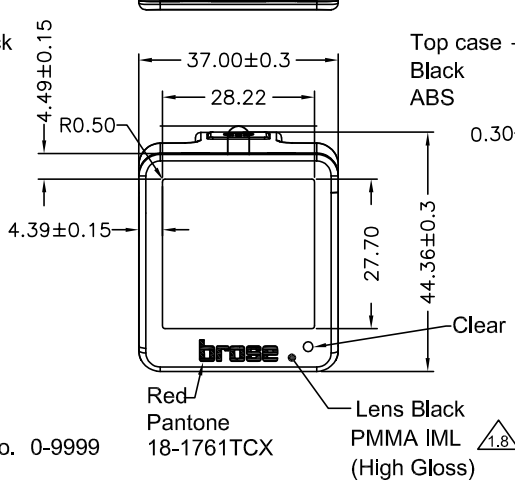
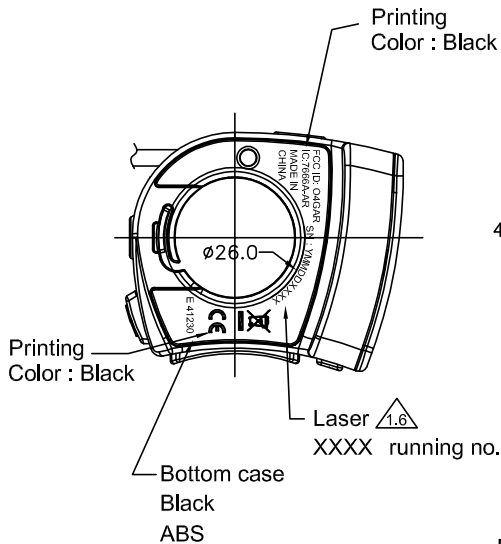
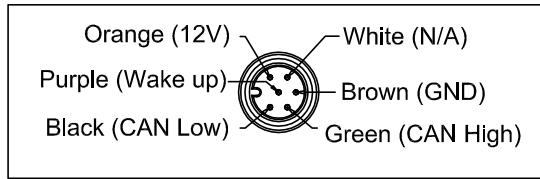
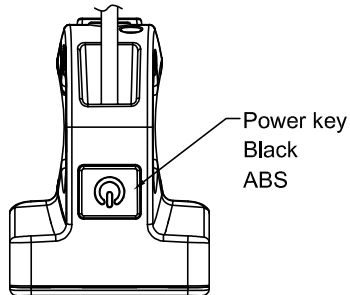

ALL DIMENSIONS IN MM

Remarks:

- Estimated weight: 36g ^{1.6}
- Housing and buttons complete with grain (TR13) ^{1.7}
- No glossy marks
- Cleanliness: no visible particle inside on lens
- IPX7
- No condensation inside on lens at low temperature ^{1.8}
- Locking screw must not move freely in housing
- No visible and non removable dust and scratch on unit ^{1.9}
- Lens with protection film covered ^{2.0}

REV.	REVISIONS	DATE
2.0	Remarks updated	29/10/2019
1.9	Remarks added	26/09/2019
1.8	Lens material changed	15/08/2019
1.7	Add remarks	13/08/2019
1.6	Cable length changed, weight updated SN number format changed	11/06/2019

DAYTON INDUSTRIAL CO. LTD.
KENDY ENTERPRISE LTD.

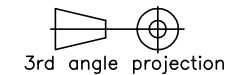

LINEAR ± 0.10
ANGULAR ± 1'
UNSPECIFIED TOLERANCE

TITLE: COSMETIC DRAWING		MODEL NAME: Allround E41230-101		VERSION NO: 2.0
PART NO: B9-BR4410000		MODEL NO: BR44100		DATE: 29/Oct/2019
MAT'L: Specified in the parts	SCALE:	DOC CONTROL NO: DG00-3076		SHEET 1 OF 1
FINISH: Specified in the parts	QTY: 1	DWN	CHKD	APPD

A

B

C

D

E