



ShenZhen C&D Electronics CO.Ltd.

www.cn-cdrc.com cdrc@cdrc.sina.net
C&D ELECTRONICS

Add: Building 2, Xiayousong Mountaintop Industrial District, Yousong Village, LongHua Town, Baoan District ShenZhen China Zip 518109

Tel: 86-755- 28142422 Fax: 86-755-28142699 E-mail: export@cn-cdrc.com

Remote control specification

文件编号 **document series number:**

产品名称 product name	2.4G 遥控器 remote control
产品型号 product model	RF339
批准 approval	/日期 date
审核 checked	/日期 date
拟制 made	/日期 date

客户确认（盖章） **customer approval**

客户名称 customer	审核 check	批准 approval
DEWERT		

版本记录 **version record:**

version	date	name	remark
V0.1	2015-7-20		初稿 draft

2、目录 Index

NO.	appellation
1	规格书封面 (Approval Sheet Cover)
2	目录 (Index)
3	检验内容及要求 (Verification content & Requirement)
4	产品效果图 (Product Cosmetics drawing)
5	无线发射距离 (RF transmit distance)
6	软件功能 (software function)
7	原理图(Schematic diagram)
8	爆炸图 (Explosion drawing)
9	尺寸图 (dimension drawing)
10	包装图 (packing drawing)



3. 检验内容及要求 (Verification content & Requirement)

1、 一般项目 (General Items)

- 1.1、 适用范围 Apply for: RF339
- 1.2、 工作环境 Working Environment: 0°C~40°C、 8%~90% RH
- 1.3、 存储温度 Storage Environment: -40°C~70°C, 5%~90% RH
- 1.4、 试验环境 Test Environment: 5°C~35°C、 45%~75% RH、 86~106Kpa
- 1.5、 额定电压 Rating Voltage: DC4.5V
- 1.6、 适用电池 Power: AAA*3 pcs
- 1.7、 重量范围 Weight: 145g

2、 可视检测项目 Visible Test Item

测试条件 Test Conditions

A: 正面在标准光源下 30CM 距离 10 秒以内目测 Put the top face under the standard light source and test by sight from the 30cm distance for 10 seconds

B: 其余面标准光源下 50CM 距离 5 秒以内目测 Put other sides under the standard light source and test by sight from the 50cm distance for 5 seconds

序号 No.	项目 Item	测试要求 Test Requirements
2.1	划伤、沾污、割裂、变形 Scratches, Stain and distortion of the Unit	无上述各种现象 No described situations
2.2	印刷图形及文字 Hot Stamped Graphics and Letters	内容正确、清晰、均匀、整齐 Correct, in focus and comply with the drawing
2.3	壳体配合 Match of top case and bottom case	无翘起、变形、开裂、断差 No distortion and Crack between the twoparts
2.4	表面 Appearance	材质正确、颜色一致 Correct material and color

3、 电气性能 Electric Capability

序号	项目	测试要求 Test Requirements
3.0	主控芯片 IC	nordic NRF24LE1
3.2	工作电压 Working Voltage	DC4.5V
3.3	待机电流 Static Current	<10uA
3.4	工作电流 Working Current	按键时工作电流 ≤ 30mA



3.7	工作原理图 Schematic Diagram	详见工作原理图 Refer to Schematic Diagram
-----	----------------------------	------------------------------------

3.11	载波频率偏移	偏移 ± 150KHz
3.12	天线增益	0dB
3.15	性能测试 Actual performance test	每个按键需操作有效 No Failure in each key Operation

3.2 机械性能 Mechanical Capacity

序号 No.	项目 Item	测试要求 Test Requirements
4.1	跌落测试 Drop Test	80CM 高度 6 面各一次, 自由跌落至厚度 3CM 硬质木板上, 再行检测: a、接受电池和卡套与产品分离 b、重装电池后功能正常 c、结构无损伤 d、上述电气性能正常 Drop the 6 faces of the bare unit from the height of 80cm of the steel which is 3cm thick and test: A> the battery separate from the remote is acceptable. B> the remote works well after reinstall. C> no damages on mechanical. d. the above electronic capacity work well
4.2	振动测试 Vibration Test	水平和垂直方向, 每个方向两种频率各 5 个循环: a、频率 10~30~10Hz 位移距离 0.75mm b、频率 30~55~30Hz 位移距离 0.15mm, 测试后检测结构无损伤, 电气性能正常 5 recycle of 2 frequencies in the horizontal and vertical direction: a. frequency 10~30~10Hz to move 0.75mm. b. frequency 30~55~30Hz to move 0.15mm, no damages in mechanical and electronic capacity
4.3	喷油丝印附着力测试 Print a Adhesion Test	1. 3M 胶纸 (600) 5 次无脱落现象 3M tape(600) 5 times, the print is complete 2. RCA 测试:以 225gf 力测试纸带长度 100CM 无脱落现象 RCA test: use 225gf force, 100CM length tape, the print is complete
4.4	喷油丝印耐腐蝕测试 Print corrosion test	1. 用棉布浸泡 99%工业酒精 1min,500gf 来回 20 次擦试无脱落现象 Sink the cotton in 99% alcohol 1 minutes with 500 gf for to scrub the print 20 time
4.5	声音要求 Sound Request	遥控器晃动是不能有异响。 There shall be no rattling when the remote is shaken.



3.3 环境测试 Environmental Test

序号 No.	项目 Item	测试要求
5.1	操作温度 Operating Temperature	遥控器在 0°C~ +40°C 环境下可以正常操作。 The RCU shall be capable of operating in an ambient temperature range of 0°C to +40°C.
5.2	操作湿度 Operating Humidity	遥控器在 8%~90%湿度环境下可以正常操作,不冷凝。 The device shall be capable of operating in a relative humidity range of 8% to 90%, non-condensing.
5.3	存放温度 Storage Temperature	遥控器在放置于 -40°C ~ +70°C 的高低温环境后仍可正常操作。 The RCU shall be capable of operating after being stored in an ambient temperature range of -40°C to +70°C.
5.4	存放湿度 Storage Humidity	遥控器在放置于 5%~ 90%的湿度环境后仍可正常操作。 The RCU shall be capable of operating after being stored in a relative humidity range of 5% to 90%, non-condensing.

3.4 产品认证 Compliant

序号 No.	项目 Item	规格 Specs
6.1	FCC	FCC ID 认证
6.2	IC	IC ID 认证



4. 产品效果图 ID drawing

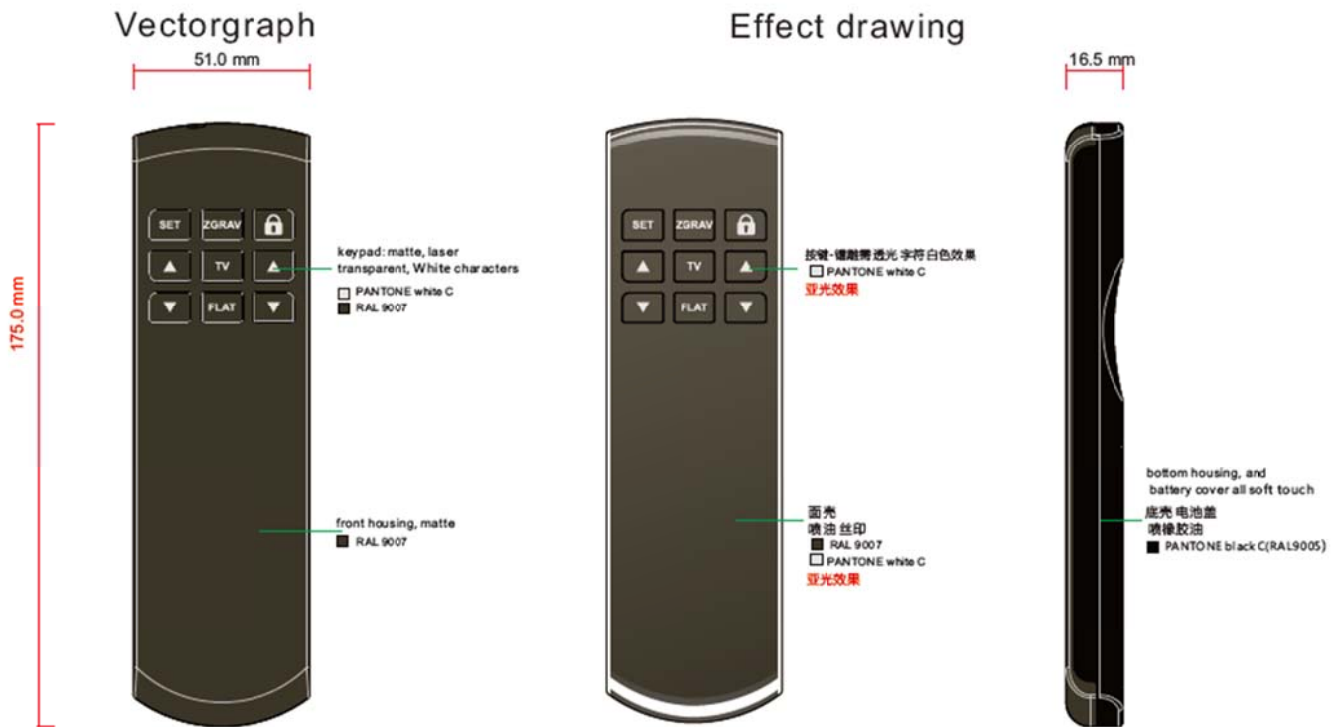

C&D 深圳创荣发电子有限公司 SHENZHEN CAD ELECTRONICS CO., LTD.			
Client model No. 客户型号		Version No. 版本	1.5
C&D Model No. 内部型号	RF181-81634	Scale 比例	1:1
Made By. 制作	周培良	Date 日期	2015-05-22

5. 无线距离 distance:

RF distance 距离	
直线距离 direct distance	15m
非直线距离 indirect distance	10m



6、功能 function test:

1、配对 pairing:

设备正确连接后，连续按下两次配对键，此时 RF181B 接收器上的绿色指示灯会亮起。然后在 RF339(RF187A)发射器上同时按下 S20 键进行配对。配对成功后，RF339(RF187A)发射器上的 LED 灯和 RF181B 接收器上的绿色指示灯会同时熄灭。此时，设备已经成功配对。

Afrer connecting, to pressed the pairing button continuously for two time on RF181B, and the indicator lights,then press the button S20 on RF339(RF187A) to pair with this receiver,if both the green LED indicator on RF181B and the pairing indicator on RF339(RF187A) will be off at the same time,the pairing is successful.

2. 按键测试 button test

	按键	功能描述
	1	按下 S2 按键，背景灯亮。 The keypad backlight is on
	2	如左图循环按下按键，发出短暂的 BEEPER 声，为良品。 Press all keys once (except for S1) in the order shown on the left pictures attached (From left to right and from up to down) , a short beep (200ms) will occur, that is pass the test.



--	--	--

7、遥控器原理图 Schematic diagram :

7.1 原理图 Schematic diagram

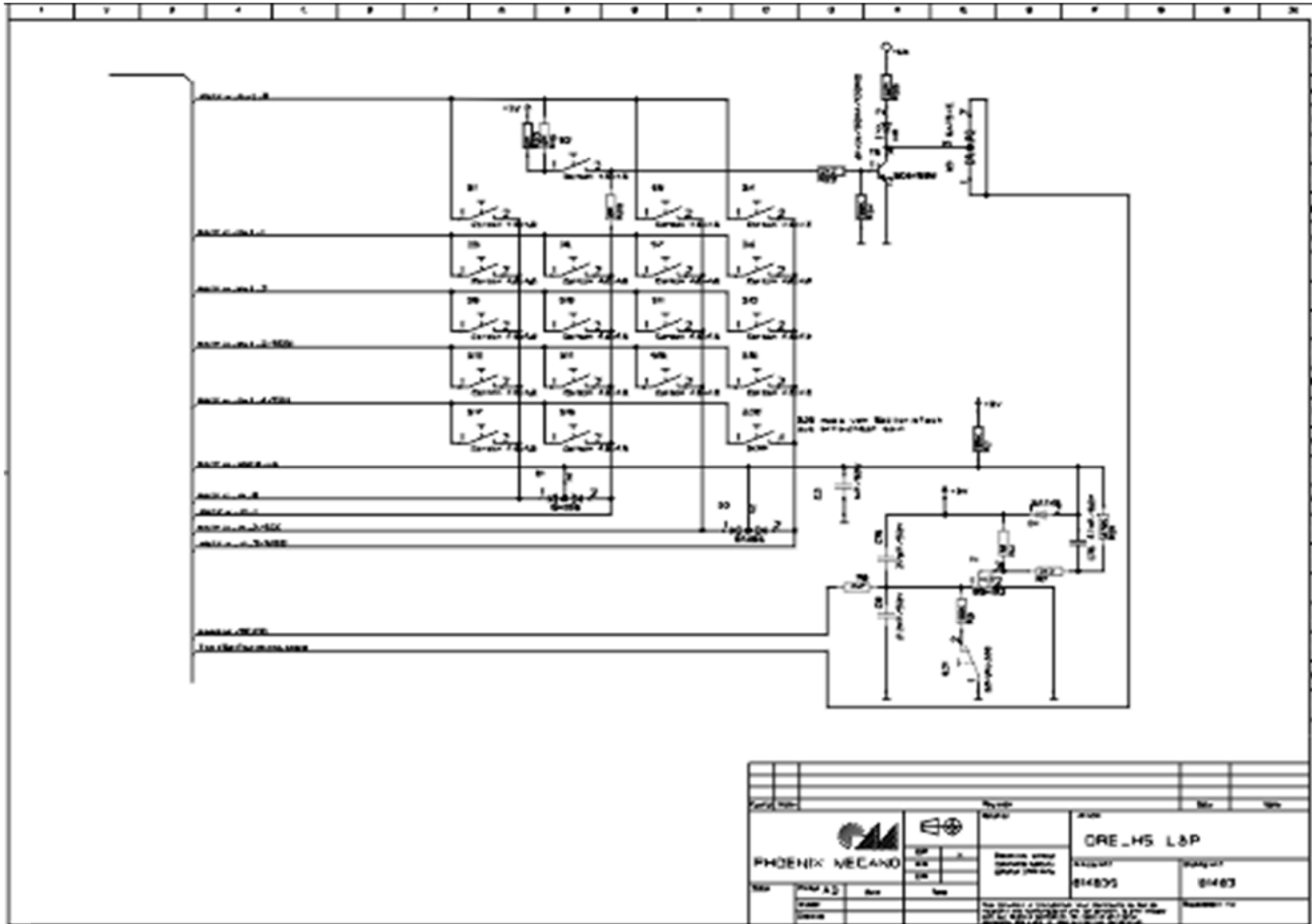



7.2 Connecting Plan

It's not allowed to glue labels etc. on both sides

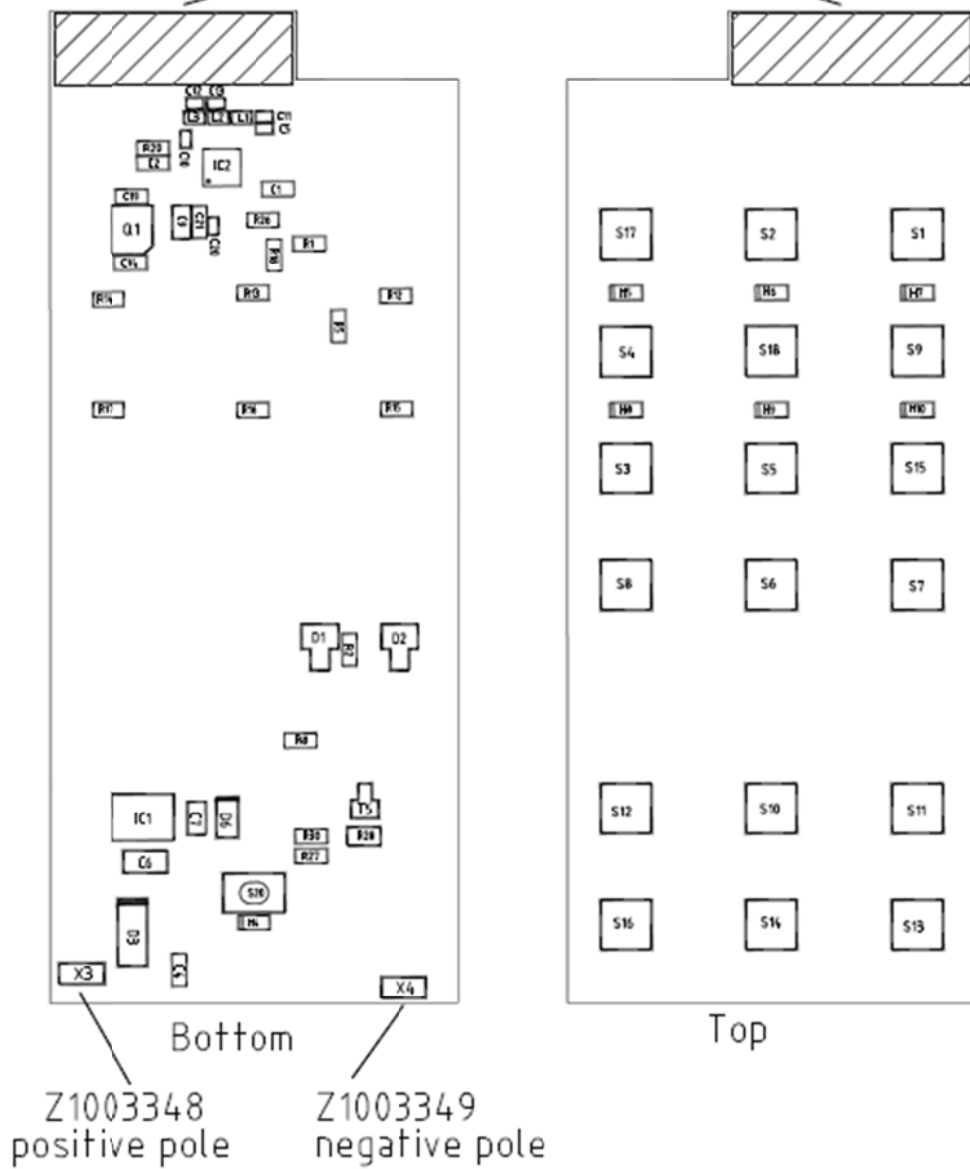



深圳市创荣发电子有限公司
SHENZHEN C&D ELECTRONICS CO., LTD.

FCC Warning / IC Warning

FCC: This device complies with Part 15 of the FCC Rules. Operation is subject to the following two conditions: (1) this device may not cause harmful interference, and (2) this device must accept any interference received, including interference that may cause undesired operation.

Note: Any changes or modifications not approved by the party responsible for compliance could void the user's authority to operate the equipment.

IC: This device complies with Industry Canada RSS-210 standard(s). Operation is subject to the following two conditions: (1) this device may not cause interference, and (2) this device must accept any interference, including interference that may cause undesired operation of the device."

Le présent appareil est conforme aux CNR d'Industrie Canada applicables aux appareils radio Exempts de licence. L'exploitation est autorisée aux deux conditions suivantes: (1) l'appareil ne doit pas produire de brouillage, et (2) l'utilisateur de l'appareil doit accepter tout brouillage radioélectrique subi, même si le brouillage est susceptible d'en compromettre le fonctionnement."