

Application for FCC Certification  
On behalf of

Philips (China) Investment Co., Ltd.

Product Name: LED LAMPS

Model No.: 9290002265

FCC ID: O3M9290002265X

Prepared For : Philips (China) Investment Co., Ltd.  
No.9, Lane 888, Tian Lin Road, 200233, Shanghai,  
China

Prepared By : Audix Technology (Shanghai) Co., Ltd.  
3F 34Bldg 680 Guiping Rd.,  
Caohejing Hi-Tech Park,  
Shanghai 200233, China

Tel: +86-21-64955500  
Fax: +86-21-64955491

Report No. : ACI-F13024  
Date of Test : Feb. 01 - 22, 2013  
Date of Report : Mar. 13, 2013

## TABLE OF CONTENTS

	Page
<b>1 SUMMARY OF STANDARDS AND RESULTS</b> .....	<b>5</b>
1.1 Description of Standards and Results.....	5
<b>2 GENERAL INFORMATION</b> .....	<b>6</b>
2.1 Description of Equipment Under Test.....	6
2.2 Description of Test Facility.....	7
2.3 Measurement Uncertainty.....	7
<b>3 CONDUCTED EMISSION TEST</b> .....	<b>8</b>
3.1 Test Equipment.....	8
3.2 Block Diagram of Test Setup.....	8
3.3 Conducted Emission Limit [FCC Part 15 Subpart B 15.207].....	8
3.4 Test Configuration.....	9
3.5 Operating Condition of EUT.....	9
3.6 Test Procedures.....	9
3.7 Test Results.....	9
<b>4 RADIATED EMISSION TEST</b> .....	<b>11</b>
4.1 Test Equipment.....	11
4.2 Block Diagram of Test Setup.....	11
4.3 Radiated Emission Limit [FCC Part 15 Subpart C 15.209].....	12
4.4 Test Configuration.....	12
4.5 Operating Condition of EUT.....	12
4.6 Test Procedures.....	12
4.7 Test Results.....	14
<b>5 6 dB BANDWIDTH MEASUREMENT</b> .....	<b>27</b>
5.1 Test Equipment.....	27
5.2 Block Diagram of Test Setup.....	27
5.3 Specification Limits (§15.247(a)(2)).....	27
5.4 Operating Condition of EUT.....	27
5.5 Test Procedure.....	27
5.6 Test Results.....	27
<b>6 MAXIMUM PEAK OUTPUT POWER MEASUREMENT</b> .....	<b>30</b>
6.1 Test Equipment.....	30
6.2 Block Diagram of Test Setup.....	30
6.3 Specification Limits (§15.247(b)(3)).....	30
6.4 Operating Condition of EUT.....	30
6.5 Test Procedure.....	30
6.6 Test Results.....	30
<b>7 EMISSION LIMITATIONS MEASUREMENT</b> .....	<b>31</b>
7.1 Test Equipment.....	31
7.2 Block Diagram of Test Setup.....	31
7.3 Specification Limits (§15.247(d)).....	31
7.4 Operating Condition of EUT.....	31
7.5 Test Procedure.....	31
7.6 Test Results.....	31
<b>8 BAND EDGES MEASUREMENT</b> .....	<b>41</b>

8.1 Test Equipment..... 41

8.2 Block Diagram of Test Setup ..... 41

8.3 Specification Limits (§15.247(d)) ..... 41

8.4 Operating Condition of EUT ..... 41

8.5 Test Procedure..... 41

8.6 Test Results ..... 41

**9 POWER SPECTRAL DENSITY MEASUREMENT ..... 43**

9.1 Test Equipment..... 43

9.2 Block Diagram of Test Setup ..... 43

9.3 Specification Limits (§15.247(e)) ..... 43

9.4 Operating Condition of EUT ..... 43

9.5 Test Procedure..... 43

9.6 Test Results ..... 43

**10 DEVIATION TO TEST SPECIFICATIONS ..... 46**

## TEST REPORT FOR FCC CERTIFICATE

Applicant : Philips (China) Investment Co., Ltd.  
 Manufacturer : Philips (China) Investment Co., Ltd.  
 Factory #1 : CHANGAN WIN CHANNEL ELECTRONICS COMPANY LIMITED  
 Factory #2 : Arts Electronics Co., Ltd.  
 EUT Description : LED LAMPS  
                   (A) Model No. : 9290002265  
                   (B) Power Supply : AC 110-130V, 50/60Hz  
                   (C) Test Voltage : AC 120V/60Hz

Test Procedure Used:

*FCC RULES AND REGULATIONS PART 15 SUBPART C OCTOBER 2012  
AND ANSI C63.4-2003*

The device described above is tested by Audix Technology (Shanghai) Co., Ltd. to determine the maximum emission levels emanating from the device. The maximum emission levels are compared to the FCC Part 15 Subpart C limits.

The test results are contained in this test report and Audix Technology (Shanghai) Co., Ltd. is assumed full responsibility for the accuracy and completeness of these measurements. This report also shows that the EUT (M/N: 9290002265), which was tested on Feb. 01 - 22, 2013 is technically compliance with the FCC limits.

This report applies to above tested sample only. This report shall not be reproduced in part without written approval of Audix Technology (Shanghai) Co., Ltd.

This report must not be used by the client to claim product certification, approval, or endorsement by NVLAP, NIST, or any agency of the federal government.

Date of Test : Feb. 01 - 22, 2013 Date of Report : Mar. 13, 2013

Producer :   
KATHY WANG / Assistant

Review :   
DIO YANG / Assistant Manager

 For and on behalf of  
Audix Technology (Shanghai) Co., Ltd.

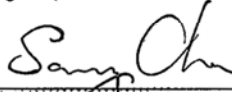
Signatory :   
Authorized Signature EMC SAMMY CHEN/ Deputy Manager

# 1 SUMMARY OF STANDARDS AND RESULTS

## 1.1 Description of Standards and Results

The EUT have been tested according to the applicable standards as referenced below:

Description / Test Item	Test Standard	Results	Meets Limit
<b>EMISSION</b>			
Conducted Emission	FCC RULES AND REGULATIONS PART 15 SUBPART C October 2012 AND ANSI C63.4:2003 AND KDB558074 v02:2012	Pass	15.207
Radiated Emission	FCC RULES AND REGULATIONS PART 15 SUBPART C October 2012 AND ANSI C63.4:2003 AND KDB558074 v02:2012	Pass	15.209(a) 15.205(a)(c)
6 dB Bandwidth Measurement	FCC RULES AND REGULATIONS PART 15 SUBPART C October 2012 AND ANSI C63.4:2003 AND KDB558074 v02:2012	Pass	15.247(a)(2)
Maximum Peak Output Power Measurement	FCC RULES AND REGULATIONS PART 15 SUBPART C October 2012 AND ANSI C63.4:2003 AND KDB558074 v02:2012	Pass	15.247(b)(3)
Emission Limitations Measurement	FCC RULES AND REGULATIONS PART 15 SUBPART C October 2012 AND ANSI C63.4:2003 AND KDB558074 v02:2012	Pass	15.247(d)
Band Edge Measurement	FCC RULES AND REGULATIONS PART 15 SUBPART C October 2012 AND ANSI C63.4:2003 AND KDB558074 v02:2012	Pass	15.247(d)
Power Spectral Density Measurement	FCC RULES AND REGULATIONS PART 15 SUBPART C October 2012 AND ANSI C63.4:2003 AND KDB558074 v02:2012	Pass	15.247(e)

## 2 GENERAL INFORMATION

### 2.1 Description of Equipment Under Test

Description	:	LED LAMPS
Type of EUT	:	<input checked="" type="checkbox"/> Production <input type="checkbox"/> Pre-product <input type="checkbox"/> Pro-type
Model Number	:	9290002265
Radio Tech	:	IEEE 802.15.4 (ZigBee®)
Freq. Band	:	2405 MHz ~ 2480 MHz Total 5 Channels: 2405 MHz, 2425 MHz, 2450 MHz, 2475 MHz, 2480 MHz
Tested Freq.	:	2405 MHz (Channel 01) 2450 MHz (Channel 03) 2480 MHz (Channel 05)
Antenna Gain	:	-10 dBi
Antenna Type	:	PCB antenna
Applicant	:	Philips (China) Investment Co., Ltd. No.9, Lane 888, Tian Lin Road, 200233, Shanghai, China
Manufacturer	:	Philips (China) Investment Co., Ltd. No.9, Lane 888, Tian Lin Road, 200233, Shanghai, China
Factory #1	:	CHANGAN WIN CHANNEL ELECTRONICS COMPANY LIMITED No.85, TONG GU XIA LU, SHANGJIAO COMMUNITY, CHANGAN TOWN, DONGGUAN CITY, GUANGDONG PROVINCE, CHINA
Factory #2	:	Arts Electronics Co., Ltd. No.1 Shang Xing Lu, Shang Jiao Community, Chang An Town, Dongguan City, Guangdong Province 523000, China.

## 2.2 Description of Test Facility

Site Description (Semi-Anechoic Chamber)	: Sept. 17, 1998 file on Apr 29, 2009 Renewed Federal Communications Commission FCC Engineering Laboratory 7435 Oakland Mills Road Columbia, MD 21046, USA
Name of Firm	: Audix Technology (Shanghai) Co., Ltd.
Site Location	: 3 F 34 Bldg 680 Guiping Rd., Caohejing Hi-Tech Park, Shanghai 200233, China
FCC registration Number	: 91789
Accredited by NVLAP, Lab Code	: 200371-0

## 2.3 Measurement Uncertainty

Conducted Emission Expanded Uncertainty	: U = 3.42 dB
Radiated Emission Expanded Uncertainty (30-200MHz):	U = 4.14dB (Horizontal) U = 4.28dB (Vertical)
Radiated Emission Expanded Uncertainty (200M-1GHz):	U = 4.18dB (Horizontal) U = 4.26dB (Vertical)
Radiated Emission Expanded Uncertainty (Above 1GHz):	U= 4.50 dB (Horizontal) U= 4.16 dB (Vertical)
6 dB Bandwidth Expanded Uncertainty	: U = 0.05 kHz
Maximum Peak Output Power Expanded Uncertainty:	U = 0.30 dB
Emission Limitations Expanded Uncertainty	: U = 0.15 dB
Band Edge Expanded Uncertainty	: U = 0.15 dB
Power Spectral Density Expanded Uncertainty	: U = 0.15 dB

### 3 CONDUCTED EMISSION TEST

#### 3.1 Test Equipment

The following test equipments are used during the conducted emission test in a shielded room:

Item	Type	Manufacturer	Model No.	Serial No.	Last Cal.	Next Cal.
1.	Test Receiver	R&S	ESCI	100841	Mar 22, 2012	Mar 22, 2013
2.	Artificial Mains Network (AMN)	R&S	ESH2-Z5	843890/011	Feb 13, 2012	Feb 13, 2013
3.	50 $\Omega$ Coaxial Switch	Anritsu	MP59B	6200426389	Sep 18, 2012	Mar 18, 2013
4.	Software	Audix	E3	SET00200 9804M592	--	--

#### 3.2 Block Diagram of Test Setup

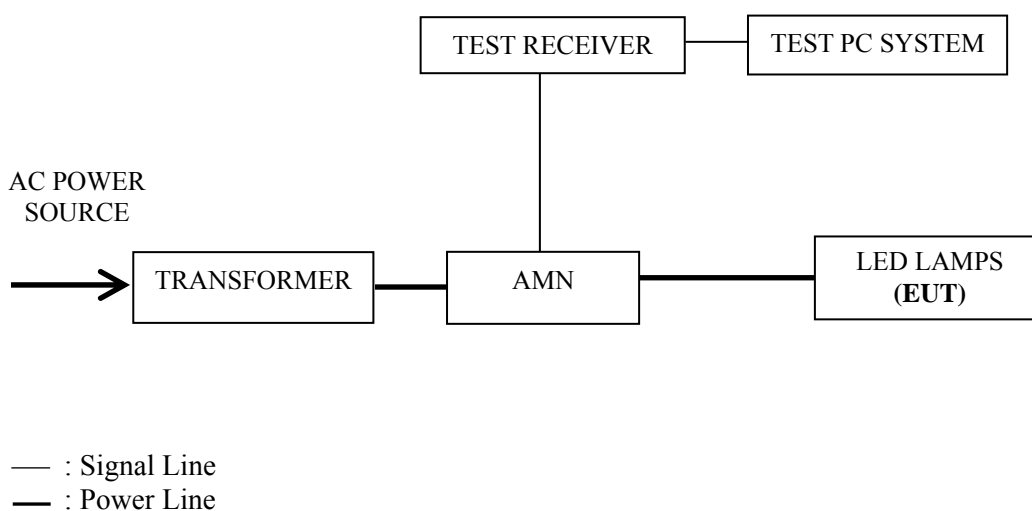

#### 3.3 Conducted Emission Limit [FCC Part 15 Subpart B 15.207]

Frequency Range (MHz)	Limits dB ( $\mu$ V)	
	Quasi-peak	Average
0.15 ~ 0.5	66~56	56~46
0.5 ~ 5	56	46
5 ~ 30	60	50

NOTE 1 – The lower limit shall apply at the transition frequencies.  
NOTE 2 – The limit decreases linearly with the logarithm of the frequency in the range 0.15 MHz~0.50 MHz



### 3.4 Test Configuration

The EUT (listed in Sec.2.1) was installed as shown on Sec.3.2 to meet FCC requirement and operating in a manner that tends to maximize its emission level in a normal application.

### 3.5 Operating Condition of EUT

3.5.1 Setup the EUT as shown in Sec. 3.2.

3.5.2 Turn on the power of all equipments and the EUT.

3.5.3 Set the EUT on the test mode (Transmitting), and then test.

### 3.6 Test Procedures

The EUT was connected to the power mains through an Artificial Mains Network (AMN). This provided a 50 ohm coupling impedance for the measuring equipment.

Both sides of AC line (Line & Neutral) were checked for maximum conducted interference. In order to find the maximum emission, the relative positions of equipment and all of the interface cables were changed or manipulated according to ANSI C63.4:2003 during conducted emission test.

The bandwidth of R&S Test Receiver ESCI was set at 9 kHz.

The frequency range from 150 kHz to 30 MHz was checked.

The test modes were done on conducted disturbance test and all the test results are listed in Sec. 3.7.

### 3.7 Test Results

< **PASS** >

The frequency and amplitude of the highest conducted emission relative to the limit is reported. All emissions not reported below are too low against the prescribed limits.

NOTE 1 – Factor = Cable Loss + AMN Factor.

NOTE 2 – Emission Level = Meter Reading + Factor.

NOTE 3 – “QP” means “Quasi-Peak” values, “AV” means “Average” values.

NOTE 4 – The worst emission is detected at 0.686 MHz (Average Value) with corrected signal level of 34.39 dB (μV) (limit is 46.00 dB (μV)), when the Line of the EUT is connected to AMN.

EUT : LED LAMPS Temperature : 22°C

Model No. : 9290002265 Humidity : 48%RH

Serial No. : -- Date of Test : Feb 01, 2013

Test Mode : Transmitting

Test Line	Frequency (MHz)	Meter Reading dB( $\mu$ V)	Factor (dB)	Emission Level dB( $\mu$ V)	Limits dB( $\mu$ V)	Margin (dB)	Remark
Line	0.204	42.89	0.25	43.14	63.45	20.31	QP
	0.273	39.20	0.25	39.45	61.03	21.58	
	0.476	38.21	0.35	38.56	56.41	17.85	
	0.686	44.19	0.19	44.38	56.00	11.62	
	2.201	34.43	0.39	34.82	56.00	21.18	
	4.672	35.63	0.50	36.13	56.00	19.87	
	AV	0.204	32.69	0.25	32.94	53.45	20.51
		0.273	29.69	0.25	29.94	51.03	21.09
		0.476	28.20	0.35	28.55	46.41	17.86
		<b>0.686</b>	<b>34.20</b>	<b>0.19</b>	<b>34.39</b>	<b>46.00</b>	<b>11.61</b>
		2.201	24.50	0.39	24.89	46.00	21.11
		4.672	25.90	0.50	26.40	46.00	19.60
Neutral	0.184	46.54	0.12	46.66	64.28	17.62	QP
	0.471	36.76	0.17	36.93	56.49	19.56	
	0.686	42.81	0.20	43.01	56.00	12.99	
	1.324	35.31	0.21	35.52	56.00	20.48	
	2.527	37.00	0.20	37.20	56.00	18.80	
	5.221	34.78	0.42	35.20	60.00	24.80	
	AV	0.184	36.58	0.12	36.70	54.28	17.58
		0.471	26.70	0.17	26.87	46.49	19.62
		0.686	32.69	0.20	32.89	46.00	13.11
		1.324	25.98	0.21	26.19	46.00	19.81
		2.527	27.10	0.20	27.30	46.00	18.70
		5.221	24.51	0.42	24.93	50.00	25.07

TEST ENGINEER: JOE YE

## 4 RADIATED EMISSION TEST

### 4.1 Test Equipment

The following test equipment are used during the radiated emission test in a semi-anechoic chamber:

Item	Type	Manufacturer	Model No.	Serial No.	Last Cal.	Next Cal.
1.	Preamplifier	Agilent	8447D	2944A10548	Sep 18, 2012	Mar 18, 2013
2.	Preamplifier	HP	8449B	3008A00864	Mar 22, 2012	Mar 22, 2013
3.	Spectrum Analyzer	Agilent	E7405A	MY45106600	Mar 22, 2012	Mar 22, 2013
4.	Test Receiver	R&S	ESVS10	844594/001	Mar 22, 2012	Mar 22, 2013
5.	Bi-log Antenna	TESEQ	CBL6112D	23193	May 03, 2012	May 03, 2013
6.	Horn Antenna	EMCO	3115	9607-4878	May 03, 2012	May 03, 2013
7.	Horn Antenna	EMCO	3116	00062643	Jul 21, 2012	Jul 21, 2013
8.	50Ω Coaxial Switch	Anritsu	MP59B	6200426390	Sep 18, 2012	Mar 18, 2013
9.	Software	Audix	E3	SET00200 9912M295-2	-	-

### 4.2 Block Diagram of Test Setup

#### 4.2.1 Test Setup

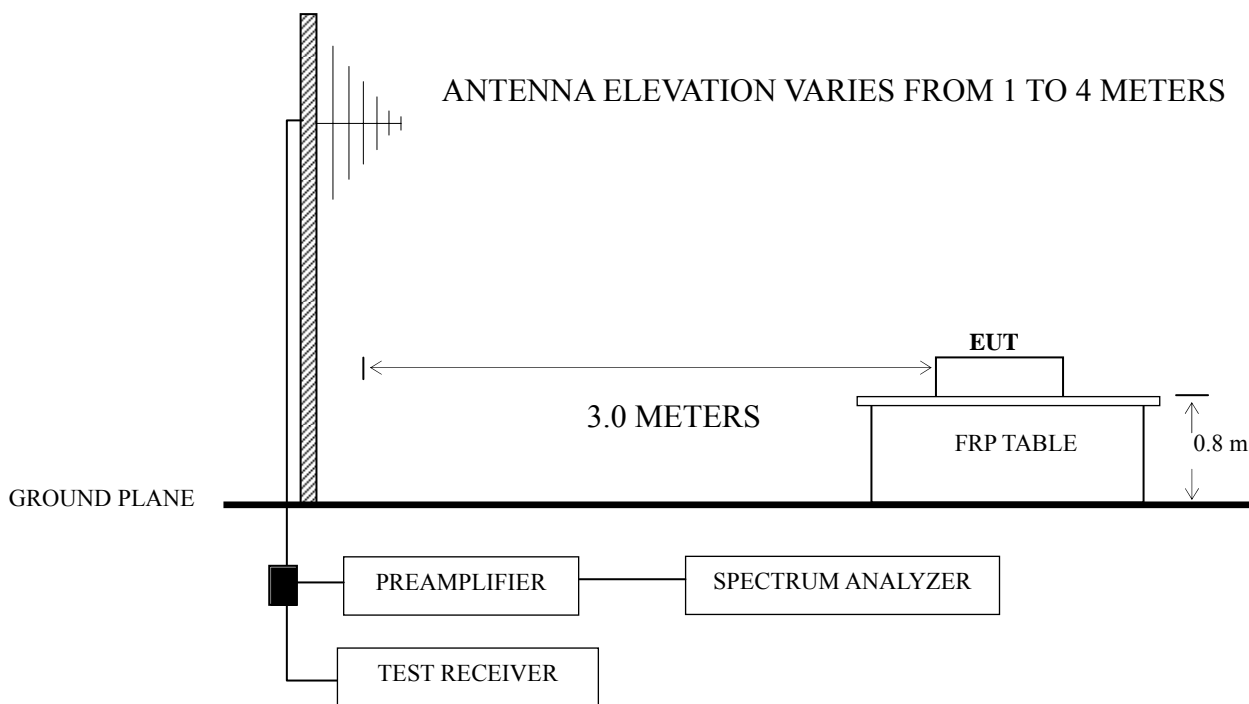

■ : 50 ohm Coaxial Switch

### 4.3 Radiated Emission Limit [FCC Part 15 Subpart C 15.209]

Frequency (MHz)	Distance (m)	Field strength limits ( $\mu\text{V/m}$ )	
		( $\mu\text{V/m}$ )	dB( $\mu\text{V/m}$ )
30 ~ 88	3	100	40.0
88 ~ 216	3	150	43.5
216 ~ 960	3	200	46.0
Above 960	3	500	54.0

NOTE 1 - Emission Level dB ( $\mu\text{V/m}$ ) = 20 log Emission Level ( $\mu\text{V/m}$ )  
NOTE 2 - The tighter limit applies at the band edges.  
NOTE 3 - Distance refers to the distance in meters between the measuring instrument antenna and the closed point of any part of the device or system.  
NOTE 4 - The limits shown are based on Quasi-peak value detector below or equal to 1GHz and Average value detector above 1GHz.  
NOTE 5 - Above 1 GHz, the limit on peak emission is 20 dB above the maximum permitted average emission limit applicable to the EUT

### 4.4 Test Configuration

The EUT (listed in Sec.2.1) and the simulators (listed in Sec.2.2) were installed as shown on Sec.3.2 to meet FCC requirements and operating in a manner that tends to maximize its emission level in a normal application.

### 4.5 Operating Condition of EUT

4.5.1 Setup the EUT as shown in Sec. 3.2.

4.5.2 Turn on the power of all equipment.

4.5.3 Turn the EUT on the test mode, and then test.

### 4.6 Test Procedures

Radiated emission test applies to harmonics/spurs that fall in the restricted bands listed in Section 15.205. The maximum permitted average field strength is listed in Section 15.209. A pre-amp is necessary for this measurement. For measurement above 1 GHz, set RBW = 1MHz, VBW = 10 Hz, Sweep: Auto. If the emission is pulsed, modify the unit for continuous operation; use the settings shown above, then correct the reading by subtracting the peak-average correction factor, derived from the appropriate duty cycle calculation.

The EUT was placed on a turntable that is 0.8 meter above ground. The turntable rotated 360 degrees to determine the position of the maximum emission level. The EUT was set 3 meters away from the receiving antenna, which was mounted on an antenna tower. The antenna moved up and down between 1 meter and 4 meters to find out the maximum emission level. Broadband antenna (Calibrated Bilog Antenna) or Horn antenna was used as receiving antenna. Both horizontal and vertical polarizations of the antenna were set on measurement. In order to find the maximum emission, all of the interference cables were manipulated according to ANSI C63.4:2003 requirements during radiated emission test.

The bandwidth of Test Receiver R&S ESVS10 was set at 120 kHz from 30MHz to 1000MHz.

The bandwidth of the VBW was set at 1MHz and RBW was set at 1MHz for peak emission measurement above 1GHz for Spectrum Agilent E7405A.

The frequency range from 30 MHz to 25 GHz (Up to 10<sup>th</sup> harmonics from fundamental frequency) was checked.

The EUT was tested under the following test modes:

Mode	Operation	Channel	Frequency
1.	Transmitting	01	2405 MHz
2.		03	2450 MHz
3.		05	2480 MHz
4.	Receiving	--	--
5.	Transmitting	01	2405 MHz
6.	Band-Edge	05	2480 MHz

All the test results are listed in Sec.4.7.

## 4.7 Test Results

<PASS>

The frequency and amplitude of the highest radiated emission relative the limit is reported. All the emissions not reported below are too low against the FCC limit.

No.	Operation	Channel	Frequency	Data Page	
1.	Transmitting	01	2405 MHz	P15	
2.		03	2450 MHz	P16	
3.		05	2480 MHz	P17	
7.	Receiving	--	--	P18	
10.	Transmitting	01	2405 MHz	Band	P19-P20
11.		05	2480 MHz	Edge	P21-P22

NOTE 1 – Level = Read Level + Antenna Factor + Cable Loss (<1GHz)

NOTE 2 – Level = Read Level + Antenna Factor + Cable Loss - Preamp Factor (>1GHz)

NOTE 3 – All reading are Quasi-Peak values below or equal to 1GHz, Peak and Average values above 1GHz.

For above 1GHz test, if the peak measured value complies with the average limit, it is unnecessary to perform an average measurement.

EUT : LED LAMPS Temperature : 23°C

Model No. : 9290002265 Humidity : 41%RH

Serial No. : -- Date of Test : Feb 22, 2013

Test Mode : Transmitting Ch01

Polarization	Frequency (MHz)	Meter Reading dB (μV)	Antenna Factor (dB/m)	Cable Loss (dB)	Preamp Factor (dB)	Emission Level dB (μV/m)	Limits dB (μV/m)	Margin (dB)	Remark
Horizontal	106.63	12.20	11.50	1.39	--	25.09	43.50	18.41	QP
	<b>189.08</b>	<b>24.17</b>	<b>8.00</b>	<b>1.89</b>	--	<b>34.06</b>	<b>43.50</b>	<b>9.44</b>	
	196.84	24.47	8.20	1.94	--	34.61	43.50	8.89	
	313.24	19.01	13.52	2.57	--	35.10	46.00	10.90	
	385.99	16.80	15.30	2.67	--	34.77	46.00	11.23	
	856.44	5.61	20.80	4.08	--	30.49	46.00	15.51	
	1918.00	44.16	30.30	6.18	36.19	44.45	74.00	29.55	PK
	3817.00	44.09	32.05	8.38	35.43	49.09	74.00	24.91	
	5644.00	43.84	33.24	8.75	34.70	51.13	74.00	22.87	
Vertical	36.79	15.90	14.92	0.74	--	31.56	40.00	8.44	QP
	106.63	23.86	11.50	1.39	--	36.75	43.50	6.75	
	<b>138.64</b>	<b>24.87</b>	<b>10.51</b>	<b>1.59</b>	--	<b>36.97</b>	<b>43.50</b>	<b>6.53</b>	
	187.14	24.53	8.10	1.87	--	34.50	43.50	9.00	
	318.09	20.49	13.75	2.58	--	36.82	46.00	9.18	
	426.73	14.97	17.47	2.76	--	35.20	46.00	10.80	
	2026.00	44.18	30.88	6.20	36.09	45.17	74.00	28.83	PK
	3754.00	44.48	31.84	8.35	35.45	49.22	74.00	24.78	
	5554.00	43.81	33.41	8.68	34.73	51.17	74.00	22.83	

TEST ENGINEER: RAVEN JIN

EUT : LED LAMPS Temperature : 23°C

Model No. : 9290002265 Humidity : 41%RH

Serial No. : -- Date of Test : Feb 22, 2013

Test Mode : Transmitting Ch03

Polarization	Frequency (MHz)	Meter Reading dB (μV)	Antenna Factor (dB/m)	Cable Loss (dB)	Preamp Factor (dB)	Emission Level dB (μV/m)	Limits dB (μV/m)	Margin (dB)	Remark
Horizontal	104.69	18.70	11.30	1.37	--	31.37	43.50	12.13	QP
	145.43	13.71	10.28	1.62	--	25.61	43.50	17.89	
	<b>193.93</b>	<b>26.13</b>	<b>8.10</b>	<b>1.92</b>	--	<b>36.15</b>	<b>43.50</b>	<b>7.35</b>	
	237.58	17.20	10.67	2.15	--	30.02	46.00	15.98	
	329.73	13.91	14.40	2.59	--	30.90	46.00	15.10	
	415.09	14.28	16.75	2.73	--	33.76	46.00	12.24	
	1999.00	44.44	31.00	6.20	36.10	45.54	74.00	28.46	PK
	3646.00	44.77	31.40	8.29	35.47	48.99	74.00	25.01	
	5437.00	43.60	33.04	8.71	34.77	50.58	74.00	23.42	
Vertical	33.88	13.55	16.12	0.70	--	30.37	40.00	9.63	QP
	104.69	24.29	11.30	1.37	--	36.96	43.50	6.54	
	130.88	23.18	11.72	1.55	--	36.45	43.50	7.05	
	<b>189.08</b>	<b>28.33</b>	<b>8.00</b>	<b>1.89</b>	--	<b>38.22</b>	<b>43.50</b>	<b>5.28</b>	
	269.59	19.67	12.60	2.32	--	34.59	46.00	11.41	
	313.24	17.86	13.52	2.57	--	33.95	46.00	12.05	
	1954.00	44.14	30.64	6.19	36.15	44.82	74.00	29.18	PK
	3700.00	44.37	31.61	8.32	35.46	48.84	74.00	25.16	
	5464.00	44.12	33.27	8.61	34.76	51.24	74.00	22.76	

TEST ENGINEER: RAVEN JIN



EUT : LED LAMPS Temperature : 23°C

Model No. : 9290002265 Humidity : 41%RH

Serial No. : -- Date of Test : Feb 22, 2013

Test Mode : Transmitting Ch05

Polarization	Frequency (MHz)	Meter Reading dB (μV)	Antenna Factor (dB/m)	Cable Loss (dB)	Preamp Factor (dB)	Emission Level dB (μV/m)	Limits dB (μV/m)	Margin (dB)	Remark
Horizontal	104.69	15.44	11.30	1.37	--	28.11	43.50	15.39	QP
	<b>193.93</b>	<b>25.34</b>	<b>8.10</b>	<b>1.92</b>	--	<b>35.36</b>	<b>43.50</b>	<b>8.14</b>	
	308.39	19.23	13.20	2.56	--	34.99	46.00	11.01	
	381.14	13.34	15.20	2.66	--	31.20	46.00	14.80	
	429.64	9.51	17.60	2.78	--	29.89	46.00	16.11	
	853.53	4.72	20.90	4.08	--	29.70	46.00	16.30	
	2044.00	45.11	30.78	6.22	36.09	46.02	74.00	27.98	PK
	3529.00	45.30	30.91	8.24	35.50	48.95	74.00	25.05	
Vertical	5473.00	43.83	33.27	8.61	34.76	50.95	74.00	23.05	PK
	36.79	14.81	14.92	0.74	--	30.47	40.00	9.53	
	<b>105.70</b>	<b>23.86</b>	<b>11.40</b>	<b>1.38</b>	--	<b>36.64</b>	<b>43.50</b>	<b>6.86</b>	
	128.94	22.49	11.82	1.53	--	35.84	43.50	7.66	
	182.29	22.16	8.25	1.84	--	32.25	43.50	11.25	
	315.18	19.78	13.60	2.57	--	35.95	46.00	10.05	
	385.99	14.03	15.30	2.67	--	32.00	46.00	14.00	
	1765.00	46.02	28.75	6.11	36.40	44.48	74.00	29.52	
3646.00	44.90	31.40	8.29	35.47	49.12	74.00	24.88		
5680.00	43.95	33.18	8.82	34.69	51.26	74.00	22.74		

TEST ENGINEER: RAVEN JIN

EUT : LED LAMPS Temperature : 23°C

Model No. : 9290002265 Humidity : 41%RH

Serial No. : -- Date of Test : Feb 22, 2013

Test Mode : Receiving

Polarization	Frequency (MHz)	Meter Reading dB (μV)	Antenna Factor (dB/m)	Cable Loss (dB)	Preamp Factor (dB)	Emission Level dB (μV/m)	Limits dB (μV/m)	Margin (dB)	Remark
Horizontal	104.69	13.22	11.30	1.37	--	25.89	43.50	17.61	QP
	128.94	10.19	11.82	1.53	--	23.54	43.50	19.96	
	<b>196.84</b>	<b>24.24</b>	<b>8.20</b>	<b>1.94</b>	--	<b>34.38</b>	<b>43.50</b>	<b>9.12</b>	
	329.73	15.17	14.40	2.59	--	32.16	46.00	13.84	
	385.99	12.32	15.30	2.67	--	30.29	46.00	15.71	
	424.79	8.76	17.40	2.76	--	28.92	46.00	17.08	
	1990.00	44.70	30.91	6.19	36.11	45.69	74.00	28.31	PK
	4123.00	43.81	32.27	8.56	35.35	49.29	74.00	24.71	
Vertical	5590.00	43.91	33.36	8.68	34.72	51.23	74.00	22.77	QP
	36.79	15.05	14.92	0.74	--	30.71	40.00	9.29	
	104.69	23.18	11.30	1.37	--	35.85	43.50	7.65	
	<b>128.94</b>	<b>23.71</b>	<b>11.82</b>	<b>1.53</b>	--	<b>37.06</b>	<b>43.50</b>	<b>6.44</b>	
	184.23	23.82	8.28	1.86	--	33.96	43.50	9.54	
	320.03	20.14	13.90	2.58	--	36.62	46.00	9.38	
	390.84	13.64	15.40	2.68	--	31.72	46.00	14.28	
	1999.00	43.87	31.00	6.20	36.10	44.97	74.00	29.03	
3799.00	44.72	32.01	8.38	35.44	49.67	74.00	24.33		
5662.00	44.17	33.21	8.75	34.70	51.43	74.00	22.57		

TEST ENGINEER: RAVEN JIN

### Band edge using radiated measurement:



Audix Technology (Shanghai) Co., Ltd.  
 3F #34Bldg. No.680 GuiPing Rd.,  
 CaoHeJing Hi-Tech Park,  
 Shanghai 200233, China  
 Tel:+86-21-64955500 Fax:+86-21-64955491  
 audixaci@audix.com

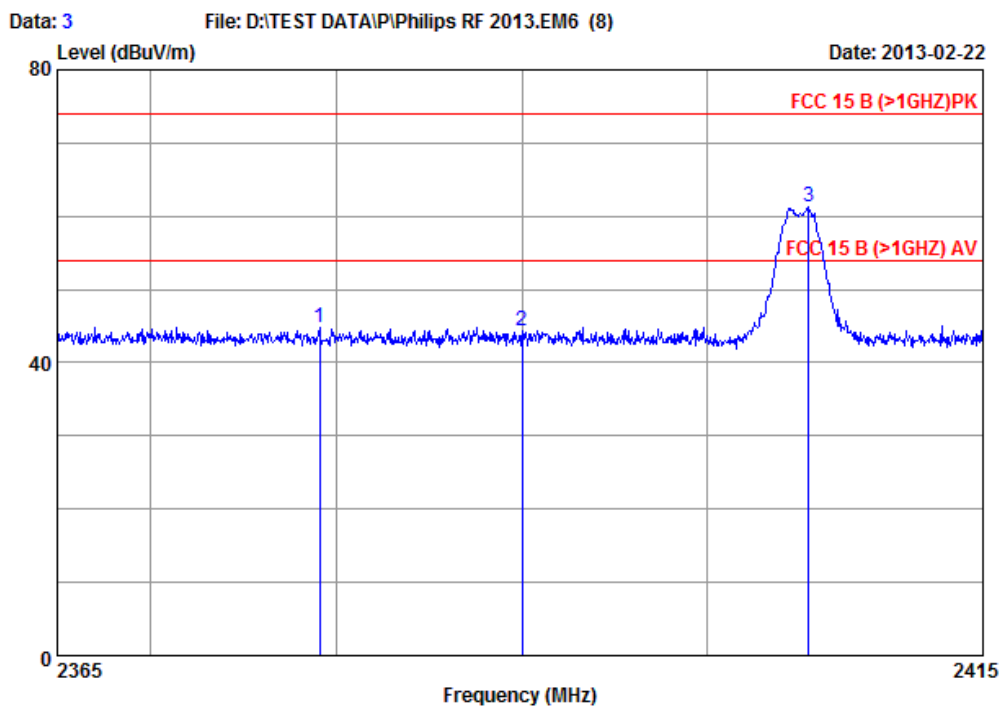

Site no : Audix ACI (3m Chamber) Data no. : 3  
 Dis. / Ant. : 3m /EMCO 3115  
 Limit : FCC 15 B (>1GHZ)PK Ant. pol. : HORIZONTAL  
 Env. / Ins. : 22'C 60%RH/ E7405A Engineer : Dio  
 EUT : LED LAMPS  
 M/N : 9290002265  
 Power Rating: 120V/60Hz  
 Test Mode : TX CH1 2405MHz

	Freq. (MHz)	Antenna Factor (dB/m)	Preamp Factor (dB)	Cable Loss (dB)	Reading (dBuV)	Emission Level (dBuV/m)	Limits (dBuV/m)	Margin (dB)	Remark
1	2379.050	28.83	35.96	6.42	45.56	44.85	74.00	29.15	Peak
2	2390.000	28.80	35.95	6.42	45.09	44.36	74.00	29.64	Peak
3	2405.500	28.70	35.95	6.42	62.19	61.36	74.00	12.64	Peak

Remarks: Emission Level= Antenna Factor + Cable Loss - Preamp Factor + Reading.



Audix Technology (Shanghai) Co., Ltd.  
 3F #34Bldg. No.680 GuiPing Rd.,  
 CaoHeJing Hi-Tech Park,  
 Shanghai 200233, China  
 Tel:+86-21-64955500 Fax:+86-21-64955491  
 audixaci@audix.com

Data: 4 File: D:\TEST DATA\PI\Philips RF 2013.EM6 (8) Date: 2013-02-22 Time: 10:20:43

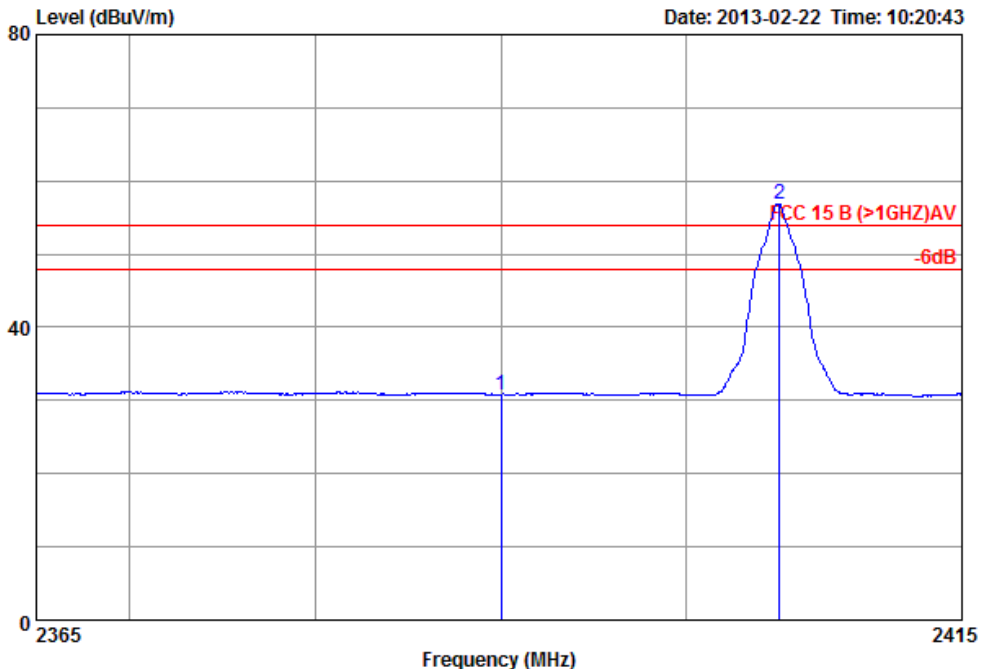

Site no : Audix ACI (3m Chamber) Data no. : 4  
 Dis. / Ant. : 3m /EMCO3115 2012-05-03  
 Limit : FCC 15 B (>1GHZ)AV Ant. pol. : HORIZONTAL  
 Env. / Ins. : 22'C 60%RH/ E7405A Engineer : Dio  
 EUT : LED LAMPS  
 M/N : 9290002265  
 Power Rating: 120V/60Hz  
 Test Mode : TX CH1 2405MHz

	Freq. (MHz)	Antenna Factor (dB/m)	Preamp Factor (dB)	Cable Loss (dB)	Reading (dBuV)	Emission Level (dBuV/m)	Limits (dBuV/m)	Margin (dB)	Remark
1	2390.000	28.80	35.95	6.42	31.56	30.83	54.00	23.17	Average
2	2405.050	28.70	35.95	6.42	57.73	56.90	54.00	-2.90	Average

Remarks: Emission Level= Antenna Factor + Cable Loss - Preamp Factor + Reading.



Audix Technology (Shanghai) Co., Ltd.  
 3F #34Bldg. No.680 GuiPing Rd.,  
 CaoHeJing Hi-Tech Park,  
 Shanghai 200233, China  
 Tel:+86-21-64955500 Fax:+86-21-64955491  
 audixaci@audix.com

Data: 1 File: D:\TEST DATA\PI\Philips RF 2013.EM6 (8) Date: 2013-02-22

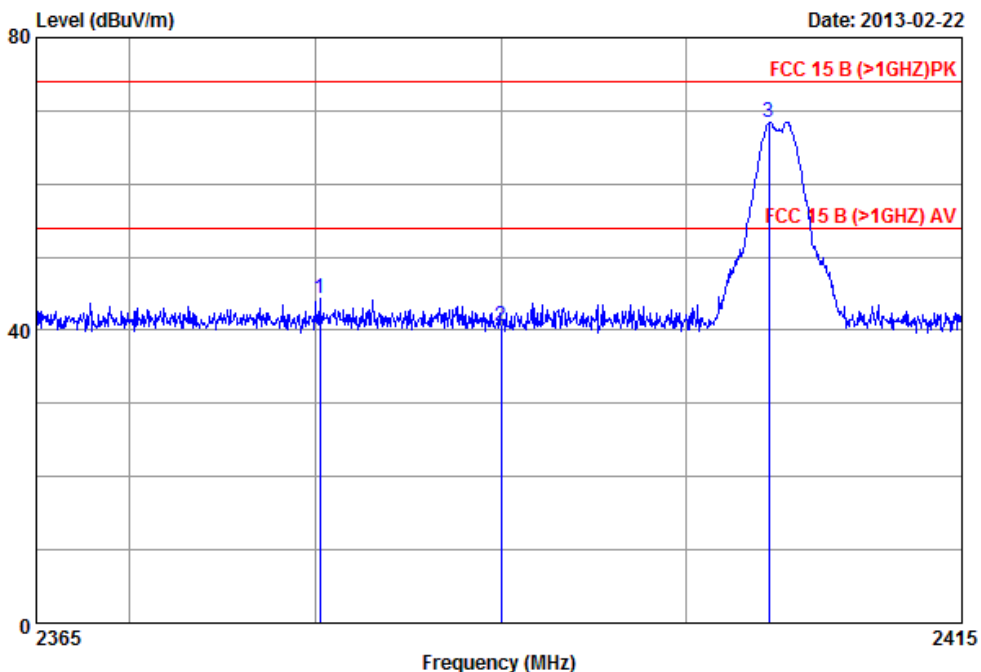

Site no : Audix ACI (3m Chamber) Data no. : 1  
 Dis. / Ant. : 3m /EMCO 3115  
 Limit : FCC 15 B (>1GHZ)PK Ant. pol. : VERTICAL  
 Env. / Ins. : 22'C 60%RH/ E7405A Engineer : Dio  
 EUT : LED LAMPS  
 M/N : 9290002265  
 Power Rating: 120V/60Hz  
 Test Mode : TX CH1 2405MHz

	Freq. (MHz)	Antenna Factor (dB/m)	Preamp Factor (dB)	Cable Loss (dB)	Reading (dBuV)	Emission Level (dBuV/m)	Limits (dBuV/m)	Margin (dB)	Remark
1	2380.200	28.83	35.96	6.42	44.95	44.24	74.00	29.76	Peak
2	2390.000	28.80	35.95	6.42	41.29	40.56	74.00	33.44	Peak
3	2404.500	28.70	35.95	6.42	69.34	68.51	74.00	5.49	Peak

Remarks: Emission Level= Antenna Factor + Cable Loss - Preamp Factor + Reading.



Audix Technology (Shanghai) Co., Ltd.  
 3F #34Bldg. No.680 GuiPing Rd.,  
 CaoHeJing Hi-Tech Park,  
 Shanghai 200233, China  
 Tel:+86-21-64955500 Fax:+86-21-64955491  
 audixaci@audix.com

Data: 2 File: D:\TEST DATA\PI\Philips RF 2013.EM6 (8) Date: 2013-02-22 Time: 10:16:50

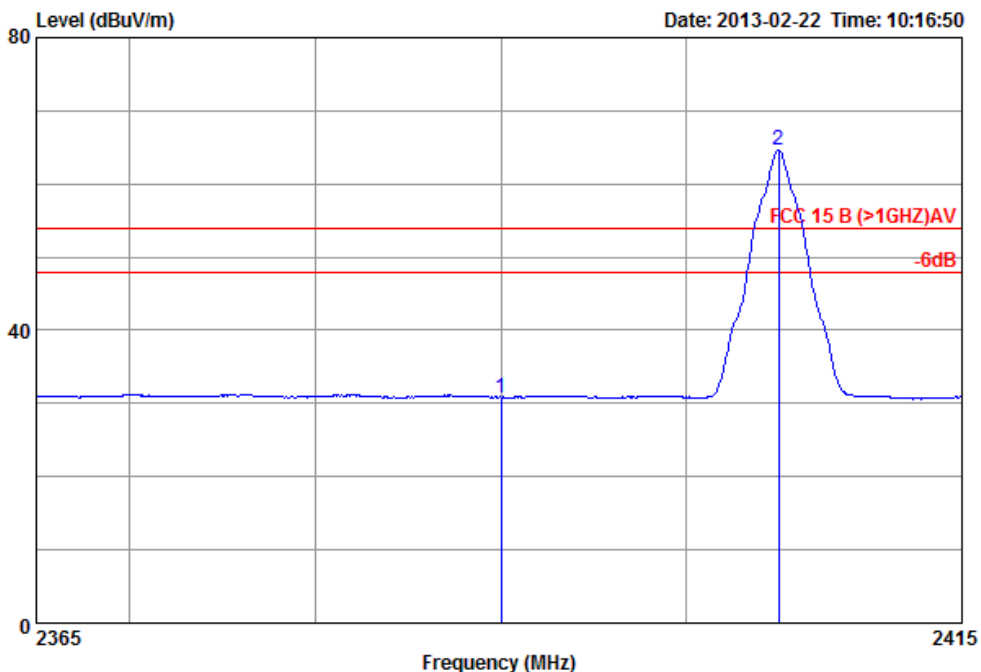

Site no : Audix ACI (3m Chamber) Data no. : 2  
 Dis. / Ant. : 3m /EMCO3115 2012-05-03  
 Limit : FCC 15 B (>1GHZ)AV Ant. pol. : VERTICAL  
 Env. / Ins. : 22'C 60%RH/ E7405A Engineer : Dio  
 EUT : LED LAMPS  
 M/N : 9290002265  
 Power Rating: 120V/60Hz  
 Test Mode : TX CH1 2405MHz

	Freq. (MHz)	Antenna Factor (dB/m)	Preamp Factor (dB)	Cable Loss (dB)	Reading (dBuV)	Emission Level (dBuV/m)	Limits (dBuV/m)	Margin (dB)	Remark
1	2390.000	28.80	35.95	6.42	31.59	30.86	54.00	23.14	Average
2	2405.000	28.70	35.95	6.42	65.48	64.65	54.00	-10.65	Average

Remarks: Emission Level= Antenna Factor + Cable Loss - Preamp Factor + Reading.



Audix Technology (Shanghai) Co., Ltd.  
 3F #34Bldg. No.680 GuiPing Rd.,  
 CaoHeJing Hi-Tech Park,  
 Shanghai 200233, China  
 Tel:+86-21-64955500 Fax:+86-21-64955491  
 audixaci@audix.com

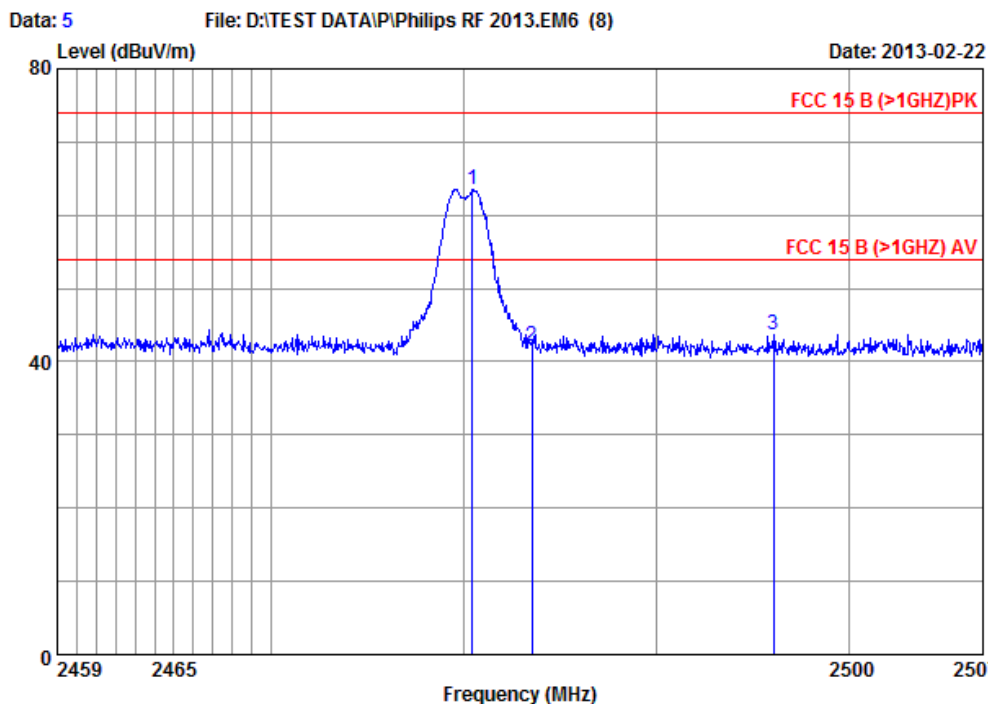

Site no : Audix ACI (3m Chamber) Data no. : 5  
 Dis. / Ant. : 3m /EMCO 3115  
 Limit : FCC 15 B (>1GHZ)PK Ant. pol. : HORIZONTAL  
 Env. / Ins. : 22'C 60%RH/ E7405A Engineer : Dio  
 EUT : LED LAMPS  
 M/N : 9290002265  
 Power Rating: 120V/60Hz  
 Test Mode : TX CH5 2480MHz

	Freq. (MHz)	Antenna Factor (dB/m)	Preamp Factor (dB)	Cable Loss (dB)	Reading (dBuV)	Emission Level (dBuV/m)	Limits (dBuV/m)	Margin (dB)	Remark
1	2480.408	28.39	35.91	6.45	64.61	63.54	74.00	10.46	Peak
2	2483.500	28.36	35.91	6.45	43.31	42.21	74.00	31.79	Peak
3	2496.056	28.33	35.91	6.47	44.73	43.62	74.00	30.38	Peak

Remarks: Emission Level= Antenna Factor + Cable Loss - Preamp Factor + Reading.



Audix Technology (Shanghai) Co., Ltd.  
 3F #34Bldg. No.680 GuiPing Rd.,  
 CaoHeJing Hi-Tech Park,  
 Shanghai 200233, China  
 Tel:+86-21-64955500 Fax:+86-21-64955491  
 audixaci@audix.com

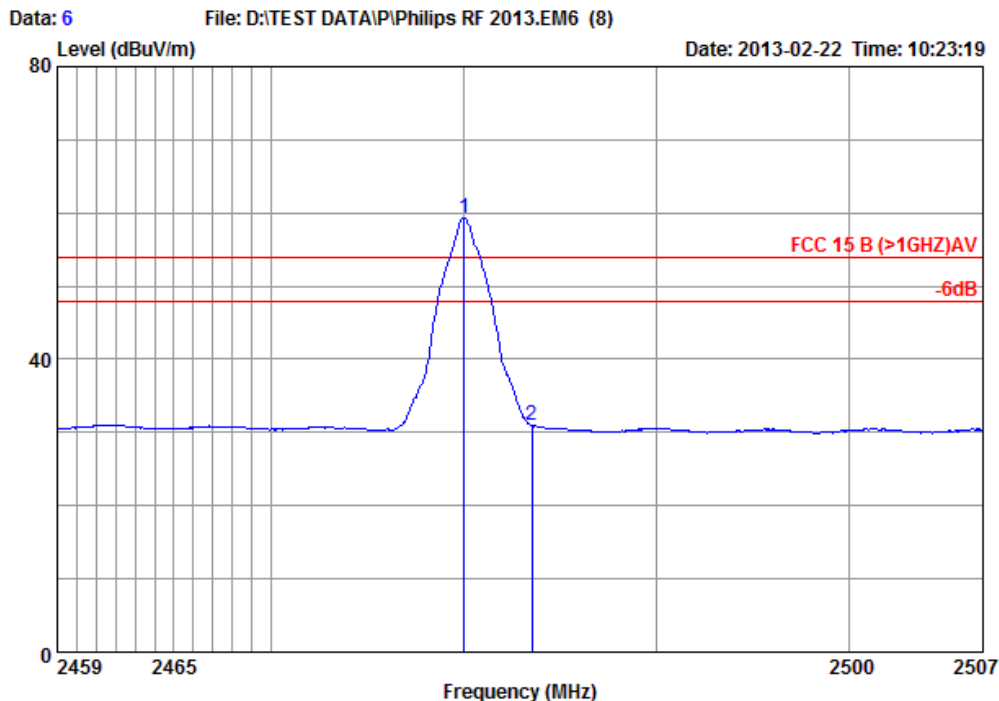

Site no : Audix ACI (3m Chamber) Data no. : 6  
 Dis. / Ant. : 3m /EMCO3115 2012-05-03  
 Limit : FCC 15 B (>1GHZ)AV Ant. pol. : HORIZONTAL  
 Env. / Ins. : 22'C 60%RH/ E7405A Engineer : Dio  
 EUT : LED LAMPS  
 M/N : 9290002265  
 Power Rating: 120V/60Hz  
 Test Mode : TX CH5 2480MHz

	Freq. (MHz)	Antenna Factor (dB/m)	Preamp Factor (dB)	Cable Loss (dB)	Reading (dBuV)	Emission Level (dBuV/m)	Limits (dBuV/m)	Margin (dB)	Remark
1	2479.976	28.39	35.91	6.45	60.43	59.36	54.00	-5.36	Average
2	2483.500	28.36	35.91	6.45	32.09	30.99	54.00	23.01	Average

Remarks: Emission Level= Antenna Factor + Cable Loss - Preamp Factor + Reading.





Audix Technology (Shanghai) Co., Ltd.  
 3F #34Bldg. No.680 GuiPing Rd.,  
 CaoHeJing Hi-Tech Park,  
 Shanghai 200233, China  
 Tel:+86-21-64955500 Fax:+86-21-64955491  
 audixaci@audix.com

Data: 7 File: D:\TEST DATA\PI\Philips RF 2013.EM6 (8) Date: 2013-02-22

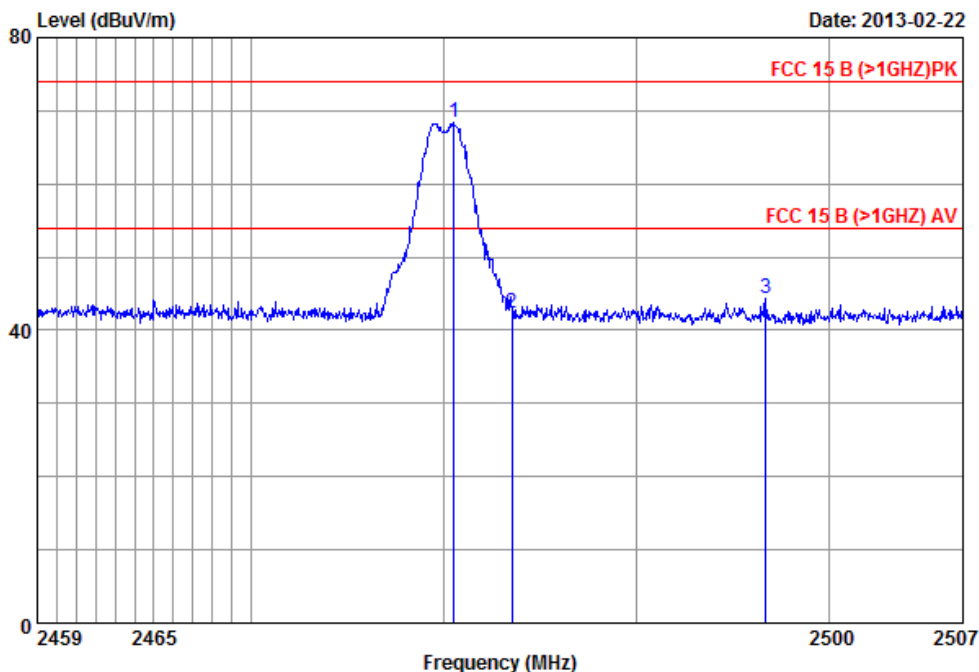

Site no : Audix ACI (3m Chamber) Data no. : 7  
 Dis. / Ant. : 3m /EMCO 3115  
 Limit : FCC 15 B (>1GHZ)PK Ant. pol. : VERTICAL  
 Env. / Ins. : 22'C 60%RH/ E7405A Engineer : Dio  
 EUT : LED LAMPS  
 M/N : 9290002265  
 Power Rating: 120V/60Hz  
 Test Mode : TX CH5 2480MHz

	Freq. (MHz)	Antenna Factor (dB/m)	Preamp Factor (dB)	Cable Loss (dB)	Reading (dBuV)	Emission Level (dBuV/m)	Limits (dBuV/m)	Margin (dB)	Remark
1	2480.504	28.39	35.91	6.45	69.48	68.41	74.00	5.59	Peak
2	2483.500	28.36	35.91	6.45	43.34	42.24	74.00	31.76	Peak
3	2496.680	28.30	35.91	6.47	45.58	44.44	74.00	29.56	Peak

Remarks: Emission Level= Antenna Factor + Cable Loss - Preamp Factor + Reading.



Audix Technology (Shanghai) Co., Ltd.  
 3F #34Bldg. No.680 GuiPing Rd.,  
 CaoHeJing Hi-Tech Park,  
 Shanghai 200233, China  
 Tel:+86-21-64955500 Fax:+86-21-64955491  
 audixaci@audix.com

Data: 8 File: D:\TEST DATA\PI\Philips RF 2013.EM6 (8) Date: 2013-02-22 Time: 10:26:45

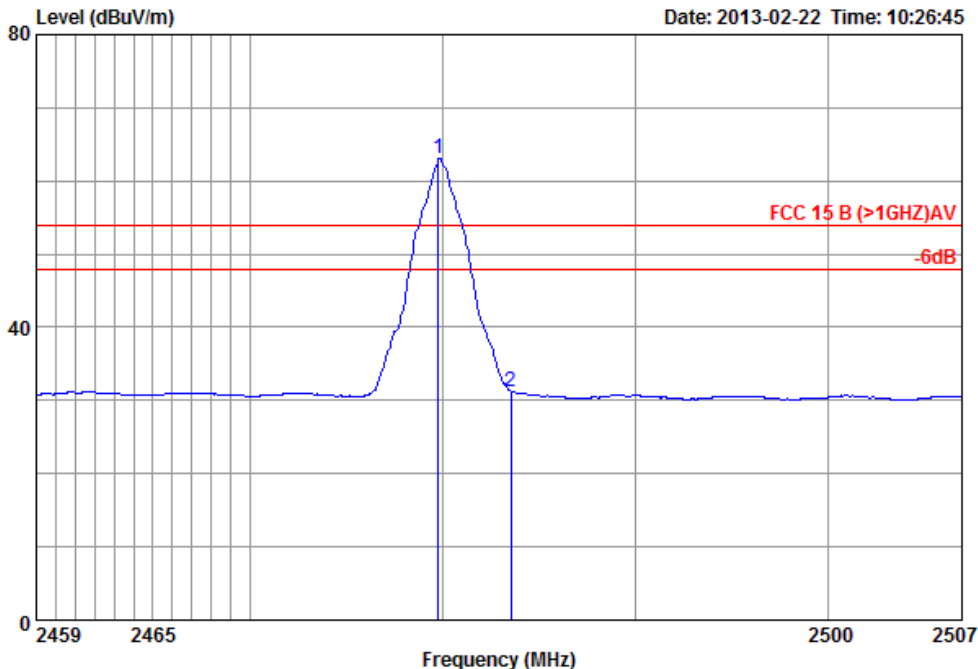

Site no : Audix ACI (3m Chamber) Data no. : 8  
 Dis. / Ant. : 3m /EMCO3115 2012-05-03  
 Limit : FCC 15 B (>1GHZ)AV Ant. pol. : VERTICAL  
 Env. / Ins. : 22'C 60%RH/ E7405A Engineer : Dio  
 EUT : LED LAMPS  
 M/N : 9290002265  
 Power Rating: 120V/60Hz  
 Test Mode : TX CH5 2480MHz

	Freq. (MHz)	Antenna Factor (dB/m)	Preamp Factor (dB)	Cable Loss (dB)	Reading (dBuV)	Emission Level (dBuV/m)	Limits (dBuV/m)	Margin (dB)	Remark
1	2479.718	28.39	35.91	6.45	64.03	62.96	54.00	-8.96	Average
2	2483.500	28.36	35.91	6.45	32.39	31.29	54.00	22.71	Average

Remarks: Emission Level= Antenna Factor + Cable Loss - Preamp Factor + Reading.

## 5 6 dB BANDWIDTH MEASUREMENT

### 5.1 Test Equipment

The following test equipment was used during the Emission Bandwidth measurement:

Item	Type	Manufacturer	Model No.	Serial No.	Last Cal.	Next Cal.
1.	Test Receiver	R&S	ESCI	101303	Sep 11, 2012	Sep 11, 2013

### 5.2 Block Diagram of Test Setup

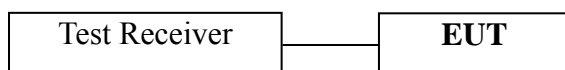

### 5.3 Specification Limits (§15.247(a)(2))

The minimum 6 dB bandwidth shall be at least 500 kHz.

### 5.4 Operating Condition of EUT

Enable the EUT to transmit data at different channel frequency individually.

### 5.5 Test Procedure

The transmitter output was connected to the test receiver / spectrum analyzer. The bandwidth of the fundamental frequency was measure by spectrum analyzer.

The 6 dB bandwidth is defined as the total spectrum the power of which is higher than peak power minus 6 dB.

The test procedure is defined in KDB558074 v01:2012 (the 5.1.1 EBW Measurement Procedure was used). The RBW/EBW ratio should be 1-5%.

### 5.6 Test Results

**PASSED.**

All the test results are attached in next pages.

(Test Date: Feb. 21, 2013 Temperature: 25°C Humidity: 48 %)

Channel	Frequency	6dB Bandwidth (EBW)
01	2405 MHz	<b>1.57 MHz</b>
03	2450 MHz	<b>1.71 MHz</b>
05	2480 MHz	<b>1.57 MHz</b>

### Ch 01 (2405 MHz)

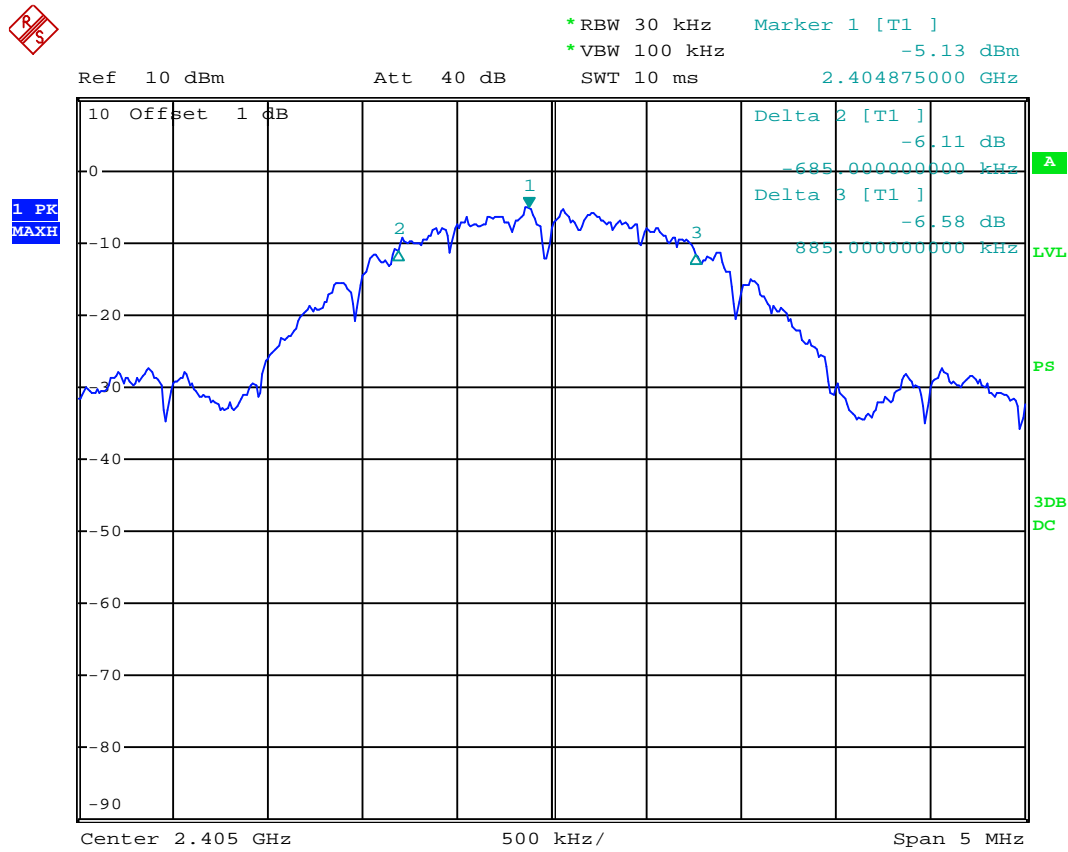

### Ch 03 (2450 MHz)

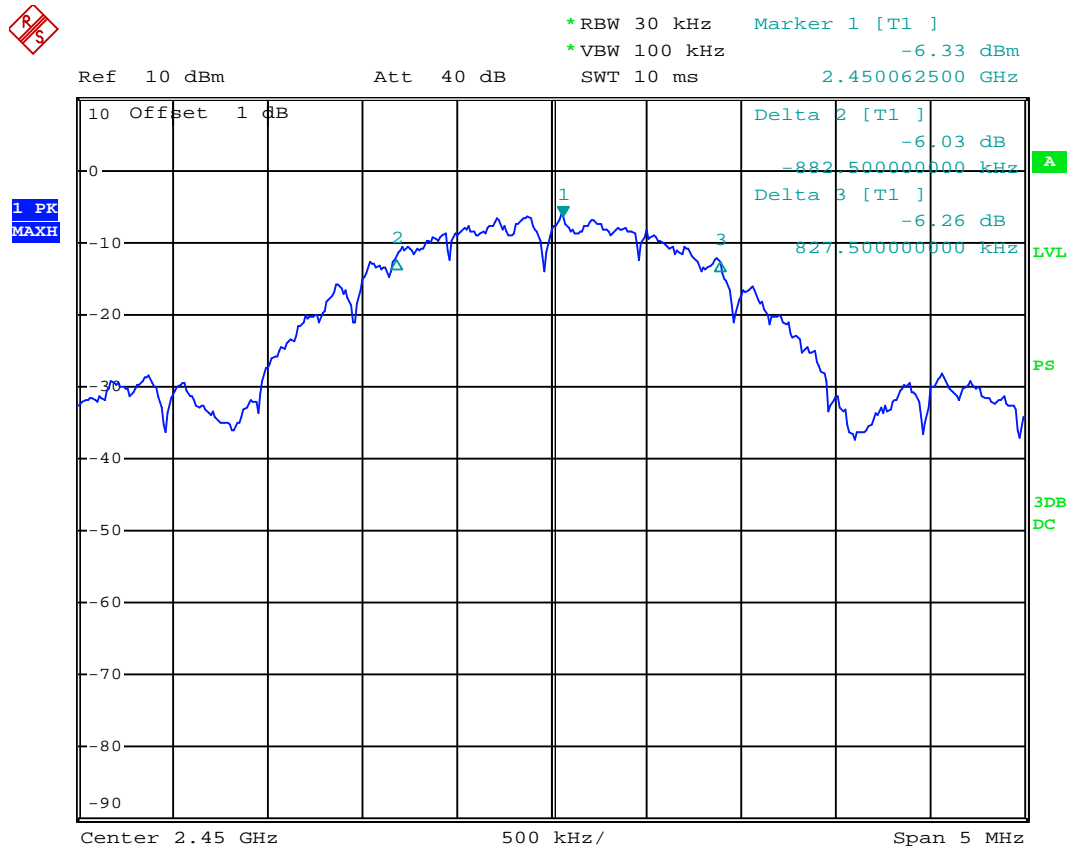

### Ch 05 (2480 MHz)

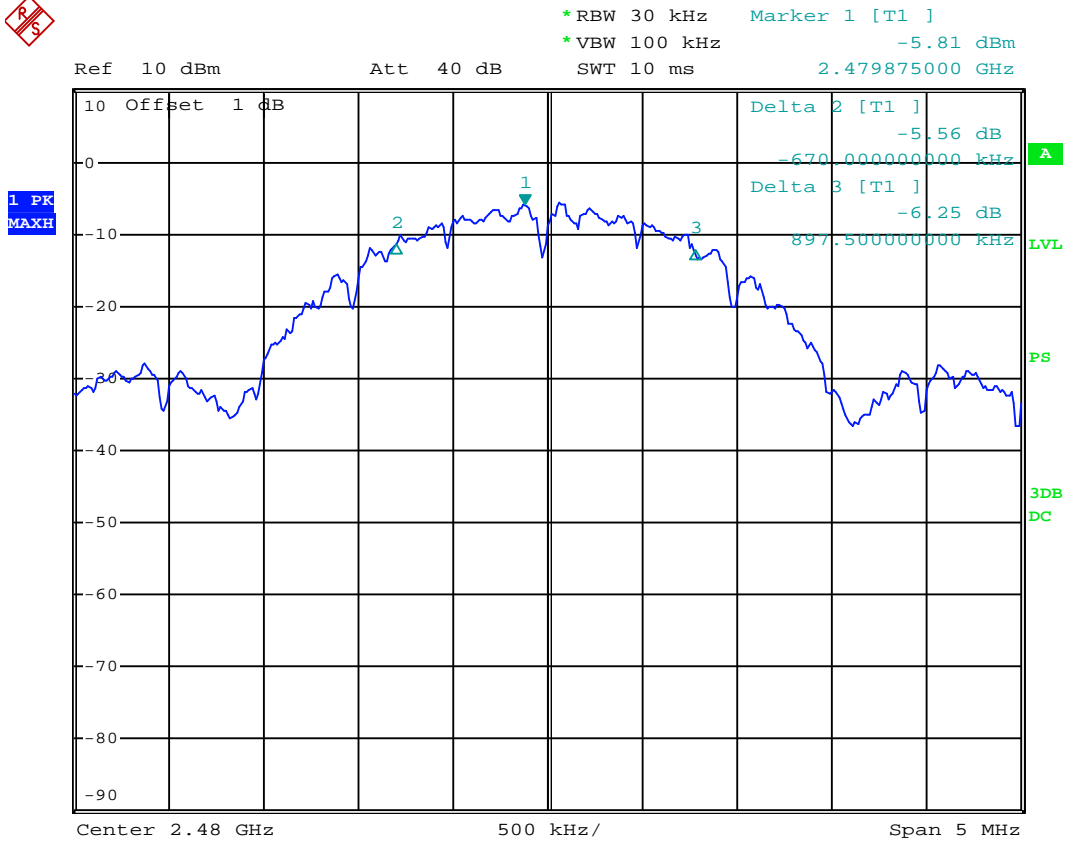

## 6 MAXIMUM PEAK OUTPUT POWER MEASUREMENT

### 6.1 Test Equipment

The following test equipment was used during the maximum peak output power measurement:

Item	Type	Manufacturer	Model No.	Serial No.	Last Cal.	Next Cal.
1.	Power Meter	Anritsu	ML2487A	6K00003245	Mar 28, 2012	Mar 28, 2013
2.	Power Sensor	Anritsu	MA2491A	32489	Mar 28, 2012	Mar 28, 2013

### 6.2 Block Diagram of Test Setup



### 6.3 Specification Limits ((§15.247(b)(3))

The Limits of maximum Peak Output Power for digital modulation in 2400-2483.5 MHz is: 1 Watt. (30 dBm)

### 6.4 Operating Condition of EUT

Enable the EUT to transmit data at different channel frequency individually.

### 6.5 Test Procedure

This is an RF conducted test. Use a direct connection between the antenna port of the transmitter and the power meter, through suitable attenuation. The transmitter output was connected to the power meter that was designed to detect peak value automatically.

Note: The bandwidth of the power meter is 20MHz.

### 6.6 Test Results

**PASSED.**

(Test Date: Feb. 21, 2013 Temperature: 25°C Humidity: 48 %)

Channel	Frequency	Peak Output Power	Limit
01	2405 MHz	<b>1.10 dBm</b>	30 dBm
03	2450 MHz	<b>0.82 dBm</b>	30 dBm
05	2480 MHz	<b>0.64 dBm</b>	30 dBm

## 7 EMISSION LIMITATIONS MEASUREMENT

### 7.1 Test Equipment

The following test equipment was used during the emission limitations test :

Item	Type	Manufacturer	Model No.	Serial No.	Last Cal.	Next Cal.
1.	Spectrum Analyzer	Agilent	E7405A	MY45106600	Mar 22, 2012	Mar 22, 2013

### 7.2 Block Diagram of Test Setup

The same as Section. 4.2.

### 7.3 Specification Limits (§15.247(d))

In any 100 kHz bandwidth outside the frequency band in which the spread spectrum or digitally modulated intentional radiator is operating, the radio frequency power that is produced by the intentional radiator shall be at least 20 dB below that in the 100 kHz bandwidth within the band that contains the highest level of the desired power, based on either an RF conducted or a radiated measurement. Attenuation below the general limits specified in Section 15.209(a) is not required.

In addition, radiated emissions which fall in restricted bands, as defined in Section 15.205(a), must also comply with the radiated emission limits specified in Section 15.209(a) (See Section 15.205(c)).(※This test result attaching to Section. 4.7)

### 7.4 Operating Condition of EUT

Enable the EUT to transmit data at different channel frequency individually.

### 7.5 Test Procedure

The transmitter output was connected to the spectrum analyzer. Set RBW = 100 kHz, VBW  $\geq$  300 kHz, scan up through 10<sup>th</sup> harmonic. All harmonics/spurs must be at least 20 dB down from the highest emission level within the authorized band as measured with a 100 kHz RBW.

The test procedure is defined in KDB558074 v02:2012 (the 10.1.2 Unwanted Emission Level Measurement was used).

### 7.6 Test Results

**PASSED.**

The test data was attached in the next pages.

(Test Date: Feb. 21, 2013 Temperature: 25°C Humidity: 48 %)

**Ch 01 (2405 MHz)**

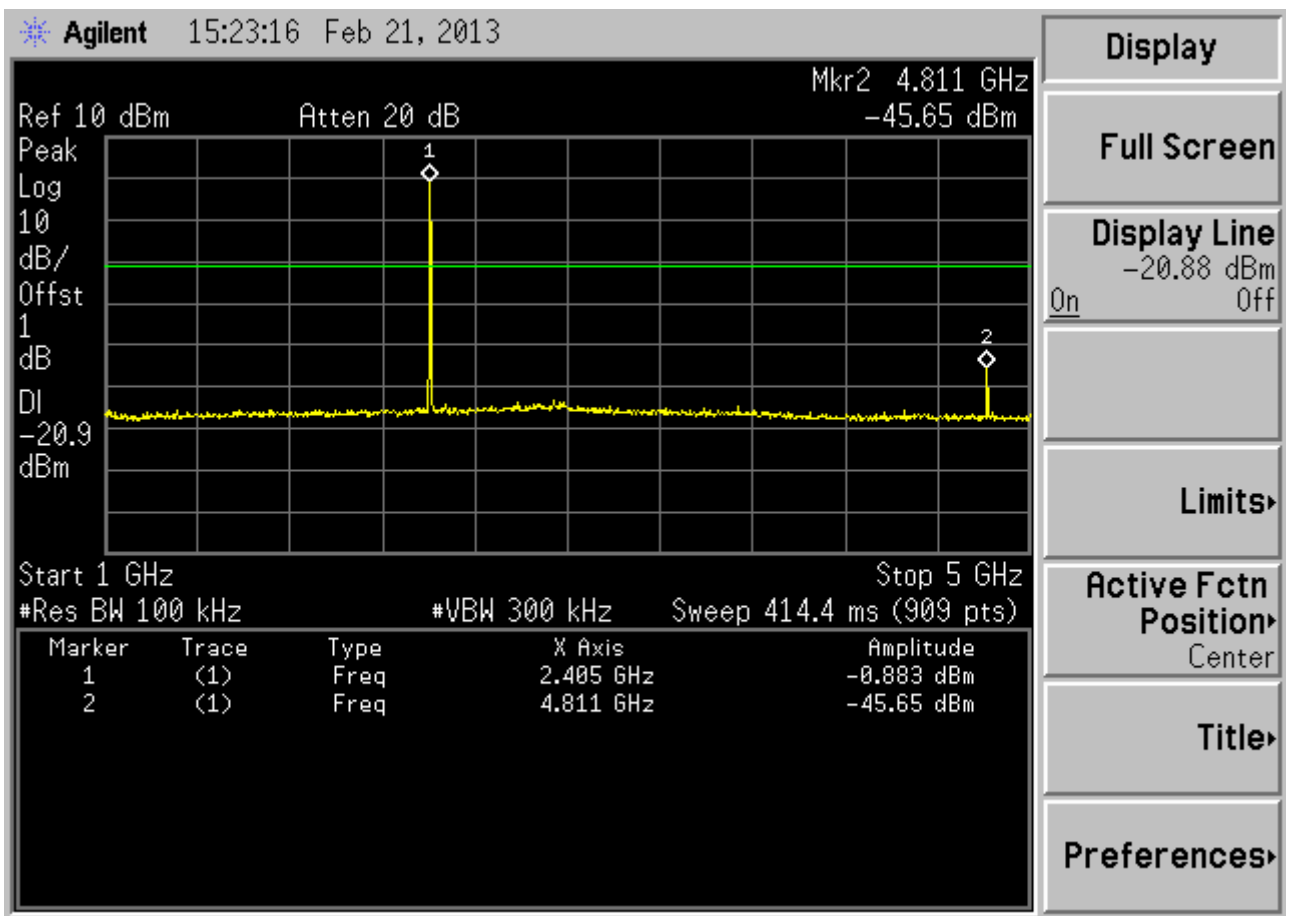
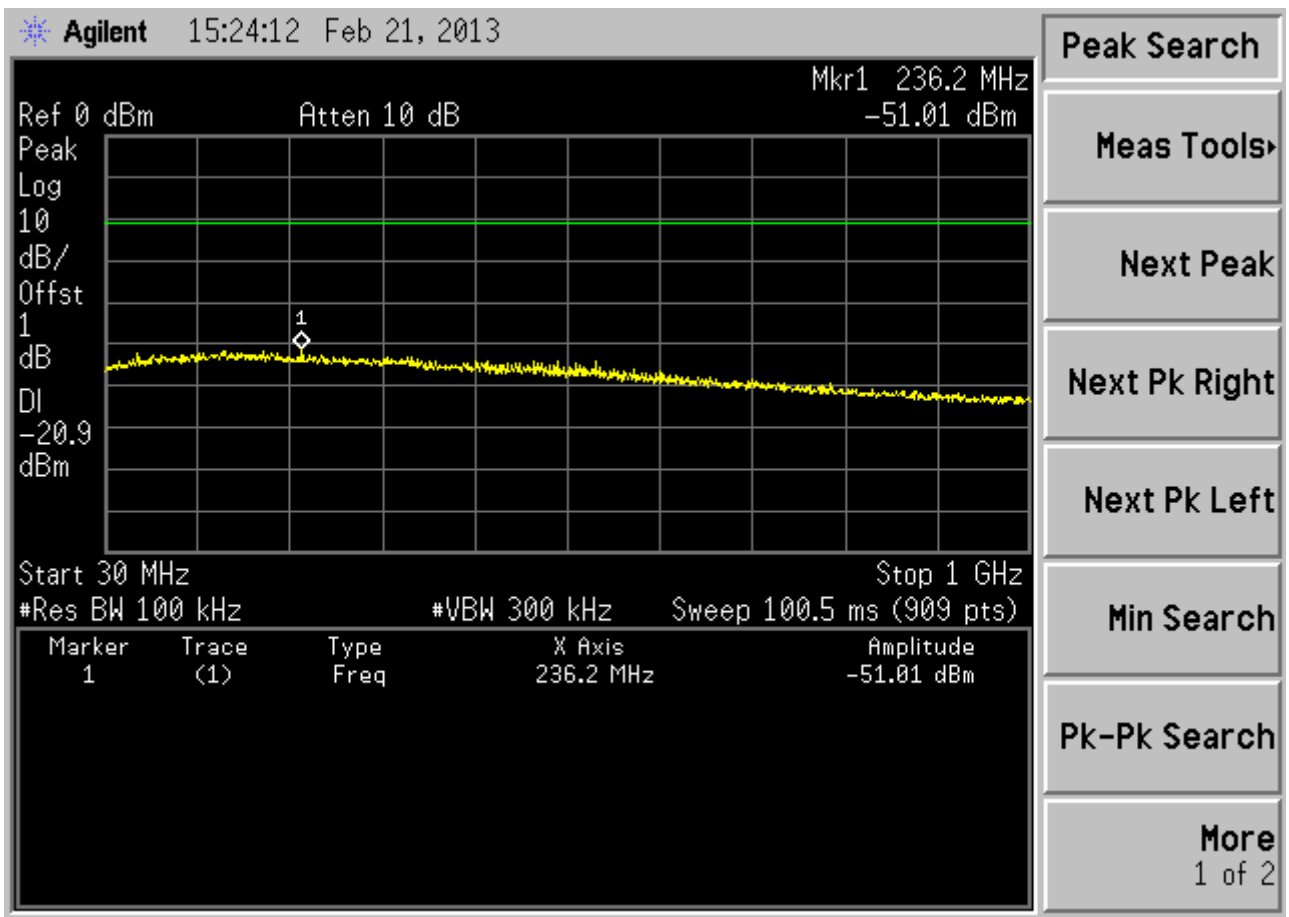



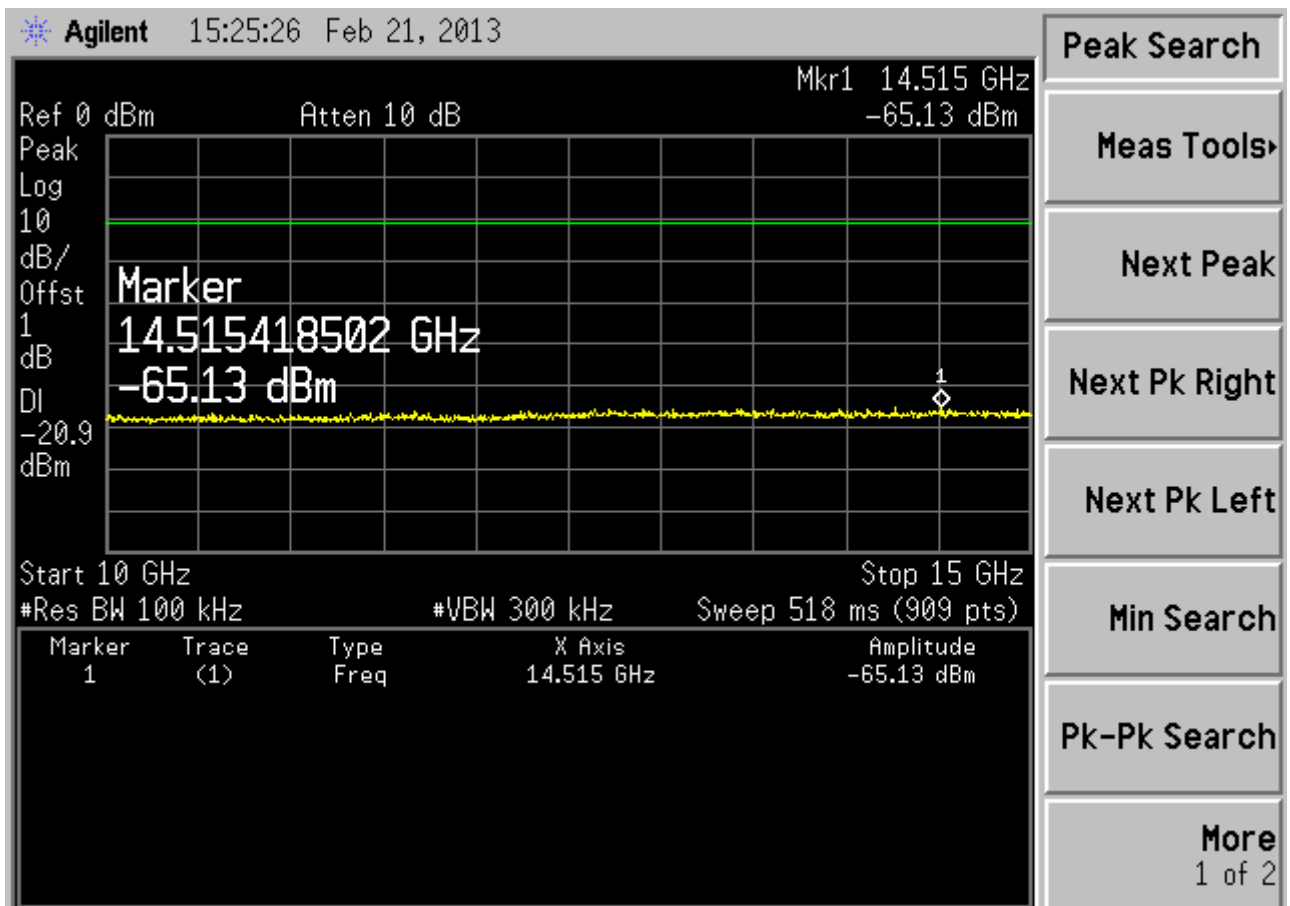
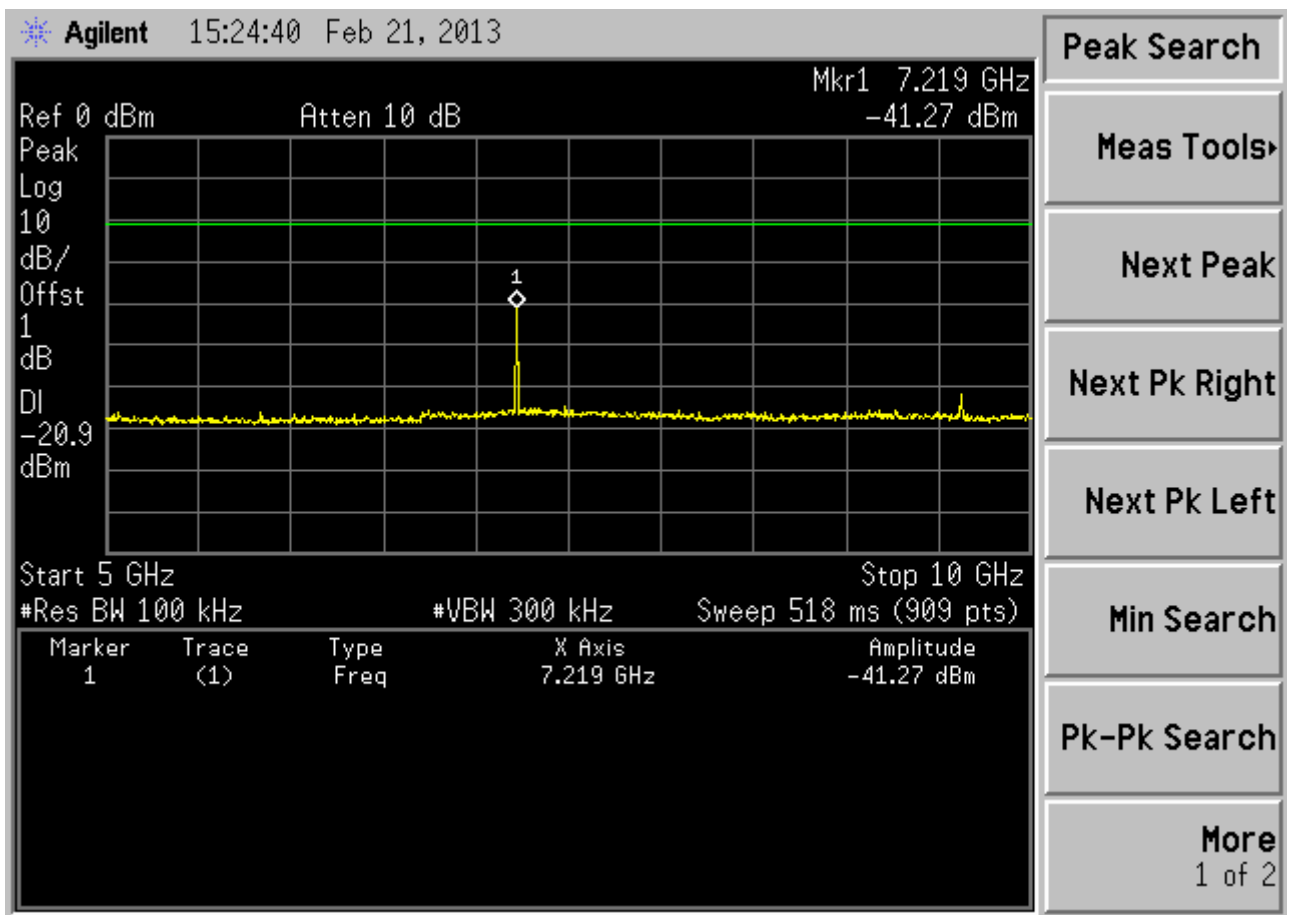

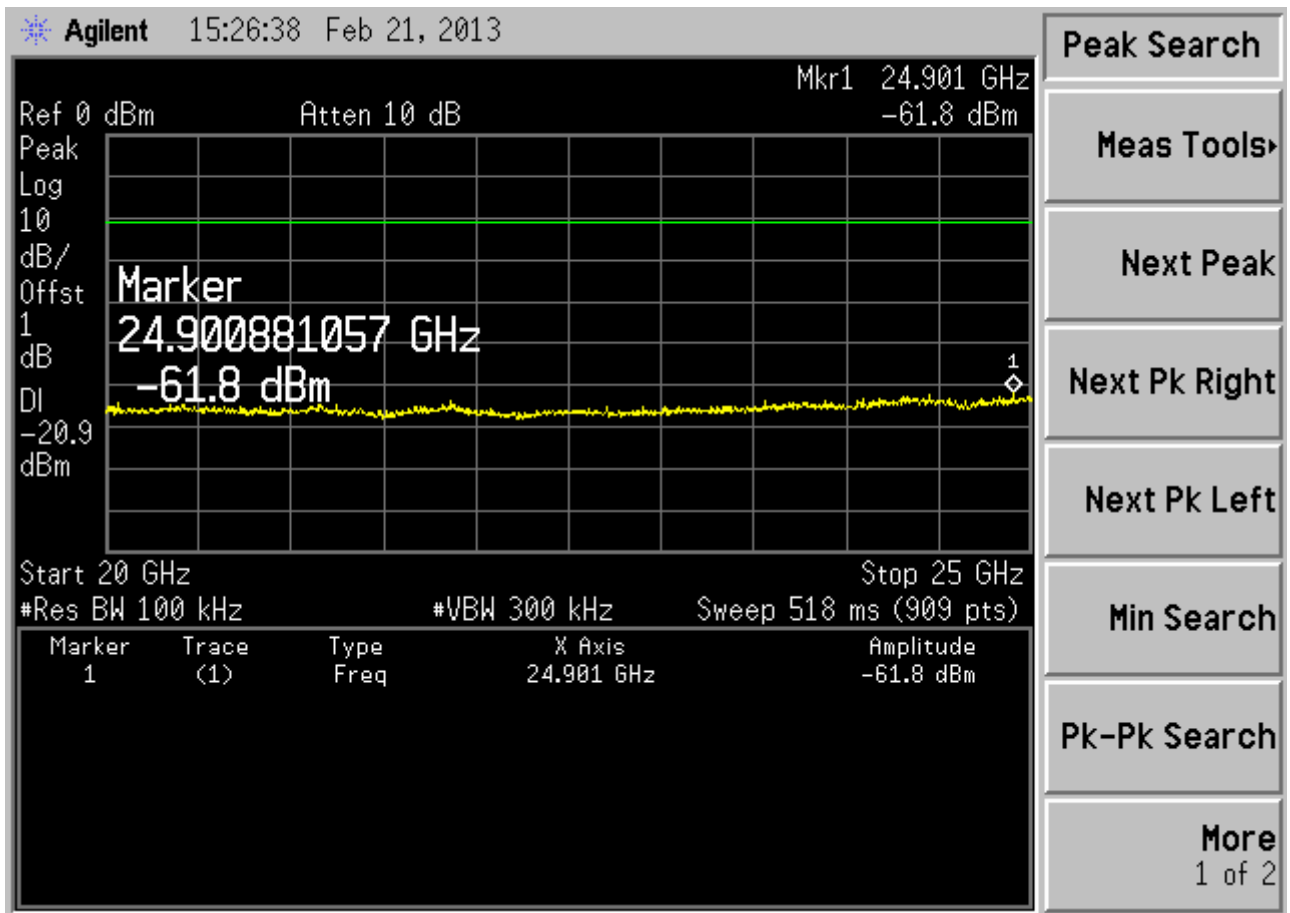
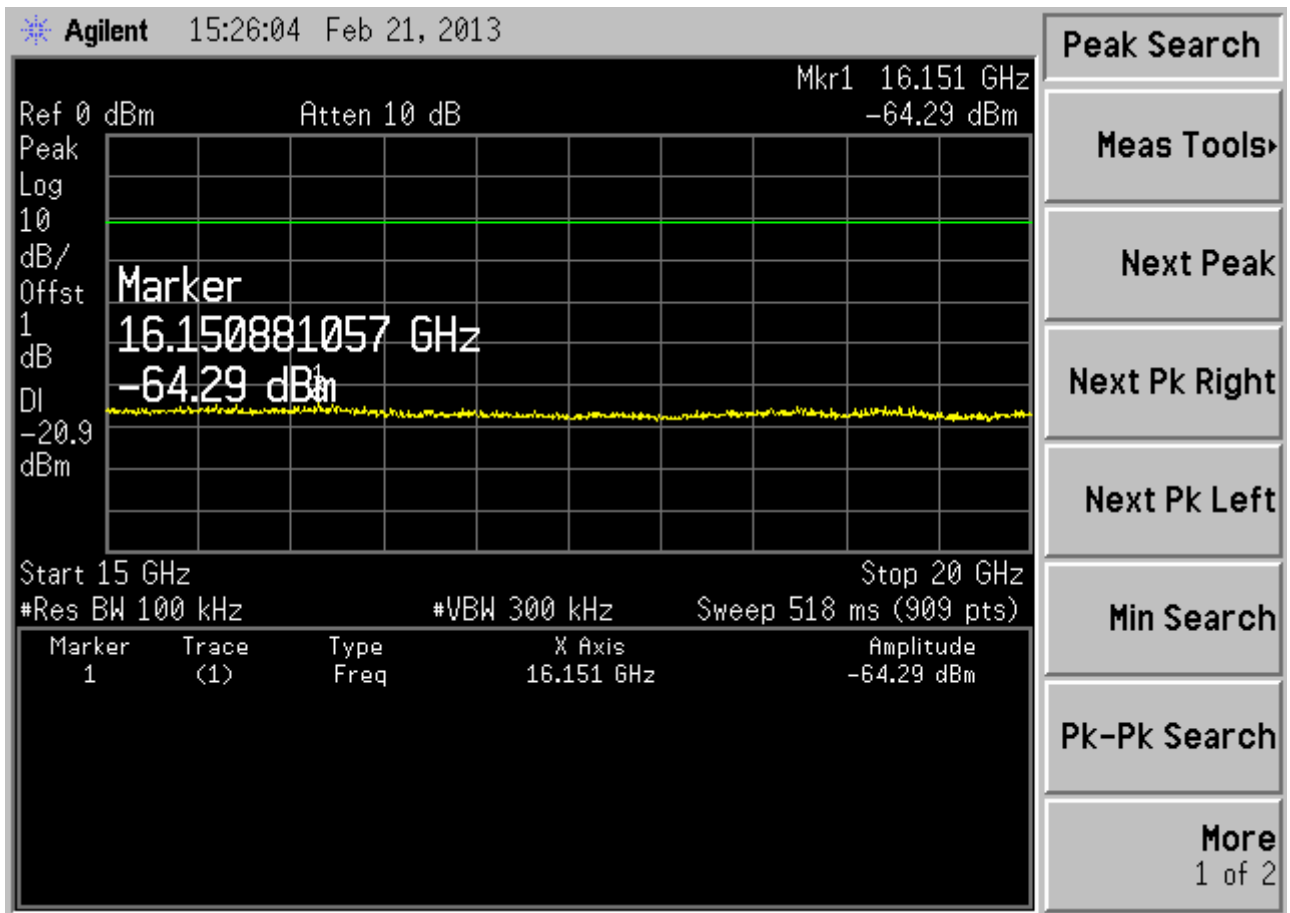

**Ch 03 (2450 MHz)**

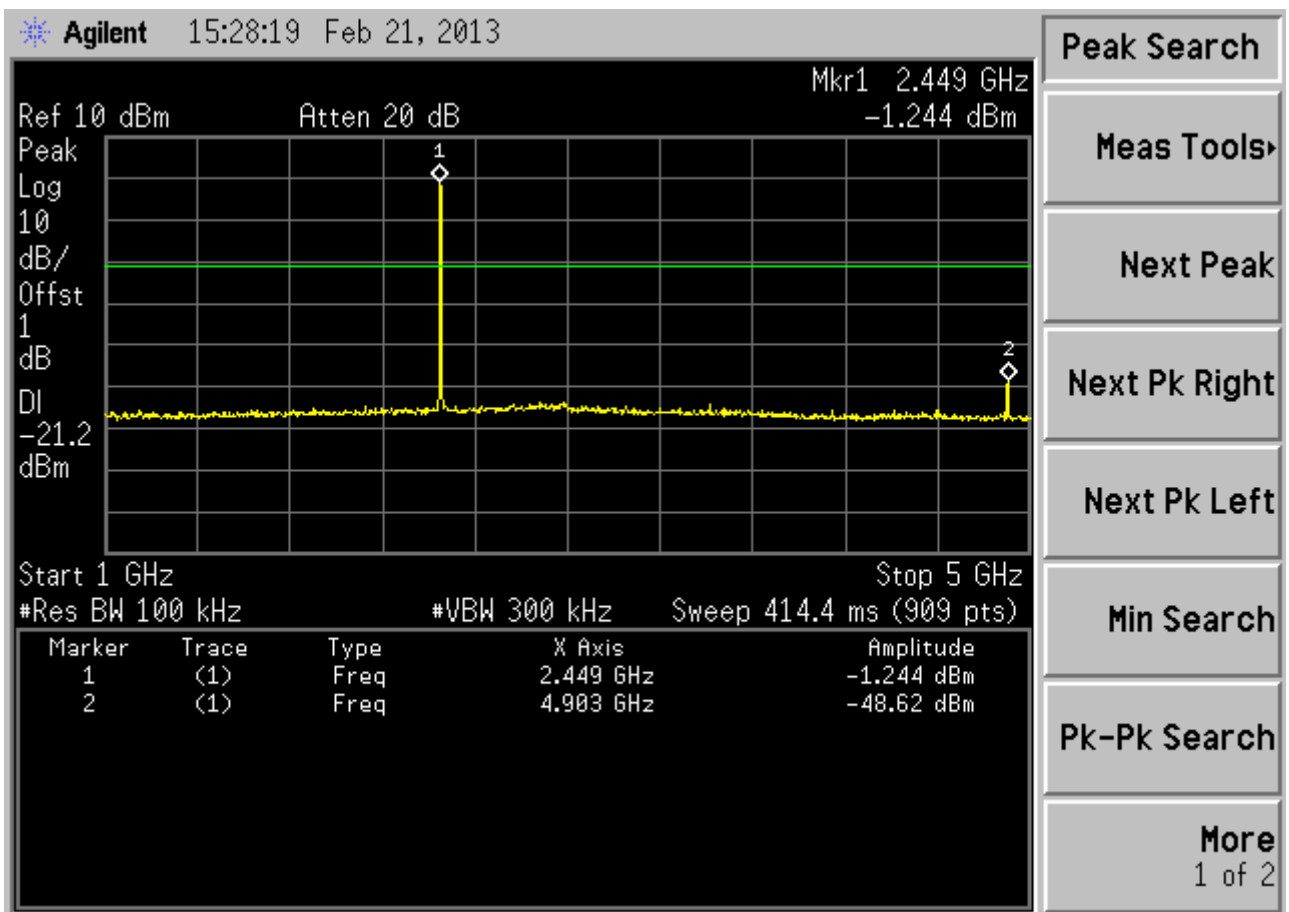
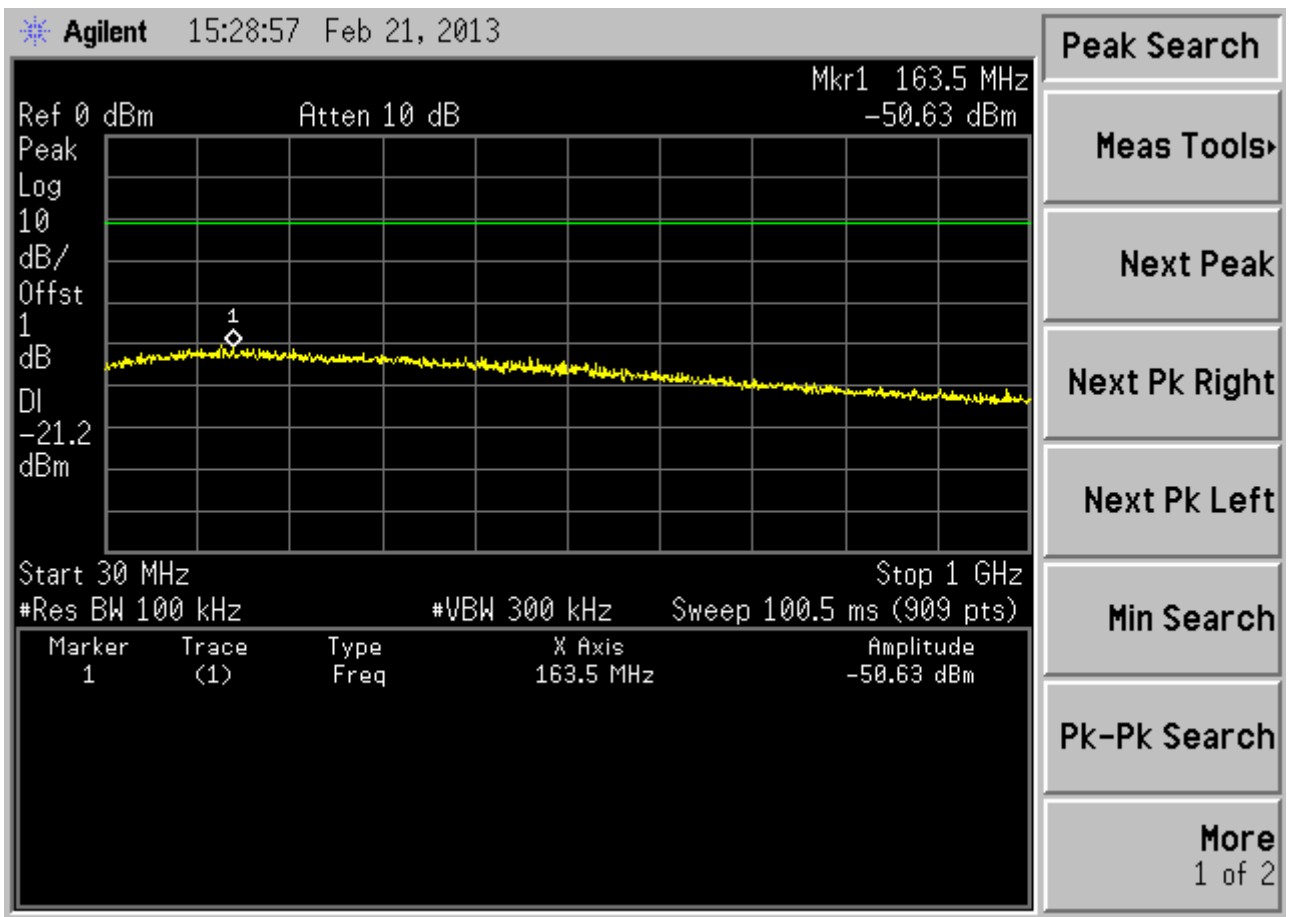

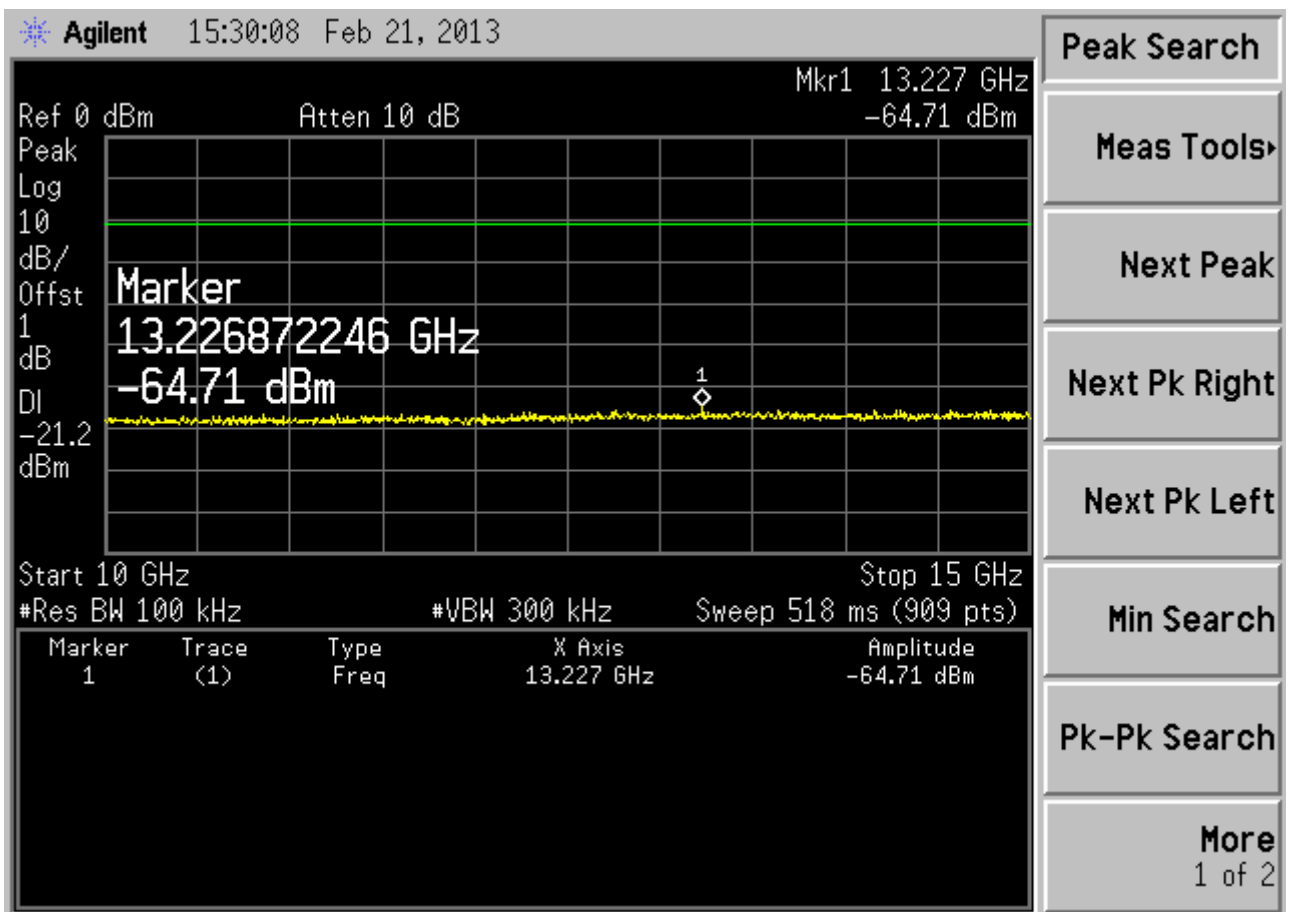
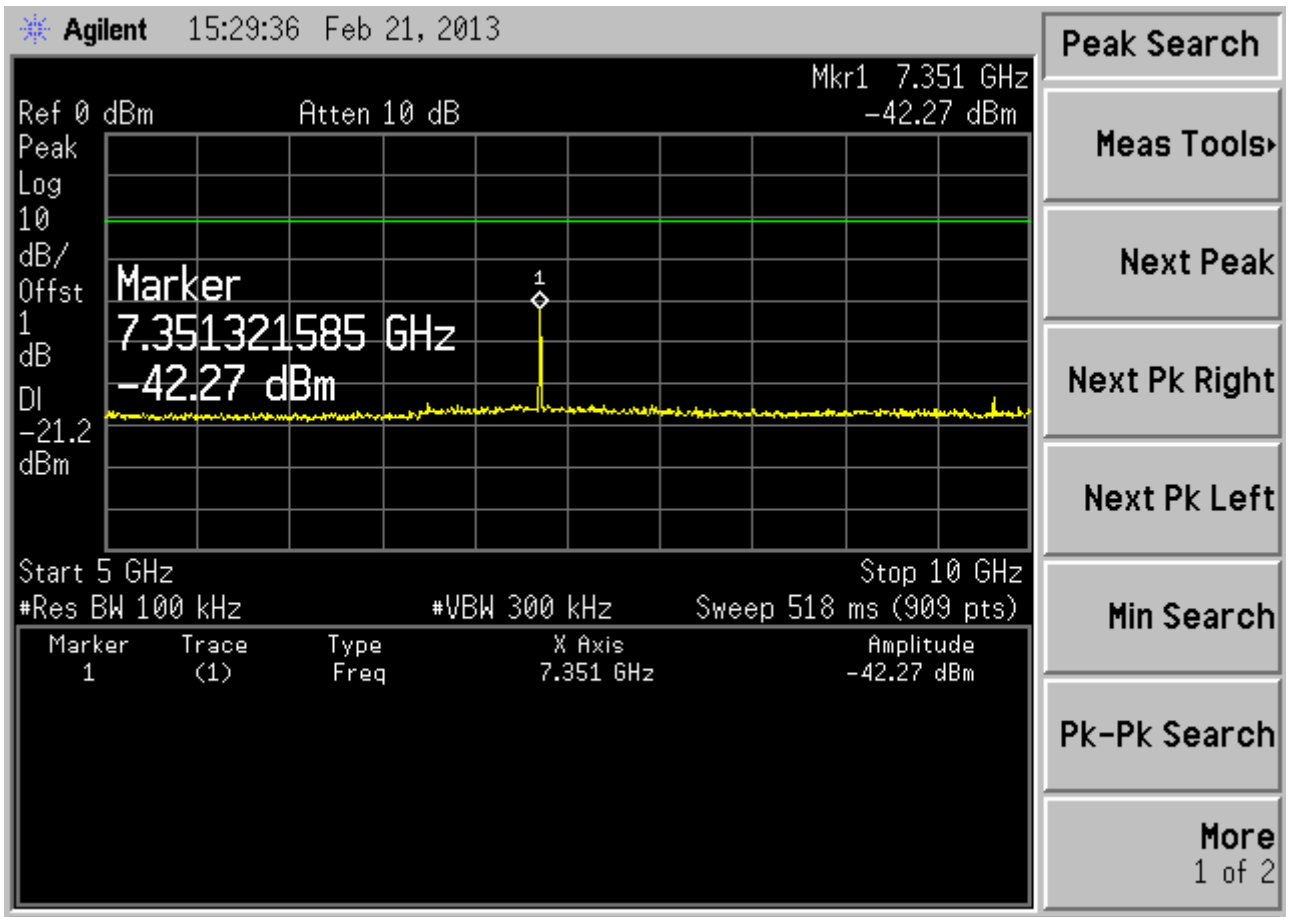

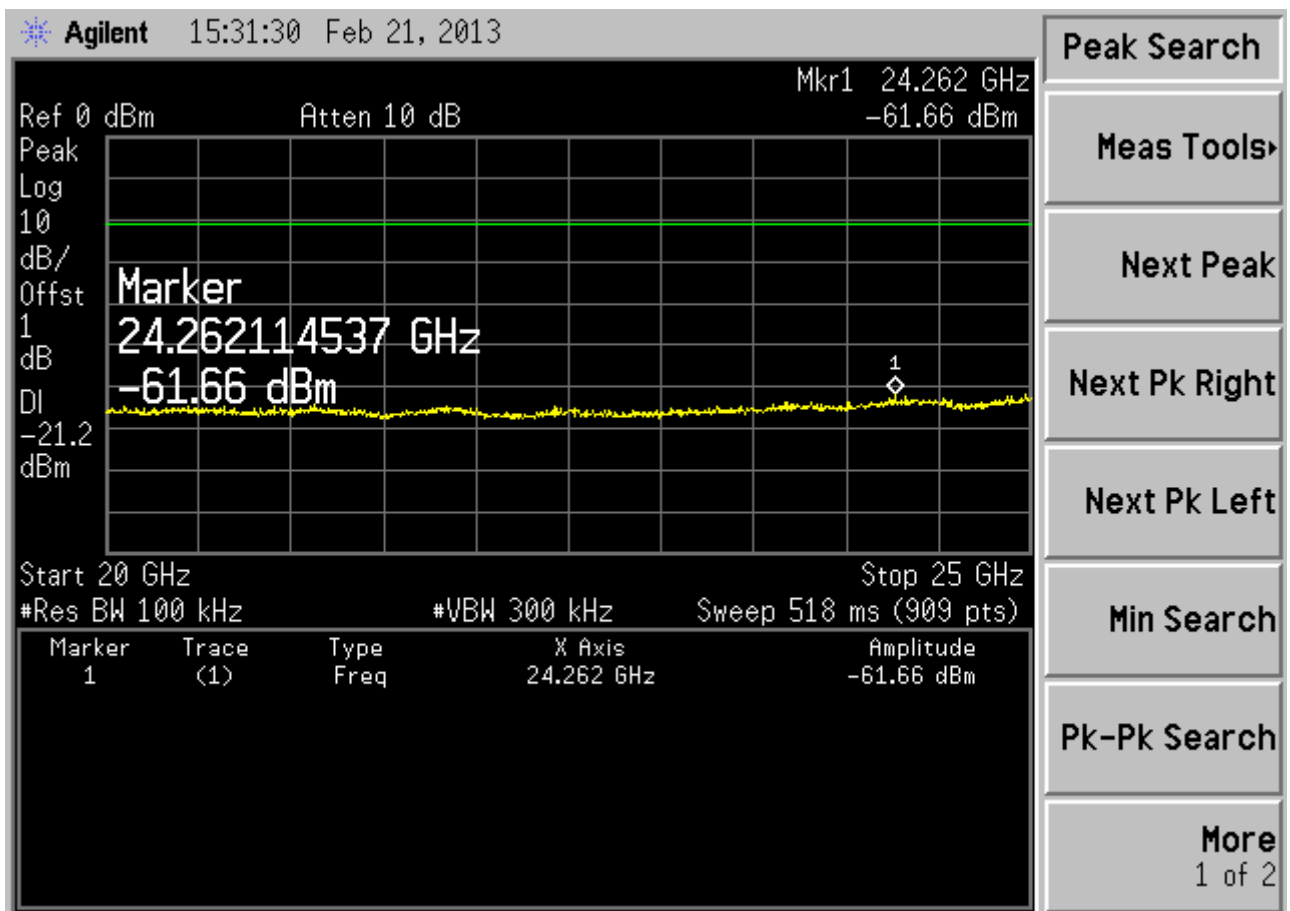
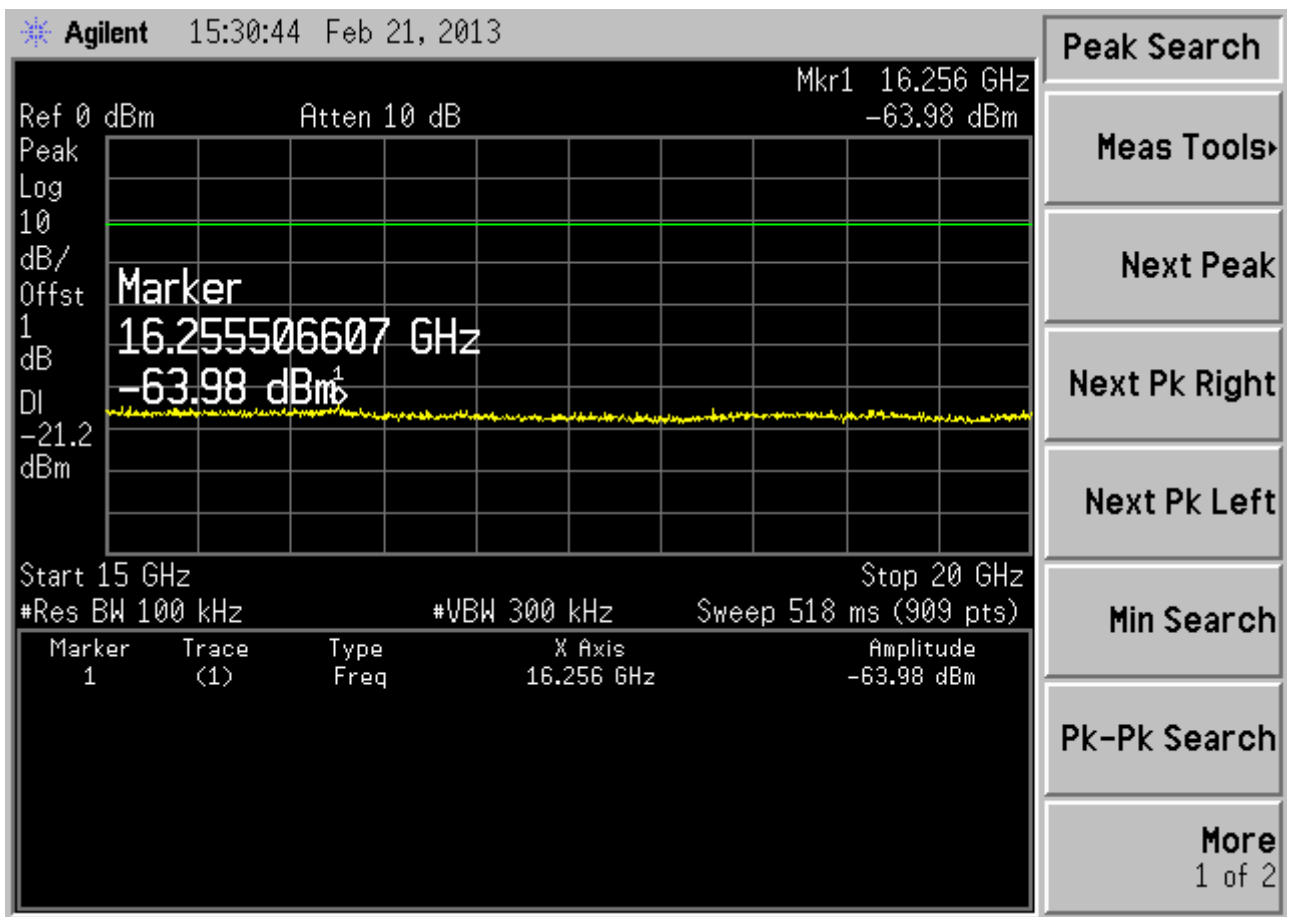

### Ch 05 (2480 MHz)

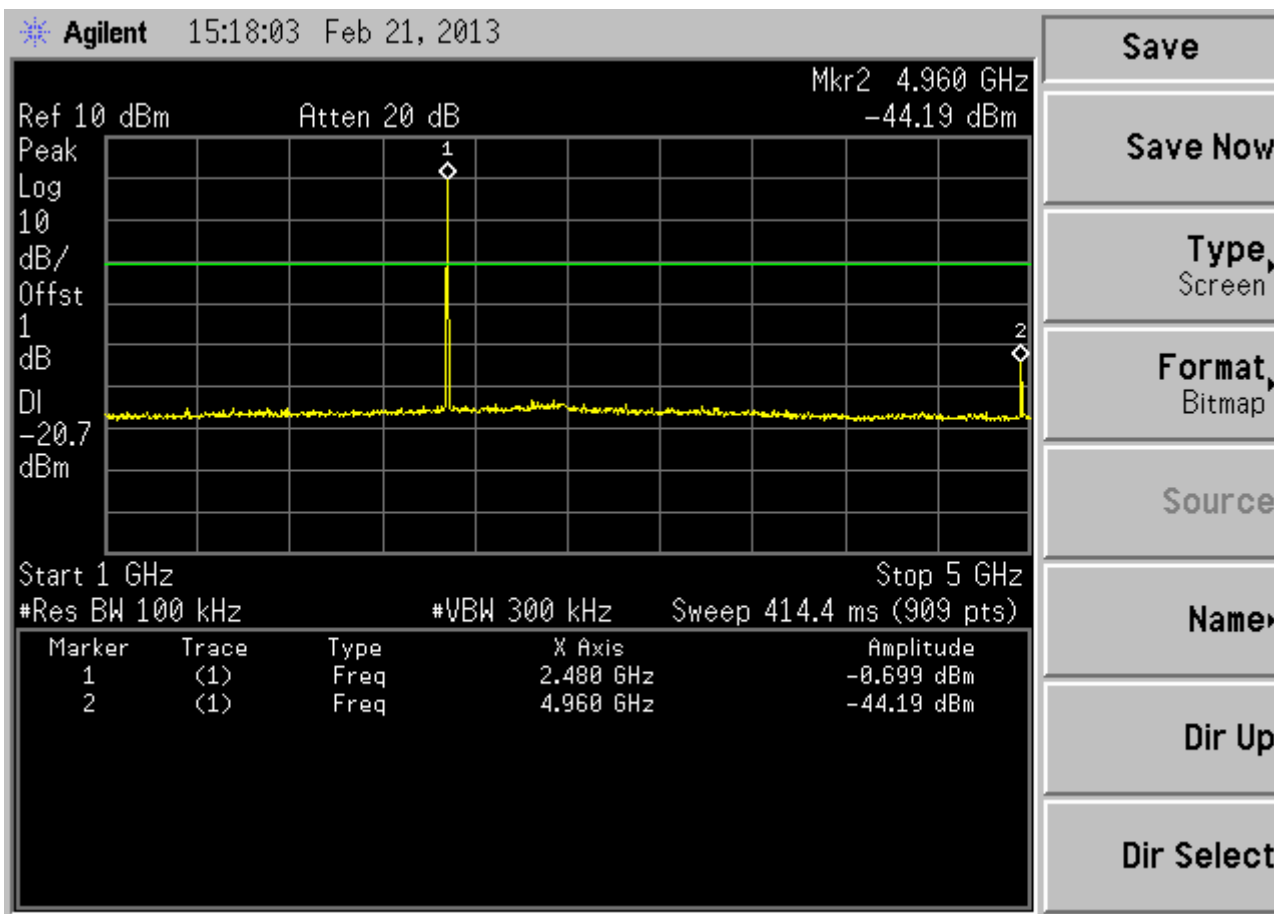
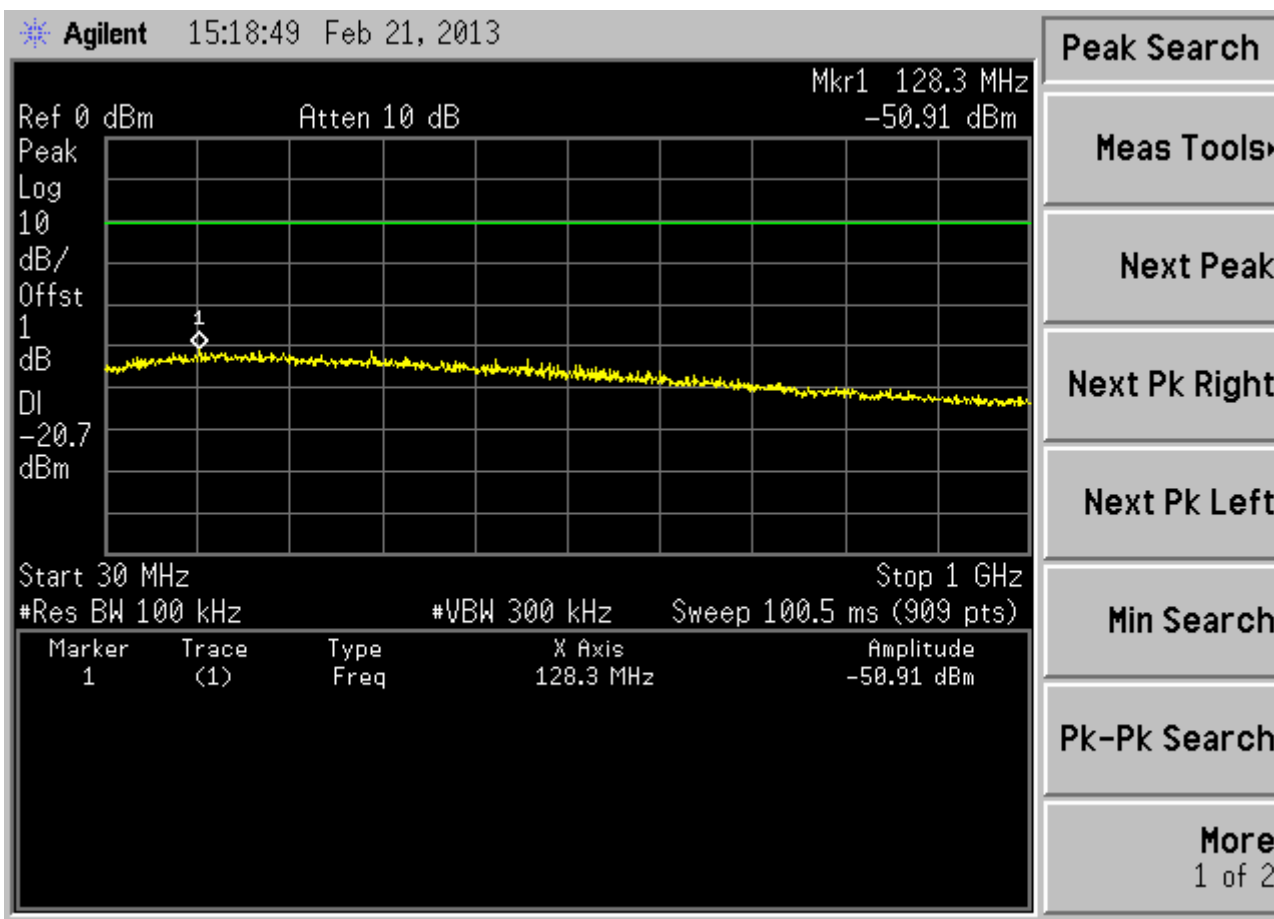

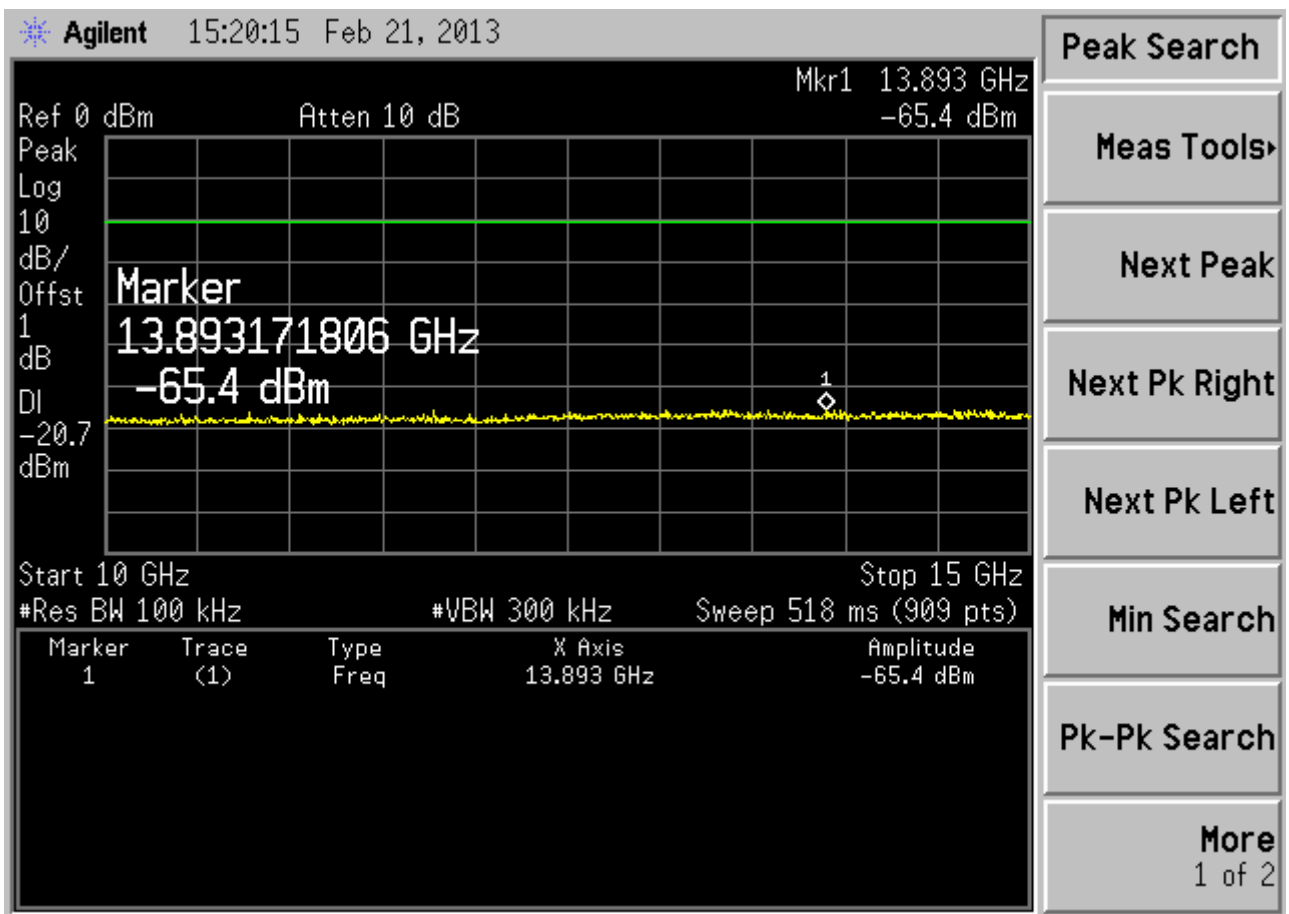
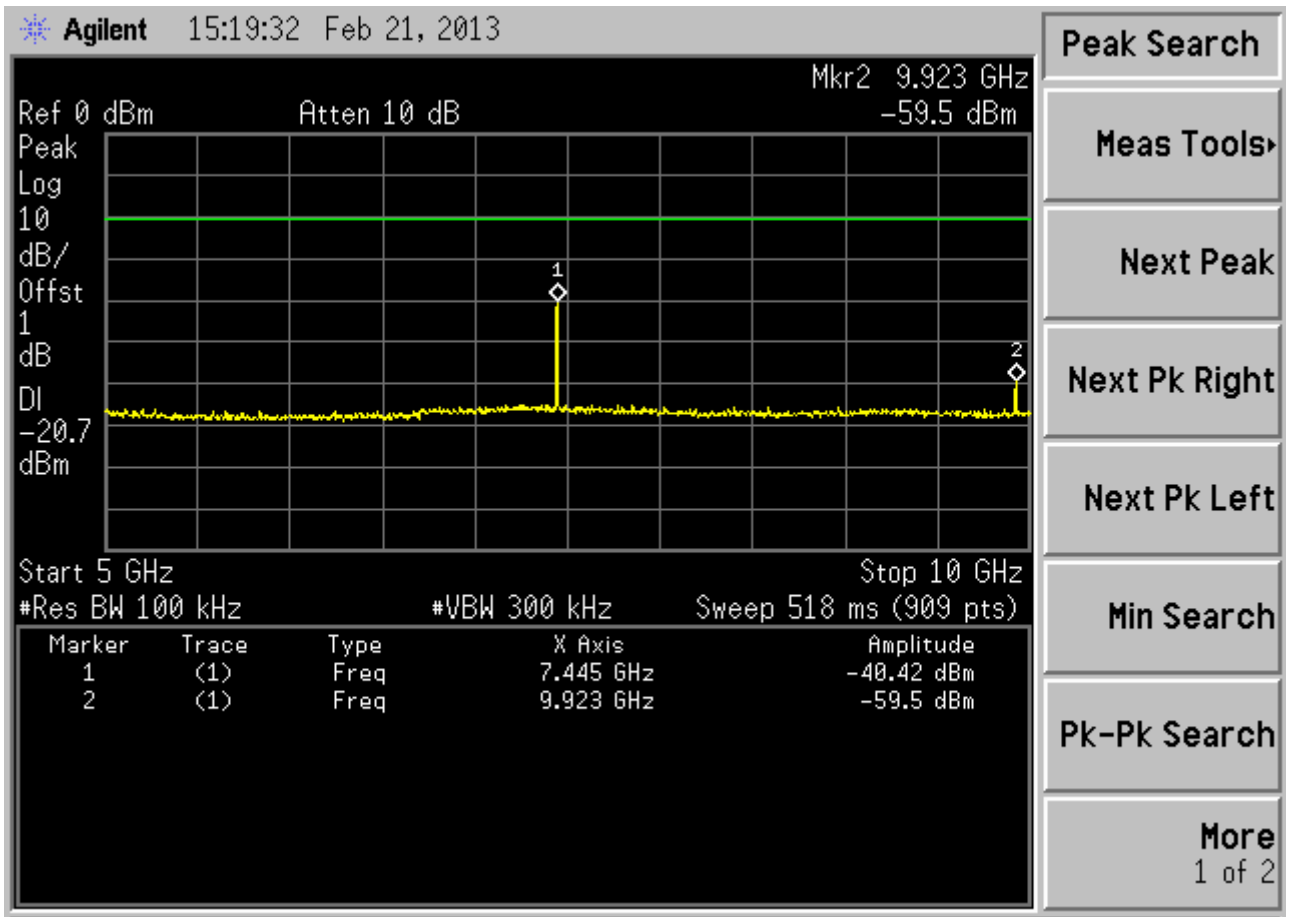

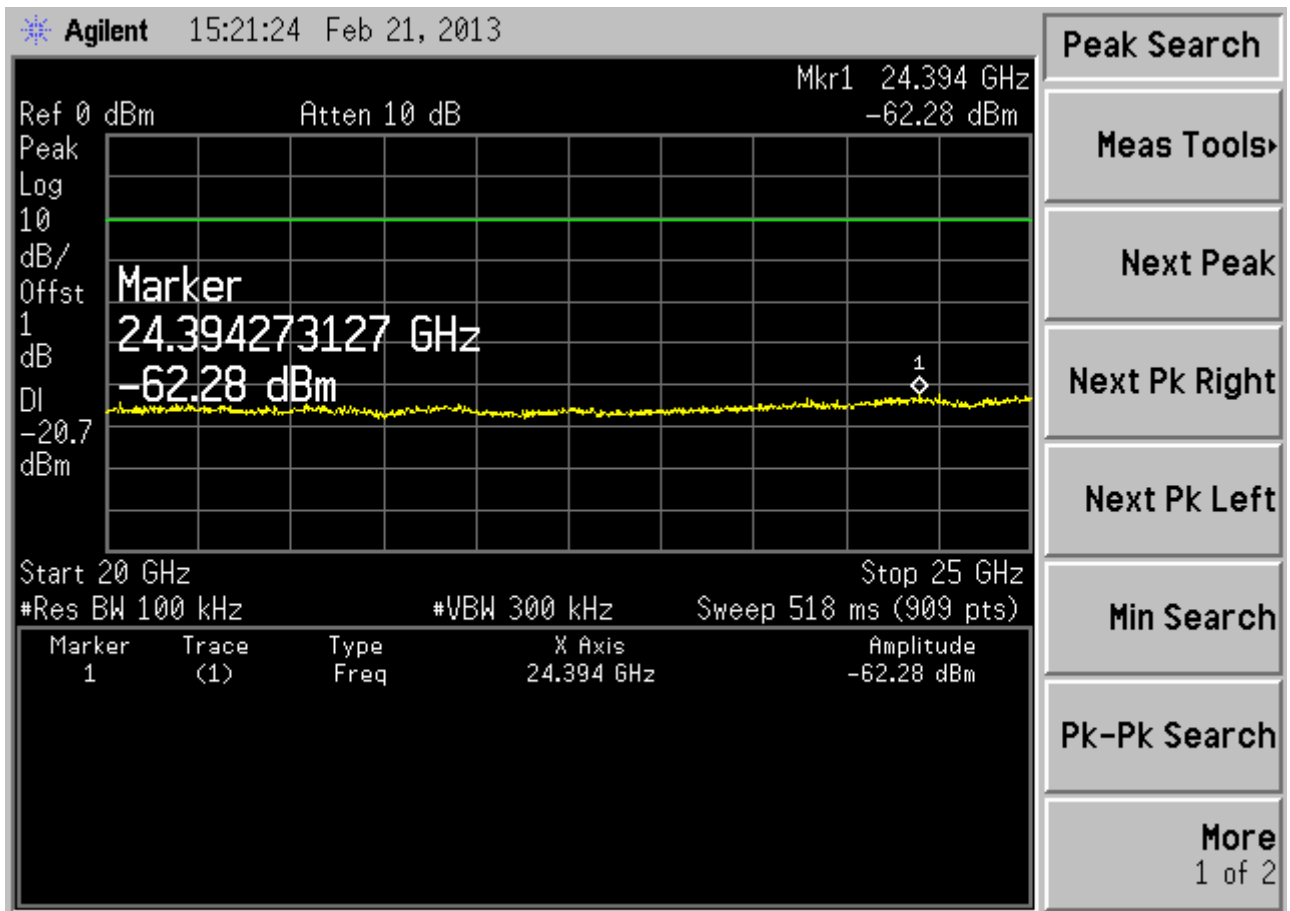
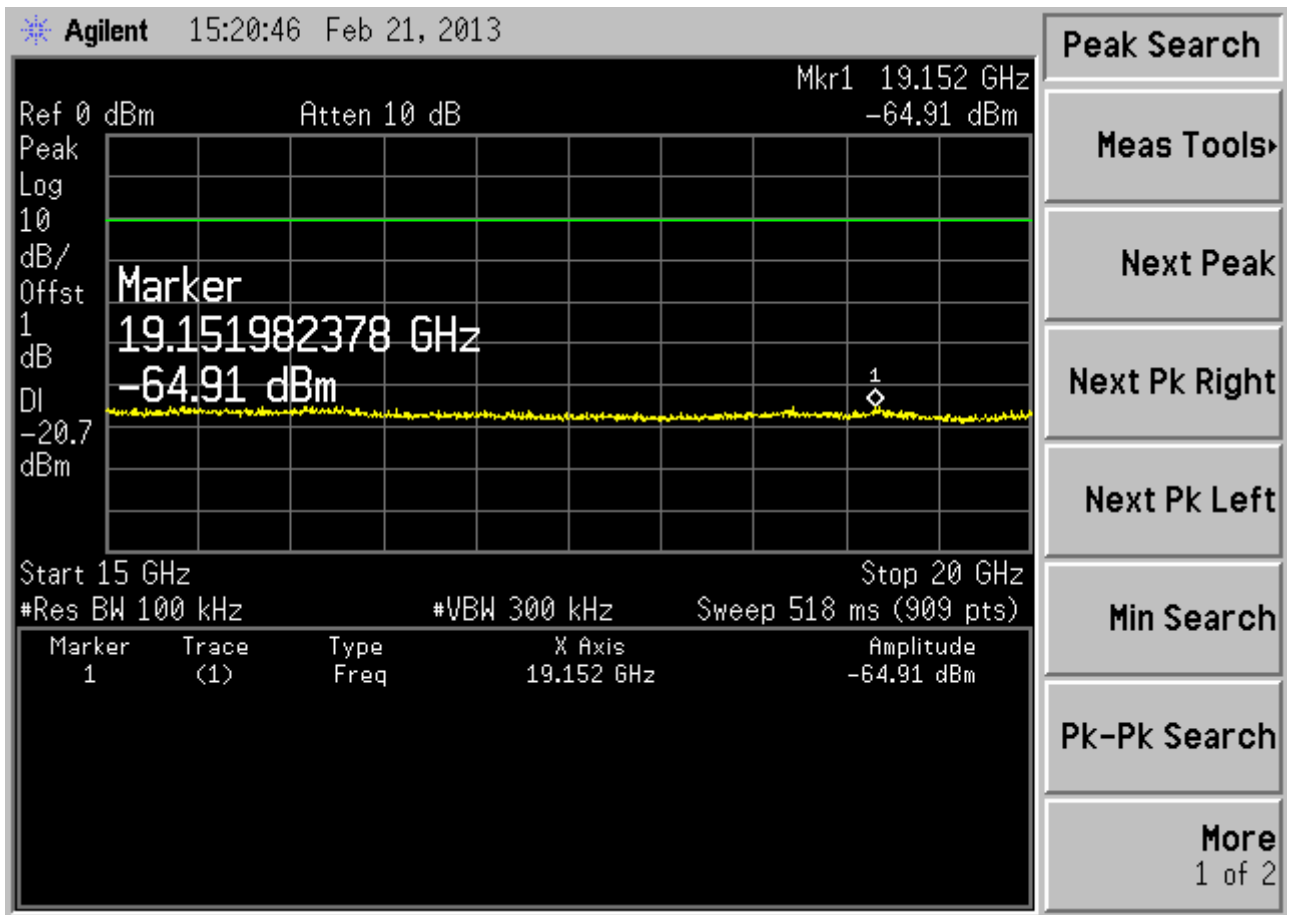



## 8 BAND EDGES MEASUREMENT

### 8.1 Test Equipment

The following test equipment was used during the band edges measurement:

Item	Type	Manufacturer	Model No.	Serial No.	Last Cal.	Next Cal.
1.	Test Receiver	R&S	ESCI	101303	Sep 11, 2012	Sep 11, 2013

### 8.2 Block Diagram of Test Setup

The same as section 5.2.

### 8.3 Specification Limits (§15.247(d))

In any 100 kHz bandwidth outside the frequency band in which the spread spectrum or digitally modulated intentional radiator is operating, the radio frequency power that is produced by the intentional radiator shall be at least 20 dB below that in the 100 kHz bandwidth within the band that contains the highest level of the desired power, based on either an RF conducted or a radiated measurement, provided the transmitter demonstrates compliance with the peak conducted power limits.

### 8.4 Operating Condition of EUT

Enable the EUT to transmit and receive data at different channel frequency individually.

### 8.5 Test Procedure

The transmitter output was connected to the test receiver / spectrum analyzer. Set RBW of spectrum analyzer to 100kHz and VBW to 300kHz with suitable frequency span including 100kHz bandwidth from band edge.

### 8.6 Test Results

**PASSED.** All the test results are attached in next pages.

(Test Date: Feb. 21, 2013 Temperature: 25°C Humidity: 48 %%)

Location	Channel	Frequency	Delta Marker	Result
Below Band Edge	01	2405 MHz	<b>49.24 dB</b>	More than <b>20 dB</b> below the highest level of the desired power
Upper Band Edge	05	2480 MHz	<b>46.42 dB</b>	

### Ch01 2405MHz (Below Edge 2400 MHz)

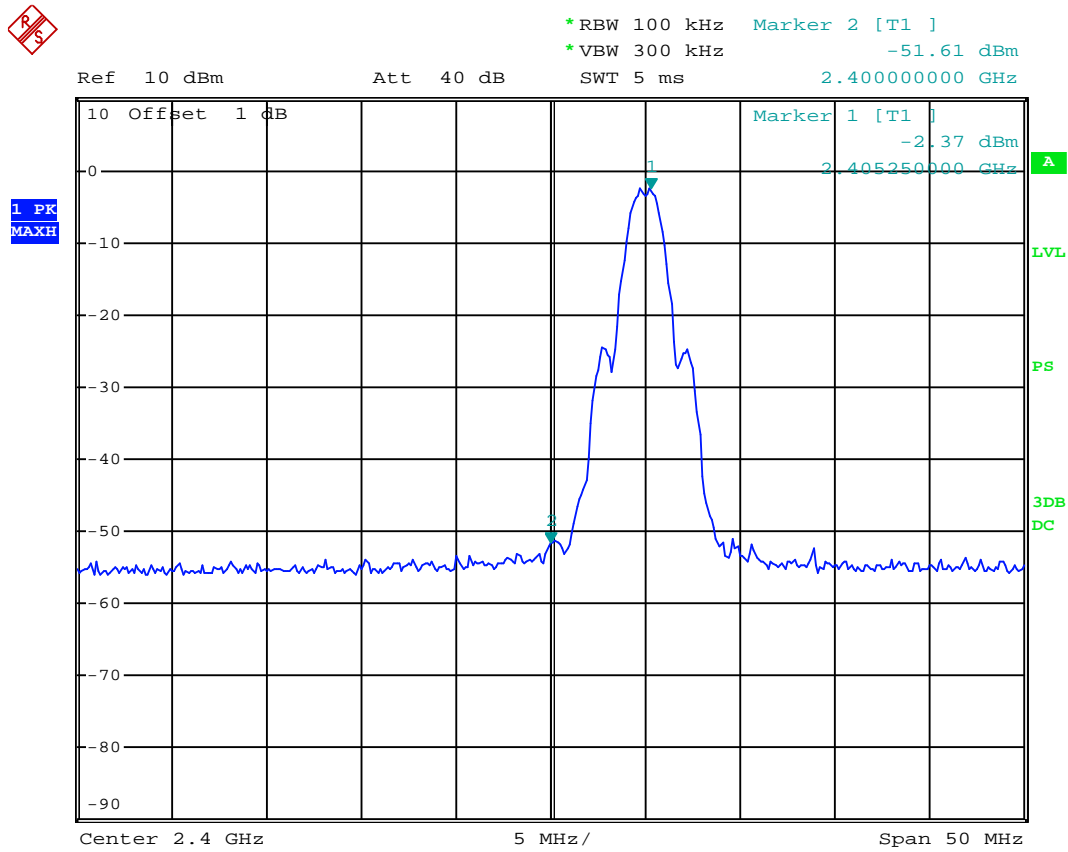

### Ch05 2480MHz (Upper Edge 2483.5 MHz)

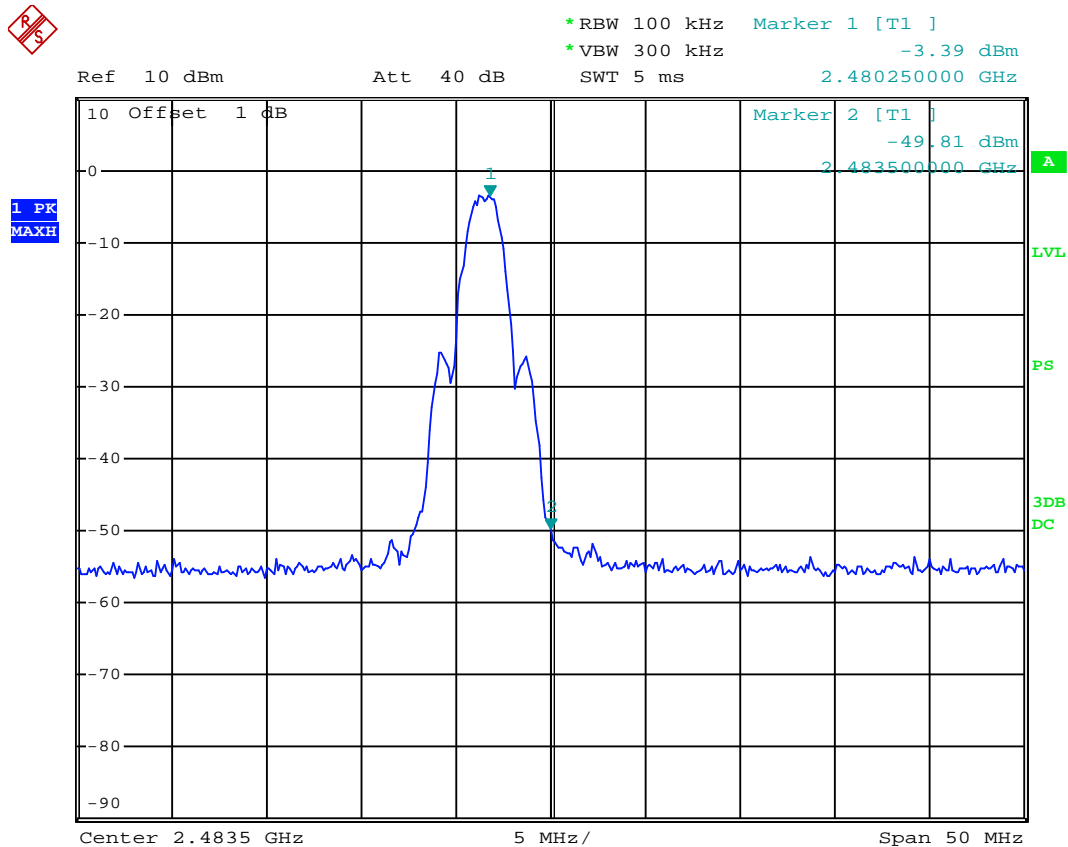

## 9 POWER SPECTRAL DENSITY MEASUREMENT

### 9.1 Test Equipment

The following test equipment was used during the power spectral density measurement:

Item	Type	Manufacturer	Model No.	Serial No.	Last Cal.	Next Cal.
1.	Test Receiver	R&S	ESCI	101303	Sep 11, 2012	Sep 11, 2013

### 9.2 Block Diagram of Test Setup

The same as section.5.2.

### 9.3 Specification Limits (§15.247(e))

The peak power spectral density conducted from the intentional radiator to the antenna shall not be greater than 8 dBm in any 3 kHz band.

### 9.4 Operating Condition of EUT

Enable the EUT to transmit data at different channel frequency individually.

### 9.5 Test Procedure

The transmitter output was connected to the test receiver / spectrum analyzer. The test receiver / spectrum analyzer was set as RBW  $\geq$  3kHz, VBW  $\geq$  3 x RBW, span = 1.5 times the DTS channel bandwidth.

The test procedure is defined in KDB558074 v02:2012 (the 9.1 Measurement Procedure "Option 1" was used).

### 9.6 Test Results

**PASSED.** All the test results are attached in next pages.

(Test Date: Feb. 21, 2013 Temperature: 25°C Humidity: 48 %)

Channel	Frequency	Power Spectral Density	Limit
01	2405 MHz	-15.50 dBm	8dBm
03	2450 MHz	-14.92 dBm	8dBm
05	2480 MHz	-14.66 dBm	8dBm

### Ch01 2405 MHz

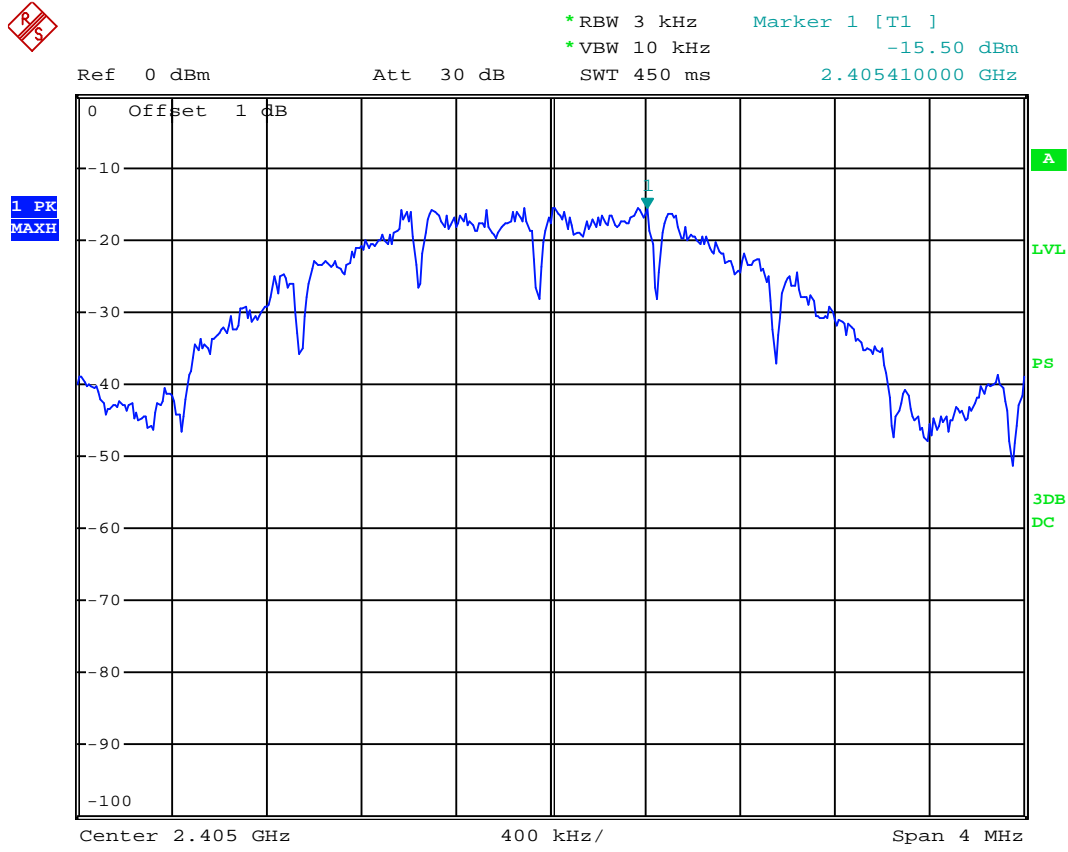

### Ch03 2450 MHz

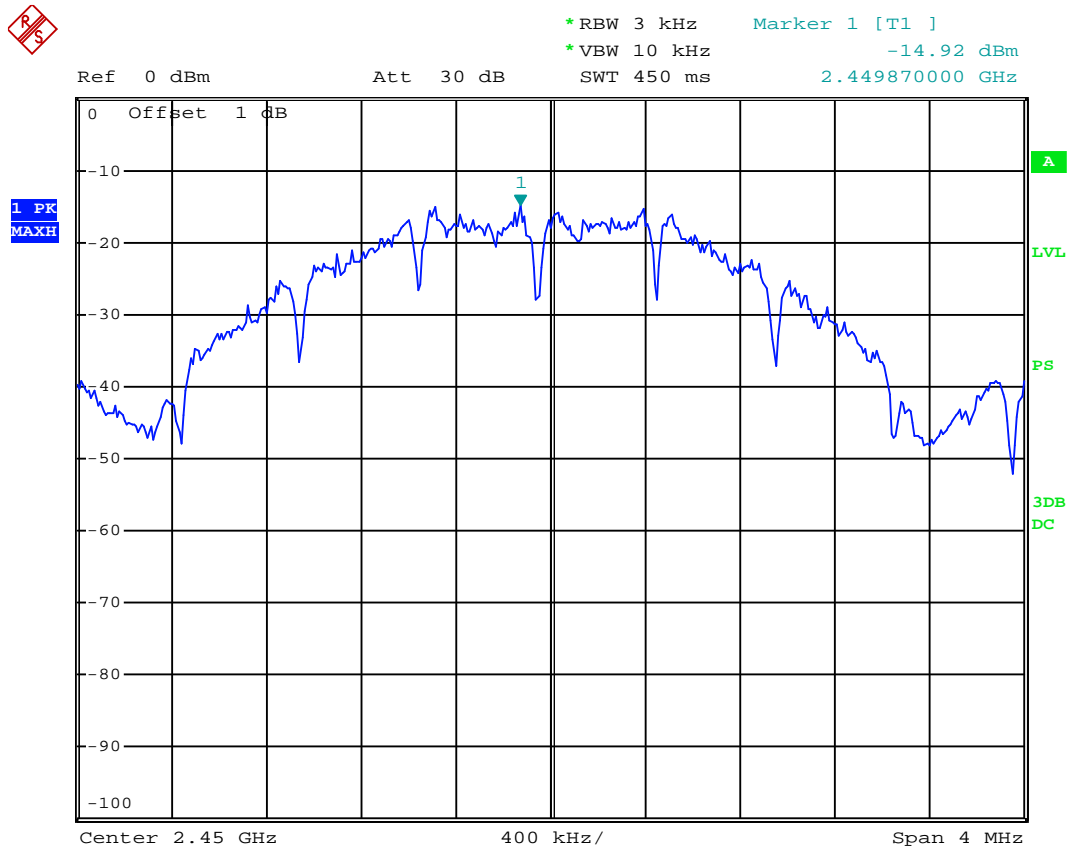

### Ch05 2480 MHz

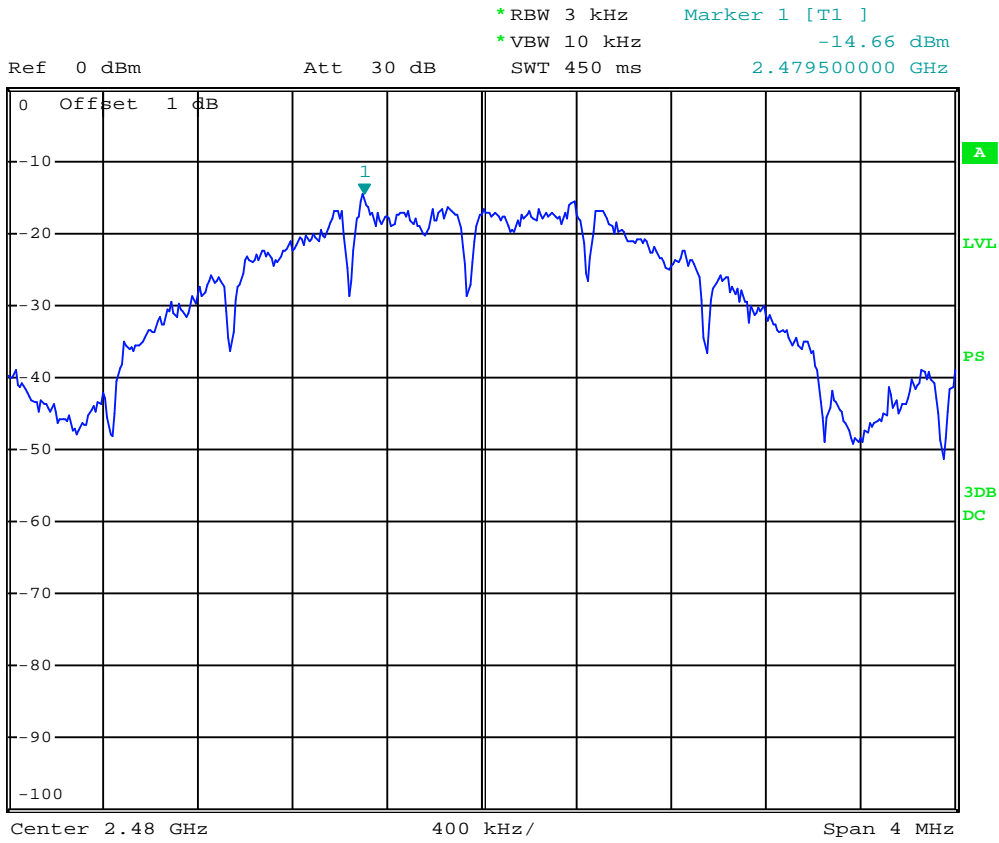

## **10 DEVIATION TO TEST SPECIFICATIONS**

None.