

## Exhibit 12

### POS Terminal

with a Research in Motion R802D-2-0 Transmitter  
DataTac/ARDIS Modem  
(FCC ID:L6AR802D-2-0, Test Data)

**MIST Inc.**

**FCC ID: O3JF2R802D1**

**Test Data/Report  
For**

**2.1049 and 2.1047(2.987): Occupied  
Bandwidth/Bandwidth Limitations**

**2.1051(2.991): Spurious Emissions at Antenna Terminal**

**2.1055(2.995): Frequency Stability**

RADIATED and CONDUCTED EMI TEST REPORT

August 27, 1999

CLIENT:

Research In Motion  
295 Phillip Street  
Waterloo, Ontario  
N2L 3W8

TESTED MODEL:

Model Number: **R802D-2-0**  
Serial Number: 128/00/000008 (Radio 08)  
Description: 800 MHz **OEM RADIO MODEM DEVICE**  
Date tested: August 16, 1999  
Tested with: Host computer, IBM ThinkPad 770ED-S97-3819-2,  
Serial # 78-X1980 09/98, FCC ID 4U6JPN-31879-DTE;  
RIM Radio Monitor [ITB] Board, PCB-02120-001 Rev  
B; ITB PCB Power Supply, AC/DC adapter, Mfr.  
Globtek, Part No. WR91A2400CCP, 05 VDC @ 2.4A;  
Antenna Company 800 MHz "Cell" antenna, Model  
Eclipse II/8110; Associated cables and cords.

IN ACCORDANCE WITH:

- **FCC Part 2 and FCC Part 90 Transmitters; Certification**
- Test procedure(s) MP-4 and ANSI C63.4
- Industry Canada OATS reference number, **IC 2963**. RSP 100, Issue 7.

TESTED BY:

Com-Serve Corporation  
17 Old Carriage Court  
Kitchener, Ontario  
N2P 1V3

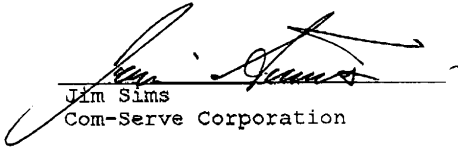
  
Jim Sims  
Com-Serve Corporation

TECHNICIAN:

Jim Sims  
With: Mr. Masud Attayi and Mr. Jonathan Doll (Research in Motion)

FILE NUMBER: RIM 025



|                              |                 |   |
|------------------------------|-----------------|---|
| Author Data<br>Jonathan Doll | August 30, 1999 | Document No.<br>02400-CERT-FCC-TEST-BW_MASK |
| Approved<br>Masud S. Attayi  | Rev             | File / Reference<br>BW Masks                |

### OCCUPIED BANDWIDTH/BANDWIDTH LIMITATIONS

#### TEST PROCEDURE:

The Research In Motion Limited R802D-2-O Radio modem was connected together with a host computer, external power supply and a 20 dB external attenuator. The R802D-2-O antenna output terminal was connected to the input of a 50  $\Omega$  spectrum analyzer through a matched 20 dB attenuator. The R802D-2-O transmitter was operating at full output power with and without internal data modulation.

#### TEST RESULTS:

UNMODULATED CARRIER, High Power: **12.87dBm** with a 20dB external pad and a 1 m Sucoflex cable with a total loss of 0.18 dB.

Internal Modulation: Please refer to the attached spectrum analyzer plots. 100% of the in-band modulation is below the specified mask per 90.210(g) for both RD\_LAP and MDC protocols.

Below is the **description of the mask** for band 806-821/851-866 MHz (DataTAC) : 2.0 Watts transmitter

| <u>Frequency</u><br>(MHz) | <u>Formula</u>                                  | <u>Limit</u><br>(Db) |
|---------------------------|---|----------------------|
| -26500                    | 43+10 log (P)                                   | -46                  |
| -0.050                    | 43+10 log (P)                                   | -46                  |
| -0.050                    | 50+10 log (P)                                   | -53                  |
| -0.0175                   | 116 log ( $f_d / 6.1$ )                         | -53                  |
| -0.010                    | 116 log ( $f_d / 6.1$ ) or 83 log ( $f_d / 5$ ) | -25                  |
| -0.005                    | 83 log ( $f_d / 5$ )                            | 0.0                  |
| 0.005                     | 83 log ( $f_d / 5$ )                            | 0.0                  |
| 0.010                     | 116 log ( $f_d / 6.1$ ) or 83 log ( $f_d / 5$ ) | -25                  |
| 0.0175                    | 116 log ( $f_d / 6.1$ )                         | -53                  |
| 0.050                     | 50+10 log (P)                                   | -53                  |
| 0.050                     | 43+10 log (P)                                   | -46                  |
| 26500                     | 43+10 log (P)                                   | -46                  |

|                         |     |                      |
|-------------------------|-----|----------------------|
| Date<br>August 30, 1999 | Rev | Document<br>BW Masks |
|-------------------------|-----|----------------------|

**EQUIPMENT :**

- H.P. 8563E Spectrum Analyzer 9.0 KHz - 26.5 GHz
- HP6632B DC POWER SUPPLY
- Mini Circuits 20 dB att. # NAT-20 0 Hz - 1.5 GHz

**OCCUPIED BANDWIDTH/BANDWIDTH LIMITATIONS  
 UNMODULATED CARRIER**

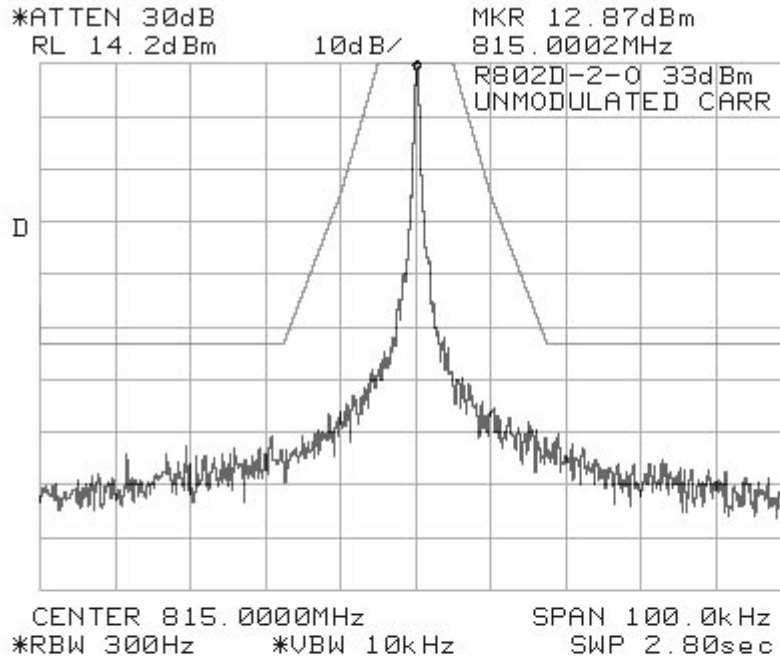

**OCCUPIED BANDWIDTH/BANDWIDTH LIMITATIONS  
 MODULATED CARRIER - RD\_LAP**



Document  
R802D-2-0 RADIO MODEM DEVICE OCCUPIED  
BANDWIDTH/BANDWIDTH LIMITATIONS

|                         |     |                      |
|-------------------------|-----|----------------------|
| Date<br>August 30, 1999 | Rev | Document<br>BW Masks |
|-------------------------|-----|----------------------|

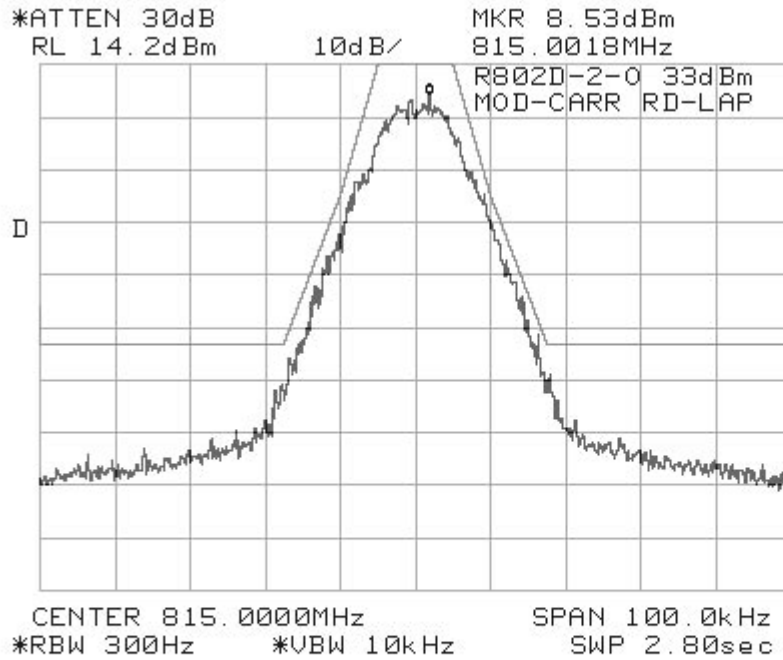



|                         |     |                      |
|-------------------------|-----|----------------------|
| Date<br>August 30, 1999 | Rev | Document<br>BW Masks |
|-------------------------|-----|----------------------|

## OCCUPIED BANDWIDTH/BANDWIDTH LIMITATIONS

### MODULATED CARRIER MDC

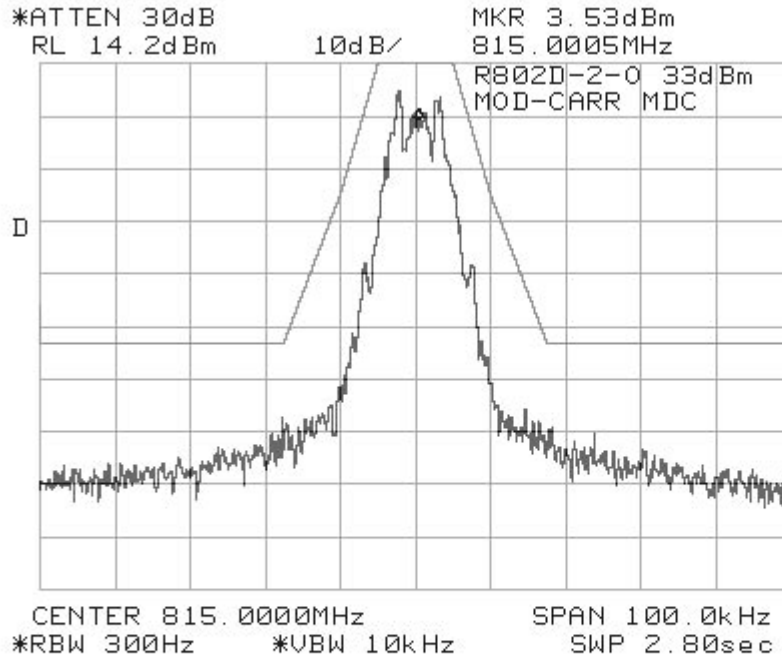



|                              |                 |  |
|------------------------------|-----------------|--|
| Author Data<br>Jonathan Doll | August 30, 1999 | Document No.<br>02400-CERT-FCC-TEST-SPURIOUS |
| Approved<br>Masud S. Attayi  | Rev             | File / Reference<br>Spurious Emissions       |

### SPURIOUS EMISSIONS AT ANTENNA TERMINALS

#### TEST PROCEDURE:

The Research In Motion Limited R802D-2-O radio modem device was connected together with a radio monitor board 02120-001, host computer, external power supply, a 30 dB external attenuator, and a 0.80 dB coaxial cable. The R802D-2-O antenna output terminal was connected to the input of a 50  $\Omega$  spectrum analyzer through a matched 30 dB attenuator and a coaxial cable. The transmitter was operating at full output power with and without internal data modulation. The calculated limit below the unmodulated carrier at +2.50 dBm, including the 30 dB external attenuator and 0.8 dB cable loss, is equal to +33.30 dBm. The actual limit is 46.3 dBc lower, or -13.0 dB.

#### TEST RESULTS:

Ref 815

+33.30 (- 46.3)

-13.0

| FREQUENCY<br>MHz | LEVEL<br>DBm | LIMIT<br>DB |
|------------------|--------------|-------------|
| 815              | +33.30       |             |
| 1630             | -40.87       | -13.00      |
| 2445             | -46.70       | -13.00      |
| 3260             | -57.37       | -13.00      |
| 4075             | -47.70       | -13.00      |
| 4890             | -56.20       | -13.00      |
| 5705             | -57.37       | -13.00      |
| 6520             | NOT FOUND    | -13.00      |
| 7335             | NOT FOUND    | -13.00      |

#### NOTE:

The above limits take into account the unmodulated carrier level of +33.30 dBm inclusive of the 30 dB external attenuator and 0.80 dB coaxial cable loss. The modulation used for spurious harmonics was a worst case, random data pattern while still representing a normal modulation pattern.

#### EQUIPMENT:

- H.P. 8563E Spectrum Analyzer 9.0 KHz - 26.5 GHz
- RIM OEM Interface wth AC adaptor P/N:WR91A2400CCP
- Radio: R802D-2-O
- Mini Circuits 20 dB att. # NAT-20 0 Hz - 10.5 GHz
- MD west microwave att. # 0217NNN-02 10dB DC - 8.0 GHz



|                                     |                        |  |
|-------------------------------------|------------------------|--|
| Author Data<br><b>Jonathan Doll</b> | <b>August 30, 1999</b> | Document No.<br><b>02400-CERT-FCC-TEST-012</b> |
| Approved<br><b>Masud S. Attayi</b>  | Rev                    | File / Reference<br><b>012</b>                 |

CFR 47 Chapter 1 - Federal Communication Commission Rules

Part 2 Required Measurement  
 2.1046 (a,c) RF Power Output

Part 90 Subpart I : Technical Standards  
 90.205 RF Power Output  
 (i) Maximum power output limit : reference to subpart S, Subsection 90.635 (806-821 MHz band).

Part 90 - Subpart S : Use of Frequencies in 806-821 MHz Band  
 90.635 Limitations on Output Power  
 (d) Mobile station maximum output power is 100 W (20dBW)

We are rating the device as 2.00 W (33 dBm) transmitter output power across a 50 ohm load, but due to the 0.5 dB uncertainty in our Calibration Software Tool, we are requesting 2.25 W (33.5 dBm).  
 Limit on device output power would therefore be 2.25 W (33.5 dBm).

Calibrated power measurement using the following equipment:  
 HP EPM-441A Power Meter S/N GB37481294 Cal on 05/08/99  
 HP ECP-E18A Power Sensor S/N US37181260 Cal on 05/08/99  
 HP 8720D Network Analyzer S/N US36140834 Cal on 05/08/99  
 HP HP85033D Calibration Kit S/N 3423A00734 Cal on 05/08/99  
 Mini-Circuits NAT-20 DC to 1500 MHz Coaxial Attenuator

Procedure: These results were obtained using the test procedure described in document 02400-CERT-FCC-TEST-013.

The HP8720D was calibrated using the HP85033D. The cable assembly and microwave attenuator used for the measurements were calibrated using the HP8720D. The EPM-441A and ECP-E18A were calibrated using the internal power reference. The radio was tuned by the procedure as provided for sections 2.1033 (c) (8) and 2.1033 (c) (9). At three transmit frequencies the maximum radio output power level was measured using the EPM-441A and ECP-E18A. Output levels were measured for both modulated and unmodulated carrier. The calibrated insertion loss measured for the attenuator and cable assembly was added to the calibrated power measurements which produced the following results:

Results:

| Carrier Frequency (MHz) | Measured Level (dBm) | Calibrated Attenuation (dB) | Output Power (dBm) | Output Power (W) |
|-------------------------|----------------------|-----------------------------|--------------------|------------------|
| 806.000                 | 12.88                | 20.18                       | 33.06              | 2.023            |
| 815.000                 | 12.87                | 20.18                       | 33.05              | 2.018            |
| 821.000                 | 12.83                | 20.18                       | 33.01              | 2.000            |





|                                     |                        |  |
|-------------------------------------|------------------------|--|
| Author Data<br><b>Jonathan Doll</b> | <b>August 30, 1999</b> | Document No.<br><b>02400-CERT-FCC-TEST-013</b> |
| Approved<br><b>Masud S. Attayi</b>  | Rev                    | File / Reference<br><b>013</b>                 |

CFR 47 Chapter 1 - Federal Communications Commission Rules

Part 2 Required Measurement

- 2.1055 Frequency Stability - Procedures
  - (a,b) Frequency Stability - Temperature Variation
  - (d) Frequency Stability - Voltage Variation

Part 90 Subpart I : Technical Standards

- 90.213 Frequency Tolerance
  - (a) Maintain the carrier frequency within 0.00025 % (2.5 ppm) of the assigned frequency.
  - (b) Maximum power output used for measurement

Frequency and power measurements were performed together with the same set up. Frequency and power data were both recorded across temperature and voltage. The set up used a cable assembly with a power splitter to allow concurrent measurements with the frequency counter, and the power meter. The cable assembly was calibrated to allow compensation of the insertion loss between the transmitter and the power meter.

Calibration for the Cable and Attenuator Loss:

Place: RF Lab in RIM  
 Date: JULY 28th, 1999

Instruments used:

| Instrument                | Serial Number | Calibrated on |
|---------------------------|---------------|---------------|
| Network Analyzer HP 8720D | US36140834    | 05/08/99      |
| Calibration Kit HP85033D  | 3423A00734    | 05/08/99      |

Procedure:

Full Two port Calibration of 8720D using the 85033D was done.

An assembly of Cables, Attenuator, power splitter, and connectors were set up to complete the RF power measurements.

- Attenuator: 20dB, DC to 1500 MHz - Mini-Circuits model no: NAT-20
- Power splitter 3 Port: 4.50 dB - Mini-Circuits model no: MCL ZN3PD- 900W

The total loss of this cable assembly from the RF input to the RF output was measured to be 26.16 dB at 815.0 ± 6 MHz.

|                 |     |   |
|-----------------|-----|---|
| August 30, 1999 | Rev | Document No.<br>02400-CERT-FCC-TEST-013 |
|-----------------|-----|---|

Power and frequency measurements of RIM Radio Modem at different temperatures:

Place: RF Lab in RIM  
 Date: JULY 28th, 1999

Instruments used:

| Instrument                  | Serial number | Calibrated on |
|-----------------------------|---------------|---------------|
| DC Power supply HP 6632B    | US37472173    | 28/07/99      |
| Universal Counter HP 53131A | 3736A18844    | 03/08/99      |
| Power Meter HP EPM-441A     | GB37481300    | 05/08/99      |
| Power Sensor HP ECP-E18A    | US37181260    | 05/08/99      |

Temperature Chamber used:

Manufacturer: Envirotronics  
 Model: SH8C  
 Serial No: 01984093-S-10860

Procedure:

The RIM Radio Modem was placed in the Temperature chamber and connected to the instruments outside as shown in the figure below. Dry air was pumped inside the temperature chamber to maintain a back pressure during the test. The Radio was kept in the off condition at all times except when the measurements were to be made.

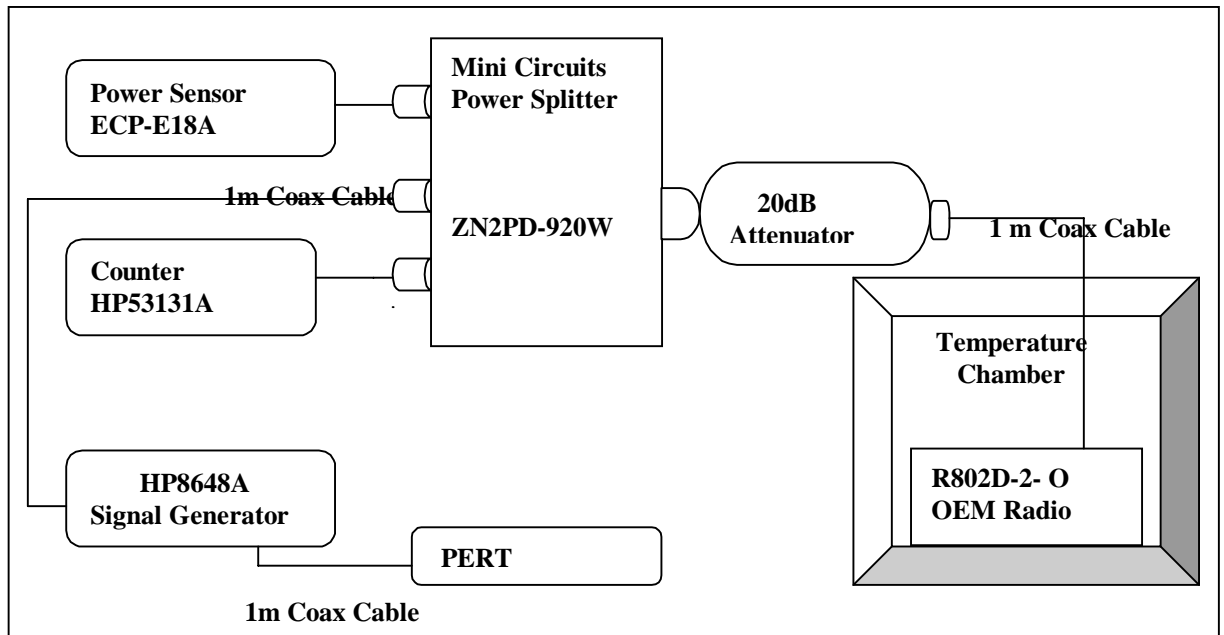

The chamber was switched on and the temperature was set to -30°C.



August 30, 1999

Rev

Document No.

02400-CERT-FCC-TEST-013

After the chamber stabilized at -30 °C there was a soak period of one hour to alleviate moisture in the chamber. The Radio was switched on and frequency and power measurements were made as follows:

The RIM Radio automated test utility was controlled by a computer. This application was given the command of activating all machines intrinsic to the temperature test. It controls the HP 53131A universal counter, HP 6632B power supply, and HP EPM-441A power meter by GPIB Bus. The Environmental Chamber was instructed through an RS-232 serial line. The RIM Radio Modem dialogue was passed through a serial connection from the controlling computer to a Radio Modem Interface. The radio was put in repetitive transmit modes and the power and frequency levels were measured and recorded by the RIM automated test utility.

The RIM Radio Modem Automated test utility produces data files in text format. All data from this test has been formatted from the initial files into a single Spreadsheet.

The RIM Radio Modem output was characterized through its power and frequency across temperature (-30°C to 60°C), and transmit frequency (806 MHz to 821 MHz) at an output power of 33 dBm.

The Radio Modem power and frequency were measured at voltages of 4.15, 4.45 and 4.75 VDC. The transmit frequency was varied in 3 steps consisting of 806 MHz, 815 MHz and 821 MHz. This frequency generated by the RIM Radio Modem has been recorded in MHz and also as deviation from nominal in Parts Per Million.

The output from the RIM Radio Modem was accounted from -30°C to 60°C in +5°C steps. The radio was interrogated for data every 18 seconds for each measurement and 6.0 minutes for each voltage readings. From activity the radio heats up and produces different signals. This heating led to much data which characterizes the radio over most temperatures, not just at 5°C intervals.

After the initial one hour soak, a ½ hour soak was accomplished between the subsequent temperature steps.

## PROCEDURE

This process was affected through automation.

1. Switch on the HP 6632B, power supply and set the Voltage to 4.45 V
2. Set the initial Environmental Chamber temperature (-30 Degrees Celsius) and hold for initial soak.
3. Set the frequency to 806 MHz, and power to 33 dBm on RIM Radio Modem.
4. Activate Carrier on RIM Radio Modem.
5. Take initial HP EPM-441A power meter measurement.
6. Take initial HP 53131A frequency counter measurement.
7. Measure temperature of product.
8. Measure power output.
9. Measure frequency output
10. Increase temperature by 5°C and soak for 1/2 hour. Repeat steps 8 - 10 for twenty measurements every 18 seconds for 6 minutes.
11. Repeat steps 3 - 10 for 815 MHz and 821 MHz.
12. Increase temperature by 5°C and soak for 1/2 hour.



|                 |     |   |
|-----------------|-----|---|
| August 30, 1999 | Rev | Document No.<br>02400-CERT-FCC-TEST-013 |
|-----------------|-----|---|

13 Repeat steps 2-12 for temperatures -30 degrees to 60 degrees Celsius.

Procedure 3 to 12 was then repeated at 25°C with the power supply voltage set to 4.15, 4.45 and 4.75V.



|                                     |                        |  |
|-------------------------------------|------------------------|--|
| Author Data<br><b>Jonathan Doll</b> | <b>August 30, 1999</b> | Document No.<br><b>02400-CERT-FCC-TEST-014</b> |
| Approved<br><b>Masud S. Attayi</b>  | Rev                    | File / Reference<br><b>014</b>                 |

CFR 47 Chapter 1 - Federal Communication Commission Rules

Part 2 Required Measurement

- 2.1055 Frequency Stability - Procedures
- (a,b) Frequency Stability - Temperature Variation

Part 90 - Subpart I : Technical Standards

- 90.213 Frequency Tolerance
- (a) Maintain the carrier frequency within 0.00025 % (2.5 ppm) of the assigned frequency.
- (b) Maximum power output used for measurement

Procedure: These results were obtained using the test procedure described in document 02400 -CERT-FCC-TEST-013.

Results: 806 MHz nominal transmitter

| Ambient Temperature (Degrees Celsius) | Minimum Device Temperature (Degrees Celsius) | Maximum Device Temperature (Degrees Celsius) | Initial Frequency Deviation [ppm] | Maximum Deviation [ppm] |
|---------------------------------------|--|--|-----------------------------------|-------------------------|
| -30                                   | -22.4  | -21.8  | 0.4591                            | 1.3251                  |
| -25                                   | -17.4  | -16.8  | 0.5112                            | 0.5112                  |
| -20                                   | -12.7  | -12  | 0.4218                            | 0.4218                  |
| -15                                   | -7.4   | -6.6   | 0.2767                            | 0.2767                  |
| -10                                   | -2.2   | -1.5   | 0.1427                            | 0.1427                  |
| -5                                    | 3  | 3.5  | 0.0298                            | 0.0347                  |
| 0                                     | 8  | 8.6  | -0.0360                           | 0.8524                  |
| 5                                     | 12.5   | 13.2   | -0.0658                           | 0.8189                  |
| 10                                    | 17.6   | 18.3   | -0.0682                           | -0.0906                 |
| 15                                    | 22.3   | 23.1   | -0.0273                           | -0.0298                 |
| 20                                    | 27.8   | 28.6   | 0.0757                            | 0.0968                  |
| 25                                    | 33.1   | 33.8   | 0.1923                            | 0.2072                  |
| 30                                    | 37.8   | 39.1   | 0.2643                            | 0.2655                  |
| 35                                    | 42.5   | 44.1   | 0.2382                            | 0.2382                  |
| 40                                    | 48.1   | 49.1   | 0.0620                            | 0.0620                  |
| 45                                    | 53   | 54.2   | -0.2060                           | -0.3400                 |
| 50                                    | 58.3   | 59.6   | -0.5546                           | -0.7060                 |
| 55                                    | 63.1   | 64.5   | -0.9094                           | -1.0434                 |
| 60                                    | 67.9   | 69.3   | -1.1849                           | -1.2556                 |

Results: 815 MHz nominal transmitter



|                         |     |   |
|-------------------------|-----|---|
| Date<br>August 30, 1999 | Rev | Document No.<br>02400-CERT-FCC-TEST-014 |
|-------------------------|-----|---|

| Ambient Temperature (Degrees Celsius) | Minimum Device Temperature (Degrees Celsius) | Maximum Device Temperature (Degrees Celsius) | Initial Frequency Deviation [ppm] | Maximum Deviation [ppm] |
|---------------------------------------|--|--|-----------------------------------|-------------------------|
| -30                                   | -22.6  | -22.1  | 0.3988                            | 1.3055                  |
| -25                                   | -17.5  | -16.9  | 0.4761                            | 0.5031                  |
| -20                                   | -12.7  | -12.1  | 0.3693                            | 0.3791                  |
| -15                                   | -7.5   | -7   | 0.2000                            | 1.0847                  |
| -10                                   | -2.4   | -1.9   | 0.0810                            | 0.0969                  |
| -5                                    | 2.7  | 3.3  | -0.0135                           | -0.0135                 |
| 0                                     | 7.7  | 8.3  | -0.0712                           | 0.8147                  |
| 5                                     | 12.2   | 12.8   | -0.1141                           | -0.1153                 |
| 10                                    | 17.5   | 18   | -0.0945                           | -0.1006                 |
| 15                                    | 22.3   | 22.8   | -0.0552                           | -0.0613                 |
| 20                                    | 27.8   | 28.3   | 0.0429                            | 0.9423                  |
| 25                                    | 33   | 33.8   | 0.1558                            | 0.2098                  |
| 30                                    | 37.9   | 38.6   | 0.2221                            | 0.2638                  |
| 35                                    | 42.7   | 43.6   | 0.1963                            | 0.2184                  |
| 40                                    | 47.9   | 48.7   | 0.0160                            | 0.0380                  |
| 45                                    | 53   | 54.1   | -0.2724                           | -0.3092                 |
| 50                                    | 58   | 59.2   | -0.6184                           | -0.6761                 |
| 55                                    | 63.2   | 64.3   | -0.9669                           | -1.0074                 |
| 60                                    | 68.3   | 69.2   | -1.2319                           | -1.2405                 |



|                         |     |   |
|-------------------------|-----|---|
| Date<br>August 30, 1999 | Rev | Document No.<br>02400-CERT-FCC-TEST-014 |
|-------------------------|-----|---|

Results: 821 MHz nominal transmitter

| Ambient Temperature (Degrees Celsius) | Minimum Device Temperature (Degrees Celsius) | Maximum Device Temperature (Degrees Celsius) | Initial Frequency Deviation [ppm] | Maximum Deviation [ppm] |
|---------------------------------------|--|--|-----------------------------------|-------------------------|
| -30                                   | -27.9  | -27.9  | 0.3362                            | 1.1949                  |
| -25                                   | -23  | -22.9  | 0.4641                            | 0.4653                  |
| -20                                   | -18.2  | -18.1  | 0.3995                            | 0.3995                  |
| -15                                   | -13.3  | -13.1  | 0.2521                            | 0.2558                  |
| -10                                   | -8.3   | -8.2   | 0.1242                            | 0.1267                  |
| -5                                    | -3.5   | -3.2   | 0.0037                            | 0.0097                  |
| 0                                     | 1.4  | 1.6  | -0.0633                           | -0.0804                 |
| 5                                     | 6.2  | 6.3  | -0.1084                           | -0.1242                 |
| 10                                    | 11   | 11.1   | -0.1121                           | -0.1303                 |
| 15                                    | 15.9   | 16.1   | -0.0828                           | -0.0901                 |
| 20                                    | 20.9   | 21   | 0.0085                            | 0.9123                  |
| 25                                    | 25.9   | 25.9   | 0.1218                            | 1.0305                  |
| 30                                    | 30.8   | 30.9   | 0.2095                            | 0.2241                  |
| 35                                    | 35.7   | 35.8   | 0.2266                            | 0.2266                  |
| 40                                    | 40.6   | 40.7   | 0.0877                            | 0.0877                  |
| 45                                    | 45.6   | 45.7   | -0.1705                           | -0.2777                 |
| 50                                    | 50.5   | 50.7   | -0.5104                           | -0.6322                 |
| 55                                    | 55.4   | 55.5   | -0.8636                           | -0.9805                 |
| 60                                    | 60.4   | 60.5   | -1.1669                           | -1.2460                 |



|                                     |                                |  |
|-------------------------------------|--------------------------------|--|
| Author Data<br><b>Jonathan Doll</b> | Date<br><b>August 30, 1999</b> | Document No.<br><b>02400-CERT-FCC-TEST-015</b> |
| Approved<br><b>Masud S. Attayi</b>  | Rev                            | File / Reference<br><b>015</b>                 |

CFR 47 Chapter 1 - Federal Communication Commission Rules

Part 2 Required Measurement

- 2.1055 Frequency Stability - Procedures
- (d) Frequency Stability - Voltage Variation

Part 90 Subpart I : Technical Standards

- 90.213 Frequency Tolerance
- (a) Maintain the carrier frequency within 0.00025 % (2.5 ppm) of the assigned frequency.
- (b) Maximum power output used for measurement

Procedure: These results were obtained using the test procedure described in document 02400 -CERT-FCC-TEST-013.

Results: 806 MHz. nominal transmitter.

| Ambient Temperature [Degrees Celsius] | Device Supply Voltage [Volts] | Initial Frequency Deviation [ppm] | Maximum Deviation [ppm] |
|---------------------------------------|-------------------------------|-----------------------------------|-------------------------|
| 25.0                                  | 4.15                          | -0.0186                           | 1.0074                  |
| 25.0                                  | 4.45                          | 0.1923                            | 0.2072                  |
| 25.0                                  | 4.75                          | 0.2035                            | 0.2221                  |

Results: 815 MHz. nominal transmitter.

| Ambient Temperature [Degrees Celsius] | Device Supply Voltage [Volts] | Initial Frequency Deviation [ppm] | Maximum Deviation [ppm] |
|---------------------------------------|-------------------------------|-----------------------------------|-------------------------|
| 25.0                                  | 4.15                          | 0.1902                            | 1.0577                  |
| 25.0                                  | 4.45                          | 0.1558                            | 0.2098                  |
| 25.0                                  | 4.75                          | 0.1975                            | 0.2172                  |

Results: 821 MHz. nominal transmitter.

| Ambient Temperature [Degrees Celsius] | Device Supply Voltage [Volts] | Initial Frequency Deviation [ppm] | Maximum Deviation [ppm] |
|---------------------------------------|-------------------------------|-----------------------------------|-------------------------|
| 25.0                                  | 4.15                          | -0.0572                           | 1.0171                  |
| 25.0                                  | 4.45                          | 0.1218                            | 1.0305                  |
| 25.0                                  | 4.75                          | 0.1291                            | 0.1462                  |





|                                     |                                |  |
|-------------------------------------|--------------------------------|--|
| Author Data<br><b>Jonathan Doll</b> | Date<br><b>August 30, 1999</b> | Document No.<br><b>02400-CERT-FCC-TEST-015</b> |
| Approved<br><b>Masud S. Attayi</b>  | Rev                            | File / Reference<br><b>015</b>                 |

CFR 47 Chapter 1 - Federal Communication Commission Rules

Part 2 Required Measurement

- 2.1055 Frequency Stability - Procedures
- (d) Frequency Stability - Voltage Variation

Part 90 Subpart I : Technical Standards

- 90.213 Frequency Tolerance
- (a) Maintain the carrier frequency within 0.00025 % (2.5 ppm) of the assigned frequency.
- (b) Maximum power output used for measurement

Procedure: These results were obtained using the test procedure described in document 02400 -CERT-FCC-TEST-013.

Results: 806 MHz. nominal transmitter.

| Ambient Temperature [Degrees Celsius] | Device Supply Voltage [Volts] | Initial Frequency Deviation [ppm] | Maximum Deviation [ppm] |
|---------------------------------------|-------------------------------|-----------------------------------|-------------------------|
| 25.0                                  | 4.15                          | -0.0186                           | 1.0074                  |
| 25.0                                  | 4.45                          | 0.1923                            | 0.2072                  |
| 25.0                                  | 4.75                          | 0.2035                            | 0.2221                  |

Results: 815 MHz. nominal transmitter.

| Ambient Temperature [Degrees Celsius] | Device Supply Voltage [Volts] | Initial Frequency Deviation [ppm] | Maximum Deviation [ppm] |
|---------------------------------------|-------------------------------|-----------------------------------|-------------------------|
| 25.0                                  | 4.15                          | 0.1902                            | 1.0577                  |
| 25.0                                  | 4.45                          | 0.1558                            | 0.2098                  |
| 25.0                                  | 4.75                          | 0.1975                            | 0.2172                  |

Results: 821 MHz. nominal transmitter.

| Ambient Temperature [Degrees Celsius] | Device Supply Voltage [Volts] | Initial Frequency Deviation [ppm] | Maximum Deviation [ppm] |
|---------------------------------------|-------------------------------|-----------------------------------|-------------------------|
| 25.0                                  | 4.15                          | -0.0572                           | 1.0171                  |
| 25.0                                  | 4.45                          | 0.1218                            | 1.0305                  |
| 25.0                                  | 4.75                          | 0.1291                            | 0.1462                  |