



849 NW STATE ROAD 45  
NEWBERRY, FL 32669 USA  
PH: 888.472.2424 OR  
352.472.5500  
FAX: 352.472.2030  
EMAIL: [INFO@TIMCOENGR.COM](mailto:INFO@TIMCOENGR.COM)  
[HTTP:// WWW.TIMCOENGR.COM](http://WWW.TIMCOENGR.COM)

**FCC PART 73  
FM BROADCAST STATIONS  
TEST REPORT**

<b>APPLICANT</b>	WORLDCAST SYSTEMS, INC.
	19595 NE 10TH AVENUE SUITE A MIAMI, FL 33179 USA
<b>FCC ID</b>	O35EFM0300W
<b>MODEL NUMBER</b>	EFM0300W
<b>PRODUCT DESCRIPTION</b>	300W FM BROADCAST TRANSMITTER
<b>DATE SAMPLE RECEIVED</b>	7/25/2016
<b>FINAL TEST DATE</b>	8/29/2016
<b>TESTED BY</b>	Cory Leverett
<b>APPROVED BY</b>	Sid Sanders
<b>TEST RESULTS</b>	<input checked="" type="checkbox"/> PASS <input type="checkbox"/> FAIL

Report Number	Version Number	Description	Issue Date
1448AUT16TestReport_	Rev1	Initial Issue	8/30/2016
1448AUT16TestReport_	Rev2	Administrative Updates	11/2/2016

**THE ATTACHED REPORT SHALL NOT BE REPRODUCED EXCEPT IN FULL  
WITHOUT THE WRITTEN APPROVAL OF TIMCO ENGINEERING, INC.**



## TABLE OF CONTENTS

GENERAL REMARKS.....	3
GENERAL INFORMATION.....	4
TEST REPORT SUMMARY.....	5
MODULATION CHARACTERISTICS .....	6
Test Data: Necessary Bandwidth Calculation.....	7
Test Data: Occupied Bandwidth Measurement.....	7
Test data: Audio Frequency Response .....	8
Test data: Modulation Limiting.....	9
RF POWER OUTPUT .....	10
Test Data: Power Output Measurement Table .....	10
OCCUPIED BANDWIDTH.....	11
Test Data: Monaural Operation 15 KHz input .....	12
Test Data: Stereophonic Operation 15 KHz input .....	13
SPURIOUS EMISSIONS AT ANTENNA TERMINALS (CONDUCTED) .....	14
Test Data: High Power Low end of Band .....	15
Test Data: Low Power Low end of Band.....	15
Test Data: High Power Middle of Band.....	16
Test Data: Low Power Middle of Band .....	16
Test Data: High Power High End of Band .....	17
Test Data: low Power High End of Band.....	17
FIELD STRENGTH OF SPURIOUS EMISSIONS.....	18
Test Data: High Power High end of band .....	19
FREQUENCY STABILITY.....	20
Test Data: High Power High end of band .....	20
EQUIPMENT LIST .....	21

## GENERAL REMARKS

The attached report shall not be reproduced except in full without the written permission of Timco Engineering Inc.

### Summary

The device under test does:

- Fulfill the general approval requirements as identified in this test report and was selected by the customer.
- Not fulfill the general approval requirements as identified in this test report

### Attestations

This equipment has been tested in accordance with the standards identified in this test report. To the best of my knowledge and belief, these tests were performed using the measurement procedures described in this report.

All instrumentation and accessories used to test products for compliance to the indicated standards are calibrated regularly in accordance with ISO 17025 requirements.

I attest that the necessary measurements were made at:

**Timco Engineering Inc.**  
**849 NW State Road 45**  
**Newberry, FL 32669**

#### Tested by:



Name and Title: Cory Leverett, Project Manager/Testing Technician

**Date: 8/ 30/ 2016**

#### Reviewed and approved by:



Name and Title: Sid Sanders, Engineer

**Date: 9/ 28/ 16**

## GENERAL INFORMATION

### EUT Specification

<b>EUT Description</b>	300W FM BROADCAST TRANSMITTER
<b>FCC ID</b>	O35EFM0300W
<b>Model Number</b>	EFM0300W
<b>Operating Frequency</b>	88-108 MHz
<b>Test Frequencies</b>	88.1, 98.0, 106.9 MHz
<b>Type of Emission</b>	180K0F3E
<b>Modulation</b>	FM
<b>Output Power</b>	High Power 300 Watts Low Power 10 Watts
<b>EUT Power Source</b>	<input checked="" type="checkbox"/> 100–240Vac/ 50– 60Hz
	<input type="checkbox"/> DC Power 12V
	<input type="checkbox"/> Battery Operated Exclusively
<b>Test Item</b>	<input type="checkbox"/> Prototype
	<input checked="" type="checkbox"/> Pre-Production
	<input type="checkbox"/> Production
<b>Type of Equipment</b>	<input checked="" type="checkbox"/> Fixed
	<input type="checkbox"/> Mobile
	<input type="checkbox"/> Portable
<b>Test Conditions</b>	The temperature was 26°C with a relative humidity of 50%.
<b>Revision History to the EUT</b>	None
<b>Test Exercise</b>	The EUT was placed in continuous transmit mode.
<b>Applicable Standards</b>	CFR Title 47 Part 2, Part 73 TIA-603-D
<b>Test Facility</b>	<b>Timco Engineering Inc.</b> <b>849 NW State Road 45</b> <b>Newberry, FL 32669 USA.</b>

## TEST REPORT SUMMARY

Rule Part No.	Scope of Work	Status Pass/ Fail/ NA
2.1046(a)(c), 73.1560(b)	RF Power Output	Pass
2.202(b)(c)(e)(g), 2.1047(d), 73.1570 (a)(b)(2)	Modulation Characteristics	Pass
2.202(a), 2.1049(e), 73.317(a)(b)(c)(e)	Emission Mask and Occupied Bandwidths	Pass
2.1051, 2.1057, 73.317(a)(d)(e)	Antenna Conducted Emissions	Pass
2.1053, 2.1057, 73.317(a)(d)(e)	Field Strength Spurious Emissions	Pass
2.1055(a)(3)(b)(d)(1)(3), 73.1545(b)	Frequency Stability	Pass

## MODULATION CHARACTERISTICS

**Rule Part No.:** 73.1570(a)(b)(2)

**Requirements:** (a) The percentage of modulation is to be maintained at as high a level as is consistent with good quality of transmission and good broadcast service, with maximum levels not to exceed the values specified in paragraph (b). Generally, the modulation should not be less than 85% on peaks of frequent recurrence, but where lower modulation levels may be required to avoid objectionable loudness or to maintain the dynamic range of the program material, the degree of modulation may be reduced to whatever level is necessary for this purpose, even though under such circumstances, the level may be substantially less than that which produces peaks of frequent recurrence at a level of 85%.

(b) Maximum modulation levels must meet the following limitations:

(2) FM stations. The total modulation must not exceed 100 percent on peaks of frequent reoccurrence referenced to 75 kHz deviation. However, stations providing subsidiary communications services using subcarriers under provisions of §73.319 concurrently with the broadcasting of stereophonic or monophonic programs may increase the peak modulation deviation as follows:

(i) The total peak modulation may be increased 0.5 percent for each 1.0 percent subcarrier injection modulation.

(ii) In no event may the modulation of the carrier exceed 110 percent (82.5 kHz peak deviation).

**Procedure:** 2.202(b)(c)(e)(g), 2.202(b)(c)(e)(g), 2.1047(d), & TIA-603

**Diagram:**

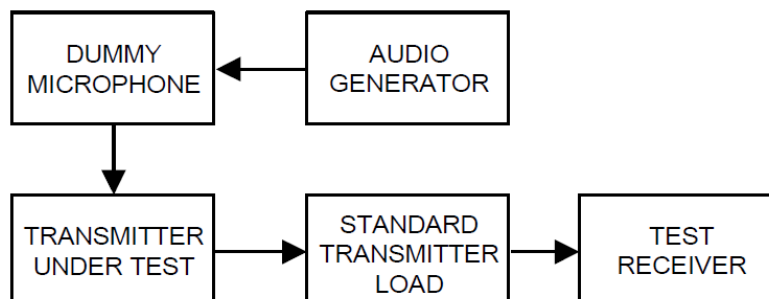

## MODULATION CHARACTERISTICS

Sound Broadcasting			
Sound broadcasting	$B_n = 2M + 2DK$ , K = 1 (typically)	Monaural, D = 75,000 Hz, M = 15,000, Bandwidth: 18,000 Hz = 180 kHz	180KF3E

### Test Data: Necessary Bandwidth Calculation

$$B_n = 2M + 2DK$$

$$M = 15 \text{ KHz}$$

$$D = 75 \text{ KHz}$$

$$K = 1$$

$$B_n = 2(15\text{KHz}) + 2(75\text{KHz}) = 180.0 \text{ KHz}$$

### Test Data: Occupied Bandwidth Measurement

Tuned Frequency (MHz)	99% Occupied Bandwidth (KHz)
88.1	150.0
98.0	150.0
106.9	150.0

**Result: PASS**

# MODULATION CHARACTERISTICS

Test data: Audio Frequency Response

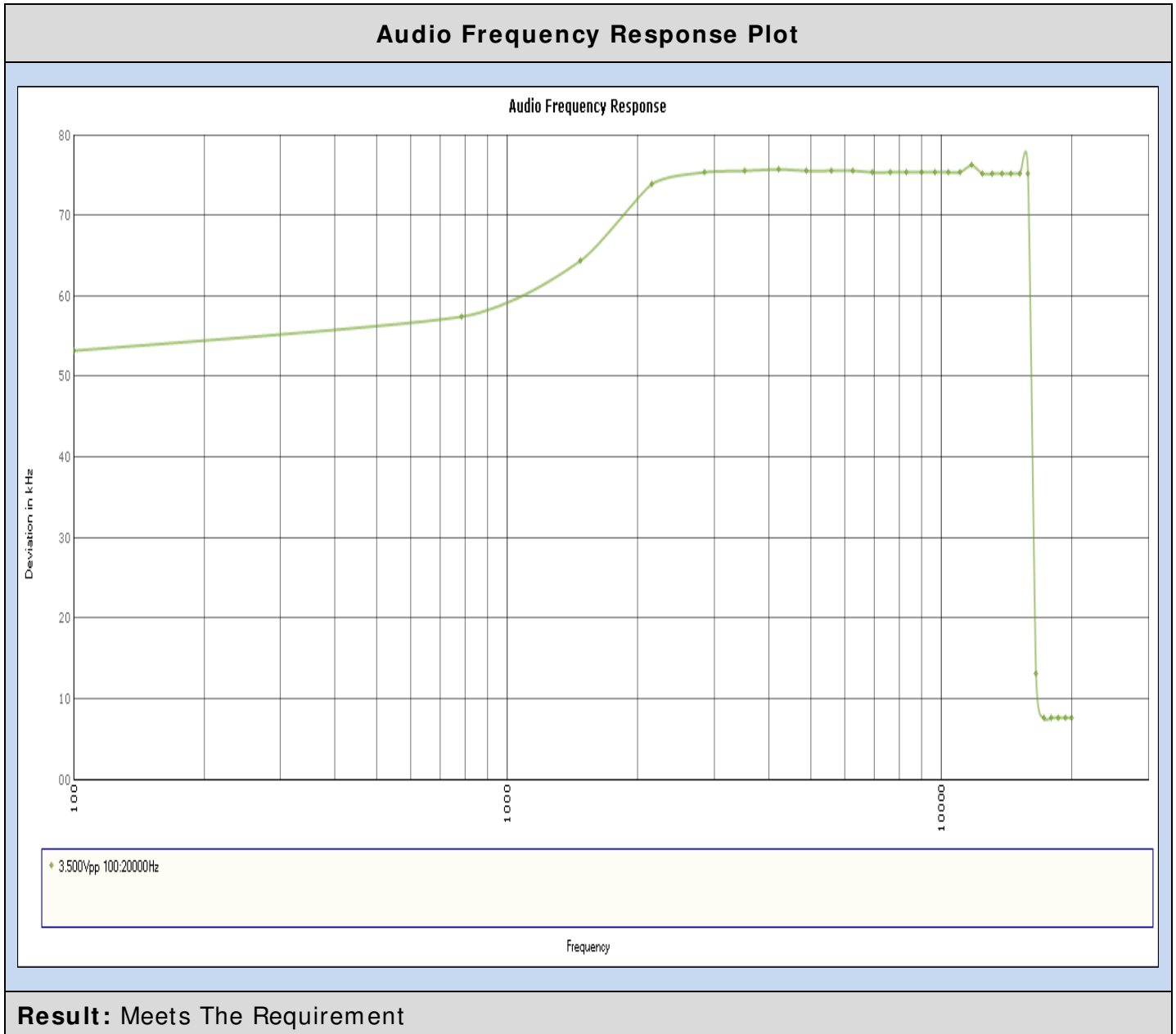

# MODULATION CHARACTERISTICS

Test data: Modulation Limiting

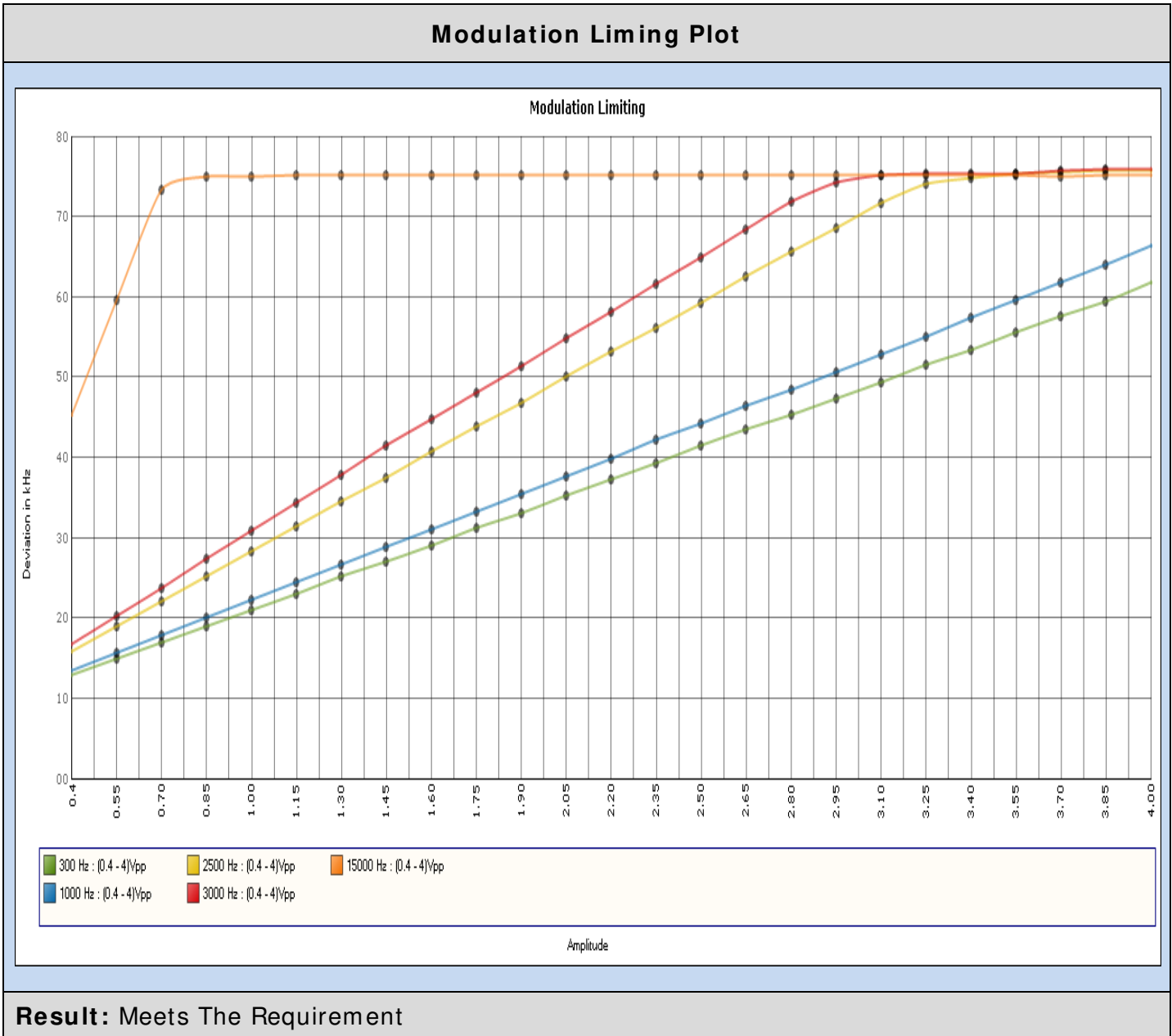

## RF POWER OUTPUT

**Rule Part No.:** 73.1560(b)

**Requirements:** FM stations. Except as provided in paragraph (d) of this section, the transmitter output power of an FM station, with power output as determined by the procedures specified in §73.267, which is authorized for output power more than 10 watts must be maintained as near as practicable to the authorized transmitter output power and may not be less than 90% nor more than 105% of the authorized power. FM stations operating with authorized transmitter output power of 10 watts or less, may operate at less than the authorized power, but not more than 105% of the authorized power.

**Procedure:** FCC Rule Part 2.1046(a)(c), 73.267(b), & TIA-603

**Diagram:**

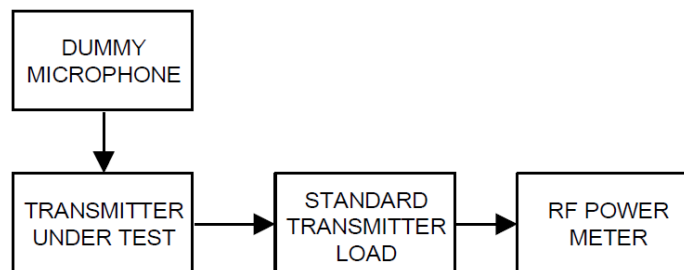

**Test Data: Power Output Measurement Table**

Measured Power Output							
Tuned Freq. MHz	Input Voltage VAC	High			Low		
		dBm	Watts	% Rated Power	dBm	Watts	% Rated Power
88.1	120.0	54.82	303.4	101%	39.97	9.9	99%
98.0	120.0	54.91	309.7	103%	40.11	10.3	103%
106.9	120.0	54.78	300.6	100%	39.86	9.7	97%
<b>Rated Output Power</b>		<b>54.77</b>	<b>300</b>	<b>100</b>	<b>40</b>	<b>10</b>	<b>100</b>
<b>Output Power Limit</b>		<b>90% &lt; Rated Output Power &lt; 105%</b>					

**Result: PASS**

## OCCUPIED BANDWIDTH

**Rule Part No.:** 73.317 (a)(b)(c)(e)

**Requirements:** (a) FM broadcast stations employing transmitters authorized after January 1, 1960, must maintain the bandwidth occupied by their emissions in accordance with the specification detailed below. FM broadcast stations employing transmitters installed or type accepted before January 1, 1960, must achieve the highest degree of compliance with these specifications practicable with their existing equipment. In either case, should harmful interference to other authorized stations occur, the licensee shall correct the problem promptly or cease operation.

(b) Any emission appearing on a frequency removed from the carrier by between 120 kHz and 240 kHz inclusive must be attenuated at least 25 dB below the level of the unmodulated carrier. Compliance with this requirement will be deemed to show the occupied bandwidth to be 240 kHz or less.

(c) Any emission appearing on a frequency removed from the carrier by more than 240 kHz and up to and including 600 kHz must be attenuated at least 35 dB below the level of the unmodulated carrier.

(e) Preemphasis shall not be greater than the impedance-frequency characteristics of a series inductance resistance network having a time constant of 75 microseconds. (See upper curve of Figure 2 of §73.333.)

**Procedure:** FCC Rule Part 2.202(a), 2.1049(e), & TIA-603

### Test Setup Diagram:

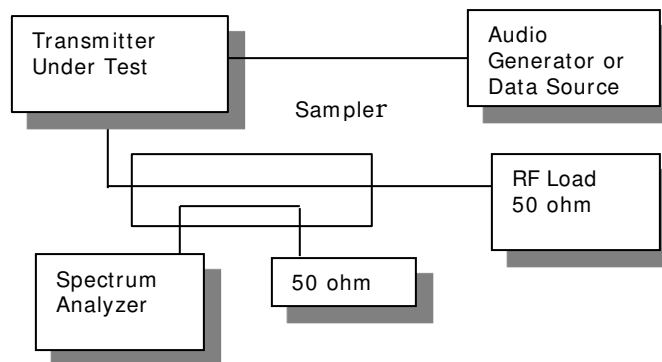

### Note:

Applicant: WORLDCAST SYSTEMS, INC.  
 FCC ID: O35EFM0300W  
 Report: 1448AUT16TestReport\_Rev1.pdf

[Table of Contents](#)

# OCCUPIED BANDWIDTH

Test Data: Monaural Operation 15 KHz input

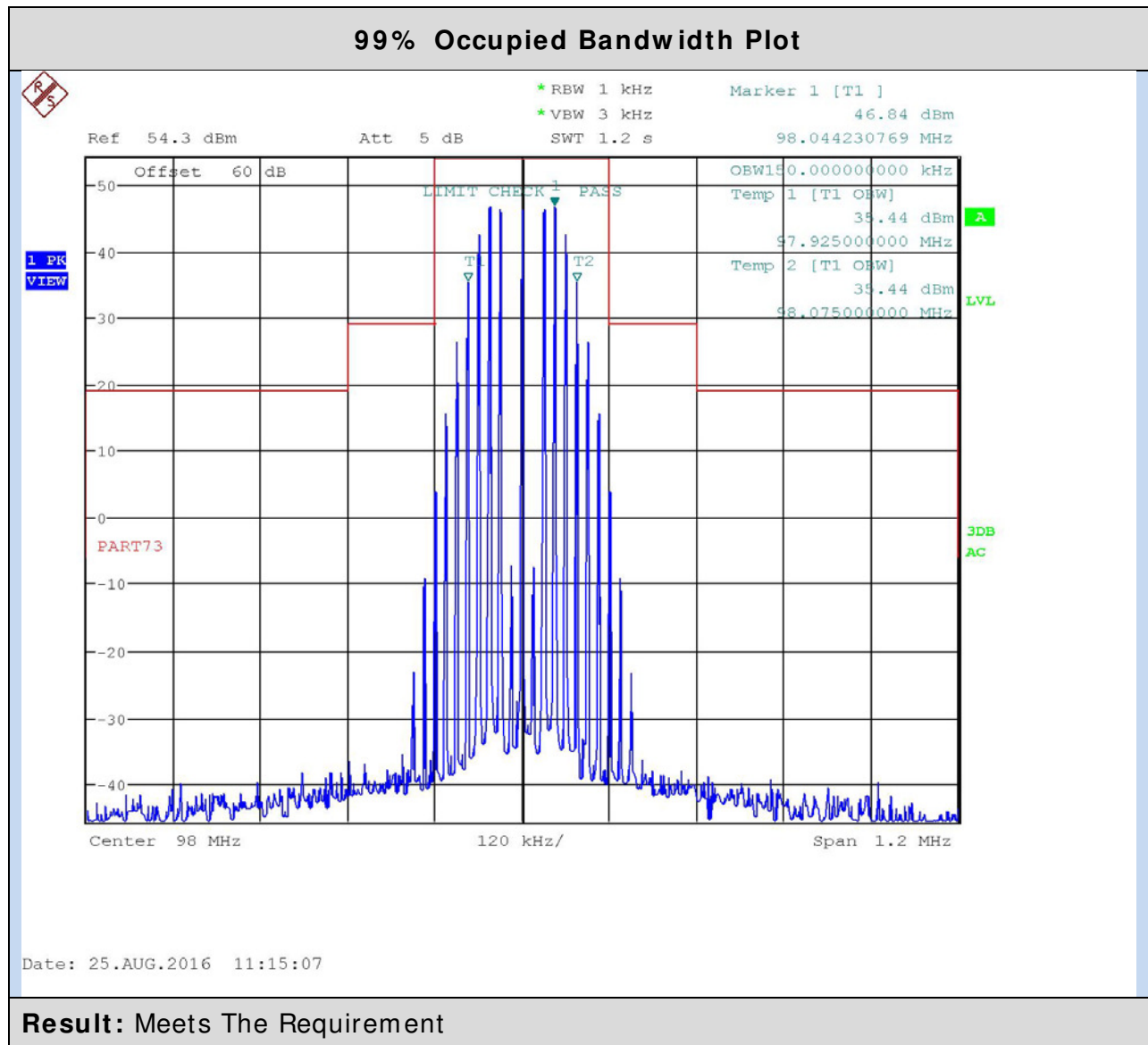

# OCCUPIED BANDWIDTH

Test Data: Stereophonic Operation 15 KHz input

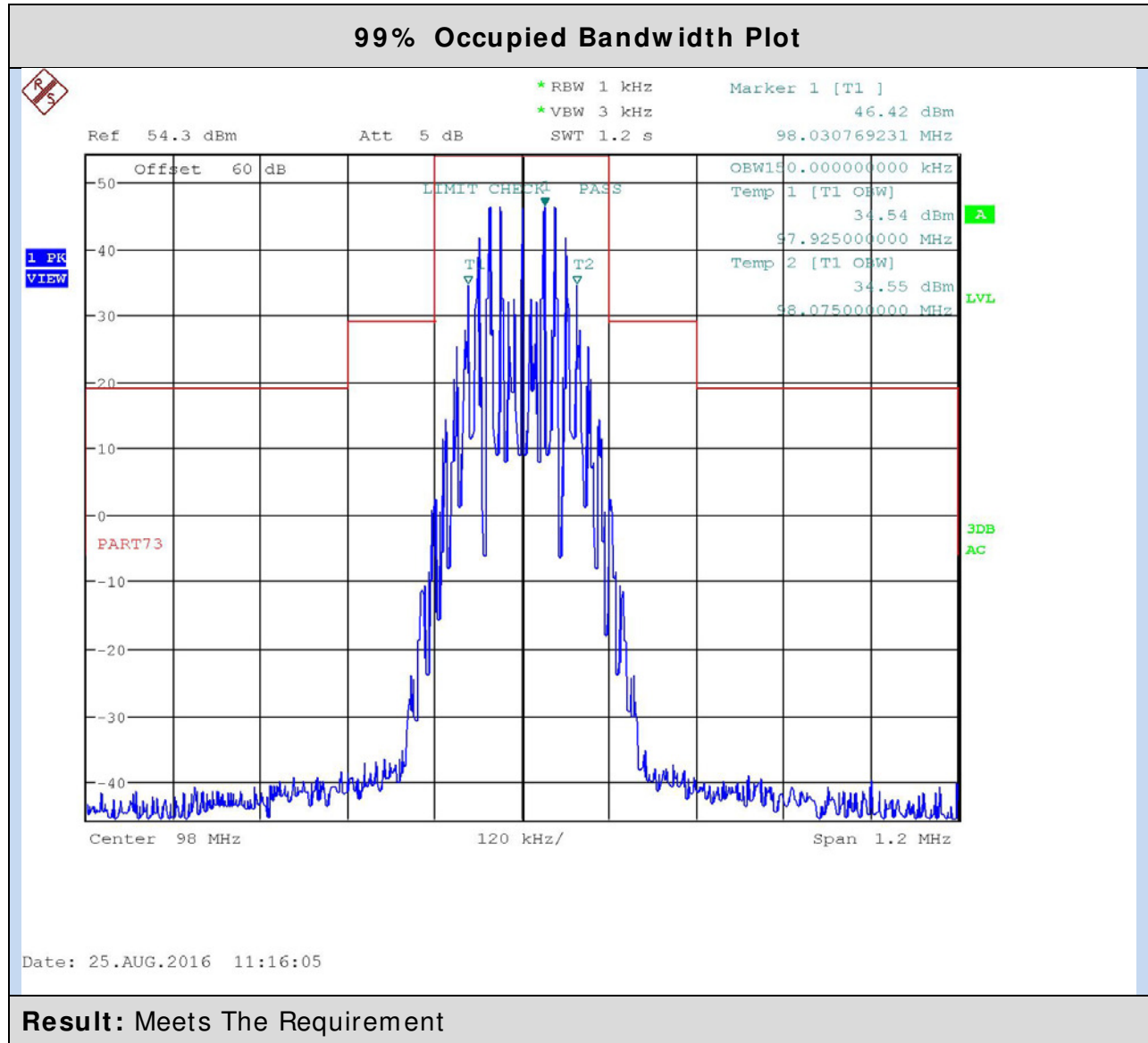

## SPURIOUS EMISSIONS AT ANTENNA TERMINALS ( CONDUCTED)

**Rule Part No.:** 73.317(a)(b)(e)

**Requirements:** (a) FM broadcast stations employing transmitters authorized after January 1, 1960, must maintain the bandwidth occupied by their emissions in accordance with the specification detailed below. FM broadcast stations employing transmitters installed or type accepted before January 1, 1960, must achieve the highest degree of compliance with these specifications practicable with their existing equipment. In either case, should harmful interference to other authorized stations occur, the licensee shall correct the problem promptly or cease operation.

(d) Any emission appearing on a frequency removed from the carrier by more than 600 kHz must be attenuated at least  $43 + 10 \text{ Log}_{10} (\text{Power, in watts})$  dB below the level of the unmodulated carrier, or 80 dB, whichever is the lesser attenuation.

(e) Preemphasis shall not be greater than the impedance-frequency characteristics of a series inductance resistance network having a time constant of 75 microseconds. (See upper curve of Figure 2 of §73.333.)

**Procedure:** FCC Rule Part 2.1051, 2.1057, & TIA-603

**Diagram:**

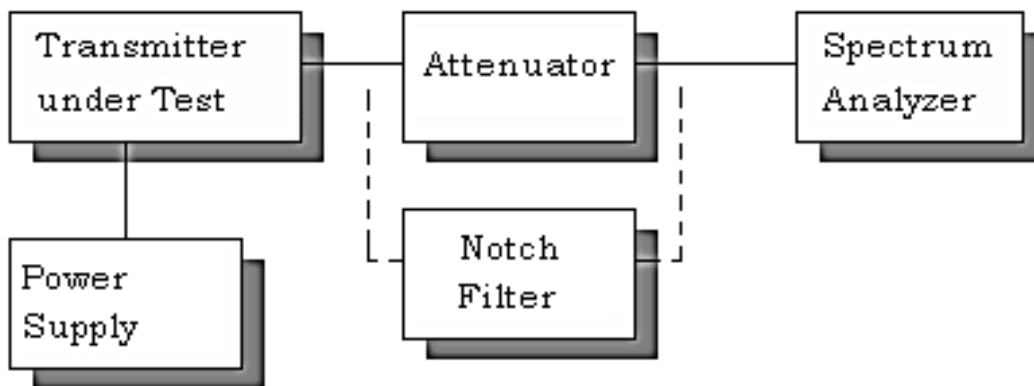

## SPURIOUS EMISSIONS AT ANTENNA TERMINALS (CONDUCTED)

**Note:** All modes of modulation were tested; the Results shown are for the worst case modulation

### Test Data: High Power Low end of Band

	dBm	Watts	Limit dB
Power Output	54.82	303.39	67.82
	Frequency MHz	dBc	Margin dB
	88.1	0	0.0
	176.20	82.7	14.9
	264.30	80.6	12.8
	352.40	97.0	29.2
	440.50	95.3	27.5
*	528.60	101.8	34.0
	616.70	92.3	24.5
*	704.80	100.6	32.8
*	792.90	100.5	32.7
*	881.00	100.7	32.9

\* Indicates Noise Floor

### Test Data: Low Power Low end of Band

	dBm	Watts	Limit dB
Power Output	39.97	9.93	52.97
	Frequency MHz	dBc	Margin dB
	88.1	0	0.0
	176.20	58.8	5.8
*	264.30	74.9	21.9
*	352.40	74.5	21.5
*	440.50	74.5	21.5
*	528.60	74.3	21.3
	616.70	70.2	17.3
*	704.80	74.6	21.6
*	792.90	74.5	21.5
*	881.00	74.7	21.7

\* Indicates Noise Floor

## SPURIOUS EMISSIONS AT ANTENNA TERMINALS ( CONDUCTED)

### Test Data: High Power Middle of Band

	dBm	Watts	Limit dB
Power Output	54.91	309.74	67.91
	Frequency MHz	dBc	Margin dB
	98	0	0.0
	196.00	88.7	20.8
	294.00	84.4	16.5
*	392.00	100.6	32.7
	490.00	91.0	23.1
*	588.00	100.5	32.6
	686.00	95.3	27.4
*	784.00	100.5	32.6
	882.00	95.3	27.3
*	980.00	100.9	33.0

\* Indicates Noise Floor

### Test Data: Low Power Middle of Band

	dBm	Watts	Limit dB
Power Output	40.11	10.26	53.11
	Frequency MHz	dBc	Margin dB
	98	0	0.0
	196.00	70.3	17.2
*	294.00	71.1	17.9
*	392.00	72.3	19.2
*	490.00	72.1	19.0
*	588.00	72.2	19.1
*	686.00	72.1	19.0
*	784.00	72.2	19.1
*	882.00	72.4	19.3
*	980.00	72.6	19.5

\* Indicates Noise Floor

## SPURIOUS EMISSIONS AT ANTENNA TERMINALS ( CONDUCTED)

### Test Data: High Power High End of Band

	dBm	Watts	Limit dB
Power Output	54.78	300.61	67.78
	Frequency MHz	dBc	Margin dB
	106.9	0	0.0
	213.80	81.3	13.5
	320.70	85.1	17.3
	427.60	97.5	29.7
	534.50	92.0	24.2
*	641.40	100.5	32.7
	748.30	96.9	29.1
	855.20	98.3	30.5
	962.10	101.4	33.6
	1069.00	98.8	31.0

\* Indicates Noise Floor

### Test Data: low Power High End of Band

	dBm	Watts	Limit dB
Power Output	39.86	9.68	52.86
	Frequency MHz	dBc	Margin dB
	106.9	0	0.0
	213.80	68.1	15.3
	320.70	72.6	19.7
*	427.60	75.2	22.4
*	534.50	72.7	19.8
*	641.40	74.3	21.4
*	748.30	73.8	20.9
*	855.20	73.4	20.5
*	962.10	74.6	21.7
*	1069.00	76.2	23.3

\* Indicates Noise Floor

**RESULTS: PASS**

## FIELD STRENGTH OF SPURIOUS EMISSIONS

**Rule Part No.:** 73.317(a)(b)(e)

**Requirements:** (a) FM broadcast stations employing transmitters authorized after January 1, 1960, must maintain the bandwidth occupied by their emissions in accordance with the specification detailed below. FM broadcast stations employing transmitters installed or type accepted before January 1, 1960, must achieve the highest degree of compliance with these specifications practicable with their existing equipment. In either case, should harmful interference to other authorized stations occur, the licensee shall correct the problem promptly or cease operation.

(d) Any emission appearing on a frequency removed from the carrier by more than 600 kHz must be attenuated at least  $43 + 10 \text{ Log}_{10} (\text{Power, in watts})$  dB below the level of the unmodulated carrier, or 80 dB, whichever is the lesser attenuation.

(e) Preemphasis shall not be greater than the impedance-frequency characteristics of a series inductance resistance network having a time constant of 75 microseconds. (See upper curve of Figure 2 of §73.333.)

**Procedure:** FCC Rule Part 2.1053, 2.1057, & TIA-603

**Diagram:**

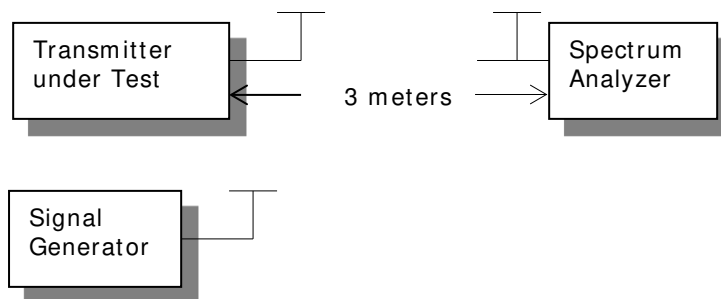

**Note:** The following results are from the worst case modulation for all modes of operation and all of the test frequencies.

## FIELD STRENGTH OF SPURIOUS EMISSIONS

Test Data: High Power High end of band

Emission Frequency (MHz)	Power Mode	ERP Power Output (dBm)	ERP Power Output (Watts)	FCC Requirement dB	Bandwidth - BW - kHz
106.90	Hi	54.78	300.61	67.78	25.00
Emission Frequency (MHz)	Ant. Polarity		Below Carrier (dBc)	Margin dB	
213.80	H		78.82	8.82	
320.70	V		92.25	22.25	
427.60	V		102.11	32.11	
534.50	H		108.61	38.61	
641.40	V		104.82	34.82	
748.30	V		102.56	32.56	
855.20	H		95.48	25.48	
962.10	H		92.77	22.77	
1,069.00	H		83.24	13.24	

Result: PASS

## FREQUENCY STABILITY

**Rule Part No.:** 73.1545(b)

**Requirements:** The departure of the carrier or center frequency of an FM station with an authorized transmitter output power more than 10 watts may not exceed  $\pm 2000$  Hz from the assigned frequency.

**Procedure:** FCC Rule Part 2.1055(a)(3)(b)(d)(1)(3), & TIA/603

### Test Data: High Power High end of band

Temperature	Frequency Hz	PPM
Assigned	106900000	
25°C (reference)	106900019	0.000
0°C	106899995	0.225
10°C	106900012	0.065
20°C	106900001	0.168
30°C	106899998	0.196
40°C	106899970	0.458
50°C	106899976	0.402
Input Voltage	Frequency	PPM
102.00	106900017	0.019
120.00	106900019	0.000
138.00	106900016	0.028

**Result: PASS**



## EQUIPMENT LIST

Device	Manufacturer	Model	Serial Number	Cal/ Char Date	Due Date
Antenna: Biconical 1096 Chamber	Eaton	94455-1	1096	07/14/15	07/14/17
Antenna: Log-Periodic 1122	Electro-Metrics	LPA-25	1122	07/14/15	07/14/17
Temperature Chamber LARGE	Tenney Engineering	TTRC	11717-7	08/19/14	08/19/16
AC Voltmeter	HP	400FL	2213A14499	07/01/15	07/01/17
Digital Multimeter	Fluke	FLUKE-77-3	79510405	10/21/15	10/21/17
Frequency Counter	HP	5385A	2730A03025	10/21/15	10/21/17
CHAMBER	Panashield	3M	N/A	04/25/16	12/31/17
Antenna: Double-Ridged Horn/ETS Horn 2	ETS-Lindgren Chamber	3117	00041534	02/25/15	02/25/17
Software: Field Strength Program	Timco	N/A	Version 4.0	12/12/99	12/12/99
Antenna: Active Loop	ETS-Lindgren	6502	00062529	11/18/15	11/18/17
Coaxial Cable # 100 - NMNM-0180-00 Aqua	Micro-Coax	UFB311A-0-0720-50U50U	225362-001 (# 100)	07/14/16	07/14/18
Coaxial Cable # 101 - NMNM-0180-01 Aqua DC-40G	Micro-Coax	UFB311A-0-0720-50U50U	225362-002 (# 101)	07/18/16	07/18/18
Hygro-Thermometer	Extech	445703	0602	06/30/15	06/30/17
Modulation Analyzer	HP	8901A	3050A05856	04/16/15	04/16/17
EMI Test Receiver R & S ESU 40 Chamber	Rohde & Schwarz	ESU 40	100320	04/01/16	04/01/18
Signal Generator HP 8648C	HP	8648C	3623A02898	02/08/16	02/08/18
Attenuator 30dB 500W	Bird	8325	1761 (# 67) NO	05/18/15	05/18/17
Coaxial Cable - Chamber 3 cable set (Primary)	Micro-Coax	Chamber 3 cable set (Primary)	KMKM-0244-01; KMKM-0670-00; KFKF-0198-01	08/08/16	08/08/18
Function Generator	Standford	DS340	25200	02/02/16	02/02/18
Attenuator N 20dB 50W DC-8.5G	Weinschel Eng	24-20-43	BG5562	05/22/15	05/22/17
Tunable Notch Filter 54-210 MHz	Eagle	210BFBF	54-210 MHz (# 42)	09/17/15	09/17/17

### \* EMI RECEIVER SOFTWARE VERSION

The receiver firmware used was version 4.43 Service Pack 3

### END OF REPORT

Applicant: WORLDCAST SYSTEMS, INC.  
 FCC ID: O35EFM0300W  
 Report: 1448AUT16TestReport\_Rev1.pdf

[Table of Contents](#)

Page 21 of 21

## TEST SETUP PHOTOGRAPHS

APPLICANT: WORLDCAST SYSTEMS, INC.

FCC ID: O35EFM0300W

MODULATION CHARACTERISTICS/ OUTPUT POWER/ OCC BW/ ANT  
CONDUCTED EMISSIONS



**FIELD STRENGTH SPURIOUS EMISSIONS PHOTO 1**

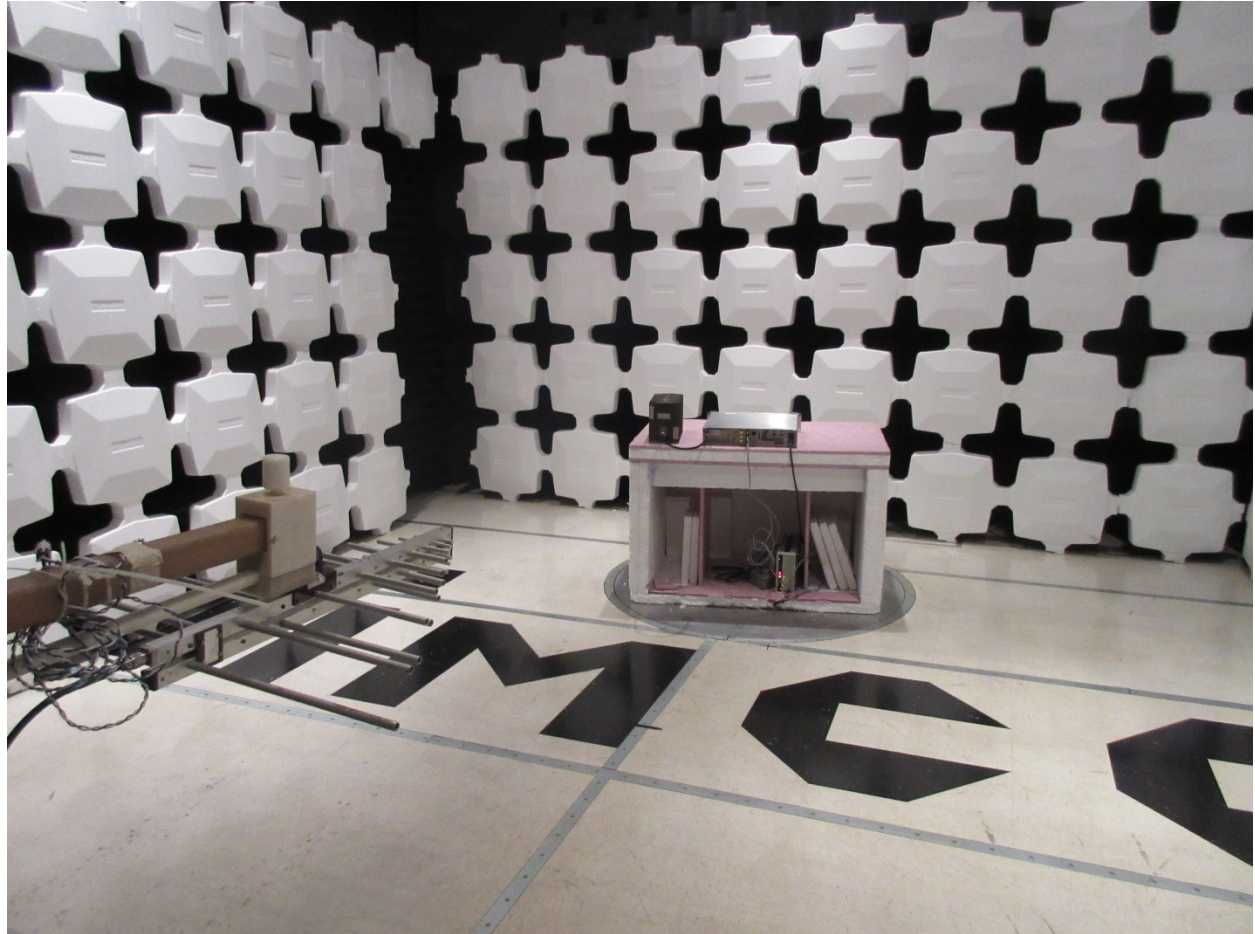

**FIELD STRENGTH SPURIOUS EMISSIONS PHOTO 2**



**FREQUENCY STABILITY**

