



NFC (Near Field Communications)

FCC/IC Test Report

FOR:

Intel Corporation

Model Number: DZ110

**Product Description: Smartphone with GSM/GPRS/EDGE, UMTS/HSPA+/LTE,
Wi-Fi, BT, NFC and GPS Radios**

**47 CFR Part 15 Subpart C Section 15.225
RSS-210 Issue 8, Annex 2, Section 6, RSS-Gen Issue 3**

TEST REPORT #: EMC_INTEL_039_14001_FCC15.225_NFC_rev1

DATE: 2014-06-03



**FCC listed
A2LA Accredited**

**IC recognized #
3462B**

CETECOM Inc.

411 Dixon Landing Road ♦ Milpitas, CA 95035 ♦ U.S.A.

Phone: +1 (408) 586 6200 ♦ Fax: +1 (408) 586 6299 ♦ E-mail: info@cetecomusa.com ♦ <http://www.cetecom.com>

CETECOM Inc. is a Delaware Corporation with Corporation number: 2905571

TABLE OF CONTENTS

1	<i>Assessment</i>	4
2	<i>Administrative Data</i>	5
2.1	Identification of the Testing Laboratory Issuing the Test Report	5
2.2	Identification of the Client	5
2.3	Identification of the Manufacturer	5
2.4	Environmental conditions during Test:	5
3	<i>Equipment under Test (EUT)</i>	6
3.1	Specification of the Equipment under Test	6
3.2	Identification of the Equipment under Test (EUT)	7
3.3	Identification of Accessory equipment	7
4	<i>Subject of Investigation</i>	8
4.1	Dates of Testing:	8
5	<i>Summary of Measurement Results</i>	9
6	<i>In-band Field Strength (Fundamental)</i>	10
6.1	References	10
6.2	Limits	10
6.3	Test Conditions	10
6.4	Radiated Measurement Procedure	11
6.5	Measurement Settings	11
6.6	Measurement Uncertainty	11
6.7	Sample calculation	12
6.8	Test Data Results	13
6.9	Measurement Verdict	13
6.10	Measurement Plots	14
7	<i>Transmitter Spurious Emissions – Radiated</i>	17
7.1	Limits	17
7.2	Measurement Settings	17
7.3	Test Conditions	17
7.4	Radiated test procedure for transmitter spurious emissions:	18
7.5	Measurement Uncertainty	18
7.6	Test Data	19
7.7	Measurement Verdict	19

7.8	Measurement Plots	20
8	<i>Frequency Tolerance</i>	22
8.1	References	22
8.2	Limits	22
8.3	Test Conditions	22
8.4	Test Data	22
8.5	Measurement Verdict	22
9	<i>Occupied Bandwidth</i>	23
9.1	References	23
9.2	Limits	23
9.3	Measurement Settings	23
9.4	Test Data	23
9.5	Measurement Plots	24
10	<i>Test Equipment</i>	27
11	<i>Test Setup Diagrams</i>	28
12	<i>Revision History</i>	29

1 Assessment

The following device was evaluated against the applicable criteria specified in FCC rules Parts 15.225 of Title 47 of the Code of Federal Regulations and Industry Canada Standards RSS-210 Issue 8, Annex 2 and no deviations were ascertained during the course of the tests performed.

Company	Description	Model #
Intel Corporation	Smartphone with GSM/GPRS/EDGE, UMTS/HSPA+/LTE, Wi-Fi, BT, NFC and GPS Radios	DZ110

This report is reviewed by:

2014-06-03	Compliance	Franz Engert (Compliance Manager)	 <small>Digitally signed by Franz Engert DN: cn=Franz Engert, o=US, ou=CETECOM, email=franz.engert@cetecom.com Date: 2014.07.02 19:57:24 -07'00'</small>
Date	Section	Name	Signature

Responsible for the Report:

2014-06-03	Compliance	Danh Le (EMC Engineer)	
Date	Section	Name	Signature

The test results of this test report relate exclusively to the test item specified in Section 3. CETECOM Inc. USA does not assume responsibility for any conclusions and generalizations drawn from the test results with regard to other specimens or samples of the type of the equipment represented by the test item. The test report may only be reproduced or published in full. Reproduction or publication of extracts from the report requires the prior written approval of the CETECOM Inc USA.

2 Administrative Data

2.1 Identification of the Testing Laboratory Issuing the Test Report

Company Name:	CETECOM Inc.
Department:	Compliance
Address:	411 Dixon Landing Road Milpitas, CA 95035 U.S.A.
Telephone:	+1 (408) 586 6200
Fax:	+1 (408) 586 6299
Compliance Manager:	Franz Engert
Responsible Project Leader:	Danh Le

2.2 Identification of the Client

Applicant's Name:	Intel Corporation	
Street Address:	2200 Mission College Blvd	
City/Zip Code	Santa Clara / 95054	
Country	USA	
Contact Person:	Christine Ryan	
Phone No.:	408 300 2167	
Fax No.:	408-765-2336	
e-mail:	Christine.m.ryan@intel.com	

2.3 Identification of the Manufacturer

Manufacturer's Name:	Same as Client
Manufacturers Address:	
City/Zip Code:	
Country:	

2.4 Environmental conditions during Test:

The following environmental conditions were maintained during the course of testing:

Ambient Temperature: 20 - 25°C

Relative humidity: 40-60%

3 Equipment under Test (EUT)

3.1 Specification of the Equipment under Test

Marketing Name / Model No:	Intel 4.5-inch Premium LTE Smartphone / DZ110
Product Type:	NFC (Near Field Communications) / Type A, B & F
FCC-ID :	O2Z-DZ110
IC-ID:	1000W- DZ110
Operating Frequency:	13.56 MHz
Type(s) of Modulation:	ASK (Amplitude Shift Keying)
Data Rate:	Type A and B = approximate 106 kbps & 212 kbps Type F = approximate 212 kbps & 424 kbps
Number of channels:	1
Antenna Info:	Magnetic Loop antenna
Rated Operating Voltage Range (DC):	Internal Battery Operated 3.6V (Low) / 3.8V (Nominal) / 4.2V (Max)
Operating Temperature Range:	-10°C to +55°C
Test Sample status:	Prototype
Other Radios included in the device:	<p>Intel XMM 7160 Radio Module</p> <ul style="list-style-type: none"> • GSM 850/900/1800/1900MHz GPRS / EDGE Multi-slot class 33 operation • WCDMA / HSPA+ 850/900/1700/1900/2100 MHz • LTE 700/800/850/900/1700/1800/1900/2100/2600 <p>Wi-Fi, BT LE (2.4 GHz band of operation and 5GHz band of operation) GPS 1575.42 MHz</p>

3.2 Identification of the Equipment under Test (EUT)

EUT #	Serial Number	Sample	HW/SW Version
1	INV133600934	Radiated/Conducted	PR2D.2

3.3 Identification of Accessory equipment

AE #	Type	Manufacturer	Model	Part Number
1	AC adapter	Salcomp	SC1402	1322100099636

4 Subject of Investigation

The objective of the measurements done by CETECOM, Inc. was to measure the performance of the EUT as specified by requirements listed in the following test standards:

- 47 CFR 2: Title 47 of the Code of Federal Regulations: Chapter I-Federal Communication Commission: Frequency allocations and radio treaty matters; general rules and regulations.
- 47 CFR 15: Title 47 of the Code of Federal Regulations: Chapter I-Federal Communication Commission: Part 15 – Radio Frequency Devices – Subpart C – Intentional Radiators – Section 15.225: Operation within the band 13.110-14.010 MHz.
- 47 CFR 15: Title 47 of the Code of Federal Regulations: Chapter I-Federal Communication Commission: Part 15 – Radio Frequency Devices – Subpart C – Intentional Radiators – Section 15.209: Radiated emissions limits; general requirements.
- RSS-GEN- Issue 3: General Requirements and Information for the Certification of Radio Apparatus.
- RSS-210- Issue 8: Licence-exempt Radio Apparatus (All Frequency Bands): Category 1 Equipment –Annex 2, section 6: Band 13.110-14.010 MHz

4.1 Dates of Testing:

04/30/2014 -02/06/2014

5 Summary of Measurement Results

Test Specification	Test Case	Temperature and Voltage Conditions	Pass	Fail	NA	NP	Model(s) Tested	Result
FCC §15.225 (a) RSS-210 A2.6 (a)	In-band Emissions	Nominal	■	□	□	□	DZ110	Complies
FCC §15.225 € RSS-210 A2.6	Frequency Tolerance	Nominal & Extreme	■	□	□	□	DZ110	Complies
§15.209 §15.225 (d) RSS-Gen 7.2.5	TX Radiated Spurious Emissions	Nominal	■	□	□	□	DZ110	Complies
RSS-Gen 4.6.1	Occupied Bandwidth	Nominal	■	□	□	□	DZ110	Reference

Note: NA = Not Applicable; NP = Not Performed

6 In-band Field Strength (Fundamental)

6.1 References

FCC: 215.225 (a)

RSS 210: A2.6 (a)

6.2 Limits

FCC: The field strength of any emissions within band 13.553 – 13.567 MHz shall not exceed 15,848 microvolts/meter (84 dBuV/m) at 30 meters distance.

To convert 30 meter limit to 3 meter limit, using the 20 dB/decade extrapolation factor formula:

Conversion factor (CF) = $20 \log (D/d) = 20 \log (3m / 30 m) = -20dB$

Therefore, 20 dB shall be added to the specified limit (84 dBuV @ 30 m) to convert to actual test limit **104 dBuV @ 3m**.

RSS 210: The field strength of any emission shall not exceed the following limits:

(a) 15.848 millivolts/m (84 dB μ V/m) at 30 meters, within the band 13.553-13.567 MHz.

6.3 Test Conditions

Tnom: 24°C

Vnom: 3.8 V dc

6.4 Radiated Measurement Procedure

Ref: ANSI/TIA-603-C-2004 & RSS-Gen Section 4.8

Field Strength measurement

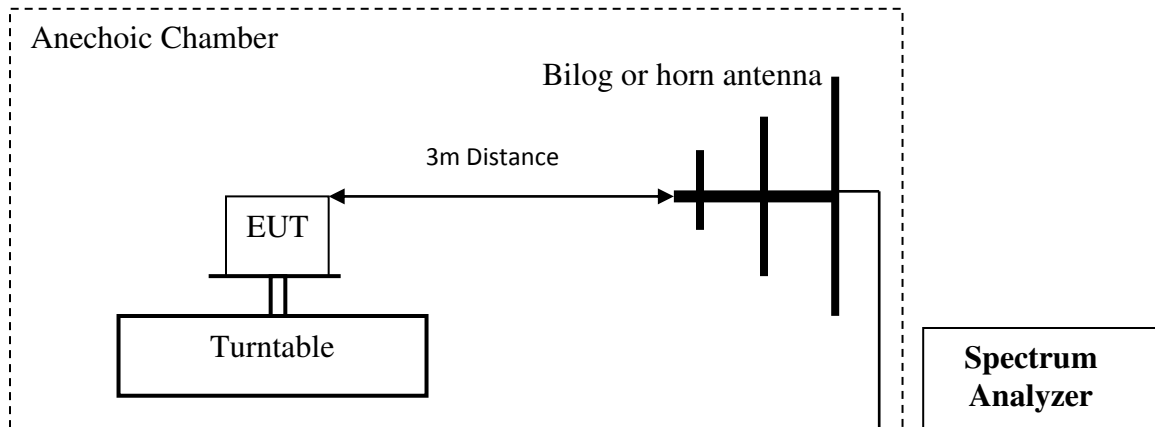

1. Connect the equipment as shown in the above diagram with the EUT's antenna in a vertical orientation.
2. Set the EUT in continuous transmission mode with its maximum power @ 98% - 100% duty cycle.
3. Set the spectrum analyzer to the channel frequency of interest.
4. Maximize the emission amplitude by rotating the turntable 0 - 360°, adjusting the measuring antenna height from 1 – 4 m & changing antenna polarity.
5. Repeat steps 4 with all antennas different polarity and determine the maximized polarity for measurement. Measure and record the peak level of field strength (**LVL**) in dBuV.
6. Adjust correction factors to the measured field strength (**LVL**) and using the field strength approach calculation to convert (**LVL**) from dBuV to transmitter output power (EIRP) in Watts using the following equations:
7. Correction factors (**CF**) in dB = Antenna factor (dB) + Cable loss (dB).

$$\mathbf{LVLc\ (dBuV) = LVL\ (dBdBuV) + Correction\ Factors\ (dB)}$$

6.5 Measurement Settings

$RBW \geq OBW$; $VBW \geq RBW$ or $3 \times RBW$

Span= $2 \times RBW$ or wide enough to capture bandwidth of emission being measured

Detector = Peak; Trace = Max Hold

Sweep time: Auto.

6.6 Measurement Uncertainty

+/- 3 dB

6.7 Sample calculation

When the EUT measured by using radiated test method, the field strength (linear) approach calculation by applying the following (4) equations:

$$(1) \quad \text{FS (dBuV/m)} = \text{Measured FS (dBuV/m)} + \text{CF (dB)}$$

Where

- CF = Ant. Factor + Cable Loss – Ext. Amp Gain (if required)
- FS = electric field strength in dBuV/m

Then convert from dBuV to V/m by using the equation (2):

$$(2) \quad \text{FS (V/m)} = 10^{(\frac{\text{dBuV}}{m} - 120)/20}$$

Or convert from uV/m to dBuV/m by using the equation (3):

$$(3) \quad \text{FS (dBuV/m)} = 20 \log (\text{uV/m})$$

When testing at other than specified distance in the standard, the approach calculation by using 40 dB/decade extrapolation factor equation (4) as follow:

$$(4) \quad \text{Conversion factor (CF)} = 20 \log (D/d) = 20 \log (3\text{m} / 30 \text{m}) = -20\text{dB}$$

Where D is actual test distance and d is specified test distance in the standard.

6.8 Test Data Results

Modulation: A							
Frequency (MHz)	Antenna Polarity (H/V)	Antenna Height (m)	Angle (°)	Corr. F (dB)	FS Level (dBuV/m)	Limit @ 3m (dBuV)	Results
13.456	H	1	249	33.5	45.92 Qp	104	Pass

Modulation: B							
Frequency (MHz)	Antenna Polarity (H/V)	Antenna Height (m)	Angle (°)	Corr. F (dB)	FS Level (dBuV/m)	Limit @ 3m (dBuV)	Results
13.559	H	1	183	33.5	46.79 Qp	104	Pass

Modulation: F							
Frequency (MHz)	Antenna Polarity (H/V)	Antenna Height (m)	Angle (°)	Corr. F (dB)	FS Level (dBuV/m)	Limit @ 3m (dBuV)	Results
13.559	H	1	183	33.5	46.66 Qp	104	Pass

6.9 Measurement Verdict

Pass.

6.10 Measurement Plots

NFC (13.56 MHz) –Type A- 106 Kbps

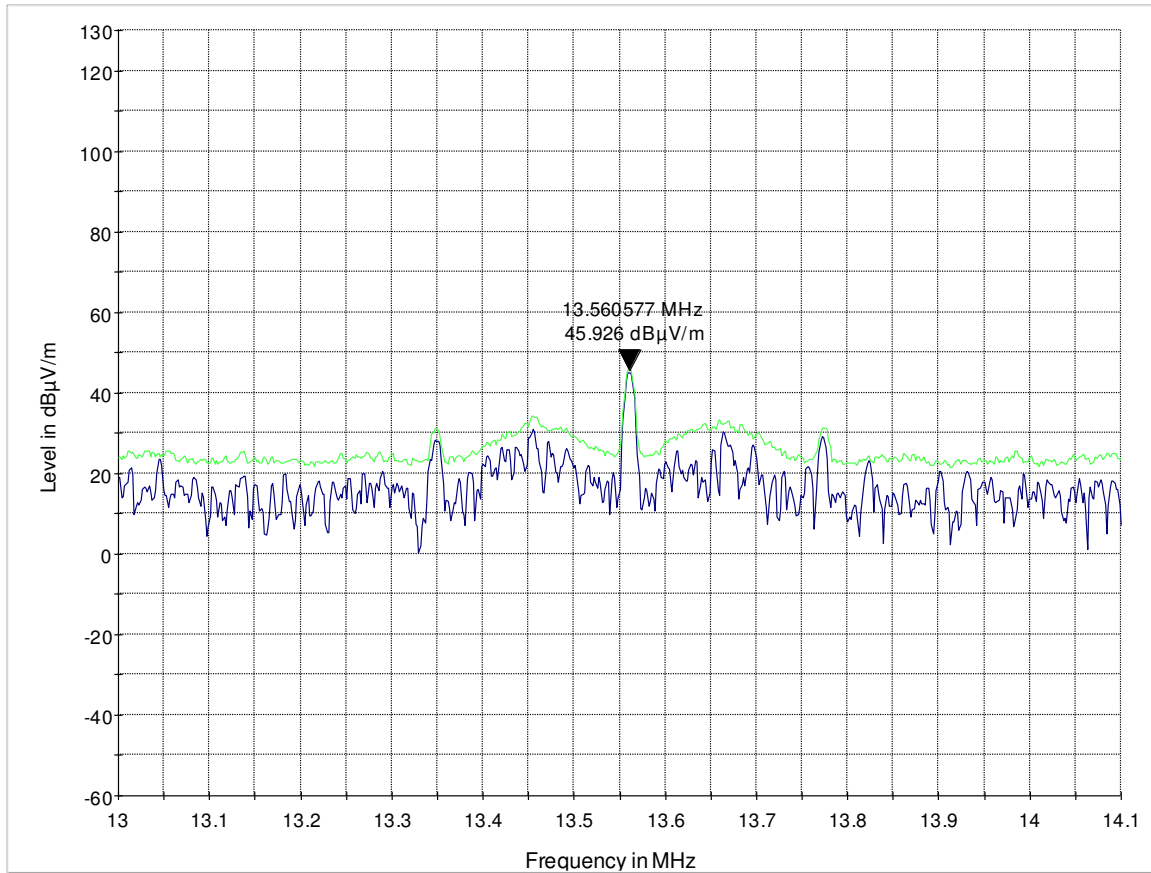

— MaxPeak-ClearWrite-PK+ — MaxPeak-MaxHold-PK+

NFC (13.56 MHz) –Type B- 106 Kbps

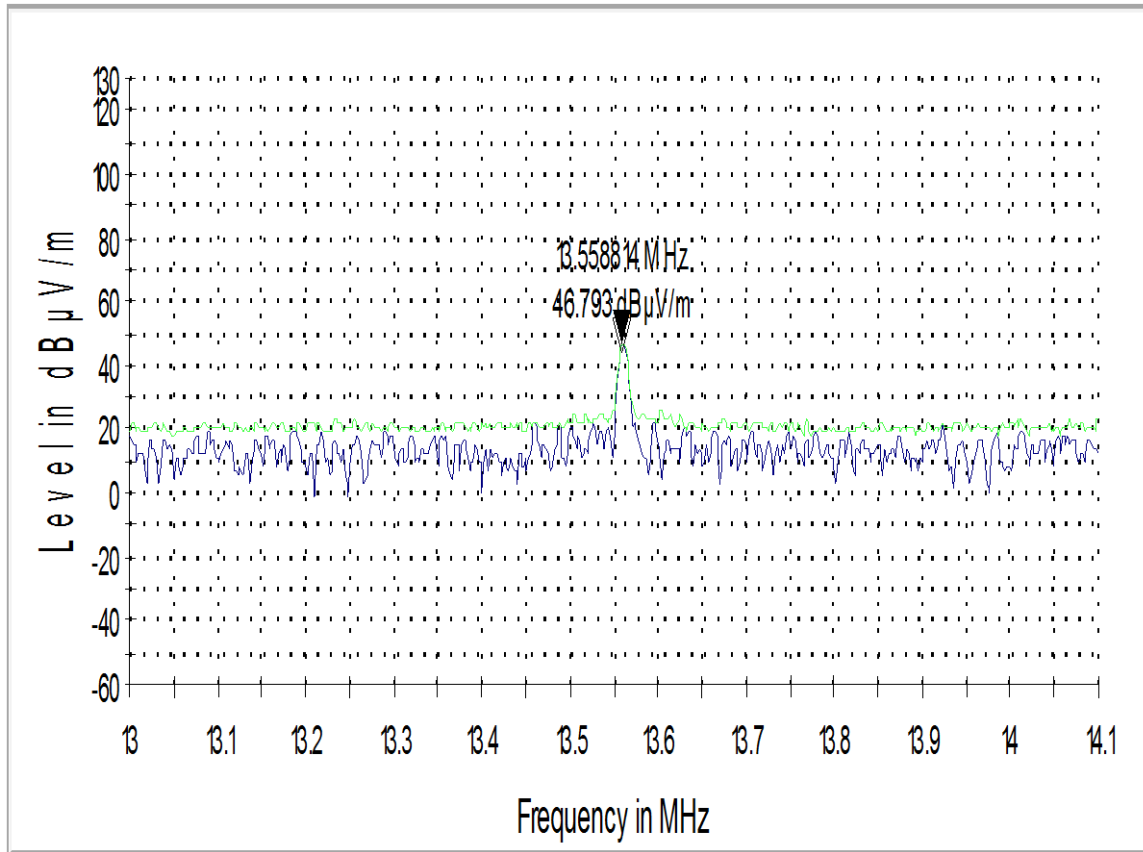

— MaxPeak-ClearWrite-PK+ — MaxPeak-MaxHold-PK+

NFC (13.56 MHz) –Type F- 212 Kbps

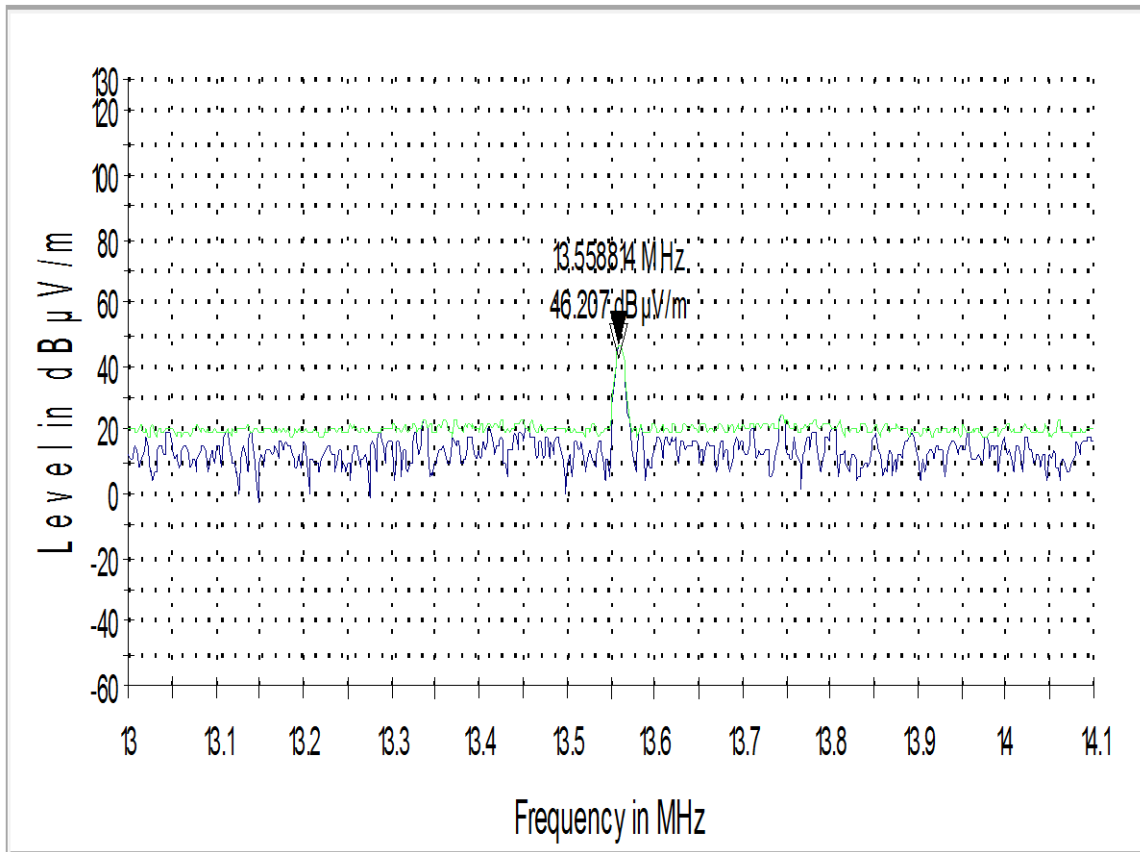

— MaxPeak-ClearWrite-PK+ — MaxPeak-MaxHold-PK+

7 Transmitter Spurious Emissions – Radiated

7.1 Limits

FCC: 15.225 (d)

FCC: 15.209

RSS-Gen 7.2.5

FCC 15.209 & RSS-Gen Section 7.2.5

Frequency (MHz)	Field strength (microvolts/meter)	Measurement distance (m)
0.009–0.490	2400/F(kHz)	300
0.490–1.705	24000/F(kHz)	30
1.705–30.0	30 (29.5 dB μ V/m)	30
30–88	100 (40dB μ V/m)	3
88–216	150 (43.5 dB μ V/m)	3
216–960	200 (46 dB μ V/m)	3
Above 960	500 (54 dB μ V/m)	3

7.2 Measurement Settings

RBW=9 kHz for measurements < 30 MHz

RBW=100 kHz for measurements from 30 MHz – 1 GHz

RBW=1 MHz for measurements > 1GHz

VBW=RBW or 3x RBW

Span= Entire range of measuring antenna or in segment

Detector: Quasi-Peak from 30 MHz – 1 GHz

1GHz < Average < 30 MHz

7.3 Test Conditions

Tnom: 24°C

Vnom: 3.8 V dc

7.4 Radiated test procedure for transmitter spurious emissions:

Ref: ANSI/TIA-603-C-2004 & RSS-Gen Issue 3, section 4.9

Refer to section 12 for test setup diagrams.

1. Connect the equipment as shown in the above diagram with the EUT's antenna in a horizontal orientation.
2. The EUT was set to continuous transmission mode with its maximum power @ 100% duty cycle.
3. Set the spectrum analyzer to measure peak hold with the required settings.
4. Rotate the EUT 360°. Raise the measurement antenna up to 4 meters in 0.5 meters increments and rotate the EUT 360° at each height to maximize all emissions. Measure and record all spurious emissions (**LVL**) up to the tenth harmonic of the carrier frequency.
5. Repeat steps 4, 5 and 6 with all antennas vertically polarized and determine the maximized polarity for measurement.
6. Select 6 closest readings or more to the limits for measurements.
7. Determine the level of spurious emissions using the following equation:
 $LVLc \text{ (dBuV)} = \text{Measured LVL (dBuV)} + CF$

Measurement Survey:

The site is constructed in accordance with ANSI C63.4 requirements and is recognized by the FCC to be in compliance for a 3m site. The spectrum is scanned from 30MHz to the 10th harmonic of the highest frequency generated by the EUT.

NFC Type B was determined to be the worst case emissions mode and was selected for this test.

For radiated measurements, all data in this report shows the worst case emissions data between H/V antenna polarizations and for all 3 orthogonal orientations of the EUT.

7.5 Measurement Uncertainty

+/- 3dB

7.6 Test Data

Radiated Emissions: 30M- 1GHz

Test Mode: NFC Type B										
Frequency (MHz)	Peak (dBµV/m)	Quasi- Peak (dBµV/m)	Bandwidth (kHz)	Height (cm)	Ant. Polarity	Azimuth (deg)	C F (dB)	Limit (dBµV/m)	Margin (dB)	Results
68.06	-----	25.7	120.0	123	V	249.0	7.8	40.0	-14.3	Pass
79.79	-----	21.9	120.0	123	V	173.0	9.2	40.0	-18.1	Pass
187.88	-----	23.1	120.0	100	V	185.0	11.3	43.5	-20.4	Pass
212.47	-----	25.6	120.0	100	V	112.0	12.0	43.5	-17.9	Pass
275.05	-----	32.1	120.0	100	H	270.0	14.8	46.0	-13.9	Pass
533.62	-----	20.3	120.0	123	V	180.0	21.2	46.0	-25.8	Pass
647.55	-----	23.3	120.0	100	V	172.0	22.8	46.0	-22.7	Pass
942.83	-----	27.0	120.0	100	V	112.0	27.0	46.0	-19.0	Pass

7.7 Measurement Verdict

Pass.

7.8 Measurement Plots

Spurious Emissions: 9 KHz – 30MHz –NFC Type B

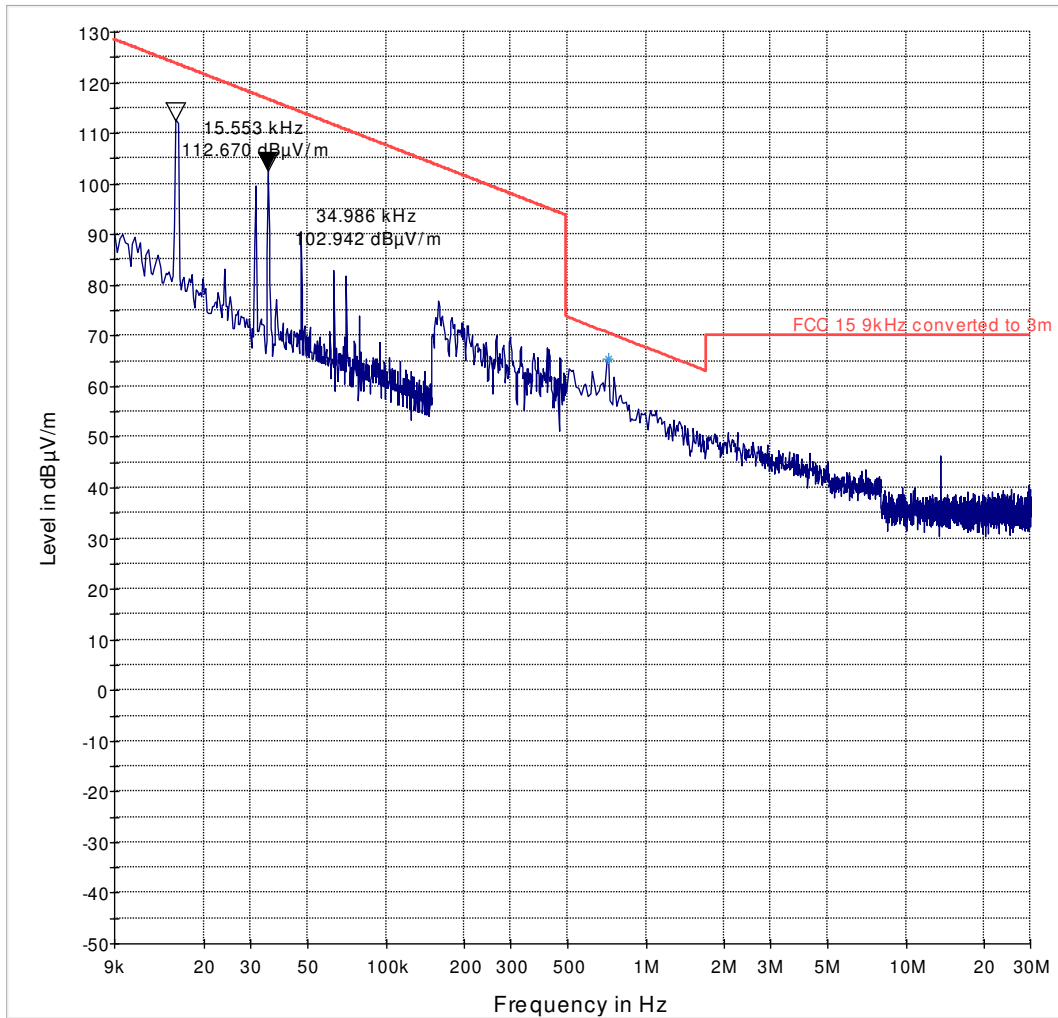

— FCC 15.9kHz converted to 3m — Preview Result 1-PK+ * Data Reduction Result 1 [1]-PK+

Spurious Emissions: 30 MHz – 1 GHz –NFC Type B

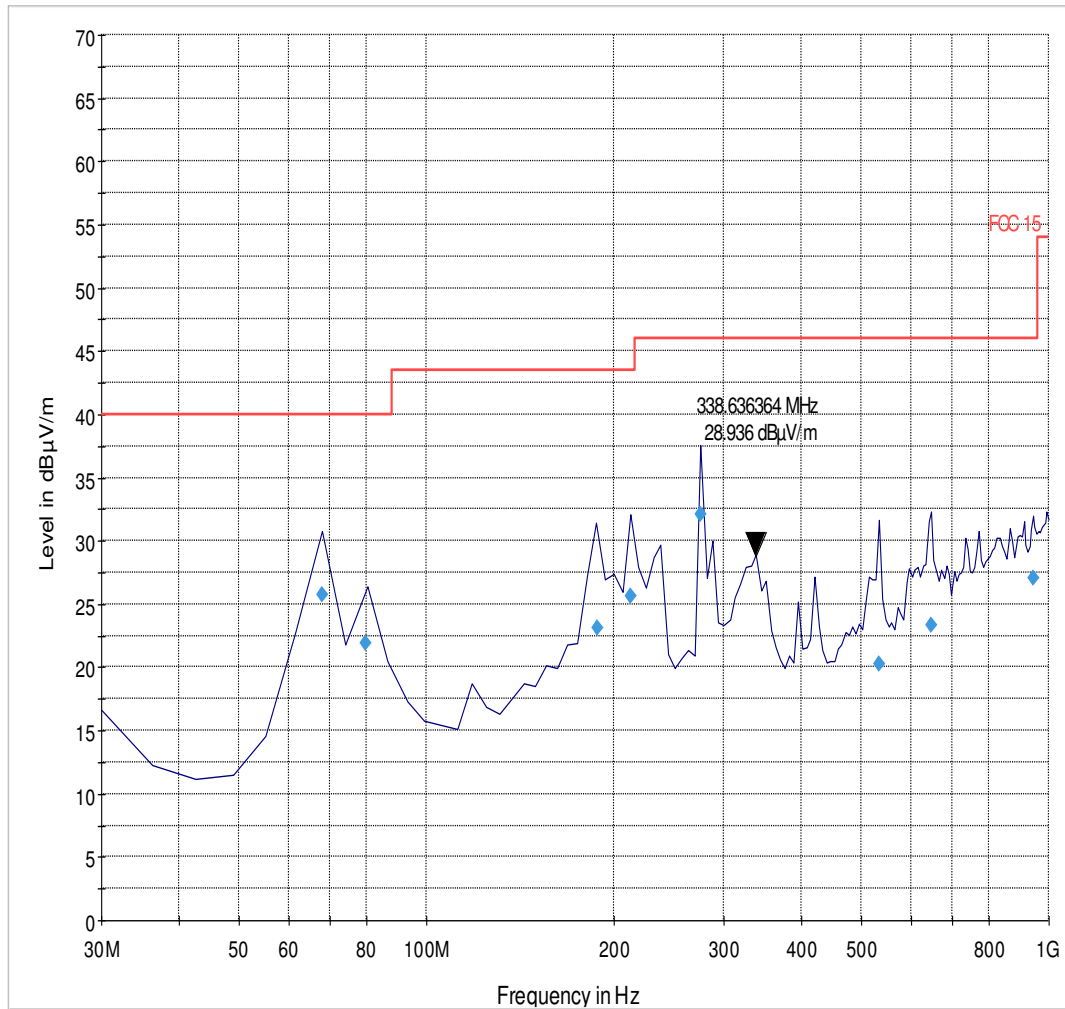

— FCC 15 — Preview Result 1-PK+ ◆ Final Result 1-QPK

8 Frequency Tolerance

8.1 References

FCC: 15.225 (e)

RSS-210 A2.6

8.2 Limits

FCC: $\pm 0.01 \%$

RSS-210: $\pm 0.01 \%$

8.3 Test Conditions

Tnom: 24°C

Vnom: 3.8 V dc

8.4 Test Data

Frequency Tolerance vs. Voltage Source		
Test Mode: NFC Type B		
Voltage Source (Vdc)	Measured Frequency (MHz)	Tolerance Deviation (%)
Vnom = 3.8	13,559840	-0.0011
Vmax = 4.2	13,560820	0.0060
Vmin = 3.6	13,559520	-0.0035

Frequency Tolerance vs. Temperature		
Test Mode: NFC Type B		
Temperature °C	Measured Frequency (MHz)	Tolerance Deviation (%)
55	13,560801	0.0059
40	13,560160	0.0012
30	13,561121	0.0083
20	13,559839	-0.0012
10	13,560641	0.0047
0	13,560481	0.0035
-10	13,559359	-0.0047
-20	13,559519	-0.0035

8.5 Measurement Verdict

Pass.

9 Occupied Bandwidth

The recovered amplitude data points, beginning at the lowest frequency, are placed in a running sum until 0.5% of the total is reached and that frequency recorded. The process is repeated for the highest frequency data points. This frequency is recorded. The span between the two recorded frequencies is the occupied bandwidth of the 99 %.

9.1 References

RSS-Gen 4.6

9.2 Limits

RSS-Gen 4.6.1

When an occupied bandwidth value is not specified in the applicable RSS, the transmitted signal bandwidth to be reported is to be its 99% emission bandwidth, as calculated or measured.

9.3 Measurement Settings

Measurement according to RSS-Gen 4.6.1

For 99% occupied Bandwidth, use the occupied bandwidth measurement function with the band set equal to 99% emission bandwidth.

Span = wide enough to capture the entire emission bandwidth

RBW = or as close to 1% of the span

VBW \geq RBW or 3X

Sweep = auto

Detector function = peak

Trace = max hold

9.4 Test Data

Modulation: ASK				
Date Rate: 250 KHz				
NFC Type	Frequency (MHz)	99% BW (Hz)	Limit (KHz)	Result
A	13.56	111.0	None	Reference
B	13.56	111.0	None	Reference
F	13.56	110.5	None	Reference

9.5 Measurement Plots

NFC (13.56 MHz) –Type A- 106 Kbps – 99% Bandwidth

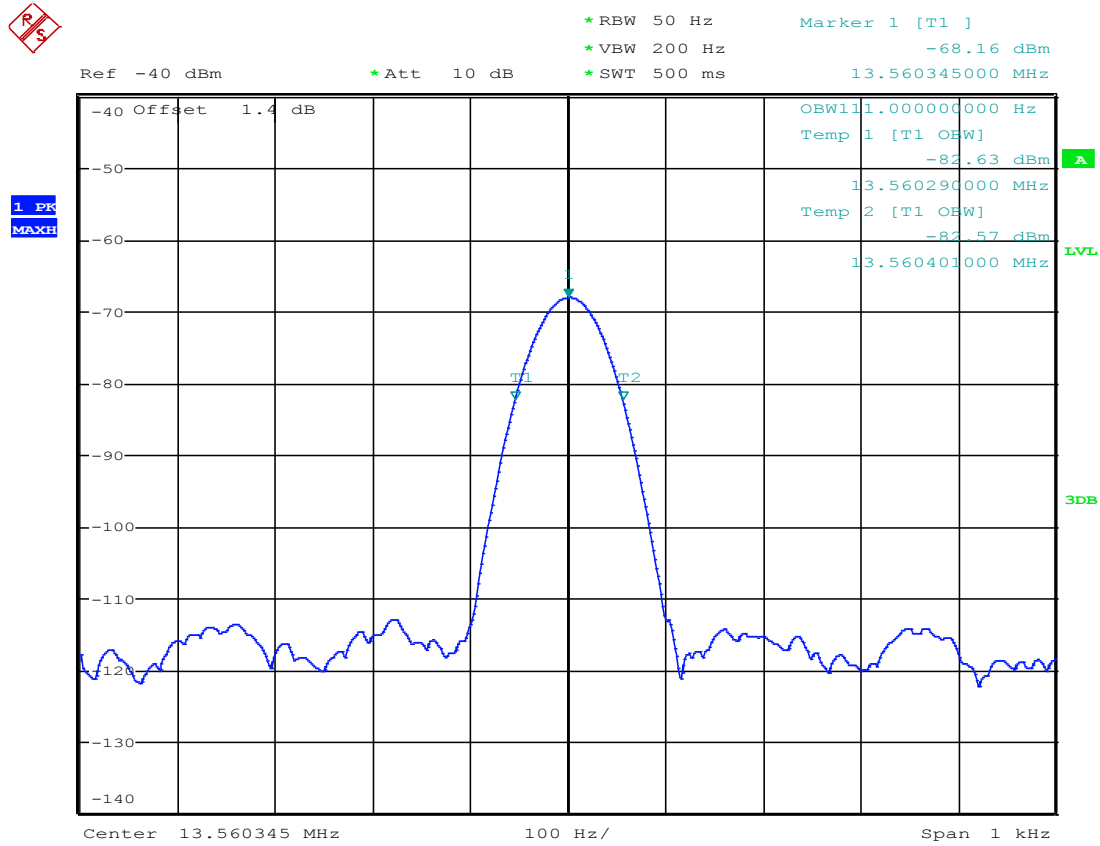

Date: 2.JUN.2014 23:34:11

NFC (13.56 MHz) –Type B- 106 Kbps – 99% Bandwidth

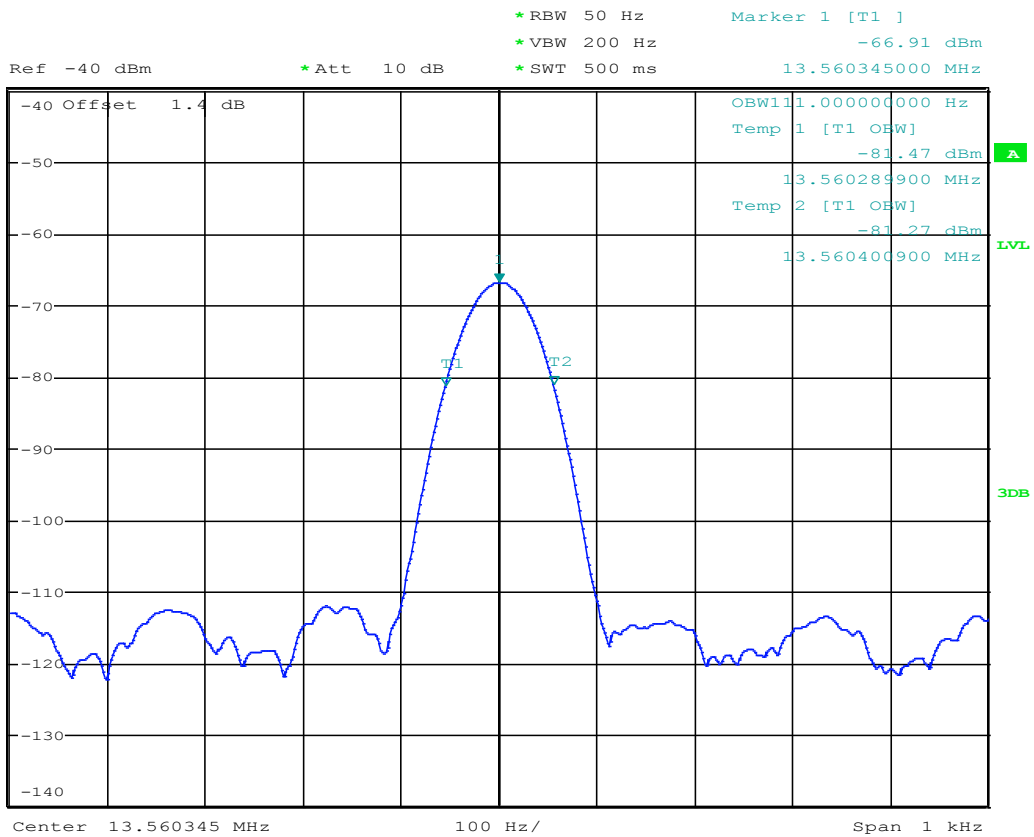

Date: 2.JUN.2014 23:35:54

NFC (13.56 MHz) –Type F- 212 Kbps – 99% Bandwidth

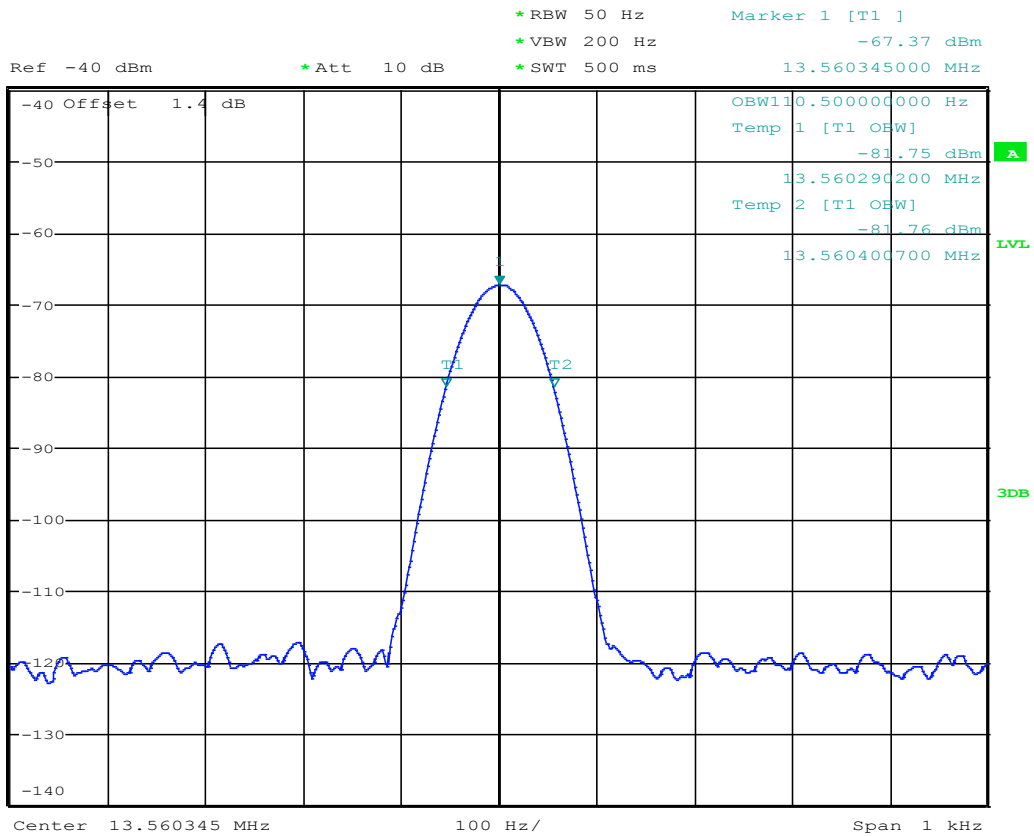

Date: 2.JUN.2014 23:37:44

10 Test Equipment

No.	Equipment Name	Manufacturer	Type/model	Serial No.	Cal Date	Cal Interval
3m Semi- Anechoic Chamber:						
	Turn table	EMCO	2075	N/A	N/A	N/A
	MAPS Position Controller	ETS Lindgren	2092	0004-1510	N/A	N/A
	Antenna Mast	EMCO	2075	N/A	N/A	N/A
	Relay Switch Unit	Rohde&Schwarz	RSU	338964/001	N/A	N/A
	EMI Receiver/Analyzer	Rohde&Schwarz	ESU 40	100251	Sept 2013	1 Years
	Spectrum Analyzer	Rohde&Schwarz	FSU	200302	Jun 2013	2 Years
	1500MHz HP Filter	Filtek	HP12/1700	14c48	N/A	N/A
	2800 MHz HP Filter	Filtek	HP12/2800	14C47	N/A	N/A
	Pre-Amplifier	Miteq	JS40010260	340125	N/A	N/A
	Loop Antenna	EMCO	6512	00049838	Apr 2012	3 years
	Binconilog Antenna	EMCO	3141	0005-1186	Apr 2012	3 Years
	Binconilog Antenna	ETS	3149	J000123908	Feb 2012	3 years
	Horn Antenna	EMCO	3115	35114	Mar 2012	3 Years
	LISN	R&S	ESH3-Z5	836679/003	Jun 2013	3 Years
	Temp Hum Logger	TM325	Dickson	5285354	Apr 2013	2 Year
	Climatic Chamber	Votsch	VT4004	G1115	N/A	N/A

Equipment used meets the measurement uncertainty requirements as required per applicable standards for 95% confidence levels.

Calibration due dates, unless defined specifically, falls on the last day of the month.

Items indicated "N/A" for cal status either do not specifically require calibration or is internally characterized before use.

11 Test Setup Diagrams

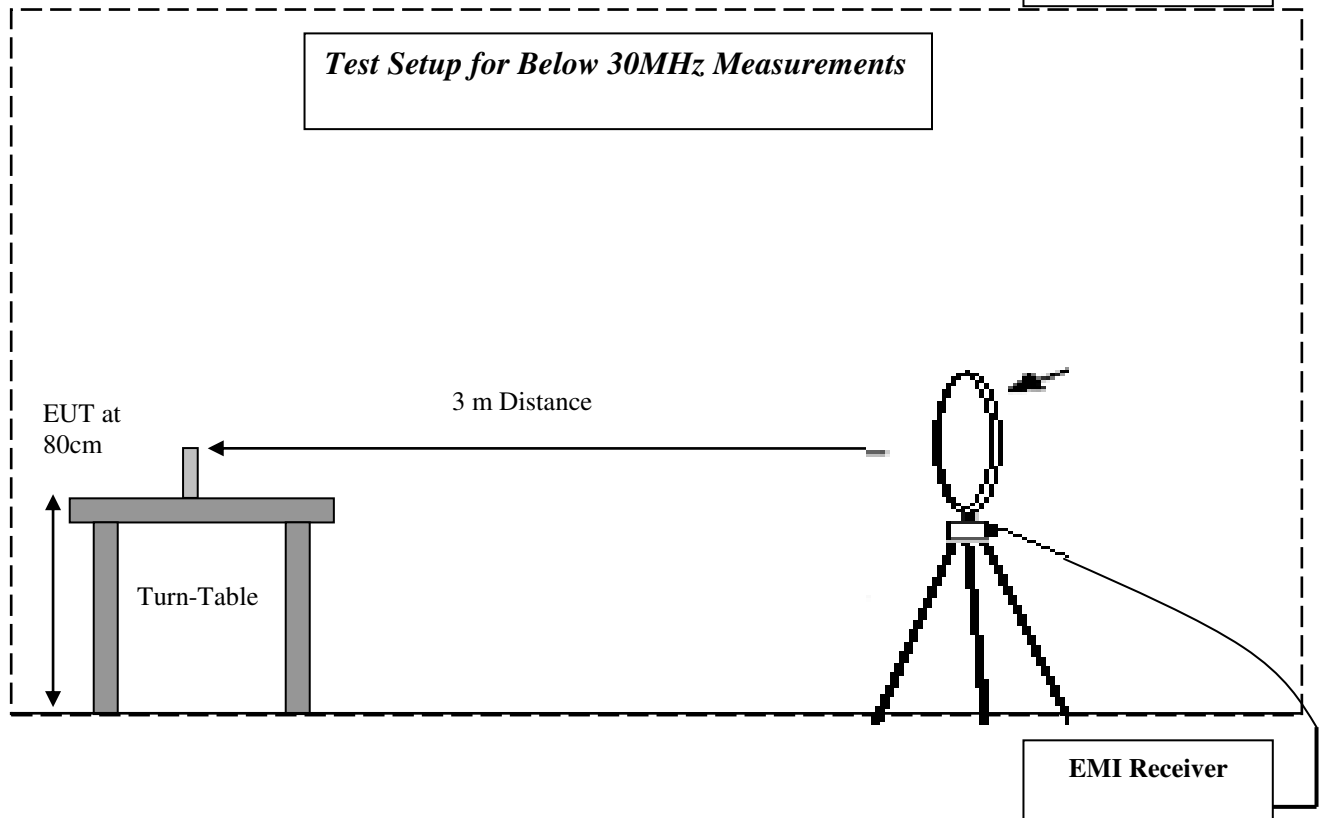
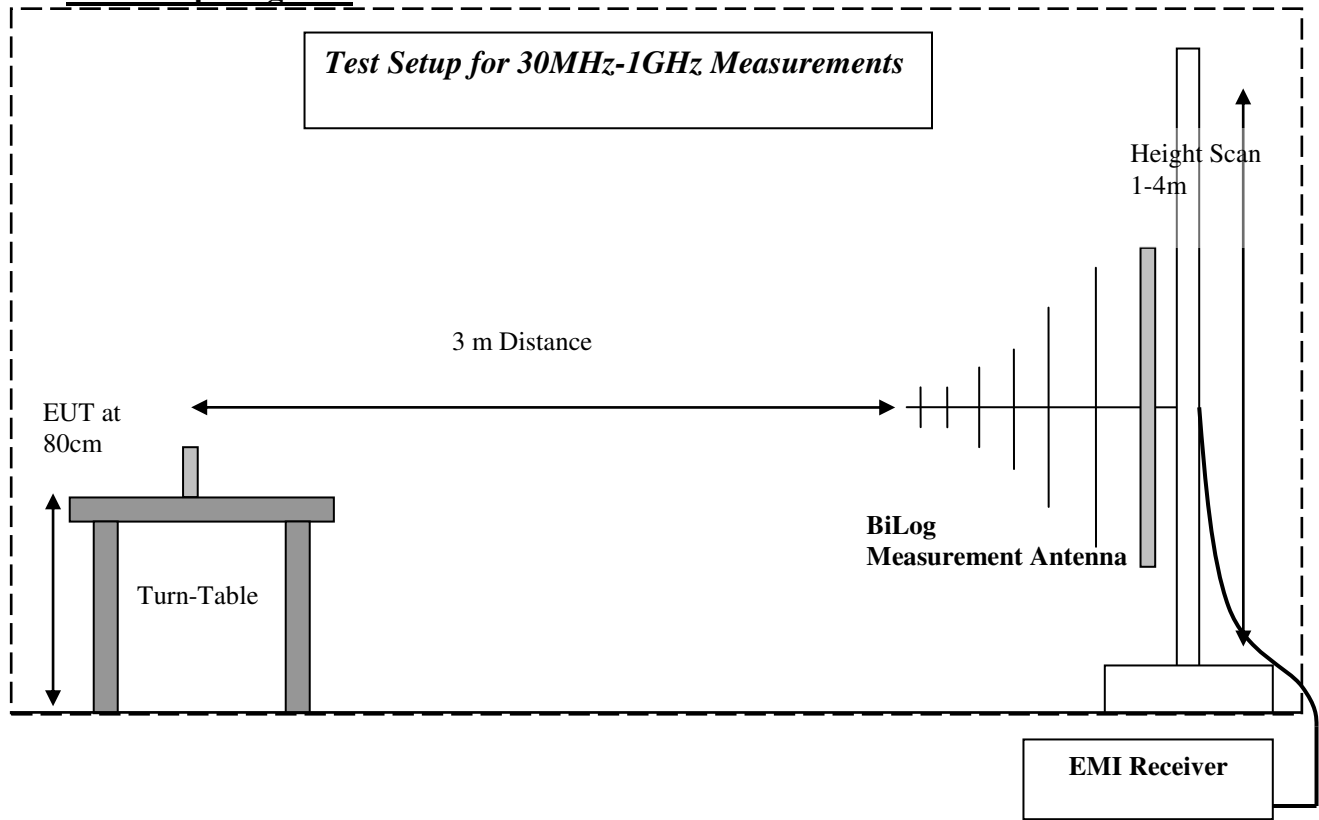

Test Report #: EMC_INTEL-039- 14001_FCC15.225_NFC_rev1

Date of Report : 2014-06-03



12 Revision History

Date	Report Name	Changes to report	Report prepared by
2014-06-03	EMC_INTEL-039- 14001_FCC15.225_NFC_rev1	Product description updated	Danh Le