

EXHIBIT B – Technical Report

FCC ID O2Z-BT2

# Measurement/Technical Report

**Intel Corporation**

**Intel(R) Personal Wireless Module**

**FCC ID: O2Z-BT2**

**February 14, 2001**

This report concerns (check one):		Original Grant <u>X</u>	Class II Change <u>    </u>
Equipment Type: <u>Unlicensed Spread Spectrum Transmitter Module</u>		Rule Part: <u>47 CFR 15.247</u>	
Deferred grant requested per 47 CFR 0.457 (d)(1)(ii)?		Yes <u>    </u> no <u>X</u>	
If yes, defer until:		<u>    N/A    </u> date	
Intel Corp. agrees to notify the Commission by:		<u>    N/A    </u> date	
of the intended date of announcement of the product so that the grant can be issued on that date.			
Transition Rules Request per 15.37:		yes <u>    </u> no <u>X</u>	
If no, assumed Part 15, Subpart C for intentional radiators – new 47 CFR [10-1-92] provision.			
Report prepared by:	Northwest EMC, Inc. 22975 NW Evergreen Pkwy., Ste 400 Hillsboro, OR 97124 (503) 844-4066 fax: (503) 844-3826		
Report No. INSC0011			

## Table of Contents

Section	Description	Page
1.0	General Information	3
1.1	Product Description	3
1.2	Related Submittals/Grants	5
1.3	Tested System Details	5
1.4	Test Methodology	6
1.5	Test Facility	6
3.0	System Test Configuration	7
3.1	Justification	7
3.2	EUT Exercise Software	7
3.3	Special Accessories	7
3.4	Equipment Modifications	7
Figure 3.1	Configuration of Tested System	8
4.0	Antenna Requirement	9
4.1	Antenna Information	9
4.2	Frequency Hopping System	9
4.3	Frequency Hopping Receiver	9
4.4	DeFacto EIRP Limit	10
4.5	RF Exposure Compliance Requirements	10
4.6	AC Powerline Conducted Emissions	11
4.7	Spurious Radiated Emissions Data	12
4.8	Occupied Bandwidth	13
4.9	Peak Output Power	14
5.0	Spurious RF Conducted Emissions	15
5.1	Band Edge Compliance of RF Conducted Emissions	16
5.2	Carrier Frequency Separation	17
5.3	Time of Occupancy (Dwell Time)	18
5.4	Number of Hopping Frequencies	19
5.5	Power Spectral Density	20
5.6	Processing Gain	21
5.7	Field Strength Calculations	22
5.8	Measurement Bandwidths	22
6.0	Measurement Equipment	23

**1.0 General Information**

**1.1 Product Description**

Manufactured By ..... Intel Corporation  
Address.....2200 Missions College Blvd., Santa Clara, CA 95052-8119  
Test Requested By:..... Al Bettner  
Model.....Intel(R) Personal Wireless Module  
FCC ID.....O2Z-BT2  
Serial Number(s) ..... new module #2 1/15/01  
Date of Test.....January 12, 2001 through February 14, 2001  
Job Number ..... INSC0011

**Prepared By:**

*Vicki Albertson*

\_\_\_\_\_  
Vicki Albertson, Technical Report and Documentation Manager

**Technical Review By:**

*Greg Kiemel*

\_\_\_\_\_  
Greg Kiemel, Director of Engineering

**Approved By:**

*Don Fecteau*

\_\_\_\_\_  
Don Fecteau, IS Manager

## **1.1 Product Description con't**

The Equipment Under Test (EUT) is the Intel® Personal Wireless Module, a spread spectrum transmitter that uses frequency hopping modulation. This device is intended to be sold to Original Equipment Manufacturers (OEMs) for integration into laptop computers only. This device will be integrated with one of four Intel sponsored antennas, which are being recommended to be used with this device. The module will allow laptop computers to communicate with other consumer electronics containing Bluetooth® devices. This will allow a laptop computer to communicate to and share files and data with other devices such as digital cameras, cellular phones, wireless mice, wireless joysticks, wireless keyboards, etc.

Within the Bluetooth® protocol, frequency hopping is governed by one and only one Bluetooth® unit in any given communications group. The master unit determines the pseudo random hopping sequence and conveys this information to other “slave” units that are in the communications group with the master. Because the master unit generates the hopping sequence independently without any external information, there is no coordination with other FHSS systems. The Bluetooth® protocol relies on Forward Error Correction (FEC) along with re-transmissions to accommodate for multiple transmitters and interference on specific frequencies.

Under two specific modes (page mode and inquiry mode) of the Bluetooth® protocol, fewer than 75 hopping frequencies are used for a very short period of time. These two modes are used to search for and acquire new devices in the surrounding area. The amount of time that a Bluetooth® device spends in these two modes represents a very small portion of the overall communications time.

The data transmitted during these two modes is Direct Sequence modulated. Even though the transmitter is still hopping to a pseudo-random hopping sequence (less than 75 frequencies), the data transmitted at each frequency is Direct Sequence modulated. In this regard, the transceiver qualifies as a Hybrid System under the Part 15.247 rules.

Because the Bluetooth protocol contains these modes, and because these modes do not meet the minimum number of hopping channels specified in Part 15.247 for frequency hopping, the Bluetooth transmitter is categorized as a hybrid system for these two modes and the hybrid-mode processing gain calculations apply.

## 1.2 Related Submittals/Grants

None

## 1.3 Tested System Details

### EUT and Peripherals

Item	FCC ID	Description and Serial No.
EUT	O2Z-BT2	Intel(R) Personal Wireless Module Spread Spectrum Transmitter S/N new module #2 1/15/01.
3.3V DC Power Supply	N/A	Instek PC-3030D, S/N 9565963
PIFA	N/A	Antenna "B" *
Multilayer	N/A	Antenna "C" *
Dielectric	N/A	Antenna "D" *
Microstrip	N/A	Antenna "E" *

### Cables

Cable Type	Shield	Length (meters)	Ferrite	Connection Point 1	Connection Point 2
USB	No	1.0	No	USB port on EUT	Unterminated
DC	No	1.0	No	DC Input on EUT	DC Power Supply
Antenna Coax	Yes	2 (inches)	No	RF Output on EUT	Antenna

*\*Additional antenna specifications may be referenced in Exhibit G, file name "Antenna Information.pdf"*

## **1.4 Test Methodology**

Radiated testing was performed according to the procedures in ANSI C63.4 (1992), FCC 97-114, and DA 00-705. Radiated testing was performed at an antenna to EUT distance of 3 meters, from 30 MHz to 8 GHz, and at 1 meter from 8 GHz to 25 GHz.

## **1.5 Test Facility**

The semi-anechoic chamber and conducted measurement facility used to collect the radiated and conducted data is located at

Northwest EMC, Inc.  
22975 NW Evergreen Pkwy., Ste 400  
Hillsboro, OR 97124  
(503) 844-4066  
Fax: 844-3826

The semi-anechoic chamber, and conducted measurement facility is located in Hillsboro, OR, at the address shown above. This site has been fully described in a report filed with the FCC (Federal Communications Commission), and accepted by the FCC in a letter maintained in our files.

Northwest EMC, Inc. is recognized under the United States Department of Commerce, National Institute of Standards and Technology, National Voluntary Laboratory Accreditation Program (NVLAP) for satisfactory compliance with criteria established in Title 15, Part 285 Code of Federal Regulations. These criteria encompass the requirements of ISO/IEC Guide 25 and the relevant requirements of ISO 9002 (ANSI/ASQC Q92-1987) as suppliers of calibration or test results. NVLAP Lab Code: 200059-0.

## 3.0 System Test Configuration

### 3.1 Justification

#### 3.1.1 Operating Modes

All operating modes of the EUT were investigated including connect, inquiry, and page modes. During spurious radiated emissions testing, the carrier was put into a no-hop mode while being modulated with a PRBS signal at the maximum data rate. In this configuration, each of the four antennas was tested at low, mid, and high transmit frequencies.

An additional test was performed to demonstrate the suitability of the EUT as a certified transmitter module. The peak output power was measured across a range of DC input voltages. This provided evidence of the EUT's power supply regulation.

*The variable supply voltage data may be referenced in Exhibit "Y",  
file name "Output Power vs DC Input.pdf".*

#### 3.1.2 Test Configuration

In FCC Public Notice DA 00-1407, the requirements for modular approval are outlined. To paraphrase, a module must have its own RF shielding, buffered modulation / data inputs, power supply regulation, permanently attached or unique antenna coupler, and be tested in a stand-alone configuration.

During testing, the EUT was configured to demonstrate compliance with these requirements. The module was tested in a stand-alone configuration. One meter unshielded cables were attached to the USB and DC input ports of the EUT. A short (less than 2 inches) coaxial cable was attached to the RF output port of the EUT for connection of the antennas. A laboratory DC power supply provided power to the EUT.

### 3.2 EUT Exercise Software

The software used to exercise the EUT is engineering developmental software designed to provide manual control over the transceiver functions. The software operates on a laptop computer and commands the EUT via communication over a USB cable through the USB port of the computer. After the EUT was commanded to a particular state, the USB cable was disconnected from the laptop computer for testing.

The EUT contains a built-in microprocessor and memory storage for processing transceiver instructions in accordance to the Bluetooth® protocols.

This software commands the built-in Bluetooth® protocols within the module in the same manner as the final Bluetooth® end-product (laptop computers are the end-product for this module).

The packets selected for transmission during EUT testing were the maximum packet density and data rate allowed in the Bluetooth® protocol to create a worst case emissions.

### 3.3 Special Accessories

None

### 3.4 Equipment Modifications

None.



**Figure 3.1: Configuration of Tested System**

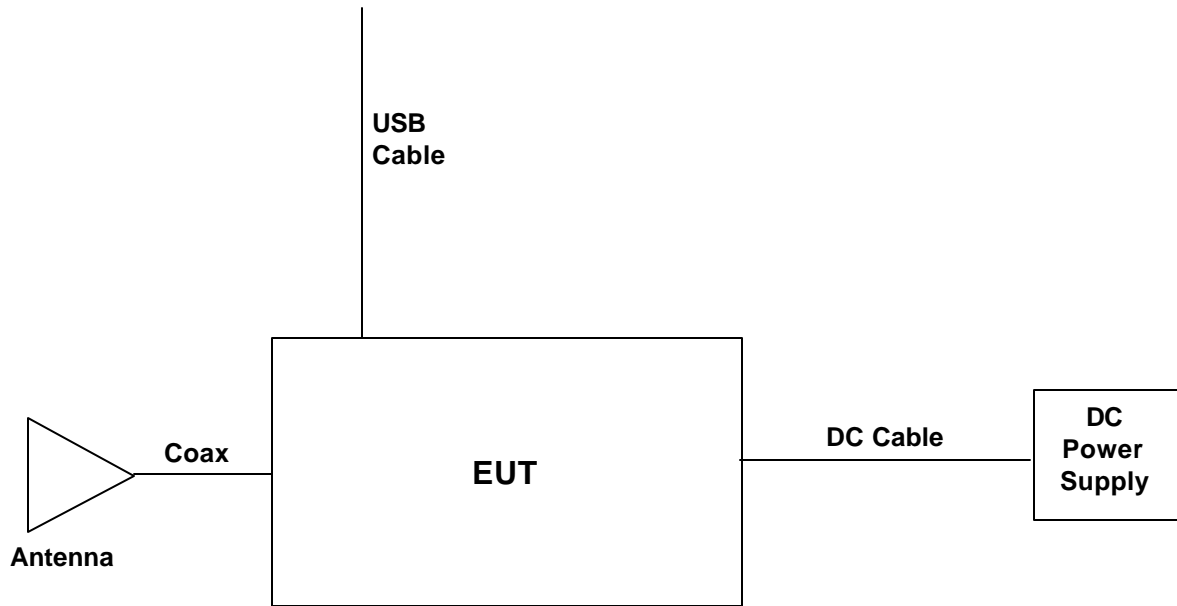

## 4.0 Antenna Requirement

Per 47 CFR 15.203, the EUT uses antennas that are designed to ensure that no other antennas other than those supplied by Intel will be used with the device.

*Details about the antenna connection method may be referenced in exhibit “CC”, file name “Antenna Connection Method.pdf”*

## 4.1 Antenna Information

Per 47 CFR 15.204 (c), a list of antennas tested with the EUT is provided. The type, manufacturer, model number, and gain with reference to an isotropic radiator is given.

*Please reference exhibit “G”, file name “Antenna Information.pdf” for that information.*

*Photographs of those antennas are in exhibit “E”, file name “External Photos.pdf”*

## 4.2 Frequency Hopping System

Per 47 CFR 15.247(a), a description of how the EUT meets the definition (found in 47 CFR 2.1) of a frequency hopping spread spectrum system is provided.

The description includes the number of hopping frequencies, the time of occupancy (dwell time) per hopping channel, and an explanation of how the hopping sequence is generated (an example is provided of the hopping channel sequence). Also, a description of how the EUT’s hopping channels are used equally on average is provided.

In an effort to avoid the simultaneous occupancy of individual hopping frequencies by multiple transmitters; a description is provided of how the EUT does not have the ability to coordinate with other frequency hopping systems.

*Please reference exhibit “K”, file name “Description of Frequency Hopping System” for that information*

## 4.3 Frequency Hopping Receiver

Per 47 CFR 15.247 (a)(1), a description is provided of how the EUT’s associated receiver complies with the requirement that the input bandwidth matches the hopping channel bandwidth of the transmitter, and shifts frequencies in synchronization with the transmitted signals.

*Please reference exhibit “K”, file name “Description of Frequency Hopping System” for that information*

## 4.4 De Facto EIRP Limit

Per 47 CFR 15.247 (b)(1-3), the EUT meets the de facto EIRP limit of +36dBm. The peak output power of the EUT is approximately 3.8 dBm, and the maximum gain of any antennas used with the EUT will be 4 dBi or less. Therefore, the EUT's maximum EIRP is +7.8dBm.

## 4.5 RF Exposure Compliance Requirements

Per 47 CFR 15.247 (b)(4), the EUT meets the requirement that it be operated in a manner that ensures the public is not exposed to radio frequency energy levels in excess of the Commission's guidelines (ref . 47 CFR 1.1307, 1.1310, 2.1091, and 2.1093. Also OET Bulletin 65, Supplement C).

The EUT will only be used in notebook and desktop computers and can therefore be considered a mobile transmitter per 47 CFR 2.1091. It will not be used in "palm-top" computers or other handheld devices. The EUT supports the connection of only one antenna at a time.

The MPE estimates are as follows:

Table 1 in 47 CFR 1.1310 defines the maximum permissible exposure (MPE) for the general population as  $1\text{mW}/\text{cm}^2$ . The distance from the EUT's transmitting antenna where the exposure level reaches the maximum permitted level is calculated using the general equation:

$$S = (PG)/4\pi R^2$$

Where:

- S = power density ( $1\text{mW}/\text{cm}^2$  maximum permitted level)
- P = power input to the antenna (2.404 mW)
- G = linear power gain relative to an isotropic radiator (4dBi = numeric gain of 2.5)
- R = distance to the center of the radiation of the antenna

Solving for R, the  $1\text{mW}/\text{cm}^2$  limit is reached 0.69 cm or closer to the transmitting antenna. Therefore, no warning labels, no RF exposure warnings in the manual, or other protection measures will be used with the EUT.

## 4.6 AC Powerline Conducted Emissions

Per 47 15.207(d), if the EUT is connected to the AC powerline indirectly, obtaining its power from another device, which is connected, to the AC powerline, then it should be tested to demonstrate compliance with the conducted limits of 15.207. The EUT will be powered from a host computer that could be connected to the AC power line. Therefore, in accordance with OET laboratory policy, the measurements were made on the laboratory DC power supply used to power the EUT.

The AC powerline conducted emissions were measured with the EUT operating in a frequency hopping mode typical of normal operation. The EUT was transmitting at its maximum data rate. The spectrum was scanned from 450 kHz to 30 MHz. The test setup and procedures were in accordance with ANSI C63.4-1992.

Per 47 CFR 15.207, the radio frequency voltage that is conducted back onto the AC power line from the EUT, on any frequency within the 450 kHz to 30 MHz band, does not exceed 250 microvolts.

*The AC Powerline conducted emissions data may be referenced in Exhibit "Z",  
file name "AC Powerline Conducted Emissions.pdf".*

## 4.7 Spurious Radiated Emissions

The field strength of any spurious emissions or modulation products that fall in a restricted band, as defined in 47 CFR 15.205, was measured. The highest gain antenna of each type to be used with the EUT was tested. For each type of antenna, the EUT was configured for low, mid, and high band transmit frequencies. For each configuration, the spectrum was scanned from 30 MHz to 25 GHz.

While scanning, emissions from the EUT were maximized by rotating the EUT, adjusting the measurement antenna height and polarization, and manipulating the EUT antenna in 3 orthogonal planes (per ANSI C63.4:1992). A preamp and high pass filter were used for this test in order to provide sufficient measurement sensitivity.

Intel Corporation provides design guidelines to their OEM customers on the possible use of a printed circuit board trace (microstrip) as the antenna connection method. In order to demonstrate compliance with this connection method, an additional series of radiated emissions tests were requested by the FCC lab.

***The Supplemental Emissions Test Report may be referenced in Exhibit "O",  
file name "Supplemental Emissions Test Report.pdf".***

### 4.7.1 Results

The peak level complies with the limits specified in 47 CFR 15.35 (b). The average level (taken with a 10Hz VBW) complies with the limits specified in 15.209.

Since the dwell time per channel of the hopping signal was less than 100 ms, the reading obtained with the 10 Hz VBW may be further reduced by a "duty cycle correction factor", derived from  $20\log(\text{dwell time}/100\text{ms})$ .

***The final radiated data may be referenced in Exhibit "AA",  
file name "Radiated Spurious Emissions.pdf".***

## 4.8 Occupied Bandwidth

The occupied bandwidth was measured with the EUT set to low, medium, and high transmit frequencies. The measurement was made using a direct connection between the RF output of the EUT and the spectrum analyzer. The EUT was transmitting at its maximum data rate in a no hop mode. In order to demonstrate compliance as a Direct Sequence transmitter during the Inquiry and Page modes, the 6 dB bandwidth of the modulated carrier was also measured.

### Frequency Hopping

Per 47 CFR 15.247(a)(1)(ii), the 20 dB bandwidth of a hopping channel is less than 1 MHz. The spectrum analyzer's resolution bandwidth was  $\geq 1\%$  of the 20dB bandwidth and the video bandwidth was greater than or equal to the resolution bandwidth.

Band	Bandwidth (kHz)
Low	745
Mid	765
High	760

### Direct Sequence

Per 47 CFR 15.247(a)(2), the 6 dB bandwidth of a hopping channel is at least 500kHz. The spectrum analyzer's resolution bandwidth was 100kHz, and the video bandwidth was greater than or equal to the resolution bandwidth

Band	Bandwidth (kHz)
Low	506
Mid	500
High	510

***The occupied bandwidth data may be referenced in Exhibit "W", file name "DSSS Occupied Bandwidth.pdf" and Exhibit "P", file name "FHSS 20dB Bandwidth.pdf"***

## 4.9 Peak Output Power

The peak output power was measured with the EUT set to low, medium, and high transmit frequencies. The measurement was made using a direct connection between the RF output of the EUT and the spectrum analyzer. The EUT was transmitting at its maximum data rate

Per 47 CFR 15.247(b)(1), the maximum peak output power does not exceed 1 Watt. The spectrum analyzer's resolution bandwidth was greater than the 20dB bandwidth of the modulated carrier and the video bandwidth was greater than or equal to the resolution bandwidth.

Band	Peak Output Power (mW)
Low	2.404
Mid	2.042
High	1.816

*The Peak Output Power data may be referenced in Exhibit "V",  
file name "Output Power.pdf"*

## 5.0 Spurious RF Conducted Emissions

The spurious RF conducted emissions were measured with the EUT set to low, medium, and high transmit frequencies. The measurements were made using a direct connection between the RF output of the EUT and the spectrum analyzer. The EUT was transmitting at its maximum data rate in a no-hop mode with a modulated carrier. For each mode, the spectrum was scanned from 0 MHz to 25 GHz.

Per 47 CFR 15.247(c), in any 100 kHz bandwidth outside the authorized band, the maximum level of radio frequency power is at least 20dB down from the highest emission level within the authorized band. The spectrum analyzer's resolution bandwidth was 100 kHz and the video bandwidth was greater than or equal to the resolution bandwidth.

*The Conducted Spurious Emissions data may be referenced in Exhibit "T",  
file name "Conducted Spurious Emissions.pdf"*



## 5.1 Band Edge Compliance of RF Conducted Emissions

The spurious RF conducted emissions at the edges of the authorized band were measured with the EUT set to low and high transmit frequencies. The measurement was made using a direct connection between the RF output of the EUT and the spectrum analyzer. The EUT was transmitting at its maximum data rate in a no-hop mode with a modulated carrier. The channels closest to the band edges were selected. The spectrum was scanned across each band edge from 5 MHz below the band edge to 5 MHz above the band edge.

Per 47 CFR 15.247(c), in any 100 kHz bandwidth outside the authorized band, the maximum level of radio frequency power is at least 20dB down from the highest emission level within the authorized band. The spectrum analyzer's resolution bandwidth was 100 kHz and the video bandwidth was greater than or equal to the resolution bandwidth.

*The data for spurious RF conducted emissions at the edges of the authorized band may be referenced in Exhibit "R", file name "Band Edge Compliance.pdf"*

## 5.2 Carrier Frequency Separation

The carrier frequency separation was measured between each of 5 hopping channels in the middle of the authorized band. The measurements were made using a direct connection between the RF output of the EUT and the spectrum analyzer. The hopping function of the EUT was enabled.

Per 47 CFR 15.247(a)(1), the hopping channel carrier frequencies are separated by a minimum of 25 kHz or the 20dB bandwidth of the hopping channel. The spectrum analyzer's resolution bandwidth was greater than or equal to 1% of the span, and the video bandwidth was greater than or equal to the resolution bandwidth.

Measured value of carrier frequency separation for hopping channels is 1 MHz.

*The data for carrier frequency separation may be referenced in Exhibit "Q",  
file name "Channel Spacing.pdf"*

### 5.3 Time of Occupancy (Dwell Time)

The average dwell time per hopping channel was measured at one hopping channel in the middle of the authorized band for three modes of operation (connect, inquiry, and page modes). The measurements were made using a direct connection between the RF output of the EUT and the spectrum analyzer. The hopping function of the EUT was enabled.

Per 47 CFR 15.247(a)(1)(ii), the average time of occupancy for connect mode on any frequency is not greater than 0.4 seconds within a 30 second period. The spectrum analyzer's span was set to zero, the resolution bandwidth was 1 MHz, and the video bandwidth was 7 MHz. The measurement was made in two steps. First, the sweep speed was adjusted to capture the pulse width or dwell time of a single transmission. Then, the sweep speed was set to 5 seconds to count the number of transmissions during a five second period

For connect mode, the dwell time for a single transmission is 360 uS. The average number of transmissions during a five second period is 51. The dwell time, multiplied by the average number of transmissions during a five second period, multiplied by 6, equals the average time of occupancy during a 30 second period.

$$360 \text{ uS} \times 51 \times 6 = 0.275 \text{ seconds (connect mode)}$$

For both inquiry and page modes, per the requirements of 15.247(f), the maximum dwell time cannot exceed 0.4 seconds within a time period in seconds equal to the number of hopping frequencies multiplied by .4. In this case,  $32 \times 0.4 = 12.8$  seconds. The dwell time for a single transmission is 77 uS. The average number of transmissions during a 12.8 second period is 1280. Therefore, the total dwell time in a 12.8 second period is 98.6 mS

***The data for time of occupancy may be referenced in Exhibit "S",  
file name "Dwell Time.pdf"***

## 5.4 Number of Hopping Frequencies

The number of hopping frequencies was measured across the authorized band. The measurements were made using a direct connection between the RF output of the EUT and the spectrum analyzer. The hopping function of the EUT was enabled.

Per 47 CFR 15.247(a)(1)(ii), the number of hopping channels is at least 75. The spectrum analyzer's resolution bandwidth was 100 kHz, and the video bandwidth was greater than or equal to the resolution bandwidth.

*The data for the number of hopping frequencies may be referenced in Exhibit "U",  
file name "Number of Hopping Frequencies.pdf"*

## 5.5 Power Spectral Density

To demonstrate compliance with 15.247(d), power spectral density measurements were made as follows: The emission peak(s) are located and zoom in on within the passband. Set RBW = 3 kHz, VBW>RBW, sweep = (SPAN/3 kHz) e.g., for a span of 1.5 MHz, the sweep should be  $1.5 \times 10^6 \div 3 \times 10^3 = 500$  seconds. The peak level measured must be no greater than +8 dBm. External attenuation is used and added to the reading. If necessary, the following FCC procedure is used for modifying the power spectral density measurements:

*“If the spectrum line spacing cannot be resolved on the available spectrum analyzer, the noise density function on most modern conventional spectrum analyzers will directly measure the noise power density normalized to a 1 Hz noise power bandwidth. Add 34.7 dB for correction to 3 kHz.”*

Data was taken using the 1 Hz noise power bandwidth on an Tektronix 2784 spectrum analyzer. The data summary shown below includes the 34.7 dB correction to 3 kHz. The cable loss and external attenuation of 1.5 dB were corrected internal to the spectrum analyzer.

Low	-4.3 dBm
Mid	-4.4 dBm
High	-4.4 dBm

***The data for Power Spectral Density may be referenced in Exhibit "X",  
file name "DSSS Power Spectral Density.pdf"***

## 5.6 Processing Gain

Processing gain measurements were performed in accordance with the definitions, calculations, and explanation in the test report provided by Intel Corp., found in Exhibit BB, file name "Processing Gain.pdf" .

## 5.7 Field Strength Calculations

The field strength is calculated by adding the Antenna Factor and Cable Factor, and subtracting the Amplifier Gain (if any) from the measured level. The basic equation with a sample calculation is as follows:  
 $FS = RA + AF + CF - AG$

- where :
- FS = Field Strength
  - RA = Measured Level
  - AF = Antenna Factor
  - CF = Cable Attenuation Factor
  - AG = Amplifier Gain

Assume a receiver reading of 52.5 dBuV is obtained. The Antenna Factor of 7.4 and a Cable Factor of 1.1 is added. The Amplifier Gain of 29 dB is subtracted, giving a field strength of 32 dBuV/meter.

$FS = 52.5 + 7.4 + 1.1 - 29 = 32 \text{ dBuV/meter}$   
 Level in uV/m = Common Antilogarithm  $[(32 \text{ dBuV/m})/20] = 39.8 \text{ uV/m}$

## 5.8 Measurement Bandwidths

### Resolution Bandwidth

#### Peak Data

150 kHz - 30 MHz .....	10 kHz
30 MHz - 1000 MHz.....	100 kHz
1000 MHz - 25000 MHz .....	1000 kHz

#### Quasi-peak Data

150 kHz - 30 MHz .....	9 kHz
30 MHz - 1000 MHz.....	120 kHz

#### Average Data.

1000 MHz - 25000 MHz .....	1000 kHz
----------------------------	----------

### Video Bandwidth

The video bandwidth was greater than or equal to the resolution bandwidth for all measurement data except average measurements:

#### Average Data.

1000 MHz - 25000 MHz .....	10 Hz
----------------------------	-------

## 6.0 Measurement Equipment

Instrument	Manufacturer	Model	Serial No	Cal Due
Spectrum Analyzer	Hewlett-Packard	8566B	2747A05213	2/19/2001
Pre-Amplifier	Amplifier Research	LN1000A	25660	12/4/2001
Antenna, Biconilog	EMCO	3141	9906-1146	12/14/2001
Antenna, Horn	EMCO	3115	9804-5441	7/17/2001
Pre-Amplifier 0.5-18 GHz	Miteq	AMF-4D-005180-24-10P	621707	7/7/2001
Spectrum Analyzer	Tektronix	2784	B010105	3/18/2001
Pre-Amplifier 18-26 GHz	Miteq	JSD4-18002600-26-8P	577858	4/10/2001
Antenna, Horn	EMCO	3160-09	9911-1189	01/15/2003
High Pass Filter	Microlab	FXR HD-40N	8402	4/10/2001
Power Meter	Hewlett-Packard	435B	2702A15817	7/10/01
Power Sensor	Hewlett-Packard	8481H	2349A07714	7/10/01