

1. Install the fully charged 9.6v battery pack into the battery compartment of the chassis as shown in (Fig.4)
2. Close and lock the battery compartment cover as shown in (Fig.5)
3. Install the antenna tube to the vehicle as shown in(Fig.6)
4. Turn the on/off switch to the "on" position to operate vehicle as shown in (Fig.7) Switch it "off" when not in use.
5. Install the 9.0v battery into the battery compartment of the transmitter in the correct polarity (Fig.8.)
6. Close the battery compartment cover (Fig.9)
7. Install the transmitter antenna as shown in (Fig.10)

FEATURES AND FUNCTIONS

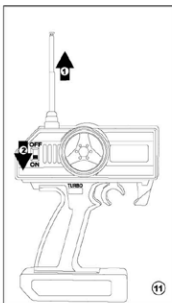

1. Extend the transmitter antenna as shown in (Fig11.)
2. Turn the "on/off" switch to "on" position (Fig11.)

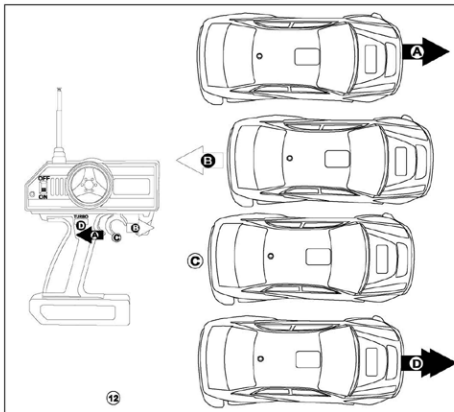

3. Press the trigger inward (Fig.12), the vehicle will move forward.
4. Push the trigger outward (Fig.12), the vehicle will move backward.
5. Release the trigger as in the original position (Fig.12), the vehicle will stop.
6. Press the "turbo" button (fig.12), the vehicle will accelerate forward.

前进时转弯

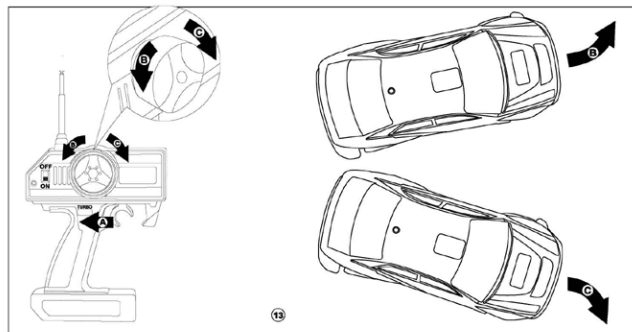

7. when vehicle moves forward, turn the steering wheel counter-clockwise(fig.13), vehicle will turn left.
8. when vehicle moves forward, turn the steering wheel clockwise.(fig.13), vehicle will turn right.

前进时加速转弯

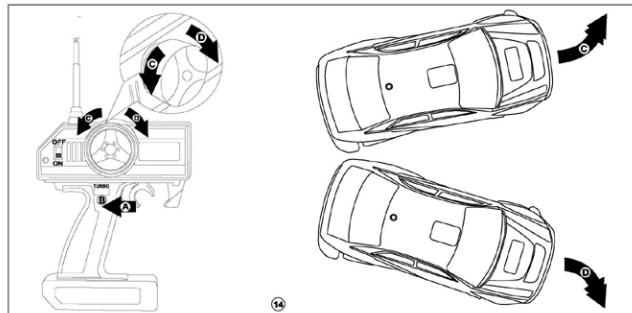

9. press the "turbo" button turn the steering wheel counter-clockwise (Fig.14), vehicle will accelerate forward turn left side.
10. press the "turbo" button turn the steering wheel clockwise (Fig.14), vehicle will accelerate forward turn right side.