

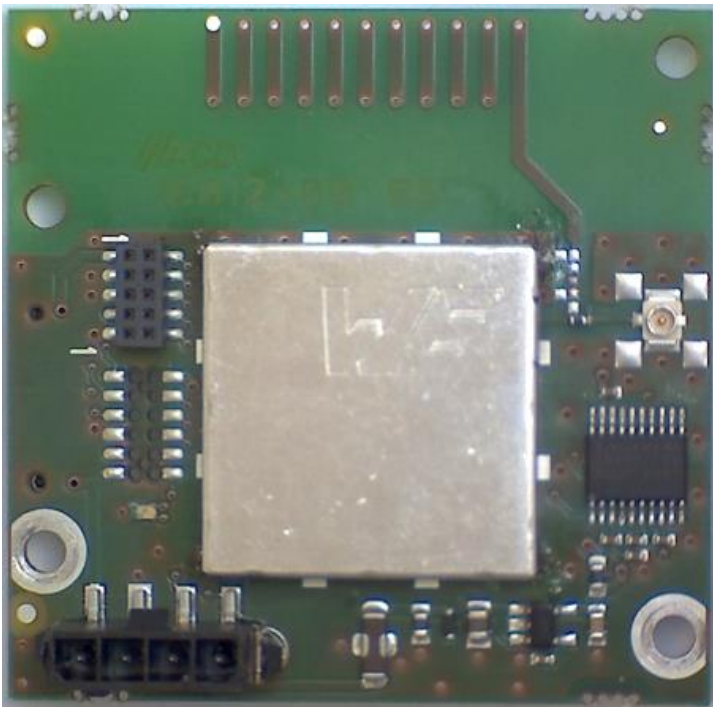

## Integration manual

### Operating instructions X1310 ISM Transceiver - 915MHz

Version: 1.4



© Copyright ACD Gruppe

This document may not be duplicated or made accessible to third parties without permission.



## Contents

1	Scope of delivery.....	3
2	Intended use .....	3
3	Handling .....	4
4	Installation of the components.....	4
4.1	Example for installation.....	4
5	Module description .....	5
5.1	Introduction .....	5
5.1.1	Printed circuit board/module .....	5
5.1.2	Environmental conditions.....	5
5.1.3	System .....	5
5.2	Assembling the PCB module .....	5
5.3	Pin assignment and designation .....	6
5.3.1	X1 connector assignment (host interface) .....	6
5.3.2	X2 connector assignment (host interface) .....	6
5.3.3	X4 connector (HF cable/antenna connection) .....	6
5.3.4	HF cable.....	6
5.4	Antennas .....	6
6	Functional description .....	7
6.1	Control commands and telegrams .....	7
6.2	Control commands in command mode .....	7
6.3	Control commands in data mode .....	8
6.4	Data telegram.....	8
6.5	Acknowledgement telegram.....	8
7	USA/Canada frequency table 915MHz.....	9
8	Service and spare parts .....	10
9	RSS COMPLIANCE STATEMENT.....	11
10	End device labeling instructions .....	11

Author: S. Maier / 17.02.02



## 1 Scope of delivery

Module  
HF cable  
Antenna

Check that all components are undamaged and that all package contents are present

## 2 Intended use

The “X1310-ISM-Transceiver-915MHz” module is a radio module for data transmission in the ISM band (SUB-GHz range) with the transceiver assembly CC1310 from TI. This module is intended for the frequency range 902.000 – 928.00MHz.

Do not use the system in explosive areas.

Please observe all national regulatory requirements for wireless devices.

The supplied components are intended exclusively for use with this module.



**NOTE**

**This device complies with Part 15 of the FCC Rules. Operation is subject to the following two conditions:**

- (1) This device may not cause harmful interference, and**
- (2) This device must accept any interference received, including interference that may cause undesired operation.**



**NOTE**

**Changes or modifications not expressly approved by the party responsible for compliance could void the user's authority to operate the equipment.**



**NOTE**

**This device complies with Industry Canada's licence-exempt RSSs. Operation is subject to the following two conditions:**

- (1) This device may not cause interference; and**
- (2) This device must accept any interference, including interference that may cause undesired operation of the device**



**NOTE**

**Le présent appareil est conforme aux CNR d'Industrie Canada applicables aux appareils radio exempts de licence. L'exploitation est autorisée aux deux conditions suivantes :**

- 1) l'appareil ne doit pas produire de brouillage;**
- 2) l'utilisateur de l'appareil doit accepter tout brouillage radioélectrique subi, même si le brouil-lage est susceptible d'en compromettre le fonctionnement.**



### 3 Handling

 **Read all instructions first before using the module!**

 **Do not drink any alcohol or take any drugs while using the module and follow the safety instructions carefully!**

 **The utilization of non-approved components can lead to the destruction of the device.**

### 4 Installation of the components

The printed circuit board is attached to the four fixing holes in the application.  
The associated HF cable (length 100mm) is fixed to the application housing using the SMA socket and the associated fixing nut. One of the approved antennas (see Chap 5.4) is screwed onto the SMA socket.  
The HF cable's U.FL connector is inserted onto the X4 connector on the printed circuit board.  
The printed circuit board is connected to the host system via the X1 or X2 connector.

 **Unintended use of the interfaces should be avoided.**

 **All components must be disposed of properly at the end of their technical lifetime.**

#### 4.1 Example for installation

The SMA connector has to be mounted on top of a ground plane. The antenna has to be mounted on the SMA connector.

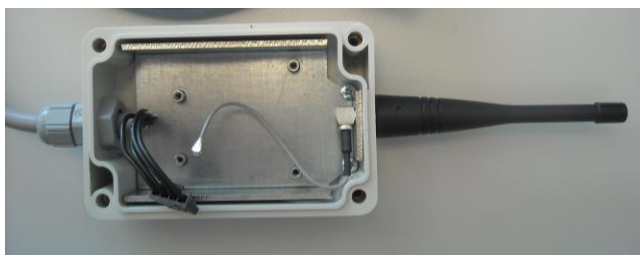



## 5 Module description

### 5.1 Introduction

The “X1310-ISM-Transceiver-915MHz” module is a radio module for data transmission in the ISM band (SUB-GHz range) with the transceiver assembly CC1310 from TI. This module is intended for the frequency range 902.000 – 928.00MHz.

#### 5.1.1 Printed circuit board/module

Printed circuit board material	FR4
HF socket	U.FL (MCX)
Interface	RS232 (X1 / 4-pin); (X2 / 12-pin)
Internal status indicator	1 LED red/green (not assembled)
External status indicator	2 TTL outputs (transmit/receive)
Printed circuit board dimensions	46.23 x 45.47 x 15 mm (LxWxH)
Fixing	4 bore holes
Weight	Approx. 50 g

#### 5.1.2 Environmental conditions

Air humidity	0% – 95%, not condensing
Operation temperature range	-30 °C to +70 °C
Storage temperature	-30 °C to +85°C

#### 5.1.3 System

Transceiver type/MCU	CC1310 ARM Cortex-M3 (TI)
Firmware/radio protocol	Proprietary ACD radio protocol
Memory integrated	64kB Flash (up to 128k possible)
Interface	RS232; RxD, TxD, RTS, CTS
Internal status indicator	1 LED red/green (not assembled)
External status indicator	2 TTL outputs (transmit/receive)
HF output power	Approx. -10dBm to -12dBm
Sensitivity/transmission rate	-110dBm / 19.2kBaud
Modulation	GFSK
Power supply	+4 to +15Vdc, typ. 12mA (<25mA)
Approvals	USA/Canada FCC15.249.a; FCC-ID

### 5.2 Assembling the PCB module

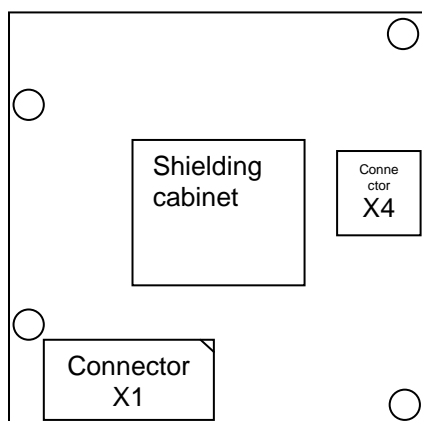

Assembling on the component side

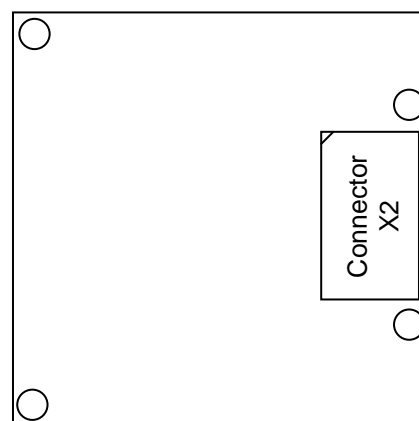

Assembling on the solder side



### 5.3 Pin assignment and designation

#### 5.3.1 X1 connector assignment (host interface)

Connector: 2-1445052-4 TE connectivity

Suitable mating connector: MOLEX 43645-0400 (connector) or suitable alternatives  
MOLEX 43030-001 (crimp contacts)

Pin number	Description
1	TxD (RS232)
2	RxD (RS232)
3	GND
4	+12V

#### 5.3.2 X2 connector assignment (host interface)

Connector: 114712 Erni

Suitable mating connector: 114712 Erni

Pin number	Description
1	+3.3V
2	nc
3	LED_RX
4	LED_TX
5	nc
6	RTS (RS232)
7	TxD (RS232)
8	Nc
9	GND
10	CTS (RS232)
11	RxD (RS232)
12	+12V

#### 5.3.3 X4 connector (HF cable/antenna connection)

Connector: U.FL-R-SMT(01) Hirose or 73412-0110 Molex

#### 5.3.4 HF cable

HF cable: K-2439-02 IMS Connector Systems or suitable alternatives

### 5.4 Antennas

The transceiver may only be operated with the two antennas listed below, as this would otherwise not comply with the approval!

Antenna 1: CTA 915/0/WS/SM/H1 COMPOTEK

or

Antenna 2: CTA 920/0/WR/SM/W1 COMPOTEK



## 6 Functional description

The data to be sent is transmitted from the host via the RS232 interface to the “X1310-ISM-Transceiver-915MHz” module and then GFSK modulated and transmitted by this module via the transmission level and antenna to a receiver module of the same type.

This module is intended for the frequency range 902.000 – 928.00MHz.

The frequency range is divided into 32 channels with a respective channel spacing of 750KHz (see Chap.7: USA/Canada frequency table 915MHz).

The module can be configured via the RS232 interface using commands (see Chap. 6.2: Control commands in command mode, or Chap. 6.3: Control commands in data mode).

### 6.1 Control commands and telegrams

Firstly, a common frequency from the frequency table in Chap. 7 is defined for all radio devices.

The host checks whether the radio channel is available (LBT, Listen Before Talk). If this condition is met, data or acknowledgement telegrams are transmitted, after a random delay, via the RS232 interface to the X1310 transceiver, starting with an <STX>, followed by the <Data> and ending with an <ETB>. Based on the <STX> received, the transceiver now switches on the HF carrier and, first of all, transmits a preamble and SYNC sign. The sequence previously received via the interface is then sent <STX>, <Data>, <ETB>. The <ETB> switches the HF carrier off again in the end.

The length of a telegram is limited by the settable transmission timeout (see “Control commands in command mode” table under STO1..99) in order to not block the remaining infrastructure.

The function is as follows on the receiving side: The receiver in X1310 continuously searches for the SYNC signs. If detected, the data received below is transmitted via the RS232 interface to the host up to the <ETB>. If determined that the HF carrier is interrupted, the receipt is also terminated.

The RF signal is GFSK modulated with a frequency deviation of  $\pm 14$  kHz and a data rate of 19.2 kbit/s. The modulation parameters are fully determined by the internal register settings of the CC1310 radio IC and are independent on the signal at the interface.

Together with the antennas listed in the user manual (5.4), the transmission power is below the limits given under §15.249 of CFR47.

### 6.2 Control commands in command mode

After a reset, the set baud rate is output on the interface at 38400,N,8,1.

You can enable command mode using the sequence +++.

Command word	(Version firmware 2.01)
SWV?	Returns the module's firmware version.
KAN?	Channel query. Returns the set radio channel ( <i>default K16</i> ).
KAN1..32	Channel setting. Sets the desired radio channel.
SDL?	Transmission power query
SDL1..31	Transmission power setting (dummy command), no change due to compatibility matters.
RES	Reset radio module.
BDC?	COM baud rate query. Returned value is the set baud rate ( <i>default 38.4</i> ).
BDC1.2,2.4,4.8,9.6,19.2,38.4,57.6	Setting the COM baud rate. Example: BDC38.4 sets the baud rate to 38400,N,8,1 ( <i>default</i> )
BDF?	Radio baud rate query. ( <i>default 19.2k</i> ).
BDF1.2,2.4,4.8,9.6,19.2,38.4,57.6	Setting the radio baud rate (dummy command), no change due to compatibility matters.
DEF	Setting the default values. Returned value OK.
DEF?	Displaying the default values.



CFG?	Displaying the configuration
FSM0..1	Field strength measurement. FSM0: Field strength measurement off. FSM1: Field strength measurement on.
FSM?	Query whether field strength measurement is on or off.
STO1..99	Setting the transmission timeout in 100ms steps. (default 3s / max.9.9s)
STO?	Returns the set transmission timeout.
RSP0..9	Setting the squelch.
RSP?	Returns the set squelch.
SAV	Saving the setting.
HELP	List of the command words
EXIT	Leave command mode. Command mode is left after a timeout (1min).

### 6.3 Control commands in data mode

The configuration can also be performed in data mode using control telegrams.

<SOH><Command word><Command word><EOT>.

Example: Channel query

<SOH>KAN?<EOT>      return: <SOH>KAN8<EOT>

Example: Set channel to channel 12:

<SOH>KAN12<EOT>      return: <SOH>KAN12<EOT>

### 6.4 Data telegram

LBT applies (Listen Before Talk).

<STX><Header><Data><ETB>

STX switches the transmitter on

ETB switches the transmitter off

### 6.5 Acknowledgement telegram

A data telegram is acknowledged by an acknowledgement telegram.

LBT applies (Listen Before Talk).

<STX><Header><Acknowledgement><ETB>

STX switches the transmitter on

ETB switches the transmitter off





## 7 USA/Canada frequency table 915MHz

Channels 32 Channel spacing: 750KHz.		Transmission power		
		SDLx	dBm	Power $\mu$ W/mW
Channel 1:	903.500MHz	1	-12dBm	63 $\mu$ W (def.)
Channel 2:	904.250MHz	2	-12dBm	63 $\mu$ W
Channel 3:	905.000MHz	3	-12dBm	63 $\mu$ W
Channel 4:	905.750MHz	4	-12dBm	63 $\mu$ W
Channel 5:	906.500MHz	5	-12dBm	63 $\mu$ W
Channel 6:	907.250MHz	6	-12dBm	63 $\mu$ W
Channel 7:	908.000MHz	7	-12dBm	63 $\mu$ W
Channel 8:	908.750MHz	8	-12dBm	63 $\mu$ W
Channel 9:	909.500MHz	9	-12dBm	63 $\mu$ W
Channel 10:	910.250MHz	10	-12dBm	63 $\mu$ W
Channel 11:	911.000MHz	11	-12dBm	63 $\mu$ W
Channel 12:	911.750MHz	12	-12dBm	63 $\mu$ W
Channel 13:	912.500MHz	13	-12dBm	63 $\mu$ W
Channel 14:	913.250MHz	14	-12dBm	63 $\mu$ W
Channel 15:	914.000MHz	15	-12dBm	63 $\mu$ W
Channel 16:	914.750MHz (def.)	16	-12dBm	63 $\mu$ W
Channel 17:	915.500MHz	17	-12dBm	63 $\mu$ W
Channel 18:	916.250MHz	18	-12dBm	63 $\mu$ W
Channel 19:	917.000MHz	19	-12dBm	63 $\mu$ W
Channel 20:	917.750MHz	20	-12dBm	63 $\mu$ W
Channel 21:	918.500MHz	21	-12dBm	63 $\mu$ W
Channel 22:	919.250MHz	22	-12dBm	63 $\mu$ W
Channel 23:	920.000MHz	23	-12dBm	63 $\mu$ W
Channel 24:	920.750MHz	24	-12dBm	63 $\mu$ W
Channel 25:	921.500MHz	25	-12dBm	63 $\mu$ W
Channel 26:	922.250MHz	26	-12dBm	63 $\mu$ W
Channel 27:	923.000MHz	27	-12dBm	63 $\mu$ W
Channel 28:	923.750MHz	28	-12dBm	63 $\mu$ W
Channel 29:	924.500MHz	29	-12dBm	63 $\mu$ W
Channel 30:	925.250MHz	30	-12dBm	63 $\mu$ W
Channel 31:	926.000MHz	31	-12dBm	63 $\mu$ W
Channel 32:	926.750MHz			

Frequency band: 902.000 – 928.00MHz  
 Transmission power: approx.-12dBm  
 Channel raster: 750 kHz  
 Duty cycle: no limits



## 8 Service and spare parts

If you have service requests, or require spare parts, please contact:

### **ACD Elektronik GmbH**

Engelberg 2

88480 Achstetten

Germany

Telephone: +49 7392 708 499

Fax: +49 7392 708 490

Email: [info@acd-elektronik.de](mailto:info@acd-elektronik.de)

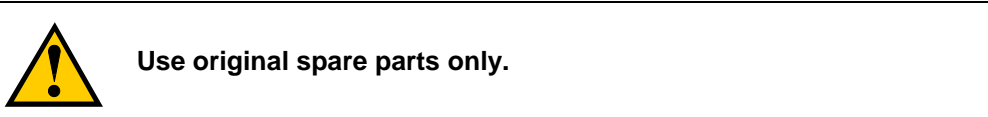



## 9 RSS COMPLIANCE STATEMENT

This device complies with Industry Canada's licence-exempt RSSs. Operation is subject to the following two conditions:

- (1) This device may not cause interference; and
- (2) This device must accept any interference, including interference that may cause undesired operation of the device

Le présent appareil est conforme aux CNR d'Industrie Canada applicables aux appareils radio exempts de licence. L'exploitation est autorisée aux deux conditions suivantes :

- 1) l'appareil ne doit pas produire de brouillage;
- 2) l'utilisateur de l'appareil doit accepter tout brouillage radioélectrique subi, même si le brouillage est susceptible d'en compromettre le fonctionnement.

## 10 End device labeling instructions

FCC notes for all hosts devices. The end device must be labeled with:

Contains FCC ID: O2F-X1310TC915"

Contains IC: 9137A-X1310TC915



Labelling Requirements

In addition following statement shall be placed on the device:



**This device complies with Part 15 of the FCC Rules. Operation is subject to the following two conditions: (1) this device may not cause harmful interference, and (2) this device must accept any interference received, including interference that may cause undesired operation.**

Where the product is so small or for such use that it is not practicable to place the statement on it, the statement can be placed in a prominent location in the instruction manual.

#### Information to the user

- For Class A devices the manual of the host shall include the following statement:

NOTE: This equipment has been tested and found to comply with the limits for a Class A digital device, pursuant to part 15 of the FCC Rules. These limits are designed to provide reasonable protection against harmful interference when the equipment is operated in a commercial environment. This equipment generates, uses, and can radiate radio frequency energy and, if not installed and used in accordance with the instruction manual, may cause harmful interference to radio communications. Operation of this equipment in a residential area is likely to cause harmful interference in which case the user will be required to correct the interference at his own expense.

- For Class B devices the manual of the host shall include the following statement:

Note: This equipment has been tested and found to comply with the limits for a Class B digital device, pursuant to part 15 of the FCC Rules. These limits are designed to provide reasonable protection against harmful interference in a residential installation. This equipment generates, uses and can radiate radio frequency energy and, if not installed and used in accordance with the instructions, may cause harmful interference to radio communications. However, there is no guarantee that interference will not occur in a particular installation. If this equipment does cause harmful interference to radio or television reception, which can be determined by turning the equipment off and on, the user is encouraged to try to correct the interference by one or more of the following measures:

- Reorient or relocate the receiving antenna.
- Increase the separation between the equipment and receiver.
- Connect the equipment into an outlet on a circuit different from that to which the receiver is connected.
- Consult the dealer or an experienced radio/TV technician for help.

#### Modification of equipment

The instruction manual of the host shall include the following statement: Changes or modifications made to this equipment not expressly approved by the party responsible for compliance may void the FCC authorization to operate this equipment.

#### Special accessories

Where special accessories such as shielded cables and/or special connectors are required to comply with the emission limits, the instruction manual shall include appropriate instructions on the first page of the text describing the installation of the device.

#### Final Compliance of end product

The integrator is responsible for the final compliance of the end product including this certified transmitter module. CFR 47 §15.101 give guidance in terms of applicable equipment authorization procedures of different end-products. Typically compliance to subpart 15 B (§15.107 and 15.109) Class A or B including verification of the subpart 15 C compliance (field strength of fundamental and out-of-band emissions) of the transmitter parameters apply.



## Simultaneous transmission

When the host product supports simultaneous-transmission operations the host manufacturer needs to check if there are additional RF exposure filing requirements due to the simultaneous transmissions. When additional application filing for RF exposure compliance demonstration is not required (e. g. if the X1310-ISM-Transceiver-915MHz module in combination with all simultaneously operating transmitters complies with the RF exposure simultaneous transmission SAR test exclusion requirements), the host manufacturer may do his own evaluation without any filing, using reasonable engineering judgment and testing for confirming compliance with out-of-band, restricted band, and spurious emission requirements in the simultaneous-transmission operating modes.

If additional filing is required please contact the person at ACD Gruppe responsible for certification of the X1310-ISM-Transceiver-915MHz module.