

# **UDR-S100/S400 Portable Radio**

## **Digital Mobile Radio**

### **User Manual**

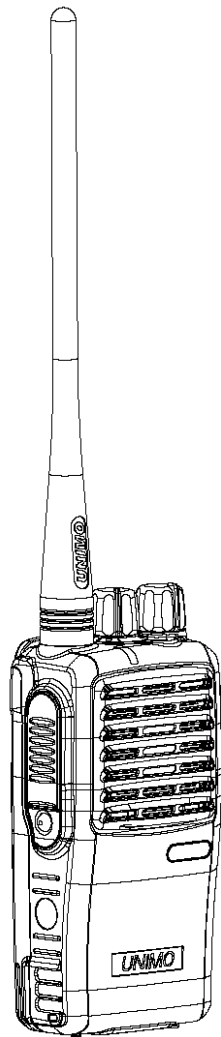

**UNIMO** Technology Co.,Ltd.

## ※ Understanding the Product

- ♣ sure to read and understand the user manual before using this equipment.
- ♣ Features may be changed without prior notice to improve product performance.
- ♣ The copyright of the user manual belongs to UNIMO Technology Co., Ltd., and unauthorized reproduction in whole or in part is prohibited.
- ♣ Screens and pictures in the user manual may differ from the actual product.
- ♣ If you have any questions about the contents of the user manual, please contact our dealer or A/S.

### Matters affecting the operation of radios or other devices

Because radios generate strong radio waves and detect weak radio waves, the operation of other electronic devices may be affected or affected.



Turn off your radio when boarding the aircraft. When using it, follow the rules of the aircraft or the instructions of the flight attendant.



Before using medical equipment, check with the medical equipment manufacturer or doctor in charge to determine whether electromagnetic waves are affected.



Avoid using it near various electrical and electronic devices, such as computers. The strong radio waves from the radio may cause damage to electrical and electronic devices.

※ Electronic and electrical devices generate various electromagnetic waves. The effects of these electromagnetic waves may occasionally cause unwanted reception. Example) Fluorescent lights, computers, monitors, vending machines, etc.

### Safety precautions

The following information provides guidance and instructions for the safe and effective use of your UNIMO radio. Please be sure to read it.



When using a walkie-talkie, keep it at least 1 inch (2.5 cm) away from your body.



The antenna coating may be damaged and cause burns if it touches the skin.



If a conductive metal (key, necklace, etc.) touches the battery terminal, heat may be generated and burns may occur. Be especially careful when storing batteries in pockets or bags.



If you want to use it while driving, check if there are any regulations regarding the use of radios while driving and refrain from using them as much as possible. You can reduce the risk by using separate accessories such as an ear/microphone



Do not listen at too high a volume. This may affect your hearing.



When using in an explosion hazard area, only devices that have passed the explosion proof test can be used. Do not remove, replace, charge or discharge the battery within the hazard zone. Electrical sparks may cause burns or death.



Turn off the radio near workplaces where electromagnetic explosions occur.

## 1 PRODUCT FEATURES

The UDR-E Series terminal is a European standard DMR type digital walkie-talkie that uses AMBE+2 vocoder to provide optimized sound quality and noise-free voice quality regardless of distance. It is also designed to have a light and sturdy structure and provides powerful sound. The UDR-Series terminal is designed to provide sufficient services to users in industrial sites and public safety, and when used, calls can be made with perfect security and clear sound quality.

UDR-Series terminals can be provided with various optional specifications. The terminal can be programmed with a personal computer using a phone jack and a separate program cable.

- DMR(Digital Mobile Radio)/Analog Transceiver
- Frequency : VHF(136~174Mhz)/UHF(400~470Mhz)
- Channel Spacing : 12.5KHz/25KHz
- 16 Channel Selection
- Transmission Output(2W/5W)
- TX Intercept
- Encryption AES256
- Individual call, Group call, All call Functions
- Wired and Wireless Cloning
- USB PC Programming(CPS)
- 7.4V/2,600mAh large capacity battery
- Waterproof(IP67 & IP54)

## 2 COMPONENTS

### 2.1 Basic Components

- Transceiver .....1EA
- 7.4V, 2,600mAh lithium-ion battery .....1EA
- Antenna .....1EA
- Quick Charger .....1EA
- AC110~220V/DC12V Adapter .....1EA
- User manual .....1EA
- UDR Wrist strap .....1EA

### 2.2 Optional components

- Leather case
- Antenna
  - . Helical Antenna
  - . Stubby Antenna
- Regular Ear-Microphone
- Security Ear-Microphone
- Hand Speaker-Microphone
- Cloning Cable
- USB PC program cable(for CPS)
- 1-Prong charger , 2-Prong charger

\* Components may change upon request.

### 3 NAME AND EXPLANATION OF EACH PART

The following is a description of the UDR-E series transceiver operation and display functions.

Detailed operation instructions are provided in the next chapter.

#### 3.1 Description of each part

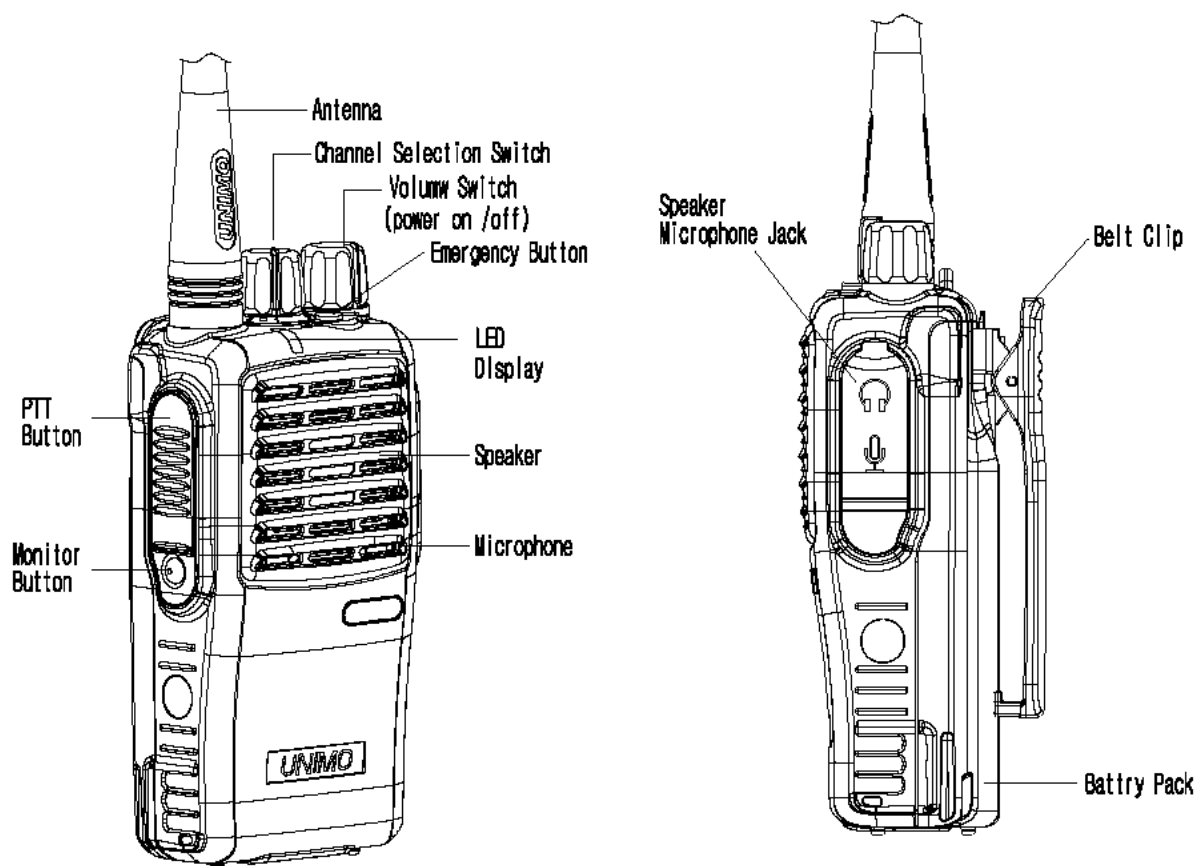

### **Power ON/OFF Volume Variable**

If you slowly turn the volume switch clockwise, the device turns on and the volume gradually increases. If you turn it counterclockwise, the volume decreases and the power turns off.

### **Channel Change Switch(encoder)**

Wireless channels must be programmed into the terminal in advance using a CPS program, and a total of 1024 channels can be entered and selected. When the channel selection switch is turned clockwise, the programmed channel changes one step at a time to the next channel (direction of increasing channel number), and when turned in the opposite direction, it changes one step at a time to the previous channel (direction of decreasing channel number). This channel change is possible at the same interval even by using the button set for channel change..

### **PTT(Transmit) button**

When you press the largest PTT button located on the side of the terminal, the terminal changes to transmission mode and transmits a wireless signal using a pre-programmed channel and transmission output. When you release the PTT button, the terminal stops transmitting and enters the receiving standby state..

### **Monitoring button(Analog-only function)**

Use the monitor button to check the reception status of the set channel.

Continuous mode: If you press the monitor button within about 2 seconds, you can continuously check the reception status of the channel with a noise and a “beep” tone. If you press the monitor button again, the monitor function will be canceled and the terminal will be in a reception standby state..

### **Emergency button**

If an emergency situation occurs according to a preset function, if you press the red emergency button on the top of the main unit, the terminal emits an emergency siren sound through its own speaker. At the same time, an emergency signal is transmitted through the emergency channel.



## EXT Speaker & Microphone Jack

You can connect and use external accessories (external speaker & microphone, earphones, et c.) through the speaker & microphone jack located on the side of the terminal. Terminal programming is possible using a CPS program cable or cloning cable.

## 3.2 Status Display

### Status LED

Users can recognize the current status of the terminal through the status display LED located at the top of the terminal. The status display is as follows

- Red LED on: Transmitting.
- Green LED on: Receiving.
- Blinking Red LED: Low Battery Level.

## 4 BASIC OPERATION METHOD

### 4.1 Power ON/OFF

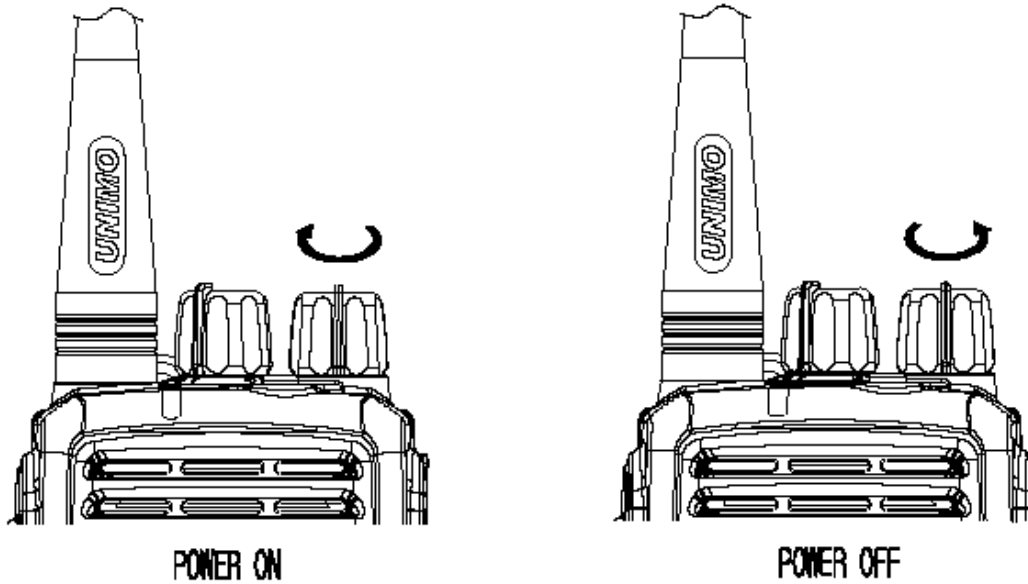

- Turn the power/volume switch clockwise to turn it on.
- Turn the power/volume switch counterclockwise until you hear a tick to turn it off.

## 4.2 Attaching and Removing Antenna

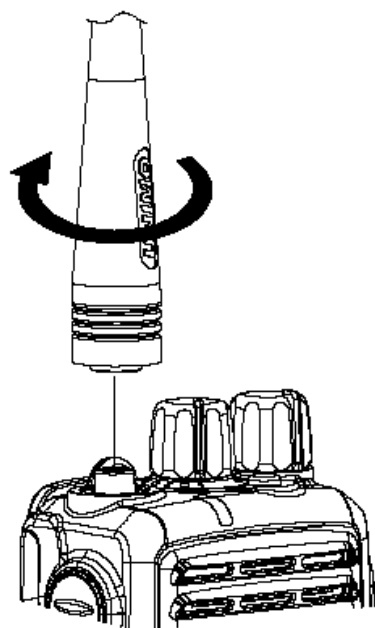

Antenna Assembly

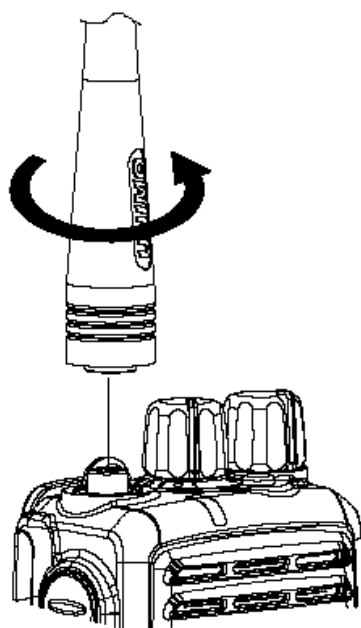

Antenna Disassembly

- To separate and attach the antenna, attach the antenna to the antenna connector of the main body and turn it clockwise to connect the antenna. Turn it counterclockwise to disconnect the antenna..



Caution `

When connecting the antenna, be careful not to apply excessive force or pull the antenna as the antenna connector may be damaged.

### 4.3 Install and Remove Battery

#### Battery Installed

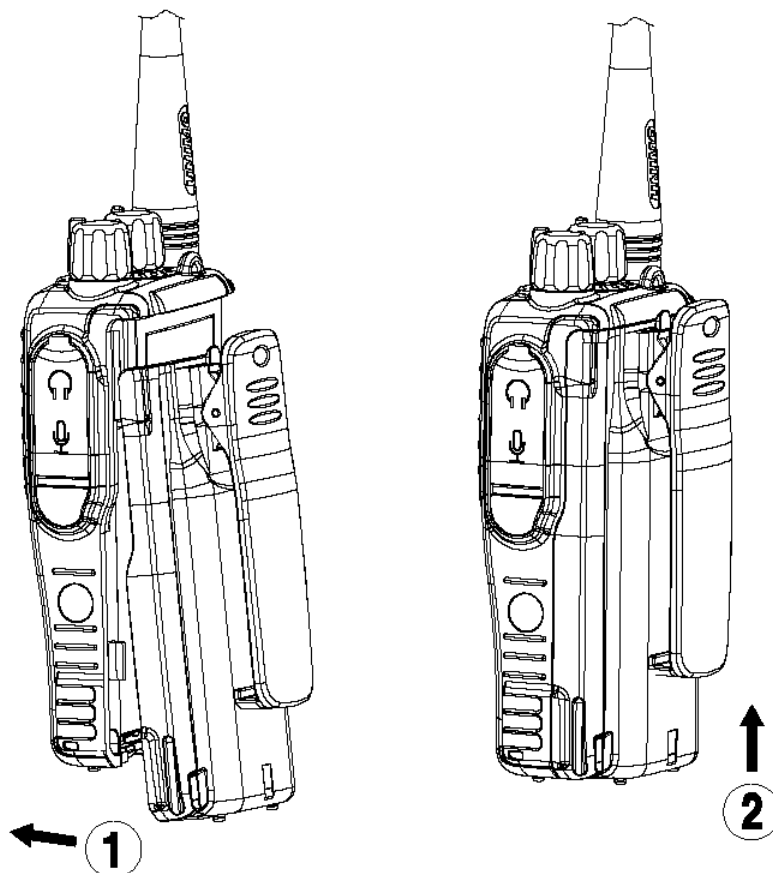

- Turn off the main unit.
- Hold the main unit and battery in both hands so that the back is visible.
- Align the hooks on the back of the main body with the hooks on the front of the battery.
- While pressing the bottom of the battery, slide the battery upward until it clicks into place.
- Make sure the battery lock is in the normal position.

## 4.4 Removed Battery

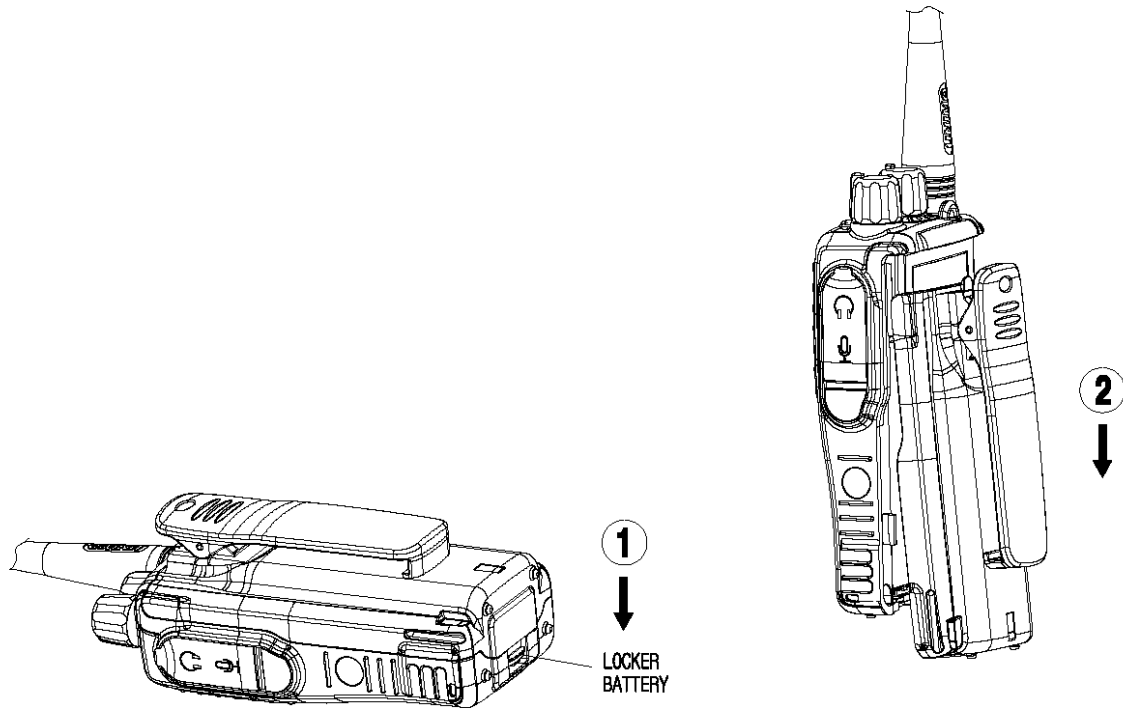

- Turn off the main unit.
- Hold it in both hands so that the back of the body and battery are visible.
- While pressing down on the locking device, gently slide the battery downward to remove it from the main body.

#### 4.4 Installing and removing the battery belt clip

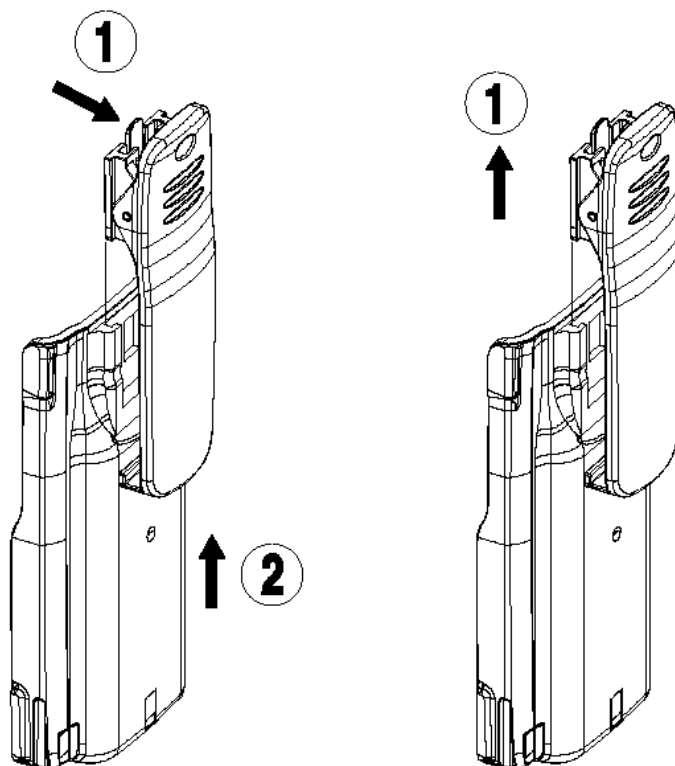

- Belt clip removal -

- Belt clip attached -

- Remove the belt clip from the battery by lifting the locking device located on the top of the belt clip and sliding the belt clip upward.
- The battery belt clip is installed by aligning the belt clips in the grooves of the battery and pushing the belt clip down until you hear a 'click' sound..

## 4.5 Charge the Battery

Lithium-ion battery used in the UDR-Series is a battery with high stability and reliability. To maintain optimal capacity and stable operation of the terminal, be sure to fully charge the battery before use.

## 4.6 When to Charge the Battery

Charge new batteries or batteries that have been left unattended for a long time before using the equipment. If the battery voltage drops, the communication distance becomes shorter and the device cannot operate to its full potential. Please charge in the following situations.

- When performance is judged to have decreased after approximately 10 to 13 hours of use.
- When charging a radio with a battery, turn it off completely and then insert it into the charger.
- There are two types of chargers: 1-prong and 2-prong. In the case of the 2-prong charger, the front slot can be used to charge while attached to the UDR-Series terminal, and the rear slot can only charge the battery..
- Even if the green lamp lights up after charging is complete, perform supplementary charging for about 30 minutes to fully charge.

Operating status	LED Color
Charging	Red LED lights ON
Charging complete	Green LED lights ON
Bad battery	Red LED flashing
Temperature out of range, Rear slot waiting for charging	Yellow LED flashing



The charger must be a genuine product provided by UNIMO Technology Co., Ltd.

#### 4.7 Precautions when charging

- The battery is designed to be used only with our dedicated charger, and we are not responsible for any problems arising from the use of a third-party charger.
- When charging the battery while it is installed in the terminal, the terminal must be turned off and charged for full charging..
- There is a risk of fire or explosion if the user arbitrarily disassembles or shorts it.
- Be careful because if the battery terminal touches a metal or conductor, it may damage the object or cause injury to the human body.
- Do not charge the battery near fire or place it in direct sunlight.
- If the charger's LED flashes yellow during charging, it indicates a defect in the battery pack, so be sure to contact your dealer.



## 5 FUNCTION DESCRIPTION

### 5.1 Power On/Off

Power is supplied by turning the power switch clockwise, a “beep beep” sound will be heard and a message informing you of the current channel will appear. From this point on, the terminal can operate normally.

### 5.2 Transmission

Press the PTT button on the side of the transmitting terminal, the red LED turns on and voice is transmitted. For best sound quality, it is recommended to maintain a distance of 5 to 10 cm.

### 5.3 Receiver

Use the volume switch to adjust the volume, and in normal reception status, the top lamp lights up in green. The frequency is the same, but if the reception is not normal, the green lamp blinks..

### 5.4 Change Channel

Channel switch is used to change channels. The channel number is written on the side of the switch, and a channel guidance sound is heard each time the channel is changed.

If you are placed on a channel that has not been assigned a frequency, a continuous beep will sound and both transmission and reception will be restricted..

### 5.5 Change Transmission Output

Transmission output can be selected as high output or low output mode. In a good communication environment, you can extend battery usage time by changing to low output mode. High output displays a red LED, and low output displays a yellow LED.

The transmission output mode can be set in advance using the CPS program, and can be changed by the user with the set button..

## 5.6 VOX Function

VOX function allows you to transmit using the voice signal input into the microphone without pressing PTT. You can set it in advance using the CPS program and use it with the set button.

## 5.7 Monitoring Function (Analog 기능)

To force open Squelch, press the Monitor button. To exit this mode, press the monitor button again or cycle the power.

This function can only be used on analog channels.

## 5.8 Sub Tone Function (Analog function)

Set the CPS program to include a CTCSS tone or DCS code for each wireless channel.

### 5.8.1 CTCSS Tone

CTCSS Subtone frequencies refer to the table below

No.	Frequency	No.	Frequency	No.	Frequency	No.	Frequency
1	67.0	15	110.9	29	179.9	43	196.6
2	71.9	16	114.8	30	186.2	44	199.5
3	74.4	17	118.8	31	192.8	45	206.5
4	77.0	18	123.0	32	203.5	46	229.1
5	79.7	19	127.3	33	210.7	47	254.1
6	82.5	20	131.8	34	218.1	48	165.5
7	85.4	21	136.5	35	225.7	49	171.3
8	88.5	22	141.3	36	233.6	50	177.3
9	91.5	23	146.2	37	241.8		
10	94.8	24	151.4	38	250.3		
11	97.4	25	156.7	39	69.3		
12	100.0	26	162.2	40	159.8		
13	103.5	27	167.9	41	183.5		
14	107.2	28	173.8	42	189.9		

### 5.8.2 DCS Code

DCS Code frequencies refer to the table below

No.	DCS Code	No.	DCS Code	No.	DCS Code	No.	DCS Code
1	023	27	165	53	413	79	731
2	025	28	172	54	423	80	732
3	026	29	174	55	431	81	734
4	031	30	205	56	432	82	743
5	032	31	223	57	445	83	754
6	043	32	226	58	464	84	036
7	047	33	243	59	465	85	053
8	051	34	244	60	466	86	122
9	054	35	245	61	503	87	145
10	065	36	251	62	506	88	212
11	071	37	261	63	516	89	225
12	072	38	263	64	532	90	246
13	073	39	265	65	546	91	252
14	074	40	271	66	565	92	255
15	114	41	306	67	606	93	266
16	115	42	311	68	612	94	274
17	116	43	315	69	624	95	325
18	125	44	331	70	627	96	332
19	131	45	343	71	631	97	356
20	132	46	346	72	632	98	446
21	134	47	351	73	654	99	452
22	143	48	364	74	662	100	454
23	152	49	365	75	664	101	455
24	155	50	371	76	703	102	462
25	156	51	411	77	712	103	523
26	162	52	412	78	723	104	526

## 5.9 Digital(DMR) Call Mode

### 5.9.1 Individual calls

Select a channel set with an individual ID, one-to-one communication is performed with the terminal with the correct ID.

Setting the frequency for each channel in the CPS program, it must be set in advance.

The receiver receives if the received ID is the same as MY ID.

### 5.9.2 Group Call

Select a channel set as a group ID, you will make a call with the terminals included in the corresponding group.

Setting the frequency for each channel in the CPS program, it must be set in advance.

The receiver receives if the received group ID matches my group list..

### 5.9.3 All Call

select a channel set to Global ID, calls will be made to all terminals.

When setting the frequency for each channel in the CPS program, it must be set in advance.

All receivers on the same frequency will receive it.

## 5.10 TOT Setting

Used to block specific users from occupying the channel for a long period of time. When you press the PTT button, if transmission exceeds the preset time, transmission will stop and a warning tone will sound. If a penalty time is set, normal transmission occurs after that time. Can be set in advance using the CPS program.

## 5.11 PSC(Power Saving) Setting

Set it in advance using the CPS program, it automatically turns the power on/off during reception standby time and reduces battery consumption.

## 5.12 Squelch Level Setting

CPS program, you can set the squelch level in 3 levels in advance.

### 5.13 Cloning

CLONING is a function that copies the channel information of one radio to another radio. Items to be duplicated can be frequency channels/tones/SCAN, etc. Cloning function only supports wired method.

#### 5.13 Wired Cloning

- We prepare cloning cables exclusively for the UDR-Series manufactured by our company.
- Turn on the original radio by pressing the monitor button on the side (orange LED), and keep the clone radio in standby mode.
- Connect the cloning cable to the Ear/Mic Jack of both radios.
- Cloning starts when you press the monitor button on the source terminal.
- After removing the cable, power cycle both radios. After confirming that cloning was successful, use the terminal.

### 5.14 Emergency Call Function

Press the emergency button, an emergency alarm sounds and an emergency bell is transmitted to the currently located channel. If the repeat mode is set, an emergency bell will be sent periodically (to cancel the repeat, press the emergency button again).

Set it in advance using the CPS program.

### 5.15 Lone Worker

If there is no user operation for a set period of time, an alarm is repeatedly sent at the given time.

Set it in advance using the CPS program.

## 5.18 License Options

This item can be used by adding additional options in addition to the common functions.

### 5.18.1 Encryption

This is a function that encrypts the call contents to prevent third parties from listening to them.

. ARC4: 40bit encryption function, and up to 10 digits can be specified for encryption.

. AES: Encryption possible in 128bit, 192bit, 256bit. Up to 30 encryption keys can be stored.

Can be set in advance using the CPS program

### 5.18.2 TX Intercept

This function stops communication of all radios transmitting/receiving on the same channel and allows radios with interception rights to transmit first. Interception can only be set to one radio, and this function is only available between Unimo radios. You can use the interception function by setting it in the CPS program. (Both the interception permission and the target radio must be set)

## 6 사양(SPECIFICATION)

### 6.1 MODEL: UDR-S100

#### GENERAL

Dimensions(Less Antenna) H x W x D	102.4 × 53mm × 32.5 mm
Weight	
Radio (less battery)	117.7g
with battery (2600mAH)	268.2g
Programmable Channels	1024 Channels
Channel Spacing	12.5(Digital)/12.5,25(Analog)kHz
Power Source	7.5V DC Rechargeable Li-ion 2600 mAH battery pack
Current Drain (maximum)	
Receive Standby mode	70 mA
Receive Full Audio	420 mA
Transmit at 5 Watts	1.7 A

#### TRANSMITTER

Frequency Range	136 ~ 174 MHz
Frequency Stability	±2.5 ppm (-30 to +60℃)
RF Power Output	5 Watts / 2 Watts
Spurious and Harmonic	-36dBm<1GHz, -30dBm>1GHz
FM Hum and Noise	40dB
Audio Distortion	5% maximum
Audio Frequency Response	+1, -3dB from 6dB per octave pre-emphasis Characteristic from 300 ~ 3000Hz

#### RECEIVER

Frequency Range	136 ~ 174 MHz
Sensitivity	.25uV 12 dB SINAD
Squelch Sensitivity	.22uV 10 dB SINAD
Selectivity	60dB
Spurious and Harmonic Rejection	70dB
Inter-modulation	60dB
FM Hum and Noise	40dB
Audio Output Power	1 Watt across an 16-ohm load
Audio Distortion	Less than 5% at rated output
Audio Response	+1, -3 dB from 6dB per octave de-emphasis Characteristic from 300 ~ 3000Hz

**6.2 MODEL: UDR-S400**
**GENERAL**

Dimensions(Less Antenna) H x W x D	102.4 × 53mm × 32.5 mm
Weight	
Radio (less battery)	117.7g
with battery (2600mAH)	268.2g
Programmable Channels	1024 Channels
Channel Spacing	12.5(Digital)/12.5,25(Analog)kHz
Power Source	7.5V DC Rechargeable Li-ion 2600 mAH battery pack
Current Drain (maximum)	
Receive Standby mode	120 mA
Receive Full Audio	420 mA
Transmit at 4.8 Watts	1.7 A

**TRANSMITTER**

Frequency Range	400 ~ 470 MHz
Frequency Stability	±2.5 ppm (-30 to +60°C)
RF Power Output	5 Watts / 2 Watts
Spurious and Harmonic	-36dBm<1GHz, -30dBm>1GHz
FM Hum and Noise	40dB
Audio Distortion	5% maximum
Audio Frequency Response	+1, -3dB from 6dB per octave pre-emphasis Characteristic from 300 ~ 3000Hz

**RECEIVER**

Frequency Range	400 ~ 470 MHz
Sensitivity	.25uV 12 dB SINAD
Squelch Sensitivity	.22uV 10 dB SINAD
Selectivity	60dB
Spurious and Harmonic Rejection	70dB
Inter-modulation	60dB
FM Hum and Noise	40dB
Audio Output Power	1 Watt across an 16-ohm load
Audio Distortion	Less than 5% at rated output
Audio Response	+1, -3 dB from 6dB per octave de-emphasis Characteristic from 300 ~ 3000Hz



### 6.3 Battery Pack

The following batteries can be used in UDR-E/S Series terminals..

- PBC-2260W: High capacity battery (2600mAH Li-ion)..

It is safe in any environment and provides high capacity and high reliability.

If you use the standard charger provided by Unimo, you can fully utilize the battery's efficiency and service life.

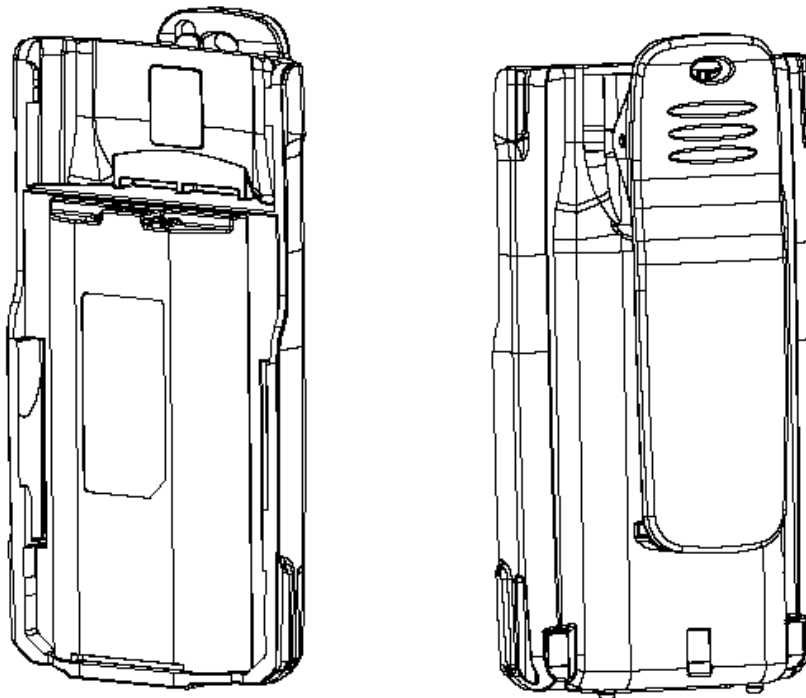

---

You must use genuine batteries provided by Unimo Technology Co., Ltd.

---

## 6.4 Charger Cradle

This is a dedicated charger designed to charge the high capacity Li-ion battery (PBC-2260W) provided by UNIMO.

There is a 1-prong charger (CHNZ-260S) and a 2-prong charger (CHNZ-260DK), and we provide 1-prong or 2-prong chargers depending on the requested option.

### 6.4.1 1-Prong Charger (CHNZ-260S)

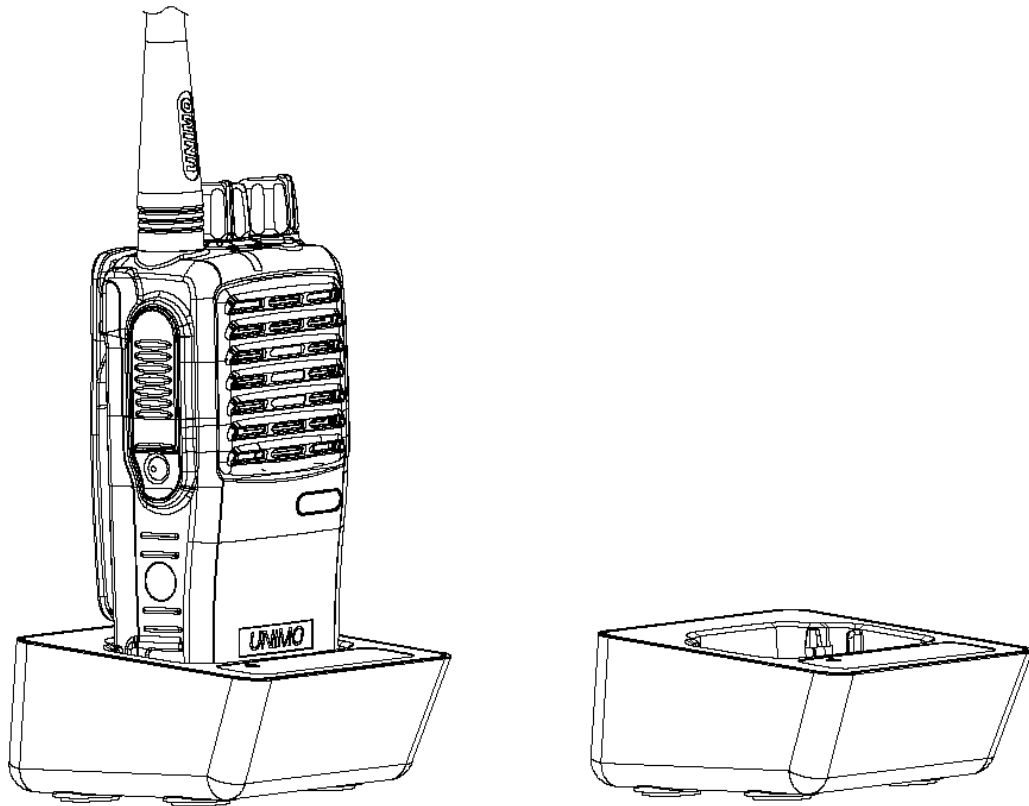

## 6.4.1 2-Prong Charger (CHNZ-260DK)

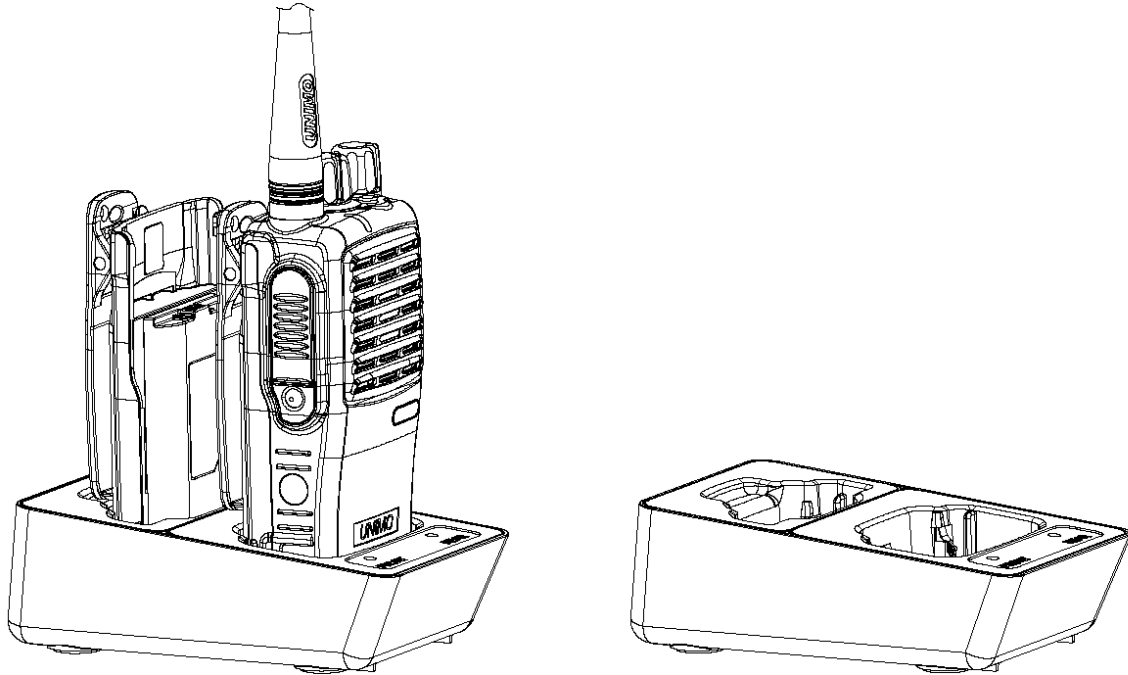

## Charger Specifications

Item	Specifications
Input Voltage	DC 12V $\pm$ 20%
Applicable Battery	PBC-2260W
Charging Time	3시간 30분
Operating Temperature	0 ~ 40°C
Size	135(L) * 87(W) * 50(H)m/m
Charging Current	900 mA

. Address : 6F, Hanshin IT 2nd Tower, 47 Digital-ro 9-gil, Geumcheon-gu, Seoul, Rep ofKorea)

. Tel : +82-2-6710-7000 / Fax : +82-2-6710-7004

. <http://www.unimo.co.kr> / <http://chatterboxglobal.com>

**UNIMO** *Technology Co.,Ltd.*

### **FCC Statement**

This equipment has been tested and found to comply with the limits for a Class B digital device, pursuant to part 15 of the FCC Rules. These limits are designed to provide reasonable protection against harmful interference in a residential installation. This equipment generates, uses and can radiate radio frequency energy and, if not installed and used in accordance with the instructions, may cause harmful interference to radiocommunications, However, there is no guarantee that interference will not occur in a particular installation, If this equipment does cause harmful interference to radio or television reception, which can be determined by turning the equipment off and on, the user is encouraged to try to correct the interference by one or more of the following measures:

- Reorient or relocate the receiving antenna.
- Increase the separation between the equipment and receiver.
- Connect the equipment into an outlet on a circuit different from that to which the receiver is connected.
- Consult the dealer or an experienced radio/Ty technician for help.

**Caution:** Any changes or modifications to this device not explicitly approved by manufacturer could void your authority to operate this equipment.

This device complies with part 15 of the FCC Rules. Operation is subject to the following two conditions: (1) This device may not cause harmful interference, and (2) this device must accept any interference received, including interference that may cause undesired operation.

### **RF Energy Exposure Awareness and Control information and Operational instructions for Occupational Use**

Notice: this radio is intended for use in occupational/controlled conditions where users have full knowledge of their exposure and can exercise control over their exposure to meet the occupational limits in FCC and international standards, This radio device is NOT authorized for general population consumer use,

### **Federal Communication Commission (FCC) Regulations**

When this radio device used as a consequence of employment, the FCC requires users to be fully aware of and able to control their exposure to meet occupational requirement. Exposure awareness can be facilitated by the use of a product label directing users to specific user awareness information. Your radio device has a RF Exposure Product Label. Also, your radio device user manual includes information and operating instructions required to control your RF exposure and satisfy compliance requirements.

### **Compliance with RF Exposure Standards**

Your radio device is designed and tested to compliance with a number of national and international standards and guidelines for human exposure to radiofrequency electromagnetic energy. This radio compliance with the IEEE (FCC) and ICNIRP exposure limits for occupational/controlled RF exposure environments at operating duty factors of up to 50% talk - 50% listen and is approved for occupational use only. in terms of measuring At energy for compliance with these exposure

guidelines, your radio generates measurable RF energy only while it is transmitting (during talking, not when it is receiving (listening or in standby mode).

**Your radio device complies with the following Rf energy exposure standards and guidelines:**

- United States federal Communications Commission (FCC), Code of Federal Regulations;
- Institute of Electrical and Electronic Engineers (IEEE) C95.1
- International Commission on Non-ionizing Radiation Protection (ICNIRP)

**RF Exposure Compliance and Control Guidelines and Operating instructions for Two-Way Radio Operations**

To control your exposure and ensure compliance with the occupational/controlled environment exposure limits, always adhere to the following procedures;

- DO Not remove the RF Exposure Label from the device
- User awareness instructions should accompany device when transferred to other users.

**Operational instructions and Training Guidelines**

To ensure optimal performance and compliance with the occupational controlled environment RF energy exposure limits in the above standards and guidelines users should transmit no more than 50% of the time and always adhere to the following procedures.

- In front of the face, hold the radio in a vertical position with microphone (and other parts of the radio including the antenna) at least one inch (2.5 centimeters) away from the nose or lips. Keep the radio at a proper distance is important to ensure compliance.  
Note: RF exposure decrease with increasing distance from the antenna.
- Body Worn Operation; when worn the body, always place the radio in an approved clip, holder, or body harness for this product. Using approved body\*worn accessories is important because the use of non-approved accessories may result in exposure levels, which exceed the occupational/controlled environment RF exposure limits. Using only approved supplied or replacement antennas, batteries, and audio accessories, use of non-approved antennas, batteries, and wired or wireless accessories may exceed the applicable RF exposure guidelines (IEEE, ICNIRP Or FCC).