



FCC TEST REPORT

For

Unimo Technology Co., Ltd.

UDR-S400

Test Model: UDR-S400

Prepared for : Unimo Technology Co., Ltd.
Address : 6F, Hanshin IT 2nd Tower, 47 Digital-Ro 9-Gil,Gu office 603 Seoul, Rep of Korea 08511 South Korea

Prepared by : Shenzhen LCS Compliance Testing Laboratory Ltd.
Address : 101, 201 Bldg A & 301 Bldg C, Juji Industrial Park Yabianxueziwei, Shajing Street, Baoan District, Shenzhen, 518000, China
Tel : (+86)755-82591330
Fax : (+86)755-82591332
Web : www.LCS-cert.com
Mail : webmaster@LCS-cert.com

Date of receipt of test sample : April 12, 2024
Number of tested samples : 2
Sample No. : A240319050-1, A240319050-2
Serial number : Prototype
Date of Test : April 12, 2024 ~ May 23, 2024
Date of Report : May 24, 2024





FCC TEST REPORT
FCC Part 90

Report Reference No. : LCSA04114110EA

Date of Issue : May 24, 2024

Testing Laboratory Name : Shenzhen LCS Compliance Testing Laboratory Ltd.
Address : 101, 201 Bldg A & 301 Bldg C, Juji Industrial Park Yabianxueziwei, Shajing Street, Baoan District, Shenzhen, 518000, China
Testing Location/ Procedure : Full application of Harmonised standards
Partial application of Harmonised standards
Other standard testing method

Applicant's Name : Unimo Technology Co., Ltd.
Address : 6F, Hanshin IT 2nd Tower, 47 Digital-Ro 9-Gil,Gu office 603 Seoul, Rep of Korea 08511 South Korea

Test Specification

Standard : FCC CFR Title 47 Part 2, Part 90
Test Report Form No. : LCSEMC-1.0
TRF Originator : Shenzhen LCS Compliance Testing Laboratory Ltd.
Master TRF : Dated 2011-03

Shenzhen LCS Compliance Testing Laboratory Ltd. All rights reserved.

This publication may be reproduced in whole or in part for non-commercial purposes as long as the Shenzhen LCS Compliance Testing Laboratory Ltd. is acknowledged as copyright owner and source of the material. Shenzhen LCS Compliance Testing Laboratory Ltd. takes no responsibility for and will not assume liability for damages resulting from the reader's interpretation of the reproduced material due to its placement and context.

Test Item Description : UDR-S400
Trade Mark : UNIMO
Test Model : UDR-S400
Ratings : For Adapter: Input:100-240V~ 50/60Hz 0.5A
Output: 12.0V 1.0A 12.0W
For EUT: Input: DC 12V, 1000A
Output: DC 8.4V, 850mA
Battery: DC 7.2V, 2600mAh

Result : Positive

Compiled by:

Li Huan signature

Li Huan/ Administrator

Supervised by:

Cary Luo signature

Cary Luo/ Technique principal

Approved by:

Gavin Liang signature

Gavin Liang/ Manager





RADIO -- TEST REPORT

Test Report No. : LCSA04114110EA	<u>May 24, 2024</u> Date of issue
---	--------------------------------------

Test Model.....	: UDR-S400
EUT.....	: UDR-S400
Applicant.....	: Unimo Technology Co., Ltd.
Address.....	: 6F, Hanshin IT 2nd Tower, 47 Digital-Ro 9-Gil,Gu office 603 Seoul, Rep of Korea 08511 South Korea
Telephone.....	: /
Fax.....	: /
Manufacturer.....	: UNIMO TECHNOLOGY CO.,LTD.
Address.....	: 6F, 47, Digital-ro 9-gil, Geumcheon-Gu, Seoul, Republic of Korea (08511)
Telephone.....	: /
Fax.....	: /
Factory.....	: UNIMO TECHNOLOGY CO.,LTD.
Address.....	: 6F, 47, Digital-ro 9-gil, Geumcheon-Gu, Seoul, Republic of Korea (08511)
Telephone.....	: /
Fax.....	: /

Test Result	Positive
--------------------	-----------------

The test report merely corresponds to the test sample.
It is not permitted to copy extracts of these test result without the written permission of the test laboratory.





Revision History

Report Version	Issue Date	Revision Content	Revised By
000	May 24, 2024	Initial Issue	--





TABLE OF CONTENTS

Test Report Description	Page
1. GENERAL INFORMATION	7
1.1. DESCRIPTION OF DEVICE (EUT)	7
1.2. HOST SYSTEM CONFIGURATION LIST AND DETAILS	8
1.3. EXTERNAL I/O CABLE	8
1.4. DESCRIPTION OF TEST FACILITY	8
1.5. STATEMENT OF THE MEASUREMENT UNCERTAINTY	8
1.6. MEASUREMENT UNCERTAINTY	9
1.7. DESCRIPTION OF TEST MODES	9
2. SYSTEM TEST CONFIGURATION	10
2.1. TEST STANDARDS	10
2.2. EUT CONFIGURATION	10
2.3. EUT EXERCISE	10
2.4. TEST SAMPLE	10
3. SYSTEM TEST CONFIGURATION	11
3.1. JUSTIFICATION	11
3.2. EUT EXERCISE SOFTWARE	11
3.3. SPECIAL ACCESSORIES	11
3.4. BLOCK DIAGRAM/SCHEMATICS	11
3.5. EQUIPMENT MODIFICATIONS	11
3.6. TEST SETUP	11
4. SUMMARY OF TEST RESULT	12
5. TEST CONDITIONS AND RESULTS	13
5.1. MAXIMUM TRANSMITTER POWER	13
5.1.1 Test Applicable	13
5.1.2 Test Procedure	13
5.1.3 Test Configuration	13
5.1.4 Test Results	13
5.2. OCCUPIED BANDWIDTH AND EMISSION MASK TEST	19
5.2.1 Test Applicable	19
5.2.2 Test Configuration	19
5.2.3 Test Procedure	19
5.2.4 Test Results	20
5.3. TRANSMITTER RADIATED SPURIOUS EMISSION	30
5.3.1 Test Applicable	30
5.3.2 Test Configuration	30
5.3.3 Test Arrangement	31
5.3.4 Test Procedure	31
5.3.5 Limit	32
5.3.5 Test Results	32
5.4. SPURIOUS EMISSION ON ANTENNA PORT	35
5.4.1 Test Applicable	35
5.4.2 Test Procedure	35
5.4.3 Test Configuration	35
5.4.4 Limit	35
5.4.5 Test Results	36
5.5. FREQUENCY STABILITY TEST	39
5.5.1 Test Applicable	39
5.5.2 Test Procedure	39
5.5.3 Test Configuration	39
5.5.4 Test Limits	39
5.5.5 Test Results	40
5.6. TRANSIENT FREQUENCY BEHAVIOR	41
5.6.1 Test Applicable	41





5.6.2 Test Configuration 41

5.6.3 Test Procedure 41

5.6.4 Test Results 42

5.7. FCC §2.1047 - MODULATION CHARACTERISTIC 43

5.7.1 Test Applicable 43

Applicable Standard 43

Test Procedure 43

Test Mode: Transmitting 43

12.5kHz: 44

..... 44

12.5kHz 45

6. LIST OF MEASURING EQUIPMENT 46

7. TEST SETUP PHOTOGRAPHS OF EUT 47

8. EXTERIOR PHOTOGRAPHS OF THE EUT 48

9. INTERIOR PHOTOGRAPHS OF THE EUT 48





1. GENERAL INFORMATION

1.1. Description of Device (EUT)

EUT	: UDR-S400
Test Model	: UDR-S400
Power Supply	: For Adapter: Input:100-240V~ 50/60Hz 0.5A Output: 12.0V $\overline{\text{---}}$ 1.0A 12.0W For EUT: Input: DC 12V, 1000A Output: DC 8.4V, 850mA Battery: DC 7.2V, 2600mAh
Hardware Version	: V1.0
Software Version	: V1.0
PMR	:
Operating Frequency	: 400 ~ 470MHz
Channel Separation	: 12.5KHz
Modulation Type	: 4FSK/FM
Emission Designator	: 8K28FXD for 4FSK/FM Modulation at 12.5KHz Channel Separation
Antenna Type	: External Antenna
Antenna Gain	: 0dBi (max.)
Rated Output Power	: High Power 5W ; Lower Power 2W





1.2. Host System Configuration List and Details

Manufacturer	Description	Model	Serial Number	Certificate
--	AC DC ADAPTER	OUSM-1200100	--	FCC

1.3. External I/O Cable

I/O Port Description	Quantity	Cable
Power Port	1	N/A
Antenna Port	1	N/A

1.4. Description of Test Facility

NVLAP Accreditation Code is 600167-0.

FCC Designation Number is CN5024.

CAB identifier is CN0071.

CNAS Registration Number is L4595.

Test Firm Registration Number: 254912.

The sites are constructed in conformance with the requirements of ANSI C63.4 (2014) and CISPR Publication 22.

1.5. Statement of the Measurement Uncertainty

The data and results referenced in this document are true and accurate. The reader is cautioned that there may be errors within the calibration limits of the equipment and facilities. The measurement uncertainty was calculated for all measurements listed in this test report acc. to ETSI TR 100 028 “Electromagnetic compatibility and Radio spectrum Matters (ERM); Uncertainties in the measurement of mobile radio equipment characteristics” and is documented in the Shenzhen LCS Compliance Testing Laboratory Ltd. quality system acc. to DIN EN ISO/IEC 17025. Furthermore, component and process variability of devices similar to that tested may result in additional deviation. The manufacturer has the sole responsibility of continued compliance of the device.





1.6. Measurement Uncertainty

Test Item	Uncertainty	Note
Frequency error	30 Hz	(1)
Transmitter power conducted	0.62 dB	(1)
Transmitter power Radiated	2.67 dB	(1)
Conducted spurious emission 9KHz-12.75 GHz	1.22 dB	(1)
Conducted Emission 9KHz-30MHz	1.63 dB	(1)
Radiated spurious emission 30~1000MHz	3.10 dB	(1)
Radiated spurious emission 1~18GHz	3.80 dB	(1)
Radiated spurious emission 18-40GHz	3.90 dB	(1)
Occupied Bandwidth	35Hz	(1)
Emission Mask	1.25dB	(1)
Transmitter Frequency Behavior	6.8%	(1)

(1) . This uncertainty represents an expanded uncertainty expressed at approximately the 95% confidence level using a coverage factor of k=2.

1.7. Description of Test Modes

The EUT has been tested under typical operating condition. As, test modes selected as below by the technical parameters of the EUT:

Operation Mode	Description of operation mode	Additional information
TM1	4FSK+BW12.5KHz+TX	The EUT is set with 4FSK modulation and 12.5KHz bandwidth at maximum rated power for transmitter, powered by DC 7.20V power Rechargeable Li-ion Battery
TM2	4FSK+BW12.5KHz+TX	The EUT is set with 4FSK modulation and 12.5KHz bandwidth at minimum rated power for transmitter, powered by DC 7.20V power Rechargeable Li-ion Battery
TM3	FM+BW12.5KHz+TX	The EUT is set with FM modulation and 12.5KHz bandwidth at maximum rated power for transmitter, powered by DC 7.20V power Rechargeable Li-ion Battery
TM4	FM+BW12.5KHz+TX	The EUT is set with FM modulation and 12.5KHz bandwidth at minimum rated power for transmitter, powered by DC 7.20V power Rechargeable Li-ion Battery





2. SYSTEM TEST CONFIGURATION

2.1. TEST STANDARDS

The tests were performed according to following standards:

[FCC Rules Part 90](#): PRIVATE LAND MOBILE RADIO SERVICES.

[ANSI/TIA-603-E-2016](#): Land Mobile FM or PM Communications Equipment Measurement and Performance Standards.

[47 CFR FCC Part 15 Subpart B](#): Unintentional Radiators

[FCC Part 2](#): FREQUENCY ALLOCATIONS AND RADIO TREATY MATTERS; GENERAL RULES AND REGULATIONS

[ANSI C63.26:2015](#): American National Standard for Compliance Testing of Transmitters Used in Licensed Radio Services.

[ANSI C63.4:2014](#): Methods of Measurement of Radio-Noise Emissions from Low-Voltage Electrical and Electronic Equipment in the Range of 9 kHz to 40 GHz

2.2. EUT Configuration

The EUT configuration for testing is installed on RF field strength measurement to meet the Commissions requirement and operating in a manner that intends to maximize its emission characteristics in a continuous normal application.

2.3. EUT Exercise

The EUT has been tested under typical operating condition and The Transmitter was operated in the normal operating mode. The TX frequency was fixed which was for the purpose of the measurements.

2.4. Test Sample

The application provides 1 samples to meet requirement;

Sample Number	Description
Sample 1	continuous transmit





3. SYSTEM TEST CONFIGURATION

3.1. Justification

The system was configured for testing in a continuous transmits condition.

3.2. EUT Exercise Software

N/ A

3.3. Special Accessories

N/ A

3.4. Block Diagram/Schematics

Please refer to the related document

3.5. Equipment Modifications

Shenzhen LCS Compliance Testing Laboratory Ltd. has not done any modification on the EUT.

3.6. Test Setup

Please refer to the test setup photo.





4. SUMMARY OF TEST RESULT

Transmitter Requirements				
FCC General Rules Part (47CFR)	Description of Test	Test Sample	Result	Remark
2.1046 90.205	Maximum Transmitter Power	Sample 1	Compliant	Note 1
2.1047 (a) 90.207	Modulation Characteristics - Audio Frequency Response	Sample 1	N/A*	Note 2
2.1047 (b) 90.207	Modulation Characteristics - Modulation Limiting	Sample 1	N/A*	Note 2
2.1049 90.210	Occupied Bandwidth Tests; Emission Mask	Sample 1	Compliant	Note 1
2.1055 90.213	Frequency Stability	Sample 1	Compliant	Note 1
90.214	Transient Frequency Behavior	Sample 1	Compliant	Note 1
2.1053 90.210	Transmitter Radiated Spurious Emission	Sample 1	Compliant	Note 1
2.1051 90.210	Spurious Emission On Antenna Port	Sample 1	Compliant	Note 1

Remark:

- 1. Note 1 – Test results inside test report;
- 2. Note 2 – N/A* - Not Applicable for this device because it is digital device.



5. TEST CONDITIONS AND RESULTS

5.1. Maximum Transmitter Power

5.1.1 Test Applicable

Per FCC Part 2.1046 and Part 90.205: Maximum ERP is dependent upon the station's antenna HAAT and required service area

5.1.2 Test Procedure

Measurements shall be made to establish the radio frequency power delivered by the transmitter the standard output termination. The power output shall be monitored and recorded and no adjustment shall be made to the transmitter after the test has begun, except as noted below:

If the power output is adjustable, measurements shall be made for the highest and lowest power levels.

The EUT connect to the Receiver through 20 dB attenuator.

Measurement with Spectrum Analyzer conducted external power supply with 7.2V stabilized supply voltage.

5.1.3 Test Configuration

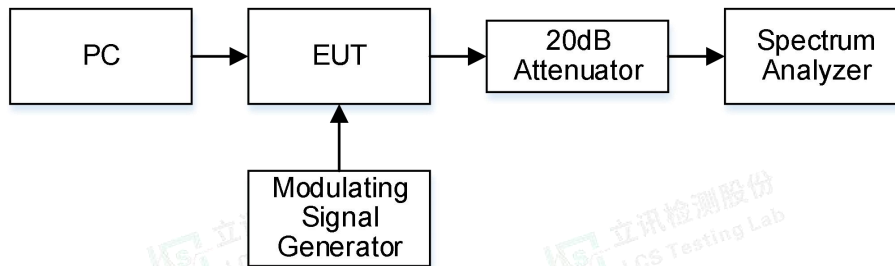

5.1.4 Test Results

Temperature	23.8°C	Humidity	54.6%
Test Engineer	Paddi Chen	Test Voltage	Normal Voltage

Modulation Type	Channel Separation	Operation Mode	Test Channel	Test Frequency (MHz)	Test Results (dBm)	Limit (dBm)
Digital 4FSK	12.5KHz	TM1	L	406.1125	36.996	37 ± 1
			M 1	430.1125	37.313	37 ± 1
			M 2	453.2125	37.021	37 ± 1
			M 3	459.625	37.321	37 ± 1
			M 4	465.625	37.230	37 ± 1
	H	469.9875	36.963	37 ± 1		
	12.5KHz	TM2	L	406.1125	33.692	33 ± 1
			M 1	430.1125	33.343	33 ± 1
			M 2	453.2125	33.738	33 ± 1
			M 3	459.625	33.527	33 ± 1
M 4			465.625	33.402	33 ± 1	
H	469.9875	33.259	33 ± 1			
FM	12.5KHz	TM3	L	406.1125	36.802	37 ± 1
			M 1	430.1125	37.077	37 ± 1
			M 2	453.2125	37.060	37 ± 1
			M 3	459.625	37.076	37 ± 1
			M 4	465.625	37.037	37 ± 1
	H	469.9875	36.907	37 ± 1		
	12.5KHz	TM4	L	406.1125	33.294	33 ± 1





		M 1	430.1125	33.135	33±1
		M 2	453.2125	33.534	33±1
		M 3	459.625	33.490	33±1
		M 4	465.625	33.459	33±1
		H	469.9875	33.132	33±1
Limit	The limit is dependent upon the station's antenna HAAT and required service area.				
Test Results		PASS			

Note: The high rated power level is 5W(37dBm), and low rated power level is 2W(33dBm).
 The output power shall not exceed by more than ±1dBm the manufacturer's rated output power for the particular transmitter specifically listed on the authorization





Remark:

1. Please refer to following plot.

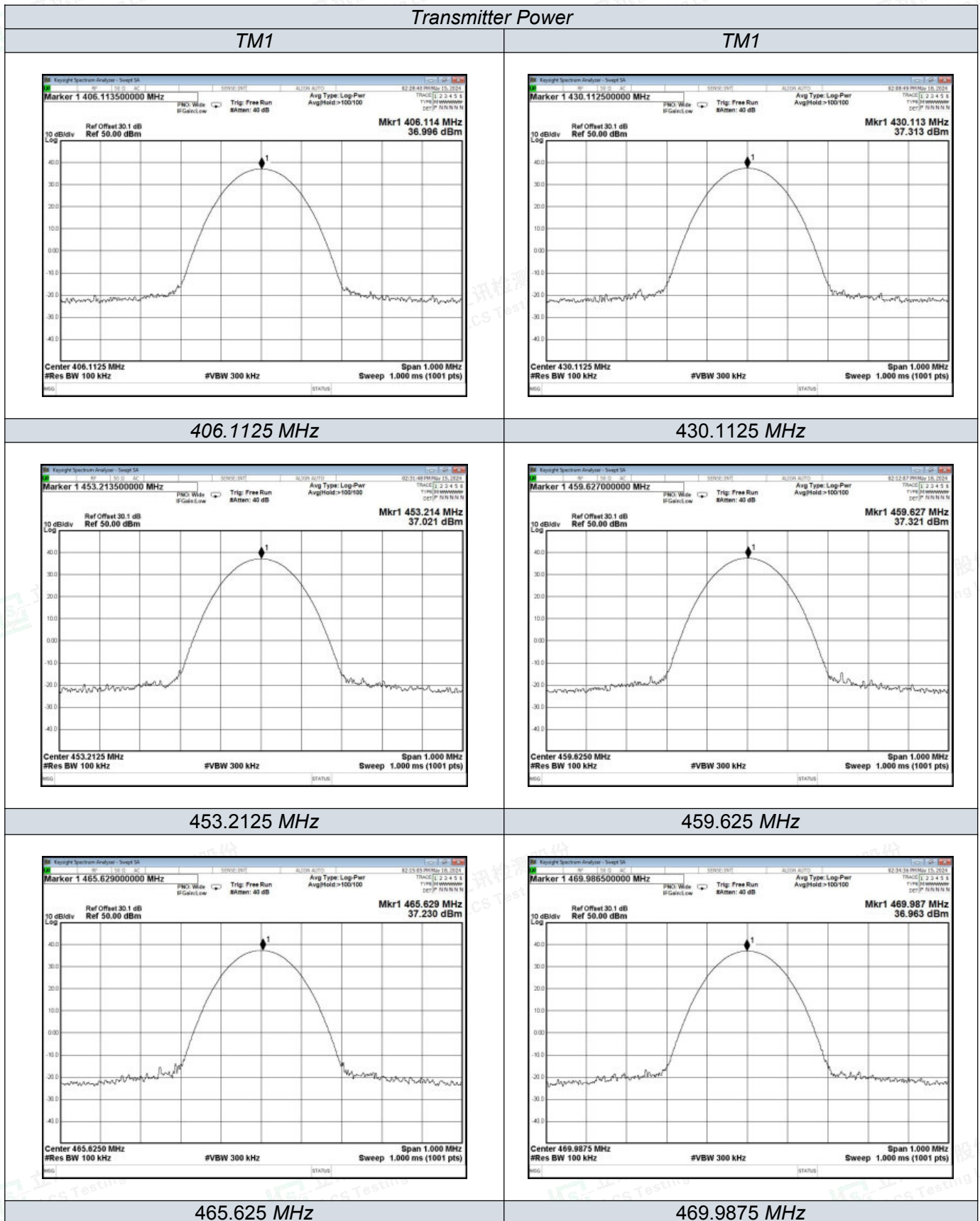



Transmitter Power

TM2

TM2

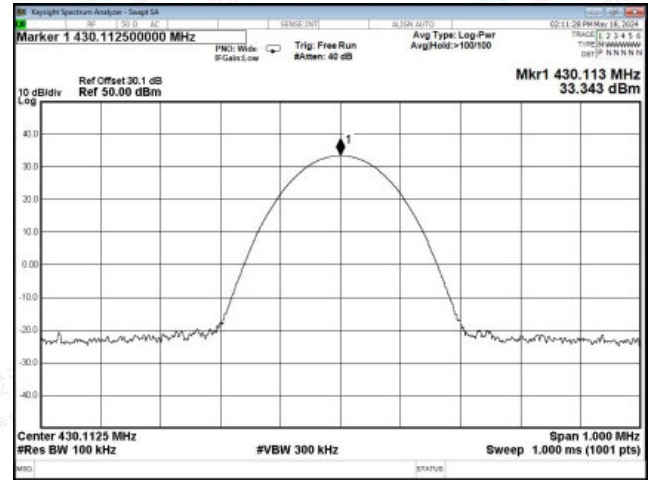
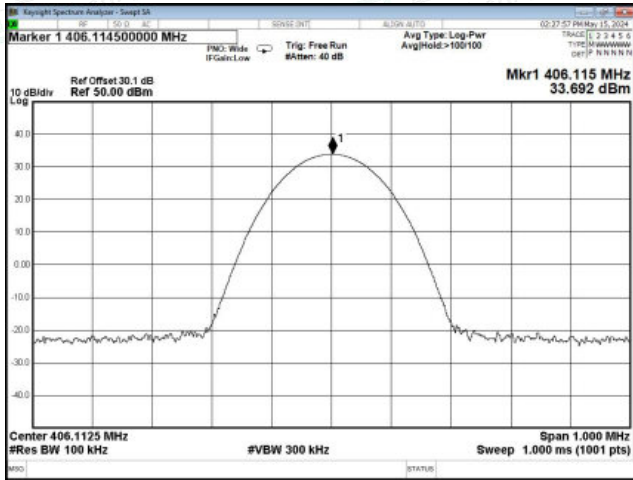

406.1125 MHz

430.1125 MHz

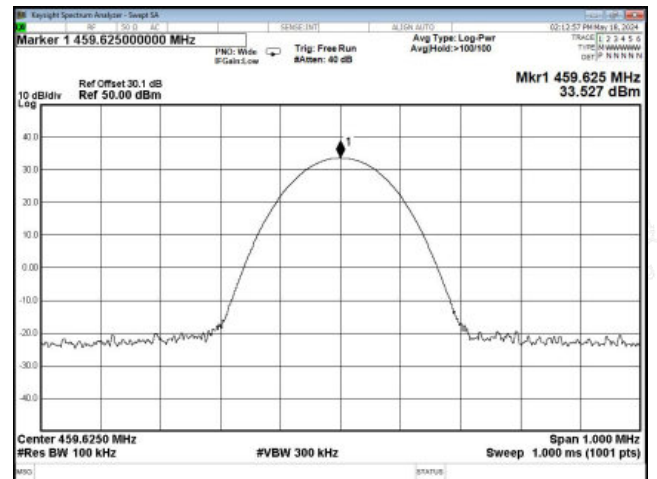
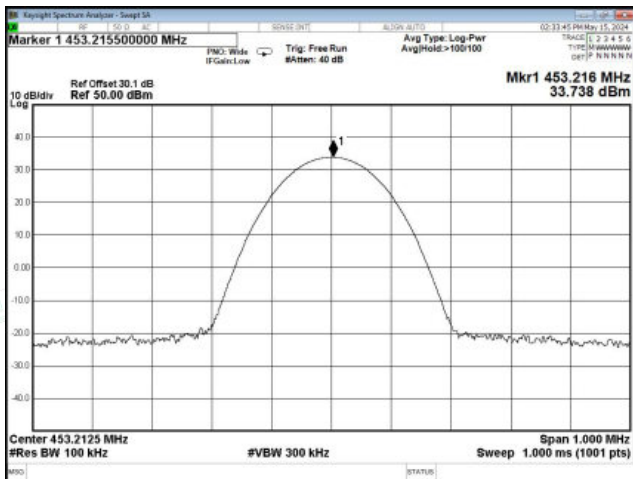

453.2125 MHz

459.625 MHz

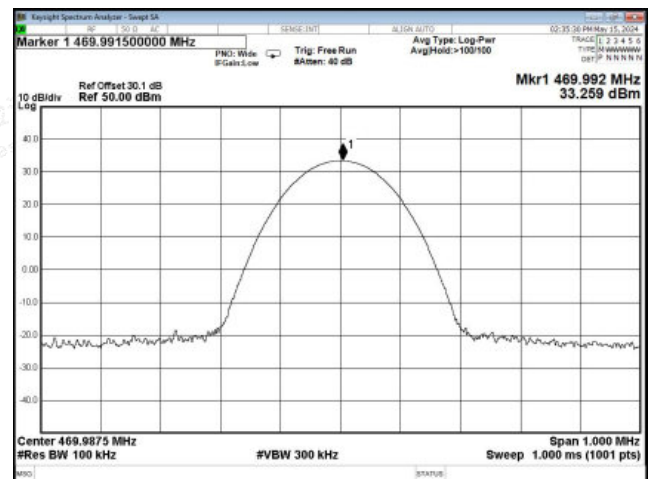
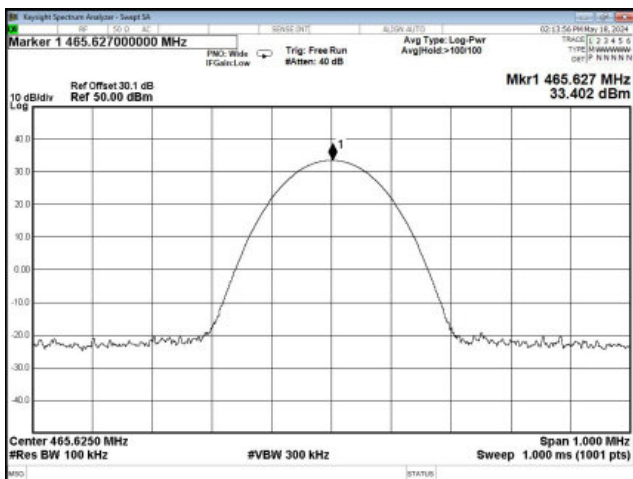

465.625 MHz

469.9875 MHz





Transmitter Power

TM3

TM3

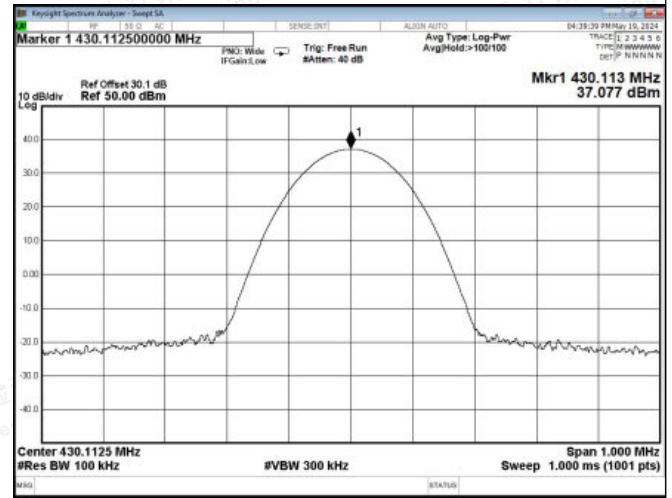
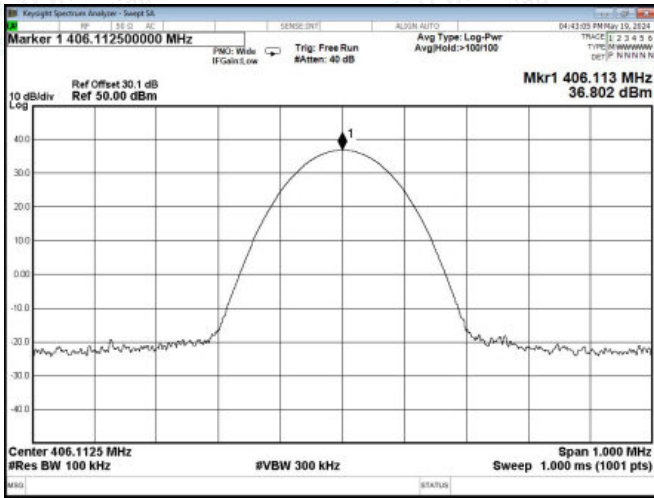

406.1125 MHz

430.1125 MHz

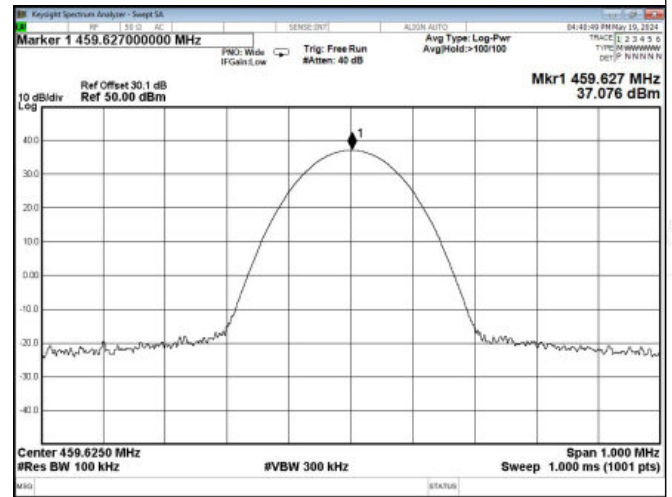
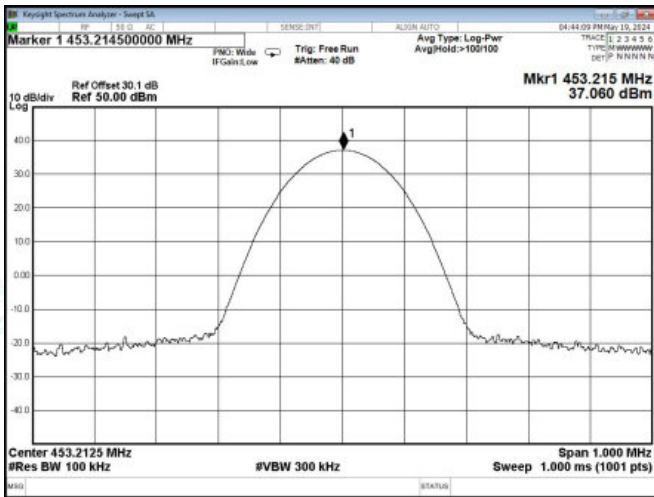

453.2125 MHz

459.625 MHz

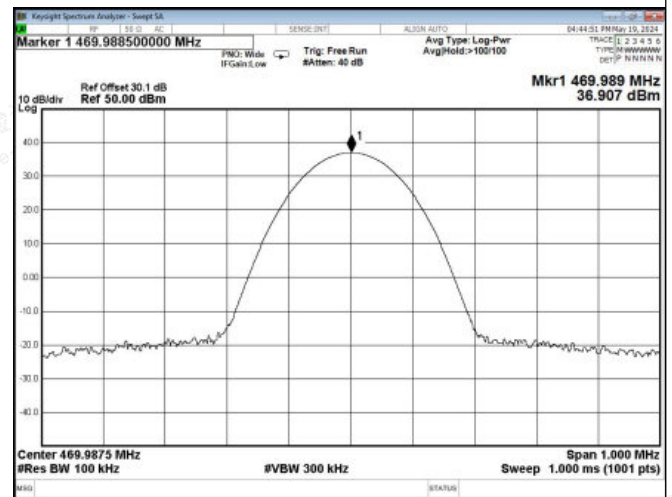
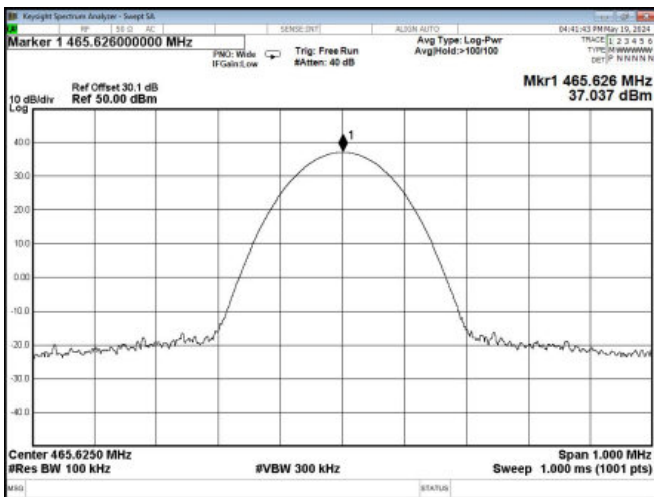

465.625 MHz

469.9875 MHz





Transmitter Power

TM4

TM4

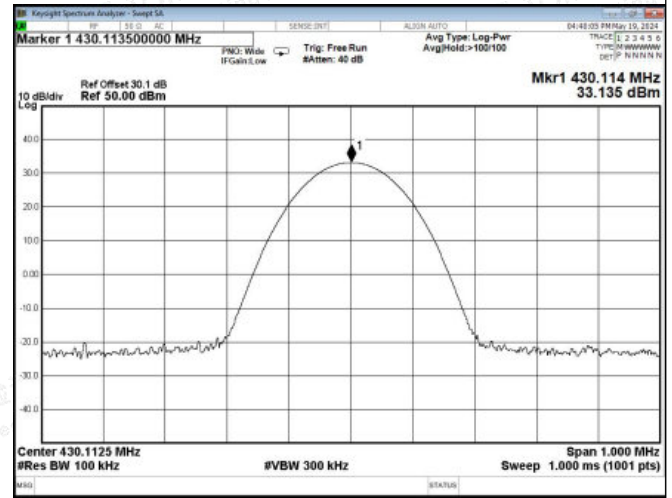
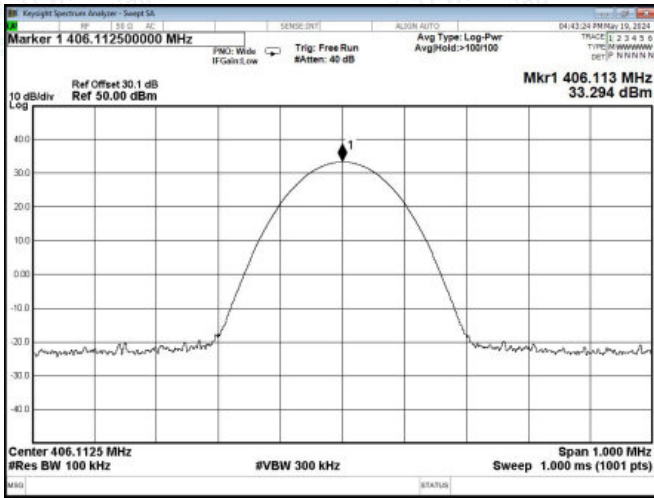

406.1125 MHz

430.1125 MHz

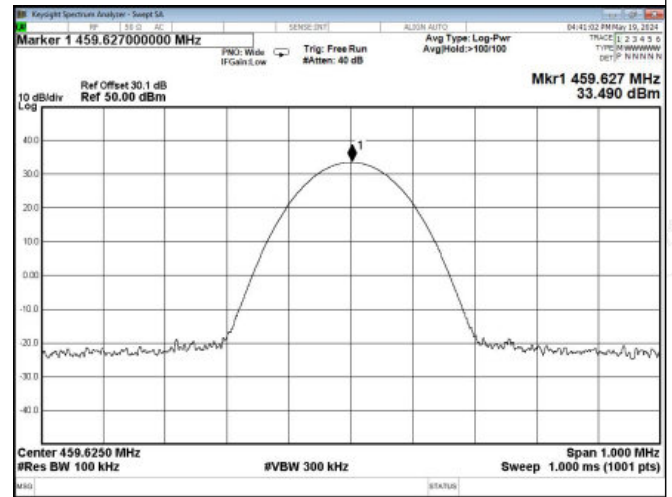
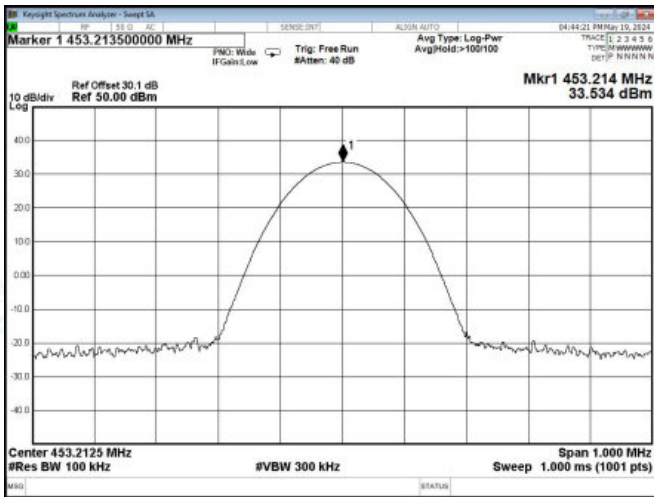

453.2125 MHz

459.625 MHz

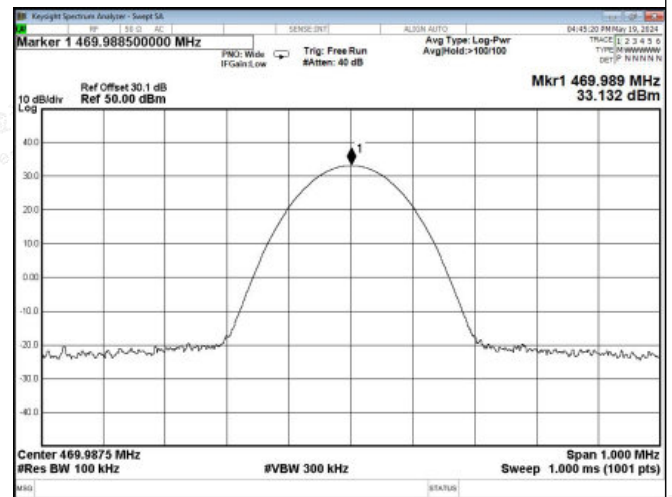
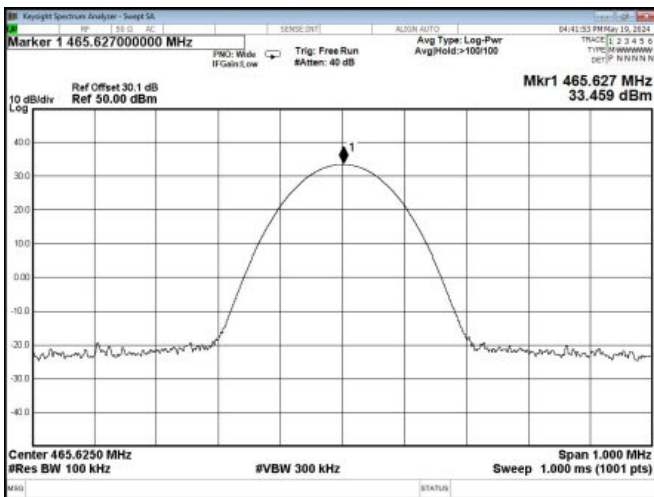

465.625 MHz

469.9875 MHz



5.2. Occupied Bandwidth and Emission Mask Test

5.2.1 Test Applicable

- (a). Occupied Bandwidth: The EUT was connected to the audio signal generator and the spectrum analyser via the main RF connector, and through an appropriate attenuator. The EUT was controlled to transmit its maximum power. Then the bandwidth of 99% power can be measured by the spectrum analyser.
- (b). Emission Mask B: For transmitters that are equipped with an audio low-pass filter pursuant to §90.211(a), the power of any emission must be below the unmodulated carrier power (P) as follows:
 - (1) On any frequency removed from the assigned frequency by more than 50 percent, but not more than 100 percent of the authorized bandwidth: At least 25dB.
 - (2) On any frequency removed from the assigned frequency by more than 100 percent, but not more than 250 percent of the authorized bandwidth: At least 35dB.
 - (3) On any frequency removed from the assigned frequency by more than 250 percent of the authorized bandwidth: At least $43 + 10 \log (P)$ dB.
- (c). Emission Mask D, 12.5 kHz channel bandwidth equipment: For transmitters designed to operate with a 12.5 kHz channel bandwidth, any emission must be attenuated below the power (P) of the highest emission contained within the authorized bandwidth as follows:
 - (1) On any frequency from the centre of the authorized bandwidth f_0 to 5.625 kHz removed from f_0 : Zero dB.
 - (2) On any frequency removed from the centre of the authorized bandwidth by a displacement frequency (f_d in kHz) of more than 5.625 kHz but no more than 12.5 kHz: At least $7.27(f_d - 2.88 \text{ kHz})$ dB.
 - (3) On any frequency removed from the centre of the authorized bandwidth by a displacement frequency (f_d in kHz) of more than 12.5 kHz: At least $50 + 10 \log (P)$ dB or 70 dB, whichever is the lesser attenuation.

5.2.2 Test Configuration

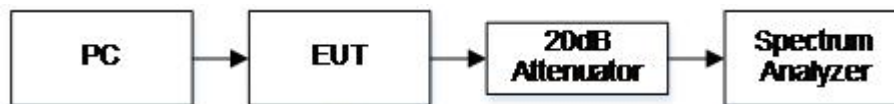

5.2.3 Test Procedure

- 1 Set EUT as normal operation.
- 2 Set SPA Centre Frequency = fundamental frequency, RBW=300Hz, VBW= 1 KHz, span =50 KHz .
- 3 Set SPA Max hold. Mark peak, Set 99% Occupied Bandwidth and 26dB Occupied Bandwidth.





5.2.4 Test Results

Temperature	23.8°C	Humidity	54.6%
Test Engineer	Paddi Chen	Test Voltage	Normal Voltage

Occupied Bandwidth

Modulation Type	Channel Separation	Operation Mode	Test Channel	Test Frequency (MHz)	Occupied Bandwidth (KHz)	
					99%	26dB
4FSK	12.5 KHz	TM1	L	406.1125	7.742	9.811
			M 1	430.1125	7.622	9.660
			M 2	453.2125	7.475	9.446
			M 3	459.625	7.712	9.770
			M 4	465.625	7.818	9.766
			H	469.9875	7.680	9.742
4FSK	12.5 KHz	TM2	L	406.1125	7.733	10.51
			M 1	430.1125	7.596	9.588
			M 2	453.2125	7.735	9.529
			M 3	459.625	7.743	9.582
			M 4	465.625	7.827	10.20
			H	469.9875	7.737	9.760
FM	12.5 KHz	TM3	L	406.1125	6.643	7.217
			M 1	430.1125	6.650	7.221
			M 2	453.2125	6.647	7.217
			M 3	459.625	6.652	7.215
			M 4	465.625	6.648	7.221
			H	469.9875	6.648	7.215
FM	12.5 KHz	TM4	L	406.1125	6.619	7.217
			M 1	430.1125	6.650	7.221
			M 2	453.2125	6.643	7.214
			M 3	459.625	6.650	7.213
			M 4	465.625	6.655	7.219
			H	469.9875	6.637	7.215
Limit			11.25KHz for 12.5KHz Channel Separation			
Test Results			PASS			

Remark:

2. Please refer to following plots.





99% and 26dB Bandwidth

TM1

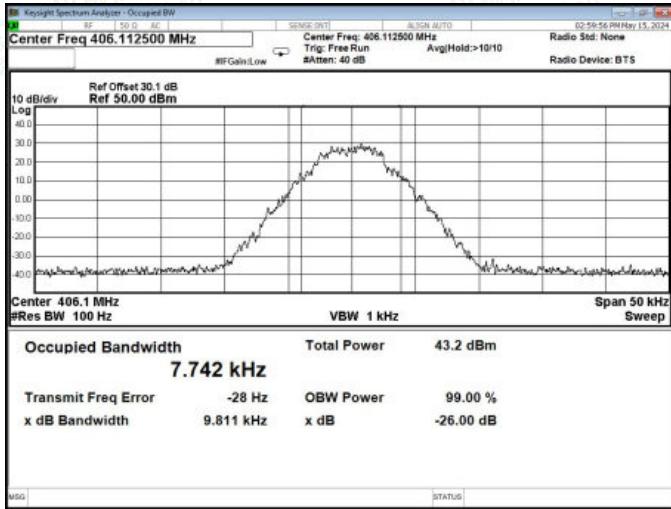

TM1

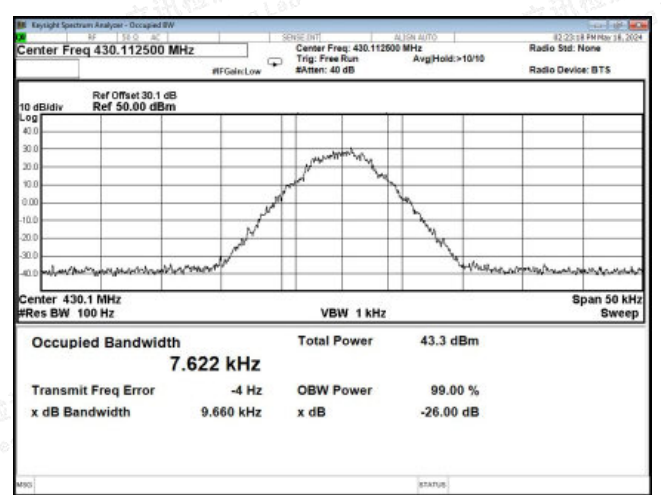

406.1125 MHz

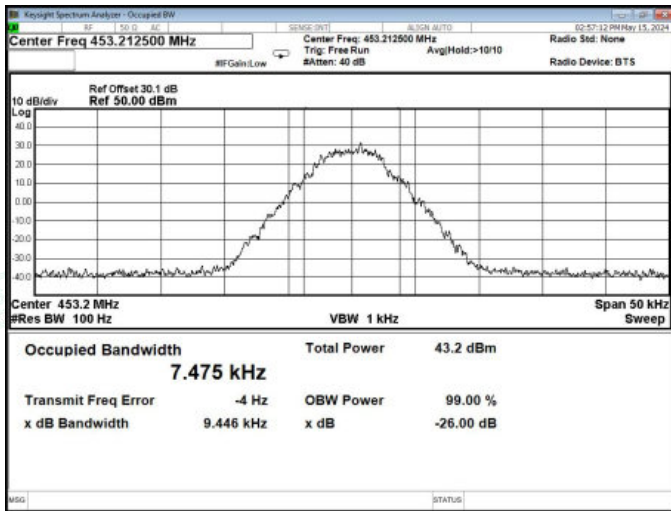

430.1125 MHz

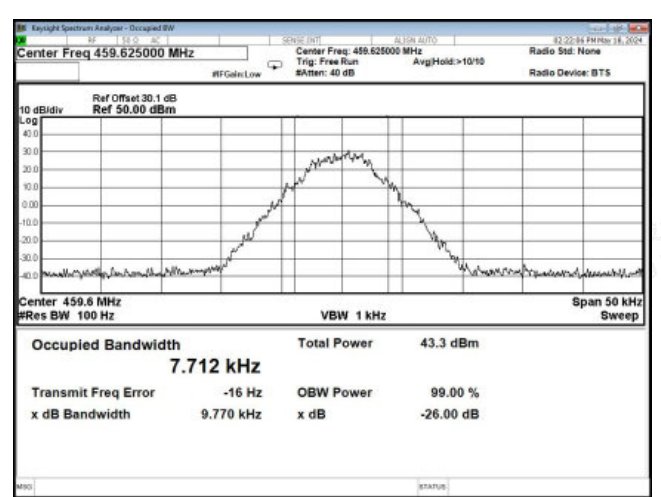

453.2125 MHz

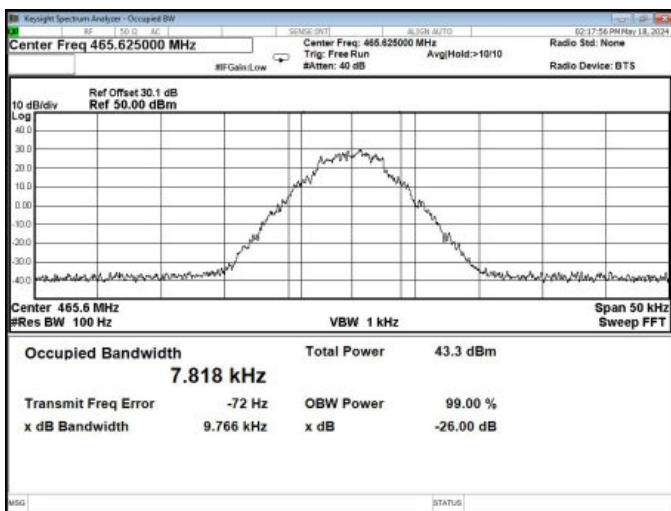

459.625 MHz

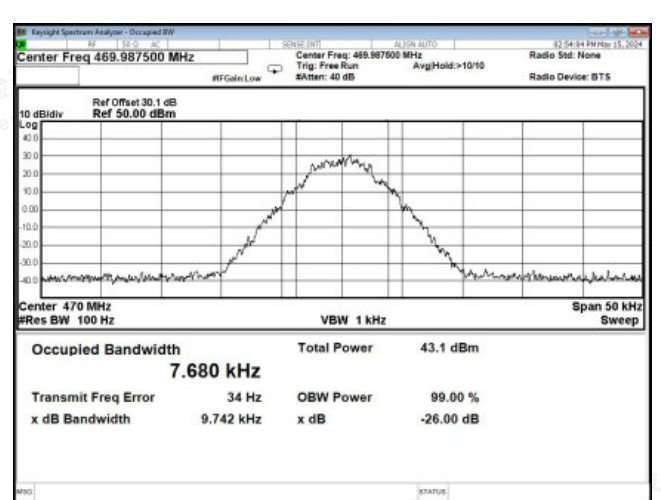

465.625 MHz

469.9875 MHz





99% and 26dB Bandwidth

TM2

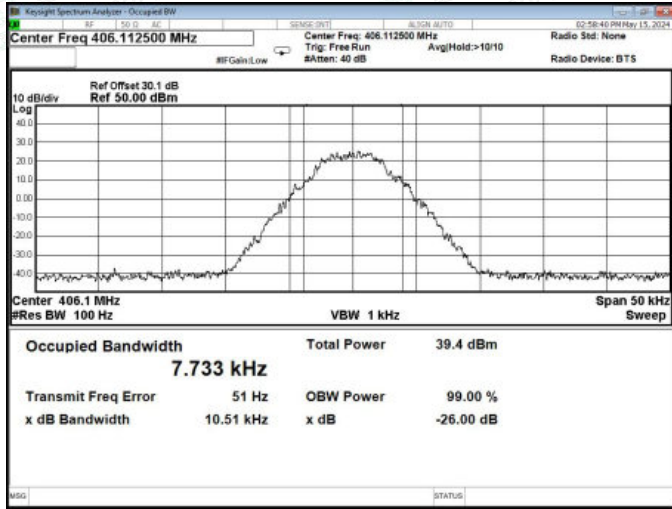

TM2

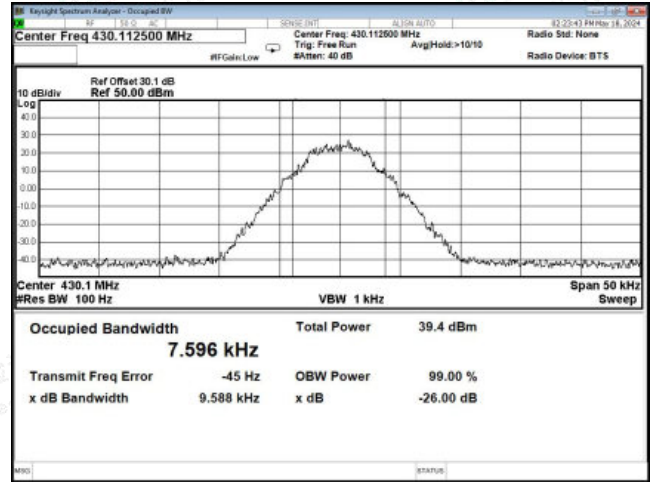

406.1125 MHz

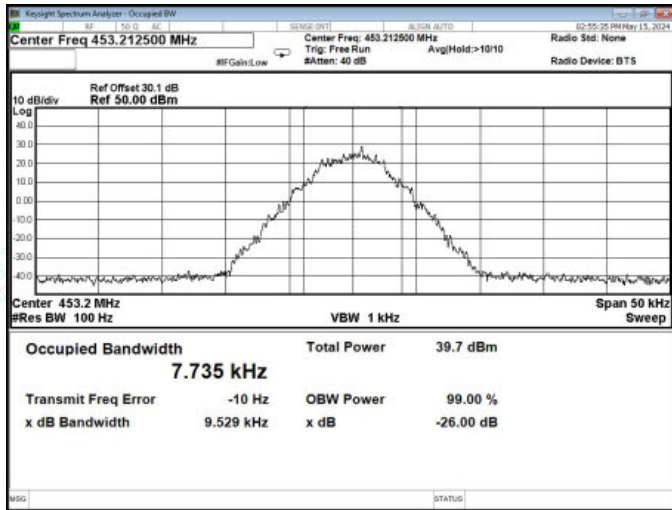

430.1125 MHz

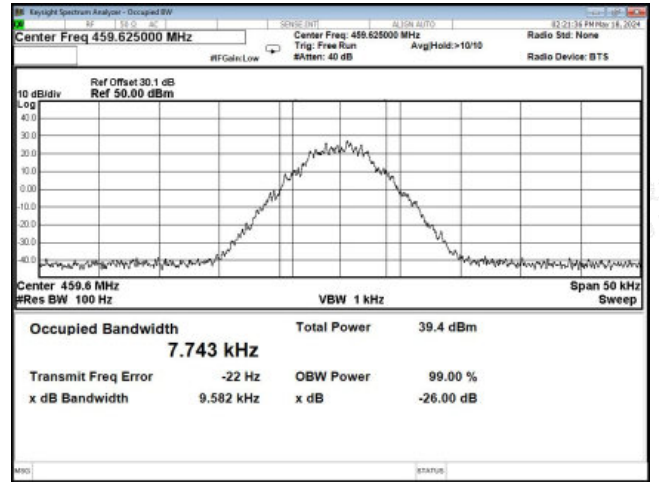

453.2125 MHz

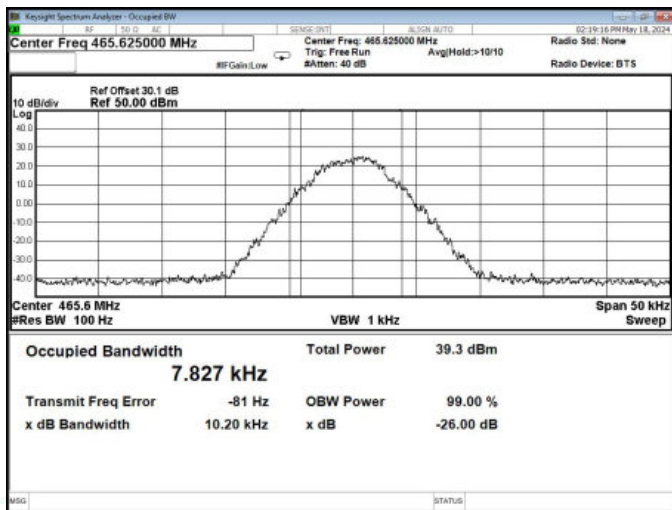

459.625 MHz

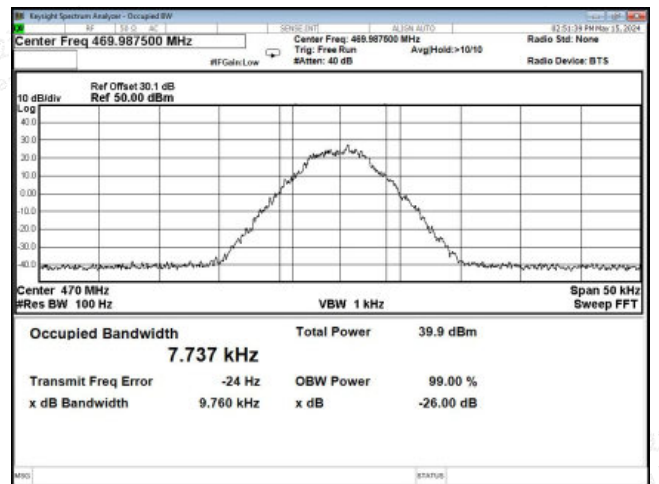

465.625 MHz



469.9875 MHz





99% and 26dB Bandwidth

TM3

TM3

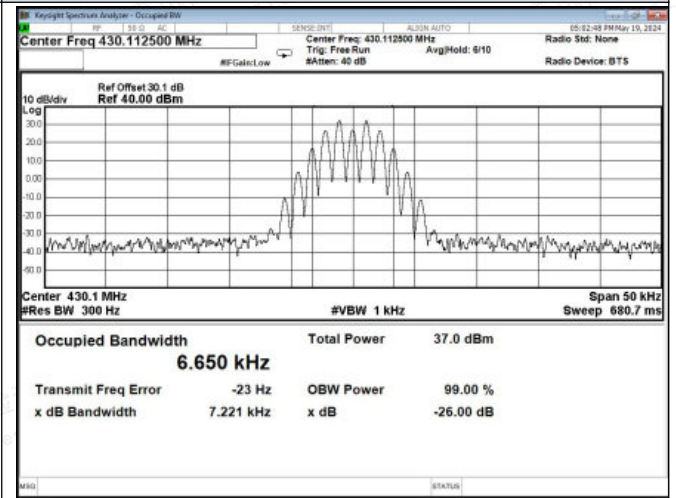
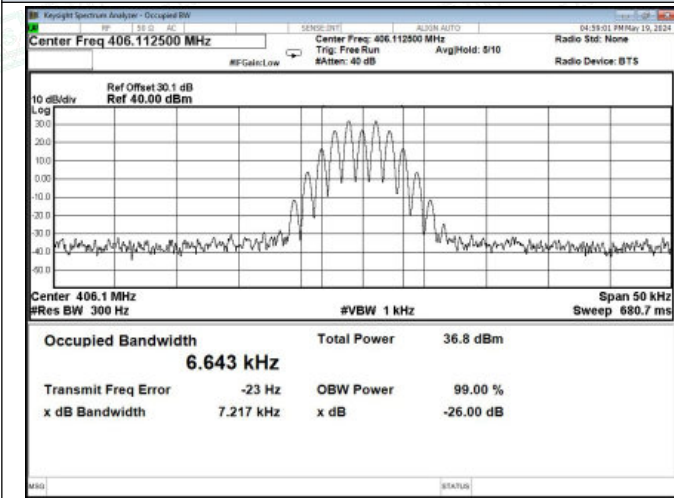

406.1125 MHz

430.1125 MHz

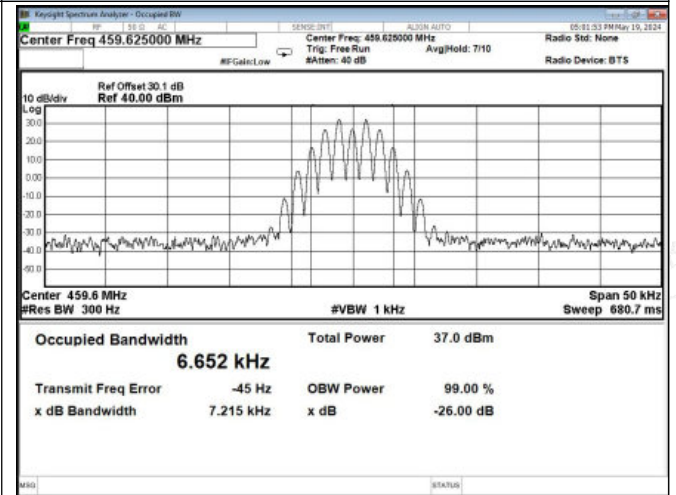
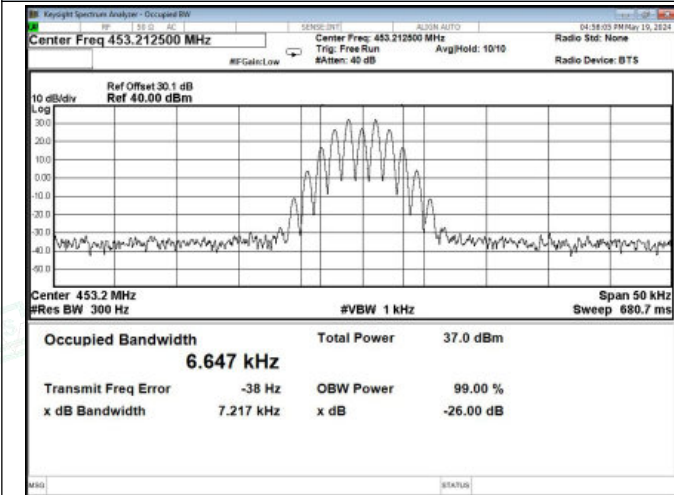

453.2125 MHz

459.625 MHz

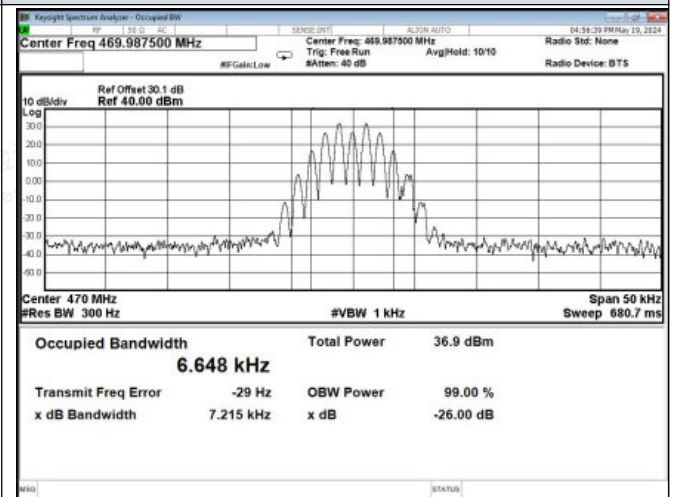
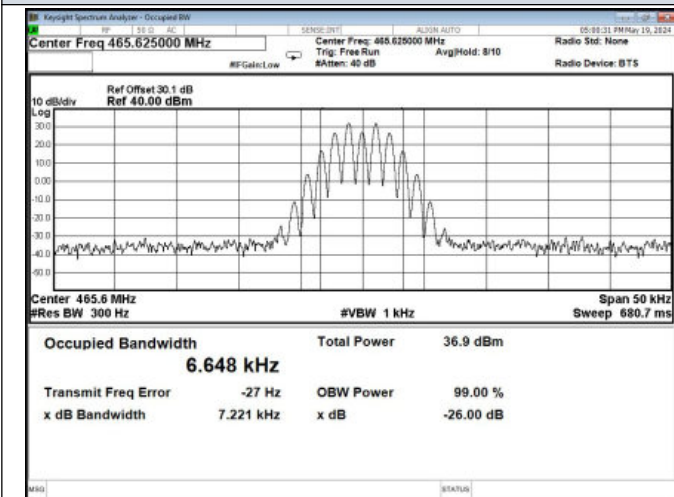

465.625 MHz

469.9875 MHz





99% and 26dB Bandwidth

TM4

TM4

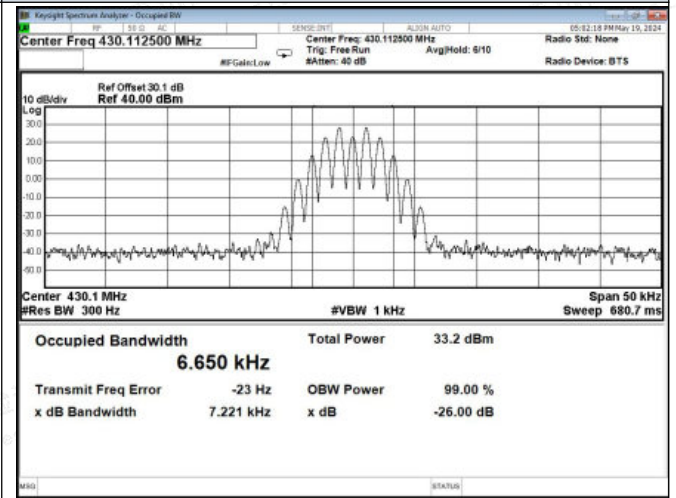
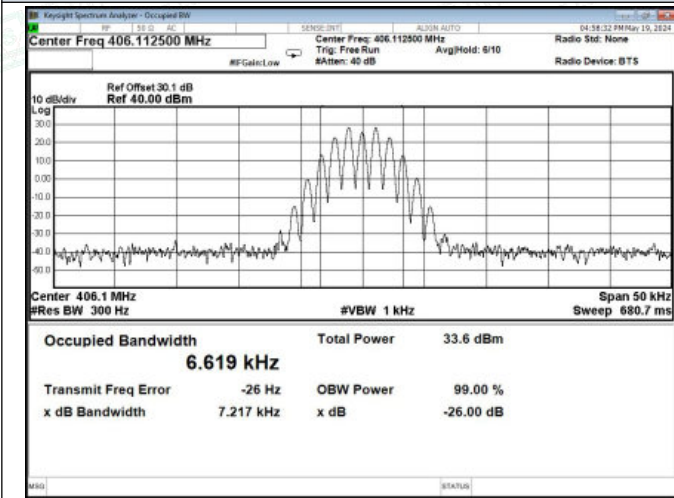

406.1125 MHz

430.1125 MHz

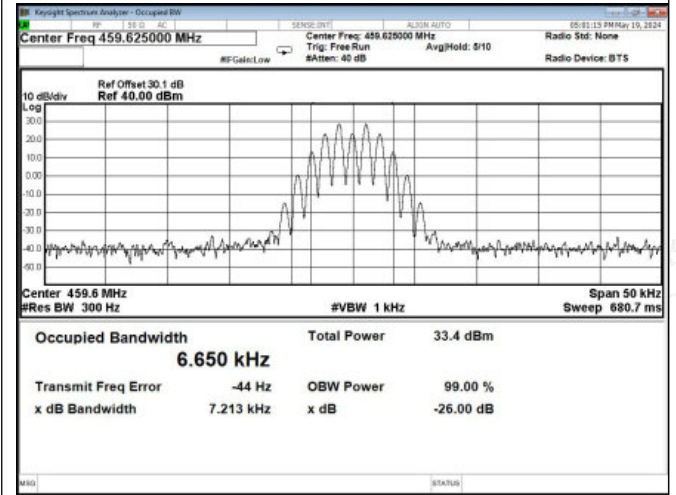
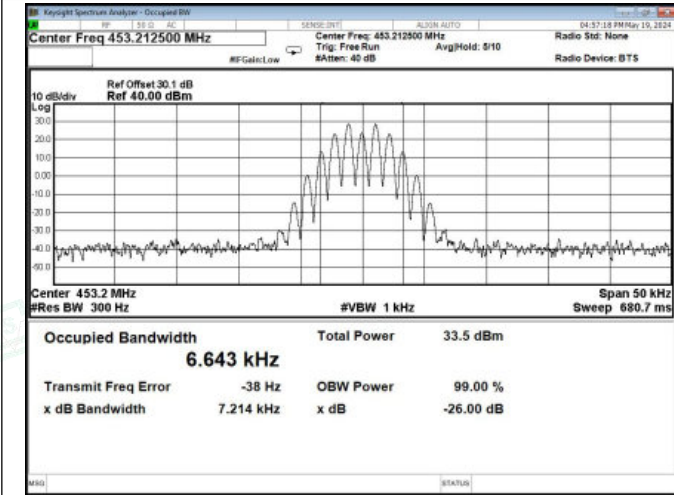

453.2125 MHz

459.625 MHz

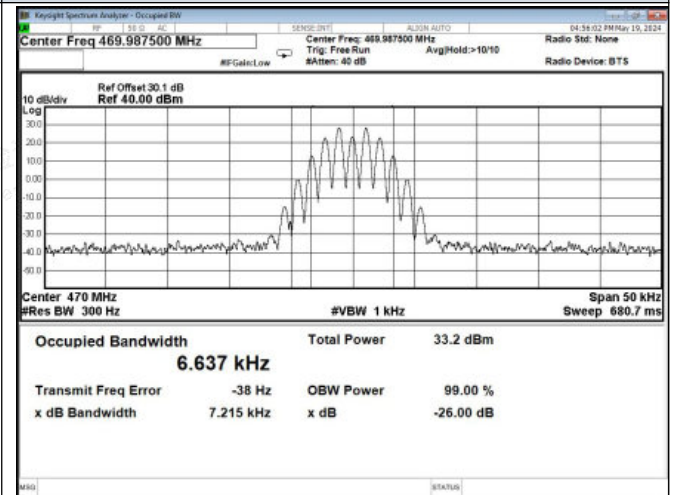
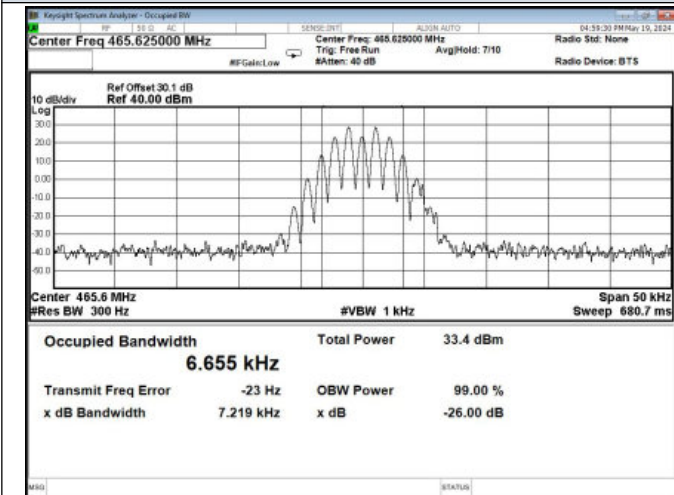

465.625 MHz

469.9875 MHz





Temperature	23.8°C	Humidity	54.6%
Test Engineer	Paddi Chen	Test Voltage	Normal Voltage

Emission Mask

Modulation Type	Channel Separation	Operation Mode	Test Channel	Test Frequency (MHz)	Applicable Mask	RBW (Hz)
4FSK	12.5 KHz	TM1	L	406.1125	D	100
			M 1	430.1125	D	100
			M 2	453.2125	D	100
			M 3	459.625	D	100
			M 4	465.625	D	100
			H	469.9875	D	100
4FSK	12.5 KHz	TM2	L	406.1125	D	100
			M 1	430.1125	D	100
			M 2	453.2125	D	100
			M 3	459.625	D	100
			M 4	465.625	D	100
			H	469.9875	D	100
FM	12.5 KHz	TM3	L	406.1125	D	300
			M 1	430.1125	D	300
			M 2	453.2125	D	300
			M 3	459.625	D	300
			M 4	465.625	D	300
			H	469.9875	D	300
FM	12.5 KHz	TM4	L	406.1125	D	300
			M 1	430.1125	D	300
			M 2	453.2125	D	300
			M 3	459.625	D	300
			M 4	465.625	D	300
			H	469.9875	D	300
Test Results			PASS			

Remark:

2. Please refer to following plots.



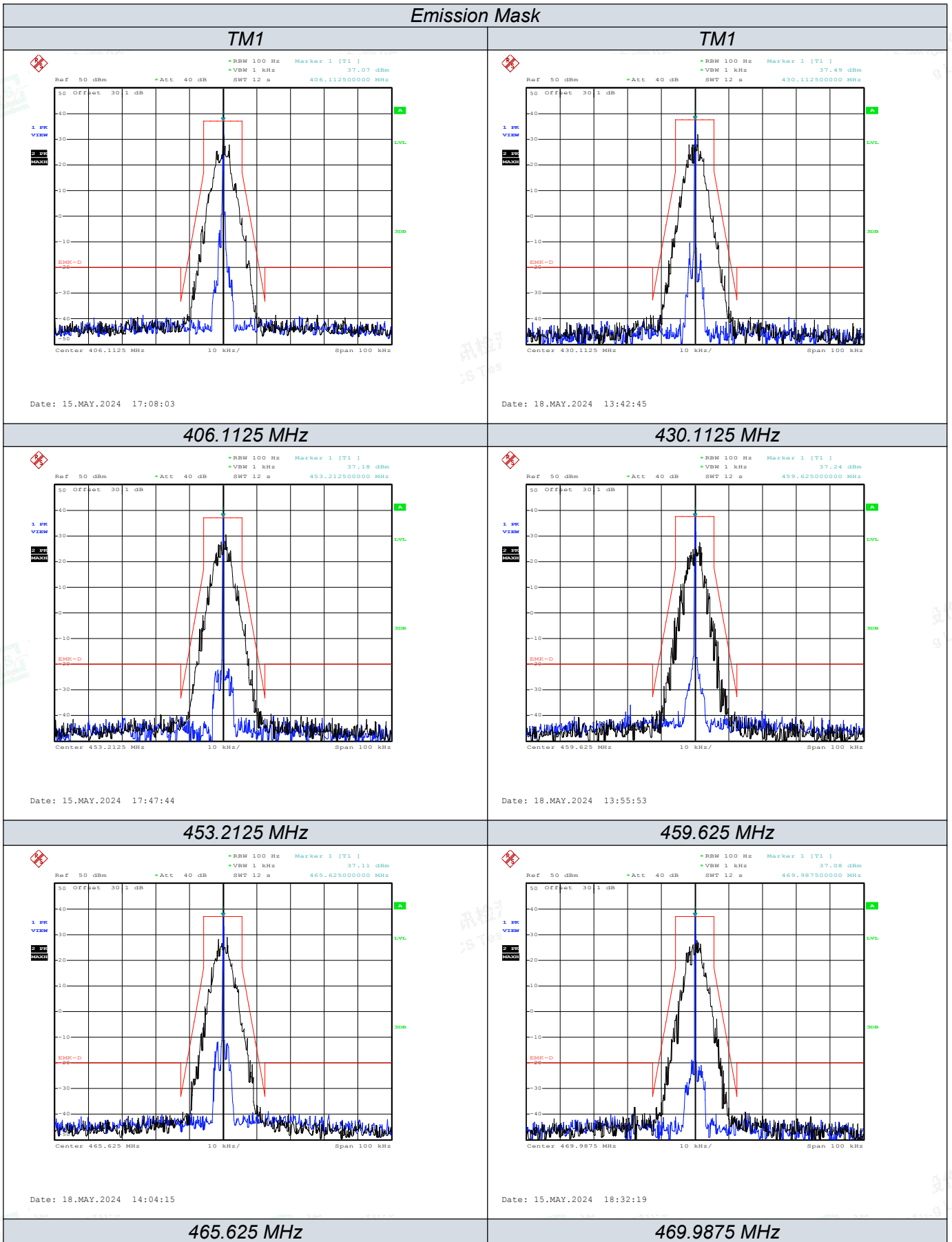

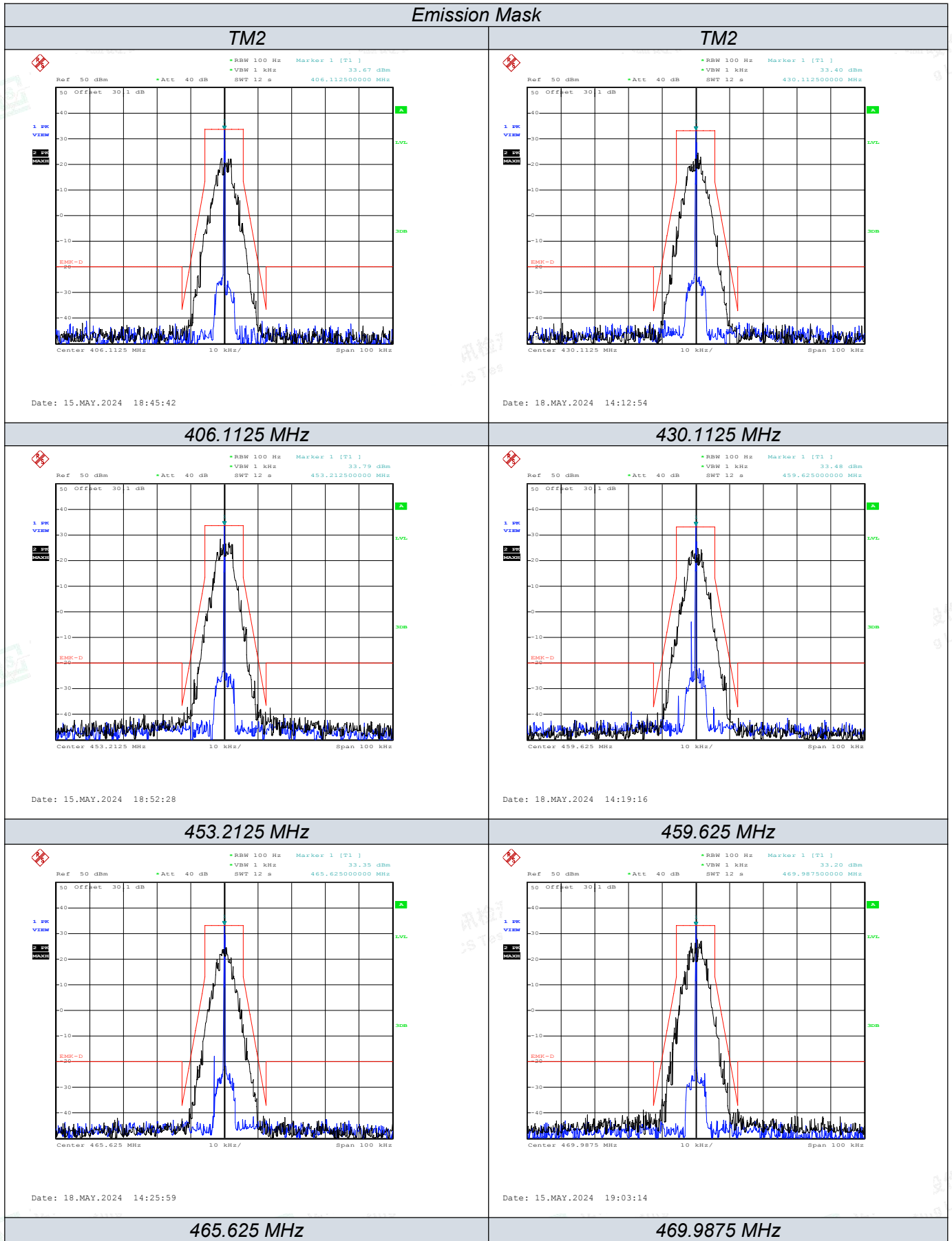

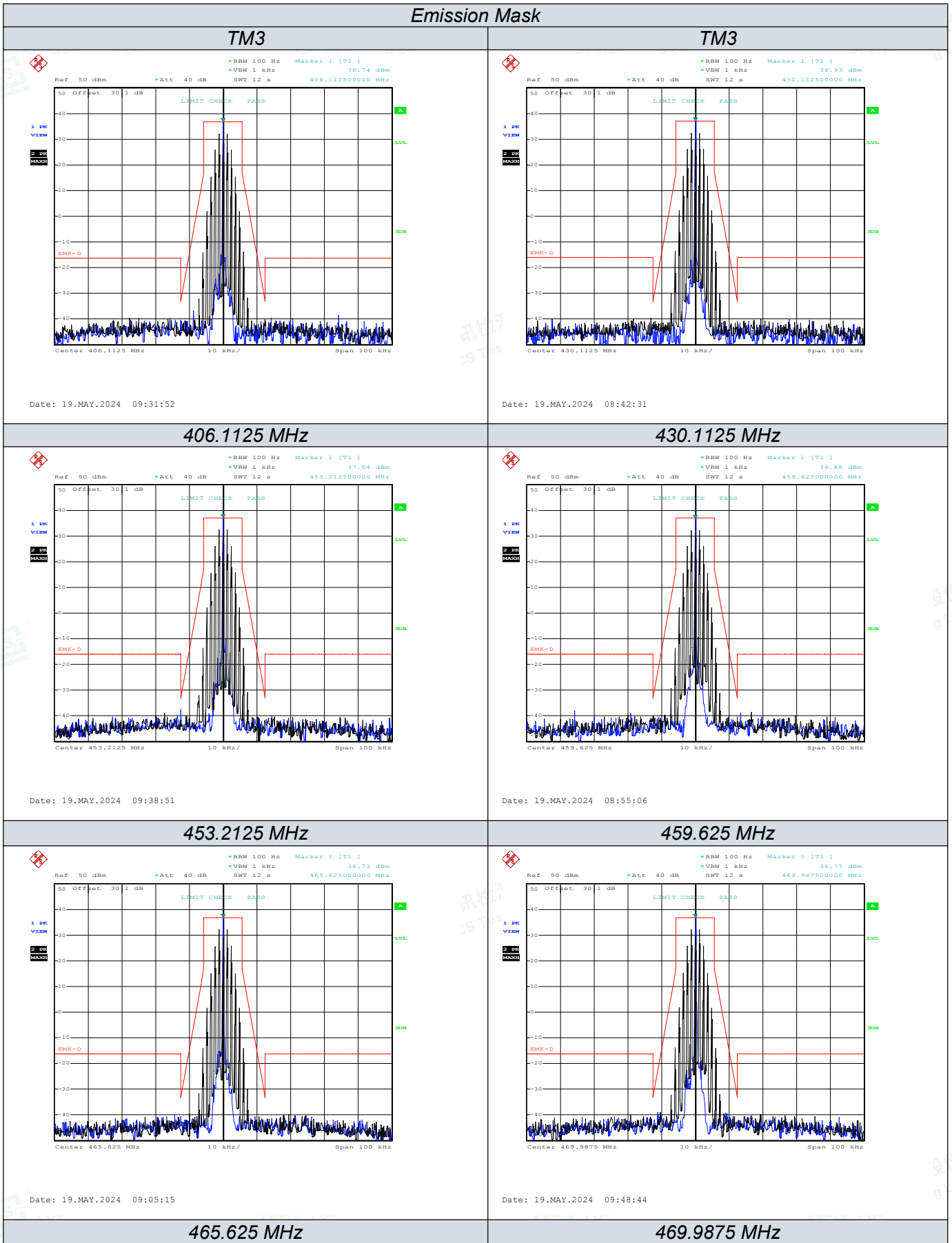

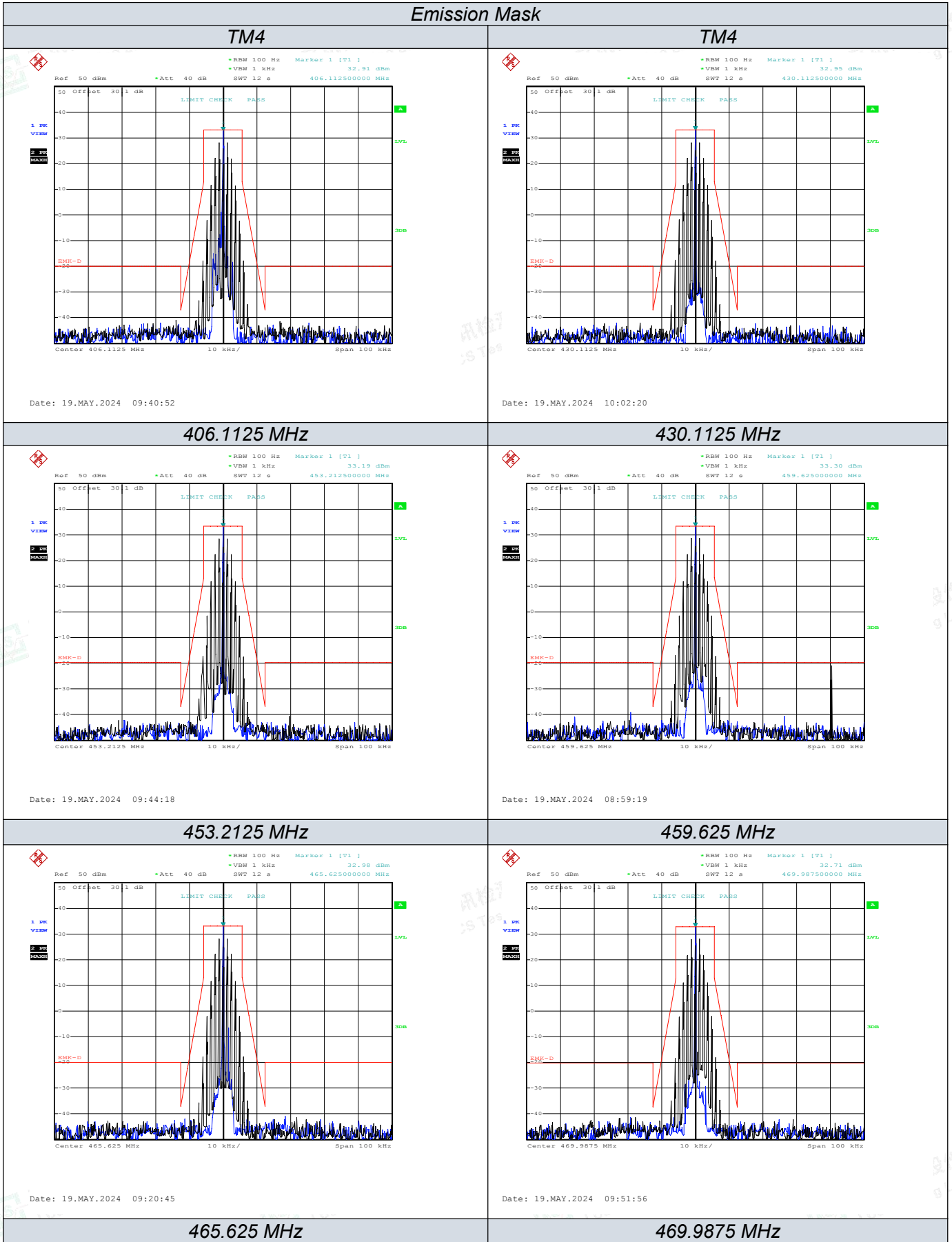

5.3. Transmitter Radiated Spurious Emission

5.3.1 Test Applicable

According to the ANSI C63.26:2015 test method, and according to Section 90.210, the power of each unwanted emission shall be less than Transmitted Power as specified below for transmitters designed to operate with 12.5 KHz channel bandwidth:

- 1 On any frequency removed from the centre of the authorized bandwidth f_0 to 5.625 KHz removed from f_0 : Zero dB
- 2 On any frequency removed from the centre of the authorized bandwidth by a displacement frequency (f_d in KHz) f_0 of more than 5.625 KHz but no more than 12.5 KHz: At least 7.27dB
- 3 On any frequency removed from the centre of the authorized bandwidth by a displacement frequency (f_d in KHz) f_0 of more than 12.5 KHz: At least $50+10 \log (P)$ dB or 70 dB, whichever is lesser attenuation.

For transmitters designed to transmit with 25 KHz channel separation and equipped with an audio low-pass filter, the power of any emission must be attenuated below the unmodulated carrier power (P) as following:

- 1 On any frequency removed from the assigned frequency by more than 50 percent, but no more than 100 percent of the authorized bandwidth: At least 25 dB.
- 2 On any frequency removed from the assigned frequency by more than 100 percent, but no more than 250 percent of the authorized bandwidth: At least 35 dB.
- 3 On any frequency removed from the assigned frequency by more than 250 percent of the authorized bandwidth: At least $43+10\log (P)$ dB.

5.3.2 Test Configuration

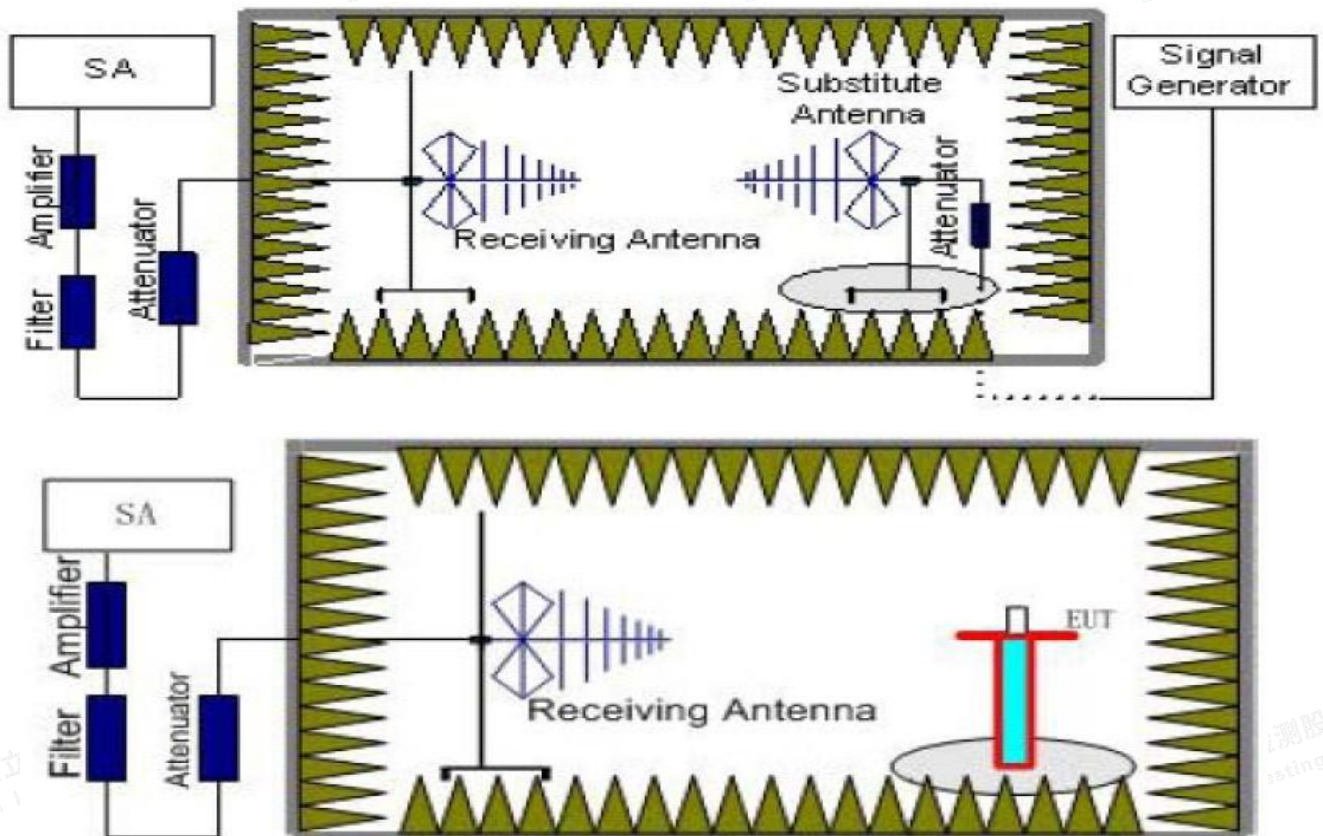

5.3.3 Test Arrangement

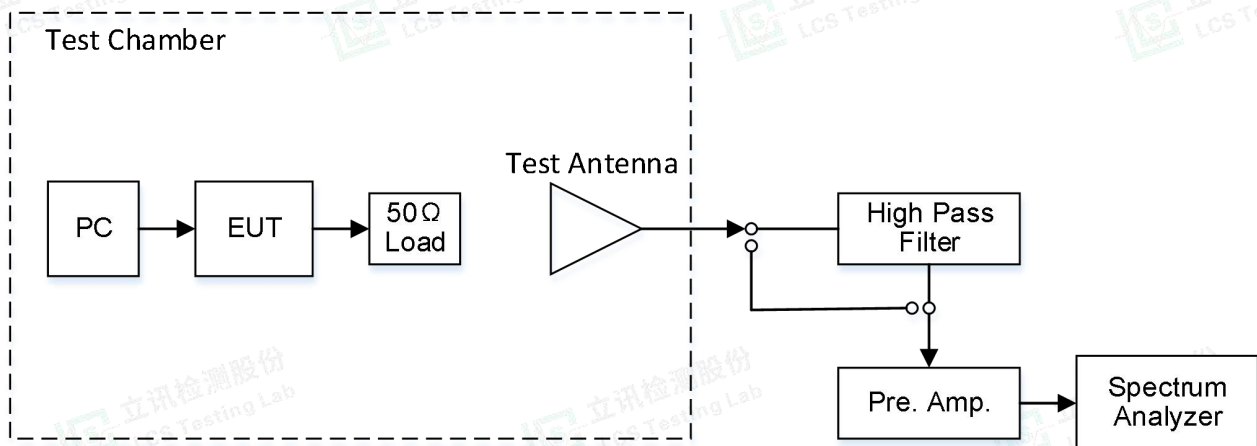

5.3.4 Test Procedure

1. EUT was placed on a 1.50 meter high non-conductive stand at a 3 meter test distance from the receive antenna. A receiving antenna was placed on the antenna mast 3 meters from the EUT for emission measurements. The height of receiving antenna is 1.50 m. Detected emissions were maximized at each frequency by rotating the EUT through 360° and adjusting the receiving antenna polarization. The radiated emission measurements of all transmit frequencies in six channels were measured with peak detector.
2. A log-periodic antenna or double-ridged waveguide horn antenna shall be substituted in place of the EUT. The log-periodic antenna will be driven by a signal generator and the level will be adjusted till the same power value on the spectrum analyzer or receiver. The level of the spurious emissions can be calculated through the level of the signal generator, cable loss, the gain of the substitution antenna and the reading of the spectrum analyzer or receiver.
3. The EUT is then put into continuously transmitting mode at its maximum power level during the test. Set Test Receiver or Spectrum RBW=1MHz, VBW=3MHz for above 1GHz and RBW=100 KHz, VBW=300 KHz for 30MHz to 1GHz, and the maximum value of the receiver should be recorded as (P_r).
4. The EUT shall be replaced by a substitution antenna. In the chamber, a substitution antenna for the frequency band of interest is placed at the reference point of the chamber. An RF Signal source for the frequency band of interest is connected to the substitution antenna with a cable that has been constructed to not interfere with the radiation pattern of the antenna. A power (P_{Mea}) is applied to the input of the substitution antenna, and adjusts the level of the signal generator output until the value of the receiver reach the previously recorded (P_r). The power of signal source (P_{Mea}) is recorded. The test should be performed by rotating the test item and adjusting the receiving antenna polarization.
5. An amplifier should be connected to the Signal Source output port. And the cable should be connecting between the Amplifier and the Substitution Antenna. The cable loss (P_{cl}), the Substitution Antenna Gain (G_a) and the Amplifier Gain (P_{Ag}) should be recorded after test.

The measurement results are obtained as described below:

$$\text{Power (EIRP)} = P_{Mea} - P_{Ag} - P_{cl} - G_a$$





The measurement results are amending as described below:

$$\text{Power (EIRP)} = P_{\text{Mea}} - P_{\text{cl}} - G_a$$

- 6. This value is EIRP since the measurement is calibrated using an antenna of known gain (2.15 dBi) and known input power.
- 7. ERP can be calculated from EIRP by subtracting the gain of the dipole, $\text{ERP} = \text{EIRP} - 2.15\text{dBi}$.

5.3.5 Limit

Modulation Type: 4FSK

FCC Part 90.210:

For 12.5 kHz bandwidth:

On any frequency removed from the center of the authorized bandwidth by a displacement frequency (f_d in kHz) of more than 12.5 kHz at least:

$$\text{Calculation: Limit (dBm)} = \text{EL} - 50 - 10\log(\text{TP}) = -20 \text{ dBm}$$

Notes: EL is the emission level of the Output Power expressed in dBm.

For 25 kHz bandwidth:

On any frequency removed from the center of the authorized bandwidth by a displacement frequency (f_d in kHz) of more than 62.5 kHz at least:

$$\text{Calculation: Limit (dBm)} = \text{EL} - 43 - 10\log_{10}(\text{TP}) = -13 \text{ dBm}$$

Notes: EL is the emission level of the Output Power expressed in dBm.

- Note: 1. In general, the worst case attenuation requirement shown above was applied.
- 2. The measurement frequency range from 9 KHz to 5 GHz.
 - 3. *** means that the emission level is too low to be measured or at least 20 dB down than the limit.
 - 4. ERP for below 1GHz and EIRP above 1GHz.

5.3.5 Test Results

Temperature	23.8°C	Humidity	54.6%
Test Engineer	Paddi Chen	Test Voltage	Normal Voltage

Remark:

- 1. Measured at TM1 to TM4, recorded worst case at TM1;
- 2. Please refer to following page.
- 3. All the modes have been tested and recorded worst mode in the report.





Modulation Type: 4FSK							
Operation Mode: TM1				Channel Separation:12.5KHz			
Test Frequency:406.1125MHz							
Frequency (MHz)	P _{Mea} (dBm)	Path Loss	Antenna Gain	Correction (dB)	Peak EIRP (dBm)	Limit (dBm)	Polarization
820.36	-42.36	5.26	9.88	2.15	-35.586	-20.00	H
1230.42	-53.06	6.11	11.36	2.15	-45.665	-20.00	H
1640.55	-48.42	7.01	11.42	2.15	-41.858	-20.00	H
820.39	-48.85	5.26	9.88	2.15	-42.083	-20.00	V
1230.54	-51.60	6.11	11.36	2.15	-44.202	-20.00	V
1640.64	-57.87	7.01	11.42	2.15	-51.306	-20.00	V

Modulation Type: 4FSK							
Operation Mode: TM1				Channel Separation:12.5KHz			
Test Frequency:430.1125MHz							
Frequency (MHz)	P _{Mea} (dBm)	Path Loss	Antenna Gain	Correction (dB)	Peak EIRP (dBm)	Limit (dBm)	Polarization
820.36	-42.39	5.26	9.88	2.15	-36.25	-20.00	H
1230.47	-53.03	6.11	11.36	2.15	-45.53	-20.00	H
1640.60	-48.49	7.01	11.42	2.15	-41.95	-20.00	H
820.41	-48.81	5.26	9.88	2.15	-42.67	-20.00	V
1230.54	-51.59	6.11	11.36	2.15	-44.09	-20.00	V
1640.57	-57.84	7.01	11.42	2.15	-51.30	-20.00	V

Modulation Type: 4FSK							
Operation Mode: TM1				Channel Separation:12.5KHz			
Test Frequency: 453.2125MHz							
Frequency (MHz)	P _{Mea} (dBm)	Path Loss	Antenna Gain	Correction (dB)	Peak EIRP (dBm)	Limit (dBm)	Polarization
906.37	-42.33	5.39	9.38	2.15	-36.19	-20.00	H
1359.54	-54.13	5.67	11.02	2.15	-46.63	-20.00	H
1812.61	-48.29	6.59	10.98	2.15	-41.75	-20.00	H
906.35	-50.43	5.39	9.38	2.15	-44.29	-20.00	V
1359.48	-52.49	5.67	11.02	2.15	-44.99	-20.00	V
1812.62	-58.27	6.59	10.98	2.15	-51.73	-20.00	V

Modulation Type: 4FSK							
Operation Mode: TM1				Channel Separation:12.5KHz			
Test Frequency: 459.624MHz							
Frequency (MHz)	P _{Mea} (dBm)	Path Loss	Antenna Gain	Correction (dB)	Peak EIRP (dBm)	Limit (dBm)	Polarization
906.33	-42.32	5.39	9.38	2.15	-36.08	-20.00	H
1359.47	-54.11	5.67	11.02	2.15	-46.68	-20.00	H
1812.61	-48.26	6.59	10.98	2.15	-42.01	-20.00	H
906.36	-50.51	5.39	9.38	2.15	-44.33	-20.00	V
1359.42	-52.53	5.67	11.02	2.15	-45.21	-20.00	V
1812.66	-58.29	6.59	10.98	2.15	-51.83	-20.00	V



Shenzhen LCS Compliance Testing Laboratory Ltd.
 Add: 101, 201 Bldg A & 301 Bldg C, Juji Industrial Park Yabianxueziwei, Shajing Street, Baoan District, Shenzhen, 518000, China
 Tel: +(86) 0755-82591330 | E-mail: webmaster@lcs-cert.com | Web: www.lcs-cert.com
 Scan code to check authenticity



Modulation Type: 4FSK							
Operation Mode: TM1				Channel Separation: 12.5KHz			
Test Frequency: 465.625MHz							
Frequency (MHz)	P _{Mea} (dBm)	Path Loss	Antenna Gain	Correction (dB)	Peak EIRP (dBm)	Limit (dBm)	Polarization
939.41	-42.45	5.28	9.37	2.15	-35.679	-20.00	H
1409.01	-53.71	5.62	10.9	2.15	-46.308	-20.00	H
1878.55	-46.44	6.73	10.83	2.15	-39.880	-20.00	H
939.35	-49.63	5.28	9.31	2.15	-42.857	-20.00	V
1408.95	-51.75	5.84	11.01	2.15	-44.353	-20.00	V
1878.58	-56.51	6.75	11.06	2.15	-49.947	-20.00	V

Modulation Type: 4FSK							
Operation Mode: TM1				Channel Separation: 12.5KHz			
Test Frequency: 469.9875MHz							
Frequency (MHz)	P _{Mea} (dBm)	Path Loss	Antenna Gain	Correction (dB)	Peak EIRP (dBm)	Limit (dBm)	Polarization
939.36	-42.47	5.28	9.37	2.15	-36.23	-20.00	H
1408.95	-53.63	5.62	10.9	2.15	-46.20	-20.00	H
1878.60	-46.45	6.73	10.83	2.15	-40.20	-20.00	H
939.41	-49.58	5.28	9.31	2.15	-43.40	-20.00	V
1408.96	-51.76	5.84	11.01	2.15	-44.44	-20.00	V
1878.53	-56.57	6.75	11.06	2.15	-50.11	-20.00	V

Notes:

- 1). Measuring frequencies from 9 KHz~10th harmonic (ex. 26GHz), No emission found between lowest internal used/generated frequency to 30MHz;
- 2). Radiated emissions measured in frequency range from 9 KHz~10th harmonic (ex. 26GHz) were made with an instrument using Peak detector mode;
- 3). Peak EIRP = P_{Mea} + Path Loss + Antenna Gain + Correction Value (2.15).



5.4. Spurious Emission on Antenna Port

5.4.1 Test Applicable

The same as Section 5.3

5.4.2 Test Procedure

The RF output of the EUT was connected to a spectrum analyzer through appropriate attenuation. The resolution bandwidth of the spectrum analyzer was set to 100 kHz. Sufficient scans were taken to show any out of band emission up to 10th. Harmonic for the lower and the highest frequency range. Set RBW 1KHz, VBW 3KHz in the frequency band 9KHz to 150KHz, set RBW 10KHz, VBW 30 KHz in the frequency band 150KHz to 30 MHz, set RBW 100 kHz, VBW 300 kHz in the frequency band 30MHz to 1GHz, while set RBW=1MHz, VBW=3MHz from the 1GHz to 10th Harmonic.

The audio input was set to 0 to get the unmodulated carrier, the resulting picture is print out for each channel separation.

5.4.3 Test Configuration

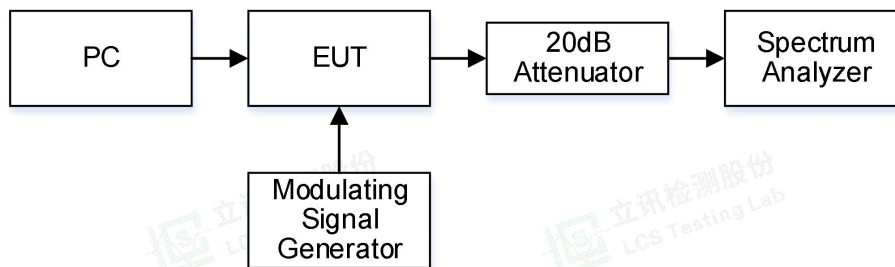

5.4.4 Limit

Modulation Type: 4FSK

FCC Part and 90.210:

For 12.5 kHz bandwidth:

On any frequency removed from the center of the authorized bandwidth by a displacement frequency (f_d in kHz) of more than 12.5 kHz at least:

Calculation: Limit (dBm) = EL - 50 - 10log (TP) = -20 dBm

For 25 kHz bandwidth:

On any frequency removed from the center of the authorized bandwidth by a displacement frequency (f_d in kHz) of more than 62.5 kHz at least:

Calculation: Limit (dBm) = EL - 43 - 10log (TP) = -13 dBm

Notes: EL is the emission level of the Output Power expressed in dBm.

Note: 1. In general, the worst case attenuation requirement shown above was applied.

2. The measurement frequency range from 9 KHz to 6GHz.





5.4.5 Test Results

Temperature	22.6°C	Humidity	53.7%
Test Engineer	Paddi Chen	Test Voltage	Normal Voltage

Operation Mode	Test Channel	Test Frequency (MHz)	Measured Frequency Range	Spurious RF Conducted Emission (dBc)	Limits (dBc)	Verdict
TM1	L	406.1125	9 KHz – 6 GHz	<-20	-20	PASS
	M 1	430.1125	9 KHz – 6 GHz	<-20		
	M 2	453.2125	9 KHz – 6 GHz	<-20		
	M 3	459.625	9 KHz – 6 GHz	<-20		
	M 4	465.625	9 KHz – 6 GHz	<-20		
	H	469.9875	9 KHz – 6 GHz	<-20		

Remark:

1. Measured at TM1 to TM4, recorded worst case at TM1 ;
2. Please refer to following plot.
3. All the modes have been tested and recorded worst mode in the report.





Spurious Emission on Antenna Port TM1 /406.1125 MHz

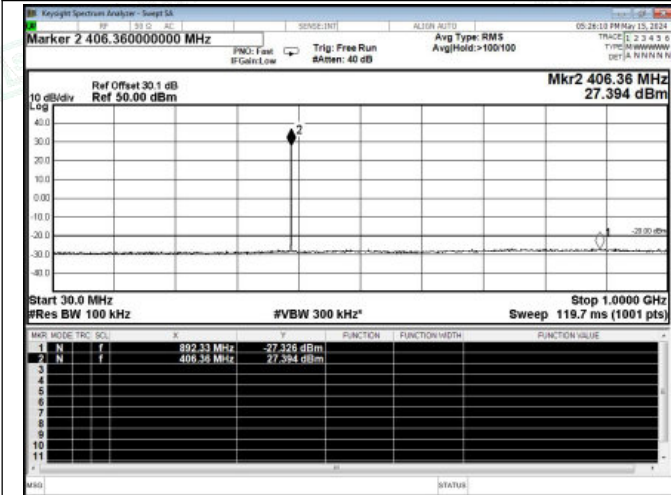

30 MHz – 1 GHz

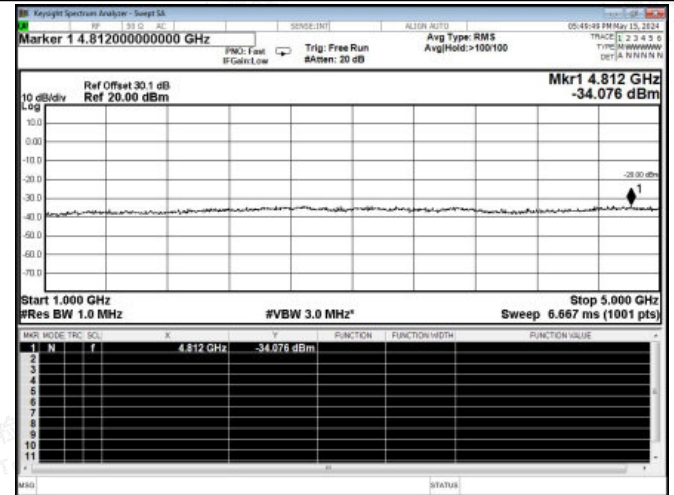

1 GHz – 5 GHz

TM1 /430.1125 MHz

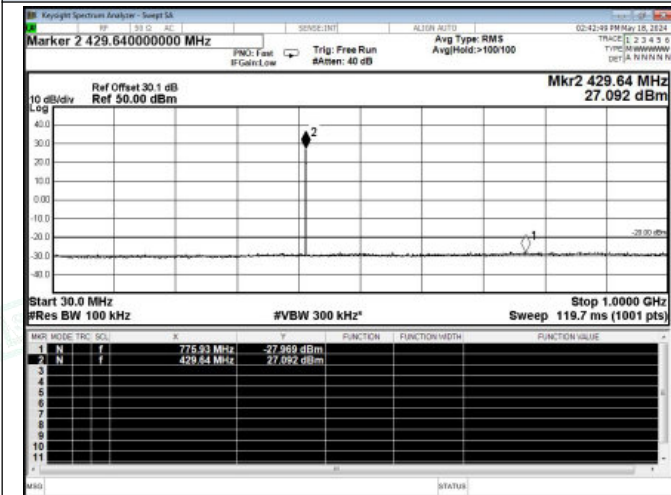

30 MHz – 1 GHz

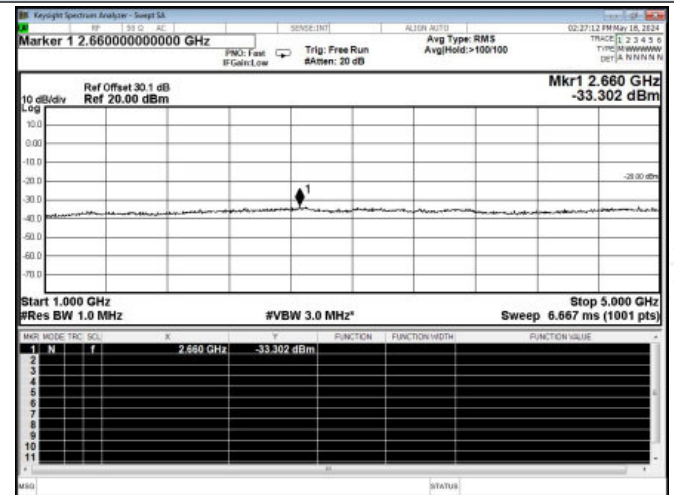

1 GHz – 5 GHz

TM1 /453.2125 MHz

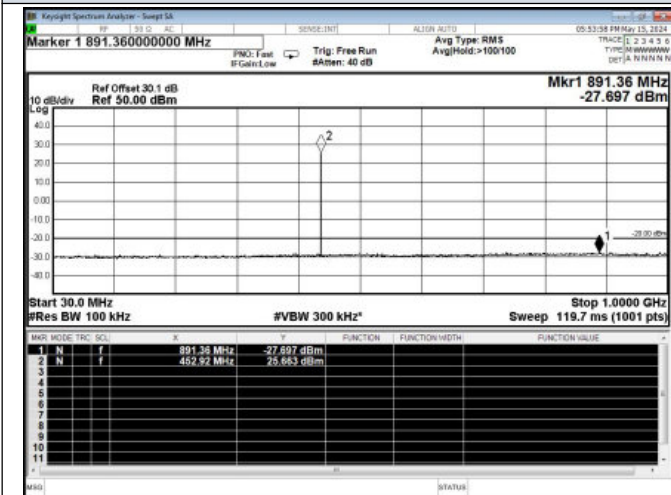

30 MHz – 1 GHz

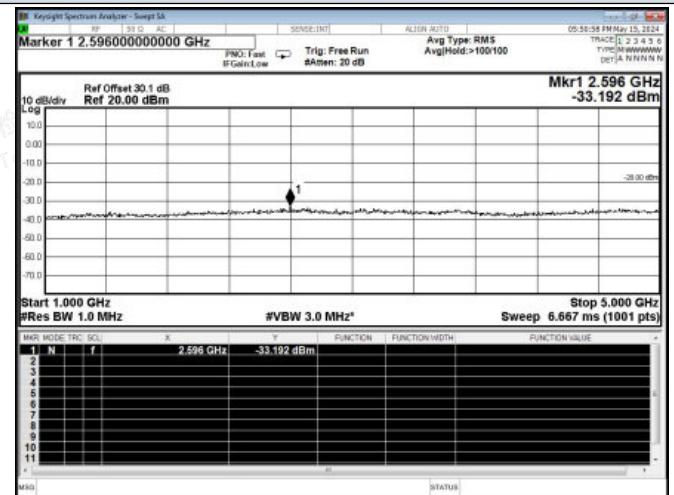

1 GHz – 5 GHz





TM1 /459.625 MHz

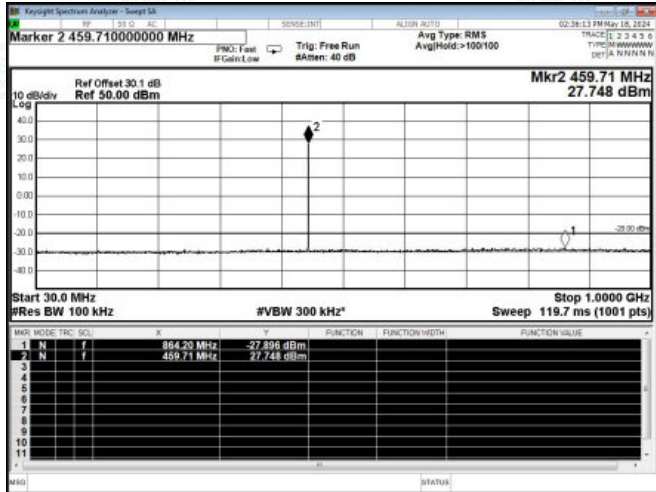

30 MHz – 1 GHz

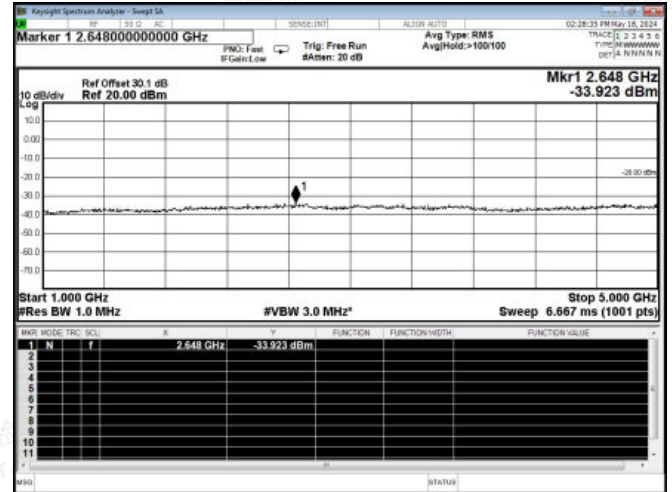

1 GHz – 5 GHz

TM1 /465.625 MHz

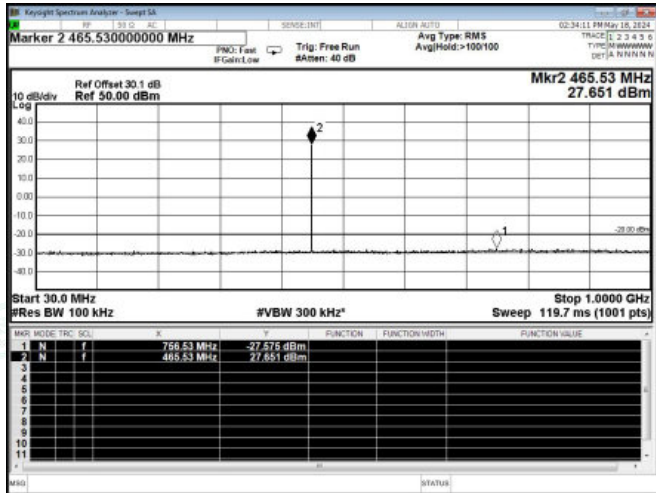

30 MHz – 1 GHz

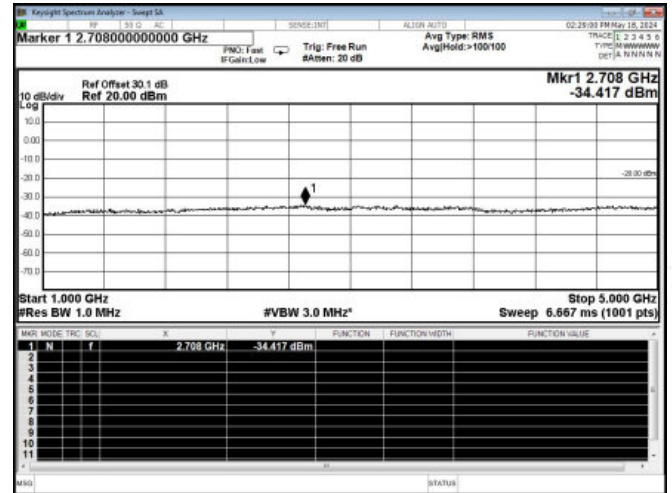

1 GHz – 5 GHz

TM1 /469.9875 MHz

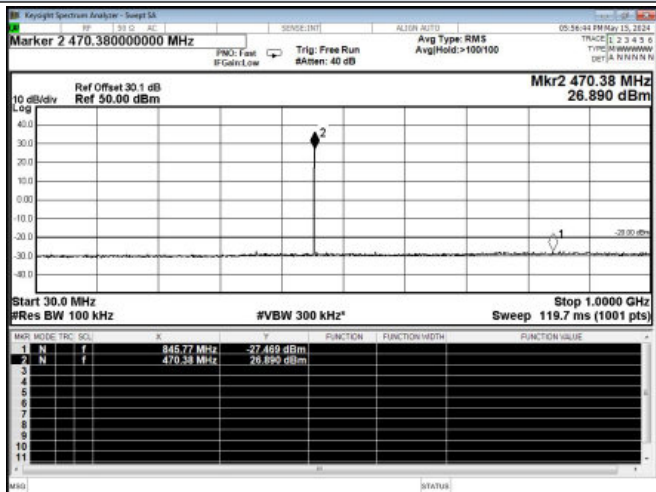

30 MHz – 1 GHz

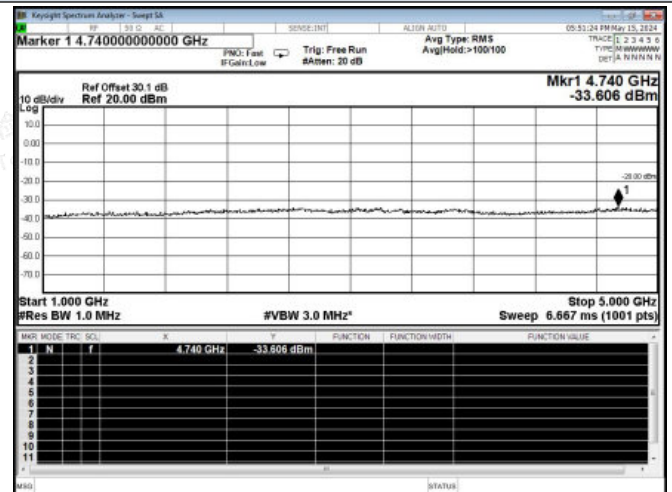

1 GHz – 5 GHz



5.5. Frequency Stability Test

5.5.1 Test Applicable

- 1 According to FCC Part 2 Section 2.1055 (a) (1), the frequency stability shall be measured with variation of ambient temperature from -30°C to +60°C centigrade.
- 2 According to FCC Part 2 Section 2.1055 (e) (2), for battery powered equipment, the frequency stability shall be measured with reducing primary supply voltage to the battery operating end point, which is specified by the manufacture.
- 3 Vary primary supply voltage from 85 to 115 percent of the nominal value.
- 4 According to §90.213, the frequency stability limit is 2.5 ppm for 12.5KHz and 5.0ppm for 25KHz channel separation

5.5.2 Test Procedure

The EUT was set in the climate chamber and connected to an external DC power supply and AC power supply. The RF output was directly connected to Spectrum Analyzer ESCI3. The coupling loss of the additional cables was recorded and taken in account for all the measurements. After temperature stabilization (approx. 20 min for each stage), the frequency for the lower, the middle and the highest frequency range was recorded. For Frequency stability Vs. Voltage the EUT was connected to a DC power supply or AC power supply and the voltage was adjusted in the required ranges. The result was recorded.

5.5.3 Test Configuration

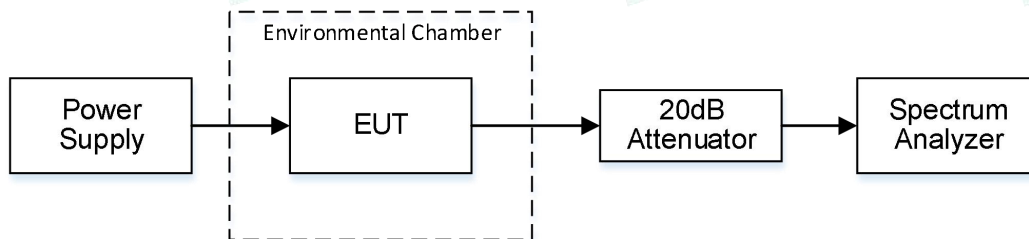

5.5.4 Test Limits

According to 90.213, Transmitters used must have minimum frequency stability as specified in the following table.

Frequency Range	Channel Bandwidth	Frequency Tolerance (ppm)		
		Fixed and Base Station	Mobile Stations	
			> 2W	≤ 2W
150-174MHz	6.25	1.0	2.0	2.0
	12.5	2.5	5.0	5.0
	25	5.0	5.0	50.0*
421-512MHz	6.25	0.5	1.0	1.0
	12.5	1.5	2.5	2.5
	25	2.5	5.0	5.0

* Stations operating in the 154.45 MHz or the 173.2 to 173.4 MHz bands must have a frequency stability of 5 ppm.

* Paging transmitters operating on paging-only frequencies must operate with frequency stability of 5 ppm in the 150-174 MHz band and 1.5 ppm in the 421-512 MHz band.





5.5.5 Test Results

Temperature	23.8°C	Humidity	54.6%
Test Engineer	Paddi Chen	Test Voltage	Normal Voltage

Operation Mode	Channel Separation	Test conditions		Frequency error (ppm)		
		Voltage(V)	Temp(°C)	406.1125	430.1125	453.2125
TM1	12.5KHz	7.2 V	-30	0.008	-0.001	0.015
			-20	-0.011	-0.002	-0.010
			-10	0.003	-0.002	-0.003
			0	0.006	0.005	-0.004
			10	-0.005	0.009	-0.007
			20	-0.003	0.001	-0.005
			30	-0.001	0.023	-0.013
			40	-0.009	-0.015	0.007
			50	0.013	0.010	-0.015
			6.12 (85% Rated)	20	0.008	-0.013
		8.28(115% Rated)	20	-0.006	0.005	-0.010
Limit			2.5ppm			
Test Results			PASS			

Operation Mode	Channel Separation	Test conditions		Frequency error (ppm)		
		Voltage(V)	Temp(°C)	459.625	465.625	469.9875
TM1	12.5KHz	7.2 V	-30	-0.002	0.006	0.014
			-20	-0.001	0.000	0.004
			-10	0.015	-0.010	-0.010
			0	0.007	-0.007	-0.013
			10	-0.007	0.000	-0.002
			20	0.009	-0.003	0.003
			30	-0.008	0.009	0.007
			40	-0.010	0.004	-0.002
			50	0.010	0.000	-0.001
			6.12 (85% Rated)	20	-0.003	0.004
		8.28(115% Rated)	20	-0.016	-0.011	-0.008
Limit			2.5ppm			
Test Results			PASS			

Remark:

1. Measured at TM1 to TM4, recorded worst case at TM1.
2. All the modes have been tested and recorded worst mode in the report.



5.6. Transient Frequency Behavior

5.6.1 Test Applicable

Section 90.214

Transient frequencies must be within the maximum frequency difference limits during the time intervals indicated:

Time intervals ^{1, 2}	Maximum frequency difference ³	All equipment	
		1500 to 174 MHz	421 to 512 MHz
Transient Frequency Behavior for Equipment Designed to Operate on 25KHz Channels			
t ₁ ⁴	± 25.0KHz	5.0ms	10.0ms
t ₁	± 12.5KHz	20.0ms	25.0ms
t ₃ ⁴	± 25.0KHz	5.0ms	10.0ms
Transient Frequency Behavior for Equipment Designed to Operate on 12.5KHz Channels			
t ₁ ⁴	± 12.5KHz	5.0ms	10.0ms
t ₁	± 6.25KHz	20.0ms	25.0ms
t ₃ ⁴	± 12.5KHz	5.0ms	10.0ms
Transient Frequency Behavior for Equipment Designed to Operate on 6.25KHz Channels			
t ₁ ⁴	± 6.25KHz	5.0ms	10.0ms
t ₁	± 3.125KHz	20.0ms	25.0ms
t ₃ ⁴	± 6.25KHz	5.0ms	10.0ms

1. t_{on} is the instant when a 1 KHz test signal is completely suppressed, including any capture time due to phasing. t₁ is the time period immediately following t_{on}.
- t₂ is the time period immediately following t₁.
- t₃ is the time period from the instant when the transmitter is turned off until t_{off}.
- t_{off} is the instant when 1 KHz test signal starts to rise.
2. During the time from the end of t₂ to the beginning of t₃, the frequency difference must not exceed the limits specified in 90.213.
3. Difference between the actual transmitter frequency and the assigned transmitter frequency.
4. If the transmitter carrier output power rating is 6 watts or less, the frequency difference during this time period may exceed the maximum frequency for this time period.

5.6.2 Test Configuration

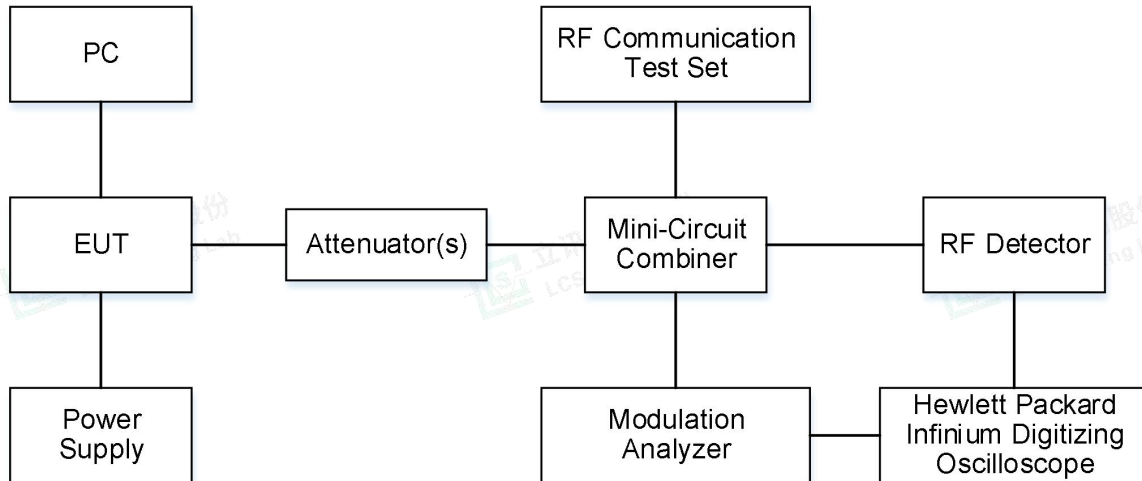

5.6.3 Test Procedure

According to TIA/EIA-603 2.2.19 requirement.





5.6.4 Test Results

Temperature	23.8°C	Humidity	54.6%
Test Engineer	Paddi Chen	Test Voltage	Normal Voltage

Measured at TM1 to TM4, recorded worst case at TM1.

Modulation Type: 4FSK

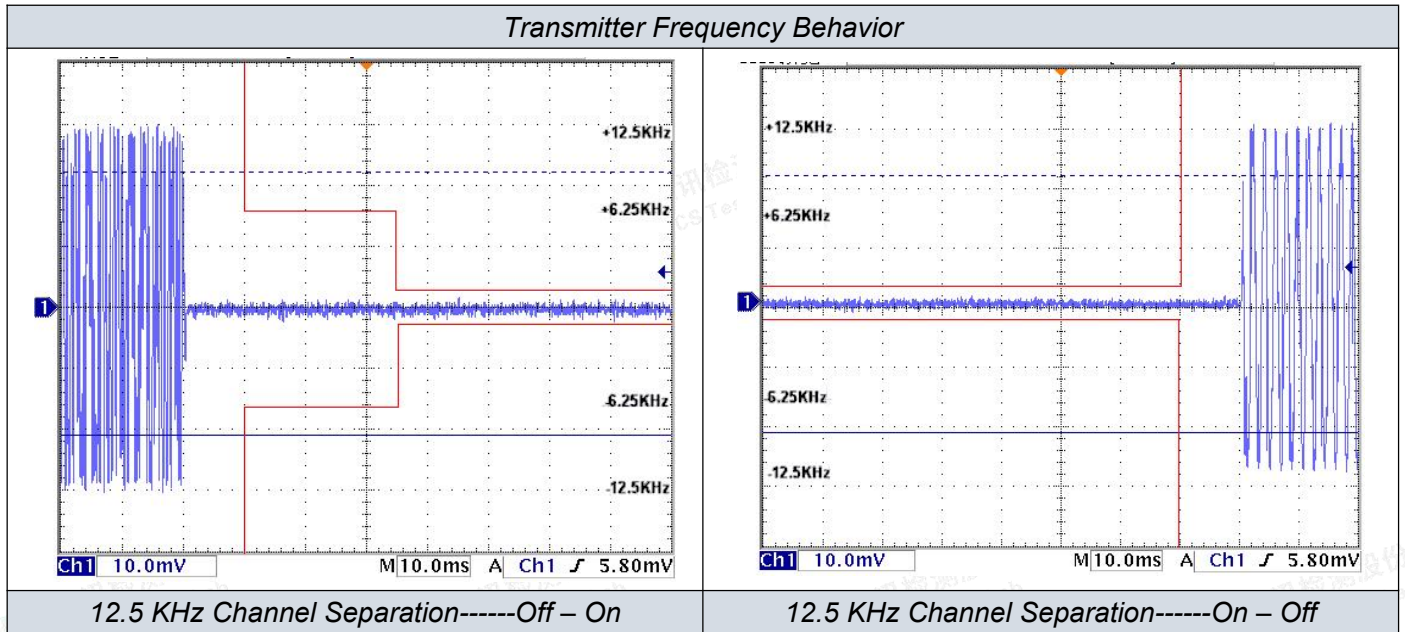



5.7. FCC §2.1047 - MODULATION CHARACTERISTIC

5.7.1 Test Applicable

Section 90.214

Transient frequencies must be within the maximum frequency difference limits during the time intervals indicated:

Applicable Standard

FCC §2. 1047

(a) Equipment which utilizes voice modulated communication shall show the frequency response of the audio modulating circuit over a range of 100 to 5000 Hz. for equipment which is required to have a low pass filter, the frequency response of the filter, or all of the circuitry installed between the modulation limited and the modulated stage shall be supplied.

(b) Equipment which employs modulation limiting, a curve showing the percentage of modulation versus the modulation input voltage shall be supplied.

Test Procedure

Test Method: TIA-603-E 2.2.3

Test Data

Environmental Conditions

Temperature	23.8°C	Humidity	54.6%
Test Engineer	Paddi Chen	Test Voltage	Normal Voltage

Test Mode: Transmitting

Test Result: Compliance. please refer to the following tables.





Audio Frequency Response – High Power

12.5kHz:

Carrier Frequency: 453.2125 MHz

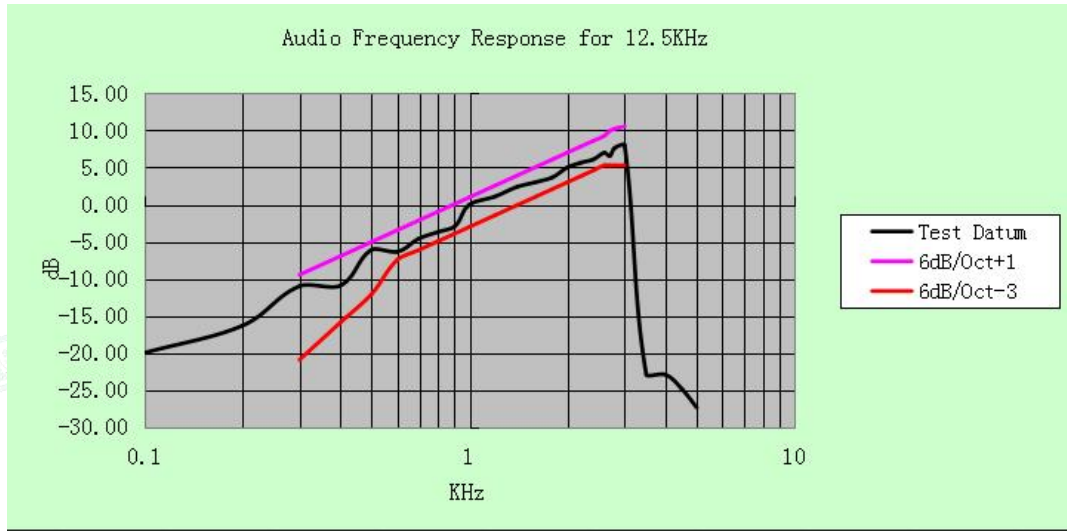



MODULATION LIMITING – High Power

12.5kHz

Carrier Frequency: 453.2125 MHz

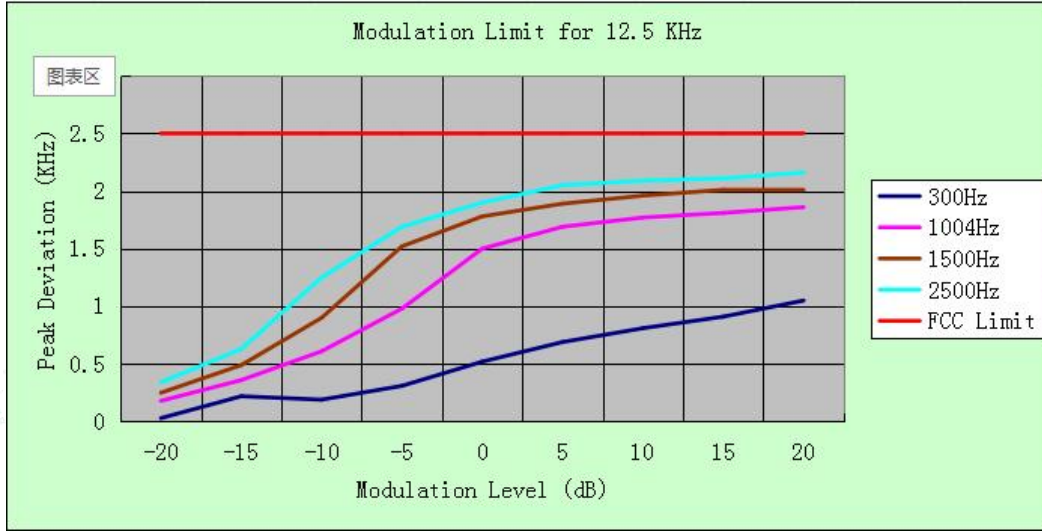



6. LIST OF MEASURING EQUIPMENT

Item	Equipment	Manufacturer	Model No.	Serial No.	Cal Date	Due Date
1	MXA Signal Analyzer	Agilent	N9020A	MY49100060	2023-10-18	2024-10-17
2	DC Power Supply	Agilent	E3642A	N/A	2023-10-18	2024-10-17
3	Temperature & Humidity Chamber	GUANGZHOU GOGNWEN	GDS-100	70932	2023-10-05	2024-10-04
4	Signal Analyzer	R&S	SL3	101507	2023-06-09	2024-06-08
5	MXG Vector Signal Generator	Agilent	E4438C	MY42081396(6G)	2023-10-18	2024-10-17
6	ESG Vector Signal Generator	Agilent	E4438C	MY49072627(3G)	2023-06-09	2024-06-08
8	Audio Analyzer	R&S	UPV	1146.2003K02-10 1721-UW	2023-10-18	2024-10-17
9	EMI Test Software	Farad	EZ	/	N/A	N/A
7	3m Full Anechoic Chamber	MRDIANZI	FAC-3M	MR009	2022-08-17	2025-08-16
10	Positioning Controller	Max-Full	MF7802BS	MF780208586	N/A	N/A
11	Active Loop Antenna	SCHWARZBECK	FMZB 1519B	00005	2021-08-29	2024-08-28
12	By-log Antenna	SCHWARZBECK	VULB9163	9163-470	2021-09-12	2024-09-11
13	Horn Antenna	SCHWARZBECK	BBHA 9120D	9120D-1925	2021-09-05	2024-09-04
14	EMI Test Receiver	R&S	ESR 7	101181	2023-08-15	2024-08-14
15	Low-frequency amplifier	SchwarzZBECK	BBV9745	00253	2023-10-18	2024-10-17
16	High-frequency amplifier	JS Denki Pte	PA0118-43	JSPA21009	2023-10-18	2024-10-17
17	High-Pass Filter	Anritsu	MP526D	6220878392	2023-06-09	2024-06-08
18	Combiner	eastsheep	SHWLPD2-52 500S	/	2023-10-18	2024-10-17
19	6dB Attenuator	/	100W/6dB	1172040	2023-06-09	2024-06-08
20	3dB Attenuator	/	2N-3dB	/	2023-10-18	2024-10-17
21	Storage Oscilloscope	Tektronix	TDS3052	B017447	2023-06-09	2024-06-08
22	RF Cable-R03m	Jye Bao	RG142	CB021	2023-06-09	2024-06-08
23	RF Cable-HIGH	SUHNER	SUCOFLEX 106	03CH03-HY	2023-06-09	2024-06-08



7. TEST SETUP PHOTOGRAPHS OF EUT

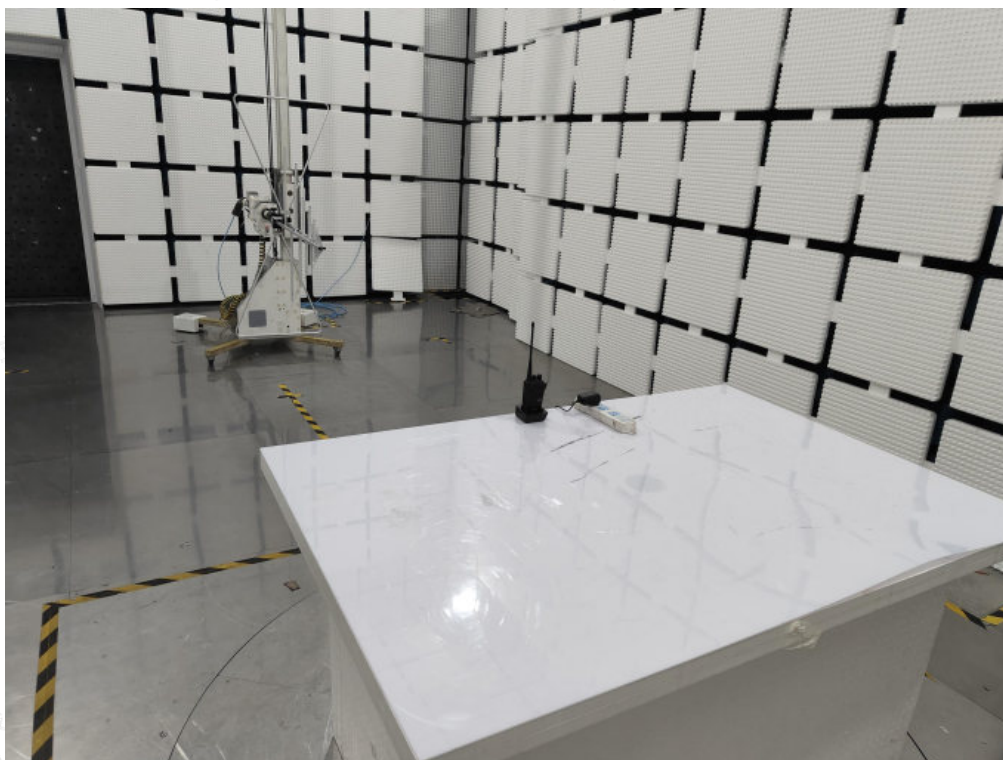

Fig.1 (below 1GHz)



Fig.2 (Above 1GHz)





8. EXTERIOR PHOTOGRAPHS OF THE EUT

Please refer to separated files for External Photos of the EUT.

9. INTERIOR PHOTOGRAPHS OF THE EUT

Please refer to separated files for Internal Photos of the EUT.

-----THE END OF REPORT-----

