

REVISION HISTORY

REV	DESCRIPTION	BY/DATE	ECO NO.	APPROVED
AAA	RELEASE TO PRODUCTION FROM JC1 DRAWING REV. 2, 1857637 REV. 2, 1855992 REV. 1, 1376685 REV. 4 AND 1723478 REV. 4	CDP 12/16/13	-	-

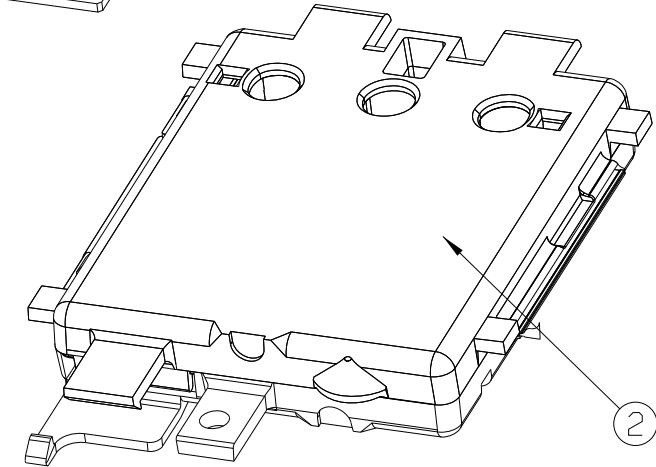

ISOMETRIC REFERENCE VIEW

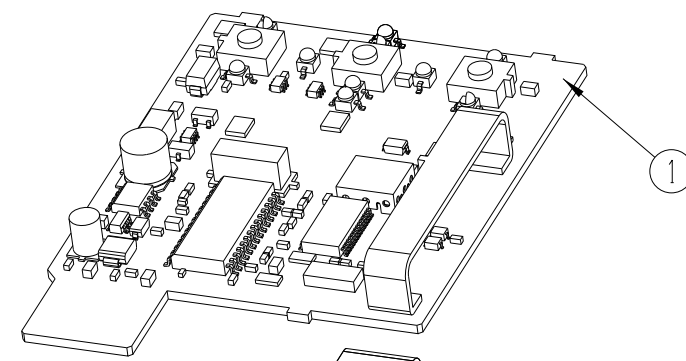
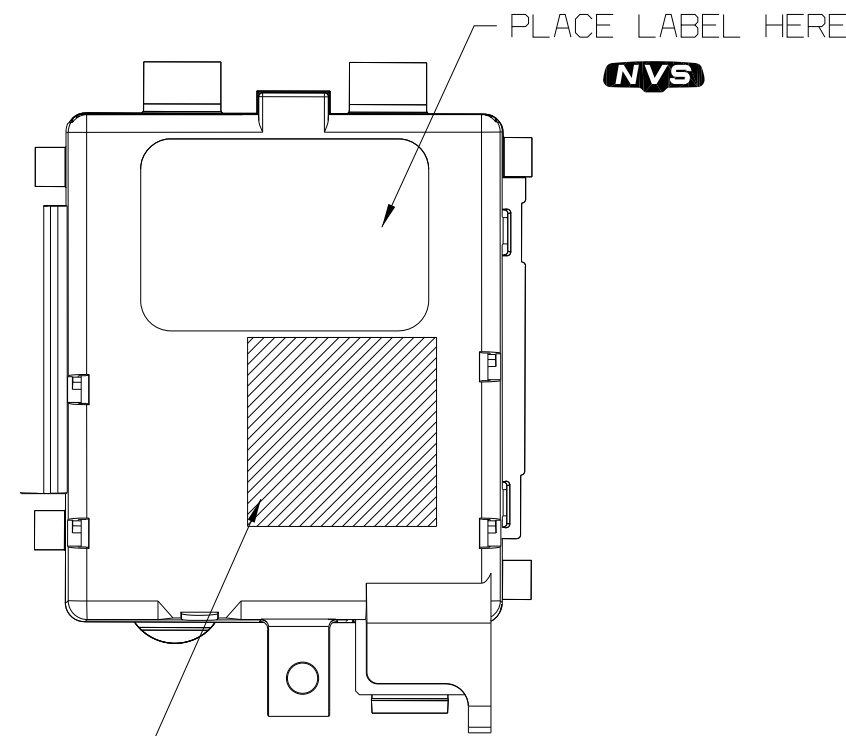

PRE-ASSEMBLED
FOAM PAD

QTY	QTY	QTY	QTY	ITEM	DESCRIPTION	GENTEX PART NO.
1	1	1	1	4	LABEL, BAR CODE 4X6 (NOT SHOWN)	375-0369-000
1	1	1	1	3	LBL, STOCK 1.0 x 1.5	375-0765-000
1	1	1	1	2	HSG ASM, HMLK XEBRA, WITH FOAM	625-0890-000
1					SA PCB, HL GM ZETA QT	705-2303-001
	1			1	SA PCB, HL4 VISOR MY09	605-4734-001
		1		1	SA PCB, HL4 VISOR	605-4735-001
			1	1	SA PCB, HMLK4 FORD 409252MIVIS	605-4725-001

QTY	QTY	QTY	QTY	ITEM	DESCRIPTION	GENTEX ASSY NO.	REV.
4	3	2	1	ITEM	FINAL ASM, GM ZETA QT HLK	960-0056	AAA
					FINAL ASM, HMLK4 VISOR MY09	960-0055	AAA
					FINAL ASM, HMLK4 VISOR	960-0053	AAA
					FINAL ASM, HMLK4 VISOR MY09	960-0049	AAA

NOTES:

- INDIVIDUAL COMPONENTS ON PCB ASSEMBLY ARE FOR REFERENCE ONLY.
- ADHESIVE LABEL FORMAT AND INFORMATION IS TO MATCH AS SHOWN IN THE LABEL VIEW(S) AND BOM.
- ASSEMBLY MUST COMPLY WITH FMVSS 302 & CMVSS 302.
- THE BAR CODE CONTAINS THE FOLLOWING; 'PL' FOLLOWED BY AN 8-DIGIT BAR CODE. AN EXAMPLE IS BELOW; PL12345678
- ASSEMBLY MUST COMPLY TO TEST SPECIFICATION TDE-ELE-100.
- ENCLOSE THE PCB IN THE HOUSING.
- LABEL SHALL NOT COVER OPENINGS IN THE HOUSING, OVERLAP THE FOAM OR COVER OTHER FUNCTIONAL ITEMS.

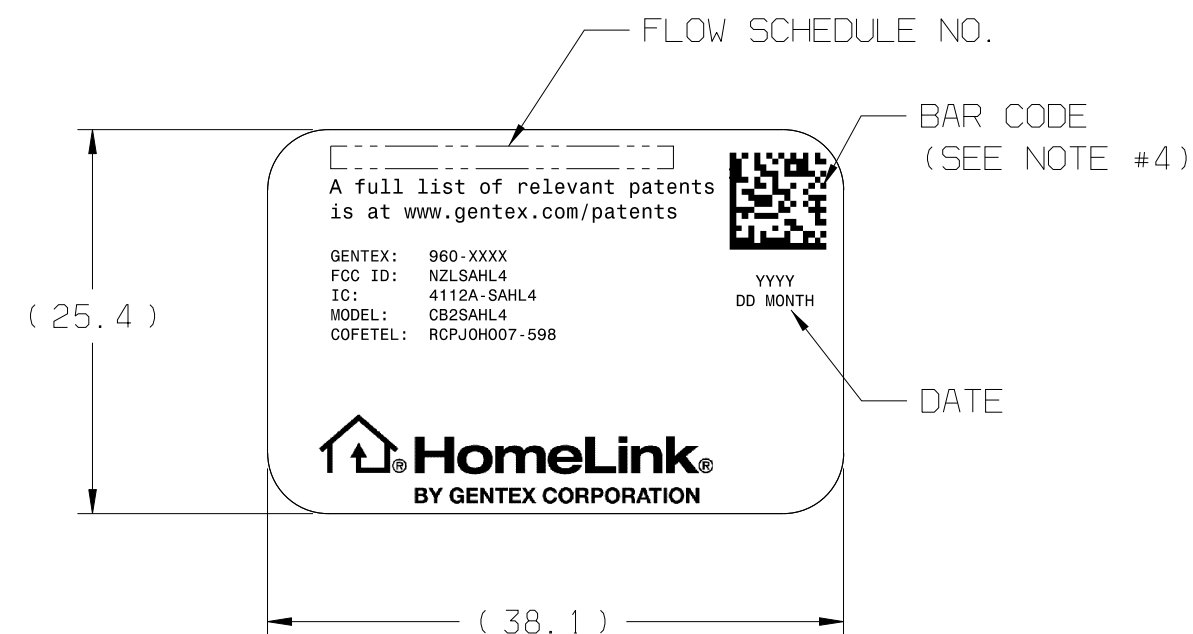

LABEL VIEW
SCALE: 2:1

GENTEX CORPORATION
600 NORTH CENTENNIAL ST
ZEELAND, MICHIGAN 49464
(616) 772-1800

TITLE
FINAL ASM, HMLK4, VISOR

NVS SPECIFIES FEATURES REQUIRING SPECIAL CONSIDERATION. SEE CONTROL PLAN. INTERPRET DIMENSIONS AND TOLERANCE PER ASME Y14.5M - 1994		SIZE D	DWG NO. 960-F	REV AAA
THIRD ANGLE PROJECTION 		MATERIAL SEE COMP DWGS.	MASS (CALCULATED) 33.2 g	
SCALE 1:1 & AS NOTED		DRAWN BY CPOLLACK	DATA FORMAT CATIA V5	
		DATE 12/10/2013	SHEET 1 OF 1	