

TEST REPORT

Report No.: SHE20100017-02HE

Date: 2021-03-15

Page 1 of 53

Applicant : Trimble Europe BV.
Address of Applicant : Industrieweg 187a, 5683 CC Best, Netherlands

Product Name : Rugged Smart Phone
Model No. : TDC600_2, MobileMapper60_2
Sample No. : E20100017-01 #16
E20100017-01 #01
FCC ID : NZI-11705920
ISED Number : 9288A-11705920

Standards : FCC CFR47 Part 15, Subpart C
RSS-Gen (Issue 5, March 2019)
RSS-247 (Issue 2, February 2017)

Date of Receipt : 2021-01-26
Date of Test : 2021-01-26 ~ 2021-03-15
Date of Issue : 2021-03-15

Remark:

This report details the results of the testing carried out on one sample, the results contained in this report do not relate to other samples of the same product. The manufacturer should ensure that all products in series production are in conformity with the product sample detailed in this report.

Prepared by: Jennifer Zhou
(Jennifer Zhou)

Reviewed by: Oliver Xiang
(Oliver Xiang)

Approved by: Guoyou Chi
(Authorized signatory: Guoyou Chi)

TEST REPORT

Report No.: SHE20100017-02HE

Date: 2021-03-15

Page 2 of 53

Contents

1	GENERAL INFORMATION	3
1.1	TESTING LABORATORY	3
1.2	DETAILS OF APPLICATION	3
1.3	DETAILS OF EUT	4
1.4	TEST METHODOLOGY	4
2	TEST CONDITION	5
2.1	ENVIRONMENTAL CONDITIONS	5
2.2	EQUIPMENT LIST	5
2.3	MEASUREMENT UNCERTAINTY	5
3	TEST SET-UP AND OPERATION MODES	6
3.1	DETAILS OF TEST MODE	6
3.2	SPECIAL ACCESSORIES AND AUXILIARY EQUIPMENT	6
3.3	SUPPORT SOFTWARE	6
3.4	TEST SETUP DIAGRAM	7
4	TEST RESULTS	9
4.1	TRANSMITTER REQUIREMENT & TEST SUITES	9
4.1.1	<i>Antenna Requirement</i>	9
4.1.2	<i>Maximum Conducted Output Power and E.I.R.P.</i>	10
4.1.3	<i>20dB Bandwidth and 99% Bandwidth</i>	16
4.1.4	<i>Conducted Spurious Emission & Authorized-band band-edge</i>	20
4.1.5	<i>Spurious Emission</i>	37
4.1.6	<i>Band Edge (Restricted-band band-edge)</i>	38
4.1.7	<i>Hopping Frequency Separation</i>	39
4.1.8	<i>Number of Hopping Frequency</i>	41
4.1.9	<i>Time of Occupancy</i>	43
4.2	MAINS EMISSIONS	47
4.2.1	<i>Conducted Emission on AC Mains</i>	47
5	APPENDIXES	50
5.1	PHOTOGRAPHS OF THE SAMPLE	50
5.2	SET-UP FOR CONDUCTED EMISSIONS	52
5.3	SET-UP FOR CONDUCTED RF TEST AT ANTENNA PORT	52
5.4	SET-UP FOR SPURIOUS EMISSIONS BELOW 1GHZ	53
5.5	SET-UP FOR SPURIOUS EMISSIONS ABOVE 1GHZ	53

TEST REPORT

Report No.: SHE20100017-02HE

Date: 2021-03-15

Page 3 of 53

1 General Information

1.1 Testing Laboratory

Company Name	ICAS Testing Technology Service (Shanghai) Co., Ltd.
Address	No.1298 Pingan Rd, Minhang District, Shanghai, China
Telephone	0086 21-51682999
Fax	0086 21-54711112
Homepage	www.icasiso.com

1.2 Details of Application

Applicant Company Name	Trimble Europe BV.
Address	Industrieweg 187a, 5683 CC Best, Netherlands
Contact Person	Joel Hamberg Magnusson
Telephone	+46764953125
Email	joel_hambergmagnusson@trimble.com
Manufacturer Company Name	Trimble Europe BV.
Address	Industrieweg 187a, 5683 CC Best, Netherlands
Factory Company Name	Shenzhen UniStrong Science & Technology Co., Ltd.
Address	B,4-4Factory, Zhengcheng Road, FuyongBaoan District, Shenzhen, China

TEST REPORT

Report No.: SHE20100017-02HE

Date: 2021-03-15

Page 4 of 53

1.3 Details of EUT

Product Name	Rugged Smart Phone
Brand Name	Trimble, Spectra Geospatial
Test Model No.	TDC600_2
Series Model No.	TDC600_2; MobileMapper60_2
Description of Model name differentiation	All model are same with electrical paramters and Internal circuit structure, but only different on model name, brand name and colors and software version.
FCC ID	NZI-11705920
ISED Number	9288A-11705920
Mode of Operation	Bluetooth BR/EDR
Frequency Range	2400MHz ~ 2483.5MHz
Number of Channels	79 (at intervals of 1 MHz)
Modulation Type	GFSK, $\pi/4$ -DQPSK, 8-DPSK
Antenna Type	Internal Antenna
Antenna Gain	3.14 dBi
Extreme Temperature Range	-20°C ~ +55°C
Test Voltage	DC 3.8V
Hardware version	V1.0
Software version	TDC600_2.53.10.14 (model:TDC600_2) MM60_2.53.10.05 (model: MobileMapper60_2)
Test SW Version	BL410_R;BL410_E
RF power setting in TEST SW	QRCT

1.4 Test Methodology

47 CFR Part 15, Subpart C (10-1-16 Edition)	Miscellaneous Wireless Communications Services
FCC PUBLIC NOTICE DA 00-705 (Mar.30, 2000)	Filling and Measurement Guidelines for Frequency Hopping Spread Spectrum Systems
RSS-Gen (Issue 5, March 2019)	General Requirements for Compliance of Radio Apparatus
RSS-247 (Issue 2, February 2017)	Digital Transmission Systems (DTSs), Frequency Hopping Systems (FHSs) and Licence-Exempt Local Area Network (LE-LAN) Devices
ANSI C63.10-2013	American National Standard for Testing Unlicensed Wireless Devices

Note(s):

All test items were verified and recorded according to the standards and without any addition/deviation/exclusion during the test.

TEST REPORT

Report No.: SHE20100017-02HE

Date: 2021-03-15

Page 5 of 53

2 Test Condition

2.1 Environmental conditions

Temperature (°C)	18-25
Humidity (%RH)	40-65
Barometric Pressure (mbar)	960-1060

2.2 Equipment List

Name of Equipment	Manufacturer	Model	Serial No.	Cal. Due Date
Spectrum Analyzer	Keysight	N9020A	MY59260184	2021-08-23
Spectrum Analyzer	Keysight	N9020B	MY59260184	2021-08-18
Spectrum Analyzer	Rohde & Schwarz	FSV40N	101450	2021-06-08
EMI Test Receiver	Rohde & Schwarz	ESPI3	100173	2021-06-08
EMI Test Receiver	Rohde & Schwarz	ESR 7	101911	2021-06-08
V-network	SCHWARZBECK	NSLK 8127	8127-902	2021-07-28
Broadband Antenna	SCHWARZBECK	VULB9163	9163-1037	2021-06-08
Horn Antenna-18G	SCHWARZBECK	BBHA9120D	9120D-1775	2021-07-28
Loop Antenna	SCHWARZBECK	FMZB 1513	N/A	2021-11-22
Horn Antenna-40G	YINGLIAN	LB-180400-KF	N/A	2021-07-26
EMC chamber 9*6*6 (L*W*H)	CHANGNING	966	N/A	2023-06-08
Shielded Enclosure 8*5*4 (L*W*H)	CHANGNING	854	N/A	2021-06-08
Test Software	BL	BL410_E	N/A	N/A
Test Software	BL	BL410_R	N/A	N/A

2.3 Measurement Uncertainty

Parameter	Frequency	Uncertainty
Antenna Port Conducted Emission	< 1GHz	± 1.5 dB
	> 1GHz	± 1.5 dB
Radiated Emission	30 MHz – 1 GHz	± 3 dB
	> 1GHz	± 3 dB

TEST REPORT

Report No.: SHE20100017-02HE

Date: 2021-03-15

Page 6 of 53

3 Test Set-up and Operation Modes

3.1 Details of Test Mode

Using test software was control EUT work in continuous transmitter and receiver mode. Select test channel as below:

Channel	Frequency
The lowest channel(CH0)	2402MHz
The middle channel(CH39)	2441MHz
The Highest channel(CH78)	2480MHz

The basic operation modes are:

- A. On
 - 1. BR/EDR mode
 - a. Transmitting
 - i. Low Channel
 - ii. Middle Channel
 - iii. High Channel
 - iv. Hopping mode
 - b. Receiving
 - 2. Normal working with Bluetooth on
- B. Standby
- C. Off

3.2 Special Accessories and Auxiliary Equipment

Description	Manufacturer	Model No.	Serial No.
Laptop	Lenovo	TP00083A	N/A

3.3 Support Software

Description	Manufacturer	Software Name
Software	Qualcomm	QRCT

TEST REPORT

Report No.: SHE20100017-02HE

Date: 2021-03-15

Page 7 of 53

3.4 Test Setup Diagram

Diagram of Measurement Configuration for Radiation Test

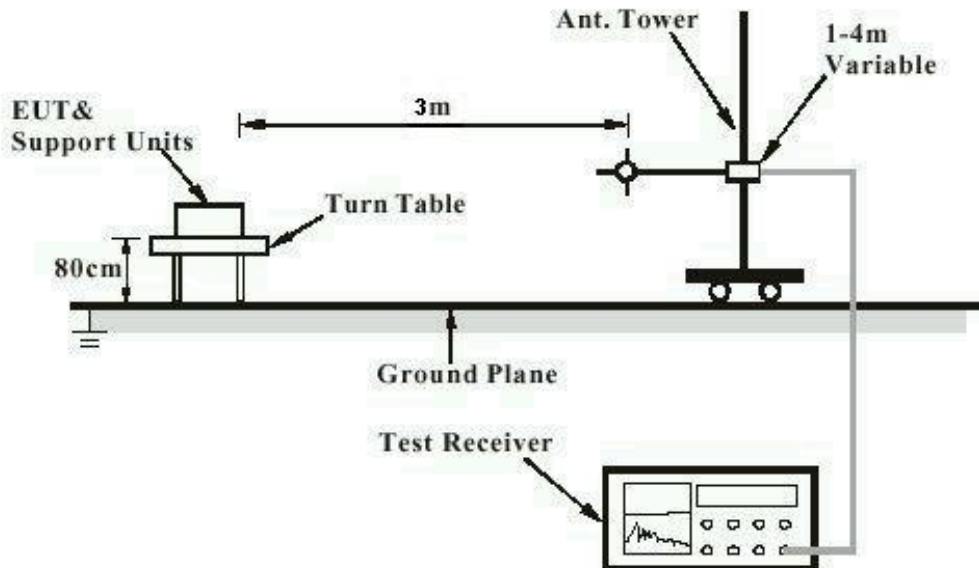

Note: Measurements above 1GHz are done with a table height of 1.5m. In addition, there is RF absorbing material on the floor of the test site for above 1GHz measurement.

Diagram of Measurement Equipment Configuration for Conduction Measurement

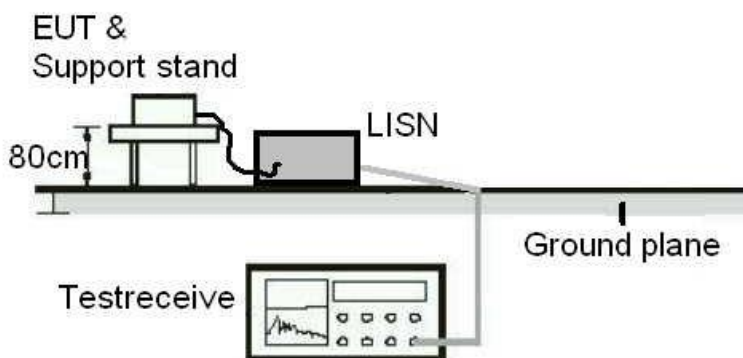

TEST REPORT

Report No.: SHE20100017-02HE

Date: 2021-03-15

Page 8 of 53

Diagram of Measurement Equipment Configuration for Transmitter Measurement

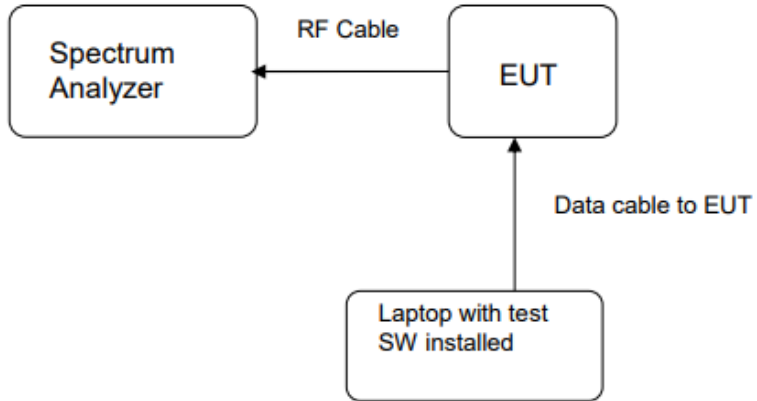

TEST REPORT

Report No.: SHE20100017-02HE

Date: 2021-03-15

Page 9 of 53

4 Test Results

4.1 Transmitter Requirement & Test Suites

4.1.1 Antenna Requirement

RESULT:

PASS

Test standard : FCC Part 15.247(b)(4), Part 15.203
RSS-247 5.4(6)

Requirement : The use of approved antennas only with directional gains that do not exceed 6dBi

According to the manufacturer declaration, the EUT has an antenna with a directional gain of 3.14dBi. The antenna is an internal antenna with no possibility of replacement with a non-approved antenna by the end-user.

Therefore, the EUT is considered to comply with this provision.

TEST REPORT

Report No.: SHE20100017-02HE

Date: 2021-03-15

Page 10 of 53

4.1.2 Maximum Conducted Output Power and E.I.R.P

RESULT:

PASS

Test standard : FCC Part 15.247(b)(1)
 RSS-247 5.4(2)
 Requirement : ANSI C63.10-2013
 Kind of test site : Shielded room

Test setup

Test Channel : Low/Middle/High
 Operation Mode : A.1.a
 Ambient temperature : 23°C
 Relative humidity : 52%

Table 1: Maximum Conducted Output Power

Test Mode	Test Channel (MHz)	Measured Peak Power		Limit (W)
		(dBm)	(mW)	
GFSK	2402	11.62	14.52	< 1
	2441	11.90	15.49	
	2480	11.34	13.61	
$\pi/4$ -DQPSK	2402	11.55	14.29	< 0.125
	2441	11.77	15.03	
	2480	11.21	13.21	
8-DPSK	2402	11.89	15.45	< 0.125
	2441	12.20	16.60	
	2480	11.68	14.72	

Table 2: E.I.R.P

Test Mode	Test Channel (MHz)	E.I.R.P		Limit (W)
		(dBm)	(mW)	
GFSK	2402	14.76	29.92	< 4
	2441	15.04	31.92	
	2480	14.48	28.05	
$\pi/4$ -DQPSK	2402	14.69	29.44	
	2441	14.91	30.97	
	2480	14.35	27.23	
8-DPSK	2402	15.03	31.84	
	2441	15.34	34.20	
	2480	14.82	30.34	

Note: The antenna gain is 3.14dBi

TEST REPORT

Report No.: SHE20100017-02HE

Date: 2021-03-15

Page 11 of 53

Figure 1: Maximum Conducted Output Power, 2402MHz, GFSK

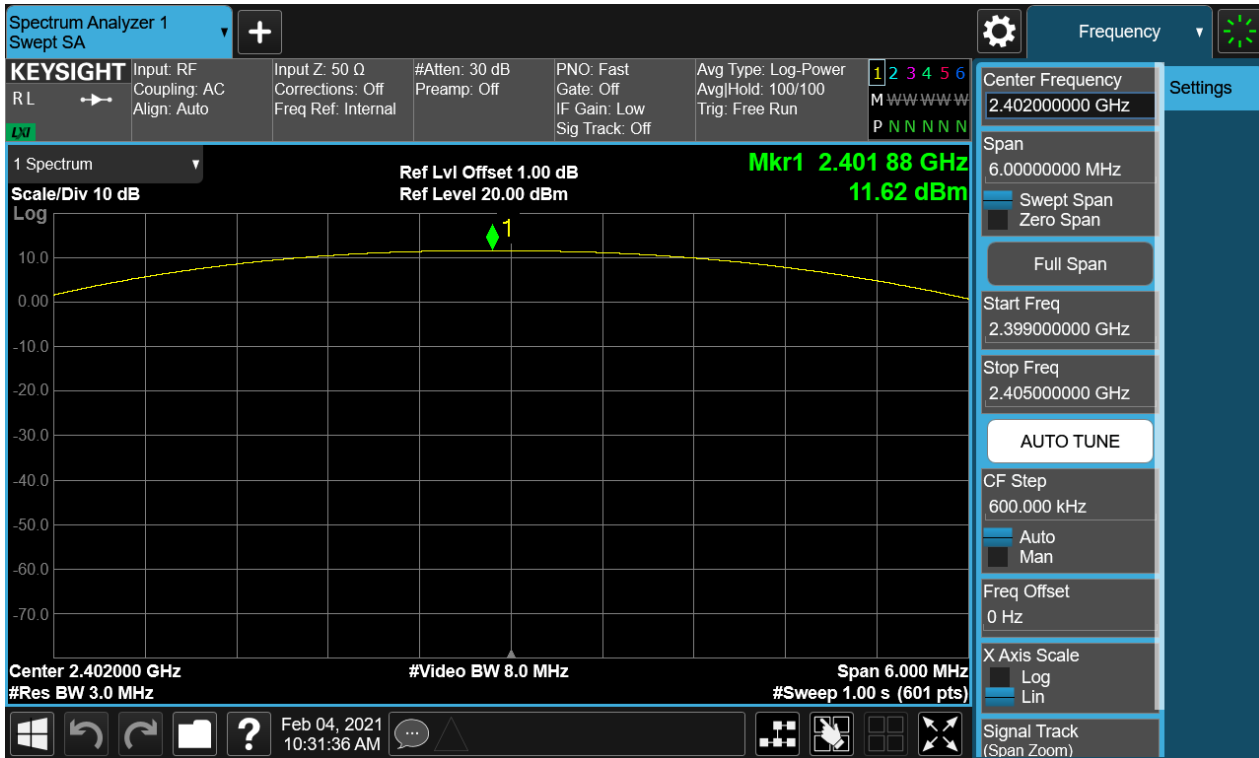
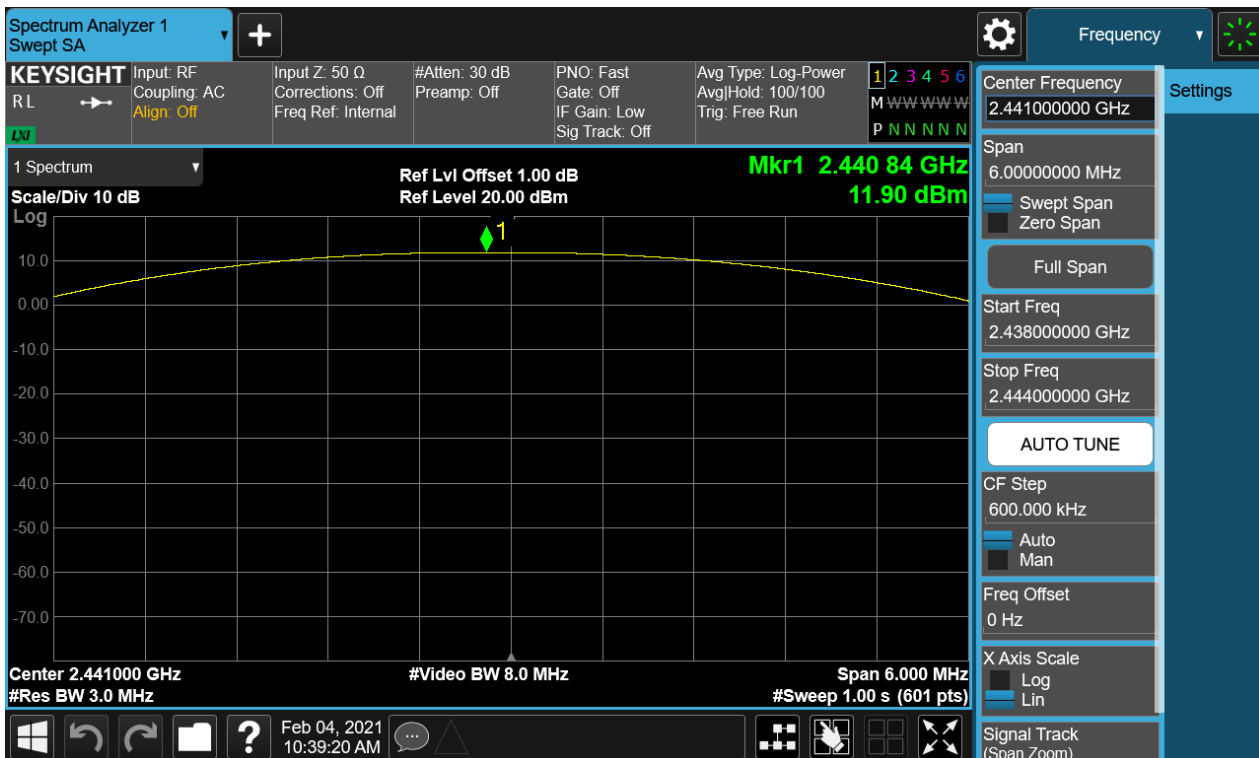

Figure 2: Maximum Conducted Output Power, 2441MHz, GFSK



TEST REPORT

Report No.: SHE20100017-02HE

Date: 2021-03-15

Page 12 of 53

Figure 3: Maximum Conducted Output Power, 2480MHz, GFSK

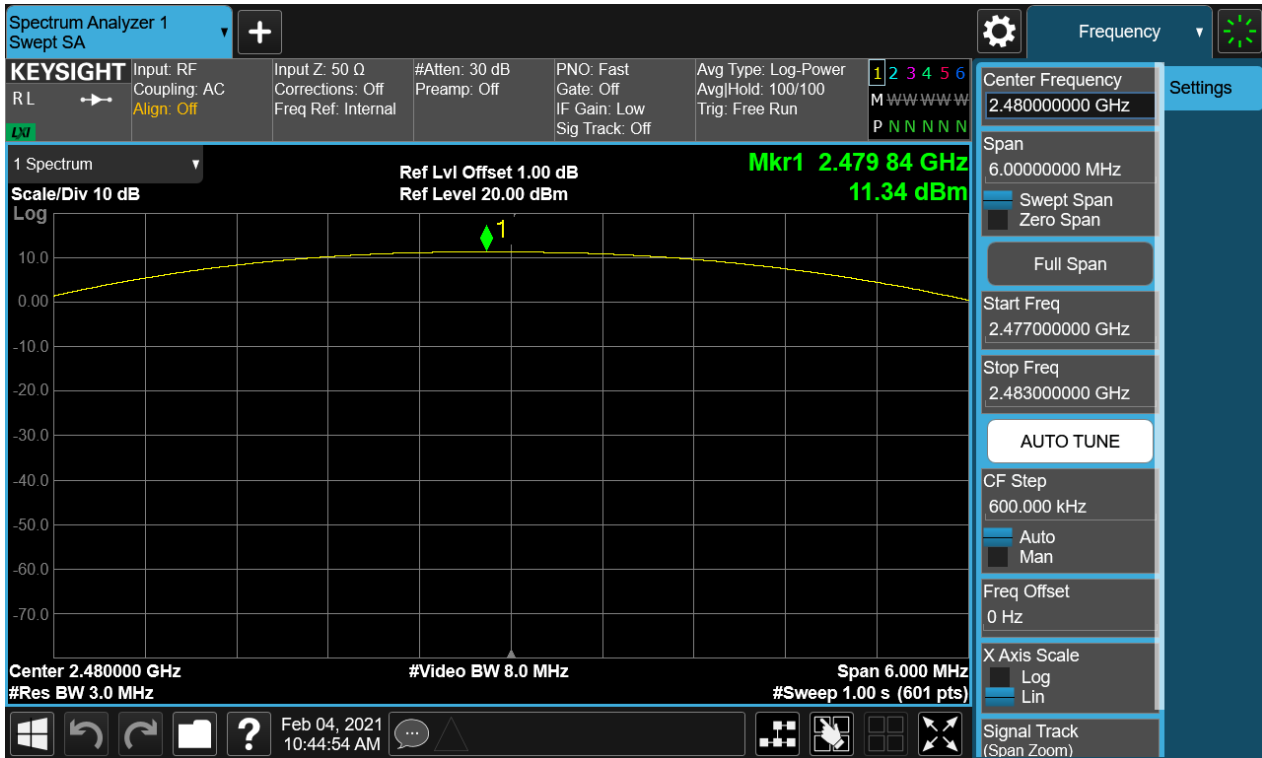
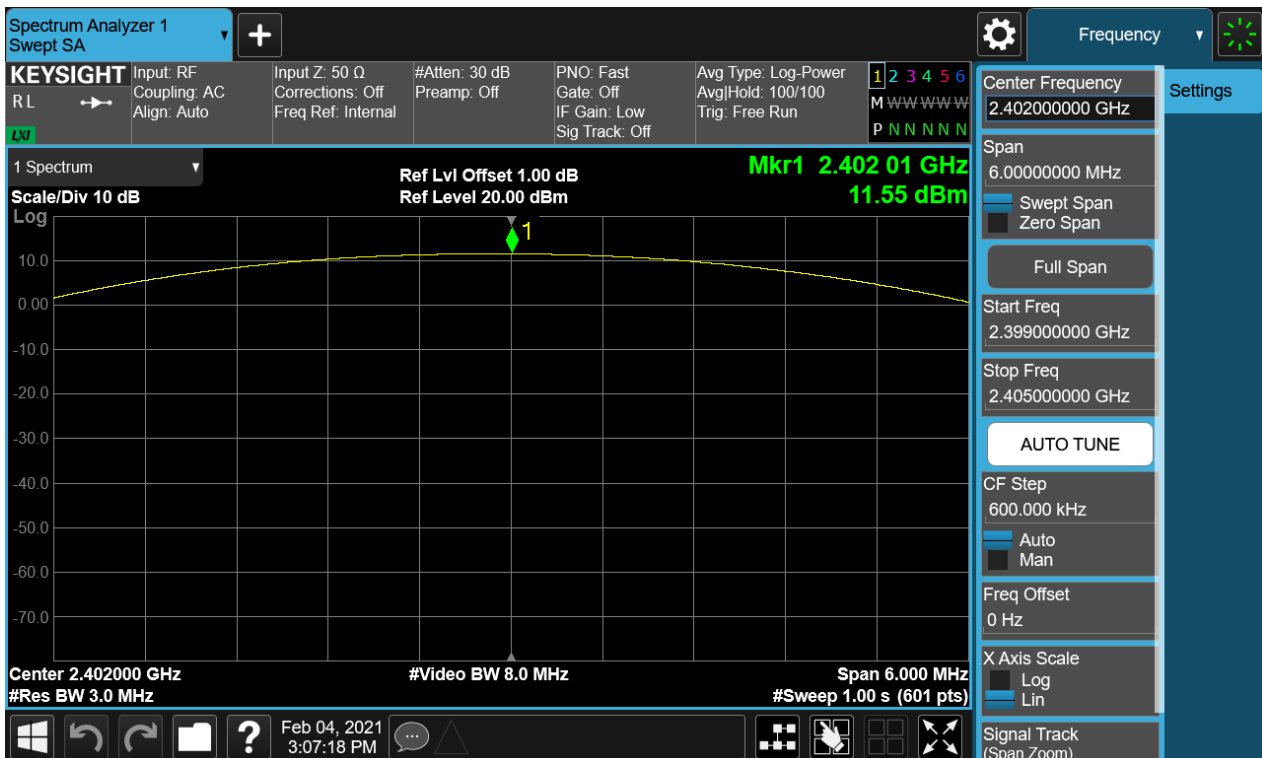

Figure 4: Maximum Conducted Output Power, 2402MHz, $\pi/4$ -DQPSK



TEST REPORT

Report No.: SHE20100017-02HE

Date: 2021-03-15

Page 13 of 53

Figure 5: Maximum Conducted Output Power, 2441MHz, $\pi/4$ -DQPSK

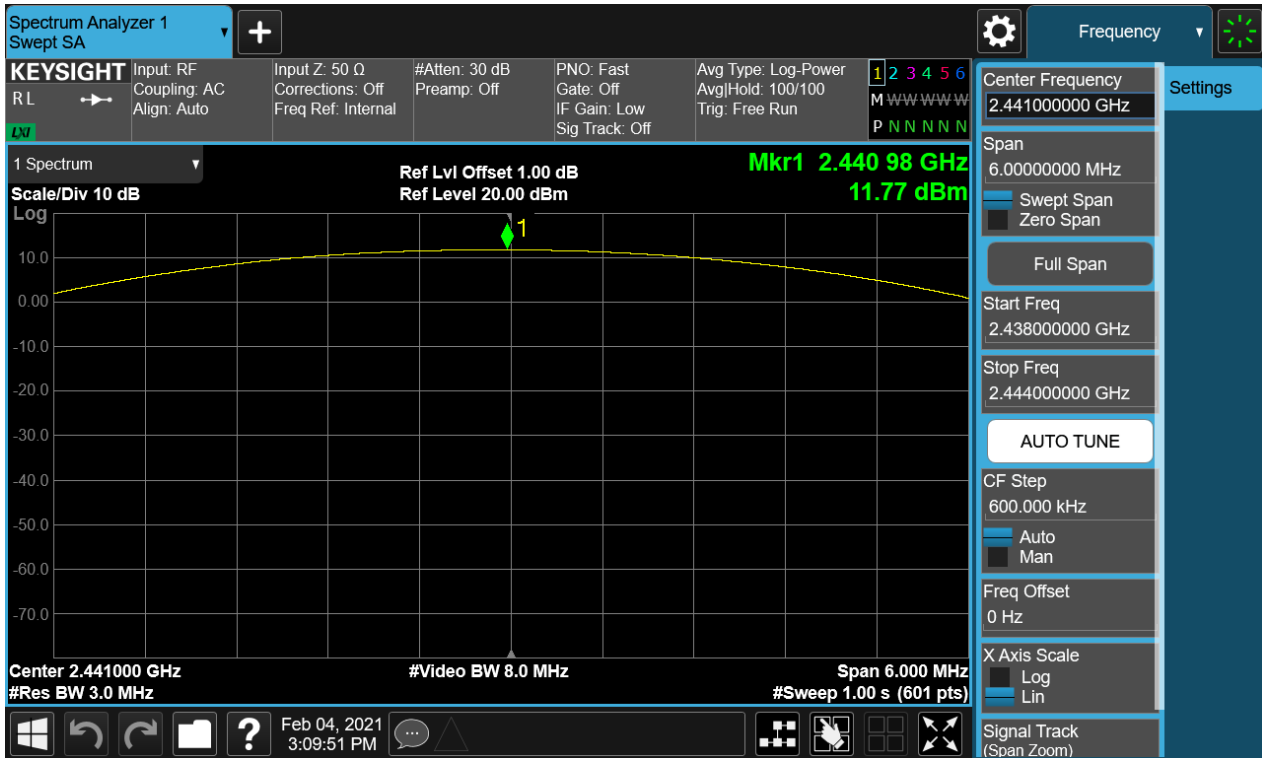

Figure 6: Maximum Conducted Output Power, 2480MHz, $\pi/4$ -DQPSK



TEST REPORT

Report No.: SHE20100017-02HE

Date: 2021-03-15

Page 14 of 53

Figure 7: Maximum Conducted Output Power, 2402MHz, 8-DPSK

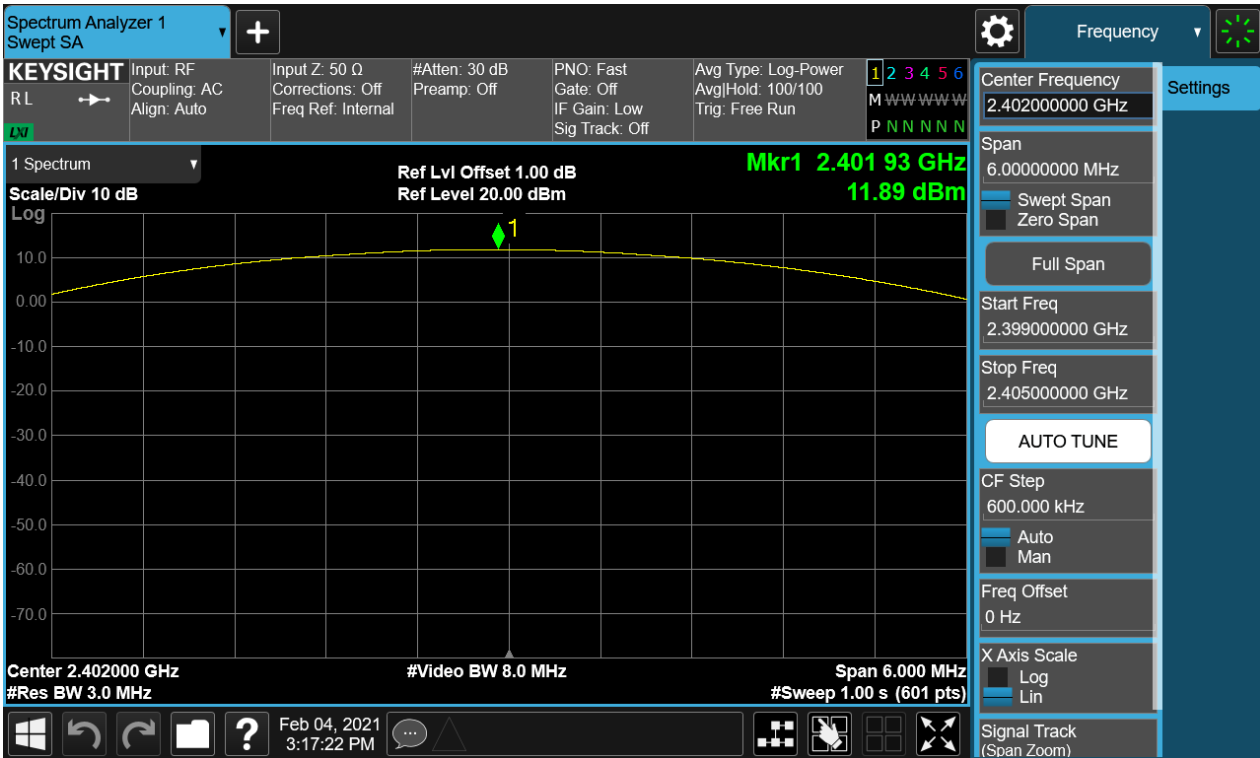
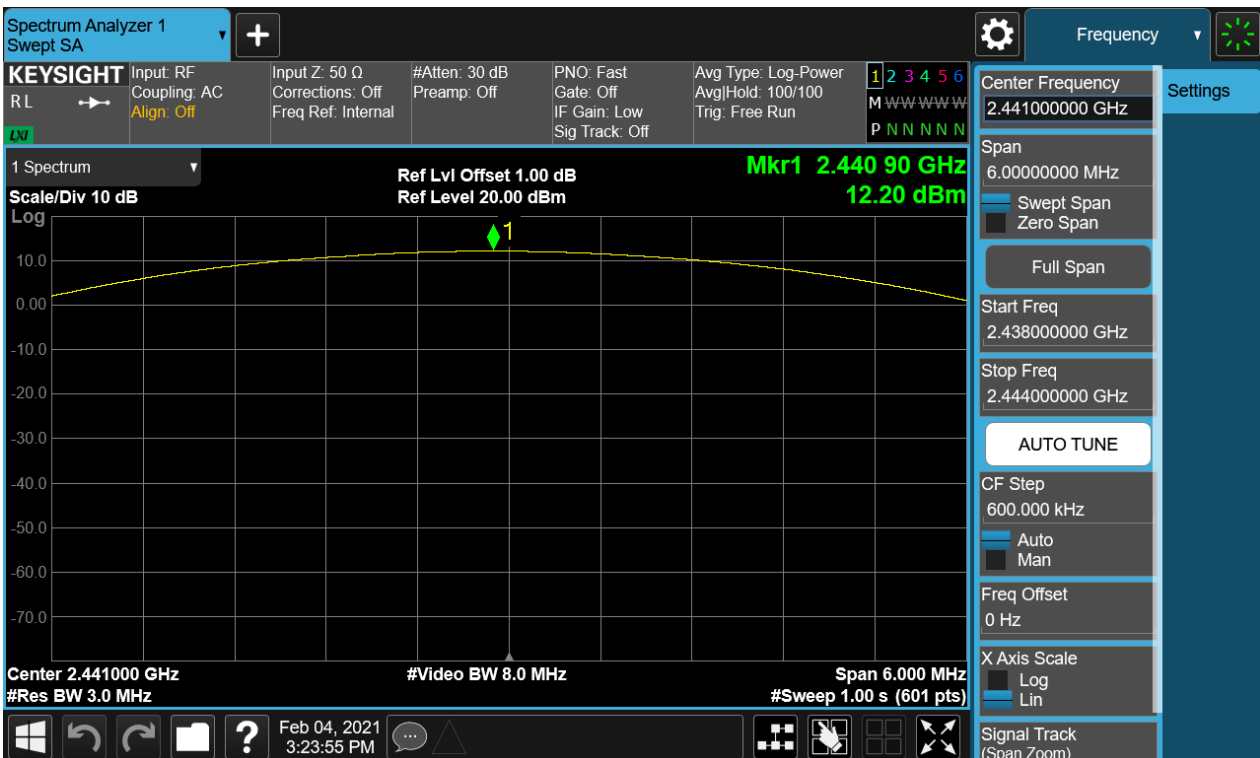

Figure 8: Maximum Conducted Output Power, 2441MHz, 8-DPSK



TEST REPORT

Report No.: SHE20100017-02HE

Date: 2021-03-15

Page 15 of 53

Figure 9: Maximum Conducted Output Power, 2480MHz, 8-DPSK

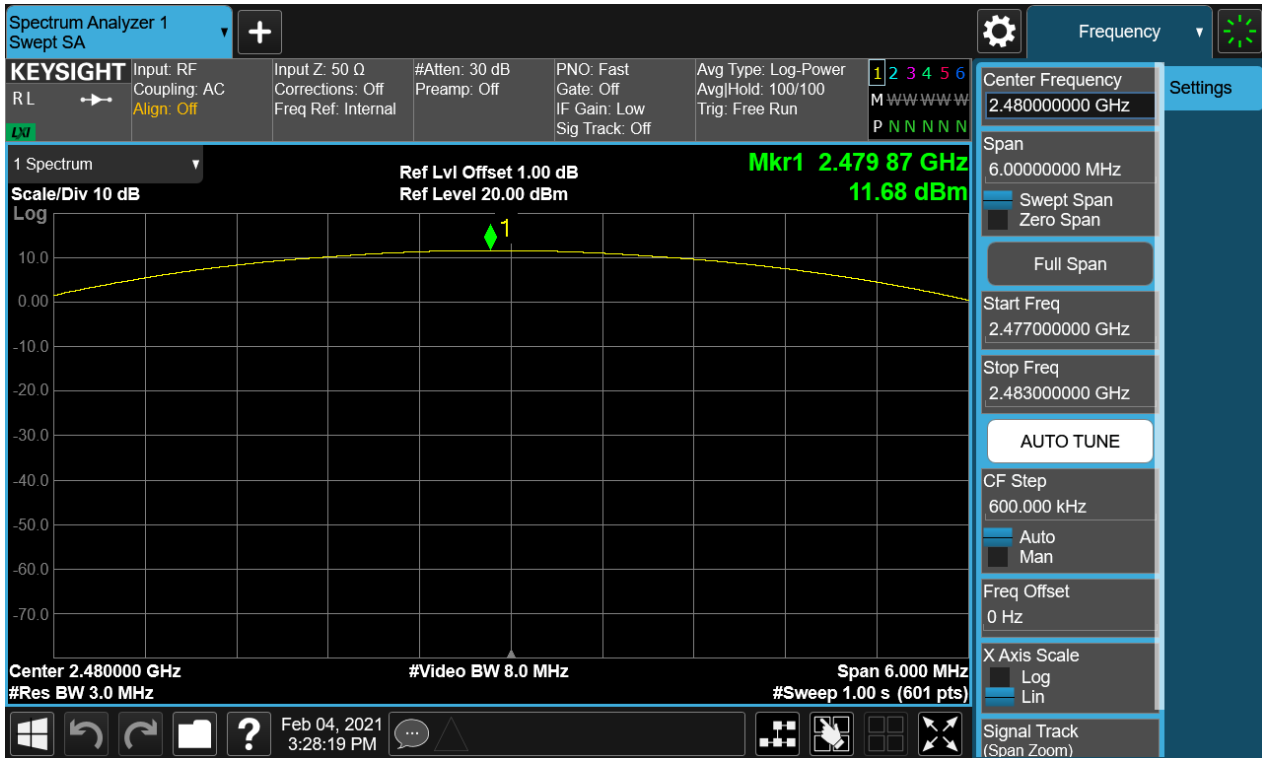

TEST REPORT

Report No.: SHE20100017-02HE

Date: 2021-03-15

Page 16 of 53

4.1.3 20dB Bandwidth and 99% Bandwidth

RESULT:

PASS

Test standard : FCC Part 15.247(a)(1)
RSS-247 5.1(1)
RSS-Gen 6.7
Requirement : ANSI C63.10-2013
Kind of test site : Shielded room

Test setup

Test Channel : Low/Middle/High
Operation Mode : A.1.a
Ambient temperature : 23°C
Relative humidity : 52%

Table 3: 20dB Bandwidth and 99% Bandwidth

Test Mode	Test Channel (MHz)	20dB Bandwidth (MHz)	99% Bandwidth (MHz)
GFSK	2402	0.994	0.908
	2441	1.003	0.908
	2480	0.993	0.906
8-DPSK	2402	1.293	1.178
	2441	1.293	1.178
	2480	1.293	1.177

TEST REPORT

Report No.: SHE20100017-02HE

Date: 2021-03-15

Page 17 of 53

Figure 10: 20dB Bandwidth and 99% Bandwidth, 2402MHz, GFSK

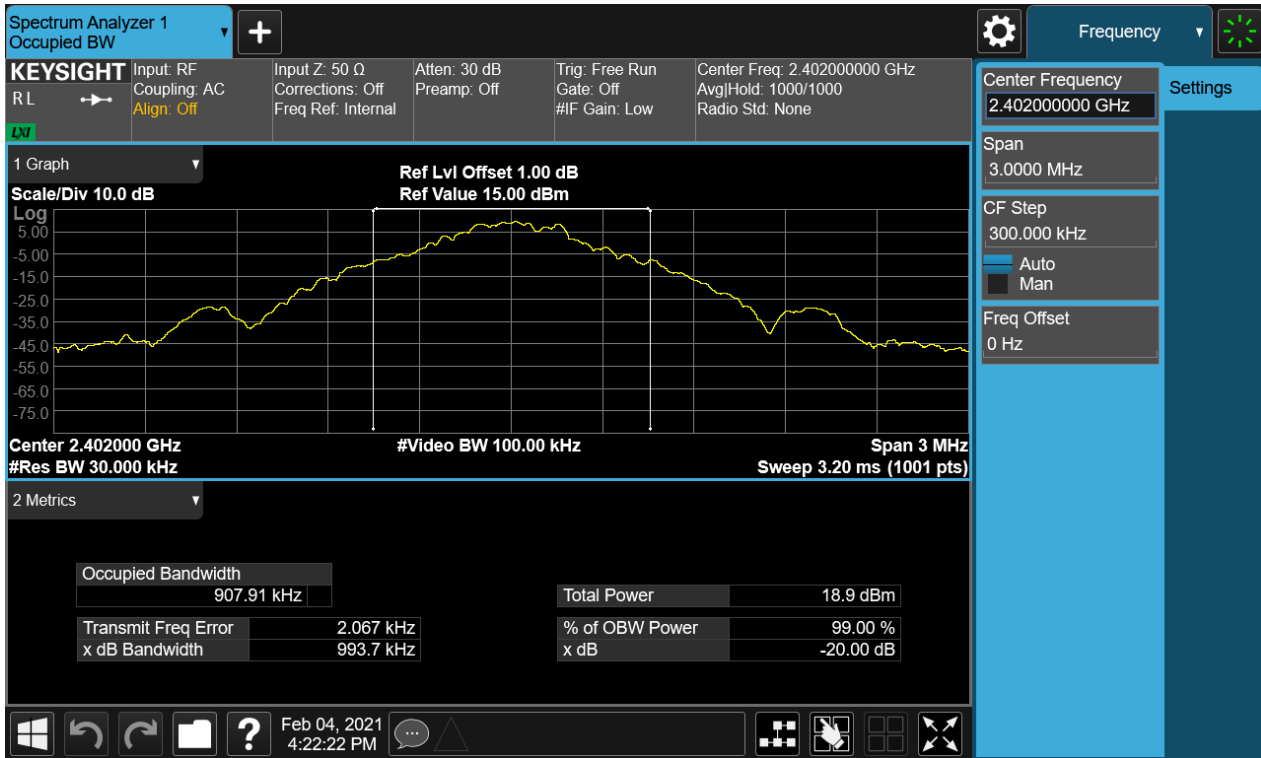

Figure 11: 20dB Bandwidth and 99% Bandwidth, 2441MHz, GFSK



TEST REPORT

Report No.: SHE20100017-02HE

Date: 2021-03-15

Page 18 of 53

Figure 12: 20dB Bandwidth and 99% Bandwidth, 2480MHz, GFSK



Figure 13: 20dB Bandwidth and 99% Bandwidth, 2402MHz, 8-DPSK

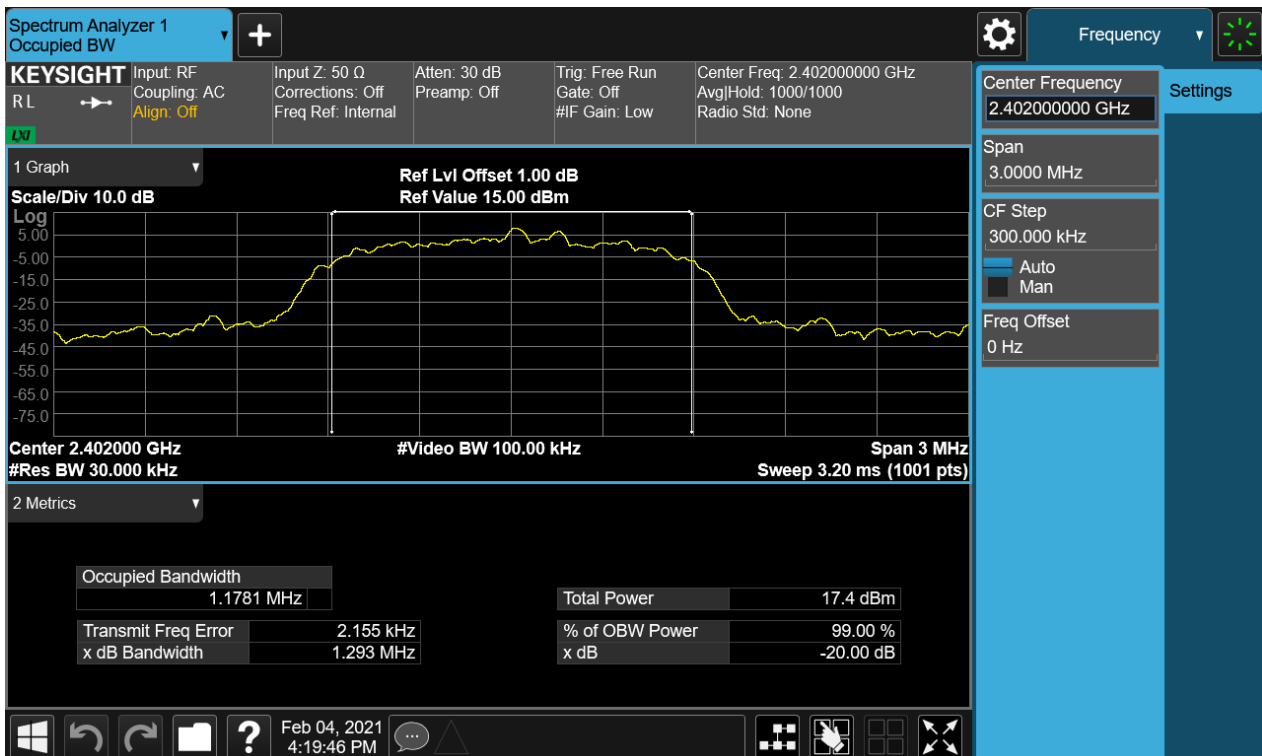

TEST REPORT

Report No.: SHE20100017-02HE

Date: 2021-03-15

Page 19 of 53

Figure 14: 20dB Bandwidth and 99% Bandwidth, 2441MHz, 8-DPSK

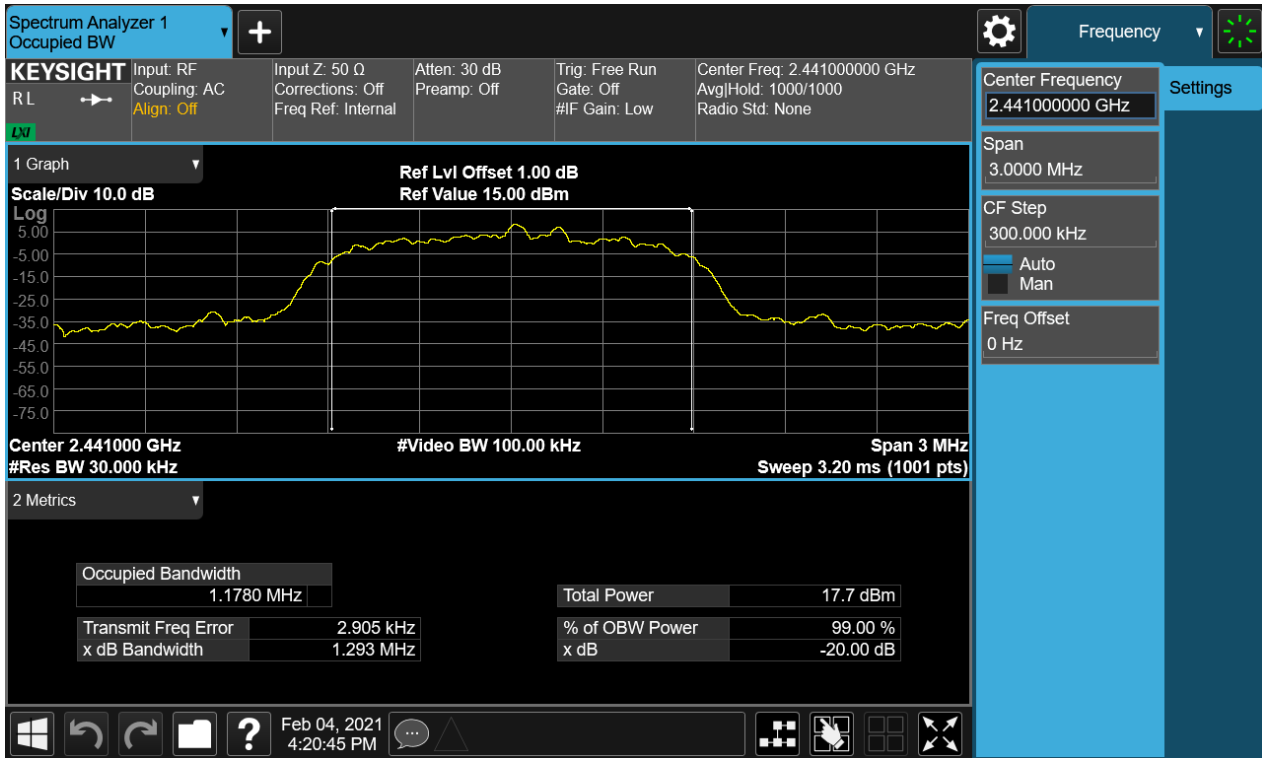
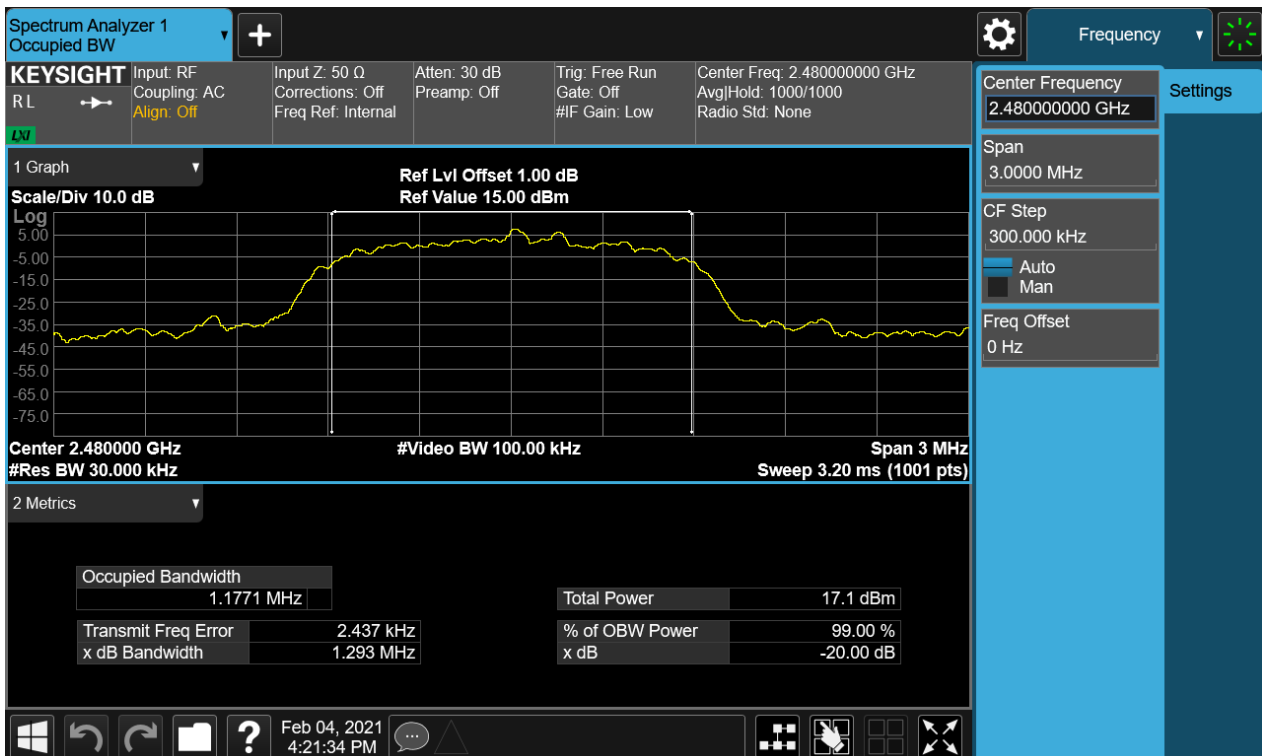

Figure 15: 20dB Bandwidth and 99% Bandwidth, 2480MHz, 8-DPSK



TEST REPORT

Report No.: SHE20100017-02HE

Date: 2021-03-15

Page 20 of 53

4.1.4 Conducted Spurious Emission & Authorized-band band-edge

RESULT:

PASS

Test standard : FCC Part 15.247(d)
RSS-247 5.5
Requirement : ANSI C63.10-2013
Kind of test site : Shielded room

Test setup

Test Channel : Low/Middle/High for spurious, Low/High for Band
Edge
Operation Mode : A.1.a
Ambient temperature : 23°C
Relative humidity : 52%

For details refer to following test plot.

TEST REPORT

Report No.: SHE20100017-02HE

Date: 2021-03-15

Page 21 of 53

Figure 16: Conducted Spurious Emission & Authorized-band band-edge, 2402MHz, GFSK Carrier Level



Band Edge

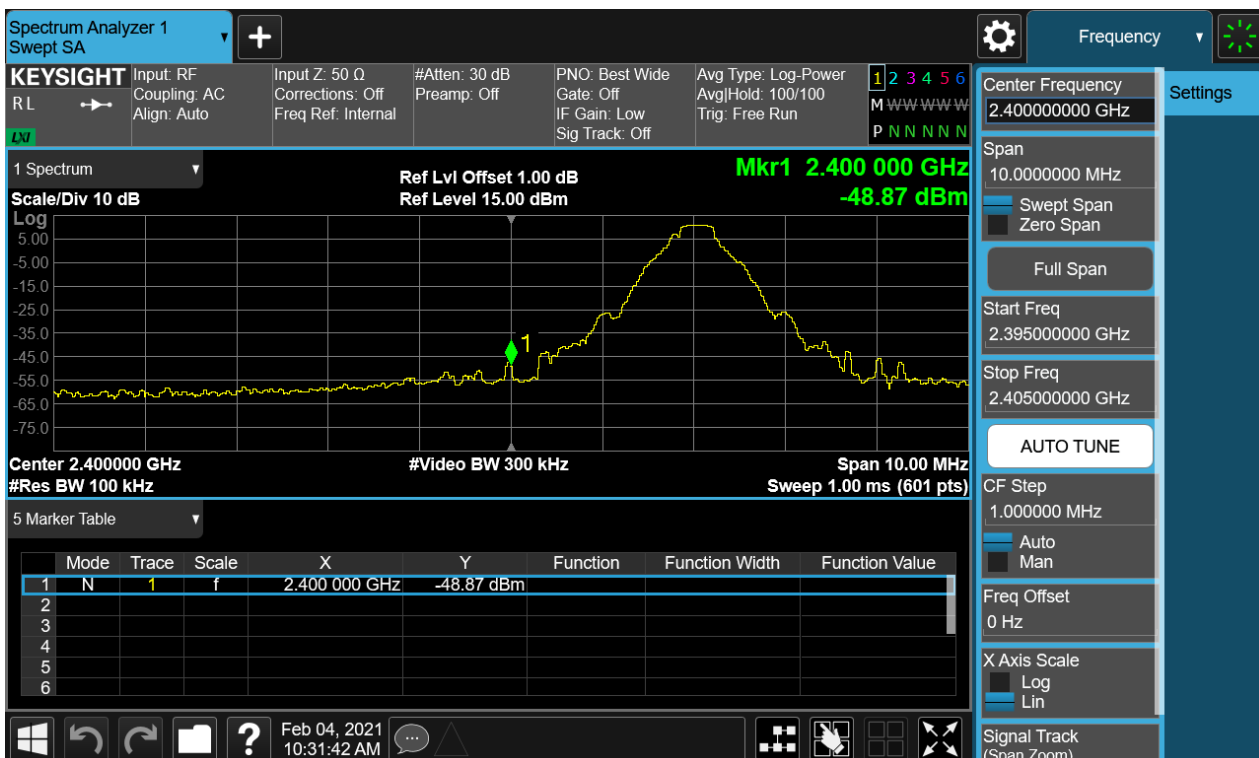

TEST REPORT

Report No.: SHE20100017-02HE

Date: 2021-03-15

Page 22 of 53

Conducted spurious emissions 30MHz-25GHz

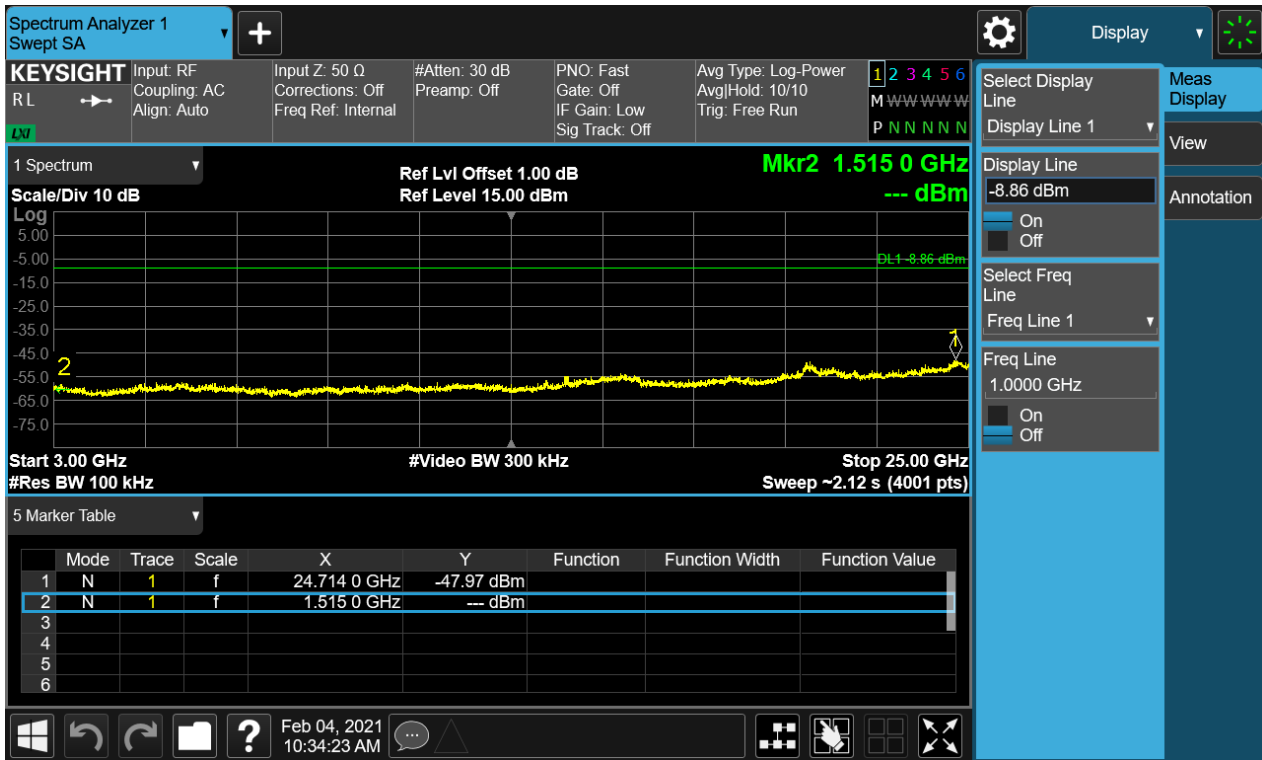
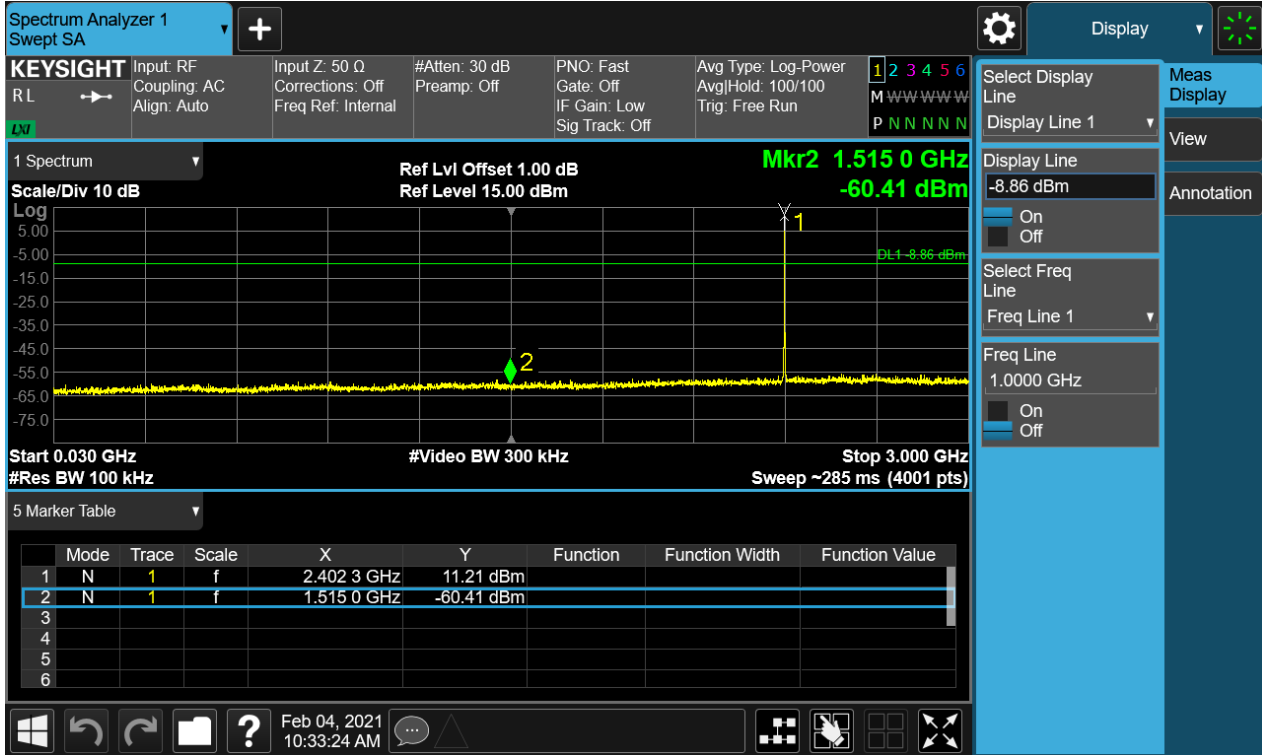

TEST REPORT

Report No.: SHE20100017-02HE

Date: 2021-03-15

Page 23 of 53

Figure 17: Conducted Spurious Emission & Authorized-band band-edge, 2441MHz, GFSK Carrier Level

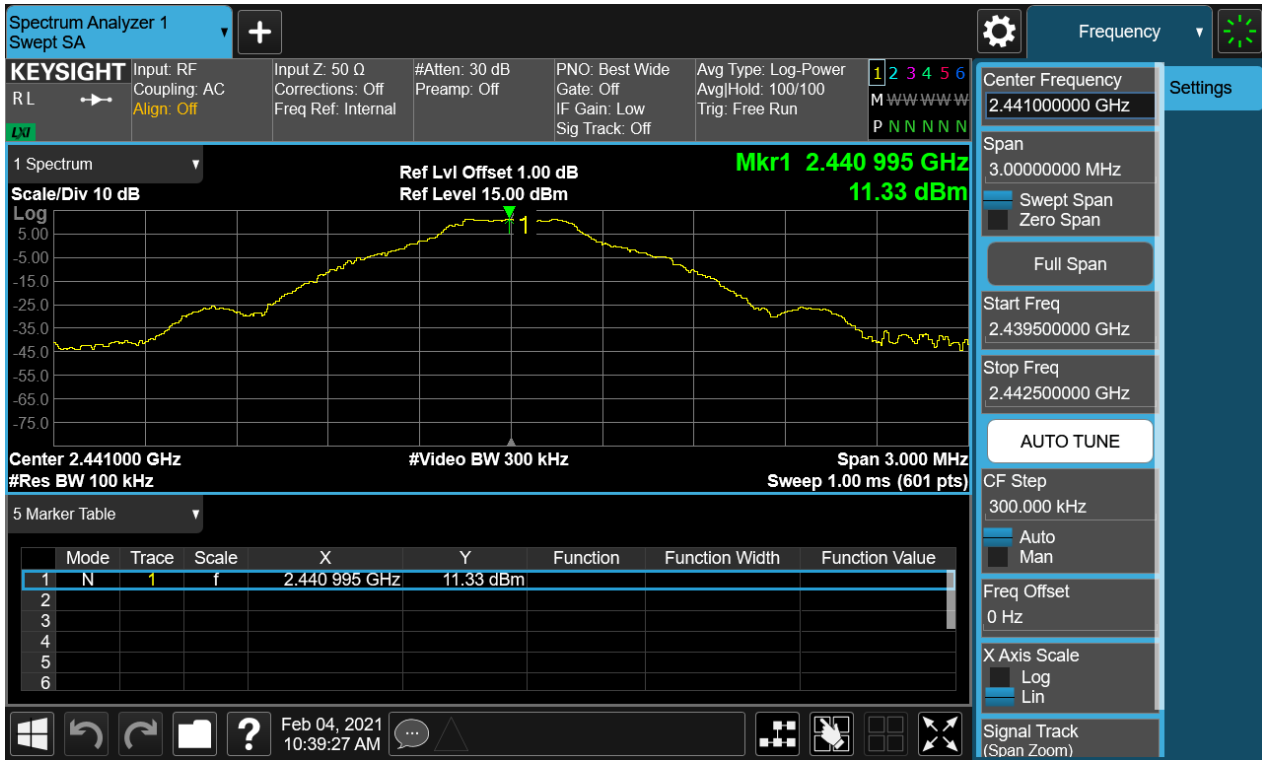

Conducted spurious emissions 30MHz-25GHz

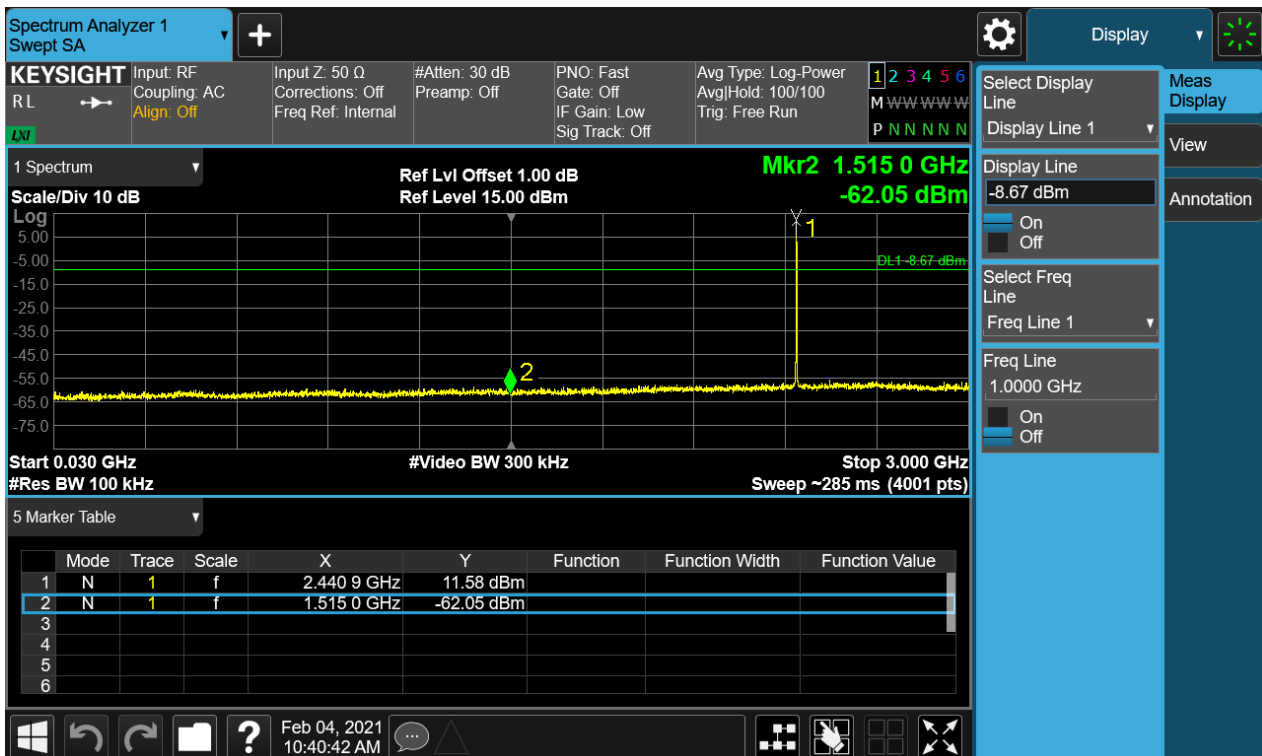

TEST REPORT

Report No.:

SHE20100017-02HE

Date:

2021-03-15

Page 24 of 53

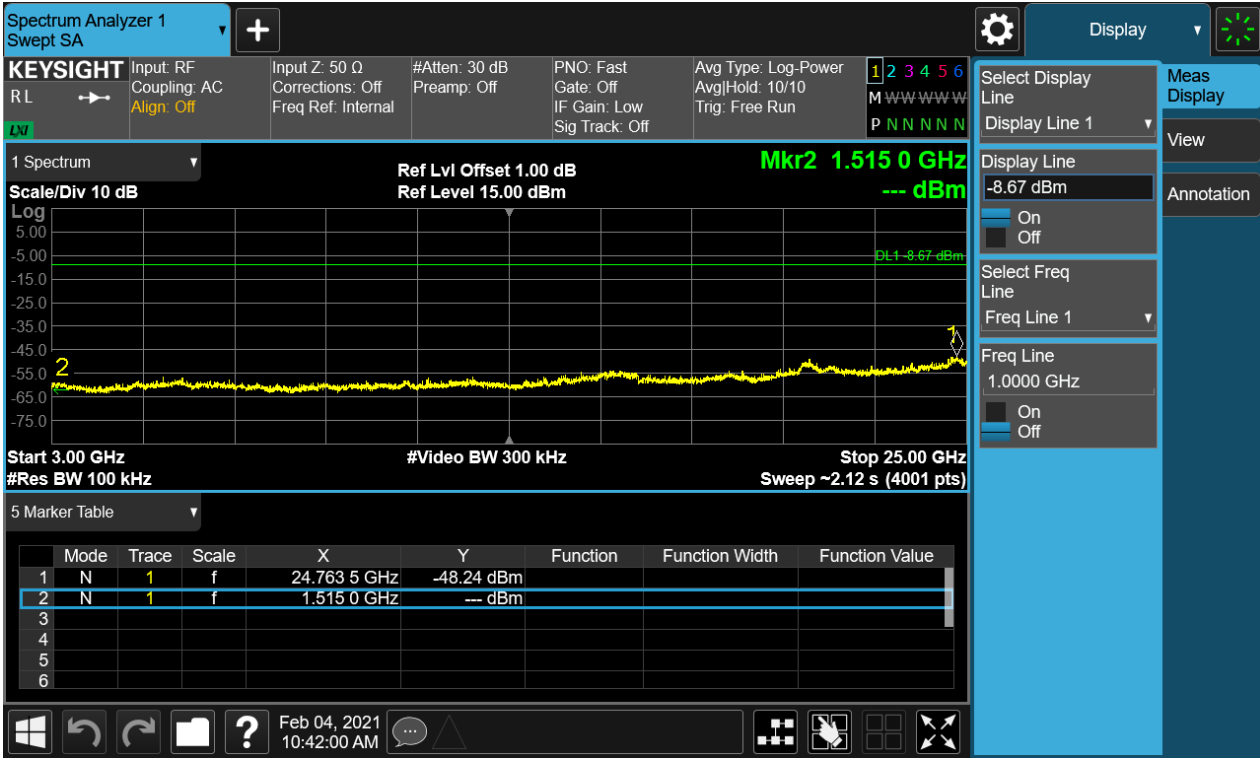

Figure 18: Conducted Spurious Emission & Authorized-band band-edge, 2480MHz, GFSK Carrier Level



TEST REPORT

Report No.: SHE20100017-02HE

Date: 2021-03-15

Page 25 of 53

Band Edge



Conducted spurious emissions 30MHz-25GHz

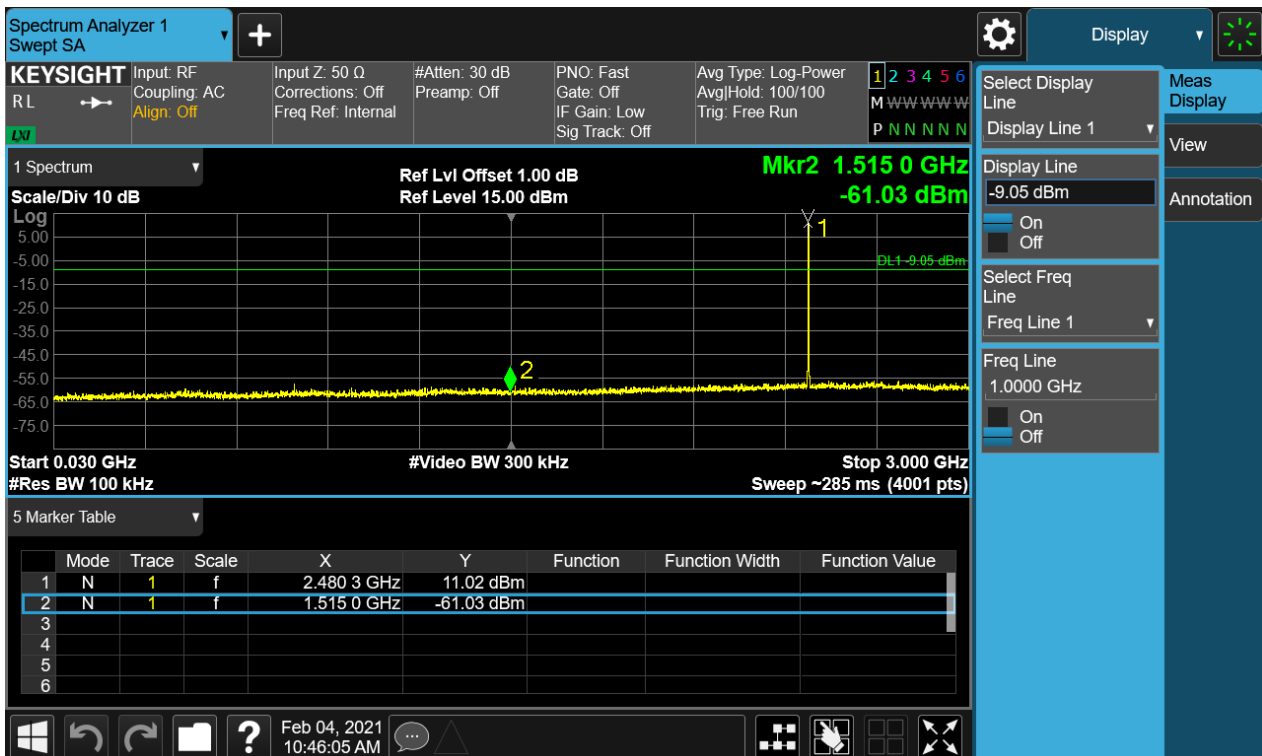

TEST REPORT

Report No.:

SHE20100017-02HE

Date:

2021-03-15

Page 26 of 53

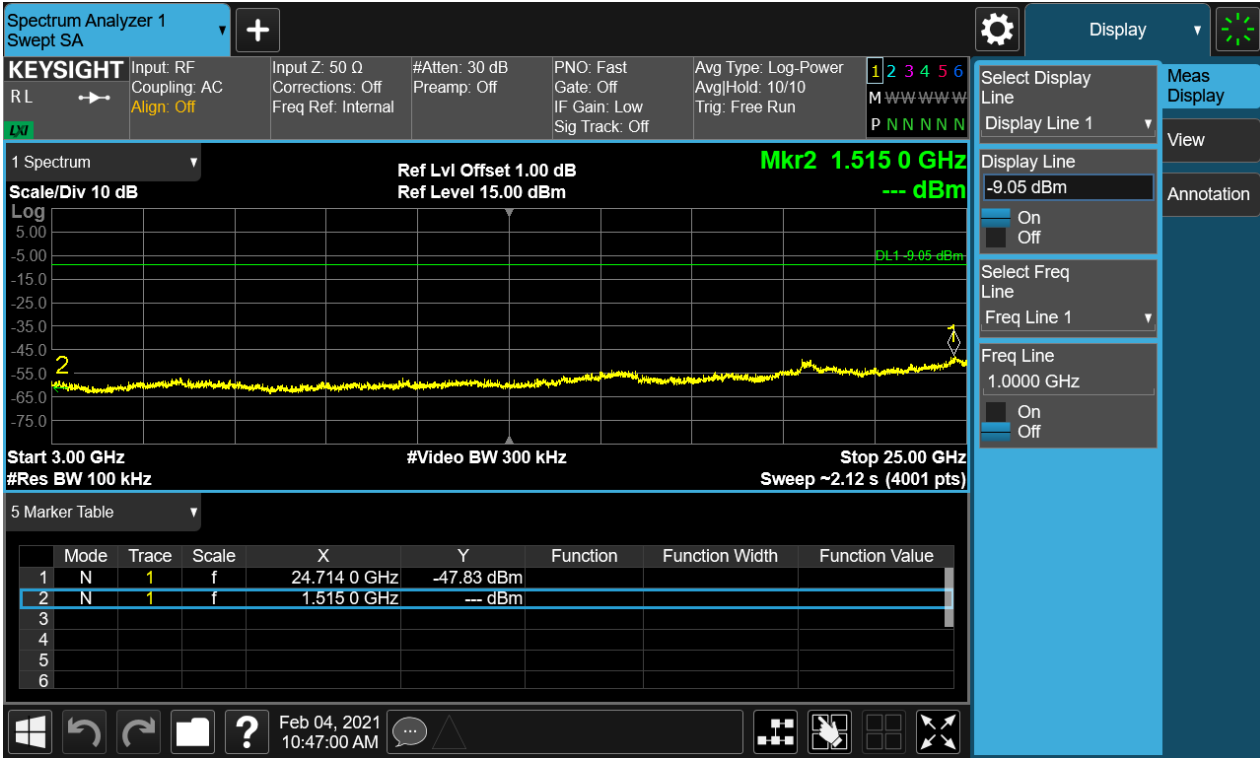
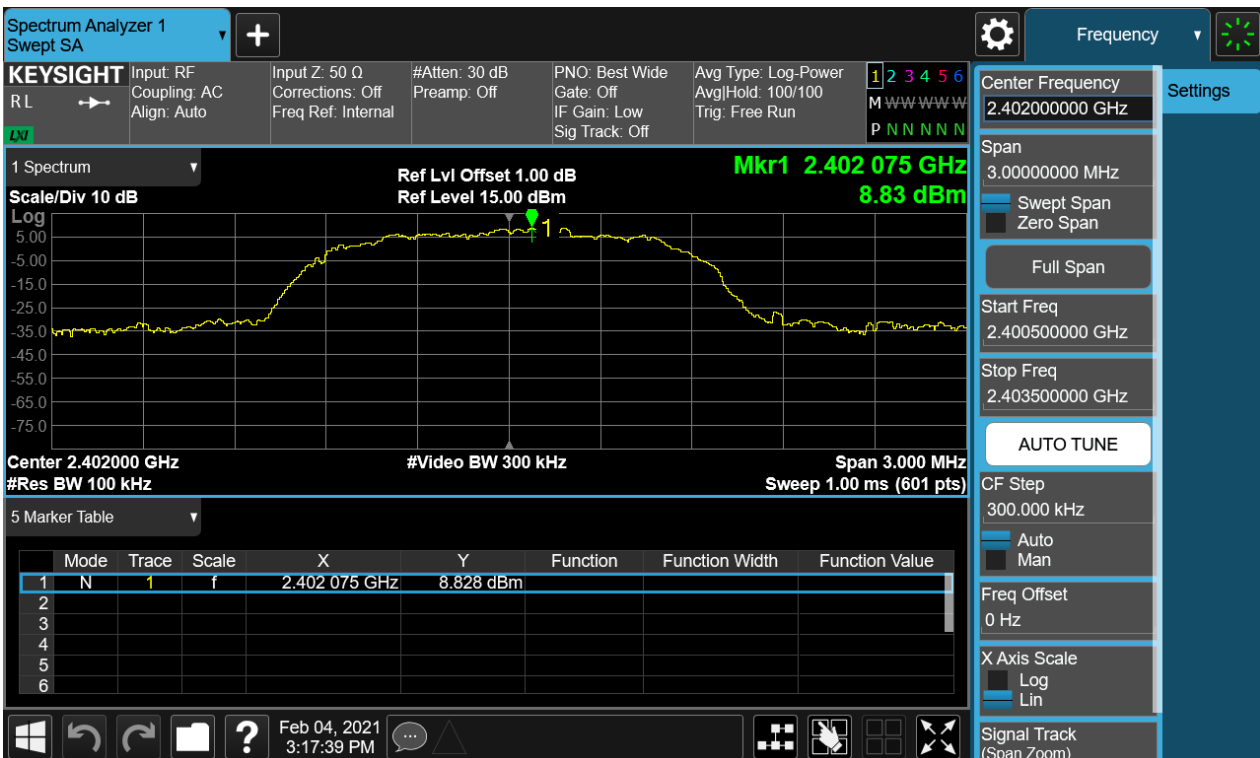

Figure 19: Conducted Spurious Emission & Authorized-band band-edge, 2402MHz, 8-DPSK Carrier Level



TEST REPORT

Report No.: SHE20100017-02HE

Date: 2021-03-15

Page 27 of 53

Band Edge



Conducted spurious emissions 30MHz-25GHz

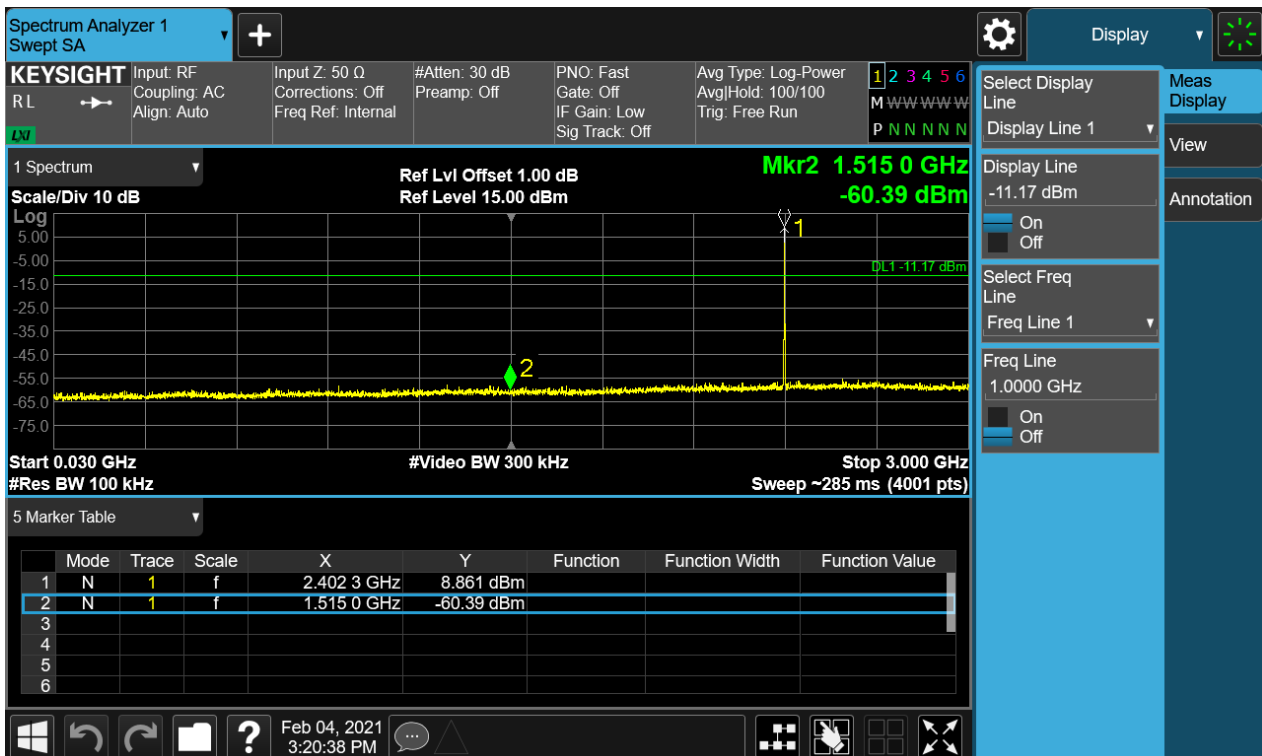

TEST REPORT

Report No.:

SHE20100017-02HE

Date:

2021-03-15

Page 28 of 53

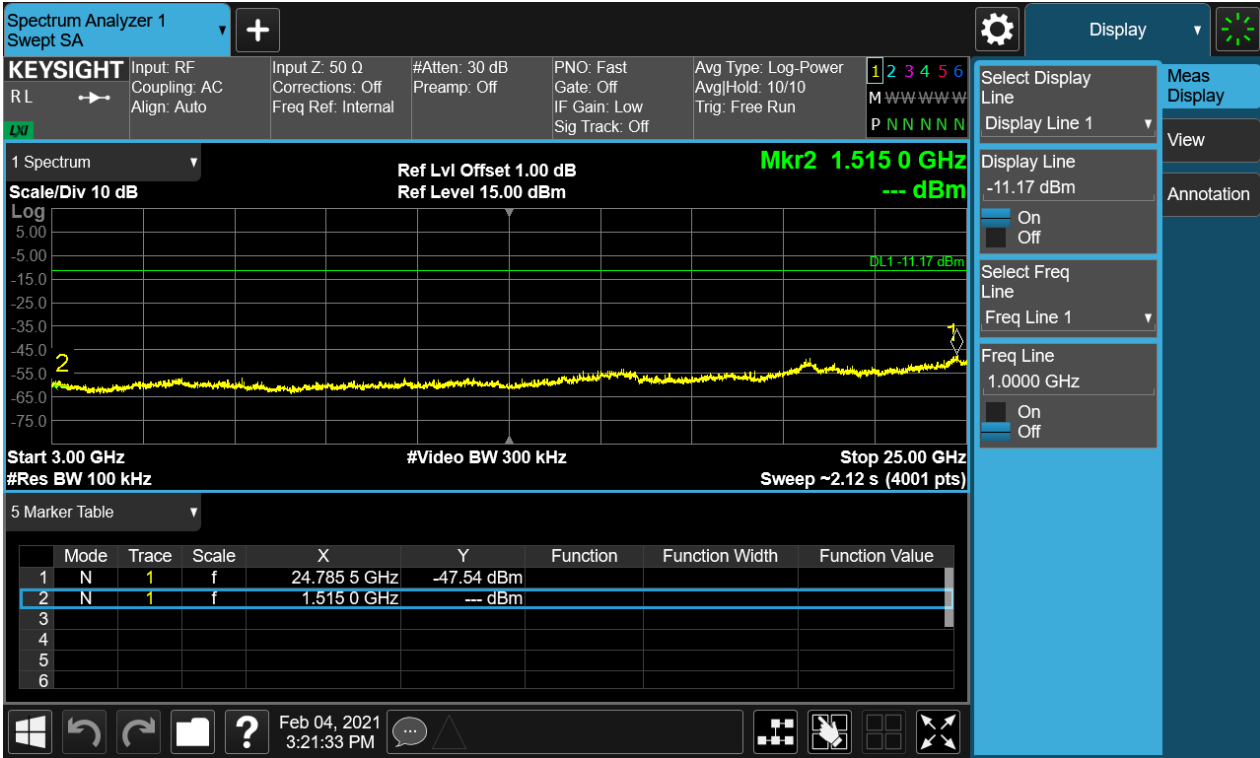

Figure 20: Conducted Spurious Emission & Authorized-band band-edge, 2441MHz, 8-DPSK Carrier Level



TEST REPORT

Report No.: SHE20100017-02HE

Date: 2021-03-15

Page 29 of 53

Conducted spurious emissions 30MHz-25GHz

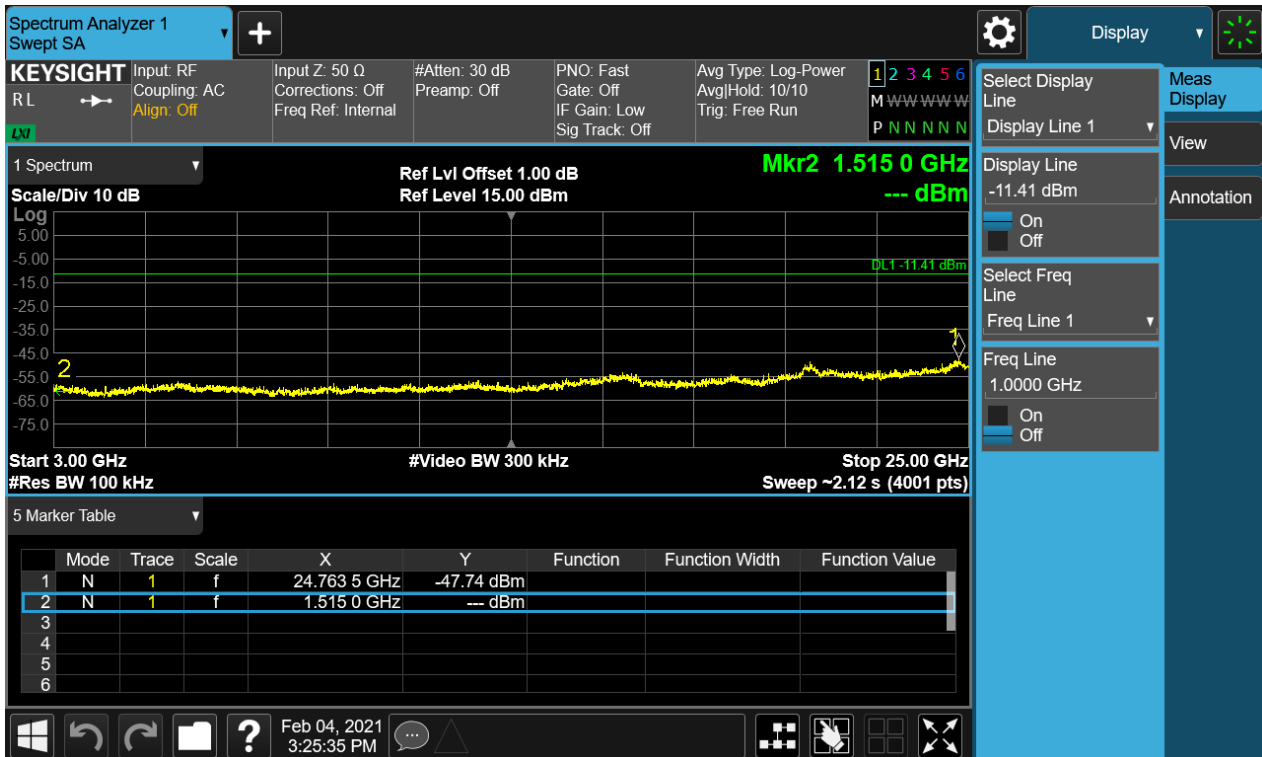
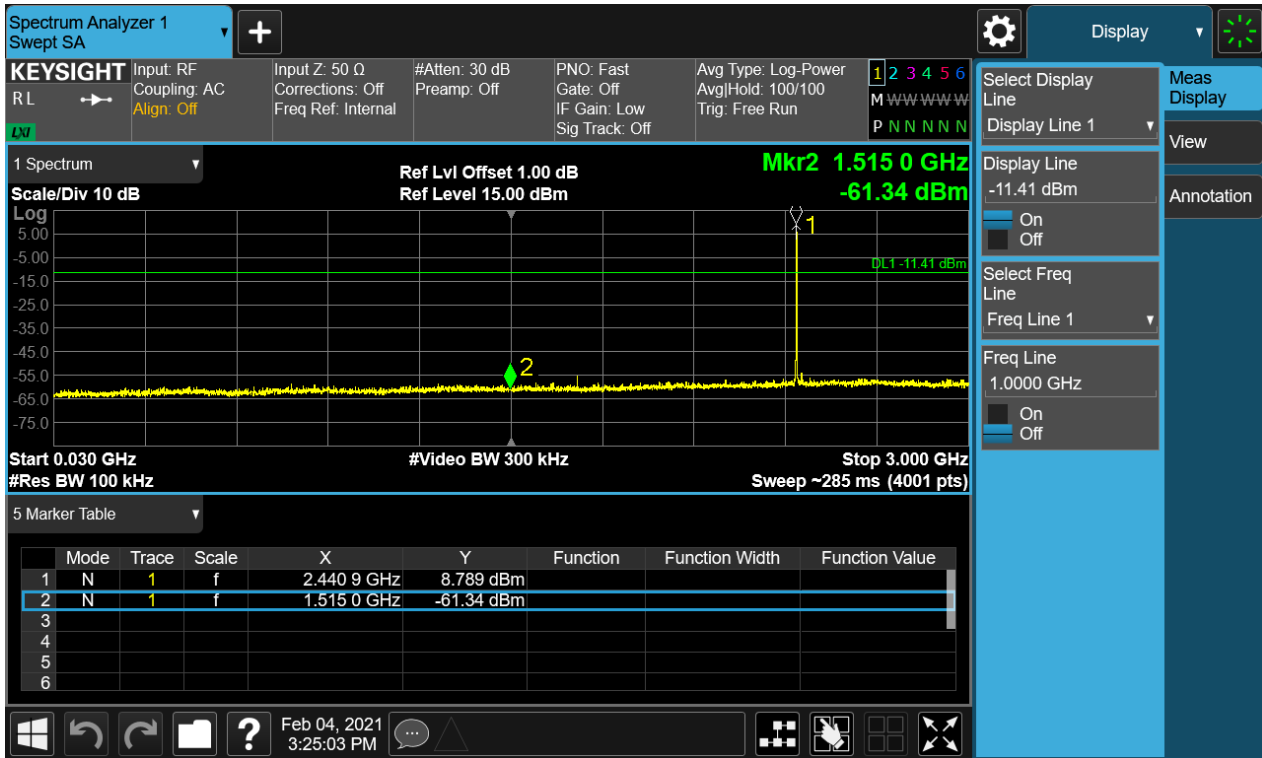

TEST REPORT

Report No.: SHE20100017-02HE

Date: 2021-03-15

Page 30 of 53

Figure 21: Conducted Spurious Emission & Authorized-band band-edge, 2480MHz, 8-DPSK Carrier Level

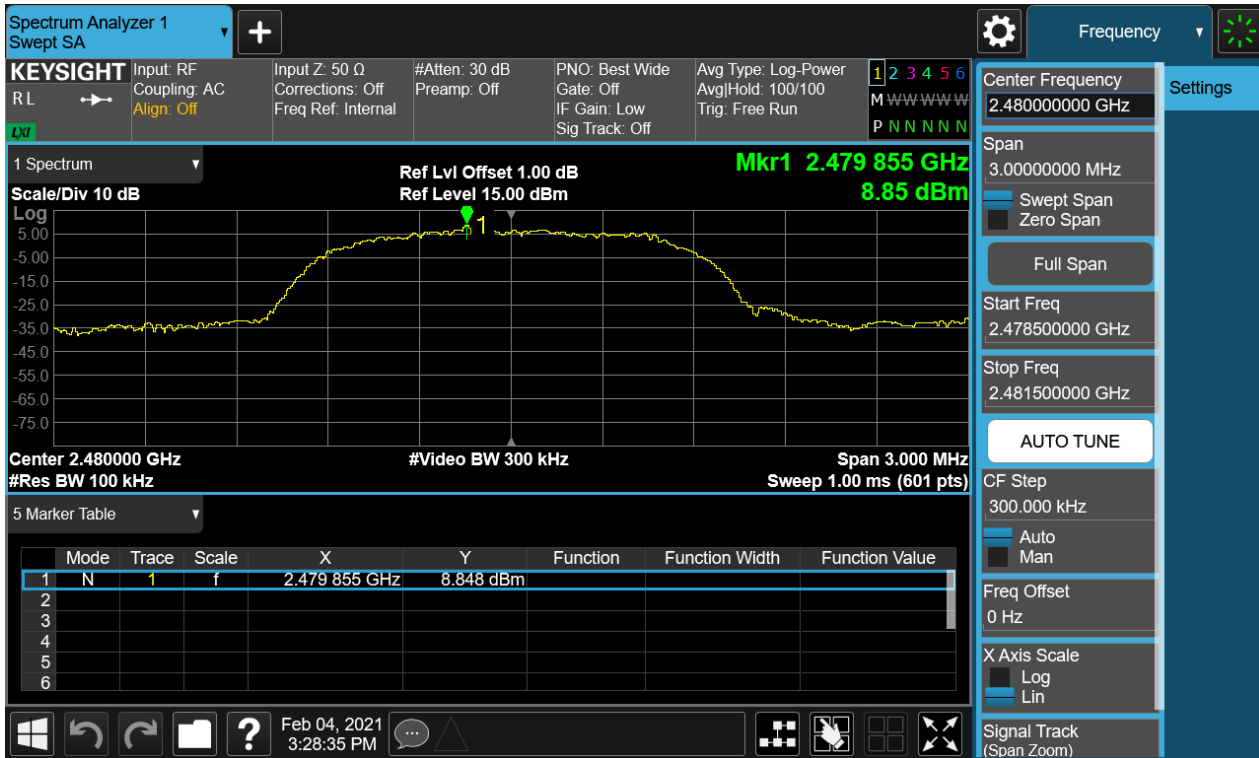

Band Edge

