

- | link
- | dr4-2.sch
- | dr4-3.sch
- | dr4-4.sch
- | dr4-5.sch
- | dr4-6.sch
- | dr4-7.sch
- | dr4-8.sch
- | dr4-9.sch
- | dr4-10.sch
- | dr4-11.sch
- | dr4-12.sch
- | dr4-13.sch
- | dr4-14.sch
- | dr4-15.sch
- | pcmcia_b.sch
- | pcmcia1.sch
- | pcmcia2.sch
- | pcmcia3.sch

| | | |
|--|--------------------------------------|---------------|
| TeLLUS TECHNOLOGY INC. 40990 Encyclopedia Circle Fremont, CA 94538 | | |
| Drawn By: K. Dunnegan | | |
| Title P1005 RF DIPLEXER / DIVERSITY SWITCH | | |
| Size B | Document Number DR4-1.SCH (30KHz) | Rev |
| Date: | Wednesday, May 19, 1999 | Sheet 1 of 19 |

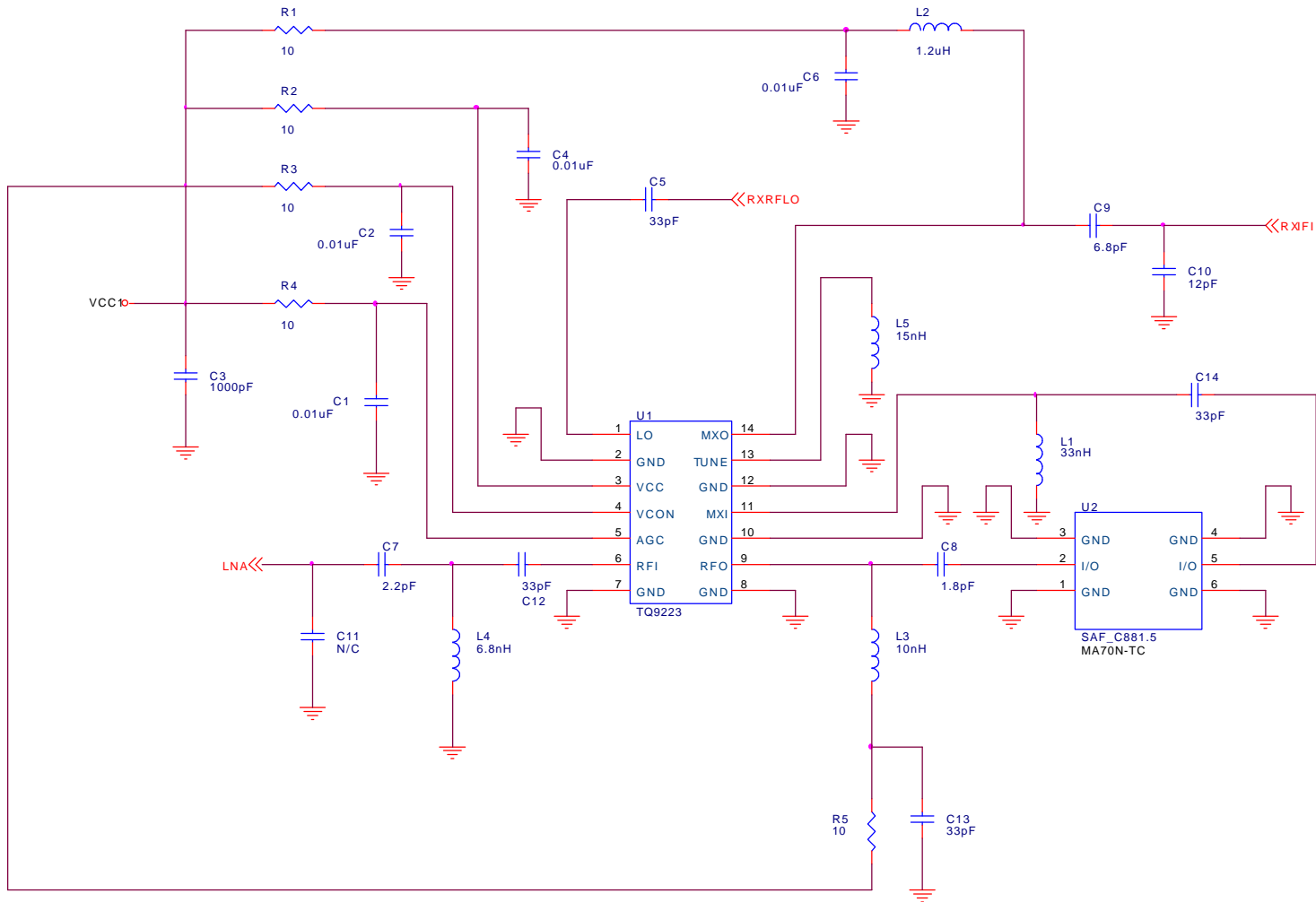

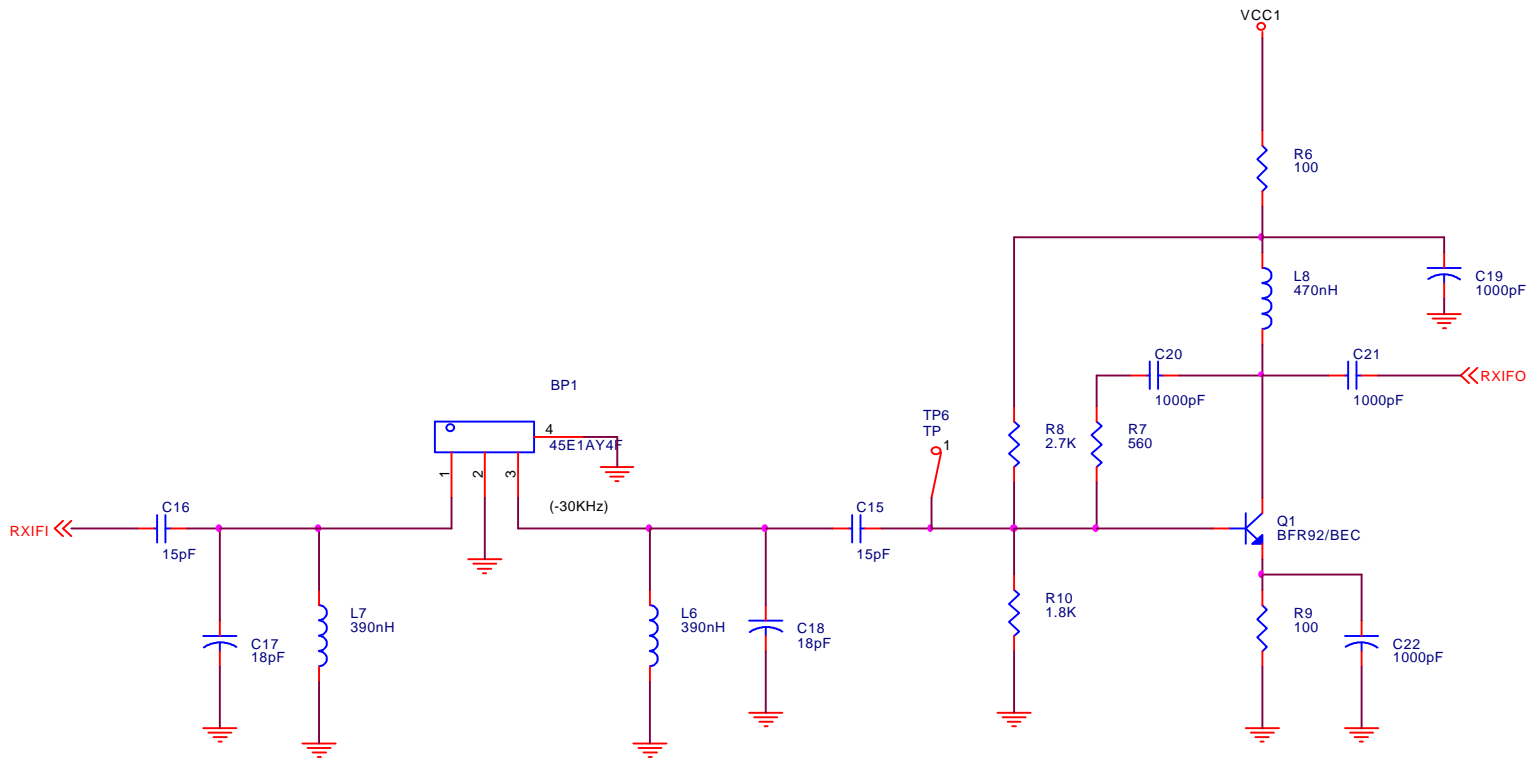

| | | |
|---|-------------------------|-----------------------|
| TeLLUS TECHNOLOGY INC. | | |
| 40990 Encyclopedia Circle, Fremont, CA 94538 | | |
| Drawn By: K. Dunnegan | | |
| Title | | P1005 RF Rx IF FILTER |
| Size | Document Number | Rev |
| B | DR4-3.SCH (30KHz) | |
| Date: | Wednesday, May 19, 1999 | Sheet 3 of 19 |

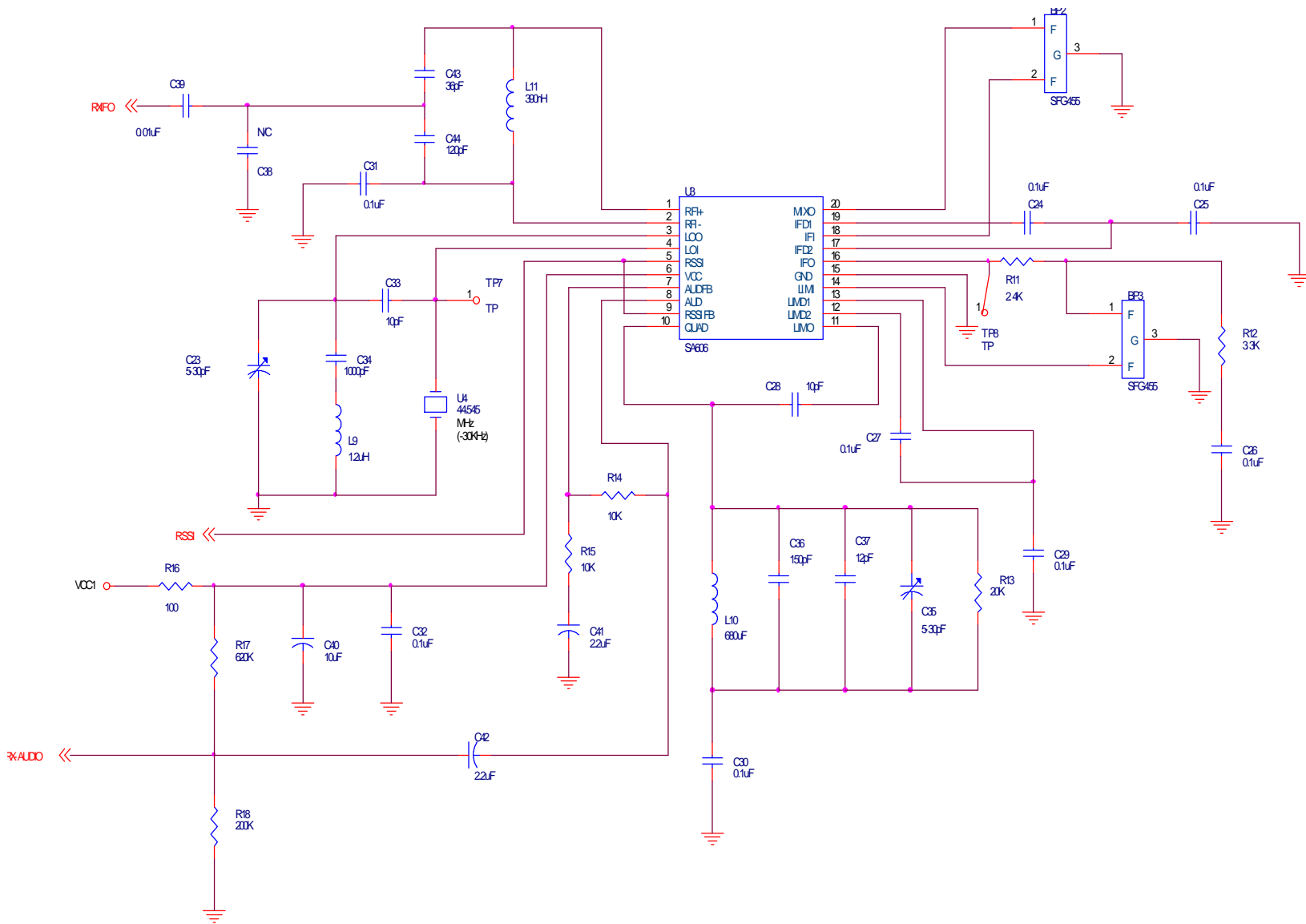

| | | |
|--|-------------------------|---------------|
| TELLE TECHNOLOGY INC. | | |
| 4080 Eroyopeda Circle Fremont, CA 94538 | | |
| Drawn By: K. Dumegan | | |
| Title | | P1005 RF FMIF |
| Size | Document Number | Rev |
| B | DR14 SCH (30KHz) | |
| Date: | Wednesday, May 19, 1999 | Sheet 4 of 19 |

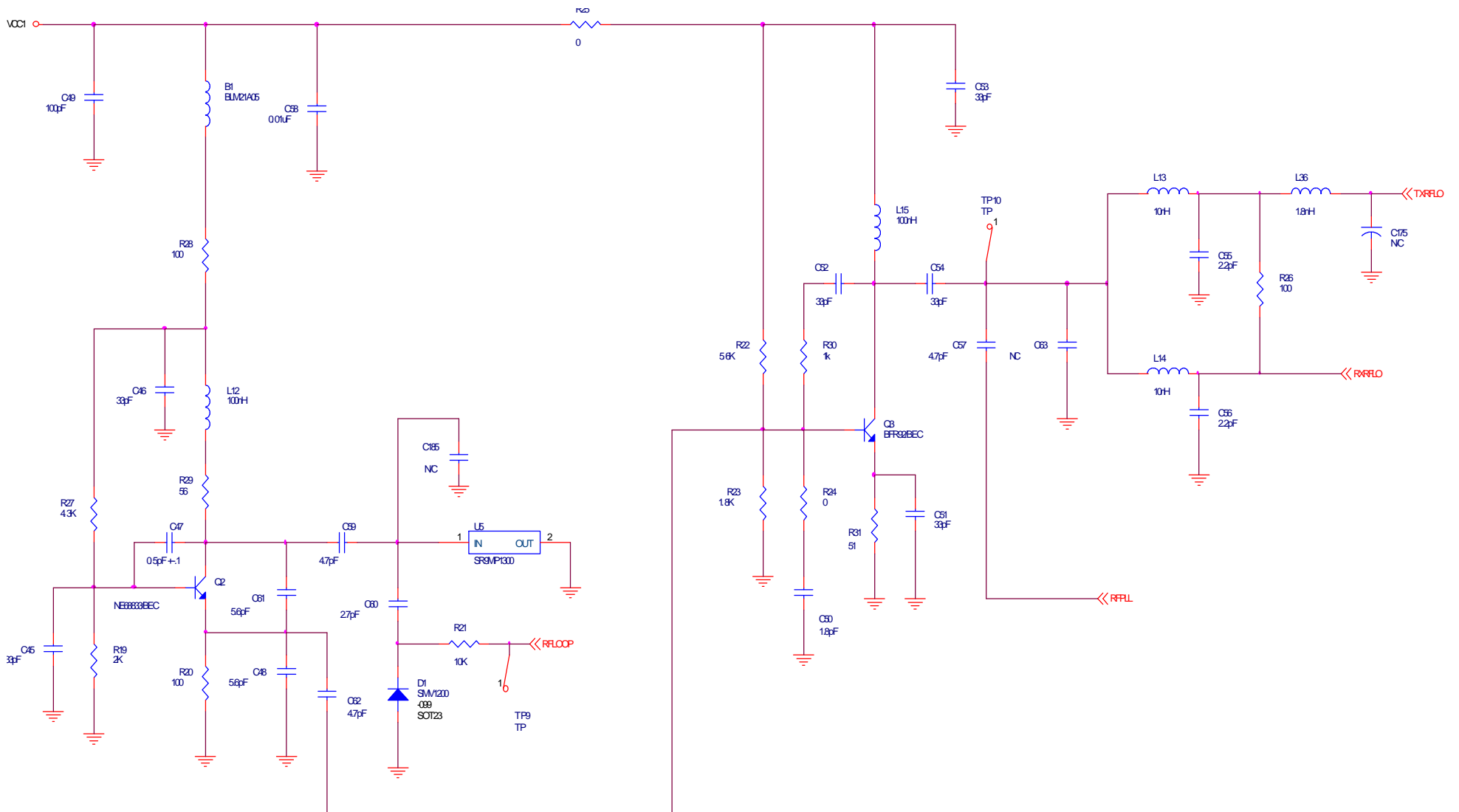

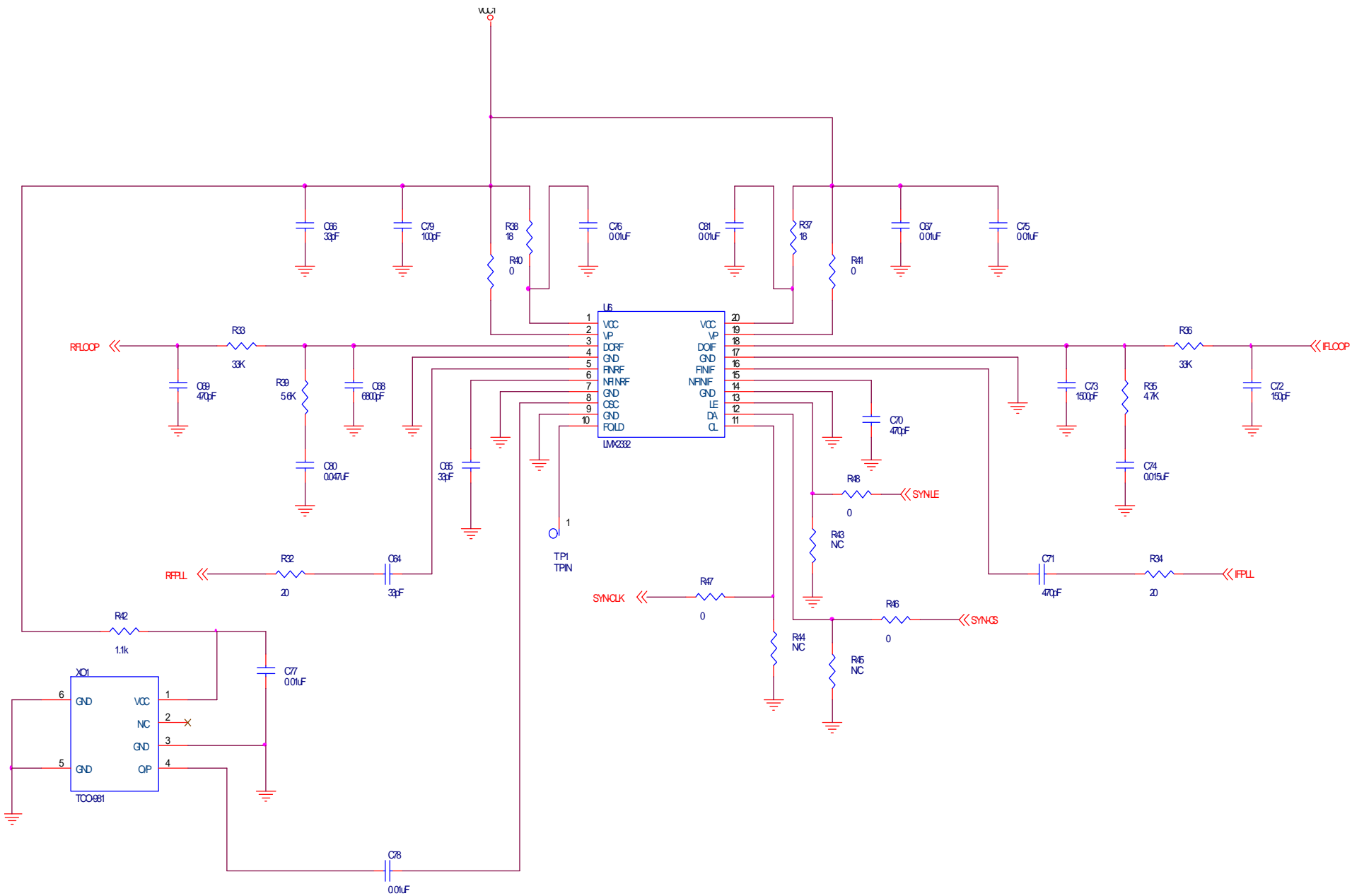

| | | |
|---|-------------------------------------|---------------|
| TELUS TECHNOLOGY INC. | | |
| 40380 Erydopeck Circle Fremont, CA 94538 | | |
| Drawn By: K. Dumegan | | |
| Title P1005 RF DUAL PLL | | |
| She B | Document Number D46SCH (3/14-15) | Rev |
| Date | Worksheets: 1/15/10 10:00 | Sheet 6 of 10 |

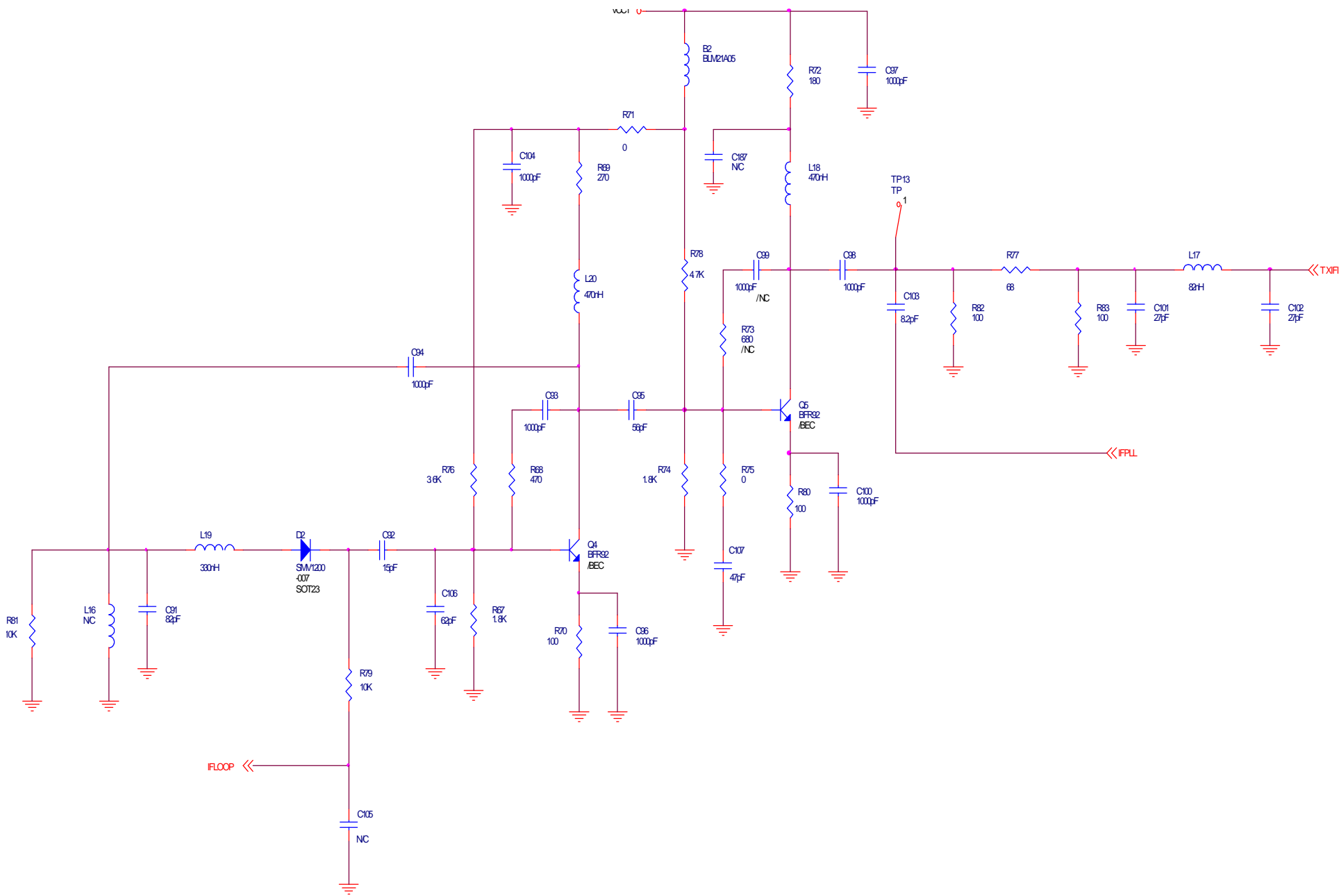

| | | |
|--|-------------------------------------|----------------|
| TELLUS TECHNOLOGY INC. 40990 Encyclopedia Circle Fremont, CA 94538 | | |
| Drawn By: K. Dummegan | | |
| Title P1005 RF 90MHz VCO | | |
| Size B | Document Number DR48 SCH (304-t) | Rev |
| Date: | Wednesday, May 19 1999 | ESheet 8 of 19 |

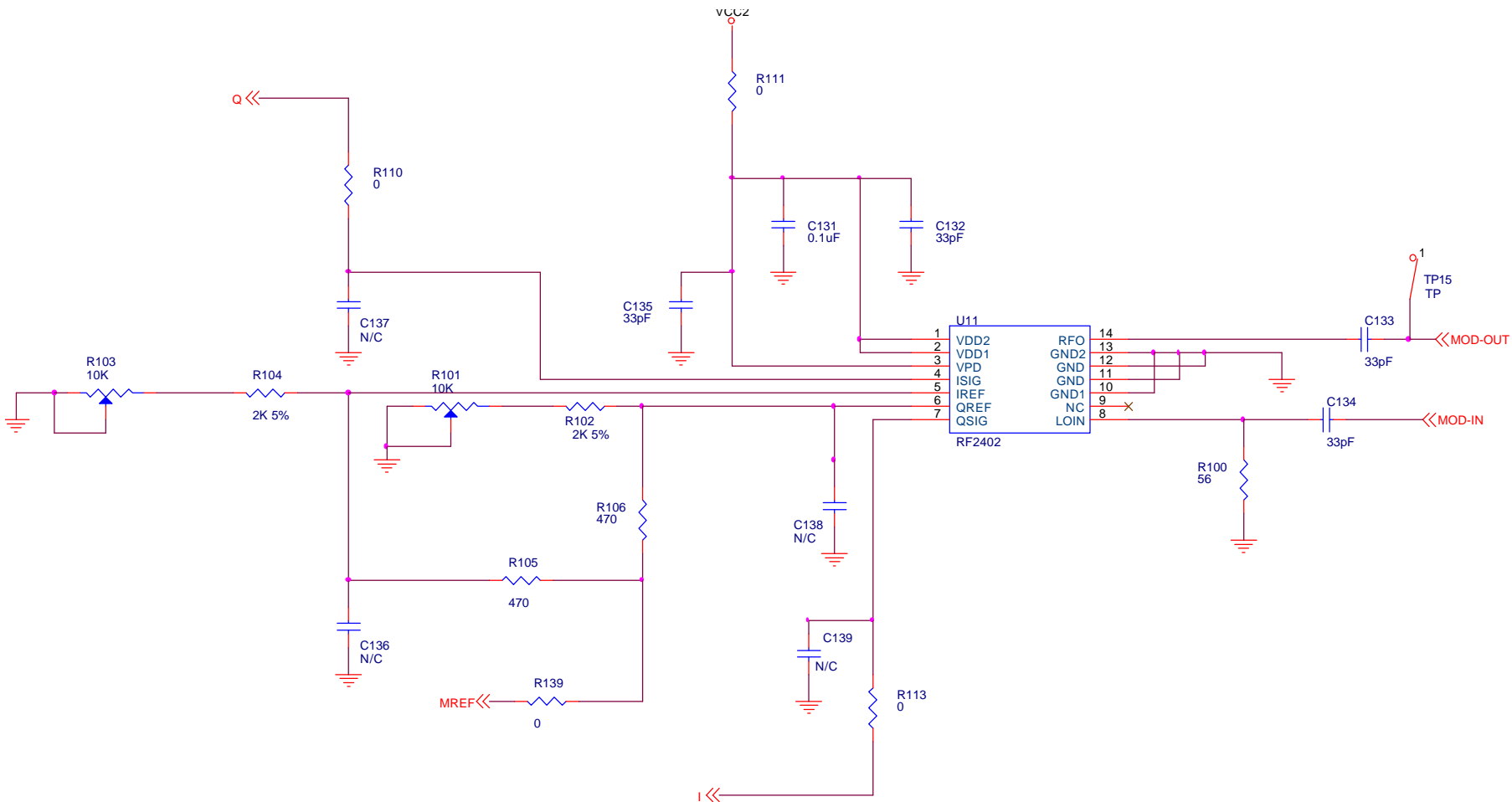

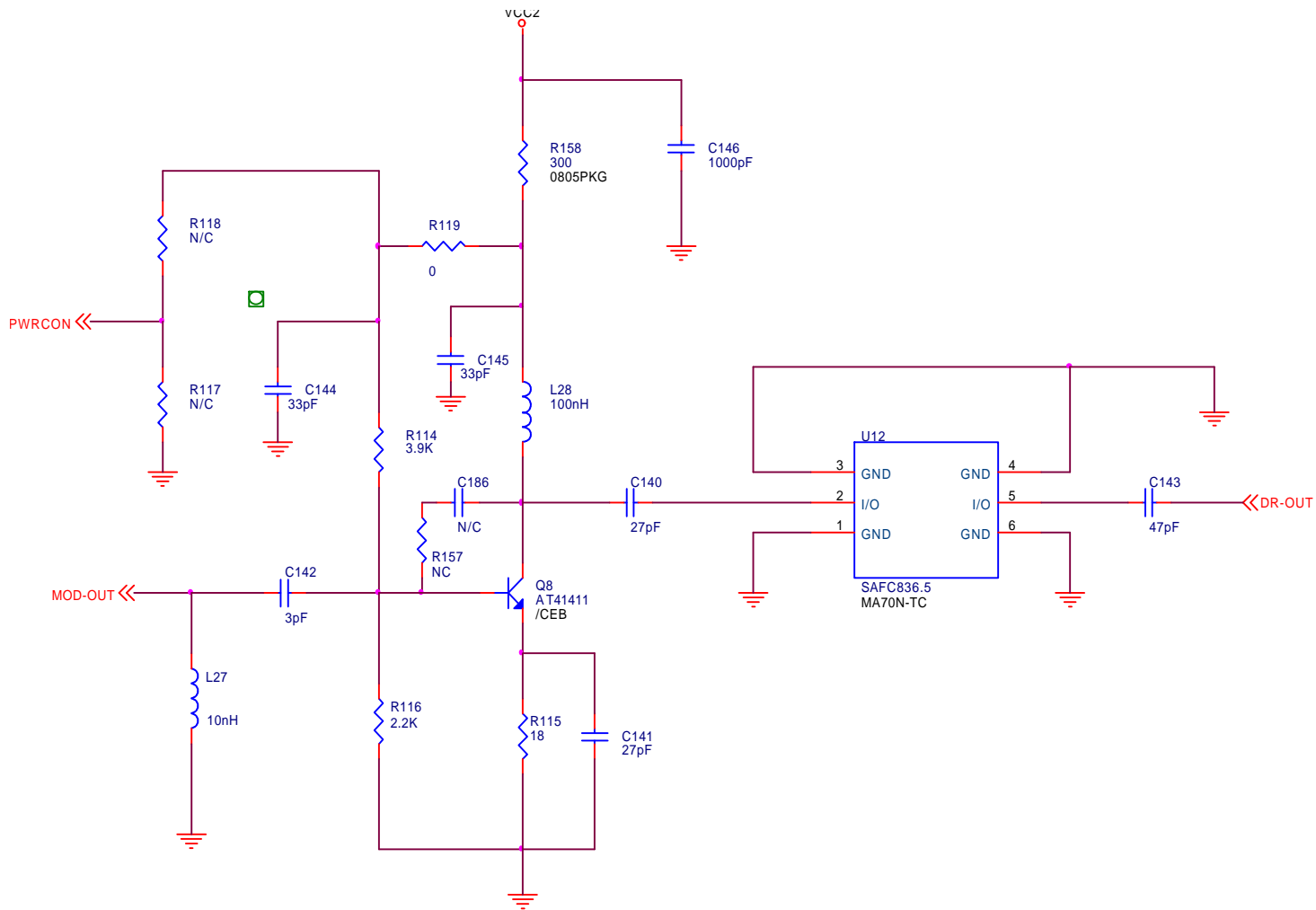

| | | |
|--|---------------------------------------|---------------------------|
| TeLLUS TECHNOLOGY INC. | | |
| 40990 Encyclopedia Circle Fremont, CA 94538 | | |
| Drawn By: K.Dunnegan | | |
| Title | | P1005 RF DRIVER AMPLIFIER |
| Size B | Document Number DR4-11.SCH (30KHz) | Rev |
| Date: | Wednesdav, Mav 19, 1999 | Sheet 11 of 19 |

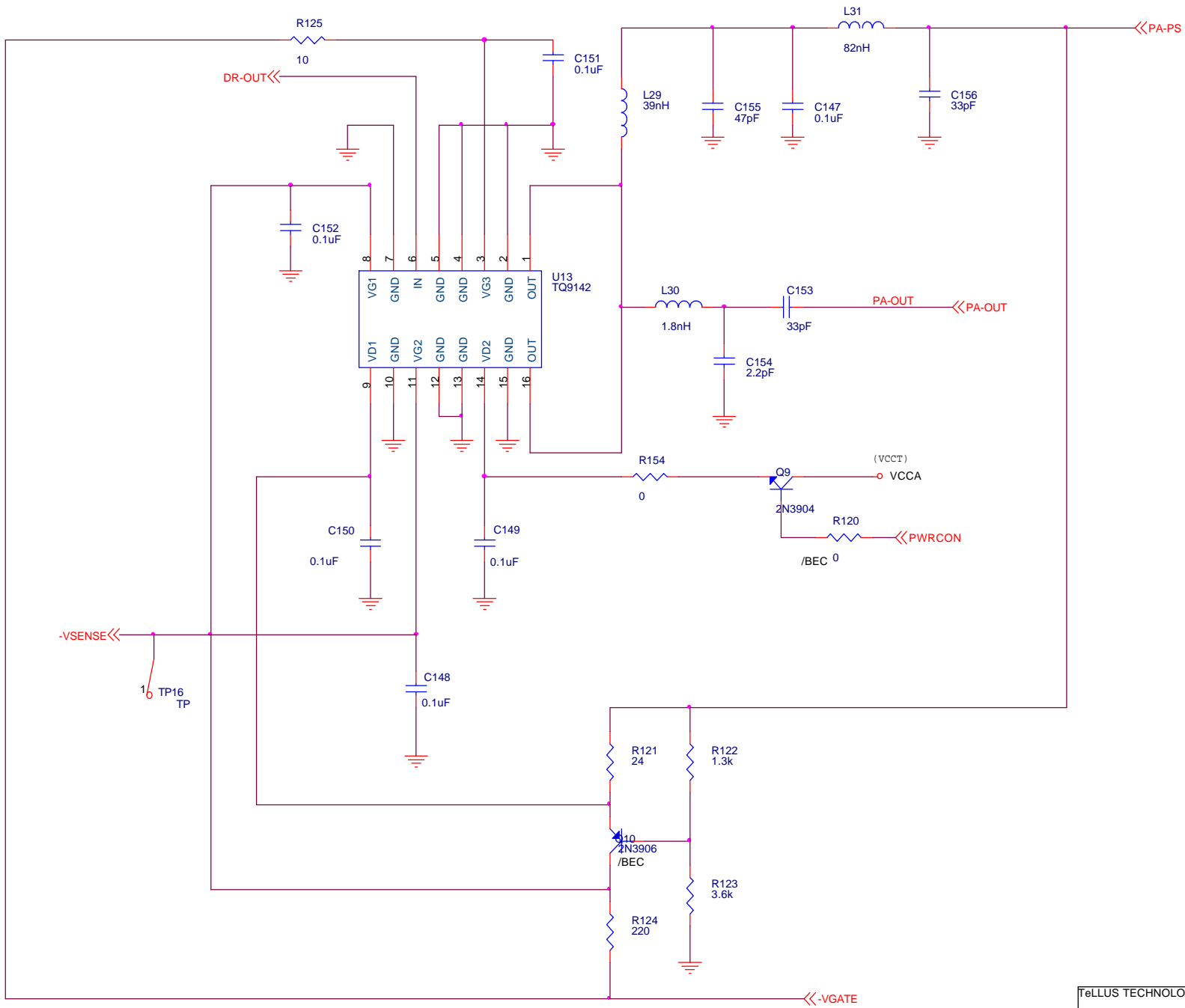

| | | |
|--|---------------------------------------|-------|
| TeLLUS TECHNOLOGY INC. | | |
| 40990 Encyclopedia Circle Fremont, CA 94538 | | |
| Drawn By: Ken Dunnegan | | |
| Title P1005 RF POWER AMPLIFIER | | |
| Size B | Document Number DR4-12.SCH (30KHz) | Rev |
| Date: Wednesday, May 19, 1999 | Sheet 12 | of 19 |

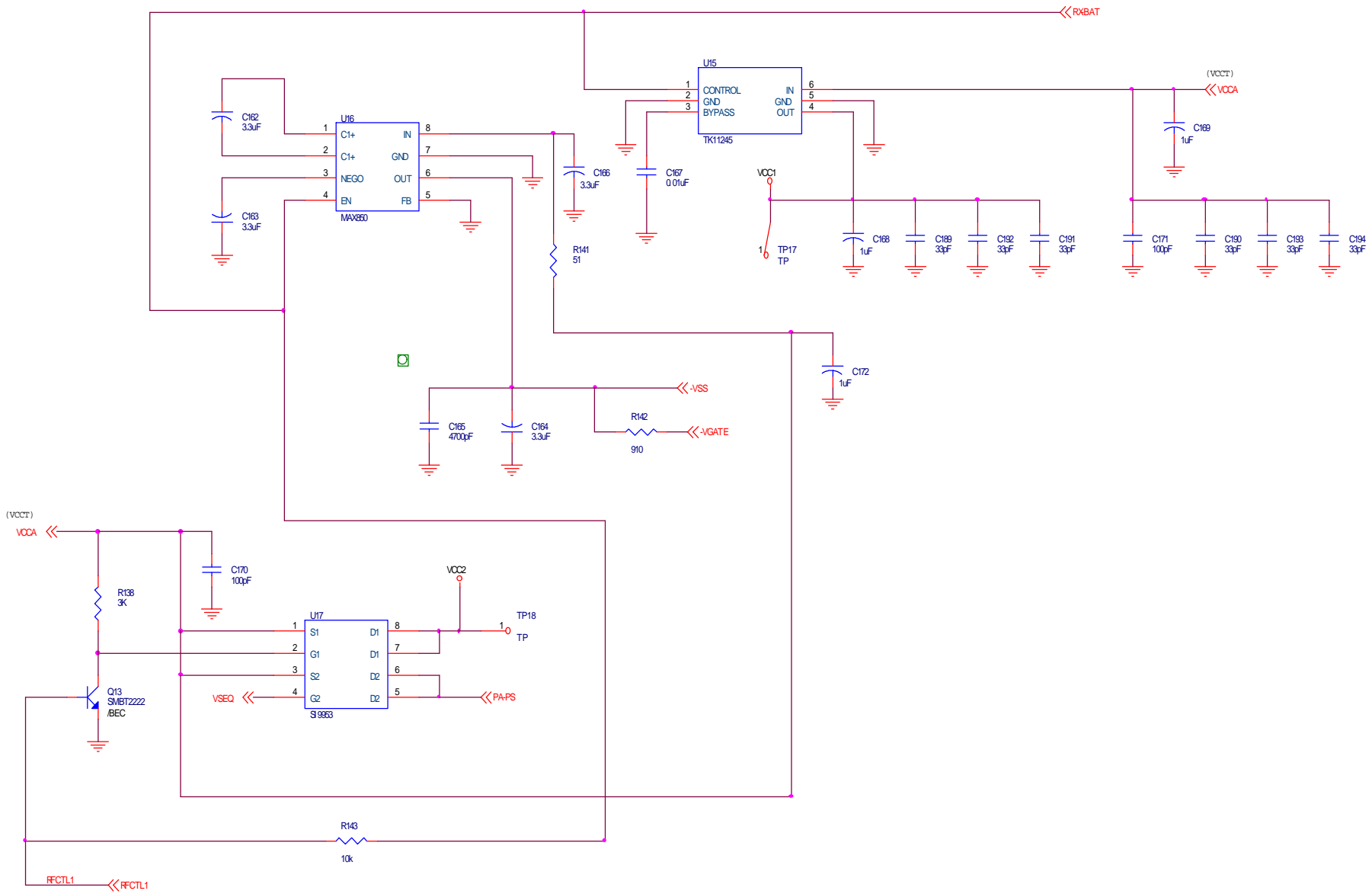

| | | |
|--|-------------------------------------|-------|
| FALUS TECHNOLOGY INC. | | |
| 40990 Encyclopedia Circle Fremont, CA 94538 | | |
| Drawn By: K. Dunnegan | | |
| Title: P1005 RF DC Power Distribution | | |
| Size: B | Document Number: DR4-14.SCH (30KHz) | Rev: |
| Date: Wednesday, May 19, 1999 | Sheet: 14 | of 19 |

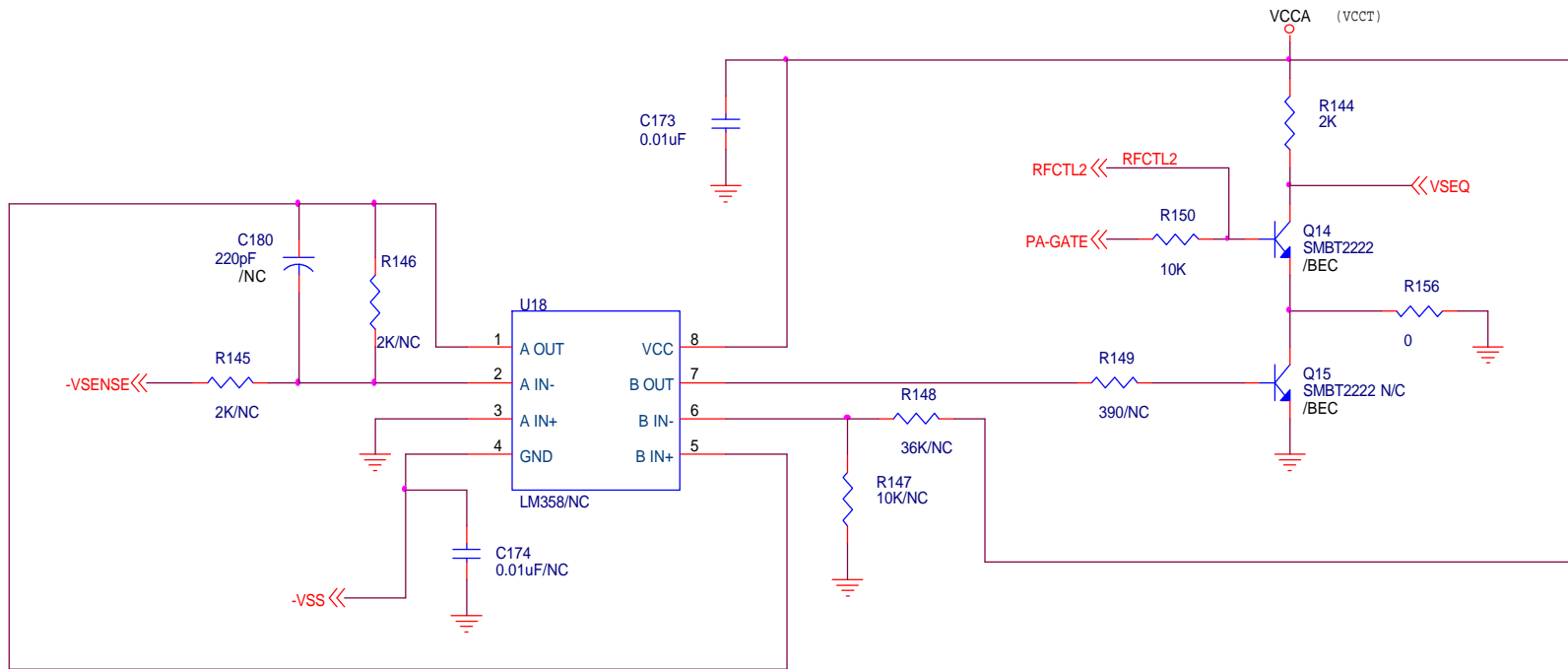

| | | |
|--|---------------------------------------|-------|
| TeLLUS TECHNOLOGY INC. | | |
| 40990 Encyclopedia Circle Fremont, CA 94538 | | |
| Drawn By: K. Dunnegan | | |
| Title P1005 RF PA POWER SUPPLY SEQUENCER | | |
| Size B | Document Number DR4-15.SCH (30KHz) | Rev |
| Date: Wednesday, May 19, 1999 | Sheet 15 | of 19 |

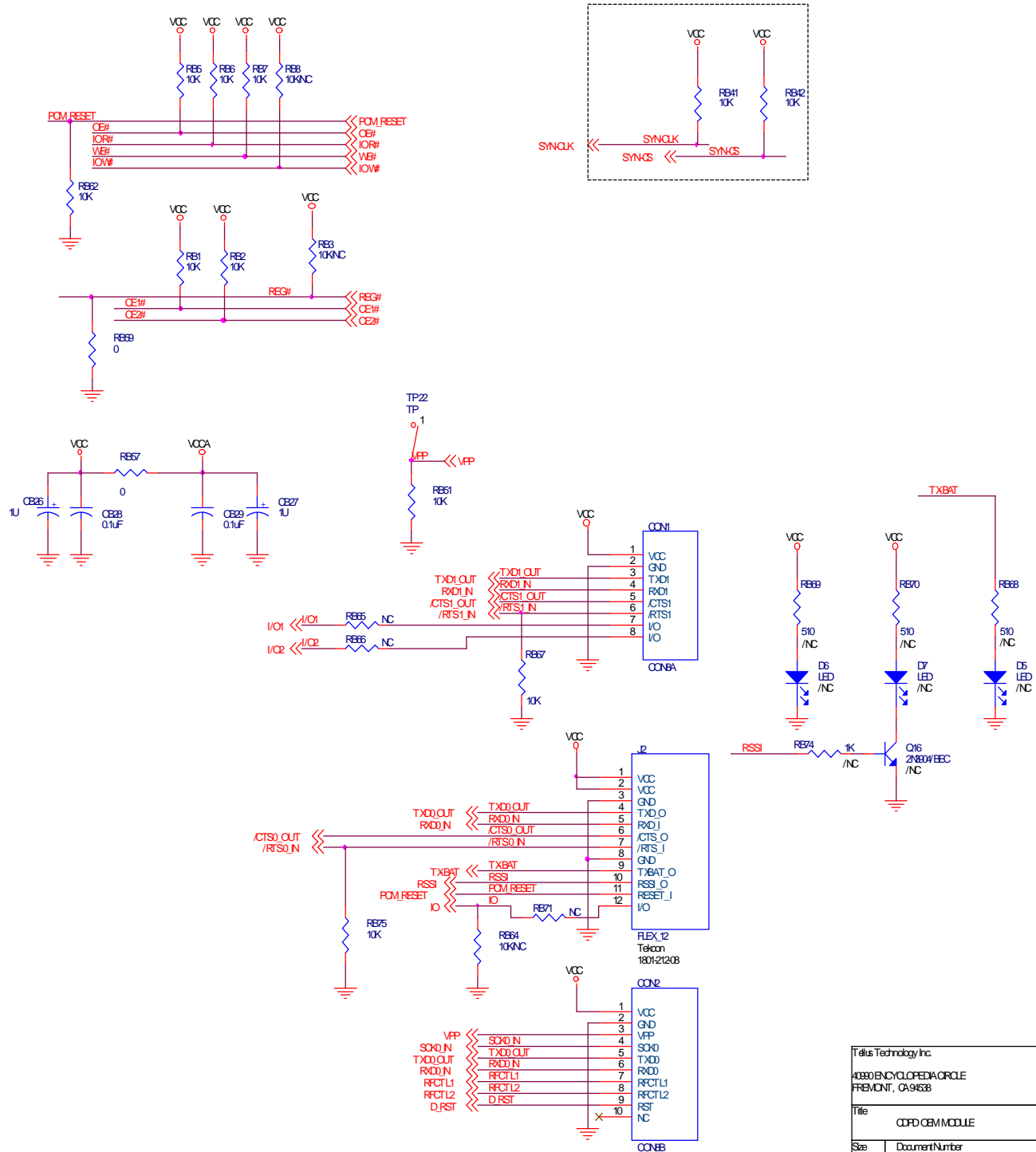

| | | |
|---------------------------|-------------------------|----------------|
| Telus Technology Inc. | | |
| 43300 ENCYCLOPEDIA CIRCLE | | |
| FREMONT, CA 94538 | | |
| Title | | |
| CDPD CEM MODULE | | |
| Size | Document Number | Rev |
| B | UART INTERFACE | A1 |
| Date: | Wednesday, May 19, 1999 | Sheet 16 of 19 |

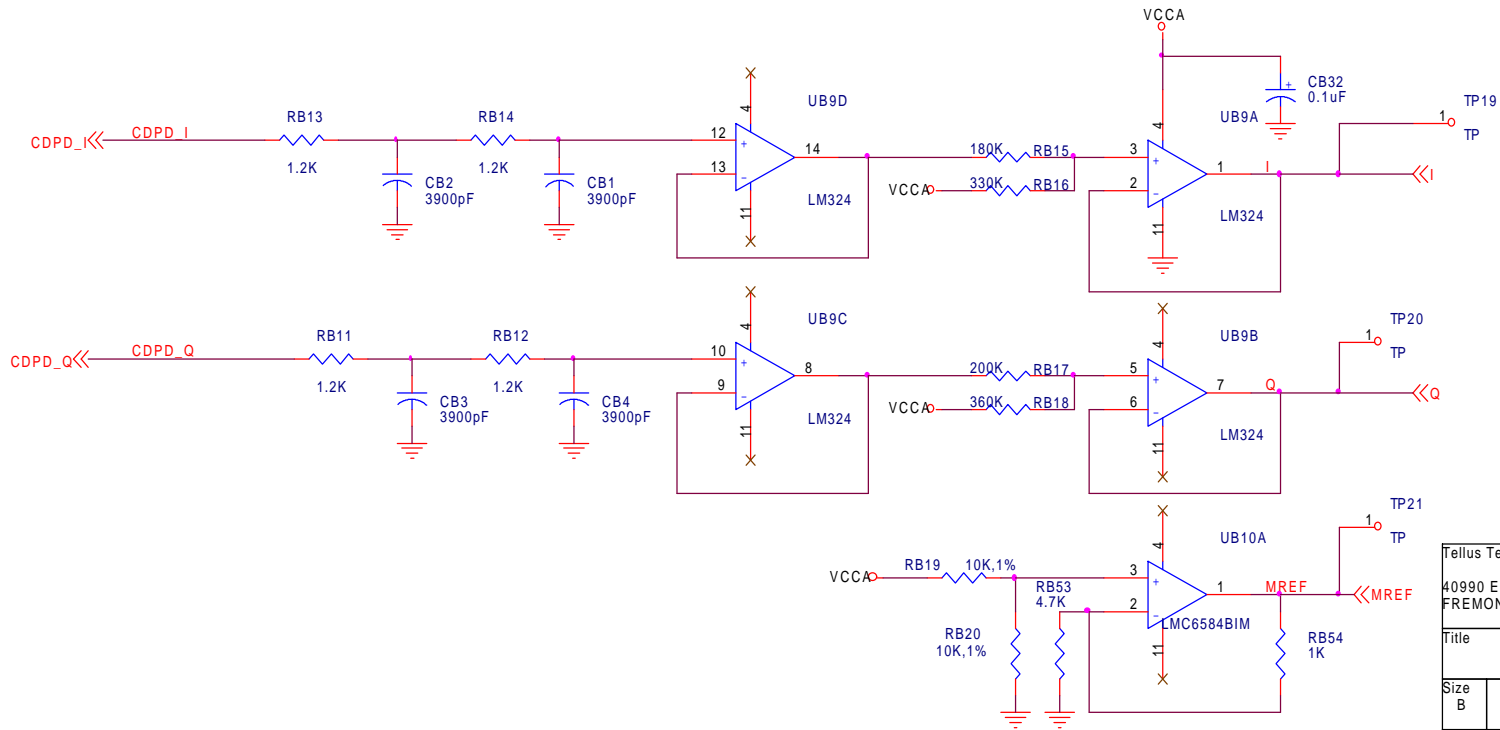
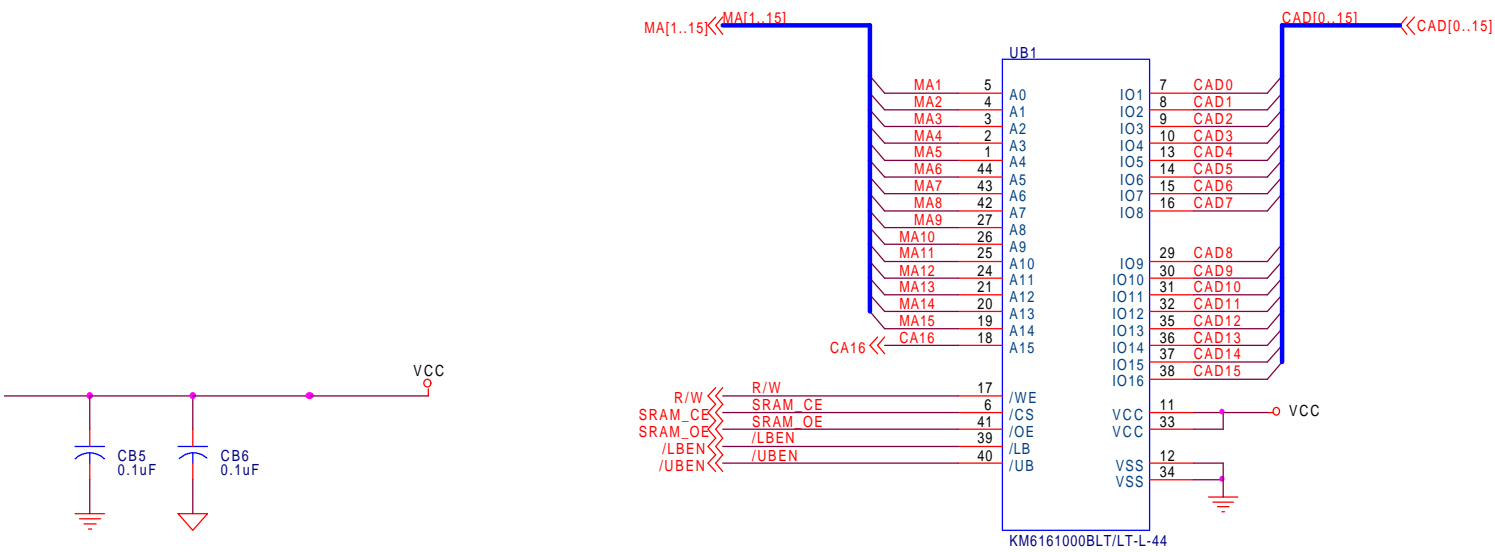

| | | |
|--|---|----------------|
| Tellus Technology Inc. | | |
| 40990 ENCYCLOPEDIA CIRCLE FREMONT, CA 94538 | | |
| Title CDPD OEM MODULE | | |
| Size B | Document Number MEMORY AND I/Q INTERFACE | Rev A1 |
| Date: | Wednesday, May 19, 1999 | Sheet 17 of 19 |

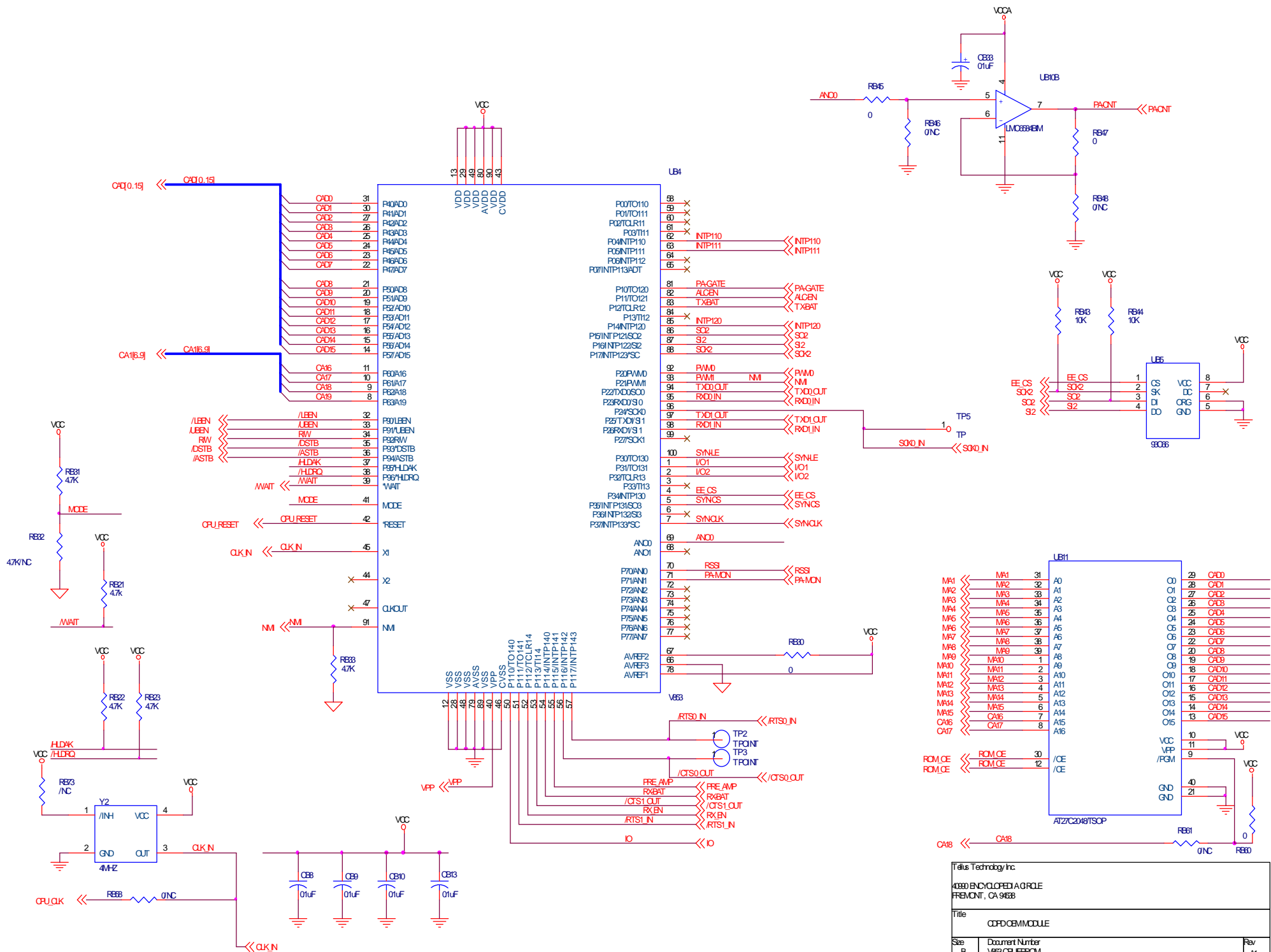

| | | | |
|---|------------------------|-------|----------|
| Titius Technology Inc. | | | |
| 4880 ENCYCLOPEDIA CIRCLE FREMONT, CA 94538 | | | |
| Title | | | |
| CPU/CBM MODULE | | | |
| Size | Document Number | Rev | |
| B | V85 CPU/ROM | A1 | |
| Date: | Wednesday, May 19 1989 | Sheet | 18 of 19 |

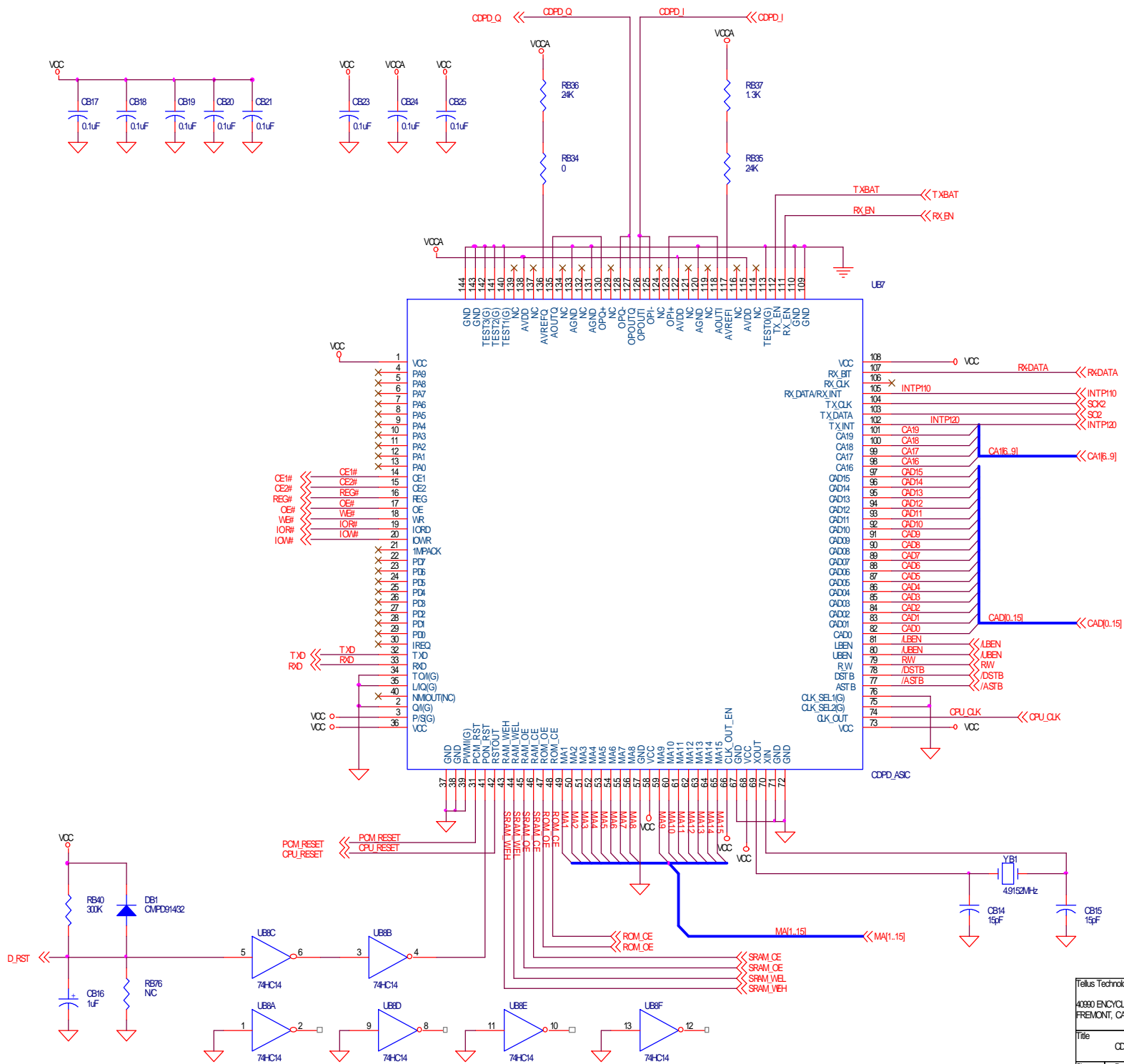

| | | |
|--|-----------------------------|-----------|
| Telus Technology Inc. | | |
| 40890 ENCYCLOPEDIA CIRCLE FREMONT, CA 94538 | | |
| Title COPD OB MODULE | | |
| Size B | Document Number COPD_ASC | Rev A1 |
| Date: Wednesday, May 19, 1999 | Sheet 19 | of 19 |

