



FCC RADIO TEST REPORT

FCC ID : NYOSYECFWPC1806
Equipment : Wireless Charging System
Brand Name : HYUNDAI
Model Name : SYECFWPC1806
Applicant : SEOYON ELECTRONICS Co.,Ltd
100, Saneop-ro 156beon-gil, Gwonseon-gu,
Suwon-si, Gyeonggi-do, South Korea
Manufacturer : SEOYON ELECTRONICS Co.,Ltd
100, Saneop-ro 156beon-gil, Gwonseon-gu,
Suwon-si, Gyeonggi-do, South Korea
Standard : 47 CFR FCC Part 15.209

The product was received on Mar. 28, 2018, and testing was started from Apr. 10, 2018 and completed on Apr. 11, 2018. We, SPORTON INTERTIONAL INC. EMC & Wireless Communications Laboratory, would like to declare that the tested sample has been evaluated in accordance with the procedures given in ANSI C63.10-2013 and shown compliance with the applicable technical standards.

The report must not be used by the client to claim product certification, approval, or endorsement by TAF or any agency of government.

The test results in this report apply exclusively to the tested model / sample. Without written approval of SPORTON INTERTIONAL INC. EMC & Wireless Communications Laboratory, the test report shall not be reproduced except in full.

Approved by: Allen Lin

SPORTON INTERTIONAL INC. EMC & Wireless Communications Laboratory

No. 52, Huaya 1st Rd., Guishan Dist., Taoyuan City, Taiwan (R.O.C.)



Table of Contents

- 1 GENERAL DESCRIPTION5**
- 1.1 Information.....5
- 1.2 Testing Applied Standards6
- 1.3 Testing Location Information.....6
- 1.4 Measurement Uncertainty6
- 2 TEST CONFIGURATION OF EUT.....7**
- 2.1 The Worst Case Configuration7
- 2.2 The Worst Charger Frequencies Configuration7
- 2.3 The Worst Case Measurement Configuration.....7
- 2.4 Support Equipment.....8
- 2.5 Test Setup Diagram9
- 3 TRANSMITTER TEST RESULT10**
- 3.1 AC Power-line Conducted Emissions10
- 3.2 Transmitter Radiated Emissions12
- 3.3 Emission Bandwidth20
- 4 TEST EQUIPMENT AND CALIBRATION DATA22**

APPENDIX A. TEST PHOTOS

PHOTOGRAPHS OF EUT v01



Summary of Test Result

Report Clause	Ref Std. Clause	Test Items	Result (PASS/FAIL)	Remark
1.1.2	15.203	Antenna Requirement	PASS	-
3.1	15.207	AC Power-line Conducted Emissions	Not Required	-
3.2	15.209	Transmitter Radiated Emissions	PASS	-
3.3	15.215(c)	Emission Bandwidth	PASS	-

Reviewed by: Sam Tsai

Report Producer: Amber Chiu

1 General Description

1.1 Information

1.1.1 General Information

Wireless Power Transfer General Information			
Frequency Range	Modulation	Charging Freq. (kHz)	Field Strength (dBuV/m)
110-115 kHz	ASK	110.90	87.12
Power Transfer Method	Output power from each primary coil	Max. coupling surface area	Charging Method
Magnetic induction and only single primary coil coupling secondary coil	<5W	59.28 cm ²	Client directly contact

Note 1: Field strength performed peak level at 3m.

1.1.2 Antenna Information

Antenna Category	
<input type="checkbox"/>	Equipment placed on the market without antennas
<input checked="" type="checkbox"/>	Integral antenna (antenna permanently attached)
<input type="checkbox"/>	External antenna (dedicated antennas)

1.1.3 Type of EUT

Identify EUT	
Presentation of Equipment	<input checked="" type="checkbox"/> Production ; <input type="checkbox"/> Pre-Production ; <input type="checkbox"/> Prototype
Type of EUT	
<input checked="" type="checkbox"/>	Stand-alone
<input type="checkbox"/>	Combined (EUT where the radio part is fully integrated within another device) Combined Equipment - Brand Name / Model No.:
<input type="checkbox"/>	Plug-in radio (EUT intended for a variety of host systems) Host System - Brand Name / Model No.:
<input type="checkbox"/>	Other:

1.1.4 Test Signal Duty Cycle

Operated Mode for Worst Duty Cycle	
<input type="checkbox"/>	Operated normally mode for worst duty cycle
<input checked="" type="checkbox"/>	Operated test mode for worst duty cycle
Test Signal Duty Cycle (x)	
<input checked="" type="checkbox"/>	100%

1.1.5 EUT Operational Condition

Supply Voltage	<input type="checkbox"/> AC mains	<input checked="" type="checkbox"/> DC	
Type of DC Source	<input type="checkbox"/> Internal DC supply	<input type="checkbox"/> External DC adapter	<input checked="" type="checkbox"/> From DC Supply

1.2 Testing Applied Standards

According to the specifications of the manufacturer, the EUT must comply with the requirements of the following standards:

- ♦ 47 CFR FCC Part 15
- ♦ ANSI C63.10-2013
- ♦ KDB680106 D01 RF Exposure Wireless Charging Apps v03

1.3 Testing Location Information

Testing Location			
<input checked="" type="checkbox"/>	HWA YA	ADD : No. 52, Huaya 1st Rd., Guishan Dist., Taoyuan City, Taiwan (R.O.C.)	
		TEL : 886-3-327-3456	FAX : 886-3-327-0973
Test site Designation No. TW1190 with FCC.			
<input type="checkbox"/>	JHUBEI	ADD : No.8, Ln. 724, Bo'ai St., Zhubei City, Hsinchu County, Taiwan (R.O.C.)	
		TEL : 886-3-656-9065	FAX : 886-3-656-9085
Test site Designation No. TW0006 with FCC.			

Test Condition	Test Site No.	Test Engineer	Test Environment	Test Date
Radiated Emission	03CH03-HY	Jeff	23.2°C / 54%	10/Apr/2018

1.4 Measurement Uncertainty

ISO/IEC 17025 requires that an estimate of the measurement uncertainties associated with the emissions test results be included in the report. The measurement uncertainties given below are based on a 95% confidence level (based on a coverage factor (k=2))

Measurement Uncertainty			
Test Item		Uncertainty	Limit
Radio Frequency		$\pm 6.7 \times 10^{-8}$	$\pm 1 \times 10^{-7}$
All emissions, radiated	9 – 150 kHz	± 2.5 dB	± 6 dB
	0.15 – 30 MHz	± 2.3 dB	± 6 dB
	30 – 1000 MHz	± 2.6 dB	± 6 dB
Temperature		± 0.8 °C	± 1 °C
Humidity		± 5 %	± 5 %
DC and low frequency voltages		± 0.9 %	± 3 %

2 Test Configuration of EUT

2.1 The Worst Case Configuration

Modulation Mode	Field Strength (dBuV/m at 3m)
ASK	87.12
Wireless charger were performed all charging conditions including variable loading and non-charging operation, the worst mode is full charging loading.	

2.2 The Worst Charger Frequencies Configuration

Modulation Mode	Charger Frequencies (kHz)
ASK	110.90
Wireless charger frequencies are variable frequency range (110-115 kHz) and depend on charging loading. The charging frequency is 110.90.	

2.3 The Worst Case Measurement Configuration

The Worst Case Mode for Following Conformance Tests	
Tests Item	Transmitter Radiated Emissions, Emission Bandwidth
Test Condition	Radiated measurement
User Position	<input type="checkbox"/> EUT will be placed in fixed position. <input checked="" type="checkbox"/> EUT will be placed in mobile position and operating multiple positions. <input type="checkbox"/> EUT will be a hand-held or body-worn battery-powered devices and operating multiple positions.
Operating Mode < 1GHz	1. Operating mode
Orthogonal Planes of EUT	<p style="text-align: center;">Z Plane</p> 
Worst Planes of EUT	V



2.4 Support Equipment

Support Equipment – Radiated				
No.	Equipment	Brand Name	Model Name	FCC ID
1	DC Power Supply	G.W	GPS-303ODD	-
2	Wireless charging antenna coils	-	-	-
3	Load	-	-	-

Note: Support equipment No.2 & 3 was provided by customer.

2.5 Test Setup Diagram

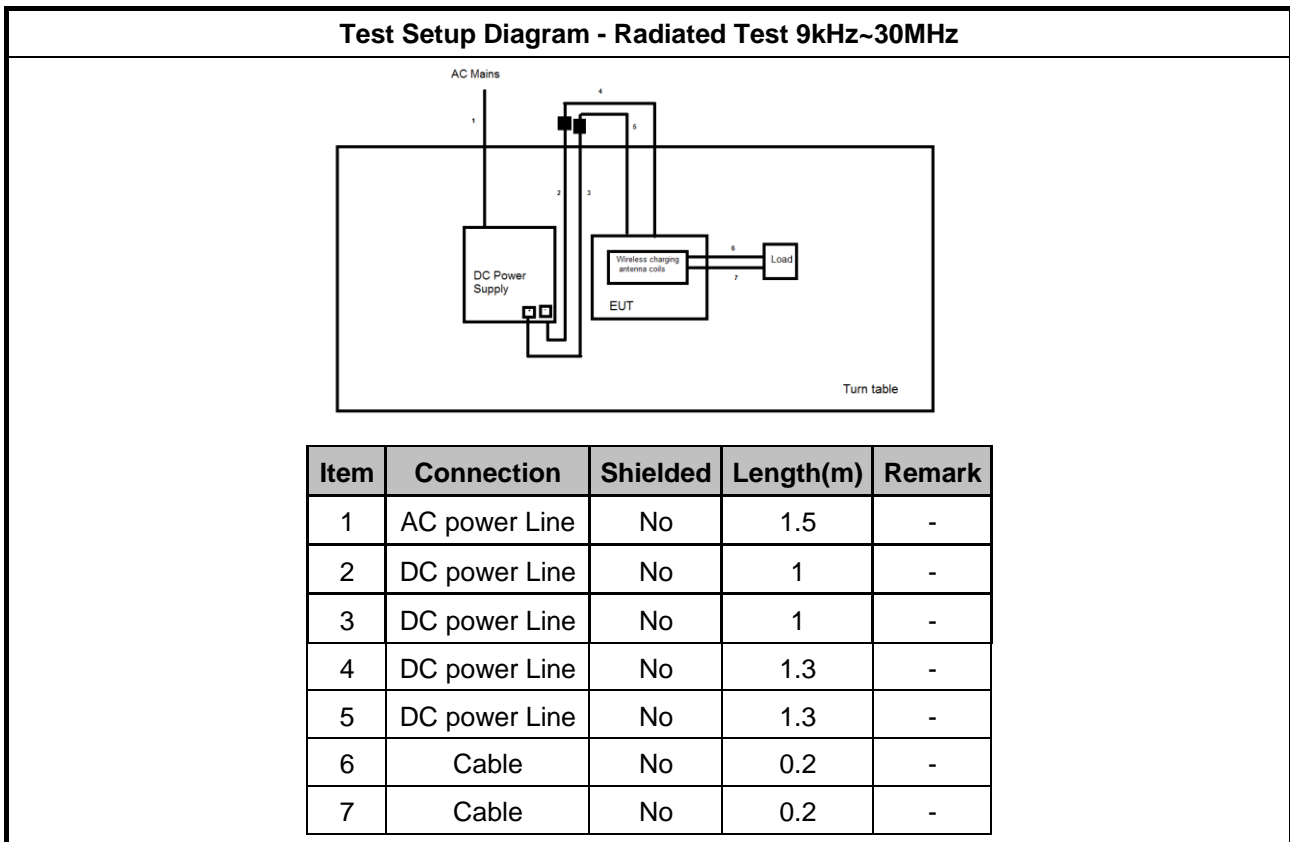

3 Transmitter Test Result

3.1 AC Power-line Conducted Emissions

3.1.1 AC Power-line Conducted Emissions Limit

AC Power-line Conducted Emissions Limit		
Frequency Emission (MHz)	Quasi-Peak	Average
0.15-0.5	66 - 56 *	56 - 46 *
0.5-5	56	46
5-30	60	50

Note 1: * Decreases with the logarithm of the frequency.

3.1.2 Measuring Instruments

Refer a test equipment and calibration data table in this test report.

3.1.3 Test Procedures

Test Method	
<input checked="" type="checkbox"/>	Refer as ANSI C63.10-2013, clause 6.2 for AC power-line conducted emissions.
<input checked="" type="checkbox"/>	If AC conducted emissions fall in operating band, then following below test method confirm final result.
<input type="checkbox"/>	Accept measurements done with a suitable dummy load replacing the antenna under the following conditions: (1) Perform the AC line conducted tests with the antenna connected to determine compliance with FCC 15.207 limits outside the transmitter's fundamental emission band; (2) Retest with a dummy load to determine compliance with FCC 15.207 limits within the transmitter's fundamental emission band.
<input checked="" type="checkbox"/>	For a device with a permanent antenna operating at or below 30 MHz, accept measurements done with a suitable dummy load, in lieu of the permanent antenna under the following conditions: (1) Perform the AC line conducted tests with the permanent antenna to determine compliance with the FCC 15.207 limits outside the transmitter's fundamental emission band; (2) Retest with a dummy load in lieu of the permanent antenna to determine compliance with the FCC 15.207 limits within the transmitter's fundamental emission band.

3.1.4 Test Setup

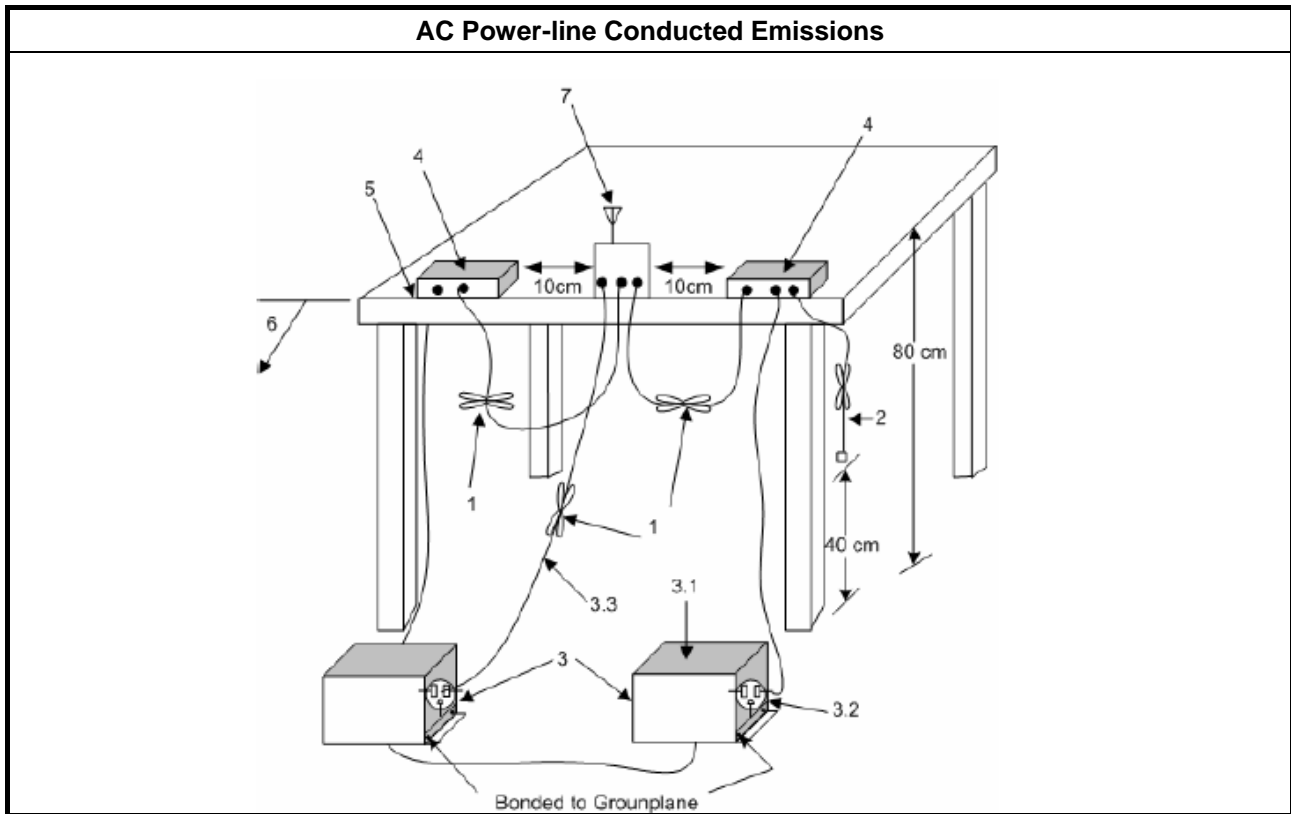

3.1.5 Test Result of AC Power-line Conducted Emissions

Please refer to Part 15.209 which states, "Measurements to demonstrate compliance with the conducted limits are not required for devices employ DC power source for operation and which do not operate from the AC power lines or contain provisions for operation while connected to the AC power lines". Therefore, for this device, AC Power Line Conducted Emissions investigation is not required.



3.2 Transmitter Radiated Emissions

3.2.1 Transmitter Radiated Emissions Limit

Transmitter Radiated Emissions Limit			
Frequency Range (MHz)	Field Strength (uV/m)	Field Strength (dBuV/m)	Measure Distance (m)
0.009~0.490	2400/F(kHz)	48.5 - 13.8	300
0.490~1.705	24000/F(kHz)	33.8 - 23	30
1.705~30.0	30	29	30
30~88	100	40	3
88~216	150	43.5	3
216~960	200	46	3
Above 960	500	54	3

Note 1: Test distance for frequencies at or above 30 MHz, measurements may be performed at a distance other than the limit distance provided they are not performed in the near field and the emissions to be measured can be detected by the measurement equipment. When performing measurements at a distance other than that specified, the results shall be extrapolated to the specified distance using an extrapolation factor of 20 dB/decade (inverse of linear distance for field-strength measurements, inverse of linear distance-squared for power-density measurements).

Note 2: Test distance for frequencies at below 30 MHz, measurements may be performed at a distance closer than the EUT limit distance; however, an attempt should be made to avoid making measurements in the near field. When performing measurements below 30 MHz at a closer distance than the limit distance, the results shall be extrapolated to the specified distance by either making measurements at a minimum of two or more distances on at least one radial to determine the proper extrapolation factor or by using the square of an inverse linear distance extrapolation factor (40 dB/decade). The test report shall specify the extrapolation method used to determine compliance of the EUT.

Note 3: the frequency bands 9-90 kHz, 110-490 kHz measurements employing an average detector and other below 1GHz measurements employing a CISPR quasi-peak detector.

3.2.2 Measuring Instruments

Refer a test equipment and calibration data table in this test report.



3.2.3 Test Procedures

Test Method	
<input checked="" type="checkbox"/>	Refer as ANSI C63.10, clause 6.5 for radiated emissions from 30 MHz to 1 GHz and test distance is 1m.
<input checked="" type="checkbox"/>	Refer as ANSI C63.10, clause 6.4 for radiated emissions from below 30 MHz the frequency bands 394 kHz, 370-398kHz measurements employing an average detector and other below 30MHz measurements employing a CISPR quasi-peak detector. Test distance is 1m.
<input checked="" type="checkbox"/>	At frequencies below 30 MHz, measurements may be performed at a distance closer than that specified in the requirements; however, an attempt should be made to avoid making measurements in the near field. Pending the development of an appropriate measurement procedure for measurements performed below 30 MHz, when performing measurements at a closer distance than specified, the results shall be following below methods.
<input type="checkbox"/>	The results shall be extrapolated to the specified distance by making measurements at a minimum of two distances on at least one radial to determine the proper extrapolation factor.
<input checked="" type="checkbox"/>	The results shall be by using the square of an inverse linear distance extrapolation factor (40 dB/decade).
<input checked="" type="checkbox"/>	For radiated measurement. Loop antenna was rotated about the horizontal and vertical axis and the equipment to be measured and the test antenna shall be oriented to obtain the maximum emitted field strength level.
<input checked="" type="checkbox"/>	The any unwanted emissions level shall not exceed the fundamental emission level.
<input checked="" type="checkbox"/>	All amplitude of spurious emissions that are attenuated by more than 20 dB below the permissible value has no need to be reported.

3.2.4 Test Setup

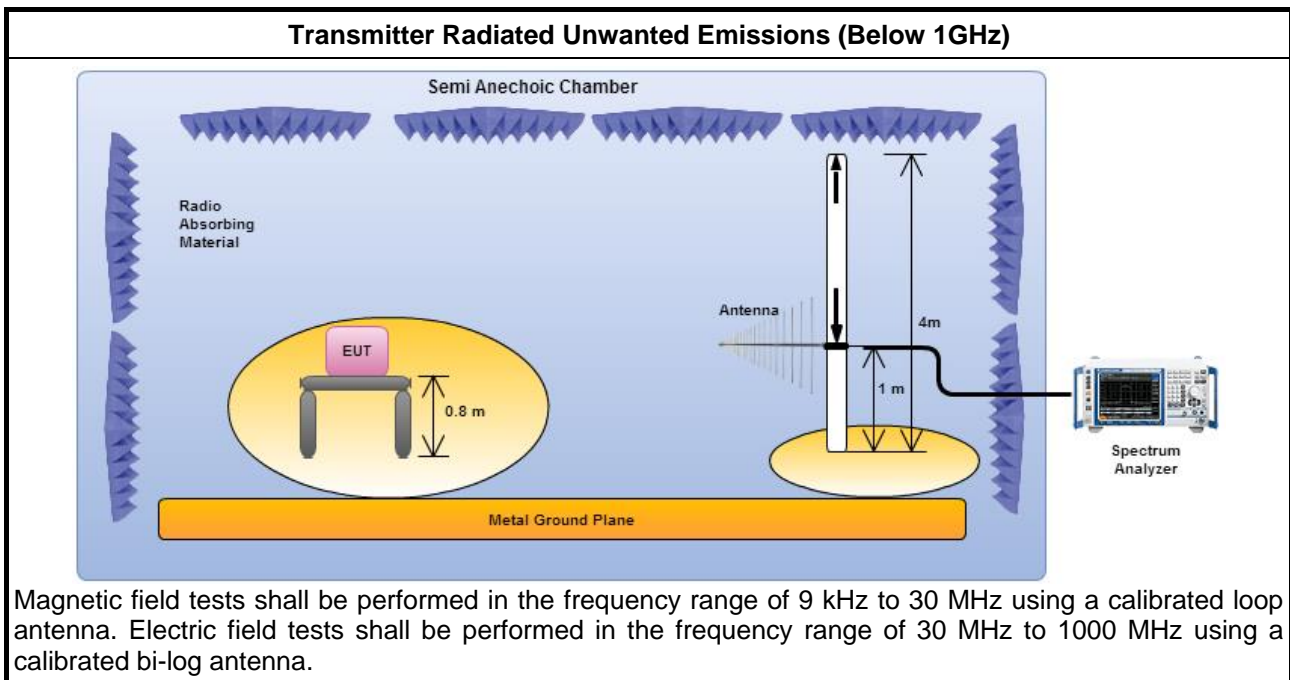
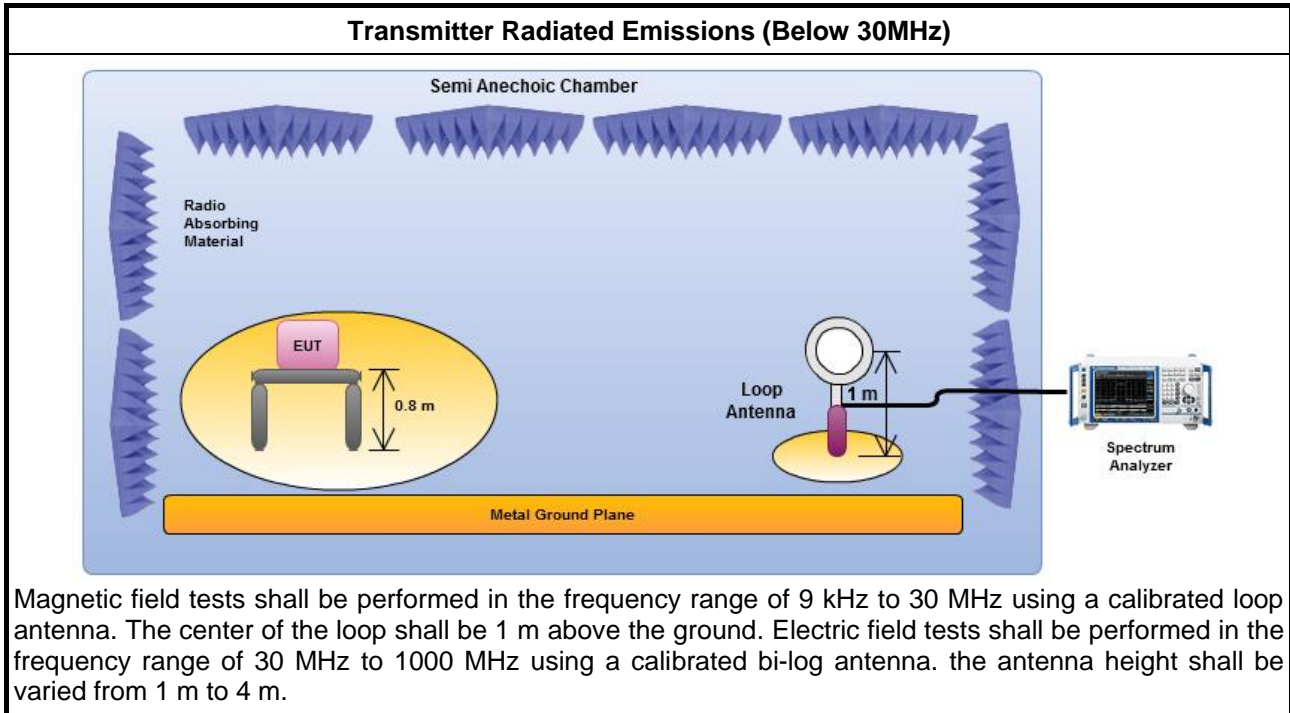



3.2.5 Transmitter Radiated Emissions (Below 30MHz)

Transmitter Radiated Emissions (110.90kHz)			
Modulation Mode	ASK	Polarization	H
Operating Mode	1	Operating Function	Wireless Charger

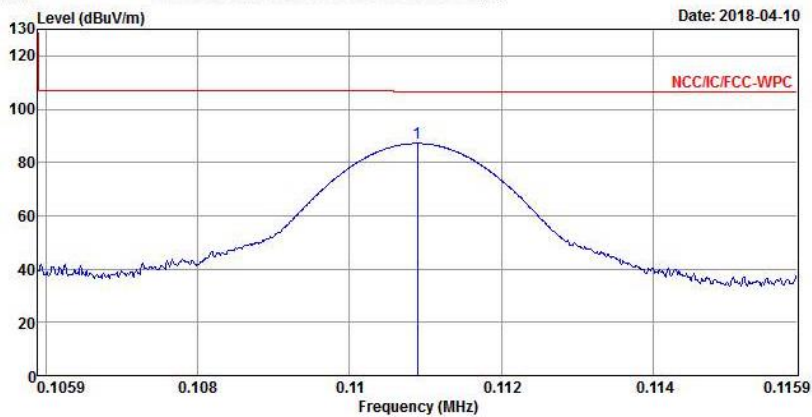

	Freq	Level	Over Limit	Limit Line	ReadAntenna Level	Cable Loss	Preamp Factor	Remark	A/Pos	T/Pos
	MHz	dBuV/m	dB	dBuV/m	dBuV	dB/m	dB	dB	cm	deg
1	0.11090	87.12	-19.59	106.71	66.35	20.69	0.08	0.00 Peak	100	344

- Note 1: ">20dB" means spurious emission levels that exceed the level of 6 dB below the applicable limit.
- Note 2: "N/F" means Nothing Found spurious emissions (No spurious emissions were detected.)
- Note 3: Measurement worst emissions of receive antenna polarization: H(Horizontal).
- Note 4: No level of unwanted emissions exceeds the level of the fundamental emission.
- Note 5: Except fundamental emission, other emissions from digital circuitry used to control additional panel functions or display capabilities other than the touch panel radio transmission. While disable touch panel radio transmission, other emissions have the same levels. Therefore other emissions level could be exceed the fundamental emission level.
- Note 6: The test result in peak detector is less than average limit , so that we tested in peak detector only.



Transmitter Radiated Emissions (9 kHz – 150 kHz)

Modulation Mode	ASK	Polarization	H
Operating Mode	1	Operating Function	Wireless Charger

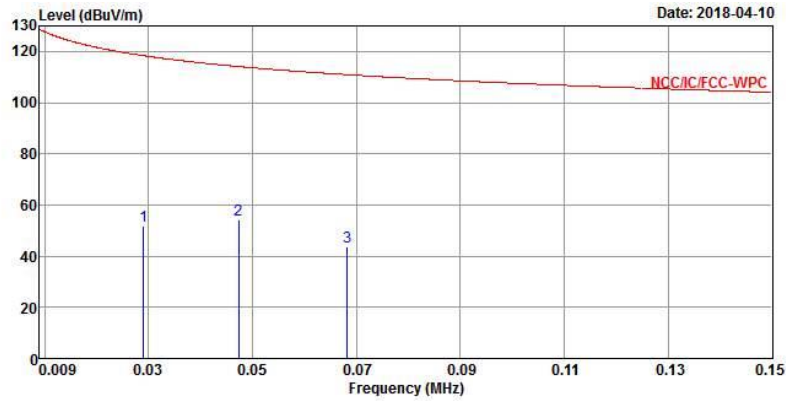

	Freq	Level	Over Limit	Limit Line	ReadAntenna Level	Antenna Factor	Cable Loss	Preamp Factor	Remark	A/Pos	T/Pos
	MHz	dBuV/m	dB	dBuV/m	dBuV	dB/m	dB	dB		cm	deg
1	0.02902	51.75	-66.60	118.35	29.69	21.99	0.07	0.00	Peak	100	0
2	0.04735	54.11	-59.99	114.10	32.82	21.22	0.07	0.00	Peak	100	0
3	0.06822	43.65	-67.28	110.93	22.63	20.95	0.07	0.00	Peak	100	0

Note 1: ">20dB" means spurious emission levels that exceed the level of 6 dB below the applicable limit.
 Note 2: "N/F" means Nothing Found spurious emissions (No spurious emissions were detected.)
 Note 3: Measurement worst emissions of receive antenna polarization: H(Horizontal).
 Note 4: No level of unwanted emissions exceeds the level of the fundamental emission.
 Note 5: Except fundamental emission, other emissions from digital circuitry used to control additional panel functions or display capabilities other than the touch panel radio transmission. While disable touch panel radio transmission, other emissions have the same levels. Therefore other emissions level could be exceed the fundamental emission level.



Transmitter Radiated Emissions (150 kHz – 30 MHz)

Modulation Mode	ASK	Polarization	H
Operating Mode	1	Operating Function	Wireless Charger

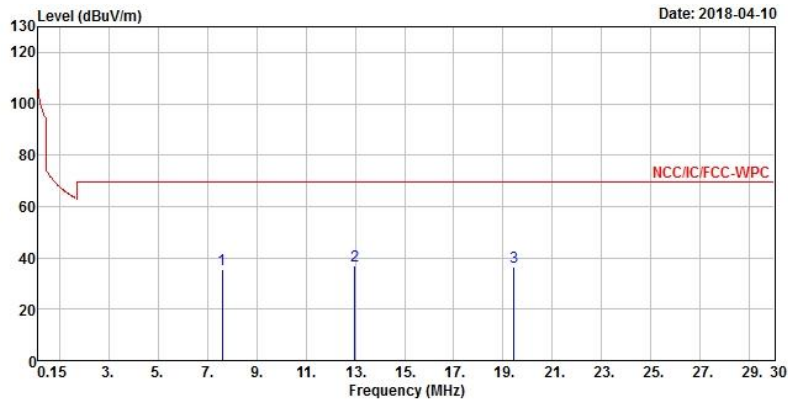

	Freq	Level	Over Limit	Limit Line	ReadAntenna Level	Antenna Factor	Cable Loss	Preamp Factor	Remark	A/Pos	T/Pos
	MHz	dBuV/m	dB	dBuV/m	dBuV	dB/m	dB	dB		cm	deg
1	7.61250	35.39	-34.15	69.54	13.75	21.12	0.52	0.00	Peak	100	360
2	12.98550	36.92	-32.62	69.54	14.48	21.77	0.67	0.00	Peak	100	360
3	19.43310	36.51	-33.03	69.54	13.35	22.35	0.81	0.00	Peak	100	360

Note 1: ">20dB" means spurious emission levels that exceed the level of 6 dB below the applicable limit.
 Note 2: "N/F" means Nothing Found spurious emissions (No spurious emissions were detected.)
 Note 3: Measurement worst emissions of receive antenna polarization: H(Horizontal).
 Note 4: No level of unwanted emissions exceeds the level of the fundamental emission.
 Note 5: Except fundamental emission, other emissions from digital circuitry used to control additional panel functions or display capabilities other than the touch panel radio transmission. While disable touch panel radio transmission, other emissions have the same levels. Therefore other emissions level could be exceed the fundamental emission level.

3.2.6 Transmitter Radiated Emissions (Above 30MHz)

Transmitter Radiated Emissions (Above 30MHz)			
Modulation Mode	ASK	Test Freq. (kHz)	110.90 kHz
Operating Mode	1	Polarization	V

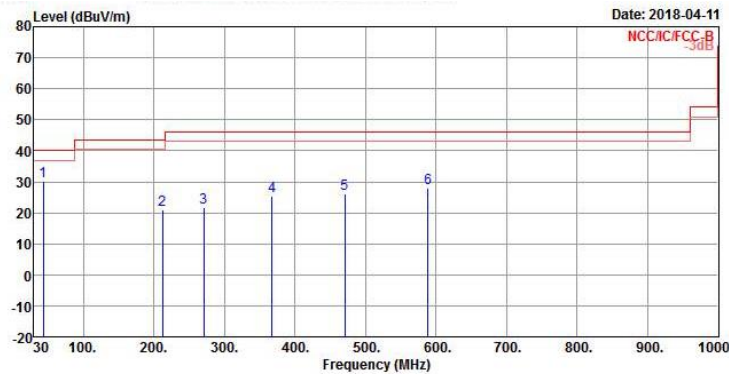

	Freq	Level	Over Limit	Limit Line	ReadAntenna Level	Cable Loss	Preamp Loss	Remark	A/Pos	T/Pos
	MHz	dBuV/m	dB	dBuV/m	dBuV	dB/m	dB	dB	cm	deg
1	43.58000	30.08	-9.92	40.00	39.98	15.82	1.83	27.55 Peak	100	360
2	212.36000	21.12	-22.38	43.50	31.13	14.28	2.59	26.88 Peak	100	360
3	270.56000	21.63	-24.37	46.00	27.85	18.02	2.51	26.75 Peak	100	360
4	367.56000	25.32	-20.68	46.00	29.59	19.82	3.00	27.09 Peak	100	360
5	470.38000	26.24	-19.76	46.00	28.06	22.38	3.47	27.67 Peak	100	360
6	588.72000	27.94	-18.06	46.00	28.58	23.62	3.71	27.97 Peak	100	360

Note 1: ">20dB" means spurious emission levels that exceed the level of 6 dB below the applicable limit.
 Note 2: "N/F" means Nothing Found spurious emissions (No spurious emissions were detected.)
 Note 3: Measurement receive antenna polarization: H (Horizontal), V (Vertical)
 Note 4: No level of unwanted emissions exceeds the level of the fundamental emission.
 Note 5: Except fundamental emission, other emissions from digital circuitry used to control additional panel functions or display capabilities other than the touch panel radio transmission. While disable touch panel radio transmission, other emissions have the same levels. Therefore other emissions level could be exceed the fundamental emission level.



Transmitter Radiated Emissions (Above 30MHz)			
Modulation Mode	ASK	Test Freq. (kHz)	110.90 kHz
Operating Mode	1	Polarization	H

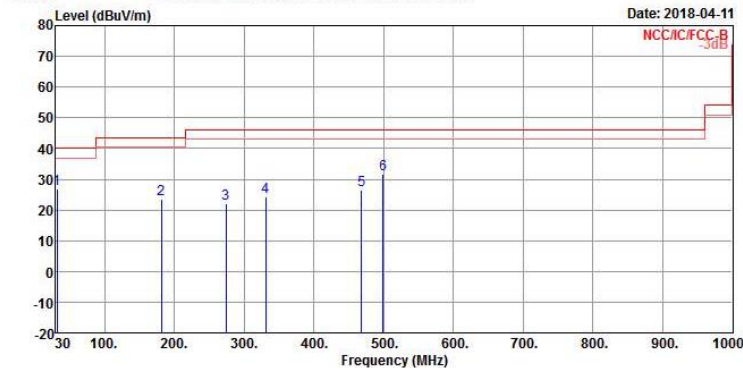

	Freq	Level	Over Limit	Limit Line	ReadAntenna Level	Antenna Factor	Cable Loss	Preamp Factor	Remark	A/Pos	T/Pos
	MHz	dBuV/m	dB	dBuV/m	dBuV	dB/m	dB	dB		cm	deg
1	31.94000	26.97	-13.03	40.00	30.54	22.27	1.74	27.58	Peak	100	0
2	181.32000	23.65	-19.85	43.50	34.13	14.28	2.24	27.00	Peak	100	0
3	274.44000	22.24	-23.76	46.00	28.37	18.01	2.60	26.74	Peak	100	0
4	330.70000	24.39	-21.61	46.00	29.66	18.85	2.75	26.87	Peak	100	0
5	468.44000	26.34	-19.66	46.00	28.21	22.32	3.47	27.66	Peak	100	0
6	499.48000	31.51	-14.49	46.00	33.25	22.55	3.54	27.83	Peak	100	0

Note 1: ">20dB" means spurious emission levels that exceed the level of 6 dB below the applicable limit.
 Note 2: "N/F" means Nothing Found spurious emissions (No spurious emissions were detected.)
 Note 3: Measurement receive antenna polarization: H (Horizontal), V (Vertical)
 Note 4: No level of unwanted emissions exceeds the level of the fundamental emission.
 Note 5: Except fundamental emission, other emissions from digital circuitry used to control additional panel functions or display capabilities other than the touch panel radio transmission. While disable touch panel radio transmission, other emissions have the same levels. Therefore other emissions level could be exceed the fundamental emission level.

3.3 Emission Bandwidth

3.3.1 Emission Bandwidth Limit

Emission Bandwidth Limit
N/A

3.3.2 Measuring Instruments

Refer a test equipment and calibration data table in this test report.

3.3.3 Test Procedures

Test Method
<input checked="" type="checkbox"/> For the emission bandwidth refer ANSI C63.10, clause 6.9.3 for occupied bandwidth testing.
<input checked="" type="checkbox"/> For radiated measurement. Loop antenna was rotated about the horizontal and vertical axis and the equipment to be measured and the test antenna shall be oriented to obtain the maximum emitted field strength level.

3.3.4 Test Setup

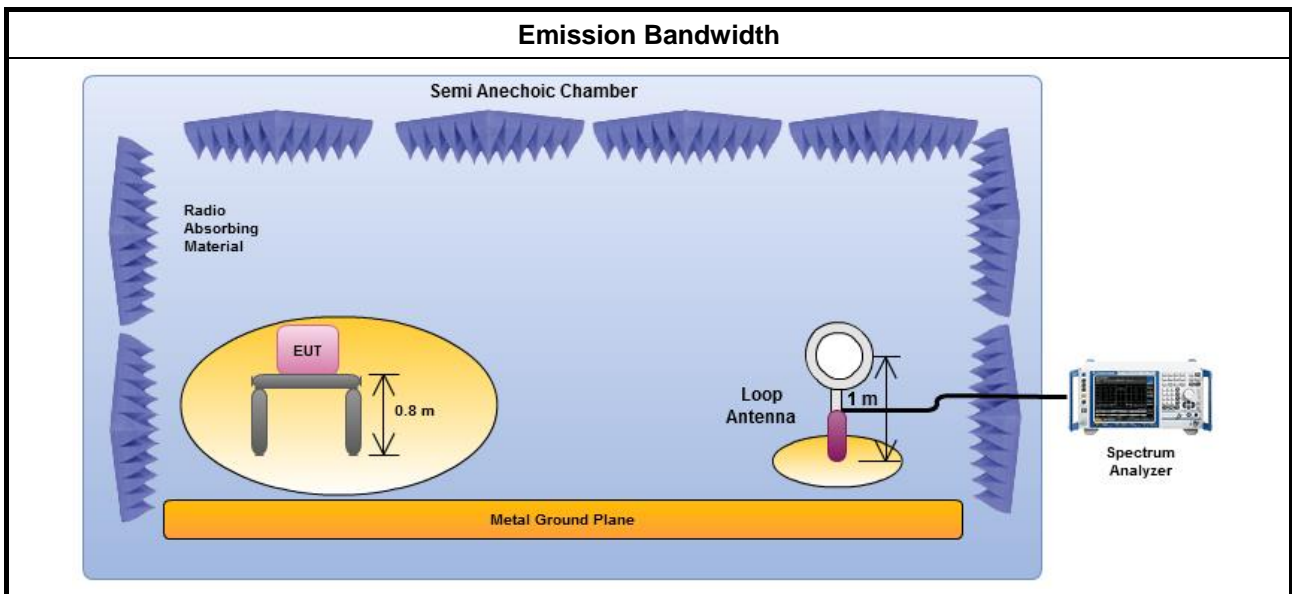

3.3.5 Test Result of Emission Bandwidth

Occupied Channel Bandwidth Result			
Modulation Mode	Frequency (kHz)	20dB Bandwidth (kHz)	99% Bandwidth (kHz)
ASK	110.90	0.25	0.21
Limit		N/A	N/A
Result		Complied	

Emission Bandwidth Plot 20dB Bandwidth (110.90kHz)

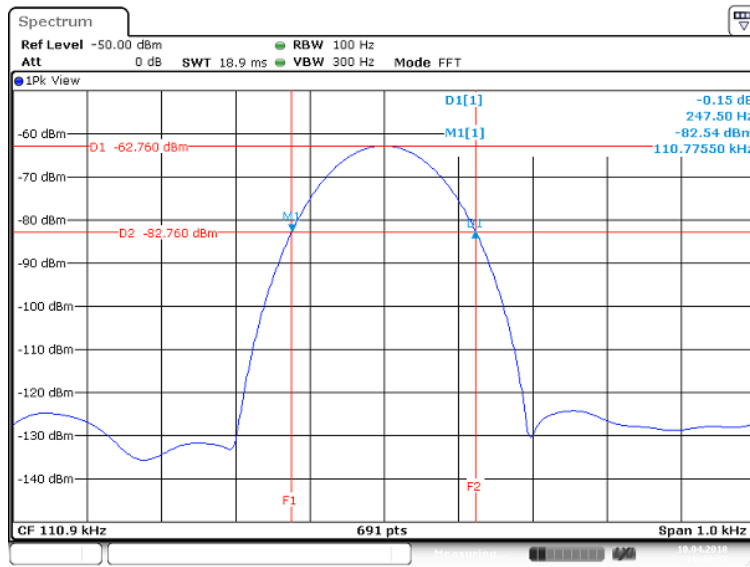

Date: 10.APR.2018 19:44:52

Emission Bandwidth Plot 99% Bandwidth (110.90 kHz)

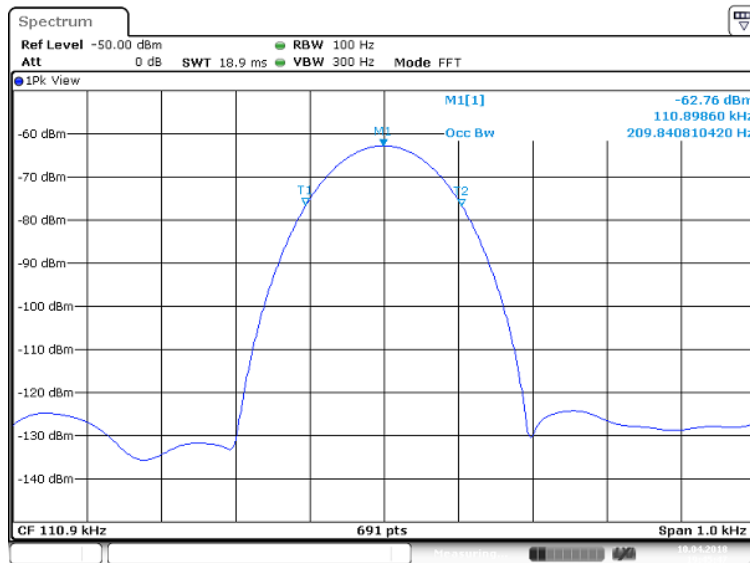

Date: 10.APR.2018 19:45:48



4 Test Equipment and Calibration Data

< Radiated Emission >

Instrument	Manufacturer	Model No.	Serial No.	Characteristics	Calibration Date	Calibration Due Date
3m Semi Anechoic Chamber	SIDT FRANKONIA	SAC-3M	03CH03-HY	30MHz ~ 1GHz 3m	31/Oct/2017	30/Oct/2018
Amplifier	HP	8447D	2944A08033	10kHz ~ 1.3GHz	19/Apr/2017	18/Apr/2018
Spectrum	R&S	FSV40	101500	9kHz ~ 40GHz	28/Jun/2017	27/Jun/2018
Receiver	R&S	ESR3	102052	9KHz ~ 3.6GHz	29/Apr/2017	28/Apr/2018
RF Cable-R03m	Jye Bao	RG142	CB021	9kHz ~ 1GHz	26/Jan/2018	25/Jan/2019
Bilog Antenna	SCHAFFNER	CBL 6112B	22237	30MHz ~ 1GHz	08/Jul/2017	07/Jul/2018
Loop Antenna	TESEQ	HLA 6120	31244	9 kHz~30 MHz	16/Mar/2018	15/Mar/2019