

2. User Manual

2.1 FOB KEY

-LF : Find and recognize FOB inside the vehicle or near the door handle through LF search

-IMMO: Determining the existence of a short-range FOB through IMMO communication when LF search is not recognized

-RKE: Receiving RKE signal from a long distance outside the vehicle through RF communication

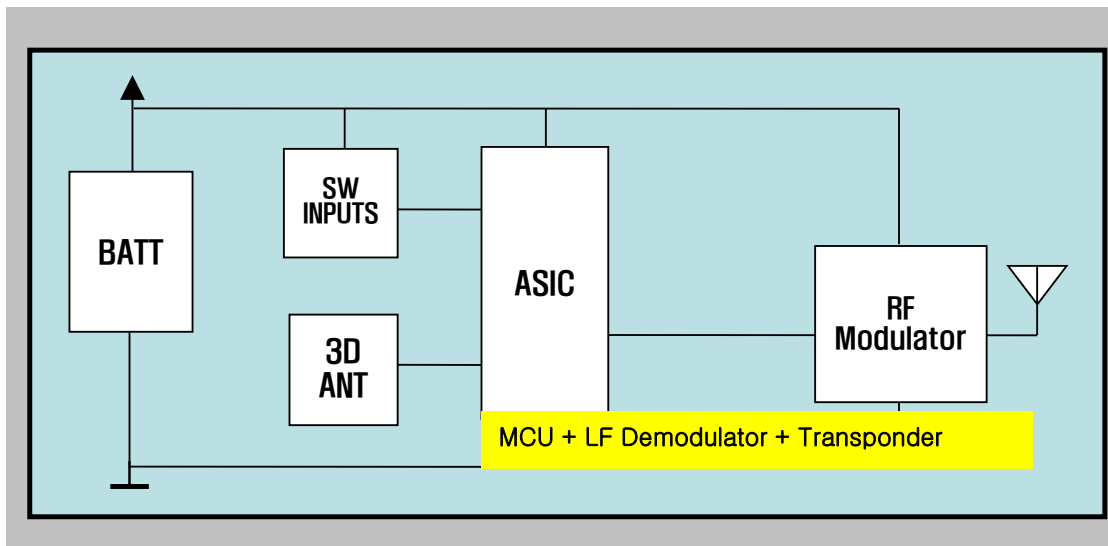

2.2 Immobilizer & Knob SW

-FOB KEY has TP for manual start through emergency authentication.

-Knob SW is a button to control engine START.

- It has a TP coil to take action in emergency situations.

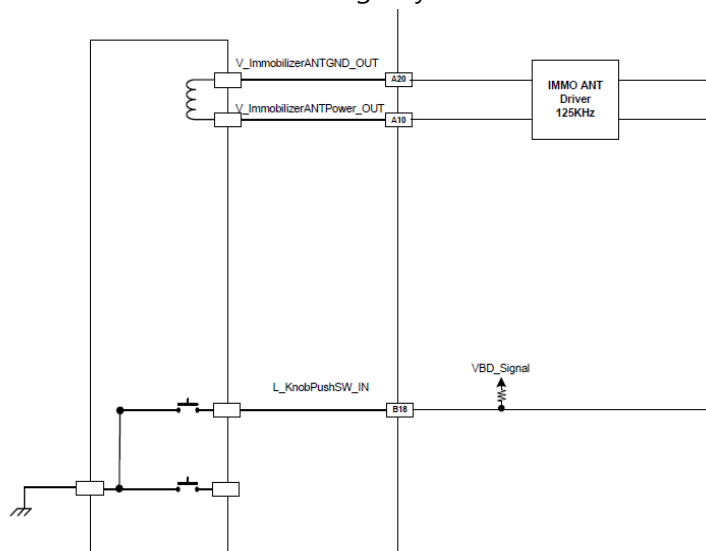

FCC warning statement:

15.19

λ. This device complies with Part 15 of the FCC Rules. Operation is subject to the following two conditions: (1) this device may not cause harmful interference, and (2) this device must accept any interference received, including interference that may cause undesired operation.

15.105

This equipment has been tested and found to comply with the limits for a Class B digital device, pursuant to part 15 of the FCC Rules. These limits are designed to provide reasonable protection against harmful interference in a residential installation. This equipment generates, uses and can radiate radio frequency energy and, if not installed and used in accordance with the instructions, may cause harmful interference to radio communications.

However, there is no guarantee that interference will not occur in a particular installation. If this equipment does cause harmful interference to radio or television reception, which can be determined by turning the equipment

off and on, the user is encouraged to try to correct the interference by one or more of the following measures:

- Reorient or relocate the receiving antenna.
- Increase the separation between the equipment and receiver.
- Connect the equipment into an outlet on a circuit different from that to which the receiver is connected.
- Consult the dealer or an experienced radio/TV technician for help.

15.21

- Any changes or modifications not expressly approved by the party responsible for compliance could void the authority to operate equipment.

- This device and its antenna must not be co-located or operating in conjunction with any other antenna or transmitter.

- End-users and installers must be provided with antenna installation instructions and transmitter operating conditions for satisfying RF exposure compliance.

FCC/ IC RF Radiation Exposure Statement:

This equipment complies with FCC/ISED radiation exposure limits set forth for an uncontrolled environment. This equipment should be installed and operated with minimum distance 15cm between the radiator & your body.

This device complies with FCC/ ISED radiation exposure limits set forth for an uncontrolled environment.

IC warning statement:

RSS-Gen Issue 4 8.4

This device complies with Industry Canada's licence-exempt RSSs. Operation is subject to the following two conditions: (1) This device may not cause interference; and (2) This device must accept any interference, including interference that may cause undesired operation of the device.

Le présent appareil est conforme aux CNR d'Industrie Canada applicables aux appareils radio exempts de licence.

L'exploitation est autorisée aux deux conditions suivantes: (1) l'appareil ne doit pas produire de brouillage, et (2)

l'utilisateur de l'appareil doit accepter tout brouillage radioélectrique subi, même si le brouillage est susceptible d'en compromettre le fonctionnement.

Industry Canada ICES-003 Compliance Label:

CAN ICES-3

Co-located

This device and its antenna(s) must not be co-located or operating in conjunction with any other antenna or transmitter.