

Straubing, 16 January 2003

TEST - REPORT

No. 51905-20108

for

MOBY E MIFARE SLG 75

Inductive Tag Reader

Applicant: Siemens AG, Fürth

Purpose of testing: To show compliance with

FCC Code of Federal Regulations,
CFR 47, Part 15, Subpart C,
Section 15.225

Note:

The test data of this report relate only to the individual item which has been tested. This report shall not be reproduced except in full extent without the written approval of the testing laboratory.

Table of Contents

1.	Administrative Data	3
2.	Identification of Test Laboratory	4
3.	Summary of Test Results	5
4.	Operation Mode of EUT.....	6
5.	Configuration of EUT and Peripheral Devices	7
6.	Measuring Methods	8
6.1.	Field strength of in-band emissions (§15.225 (a)) and unwanted emissions < 30 MHz (§15.225 (b))	8
6.2.	Frequency tolerance (§15.225 (c)).....	9
6.3.	Unwanted Emission 30 MHz - 1 GHz (§15.225 (b))	11
7.	Photographs of Test Setups	13
7.1.	Radiated Emissions 10 kHz – 30 MHz (10 m test distance)	14
7.2.	Radiated Emissions 10 kHz – 1000 MHz (prescan)	15
7.3.	Radiated Emissions 30 – 1000 MHz (final test).....	17
	Radiated Emissions 30 – 1000 MHz (final test) - continued	18
8.	Equipment List.....	19
9.	Referenced Regulations	21
10.	List of Measurements	22
11.	Test Results	23
12.	Charts taken during testing.....	31

1. Administrative Data

Equipment Under Test (EUT): MOBY E MIFARE SLG 75
Serial number(s): Sample no. 1
Type of equipment: Inductive Tag Reader
Type of emission: 7K0A1D
Parts/accessories: ---
FCC-ID: NXWMOBYE-SLG75

Applicant: Siemens AG, Fürth
Würzburger Str. 121
D-90766 Fürth

Contract identification: ---

Contact person: Mr. Horst

Manufacturer: Siemens AG, Fürth

Receipt of EUT: 01 July 2002

Dates of test: July 2002 to January 2003

Note: ---

Responsible for testing: Thomas Eberl

Responsible for test report: Thomas Eberl

2. Identification of Test Laboratory

Test Laboratory: Senton GmbH EMI/EMC Test Center
(full address): Aeussere Fruehlingstrasse 45
D-94315 Straubing
Germany

Contact person: Mr. Johann Roidt
Communication: Telephone (+49) 0 94 21 / 55 22-0
Fax (+49) 0 94 21 / 55 22-99
eMail: Office@senton.de

FCC registration number: 90926
Industry Canada file number: IC 3050

3. Summary of Test Results

The tested sample complies with the requirements for set forth in the

The Code of Federal Regulations 47, Part 15, Subpart C, Section 15.225

of the Federal Communication Commission (FCC).



Johann Roidt
Technical Manager

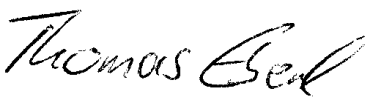

Thomas Eberl
Test Engineer

4. Operation Mode of EUT

Continuously reading a TAG

5. Configuration of EUT and Peripheral Devices

Configuration of cables of EUT

Not applicable

Configuration of peripheral devices connected to EUT

The EUT was connected to a Fujitsu Notebook PC via standard RS 232 interface.

6. Measuring Methods

6.1. Field strength of in-band emissions (§15.225 (a)) and unwanted emissions < 30 MHz (§15.225 (b))

Radiated emissions in the frequency range 9 kHz – 30 MHz will be measured initially at a distance of 3 meters. A prescan at 3 meter distance will be performed in a shielded room with the detector of the spectrum analyzer or EMI Receiver set to peak. Final measurement is then performed at 30 meter distance. In case the regulation requires testing at other distances, the result will be extrapolated. The extrapolation factor will be determined by making a second measurement at 10 meter distance. The provisions of 15.31 (d) apply.

According to section 15.209 (d) final measurement is performed with the detector set to Quasi Peak except for the frequency bands 9 – 90 kHz and 110 – 490 kHz where average detector is employed.

6.2. Frequency tolerance (§15.225 (c))

6.2.1. Frequency stability vs. temperature

The frequency stability vs. temperature was measured with a spectrum analyzer connected to the output of the transmitter power amplifier (conducted measurement) via dummy load while EUT was operating in transmit mode using the assigned frequency.

The trace mode of the spectrum analyzer was set to write with frequency count mode activated:

RBW = 100 Hz, VBW = 100 Hz, span = 20 kHz, sweep = 1.5 s (auto mode)

See figure 1 for the measurement setup.

Test equipment used (see equipment list for details):
 02, 18, 51, 54, 69, 70, 71

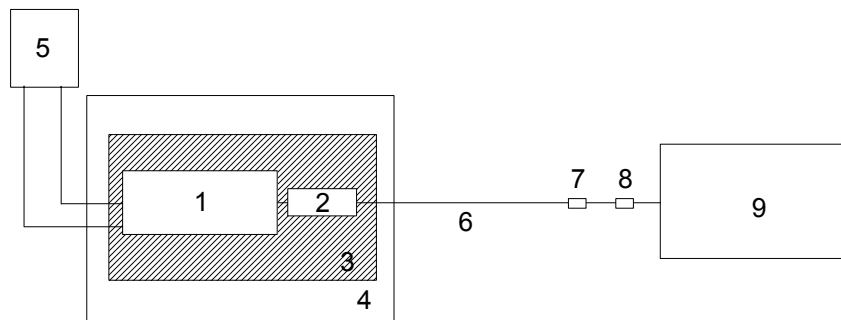

Figure 1: Measurement setup for testing within temperature test chamber

- | | |
|----------------------------|---------------------|
| 1 Transmitter (EUT) | 6 Test cable |
| 2 Probe antenna | 7 DC-block |
| 3 Wooden support | 8 Attenuator |
| 4 Temperature test chamber | 9 Spectrum analyzer |
| 5 DC power supply | |

6.2.2. Frequency stability vs. supply voltage

The frequency stability vs. supply voltage was measured with a spectrum analyzer connected to the output of the transmitter power amplifier (conducted measurement) via dummy load while EUT was operating in transmit mode using the assigned frequency.

The trace mode of the spectrum analyzer was set to write with frequency count mode activated:

RBW = 100 Hz, VBW = 100 Hz, span = 20 kHz, sweep = 1.5 s (auto mode)

See figure 1 for the measurement setup.

Test equipment used (see equipment list for details):
02, 18, 51, 69, 70, 71

6.3. Unwanted Emission 30 MHz - 1 GHz (§15.225 (b))

Radiated emissions were measured over the frequency range from 30 MHz to 1 GHz. For final testing the detector-function of the spectrum analyzer was set to quasi peak

Measurements were made in both the horizontal and vertical planes of polarization. Preliminary scans were taken in a semi-anechoic room using a spectrum analyzer with the detector function set to peak and resolution bandwidth set to 100 kHz. All tests were performed at a test-distance of 3 meters. Hand-held or body-worn devices are rotated through three orthogonal axes to determine which attitude and configuration produces the highest emission relative to the limit and therefore shall be used for final testing. For final testing an open-area test-site was used. During the tests the EUT was rotated all around and the receiving-antenna was raised and lowered from 1 meter to 4 meters to find the maximum levels of emissions. The cables and equipment were placed and moved within the range of position likely to find their maximum emissions.

See figure 2 for the measurement setup.

Test equipment used (see equipment list for details):
01, 06, 12, 15, 38, 39, 40, 41, 55, 58, 61, 64, 66

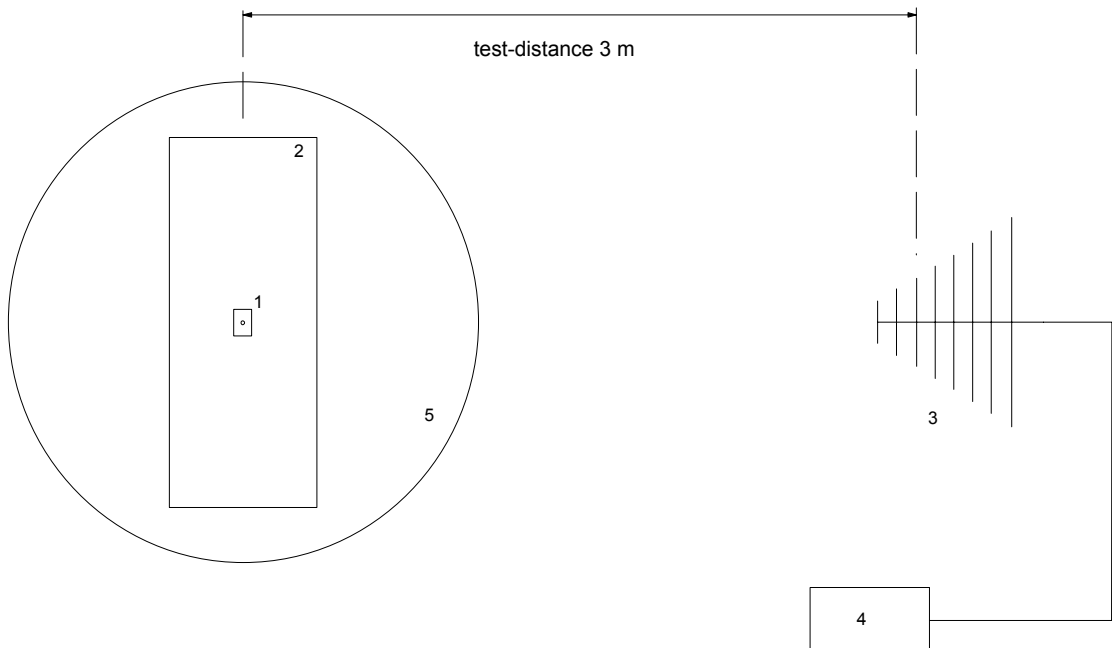

Figure 2: Measurement setup for radiated emission test

- 1 Transmitter (EUT)
- 2 Wooden table

- 3 Measurement antenna
- 4 Test receiver
- 5 Turn table

7. Photographs of Test Setups

7.1. Radiated Emissions 10 kHz – 30 MHz (10 m test distance)



7.2. Radiated Emissions 10 kHz – 1000 MHz (prescan)

ANT 1



ANT 12



Radiated Emissions 10 kHz – 1000 MHz (prescan) - continued

ANT 18



ANT 30



7.3. Radiated Emissions 30 – 1000 MHz (final test)



Radiated Emissions 30 – 1000 MHz (final test) - continued

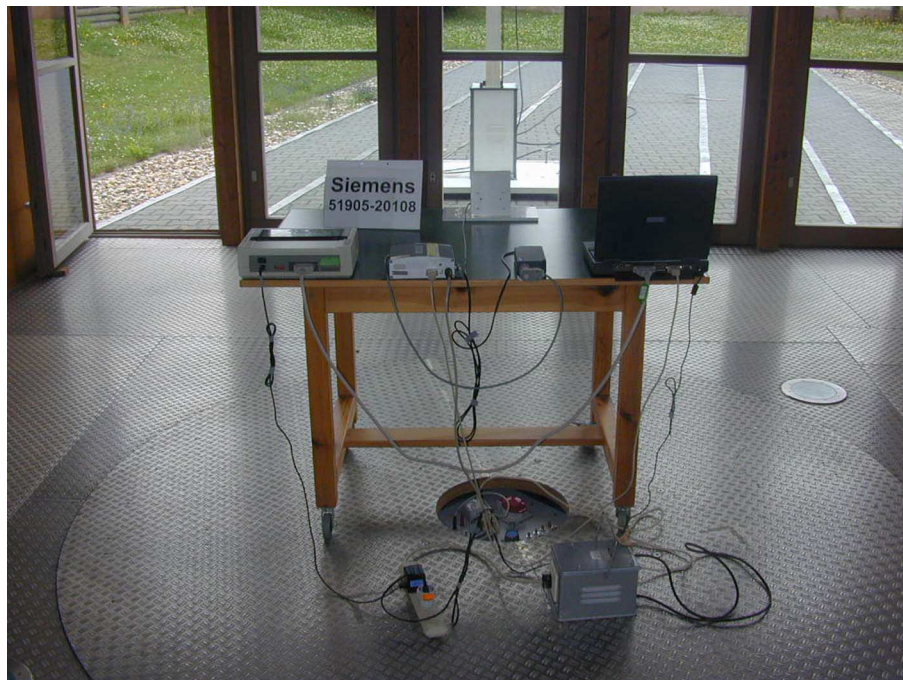

8. Equipment List

To facilitate reference to test equipment used for related tests, each item of test equipment and ancillaries such as cables are identified (numbered) by the Test Laboratory.

No.	Type	Model	Serial Number	Manufacturer
01	Spectrum Analyzer	R 3271	05050023	Advantest
02	EMI Test Receiver	ESMI	839379/013 839587/006	Rohde & Schwarz
03	Test Receiver	ESH 3	880112/032	Rohde & Schwarz
04	Test Receiver	ESHS 10	860043/016	Rohde & Schwarz
05	Test Receiver	ESV	881414/009	Rohde & Schwarz
06	Test Receiver	ESVP	881120/024	Rohde & Schwarz
07	Audio Analyzer	UPA	862954	Rohde & Schwarz
08	Power Meter	NRVS	836856/015	Rohde & Schwarz
09	Power Sensor	NRV-Z52	837901/030	Rohde & Schwarz
10	Power Sensor	NRV-Z4	863828/015	Rohde & Schwarz
11	Preamplifier	ESV-Z3	860907/004	Rohde & Schwarz
12	Preamplifier	R14601		Advantest
13	Preamplifier	ACX/080-3030	32640	CTT
14	Preamplifier	ACO/180-3530	32641	CTT
15	Signal generator	SMY 01	830694/001	Rohde & Schwarz
16	Signal Generator	HP 8673 D	2930A00966	Hewlett Packard
17	Waveform Generator	HP 33120 A	US34005375	Hewlett Packard
18	Attenuator 20 dB	4776-20	9503	Narda
19	Attenuator 10 dB	4776-10	9412	Narda
20	Pulse Limiter	ESH 3-Z2	1144	Rohde & Schwarz
21	Pulse Limiter	11947 A	3107A00566	Hewlett Packard
22	V-Network	ESH 3-Z5	862770/018	Rohde & Schwarz
23	V-Network	ESH 3-Z5	894785/005	Rohde & Schwarz
24	V-Network	ESH 3-Z5	830952/025	Rohde & Schwarz
25	V-Network	ESH 3-Z6	830722/010	Rohde & Schwarz
26	V-Network	NSLK 8127	8127152	Schwarzbeck
27	V-Network	NNLA 8119	8119148	Schwarzbeck
28	V-Network	SE 01	01	Senton
29	T-Network	ESH 3-Z4	890602/011	Rohde & Schwarz
30	T-Network	ESH 3-Z4	890602/012	Rohde & Schwarz
31	High Impedance Probe	TK 9416	01	Schwarzbeck
32	High Impedance Probe	TK 9416	02	Schwarzbeck
33	Current Probe	ESH 2-Z1	863366/18	Rohde & Schwarz
34	Current Probe	ESV-Z1	862553/3	Rohde & Schwarz

No.	Type	Model	Serial Number	Manufacturer
35	Absorbing Clamp	MDS 21	80911	Lüthi
36	Absorbing Clamp	MDS 21	79690	Lüthi
37	Loop Antenna	HFH2-Z2	882964/1	Rohde & Schwarz
38	Biconical Antenna	HK 116	842204/001	Rohde & Schwarz
39	Biconical Antenna	HK 116	836239/02	Rohde & Schwarz
40	Log. Periodic Antenna	HL 223	841516/023	Rohde & Schwarz
41	Log. Periodic Antenna	HL 223	834408/12	Rohde & Schwarz
42	Horn Antenna	3115	9508-4553	Emco
43	Horn Antenna	3160-03	9112-1003	Emco
44	Horn Antenna	3160-04	9112-1001	Emco
45	Horn Antenna	3160-05	9112-1001	Emco
46	Horn Antenna	3160-06	9112-1001	Emco
47	Horn Antenna	3160-07	9112-1008	Emco
48	Horn Antenna	3160-08	9112-1002	Emco
49	Horn Antenna	3160-09	9403-1025	Emco
50	Digital multimeter	199	463386	Keithley
51	DC Power Supply	NGSM 32/10	203	Rohde & Schwarz
52	DC Power Supply	NGB	2455	Rohde & Schwarz
53	DC Power Supply	NGA	386	Rohde & Schwarz
54	Temperature Test Chamber	HT4010	07065550	Heraeus
55	Cable	RG214	1309	Senton
56	Cable	200CM_001	1357	Rosenberger
57	Cable	150CM_001	1479	Rosenberger
58	Cable Set EG1	RG214	1189 - 1191	Senton
59	Cable Set Cabine 1	RG214		Senton
60	Cable Set Cabine 2	RG214		Senton
61	Cable Set Cabine 3	RG214		Senton
62	Shielded Room	No. 1	1451	Senton
63	Shielded Room	No. 2	1452	Senton
64	Semi-anechoic Chamber	No. 3	1453	Siemens
65	Shielded Room	No. 4	1454	Euroshield
66	Open Area Test Site	EG 1		Senton
67	Cable for Antenna Connector			Lucent Technologies
68	DC Block 0.01-18GHz		8037	Inmet Corp.
69	High pass filter			Lucent Technologies
69	DC Block	7006	A2798	Weinschel Corp.
70	Cable for Antenna Connector			Senton
71	Dummy load			Futaba Corporation

9. Referenced Regulations

All tests were performed with reference to the following regulations and standards:

<input checked="" type="checkbox"/>	CFR 47 Part 2	Code of Federal Regulations Part 2 (Frequency Allocations And Radio Treaty Matters, General Rules And Regulations) of the Federal Communication Commission (FCC)	October 1, 1999
<input type="checkbox"/>	CFR 47 Part 15 Subpart A	Code of Federal Regulations Part 15 (Radio Frequency Devices), Subpart A (General) of the Federal Communication Commission (FCC)	May 2002
<input type="checkbox"/>	CFR 47 Part 15 Subpart B	Code of Federal Regulations Part 15 (Radio Frequency Devices), Subpart B (Unintentional Radiators) of the Federal Communication Commission (FCC)	May 2002
<input checked="" type="checkbox"/>	CFR 47 Part 15 Subpart C	Code of Federal Regulations Part 15 (Radio Frequency Devices), Subpart C (Intentional Radiators) of the Federal Communication Commission (FCC)	May 2002
<input type="checkbox"/>	CFR 47 Part 95 Subpart C/E	Code of Federal Regulations Part 95 (Personal Radio Services), Subpart C/E (Radio Control(R/C) Radio Service) of the Federal Communication Commission (FCC)	October 1, 1998
<input checked="" type="checkbox"/>	ANSI C63.4	American National Standard for Methods of Measurement of Radio-Noise Emissions from Low-Voltage Electrical and Electronic Equipment in the Range of 9 kHz - 40 GHz	October 1992
<input checked="" type="checkbox"/>	RSS-210	Radio Standards Specification RSS-210 Issue 5 for Low Power Licence-Exempt Radiocommunication Devices of Industry Canada	November 2001
<input type="checkbox"/>	TIA/EIA-603	Land Mobile FM or PM Communications Equipment Measurement and Performance Standards	February 1993
<input type="checkbox"/>	TIA/EIA-603-1	Addendum to TIA/EIA-603	March 4, 1998

10. List of Measurements

CFR 47 Part 15 Subpart C			
Section(s):	Test	Page	Result
§15.207	Conducted powerline emissions		Not Applicable
§15.225 (a)	Maximum in-band field strength		Passed
§15.225 (b)	Out-of-band emissions		Passed
§15.225 (c)	Frequency tolerance of carrier signal		Passed

11. Test Results

**Field Strength of Emissions according to FCC Rules,
 Part 15, Subpart C, Section 15.225 (a), (b)
 Frequency Band < 30 MHz**

Model: **MOBY E MIFARE SLG75**
 Type: **Inductive Reader (ANT 1)**
 Serial No. **Prototype 1**
 Applicant: **Siemens AG, Fürth**
 Test Site: **Open Field Test Site (without Ground Plane)**
 Distance: **10 Meter**
 Date of Test: **16 July 2002**

Frequency (MHz)	Detector	Antenna Polariz.	Analyzer Reading (dBµV) 10m	Corr. Factor (dB)	Field Strength (dBµV/m) 10m	Field Strength (dBµV/m) 30m	Limit dBµV/m	Margin dB
13.553	Q.P.	N/A	***	20			29.5	---
13.560	Q.P.	N/A	43.0	20	63.0	43.0	80.0	37.0
13.567	Q.P.	N/A	***	20			29.5	---
27.125	Q.P.	N/A	***	20			29.5	---

*** = No emissions above noise floor detected

Sample calculation of field strength values:

$$\text{Field Strength (dB}\mu\text{V/m)} = \text{Analyzer Reading (dB}\mu\text{V)} + \text{Correction Factor (dB)}$$

Test equipment used (see equipment list for details):
 02, 13, 14, 16, 38, 40, 42, 57, 64, 67

**Field Strength of Emissions according to FCC Rules,
 Part 15, Subpart C, Section 15.225 (a), (b)
 Frequency Band < 30 MHz**

Model: **MOBY E MIFARE SLG75**
 Type: **Inductive Reader (ANT 12)**
 Serial No.: **Prototype 1**
 Applicant: **Siemens AG, Fürth**
 Test Site: **Open Field Test Site (without Ground Plane)**
 Distance: **10 Meter**
 Date of Test: **16 July 2002**

Frequency (MHz)	Detector	Antenna Polarization	Analyzer Reading (dBµV) 10m	Correction Factor (dB)	Field Strength (dBµV/m) 10m	Field Strength (dBµV/m) 30m	Limit dBµV/m	Margin dB
13.553	Q.P.	N/A	***	20			29.5	---
13.560	Q.P.	N/A	32.5	20	52.5	32.5	80.0	47.5
13.567	Q.P.	N/A	***	20			29.5	---
27.125	Q.P.	N/A	***	20			29.5	---

*** = No emissions above noise floor detected

Sample calculation of field strength values:

$$\text{Field Strength (dB}\mu\text{V/m)} = \text{Analyzer Reading (dB}\mu\text{V)} + \text{Correction Factor (dB)}$$

Test equipment used (see equipment list for details):
 02, 13, 14, 16, 38, 40, 42, 57, 64, 67

**Field Strength of Emissions according to FCC Rules,
 Part 15, Subpart C, Section 15.225 (a), (b)
 Frequency Band < 30 MHz**

Model: **MOBY E MIFARE SLG75**
 Type: **Inductive Reader (ANT 18)**
 Serial No. **Prototype 1**
 Applicant: **Siemens AG, Fürth**
 Test Site: **Open Field Test Site (without Ground Plane)**
 Distance: **10 Meter**
 Date of Test: **16 July 2002**

Frequency (MHz)	Detector	Antenna Polariz.	Analyzer Reading (dBµV) 10m	Corr. Factor (dB)	Field Strength (dBµV/m) 10m	Field Strength (dBµV/m) 30m	Limit dBµV/m	Margin dB
13.553	Q.P.	N/A	***	20			29.5	---
13.560	Q.P.	N/A	44.0	20	64.0	44.0	80.0	36.0
13.567	Q.P.	N/A	***	20			29.5	---
27.125	Q.P.	N/A	***	20			29.5	---

*** = No emissions above noise floor detected

Sample calculation of field strength values:

$$\text{Field Strength (dB}\mu\text{V/m)} = \text{Analyzer Reading (dB}\mu\text{V)} + \text{Correction Factor (dB)}$$

Test equipment used (see equipment list for details):
 02, 13, 14, 16, 38, 40, 42, 57, 64, 67

**Field Strength of Emissions according to FCC Rules,
 Part 15, Subpart C, Section 15.225 (a), (b)
 Frequency Band < 30 MHz**

Model: **MOBY E MIFARE SLG75**
 Type: **Inductive Reader (ANT 30)**
 Serial No. **Prototype 1**
 Applicant: **Siemens AG, Fürth**
 Test Site: **Open Field Test Site (without Ground Plane)**
 Distance: **10 Meter**
 Date of Test: **16 July 2002**

Frequency (MHz)	Detector	Antenna Polariz.	Analyzer Reading (dBµV) 10m	Correction Factor (dB)	Field Strength (dBµV/m) 10m	Field Strength (dBµV/m) 30m	Limit dBµV/m	Margin dB
13.553	Q.P.	N/A	***	20			29.5	---
13.560	Q.P.	N/A	48.5	20	68.5	48.5	80.0	31.5
13.567	Q.P.	N/A	***	20			29.5	---
27.125	Q.P.	N/A	***	20			29.5	---

*** = No emissions above noise floor detected

Sample calculation of field strength values:

$$\text{Field Strength (dBµV/m)} = \text{Analyzer Reading (dBµV)} + \text{Correction Factor (dB)}$$

Test equipment used (see equipment list for details):
 02, 13, 14, 16, 38, 40, 42, 57, 64, 67

**Field Strength of Emissions according to FCC Rules,
 Part 15, Subpart C, Section 15.225 (b)
 Frequency Band > 30 MHz**

Model: **MOBY E MIFARE SLG 75**
 Type: **Inductive Reader**
 Serial No. **Prototype 1**
 Applicant: **Siemens AG, Fürth**
 Test Site: **Open Field Test Site**
 Distance: **3 Meter**
 Date of Test: **15 July 2002**

Frequency (MHz)	Detector	Antenna Polariz.	Analyzer Reading (dBµV) 10m	Correction Factor (dB)	Field Strength (dBµV/m) 10m	Limit dBµV/m	Margin dB
40.67	Q.P.	V	26.0	13.0	39.0	40.0	1
54.23	Q.P.	V	25.7	11.4	37.1	40.0	2.9
67.79	Q.P.	V	20.0	11.1	31.1	40.0	8.9
122.03	Q.P.	V	12.3	14.8	27.1	43.5	16.4
154.80	Q.P.	H	12.5	16.5	29.0	43.5	14.5
189.80	Q.P.	H	20.0	18.9	38.9	43.5	4.6
213.80	Q.P.	H	12.5	19.8	32.3	43.5	11.2
443.60	Q.P.	H	14.5	23.8	38.3	46.0	7.7
506.60	Q.P.	V	11.5	25.2	36.7	46.0	9.3
697.00	Q.P.	V	10.5	31.4	41.9	46.0	4.1

*** = No emissions above noise floor detected

Sample calculation of field strength values:

$$\text{Field Strength (dB}\mu\text{V/m)} = \text{Analyzer Reading (dB}\mu\text{V)} + \text{Correction Factor (dB)}$$

Test equipment used (see equipment list for details):
 02, 13, 14, 16, 38, 40, 42, 57, 64, 67

FREQUENCY STABILITY VS. TEMPERATURE

Section 15.225 (c)

Model: **MOBY E MIFARE SLG 75**
 Type: **Inductive Reader**
 Serial No. **Prototype 1**
 Applicant: **Siemens AG, Fürth**
 Date of Test: **16 July 2002**

Test conditions:

Temperature: see table below
 Supply voltage: 24.0 V DC

Specifications:

Frequency tolerance: **±0.01 % of nominal carrier frequency**
 Temperature range: -20 to +50°C

Temperature (°C)	Nominal carrier frequency (MHz)	Frequency measured (MHz)	Frequency deviation (Hz)	Frequency deviation (%)	Limit (%)
-20	13.560000	13.559860	-140	-0.0010	0.01
-10	13.560000	13.559850	-150	-0.0011	0.00
±0	13.560000	13.559590	-410	-0.0030	0.01
+10	13.560000	13.559840	-160	-0.0012	0.01
+20	13.560000	13.559910	-90	-0.0007	0.01
+30	13.560000	13.559820	-180	-0.0013	0.01
+40	13.560000	13.559820	-180	-0.0013	0.01
+50	13.560000	13.55981	-190	-0.0014	0.01

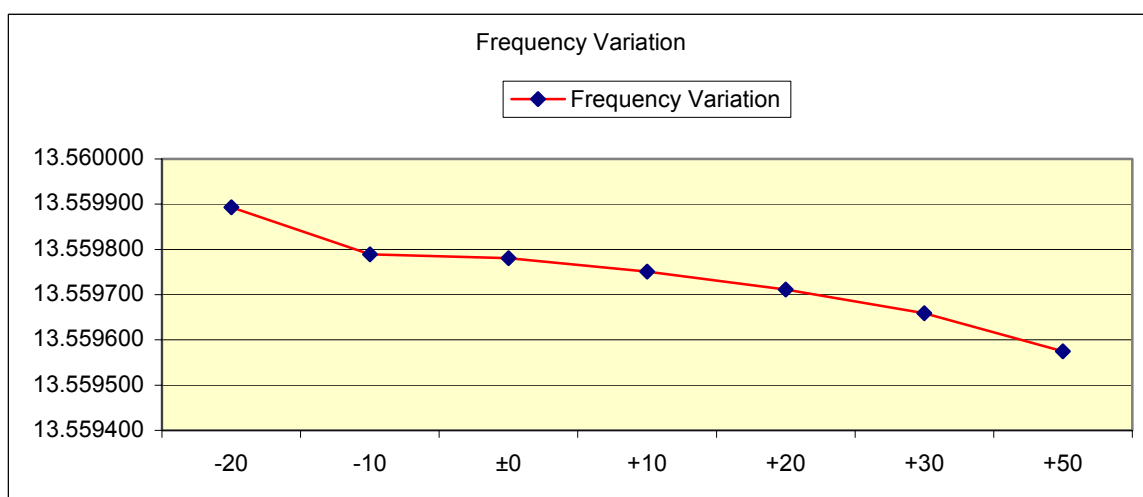

Result: Test passed

FREQUENCY STABILITY VS. SUPPLY VOLTAGE

Section 15.225 (c)

Model: **MOBY E MIFARE SLG 75**
 Type: **Inductive Reader**
 Serial No. **Prototype 1**
 Applicant: **Siemens AG, Fürth**
 Date of Test: **16 July 2002**

Test conditions:

Temperature: see table below
 Supply voltage: **24.0 V AC**

Specifications:

Frequency tolerance: **±0.01 % of nominal carrier frequency**
 Supply voltage range: **+/- 15 % of nominal supply voltage**

Supply voltage (V)	Nominal carrier frequency (MHz)	Frequency measured (MHz)	Frequency deviation (Hz)	Frequency deviation (%)	Limit (%)
20.40	13.560000	13.559901	-99	-0.00073	0.01
24.00	13.560000	13.559901	-99	-0.00073	0.01
27.60	13.560000	13.559901	-99	-0.00073	0.01

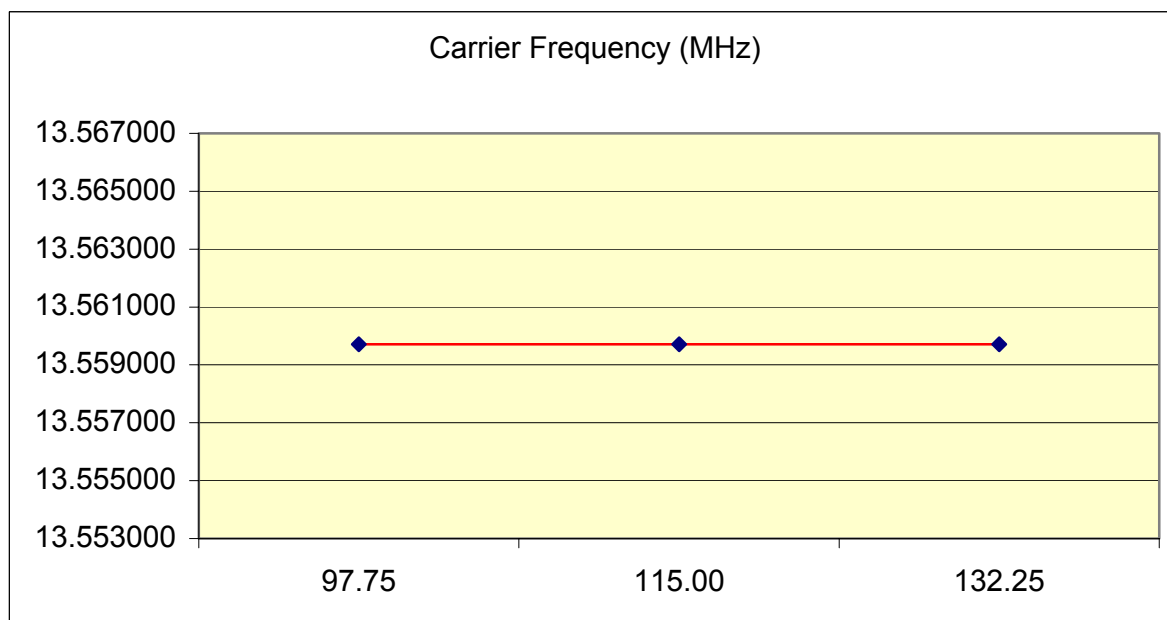

Result: Test passed

12. Charts taken during testing

Radiated Emission Test 9 kHz - 30 MHz according to FCC Part 15 Subpart C

Model: Moby E MIFARE SLG 75	
Serial no.: --	
Applicant: Siemens AG, Fürth, A&D SE RD 12	
Test site: Shielded room, cabin no. 3	
Tested on: Test distance 3 metres Antenna orthogonal to EUT	
Date of test: 02/25/2002	Operator: T. Eberl
Test performed: automatically	File name:

Mode:	
- FCC test setup	
- TX mode	
- with antenna : ANT 1	
- with TAG	

Detector: Peak / Final Results: QP	
---------------------------------------	--

Final results: 20 dB Margin	8 Subranges
--------------------------------	-------------

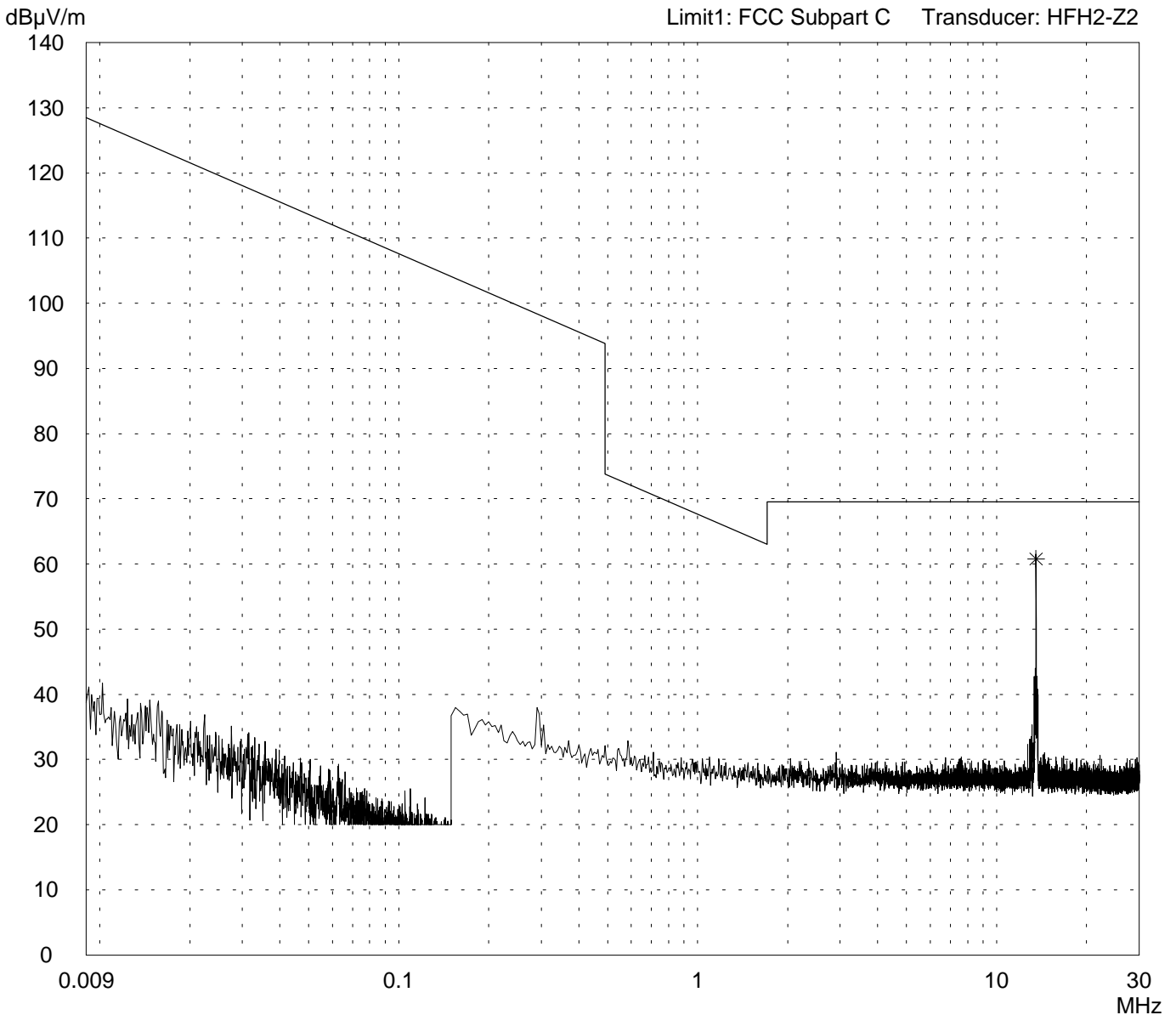

Result: Prescan

Project file: 51905-20108	Page of Pages
------------------------------	---------------

Radiated Emission Test 9 kHz - 30 MHz according to FCC Part 15 Subpart C

Model: Moby E MIFARE SLG 75	
Serial no.: --	
Applicant: Siemens AG, Fürth, A&D SE RD 12	
Test site: Shielded room, cabin no. 3	
Tested on: Test distance 3 metres Antenna orthogonal to EUT	
Date of test: 02/25/2002	Operator: T. Eberl
Test performed: automatically	File name:

Mode:	
- FCC test setup	
- TX mode	
- with antenna : ANT 1	
- without TAG	

Detector: Peak / Final Results: QP	
---------------------------------------	--

Final results: 20 dB Margin	8 Subranges
--------------------------------	-------------

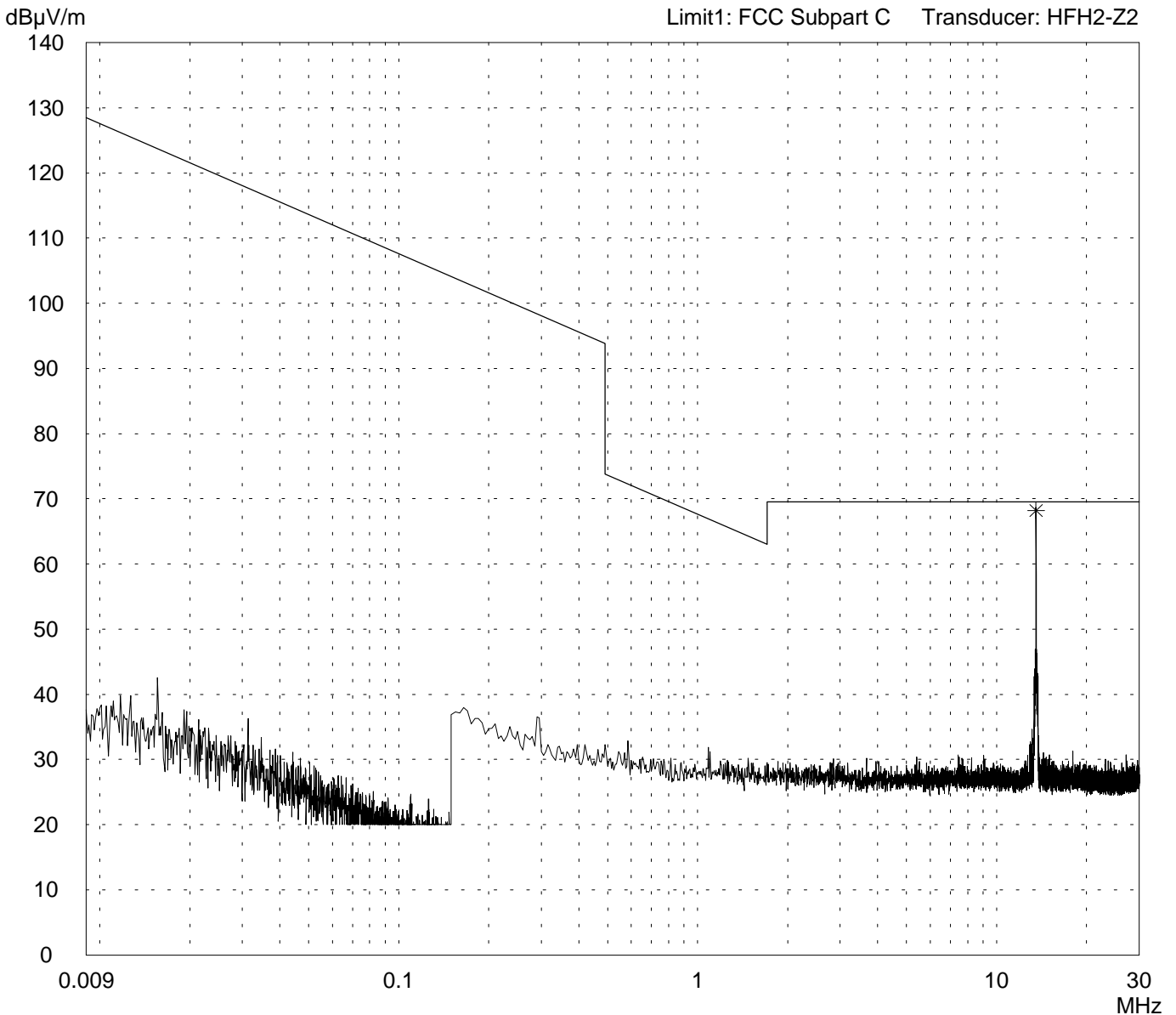

Result: Prescan

Project file: 51905-20108	Page of Pages
------------------------------	---------------

Radiated Emission Test 9 kHz - 30 MHz according to FCC Part 15 Subpart C

Model: Moby E MIFARE SLG 75	
Serial no.: --	
Applicant: Siemens AG, Fürth, A&D SE RD 12	
Test site: Shielded room, cabin no. 3	
Tested on: Test distance 3 metres Antenna orthogonal to EUT	
Date of test: 02/25/2002	Operator: T. Eberl
Test performed: automatically	File name:

Mode:	
- FCC test setup	
- TX mode	
- with antenna : ANT 12	
- with TAG	

Detector: Peak / Final Results: QP	
---------------------------------------	--

Final results: 20 dB Margin	8 Subranges
--------------------------------	-------------

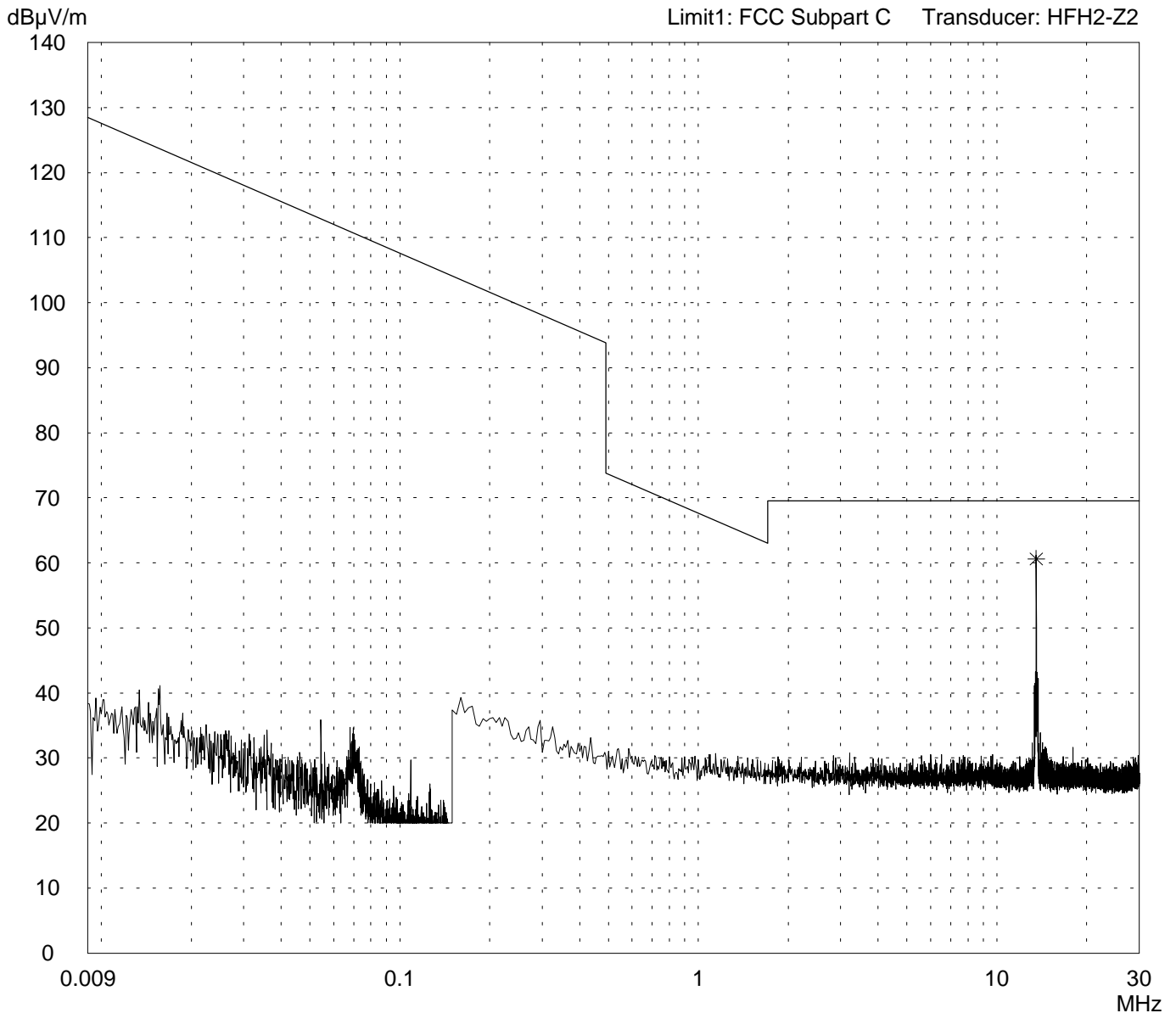

Result: Prescan

Project file: 51905-20108	Page of Pages
------------------------------	---------------------

Radiated Emission Test 9 kHz - 30 MHz according to FCC Part 15 Subpart C

Model: Moby E MIFARE SLG 75	
Serial no.: --	
Applicant: Siemens AG, Fürth, A&D SE RD 12	
Test site: Shielded room, cabin no. 3	
Tested on: Test distance 3 metres Antenna orthogonal to EUT	
Date of test: 02/25/2002	Operator: T. Eberl
Test performed: automatically	File name:

Mode:	
- FCC test setup	
- TX mode	
- with antenna : ANT 12	
- without TAG	

Detector: Peak / Final Results: QP	
---------------------------------------	--

Final results: 20 dB Margin	8 Subranges
--------------------------------	-------------

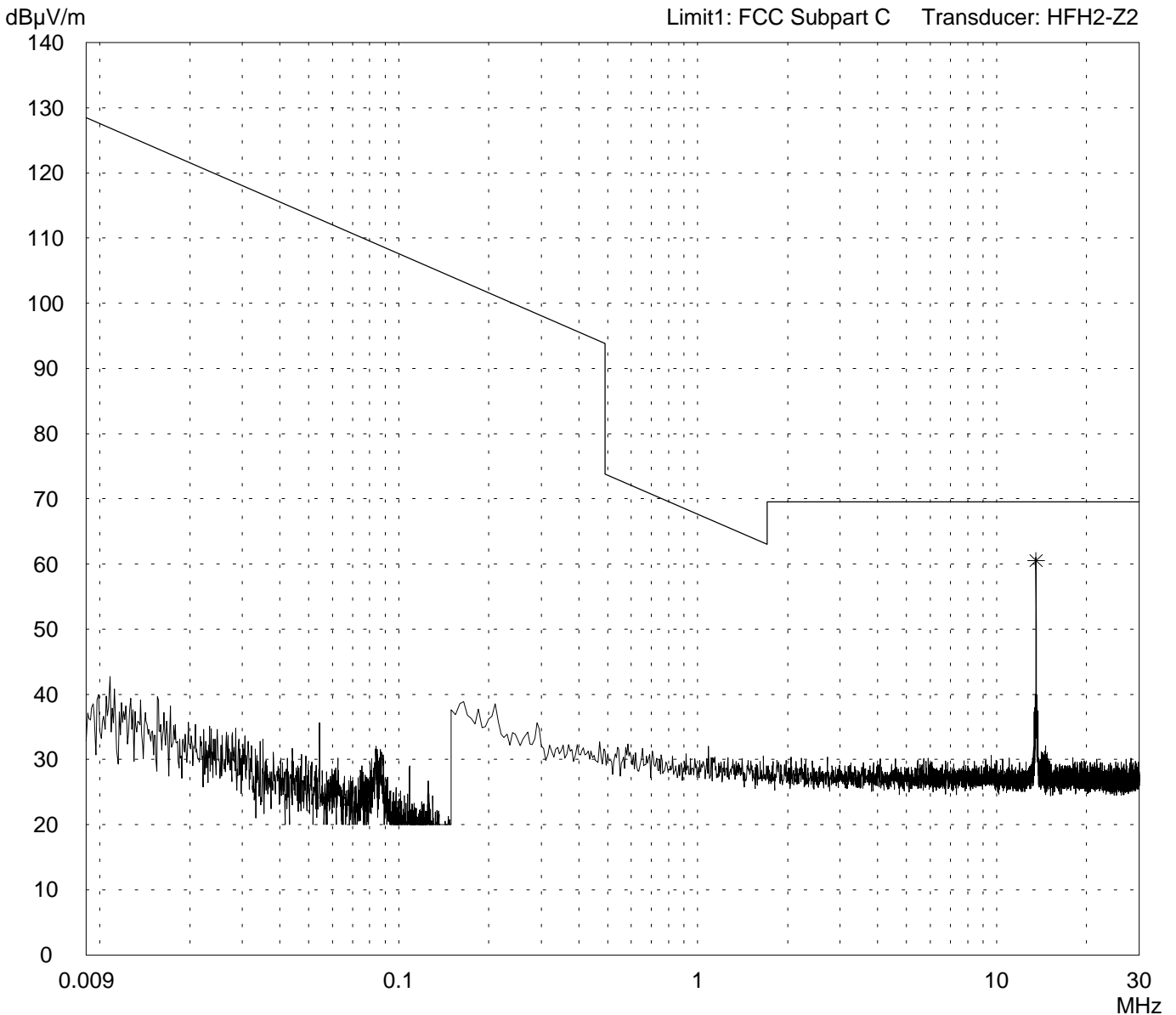

Result: Prescan

Project file: 51905-20108	Page of Pages
------------------------------	---------------

Radiated Emission Test 9 kHz - 30 MHz according to FCC Part 15 Subpart C

Model: Moby E MIFARE SLG 75	
Serial no.: --	
Applicant: Siemens AG, Fürth, A&D SE RD 12	
Test site: Shielded room, cabin no. 3	
Tested on: Test distance 3 metres Antenna orthogonal to EUT	
Date of test: 02/25/2002	Operator: T. Eberl
Test performed: automatically	File name:

Mode: - FCC test setup - TX mode - with antenna : ANT 18 - with TAG

Detector: Peak / Final Results: QP

Final results: 20 dB Margin	8 Subranges
--------------------------------	-------------

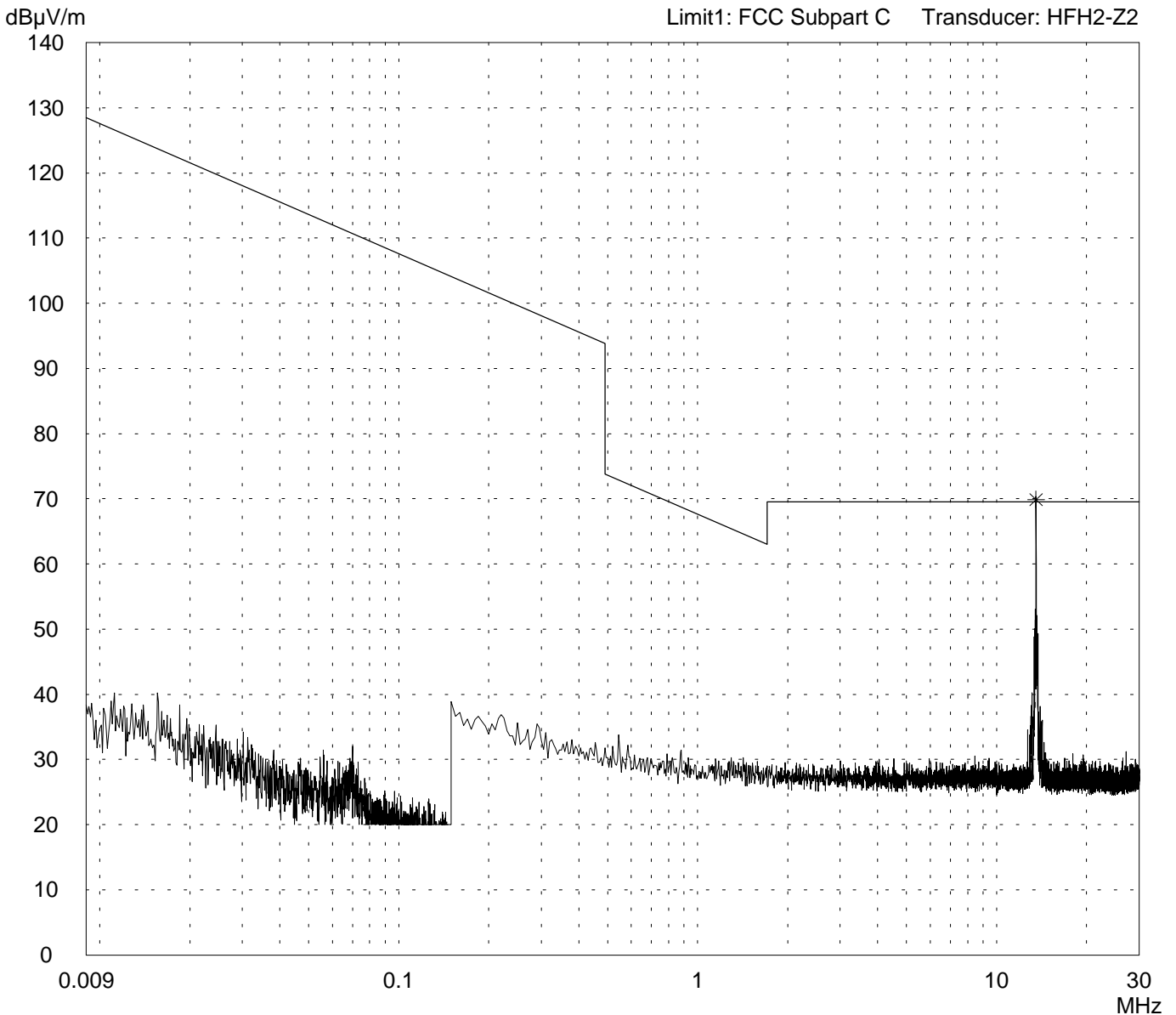

Result: Prescan

Project file: 51905-20108	Page of Pages
------------------------------	---------------

Radiated Emission Test 9 kHz - 30 MHz according to FCC Part 15 Subpart C

Model: Moby E MIFARE SLG 75	
Serial no.: --	
Applicant: Siemens AG, Fürth, A&D SE RD 12	
Test site: Shielded room, cabin no. 3	
Tested on: Test distance 3 metres Antenna orthogonal to EUT	
Date of test: 02/25/2002	Operator: T. Eberl
Test performed: automatically	File name:

Mode:	
- FCC test setup	
- TX mode	
- with antenna : ANT 18	
- without TAG	

Detector: Peak / Final Results: QP	
---------------------------------------	--

Final results: 20 dB Margin	8 Subranges
--------------------------------	-------------

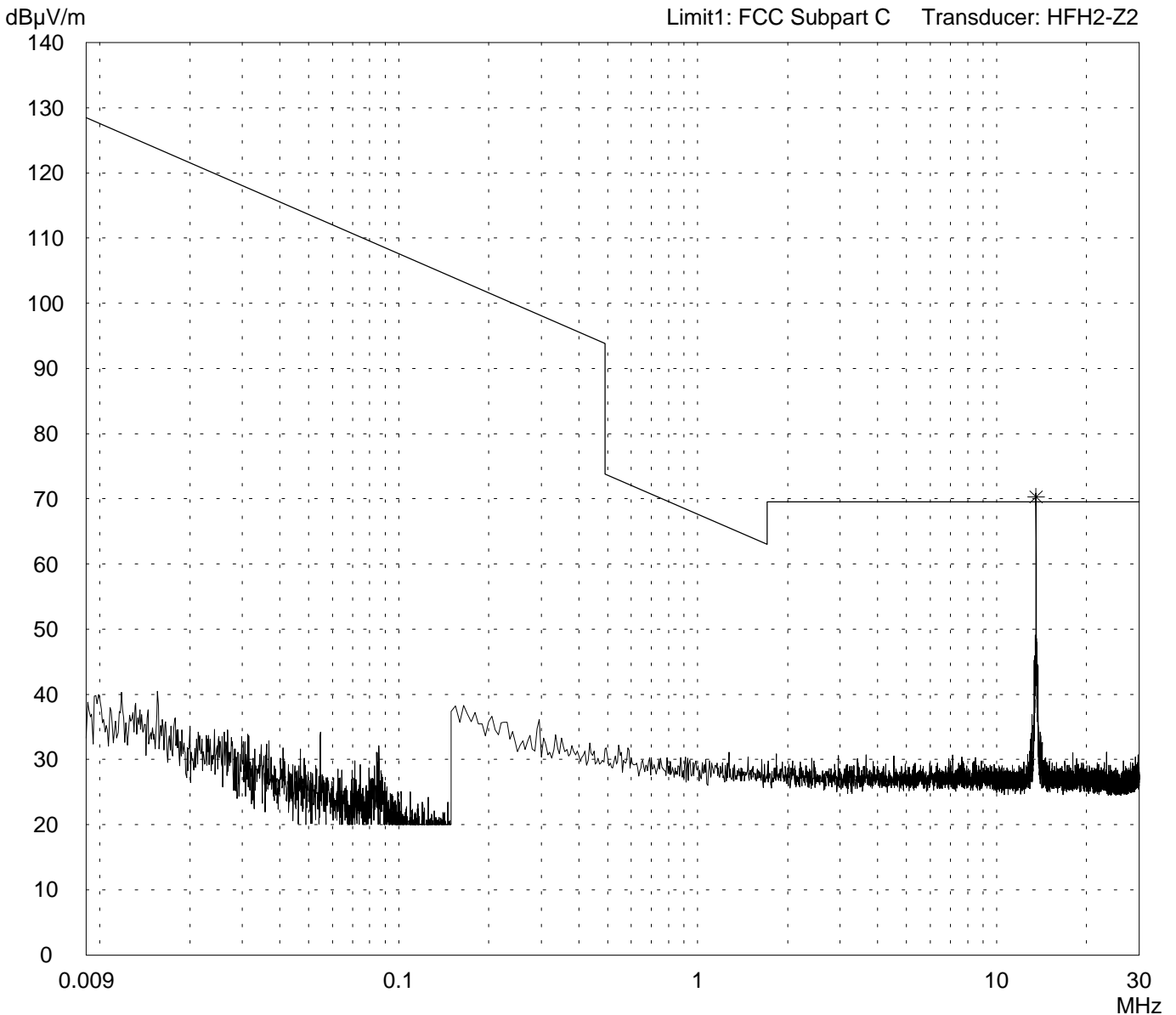

Result: Prescan

Project file: 51905-20108	Page of Pages
------------------------------	---------------

Radiated Emission Test 9 kHz - 30 MHz according to FCC Part 15 Subpart C

Model: Moby E MIFARE SLG 75	
Serial no.: --	
Applicant: Siemens AG, Fürth, A&D SE RD 12	
Test site: Shielded room, cabin no. 3	
Tested on: Test distance 3 metres Antenna orthogonal to EUT	
Date of test: 02/25/2002	Operator: T. Eberl
Test performed: automatically	File name:

Mode: - FCC test setup - TX mode - with antenna : ANT 30 - with TAG	
---	--

Detector: Peak / Final Results: QP

Final results: 20 dB Margin	8 Subranges
--------------------------------	-------------

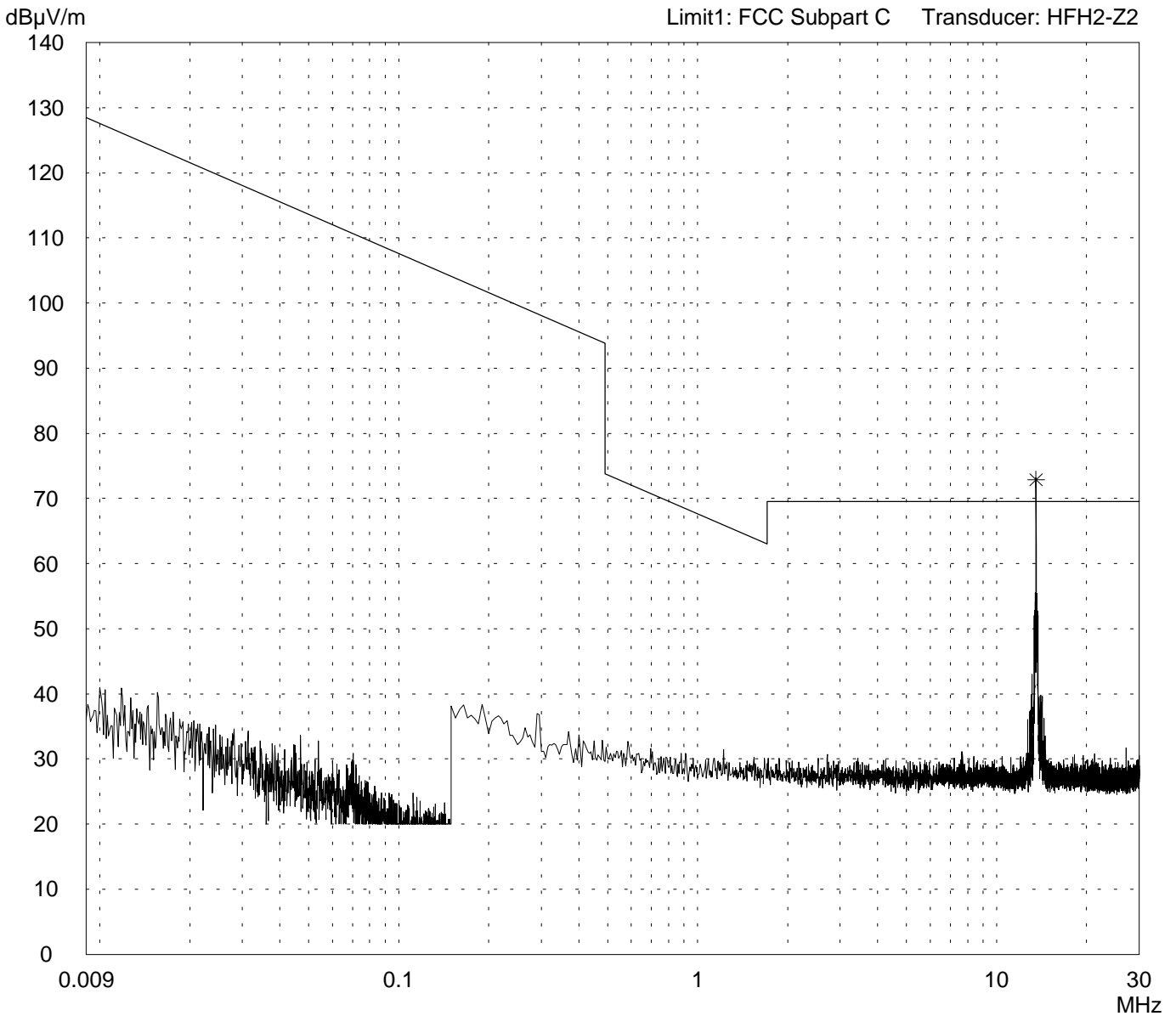

Result: Prescan

Project file: 51905-20108	Page of Pages
------------------------------	---------------

Radiated Emission Test 9 kHz - 30 MHz according to FCC Part 15 Subpart C

Model: Moby E MIFARE SLG 75	
Serial no.: --	
Applicant: Siemens AG, Fürth, A&D SE RD 12	
Test site: Shielded room, cabin no. 3	
Tested on: Test distance 3 metres Antenna orthogonal to EUT	
Date of test: 02/25/2002	Operator: T. Eberl
Test performed: automatically	File name:

Mode:	
- FCC test setup	
- TX mode	
- with antenna : ANT 30	
- without TAG	

Detector: Peak / Final Results: QP

Final results: 20 dB Margin	8 Subranges
--------------------------------	-------------

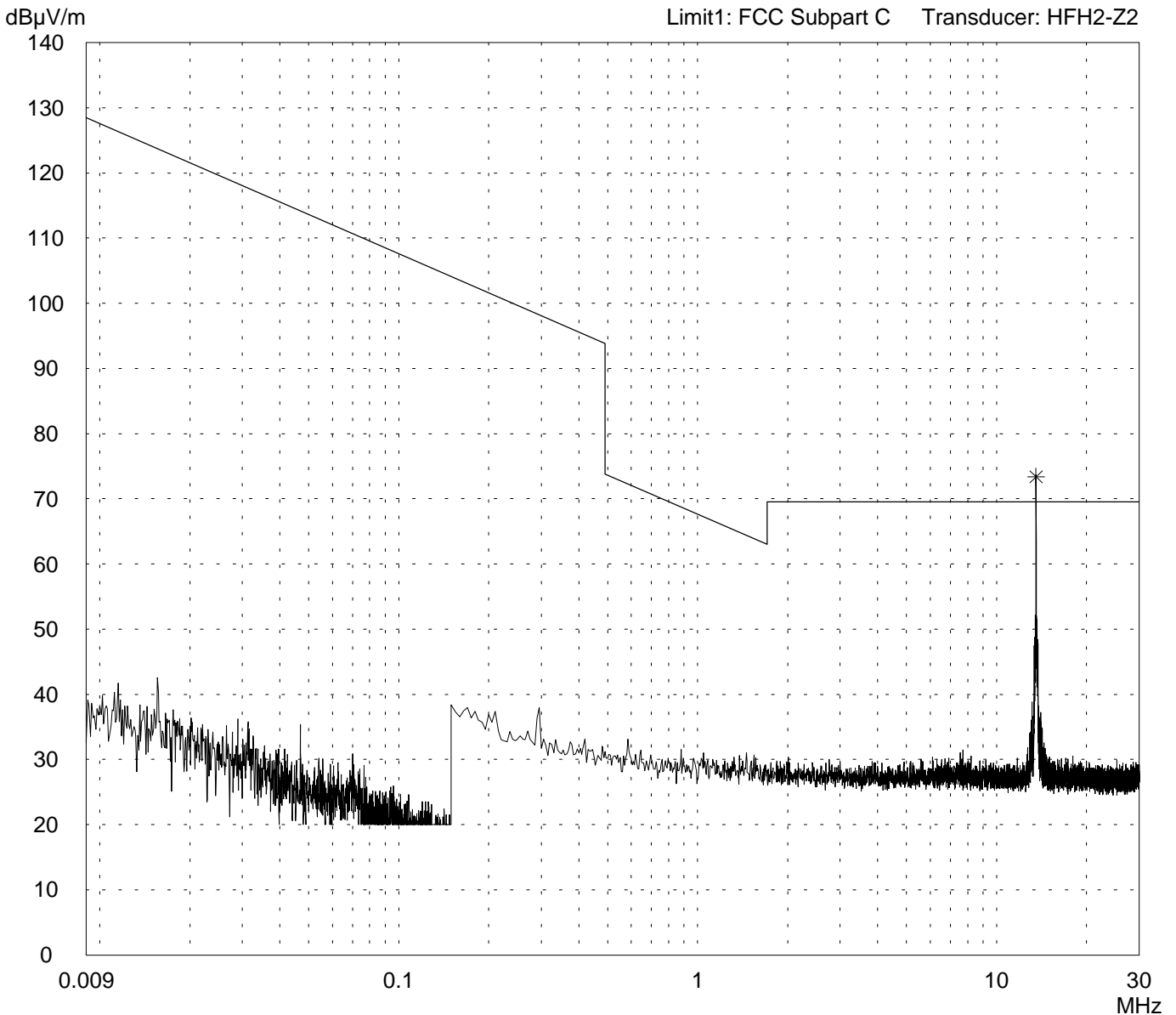

Result: Prescan

Project file: 51905-20108	Page of Pages
------------------------------	---------------------

Radiated Emission Test 30 MHz - 200 MHz acc. to FCC Part 15 (Fully Anechoic Chamber)

Model: SLG 75	Comment: - TX mode - FCC test setup - ANT 1
Serial no.: --	
Applicant: Siemens AG, Fürth	
Test site: Fully anechoic room	
Tested on: Test distance 3 metres Horizontal Polarization	
Date of test: 07/19/2002	Operator: T. Eberl
Test performed: automatically	File name: default.emi

Detector: Peak	List of values: 10 dB Margin 8 Subranges
--------------------------	---

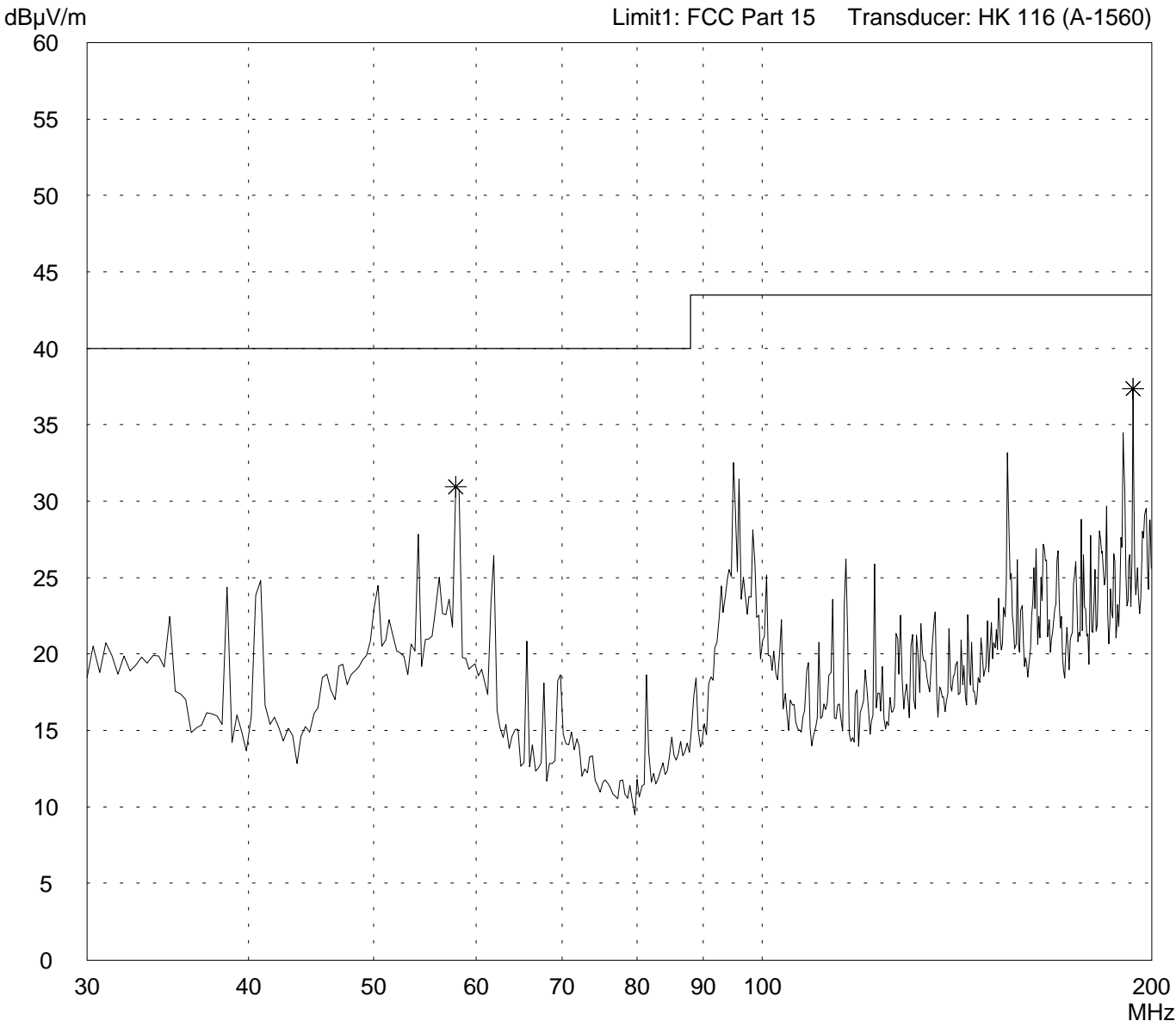

Result: Prescan	Project file: 51905-20108
	Page of Pages

Radiated Emission Test 30 MHz - 200 MHz acc. to FCC Part 15 (Fully Anechoic Chamber)

Model: SLG 75	Comment: - TX mode - FCC test setup - ANT 30
Serial no.: --	
Applicant: Siemens AG, Fürth	
Test site: Fully anechoic room	
Tested on: Test distance 3 metres Horizontal Polarization	
Date of test: 07/19/2002	Operator: T. Eberl
Test performed: automatically	File name: default.emi

Detector: Peak	List of values: 10 dB Margin 8 Subranges
--------------------------	---

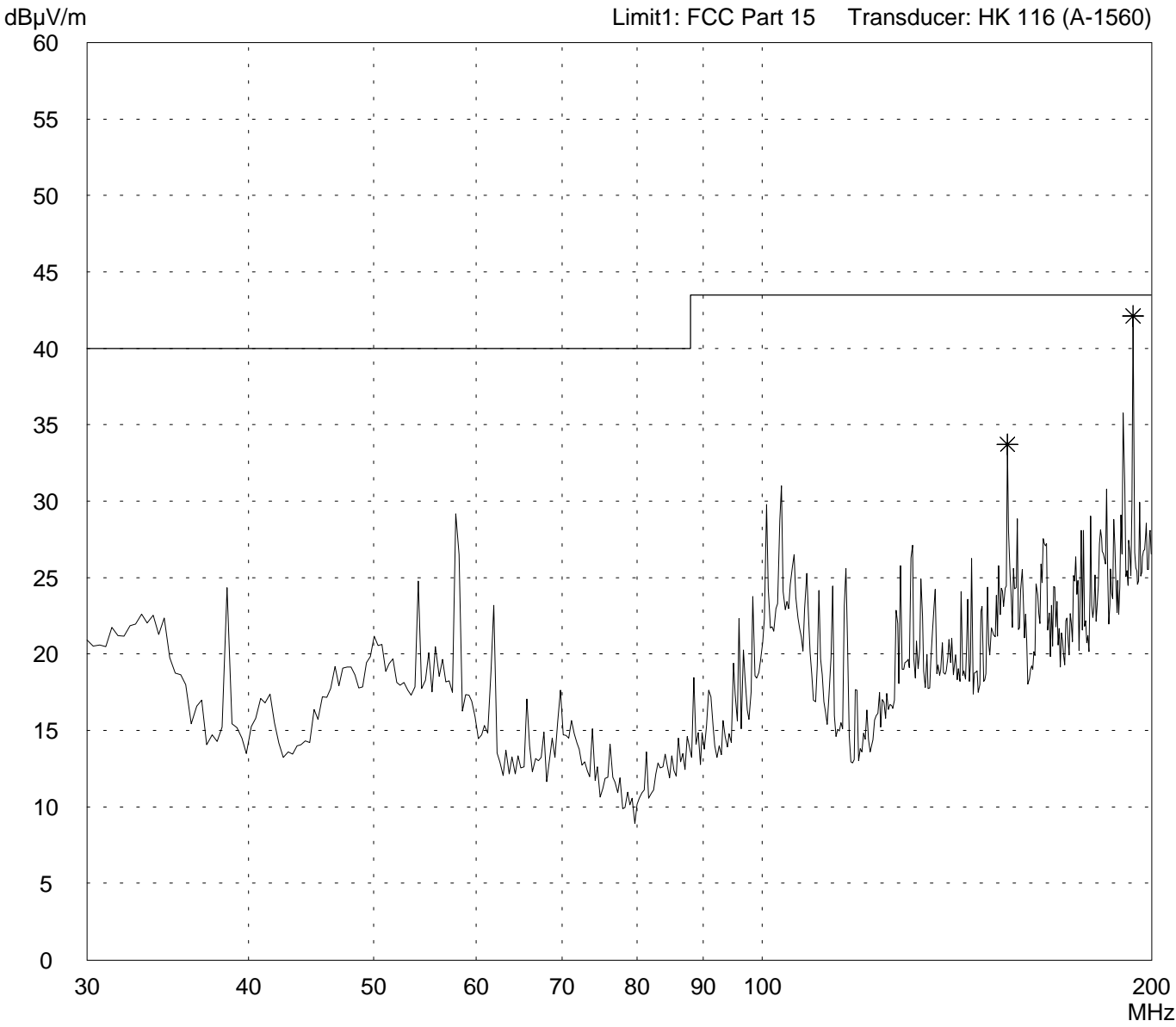

Result: Prescan	Project file: 51905-20108
	Page of Pages

Radiated Emission Test 30 MHz - 200 MHz acc. to FCC Part 15 (Fully Anechoic Chamber)

Model: SLG 75	Comment: - TX mode - FCC test setup - ANT 18
Serial no.: --	
Applicant: Siemens AG, Fürth	
Test site: Fully anechoic room	
Tested on: Test distance 3 metres Horizontal Polarization	
Date of test: 07/19/2002	Operator: T. Eberl
Test performed: automatically	File name: default.emi

Detector: Peak	List of values: 10 dB Margin 8 Subranges
--------------------------	---

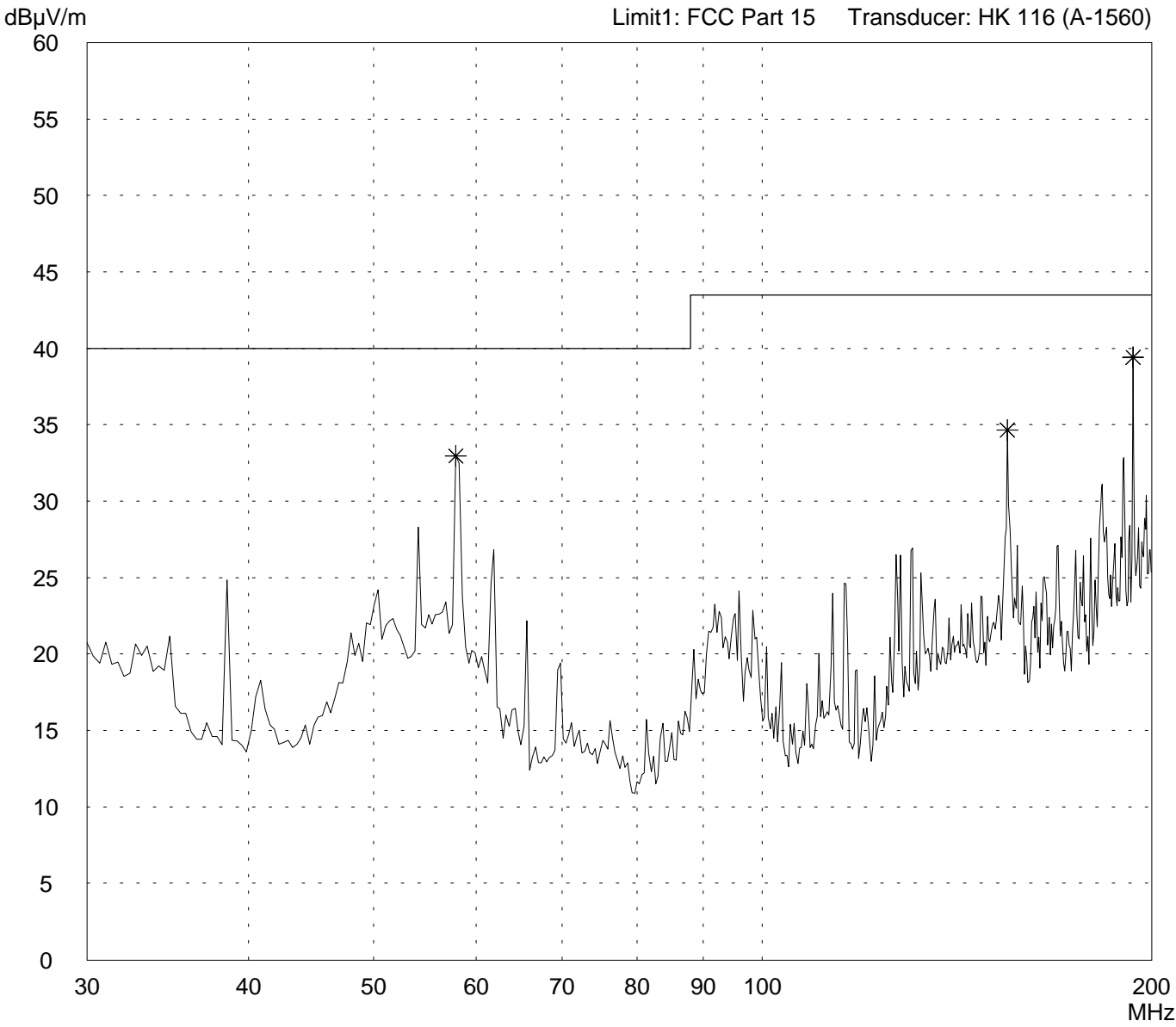

Result: Prescan	Project file: 51905-20108
	Page of Pages

Radiated Emission Test 30 MHz - 200 MHz acc. to FCC Part 15 (Fully Anechoic Chamber)

Model: SLG 75	Comment: - TX mode - FCC test setup - ANT 12
Serial no.: --	
Applicant: Siemens AG, Fürth	
Test site: Fully anechoic room	
Tested on: Test distance 3 metres Horizontal Polarization	
Date of test: 07/19/2002	Operator: T. Eberl
Test performed: automatically	File name: default.emi

Detector: Peak	List of values: 10 dB Margin 8 Subranges
--------------------------	---

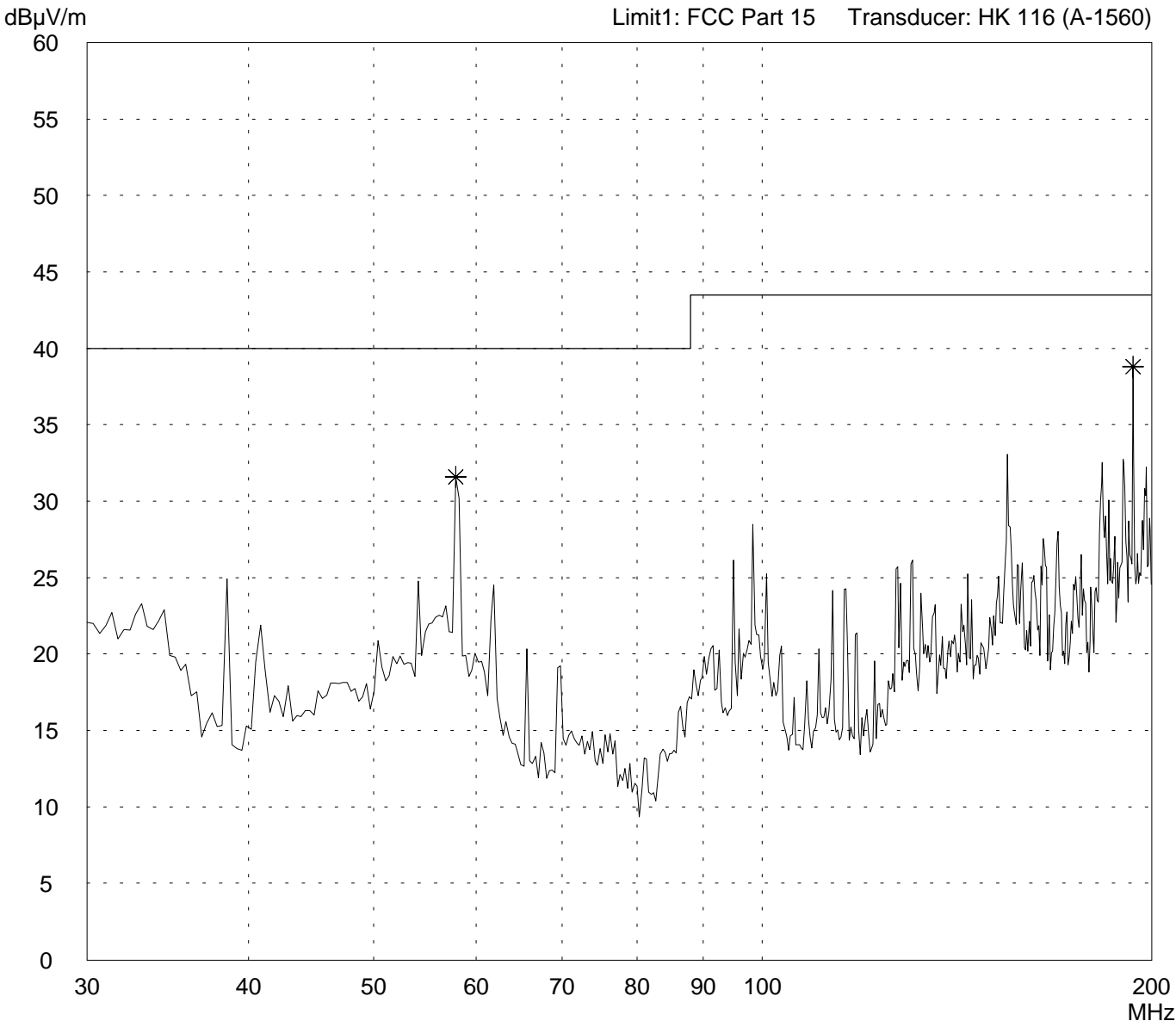

Result: Prescan	Project file: 51905-20108
	Page of Pages

Radiated Emission Test 200 MHz - 1 GHz acc. to FCC Part 15 (Fully Anechoic Chamber)

Model: SLG 75	Comment: - TX mode - FCC test setup - ANT 1
Serial no.: --	
Applicant: Siemens AG, Fürth	
Test site: Fully anechoic room	
Tested on: Test distance 3 metres Horizontal Polarization	
Date of test: 07/19/2002	Operator: T. Eberl
Test performed: automatically	File name: default.emi

Detector: Peak	List of values: 10 dB Margin 8 Subranges
--------------------------	---

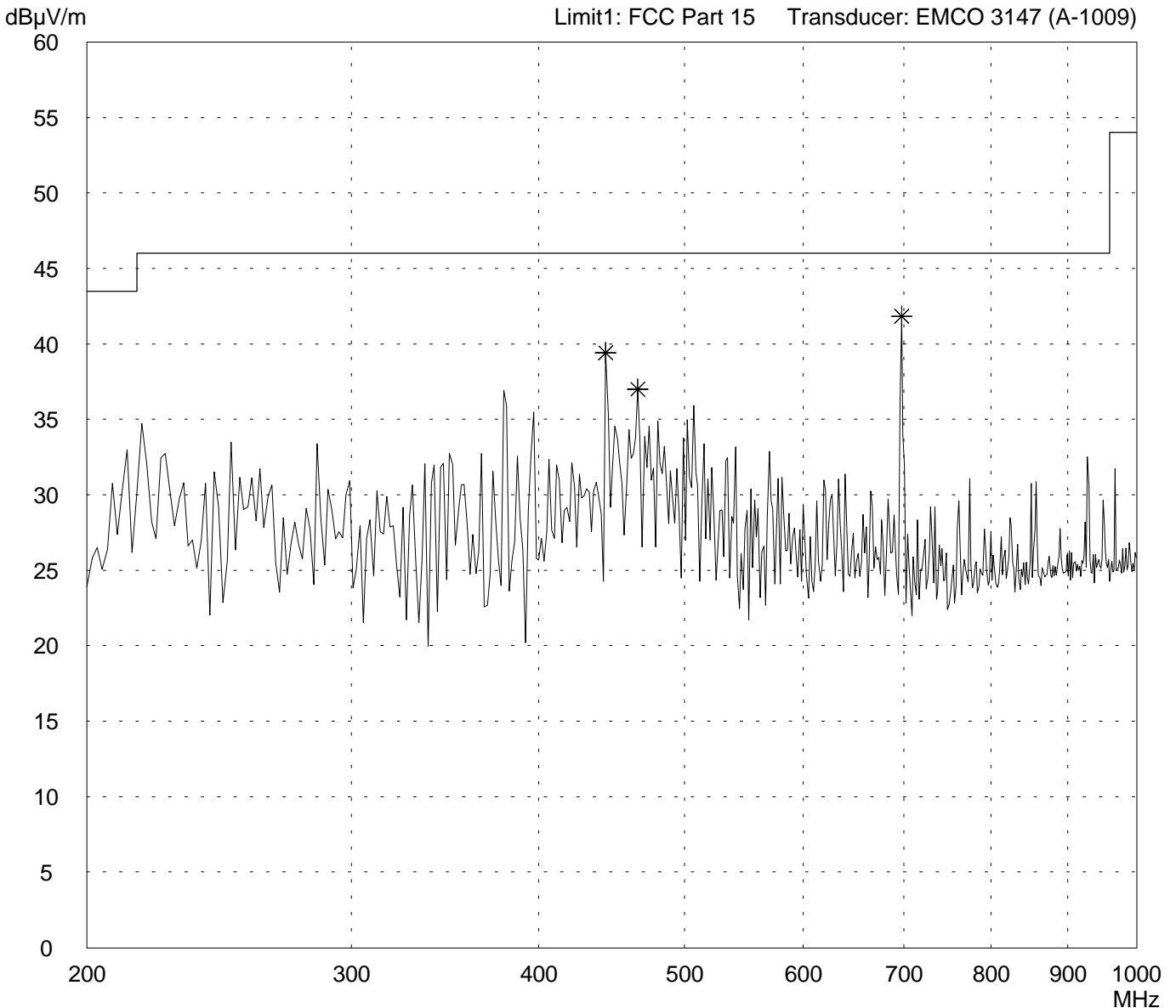

Result: Prescan	Project file: 51905-20108
	Page of Pages

Radiated Emission Test 200 MHz - 1 GHz acc. to FCC Part 15 (Fully Anechoic Chamber)

Model: SLG 75	Comment: - TX mode - FCC test setup - ANT 30
Serial no.: --	
Applicant: Siemens AG, Fürth	
Test site: Fully anechoic room	
Tested on: Test distance 3 metres Horizontal Polarization	
Date of test: 07/19/2002	Operator: T. Eberl
Test performed: automatically	File name: default.emi

Detector: Peak	List of values: 10 dB Margin 8 Subranges
--------------------------	---

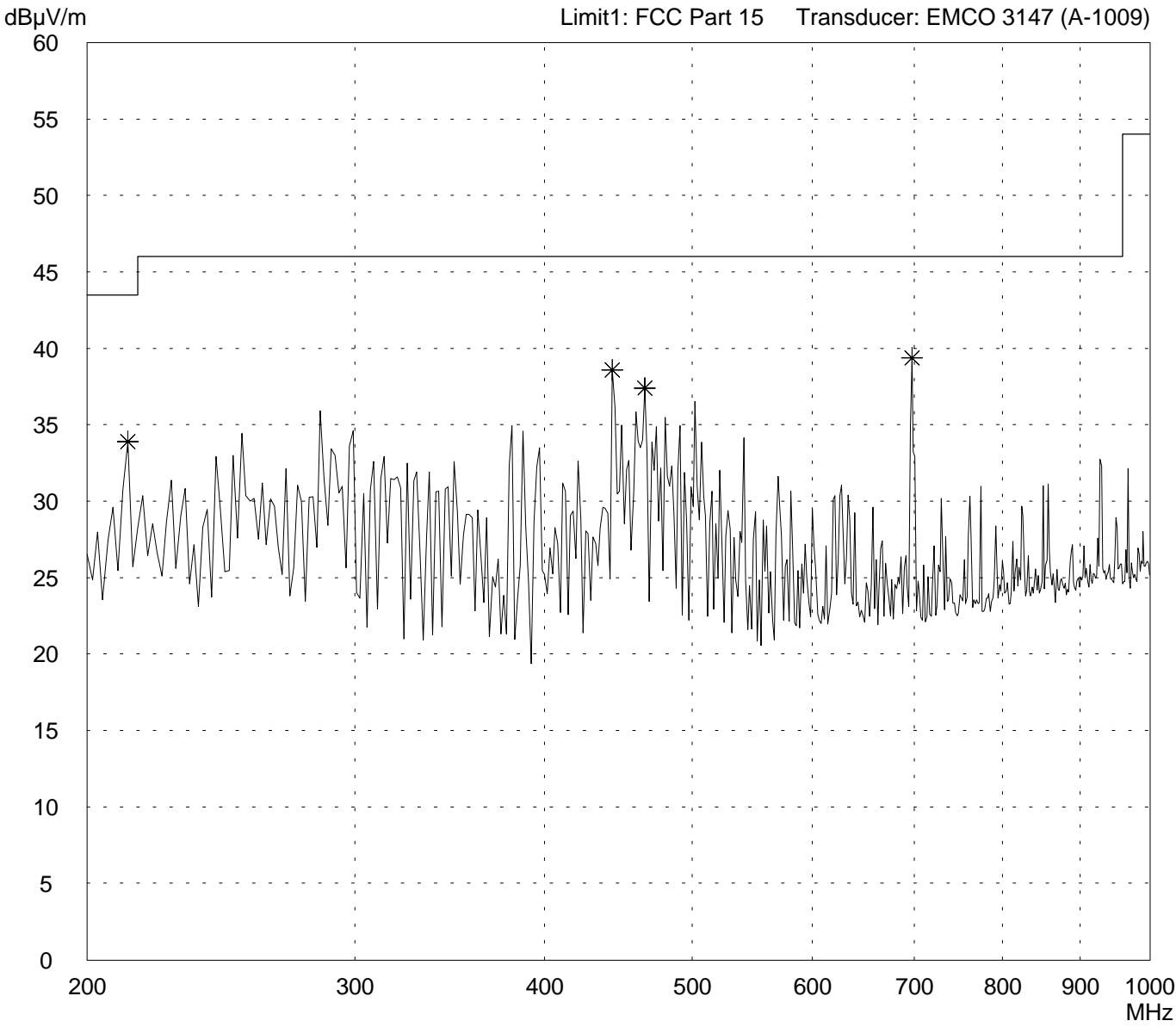

Result: Prescan	Project file: 51905-20108
	Page of Pages

Radiated Emission Test 200 MHz - 1 GHz acc. to FCC Part 15 (Fully Anechoic Chamber)

<p>Model: SLG 75</p> <p>Serial no.: --</p> <p>Applicant: Siemens AG, Fürth</p> <p>Test site: Fully anechoic room</p> <p>Tested on: Test distance 3 metres Horizontal Polarization</p> <p>Date of test: 07/19/2002 Operator: T. Eberl</p> <p>Test performed: automatically File name: default.emi</p>	<p>Comment:</p> <ul style="list-style-type: none"> - TX mode - FCC test setup - ANT 18
--	---

<p>Detector: Peak</p>	<p>List of values: 10 dB Margin 8 Subranges</p>
----------------------------------	---

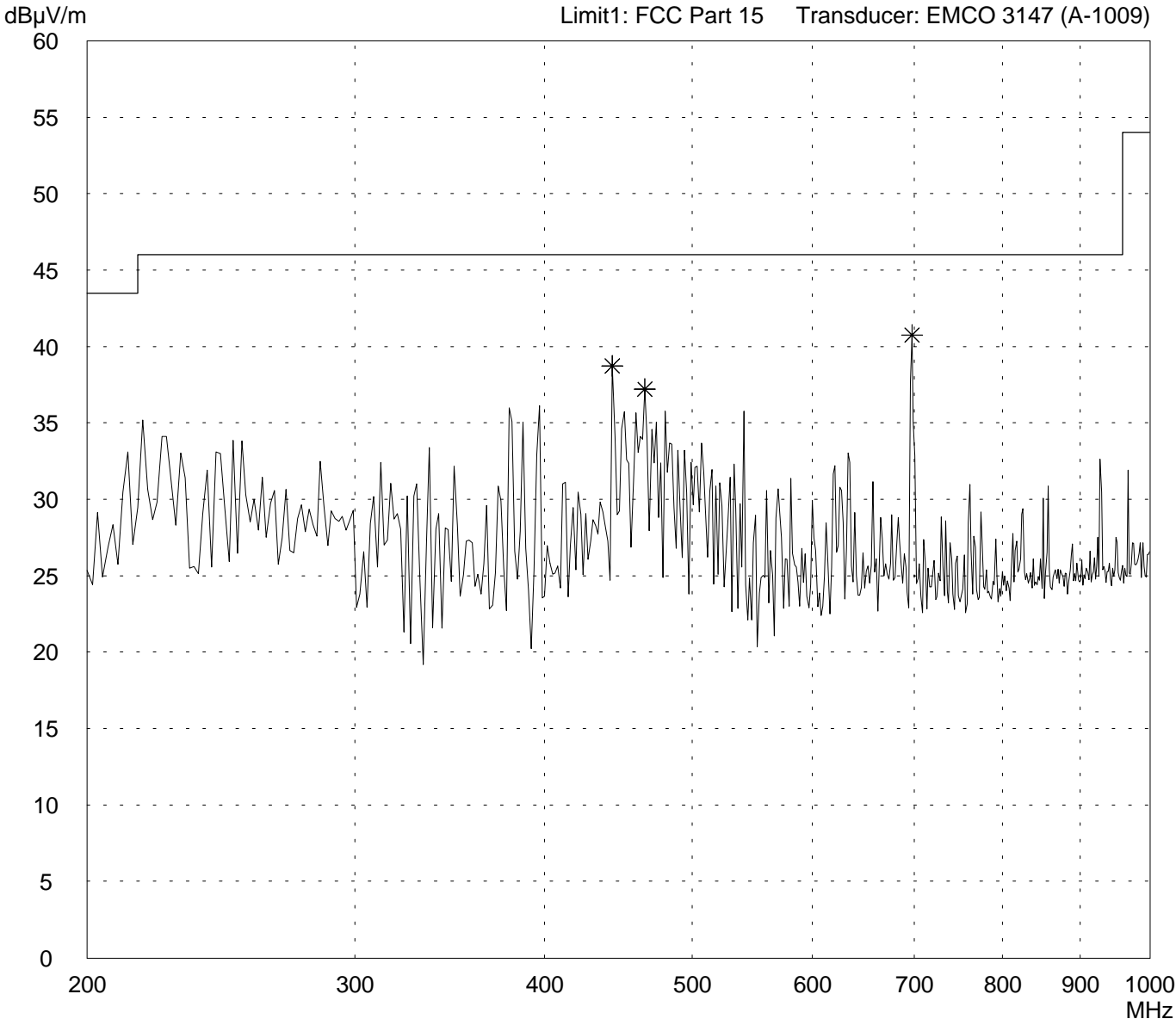

<p>Result: Prescan</p>	<p>Project file: 51905-20108</p> <p style="text-align: right;">Page of Pages</p>
-----------------------------------	---

Radiated Emission Test 200 MHz - 1 GHz acc. to FCC Part 15 (Fully Anechoic Chamber)

Model: SLG 75	Comment: - TX mode - FCC test setup - ANT 12
Serial no.: --	
Applicant: Siemens AG, Fürth	
Test site: Fully anechoic room	
Tested on: Test distance 3 metres Horizontal Polarization	
Date of test: 07/19/2002	Operator: T. Eberl
Test performed: automatically	File name: default.emi

Detector: Peak	List of values: 10 dB Margin 8 Subranges
--------------------------	---

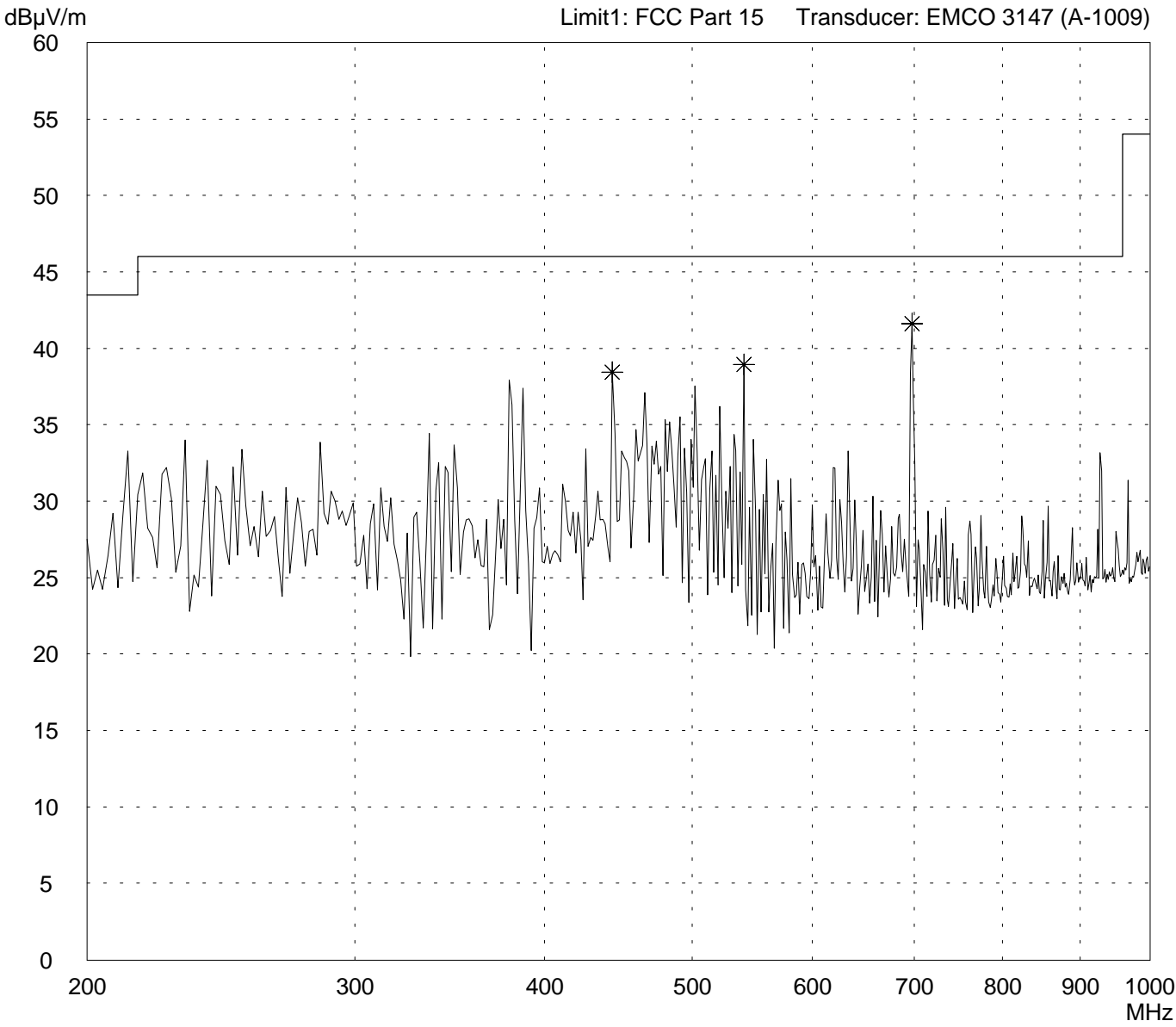

Result: Prescan	Project file: 51905-20108
	Page of Pages

Radiated Emission Test 30 MHz - 200 MHz acc. to FCC Part 15 (Fully Anechoic Chamber)

Model: SLG 75	Comment: - TX mode - FCC test setup - ANT 1
Serial no.: --	
Applicant: Siemens AG, Fürth	
Test site: Fully anechoic room	
Tested on: Test distance 3 metres Vertical Polarization	
Date of test: 07/19/2002	Operator: T. Eberl
Test performed: automatically	File name: default.emi

Detector: Peak	List of values: 10 dB Margin 8 Subranges
--------------------------	---

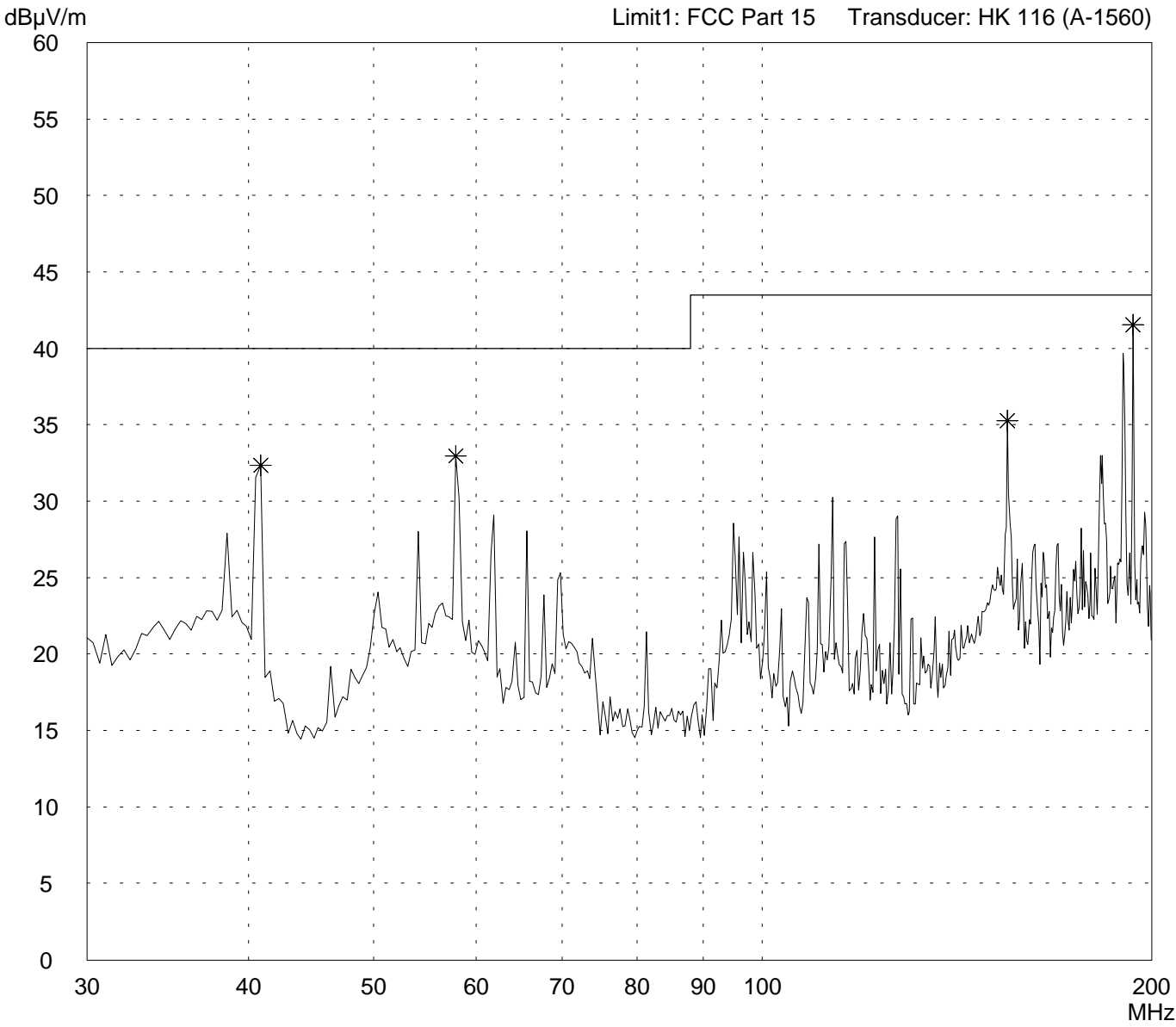

Result: Prescan	Project file: 51905-20108
	Page of Pages

Radiated Emission Test 30 MHz - 200 MHz acc. to FCC Part 15 (Fully Anechoic Chamber)

Model: SLG 75	Comment: - TX mode - FCC test setup - ANT 30
Serial no.: --	
Applicant: Siemens AG, Fürth	
Test site: Fully anechoic room	
Tested on: Test distance 3 metres Vertical Polarization	
Date of test: 07/19/2002	Operator: T. Eberl
Test performed: automatically	File name: default.emi

Detector: Peak	List of values: 10 dB Margin 8 Subranges
--------------------------	---

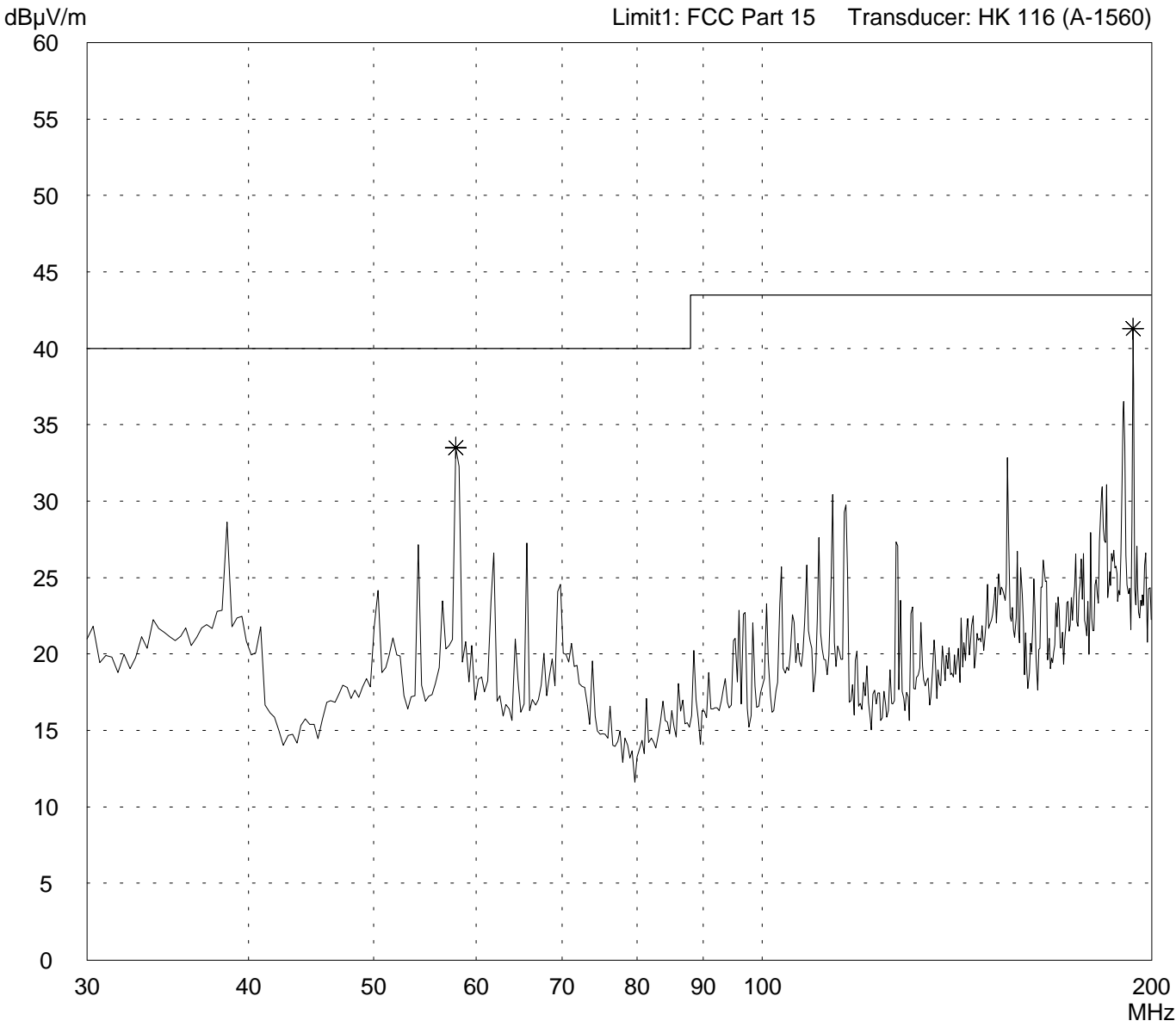

Result: Prescan	Project file: 51905-20108
	Page of Pages

Radiated Emission Test 30 MHz - 200 MHz acc. to FCC Part 15 (Fully Anechoic Chamber)

<p>Model: SLG 75</p> <p>Serial no.: --</p> <p>Applicant: Siemens AG, Fürth</p> <p>Test site: Fully anechoic room</p> <p>Tested on: Test distance 3 metres Vertical Polarization</p> <p>Date of test: 07/19/2002 Operator: T. Eberl</p> <p>Test performed: automatically File name: default.emi</p>	<p>Comment:</p> <ul style="list-style-type: none"> - TX mode - FCC test setup - ANT 18
--	---

<p>Detector: Peak</p>	<p>List of values: 10 dB Margin 8 Subranges</p>
----------------------------------	---

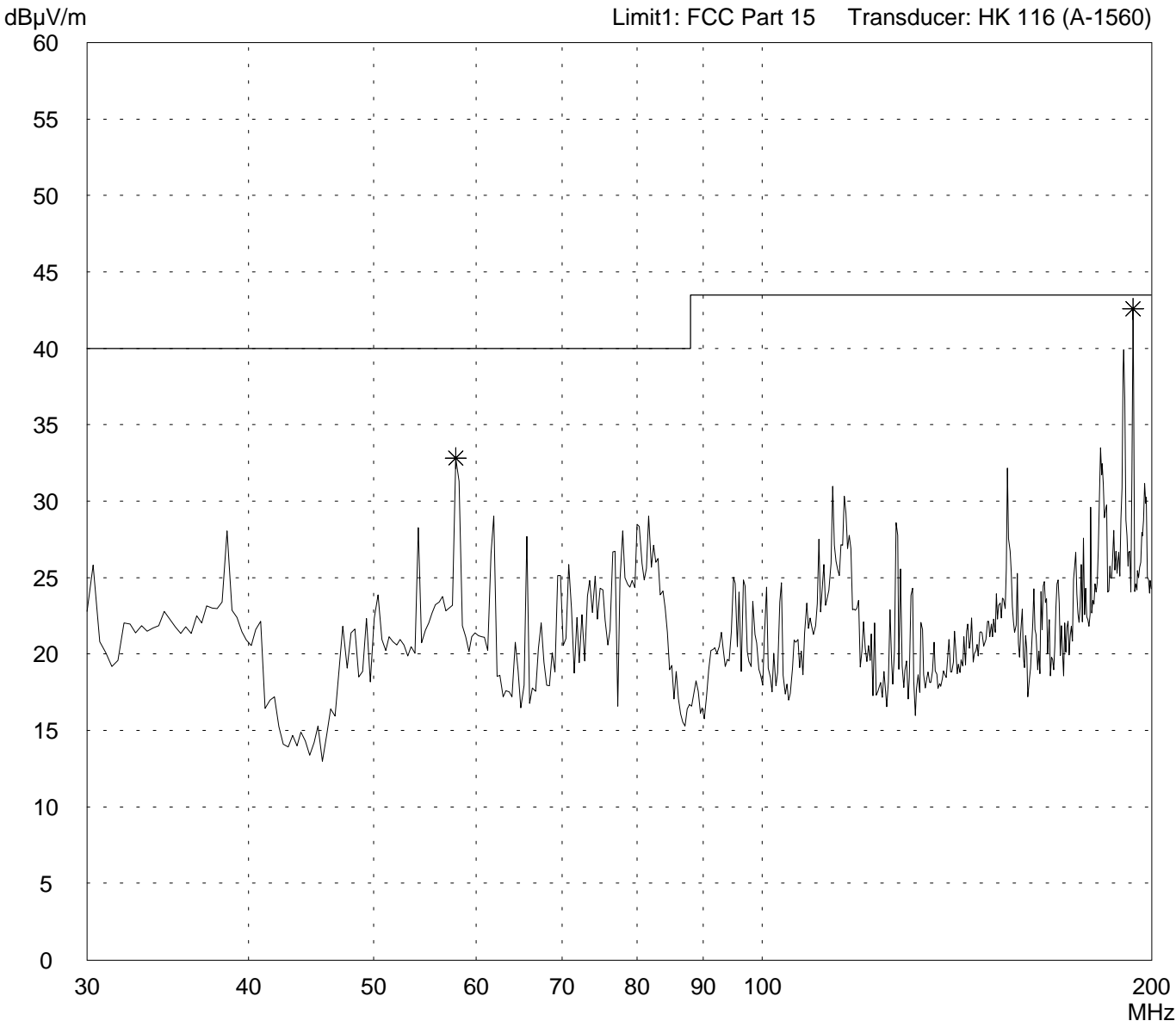

<p>Result: Prescan</p>	<p>Project file: 51905-20108</p> <p style="text-align: right;">Page of Pages</p>
-----------------------------------	---

Radiated Emission Test 30 MHz - 200 MHz acc. to FCC Part 15 (Fully Anechoic Chamber)

Model: SLG 75	Comment: - TX mode - FCC test setup - ANT 12
Serial no.: --	
Applicant: Siemens AG, Fürth	
Test site: Fully anechoic room	
Tested on: Test distance 3 metres Vertical Polarization	
Date of test: 07/19/2002	Operator: T. Eberl
Test performed: automatically	File name: default.emi

Detector: Peak	List of values: 10 dB Margin 8 Subranges
--------------------------	---

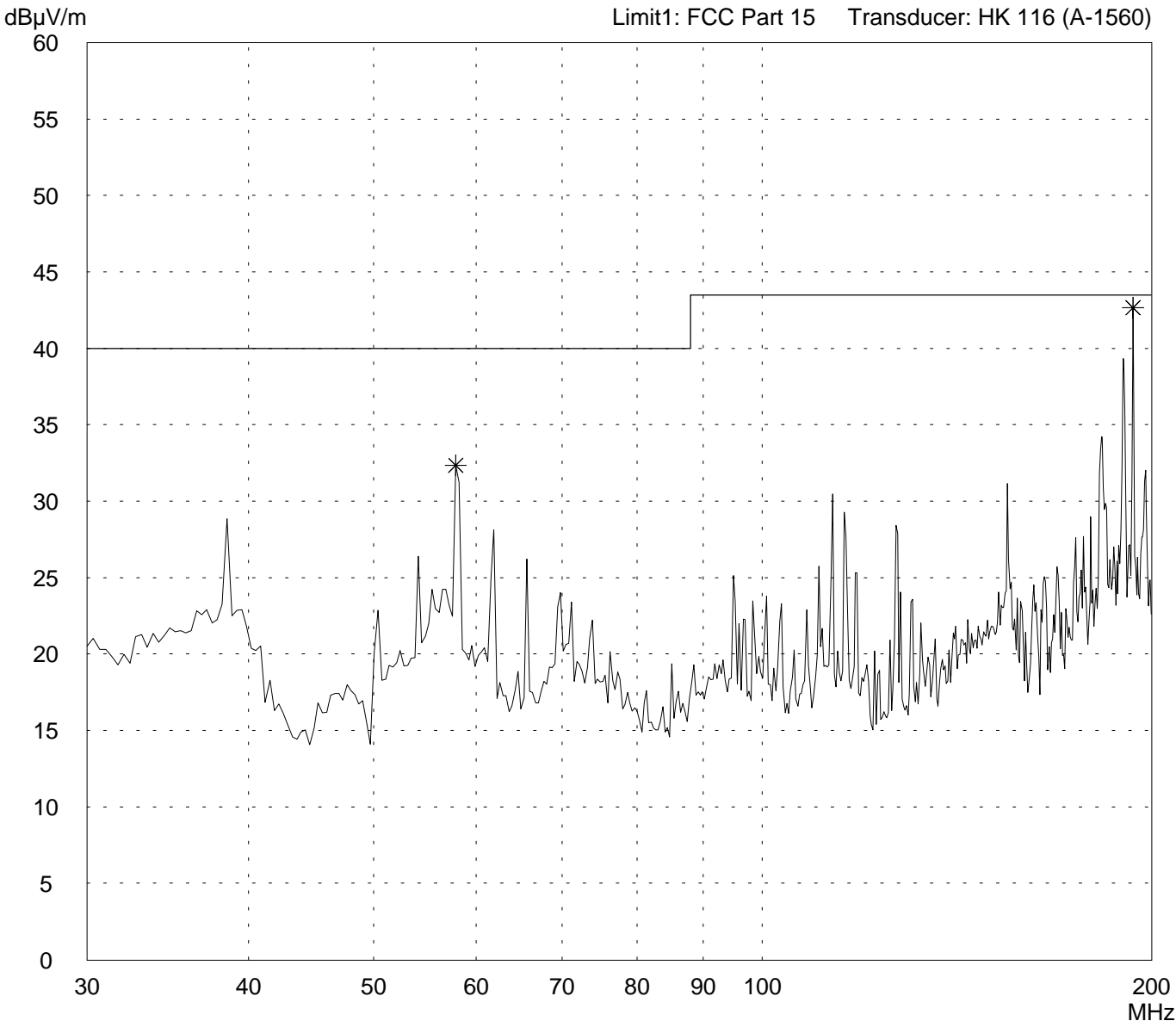

Result: Prescan	Project file: 51905-20108
	Page of Pages

Radiated Emission Test 200 MHz - 1 GHz acc. to FCC Part 15 (Fully Anechoic Chamber)

Model: SLG 75	Comment: - TX mode - FCC test setup - ANT 1
Serial no.: --	
Applicant: Siemens AG, Fürth	
Test site: Fully anechoic room	
Tested on: Test distance 3 metres Vertical Polarization	
Date of test: 07/19/2002	Operator: T. Eberl
Test performed: automatically	File name: default.emi

Detector: Peak	List of values: 10 dB Margin 8 Subranges
--------------------------	---

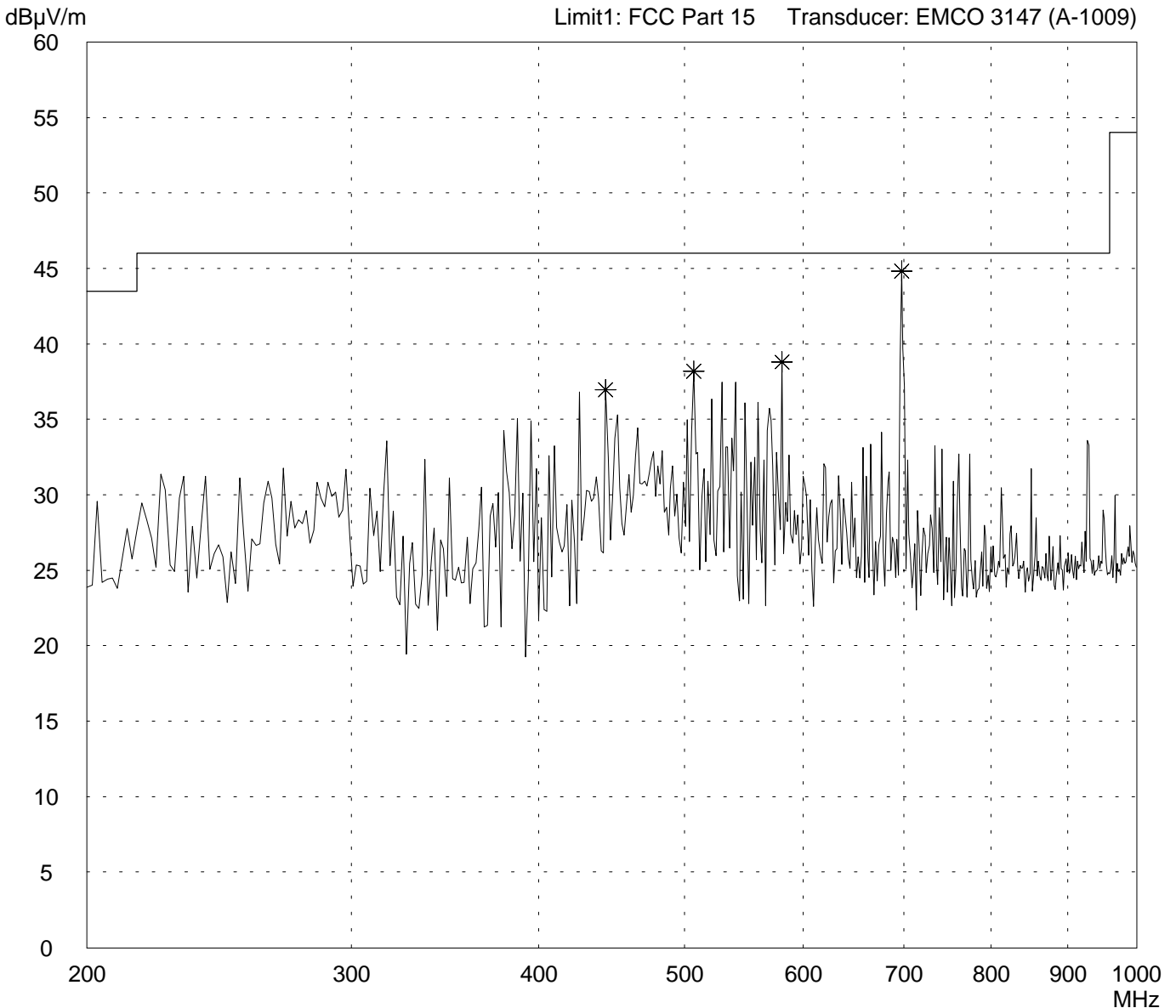

Result: Prescan	Project file: 51905-20108
	Page of Pages

Radiated Emission Test 200 MHz - 1 GHz acc. to FCC Part 15 (Fully Anechoic Chamber)

Model: SLG 75	Comment: - TX mode - FCC test setup - ANT 30
Serial no.: --	
Applicant: Siemens AG, Fürth	
Test site: Fully anechoic room	
Tested on: Test distance 3 metres Vertical Polarization	
Date of test: 07/19/2002	Operator: T. Eberl
Test performed: automatically	File name: default.emi

Detector: Peak	List of values: 10 dB Margin 8 Subranges
--------------------------	---

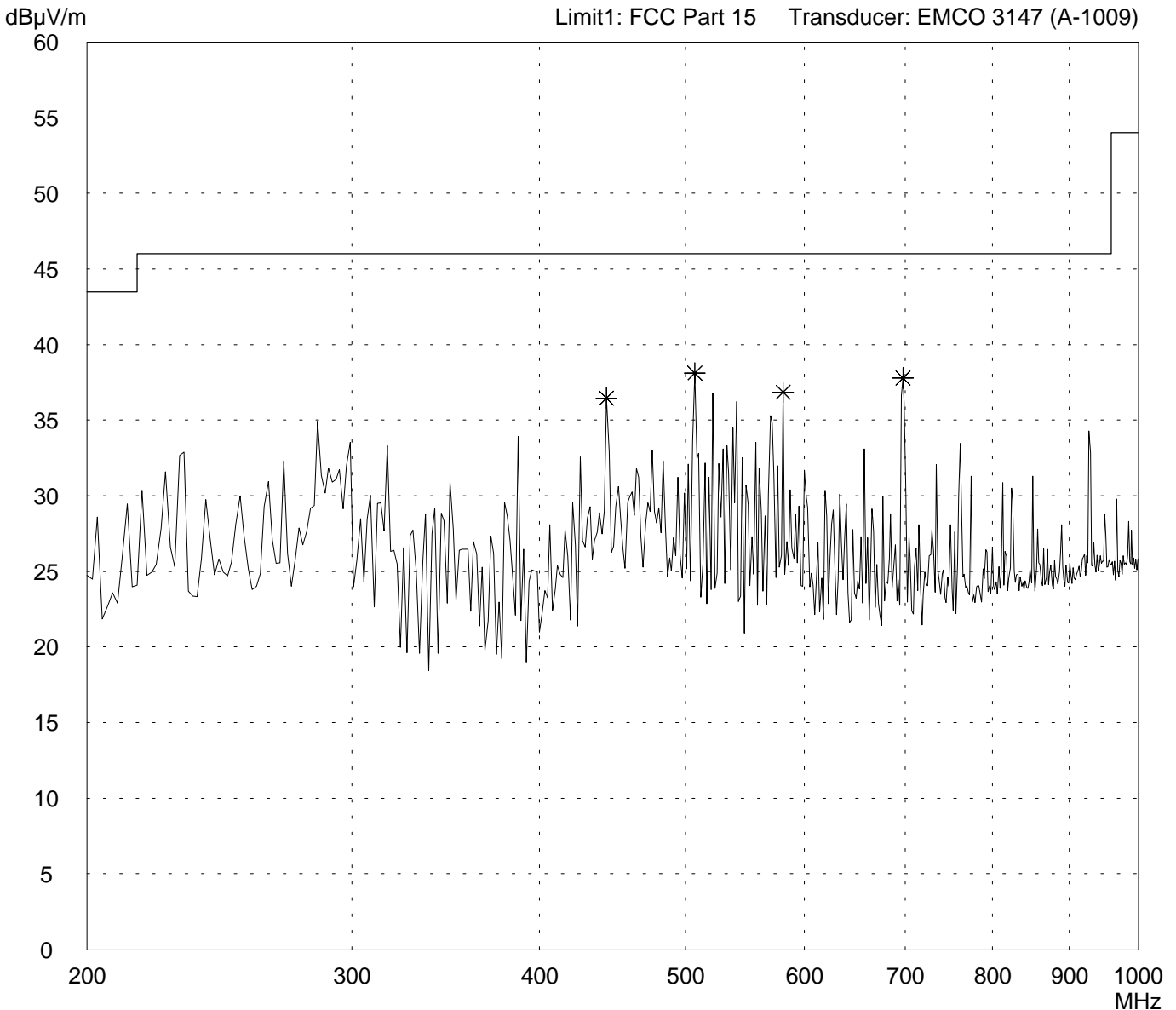

Result: Prescan	Project file: 51905-20108
	Page of Pages

Radiated Emission Test 200 MHz - 1 GHz acc. to FCC Part 15 (Fully Anechoic Chamber)

Model: SLG 75	Comment: - TX mode - FCC test setup - ANT 18
Serial no.: --	
Applicant: Siemens AG, Fürth	
Test site: Fully anechoic room	
Tested on: Test distance 3 metres Vertical Polarization	
Date of test: 07/19/2002	Operator: T. Eberl
Test performed: automatically	File name: default.emi

Detector: Peak	List of values: 10 dB Margin 8 Subranges
--------------------------	---

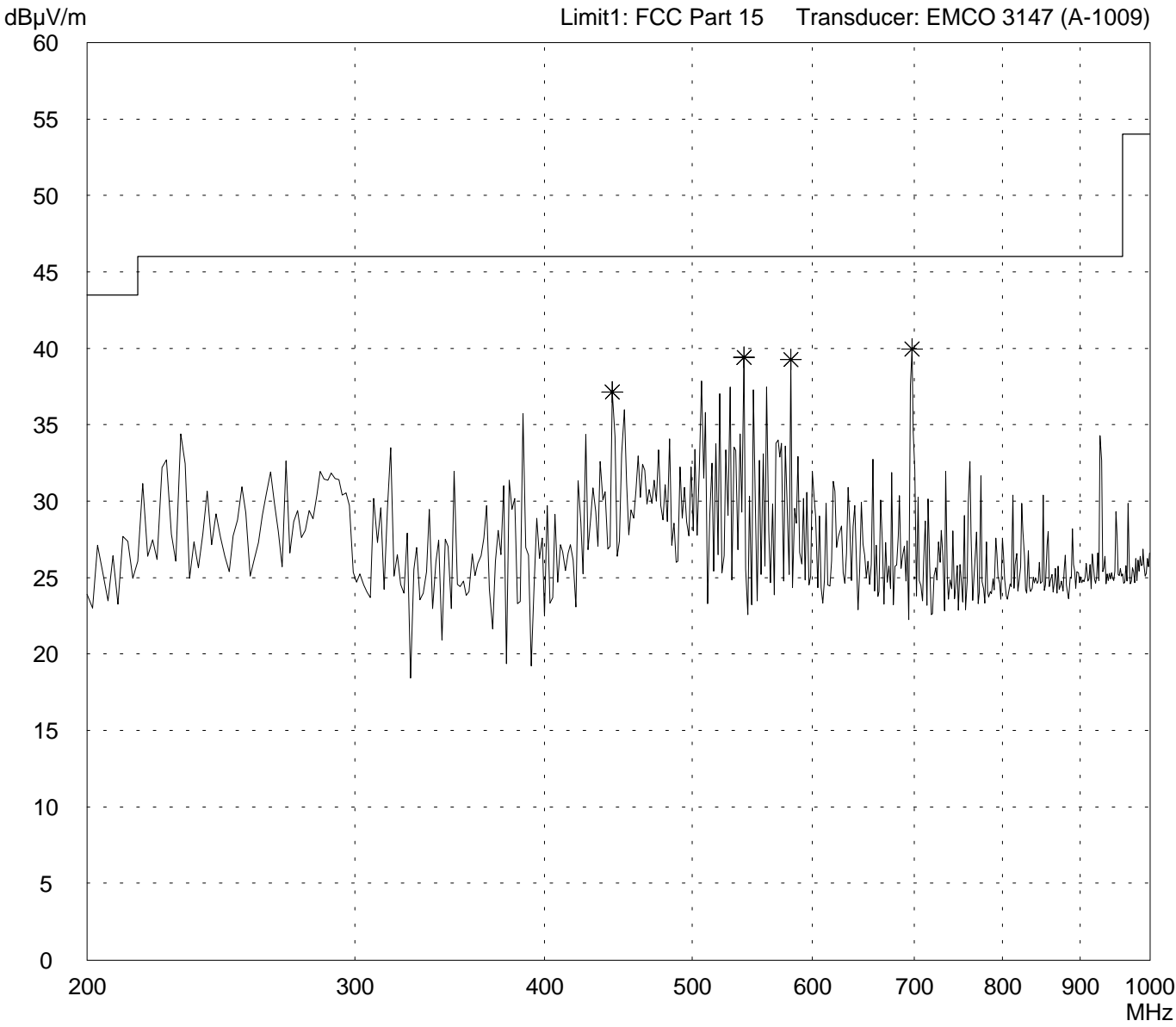

Result: Prescan	Project file: 51905-20108
	Page of Pages

Radiated Emission Test 200 MHz - 1 GHz acc. to FCC Part 15 (Fully Anechoic Chamber)

Model: SLG 75	Comment: - TX mode - FCC test setup - ANT 12
Serial no.: --	
Applicant: Siemens AG, Fürth	
Test site: Fully anechoic room	
Tested on: Test distance 3 metres Vertical Polarization	
Date of test: 07/19/2002	Operator: T. Eberl
Test performed: automatically	File name: default.emi

Detector: Peak	List of values: 10 dB Margin 8 Subranges
--------------------------	---

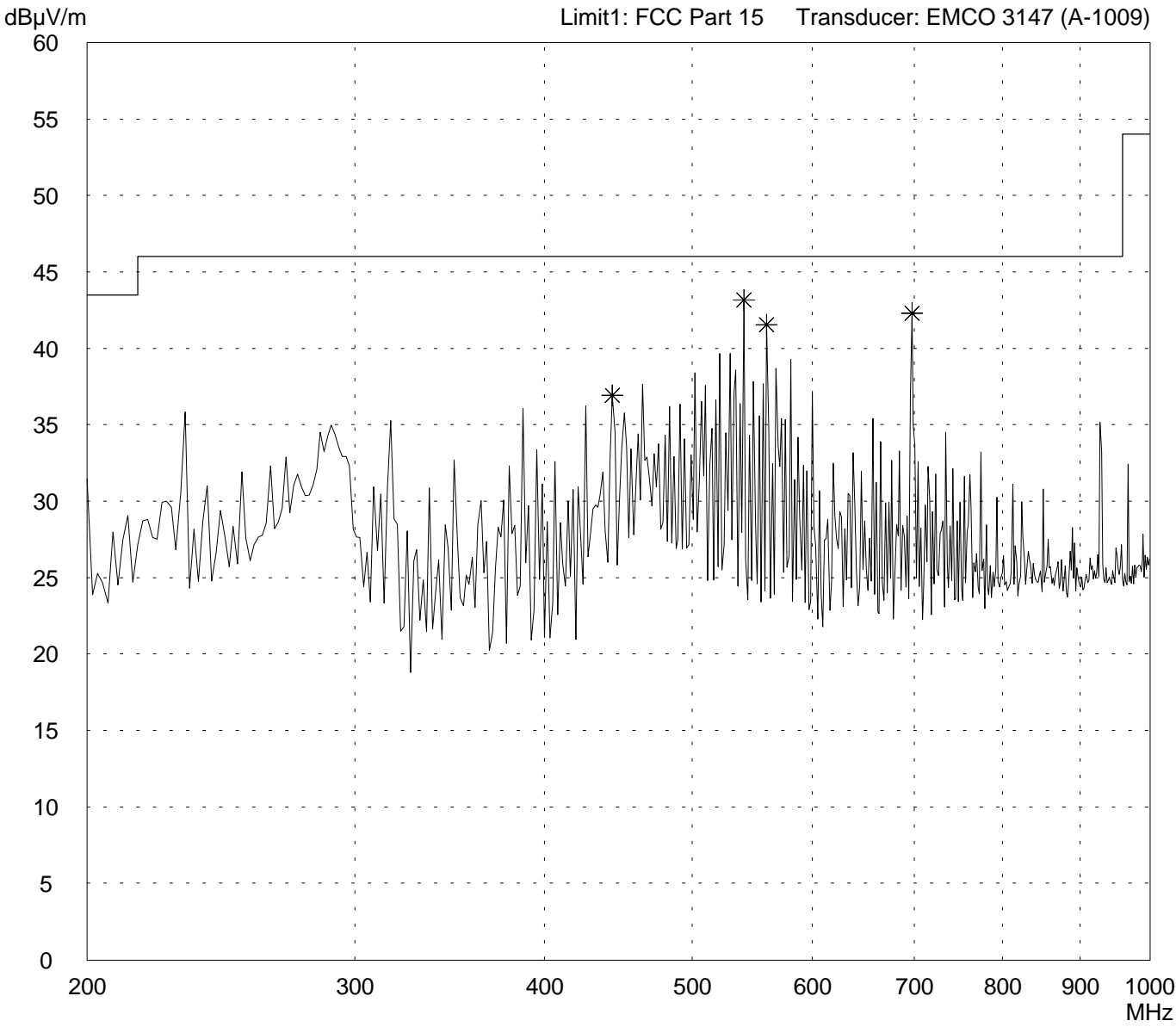

Result: Prescan	Project file: 51905-20108 Page of Pages
---------------------------	--

In Band Emission 13.553 13.567 MHz acc. FCC part 15.225

Model: SLG75	Mode: - TX mode - Value correction to 10 m distance
Serial No.: --	
Applicant: Siemens AG, Fürth	

Ref.Level 83 dBuV
10 dB/Div.

ATT 10 dB

Ref. Offset 13 dB

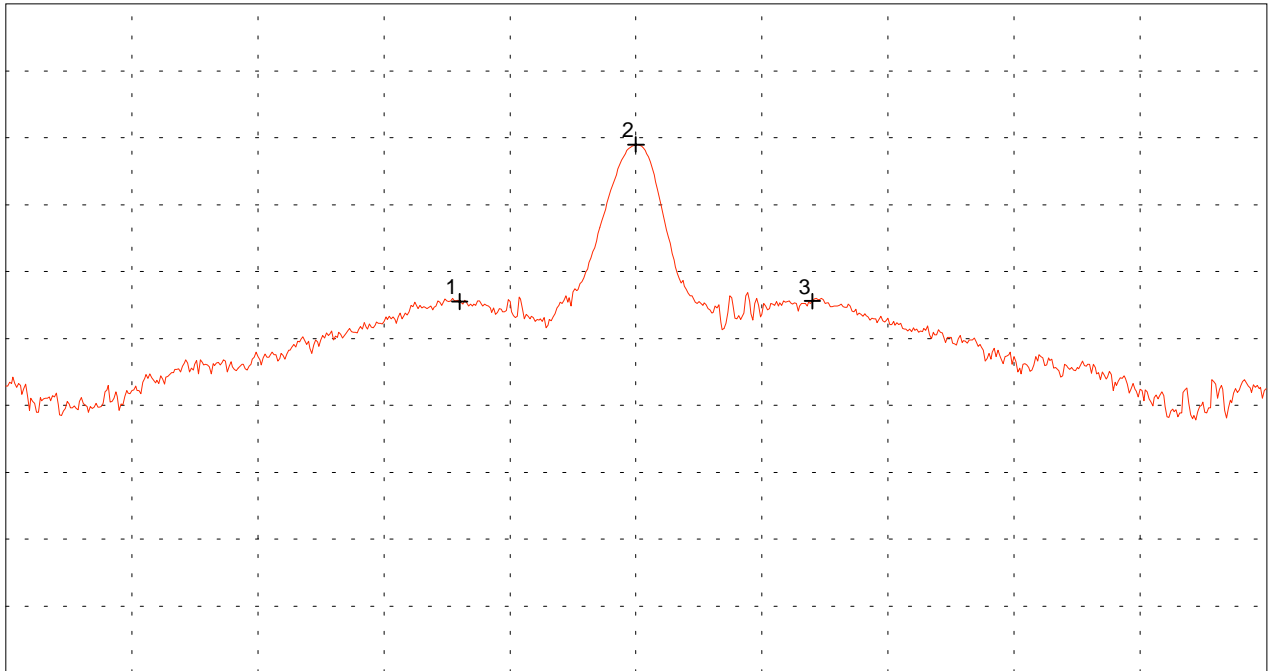

Start 13.535 MHz
RBW 1 kHz

VBW 1 kHz

Stop 13.585 MHz
SWP 130 ms

Multi Marker List			
No. 1	13.553000 MHz	38.53 dBuV	
No. 2	13.560000 MHz	62.00 dBuV	
No. 3	13.567000 MHz	38.59 dBuV	

Tested by: Thomas Eberl
Date: 07/18/2002

Project-No.: 51905-20108
Page of pages

Restricted Band Emission acc. FCC part 15.225

Model: SLG75	Mode: - TX mode - Value correction to 10 m distance
Serial No.: --	
Applicant: Siemens AG, Fürth	

Ref.Level 73 dBuV
5 dB/Div.

ATT 20 dB

Ref. Offset 13 dB

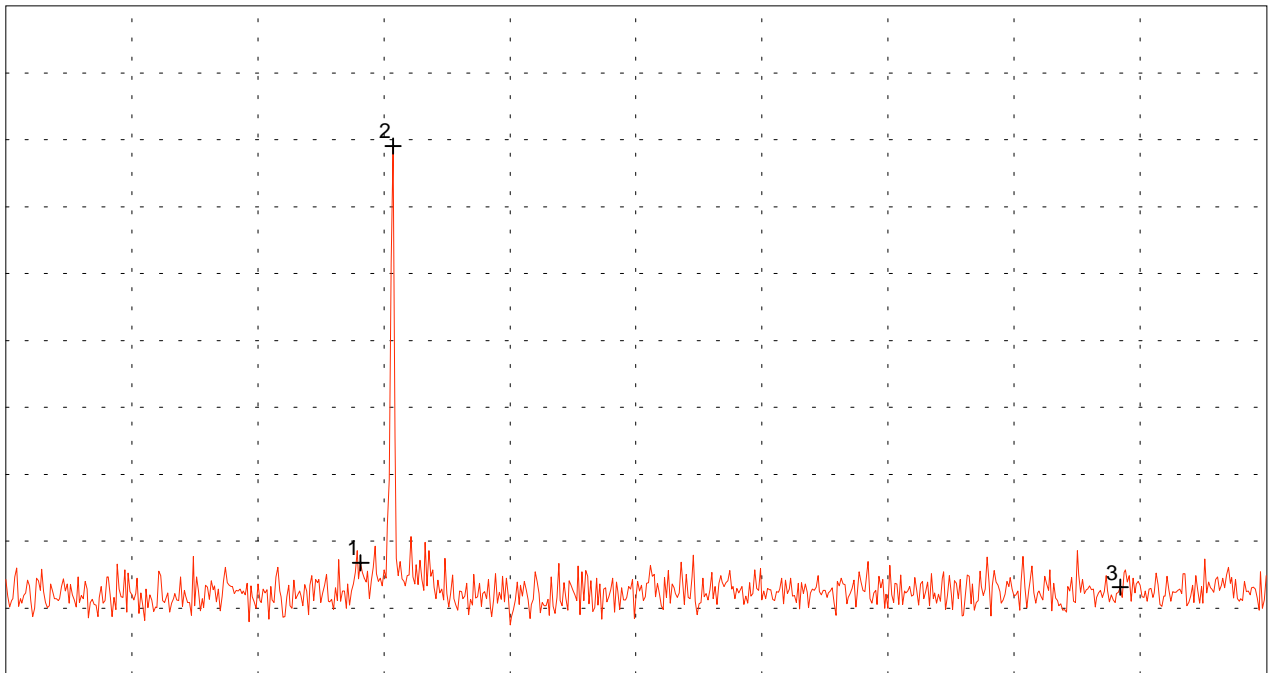

Start 12.000 MHz
RBW 10 kHz

VBW 10 kHz

Stop 17.000 MHz
SWP 160 ms

Multi Marker List

No. 1	13.407000 MHz	31.38 dBuV
No. 2	13.536000 MHz	62.53 dBuV
No. 3	16.421000 MHz	29.56 dBuV

Tested by: Thomas Eberl	Project-No.: 51905-20108
Date: 07/18/2002	Page of pages