

Comment

This cable has an 8-pin M12 connector at one end and the other cable end is 'open'. There are 8 color-coded single cores there for connecting to external devices. There are different cable lengths in the product range (3 m to 50 m). Long cables can be reduced if necessary.

Note

For long cables: Adapt supply voltage and data rate accordingly

Note that with long cables in particular, the supply voltage of 24 V DC must always be applied. Note also that the data rate on the serial interface must, if necessary, be reduced. (See "Configuration Manual RF620R/RF630R")

5.1.1.5 Grounding connection

The RF620R can be electrically connected to the ground potential through a contact washer. The tightening torque must be increased in this case to ensure that electrical contact is made (2.7 Nm).

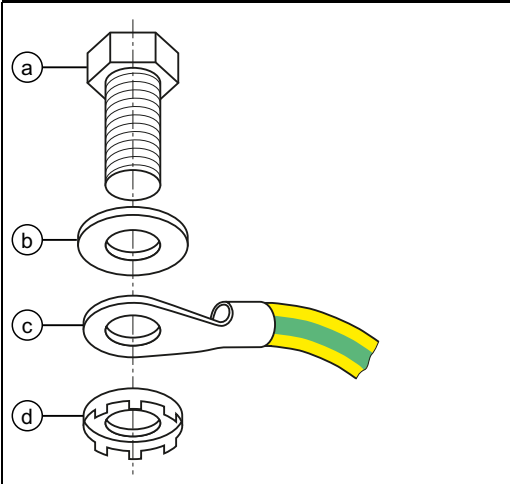
Ground connection	
	(a) Hexagon-head screw
	(b) Plain washer
	(c) Cable lugs
	(d) Contact washer: Use contact washers according to the Siemens standard SN 70093-6-FSt-finnc-480h for ground connection, Siemens item No.: H70093-A60-Z3

5.1.2 Planning application

5.1.2.1 Minimum mounting clearances of two readers

The RF620R has a circular polarized antenna. At 500 mW ERP radiated power, due to the opening angle of the antennas, their fields can overlap considerably. It is no longer possible to clarify in which antenna field access to the data of a tag is performed.

In order to avoid this, always keep a minimum distance of 3 m between two readers with the maximum radiated power of 500 mW ERP.

Dense Reader Mode (DRM)

The readers can also interfere with each other (secondary fields), if the channels (Reader TX, Transponder TX) overlap. In order to prevent a transponder channel overlapping with a reader channel, we recommend that the Dense Reader Mode (DRM) is used.

5.1.2.2 Antenna diagram for RF620R (ETSI)

The following radiation diagrams show the directional radiation pattern of the internal antenna of the RF620R (ETSI) reader. For the spatial presentation of the directional characteristics, the vertical plane (Azimuth section) as well as the horizontal plane (elevation section) must be considered. This results in a spatial image of the directional radiation pattern of the antenna with its main and auxiliary fields.

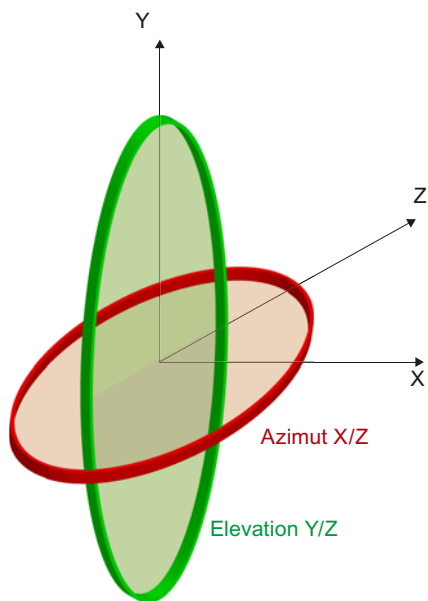

Radiation diagram (Azimuth section)

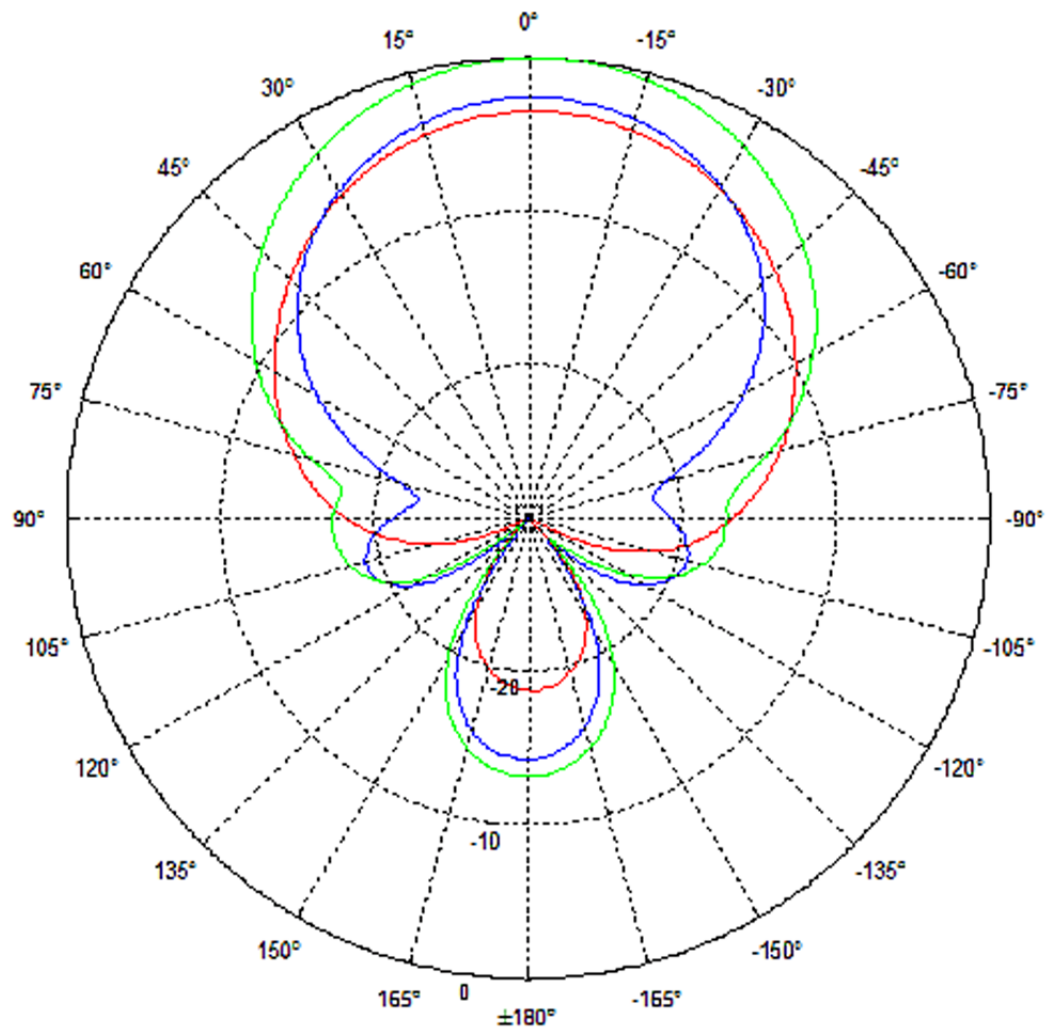

- Vertical component of the polarization direction of the antenna
- Horizontal component of the polarization direction of the antenna
- Right circular component of the polarization direction of the antenna

Figure 5-1 Azimuth section

Radiation diagram (elevation section)

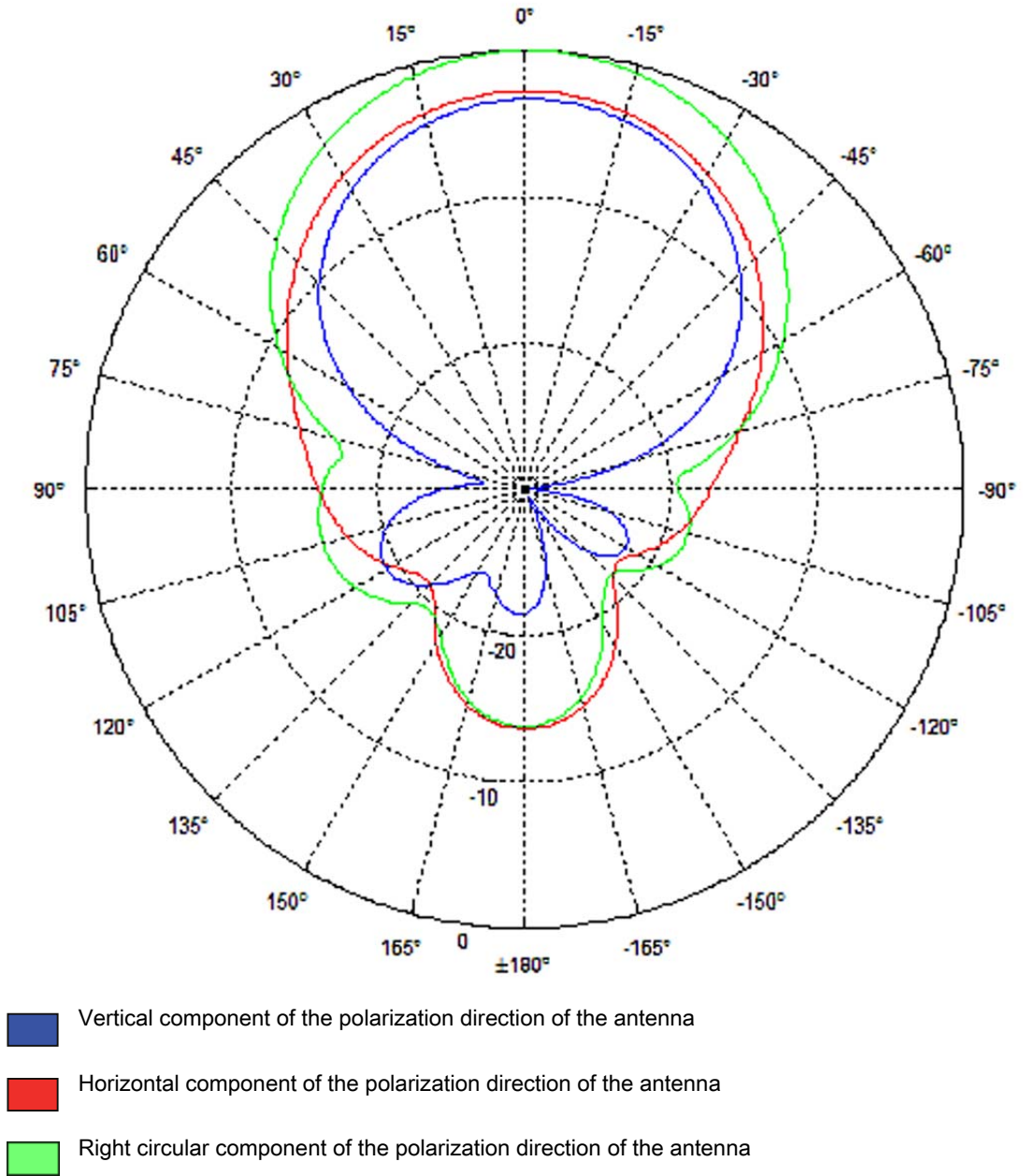

Figure 5-2 Elevation section

Overview of the antenna parameters

Table 5- 2 Maximum linear electrical aperture angle at 865 MHz:

Azimuth section	77,7°
Elevation section	66,1°
Typical antenna gain in the frequency range 865 to 868 MHz	4.0 dBi
Antenna axis ratio	0.7 dB

See also section Guidelines for selecting RFID UHF antennas (Page 54)

5.1.2.3 Antenna diagram for RF620R (FCC)

The following radiation diagrams show the directional radiation pattern of the internal antenna of the RF620R (FCC) reader. For the spatial presentation of the directional characteristics, the vertical plane (Azimuth section) as well as the horizontal plane (elevation section) must be considered. This results in a spatial image of the directional radiation pattern of the antenna with its main and auxiliary fields.

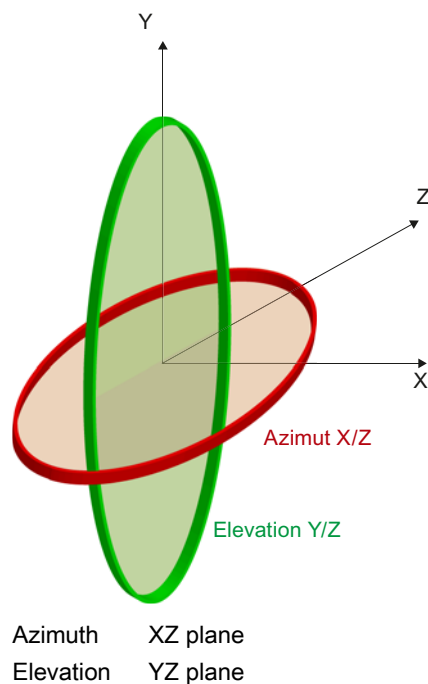

Radiation diagram (Azimuth section)

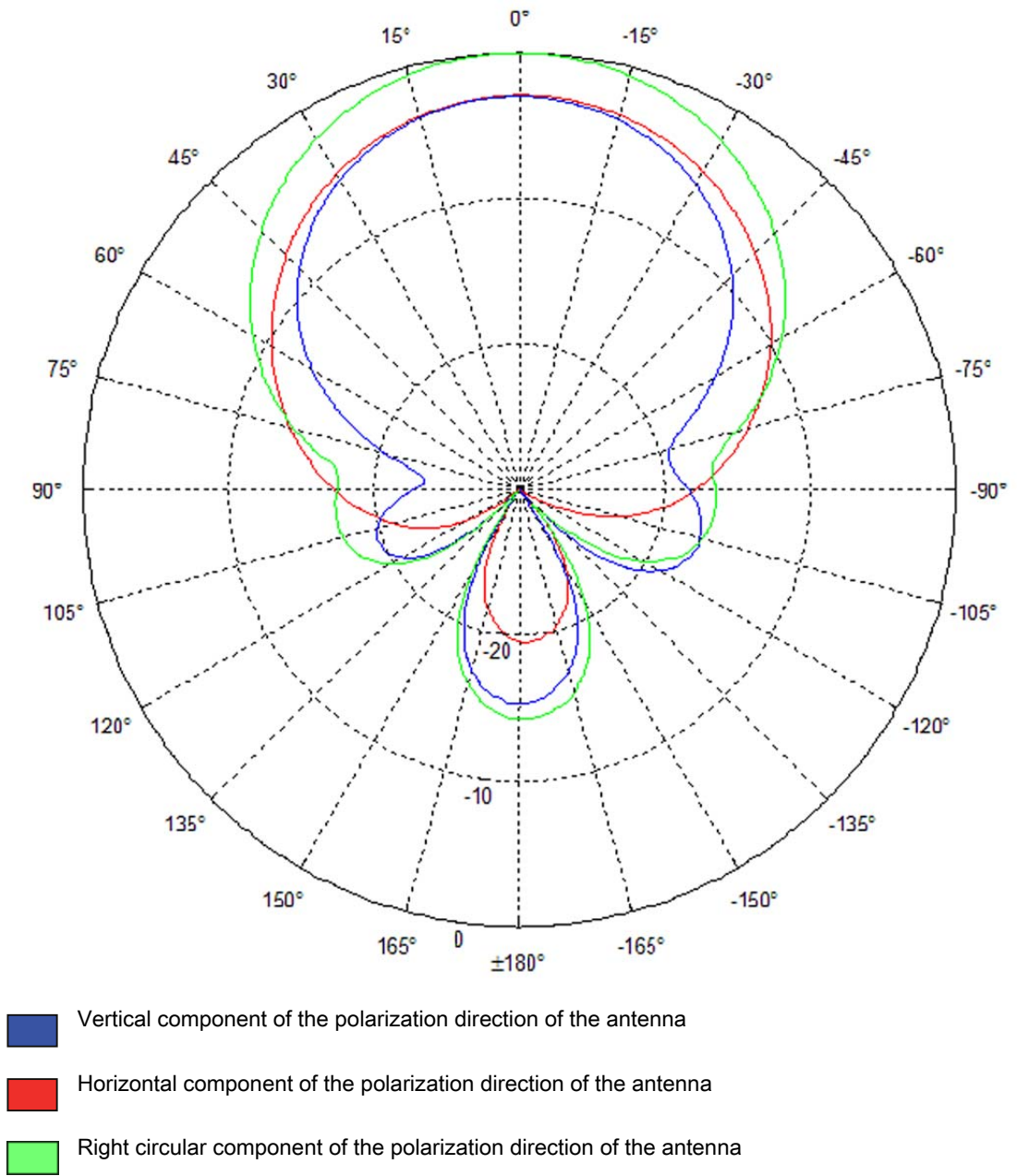
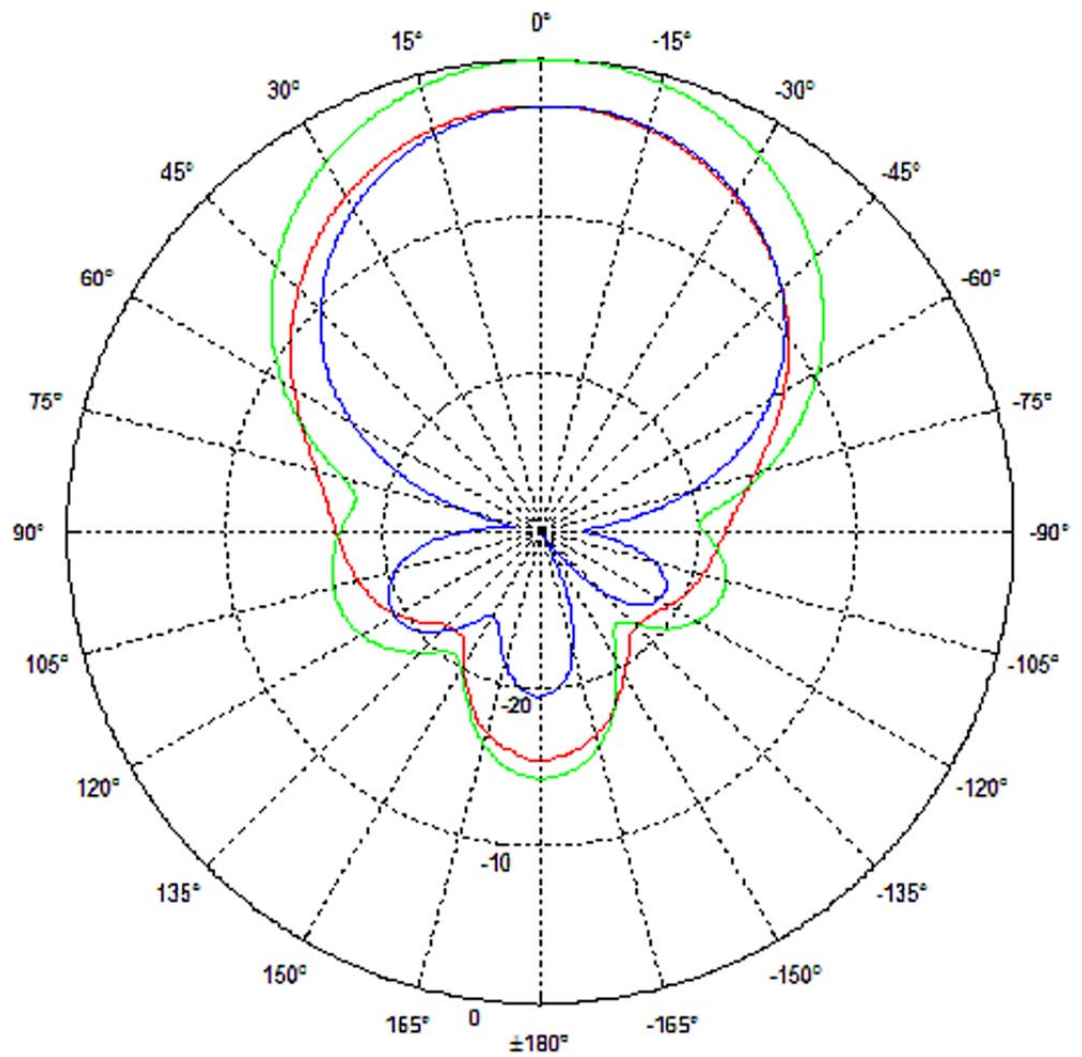

Figure 5-3 Azimuth section

Radiation diagram (elevation section)



- Vertical component of the polarization direction of the antenna
- Horizontal component of the polarization direction of the antenna
- Right circular component of the polarization direction of the antenna

Figure 5-4 Elevation section

Overview of the antenna parameters

Table 5-3 Maximum linear electrical aperture angle at 865 MHz:

Azimuth section	75,4 °
Elevation section	69,1 °
Typical antenna gain in the frequency range 902 to 928 MHz	4.0 dBi ± 0.5 dB
Antenna axis ratio	<1 dB

see also section Guidelines for selecting RFID UHF antennas (Page 54).

5.1.2.4 Interpretation of directional radiation patterns

The following overview table will help you with the interpretation of directional radiation patterns.

The table shows which dBi values correspond to which read/write ranges (in %): You can read the radiated power depending on the reference angle from the directional radiation patterns, and thus obtain information on the read/write range with this reference angle with regard to a transponder.

The dBr values correspond to the difference between the maximum dBi value and a second dBi value.

Deviation from maximum antenna gain [dBr]	Read/write range [%]
0	100
-3	70
-6	50
-9	35
-12	25
-15	18
-18	13

Example

As one can see from the section Antenna diagram for RF620R (ETSI) (Page 100), the maximum antenna gain is 0 dB. In the Azimuth diagram, the antenna gain falls by 3°dB at approximately ± 39°. Therefore the dBr value is -3. The antenna range is only 50% of the maximum range at ± 39° from the Z axis within the horizontal plane.

5.1.2.5 Antenna/read point configurations

The RF620R reader has an internal circular polarized antenna. You can cover one read point with this antenna. When several RF620R readers are used, the readers are addressed via the SIMATIC level.

5.1.3 Installing/Mounting

Requirement

 WARNING

Make sure that the wall or ceiling can hold four times the total weight of the device.

Note**Close unused connectors**

If you do not use connectors on the reader, it is advisable to close the unused connectors with protective caps. You can order the protective cap set using the MLFB specified in the section "Ordering data".

NOTICE**Disregarding FCC RF exposure requirements**

Ensure that the following conditions are met before the device is mounted to meet the FCC RF exposure requirements:

- The RF620R reader must be installed so that a minimum distance from people of 20 cm is always observed.
- The reader may not be installed or operated in the immediate vicinity of another reader or antenna.

See also section FCC information (Page 115) RF620R or section FCC information (Page 131) RF630R.

5.1.3.1 Mounting/Installing FCC

 CAUTION**Emitted radiation**

The transmitter complies with the requirements of Health Canada and the FCC limit values for subjecting persons to HF radiation, provided that a minimum spacing of 26 cm exists between antenna and person. When the antennas are installed, you must therefore ensure that a minimum spacing of 26 cm is maintained between personnel and antennas.

Mounting/installing the device

You can mount the reader in two different ways:

- Via a standardized VESA 100 mounting system using the Antenna Mounting Kit (see Chapter Mounting with antenna mounting kit (Page 262)). Tighten the M4 screws on the rear of the reader using a maximum torque of ≤ 1.3 Nm.
- Directly onto a flat surface.

The positions of the fixing holes for the device are shown in the section Dimension drawings (Page 113).

5.1.4 Configuration/integration

The RS422 system interface is provided for integrating the device into system environments/networks. The system interface transfers data to SIMATIC controllers or PCs with the appropriate interface.

Apart from transmitting communication data from the reader to the controller and vice versa, the RS422 interface also supplies power to the reader (24 V DC).

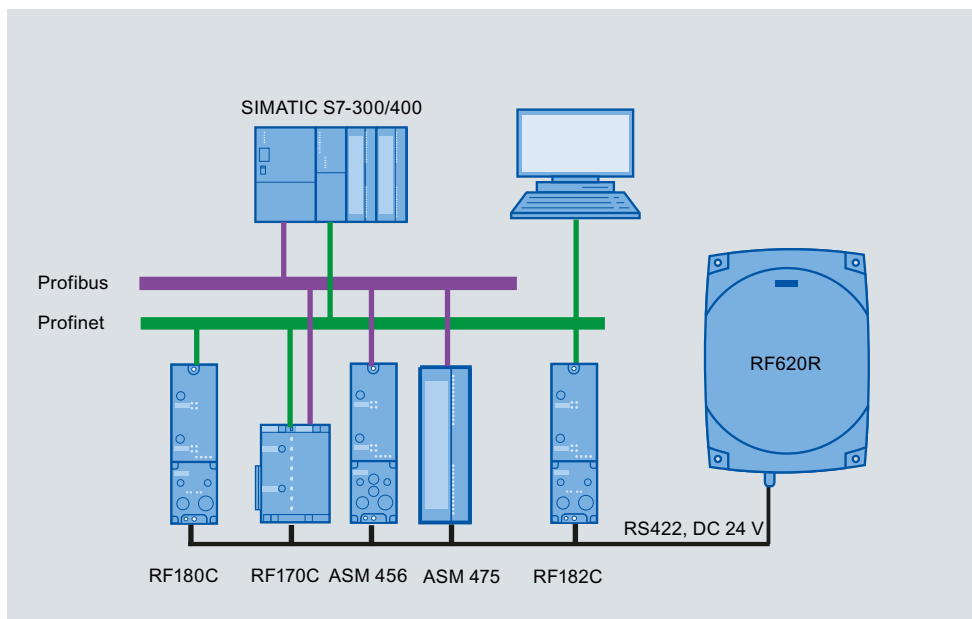

Figure 5-5 Overview of configuration of the RF620R reader

The RF620R reader can alternatively be connected to a SIMATIC controller via the ASM 456, ASM 475, RF170C and RF180C interface modules/communication modules.

The RF620R reader can alternatively also be connected directly to the PC via the RF182 communication module.

For further details on the interface modules used, see Chapter Auto-Hotspot .

Further information about commissioning the readers can be found in the configuration manual "RF620R/RF630R" in the "Commissioning" section.

5.1.4.1 Transmission protocols

RS 422 communication

	3964R protocol
Transmission rates	19.2 kbps 57.6 kbps 115.2 kbps
Start bits	1
Data bits	8
Parity	Odd
Stop bits	1

5.1.5 Technical data

5.1.5.1 Mechanical data

Mechanical data	
Weight	1850 g
Dimensions (L x W x H) in mm	252 X 193 x 52 mm, without connections
Material for housing top section	ABS (GF 20), silicone-free
Material for housing bottom section	Aluminum, silicone-free
Color of housing top section	Pastel turquoise
Color of housing bottom section	Silver
Status displays on the device	1 LED Colors: red, yellow, green
Interfaces	
RS422	1 x plug (8-pin M12)
Antenna connectors	1 x RTNC plug
Software	SIMATIC S7
MTBF in years	18.2

Technical and electrical characteristics			
Power supply		21.6 to 30 VDC ¹	
• Permitted range			
Power supply		Current consumption (in standby mode, no transmit power)	Power consumption (in standby mode, no transmit power)
	20 V input voltage on the reader, typical	135 mA	2.7 W
	24 V input voltage on the reader, typical	115 mA	2.76 W
	30 V input voltage on the reader, typical	95 mA	2.85 W
Power supply		Current consumption (at 500 mW ERP)	Power requirement (at 500 mW ERP)
	20 V input voltage on the reader, typical	470 mA	9.4 W
	24 V input voltage on the reader, typical	395 mA	9.48 W
	30 V input voltage on the reader, typical	320 mA	9.6 W
Ramp-up time, typical		7 s	

¹⁾ All supply and signal voltages must be safety extra low voltage (SELV/PELV according to EN 60950)

24 VDC supply: safe (electrical) isolation of extra-low voltage (SELV / PELV acc. to EN 60950)

Mechanical environmental conditions	
Shock resistant acc. to EN 60068-2-27	50 g ¹
Vibration acc. to EN 60068-2-6	20 g ¹
Climatic conditions	
Ambient temperature during operation	-25 °C to +55 °C (a 10-minute warm-up time must be allowed at an operating temperature below -20 °C)
Ambient temperature for transport and storage	-40 °C to +85 °C

¹⁾ The values for shock and vibration are maximum values and must not be applied continuously.

EMC & approvals/conformity RF620R (ETSI)	
Electromagnetic compatibility	ETSI EN 301 489-1 / -3
	ETSI EN 302 208 V1.3.1
	ETSI EN 302 208 V1.4.1
Approvals/Conformity	<ul style="list-style-type: none"> • Radio acc. to R&TTE guidelines, EN 301 489 • CE • ETSI EN 302-208 V1.1.1 • ETSI EN 302-208 V1.3.1 • ETSI EN 302-208 V1.4.1 • Reader degree of protection acc. to EN 60529 (IP65)

EMC & approvals for FCC variant	
Electromagnetic compatibility	FCC Part 15
Approvals	<ul style="list-style-type: none"> • FCC, cULus • IEC60950, including US and Canadian variants of it • FCC CFR47 Part 15.247 • RoHS-compliant according to EU Directive 2002/95/EC • Industrial Canada, RSS-210, Issue 7, June 2007

5.1.5.2 Technical data according to EPC and ISO

Technical specifications	
Frequency accuracy	max.± 10 ppm
Channel spacing	EU, EFTA, Turkey: 200 kHz US: 500 kHz China: 250 kHz
Modulation methods	ASK: DSB modulation & PR-ASK modulation Encoding, Manchester or Pulse Interval (PIE)
Effective radiated power with internal antenna <ul style="list-style-type: none"> • ETSI/CMIIT: • FCC 	<ul style="list-style-type: none"> • ≤ 0.8 W ERP • ≤ 1.3 W EIRP
Effective radiated power with external antenna <ul style="list-style-type: none"> • ETSI/CMIIT: • FCC 	<ul style="list-style-type: none"> • ≤ 1.2 W ERP • ≤ 2.0 W EIRP
Transmit power	≤ 0.5 W

Reading range	
Readers mounted on the same side	Max. 2 m (recommended maximum value for configuration; depending on the transponder)

ETSI frequencies	
Frequency range for Europe, EFTA, Turkey, South Africa ETSI EN 302 208 V1.3.1 (valid since August 10, 2010, publication in the Official Journal of the European Union)	865,7 ... 867.5 MHz (4 channels LBT optional at max. 2 W ERP)
Frequency range India	865 ... 860 MHz (10 channels at max. 4 W EIRP)
Frequency range Russia	866 ... 867 MHz (8 channels at 2 W ERP)
Frequency range Singapore	866 ... 869 MHz (11 channels at 0.5 W ERP)

FCC frequencies	
Frequency range USA; Argentina, Bolivia, Canada, Mexico	902 ... 928 MHz (50 channels at max. 4 W EIRP, frequency hopping)
Frequency range Brazil	515,25 ... 527.75 MHz (26 channels at max. 4 W EIRP, frequency hopping)
Frequency range South Korea	917,3 ... 920.3 MHz (7-16 channels at max. 4 W EIRP, frequency hopping)
Frequency range Thailand	920.25 ... 924.75 MHz (10 subchannels at max. 4 W ERP, frequency hopping)

Frequencies CMIIT	
Frequency range China	920,625 ... 924.375 MHz (16 subchannels at 2 W ERP)

5.1.5.3 Maximum number of readable tags

The maximum number of readable tags depends on the following parameters:

- Size of the antenna field
- Readability of the tags

For a transmit power of 500 mW ERP, the following is read when the tag RF620T is used:

- Max. 40 tags in the antenna field (tags perpendicular to antenna and 1 m in front)
- Max. 18 tags per second

5.1.6 Dimension drawings

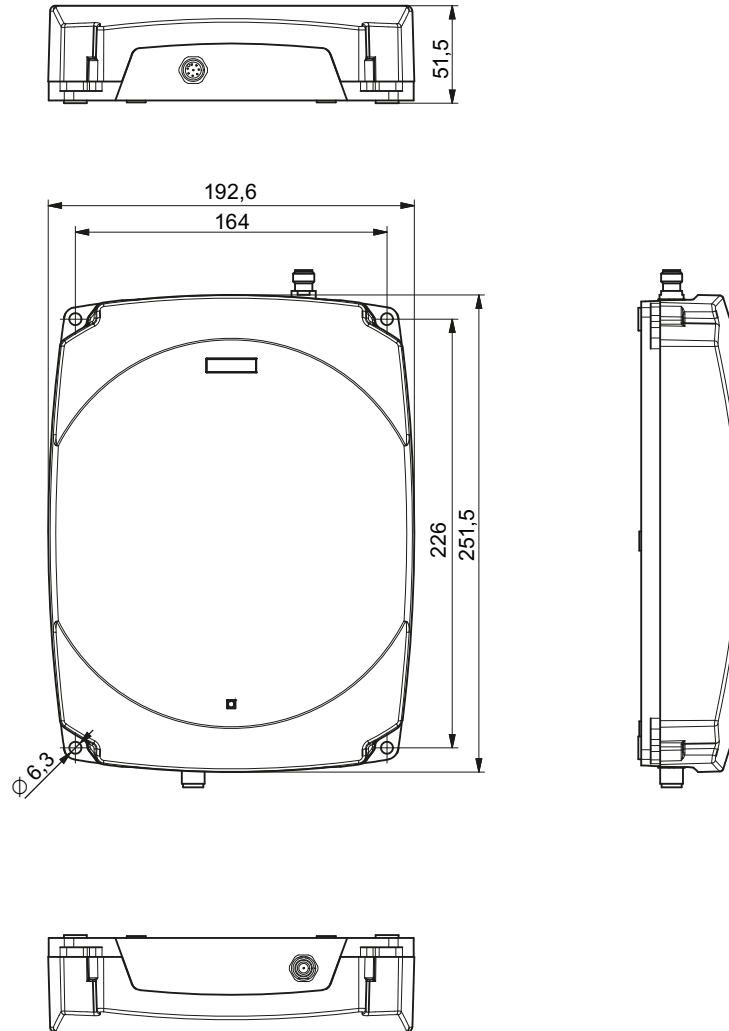

Figure 5-6 Dimension drawing for RF620R

All dimensions in mm (± 0.5 mm tolerance)

5.1.7 Certificates and approvals

Note

Marking on the readers according to specific approval

The certificates and approvals listed here apply only if the corresponding mark is found on the readers.

Table 5- 4 6GT2811-5BA00-0AA0, 6GT2811-5BA00-0AA1

Certificate	Description
	Conformity with R&TTE directive

5.1.7.1 Country-specific certifications

Table 5- 5 6GT2811-5BA00-1AA0, 6GT2811-5BA00-1AA1



Standard	
 Federal Communications Commission	FCC CFR 47, Part 15 sections 15.247 Radio Frequency Interference Statement This equipment has been tested and found to comply with the limits for a Class B digital device, pursuant to Part 15 of the FCC Rules. FCC ID: NXW-RF620R (for 6GT2811-5BA00-1AA0) FCC ID: NXW-RF600R (for 6GT2811-5BA00-1AA1)
Industry Canada Radio Standards Specifications	RSS-210 Issue 7, June 2007, Sections 2.2, A8 IC: 267X-RF620R (for 6GT2811-5BA00-1AA0) IC: 267X-RF600R, Model RF620R-2 (for 6GT2811-5BA00-1AA1)
	This product is UL-certified for the USA and Canada. It meets the following safety standard(s): UL 60950-1 - Information Technology Equipment Safety - Part 1: General Requirements CSA C22.2 No. 60950 -1 - Safety of Information Technology Equipment UL Report E 205089

Table 5- 6 6GT2811-5BA00-2AA1

Standard	
CMIIT Certification	China radio approval Marking on the reader: CMIIT ID:

5.1.7.2 FCC information

Siemens SIMATIC RF620R (FCC): 6GT2811-5BA00-1AA0, 6GT2811-5BA00-1AA1

FCC ID: NXW-RF620R (for 6GT2811-5BA00-1AA0)

FCC ID: NXW-RF600R (for 6GT2811-5BA00-1AA1)

This device complies with part 15 of the FCC rules.

Operation is subject to the following two conditions:

- (1) This device may not cause harmful interference, and
- (2) This device must accept any interference received, including interference that may cause undesired operation.

Caution

Any changes or modifications not expressly approved by the party responsible for compliance could void the user's authority to operate the equipment.

Note

This equipment has been tested and found to comply with the limits for a Class B digital device, pursuant to part 15 of the FCC Rules. These limits are designed to provide reasonable protection against harmful interference when the equipment is operated in a commercial environment. This equipment generates, uses, and can radiate radio frequency energy and, if not installed and used in accordance with the instruction manual, may cause harmful interference to radio communications. Operation of this equipment in a residential area is likely to cause harmful interference in which case the user will be required to correct the interference at his own expense.

FCC Notice

To comply with FCC part 15 rules in the United States, the system must be professionally installed to ensure compliance with the Part 15 certification.

It is the responsibility of the operator and professional installer to ensure that only certified systems are deployed in the United States. The use of the system in any other combination (such as co-located antennas transmitting the same information) is expressly forbidden.

FCC Exposure Information

To comply with FCC RF exposure compliance requirements, the RF620R Reader (antenna and transmitter) must be installed to provide a separation distance of at least 20 cm from all persons and must not be co-located or operating in conjunction with any other antenna or transmitter.

5.1.7.3 IC-FCB information

Siemens SIMATIC RF620R (FCC): 6GT2811-5BA00-1AA0, 6GT2811-5BA00-1AA1

IC: 267X-RF620R (for 6GT2811-5BA00-1AA0)

IC: 267X-RF600R, Model: RF620R-2 (for 6GT2811-5BA00-1AA1)

Industry Canada Notice

To reduce potential radio interference to other users, the antenna type and its gain should be so chosen that the equivalent isotropically radiated power (e.i.r.p.) is not more than that permitted for successful communication.

Transmitter power and antenna information for antennas with a gain less than 6 dBi:

This device has been designed to operate with the SIMATIC RF620A antenna 902-928, the SIMATIC RF640A antenna 902-928 as well as the SIMATIC RF660A antenna 902-928 listed below, and having a maximum gain of 5,5 dBi. Arbitrary transmission power settings in combination with other antennas or antennas having a gain greater than 5,5 dBi are strictly prohibited for use with this device. The required antenna impedance is 50 Ohms.

Transmitter power and antenna information for antennas with a gain greater 6 dBi:

This device requires professional installation. Antennas with a gain greater 6 dBi may be used provided the system does not exceed the radiation power of 4000 mW E.I.R.P. This device has been designed to operate with the SIMATIC RF642A antenna 902-928 exceeding the maximum gain of 5,5 dBi under the restriction that the RF power at the input of the antenna must be set to meet the following relation: $\text{RF power (dBm)} \leq 30 \text{ dBm} - (\text{antenna gain (dBi)} - 6 \text{ dBi})$ Other antennas or system configurations for antennas having a gain greater than 6 dBi are strictly prohibited for use with this device. The required antenna impedance is 50 Ohms.

5.2 RF630R reader

5.2.1 Description

The SIMATIC RF630R is an active stationary reader in the UHF frequency range without an integrated antenna. Up to two external UHF RFID antennas can be connected via TNC reverse connections.

The maximum HF power output is 0.5 W on the reader output. The SIMATIC RF630R is connected to a SIMATIC S7 controller via an ASM interface module. The degree of protection is IP65.

	Pos.	Description
	(1)	TNC reverse interface for connection of antenna 1 (ANT 1)
	(2)	TNC reverse interface for connection of antenna 2 (ANT 2)
	(2)	LED status indicator
	(3)	RS 422 interface (8-pin M12 connector)

Highlights

- The tags are read in accordance with the requirements of the EPCglobal Class 1, Gen 2 and ISO/IEC 18000-6C standards
- Supports low-cost SmartLabels as well as reusable, rugged data media
- High reading speed: Depending on the function block (multitag mode), many tags can be detected simultaneously (bulk reading), rapidly moving tags are reliably acquired.
- The RF630R (ETSI) "6GT2811-4AA00-0AAx" is suitable for the frequency band 865 to 868 MHz UHF (EU, EFTA, Turkey). The reader supports the standard ETSI EN 302 208 V1.2.1 (4-channel plan).
- The RF630R (FCC) "6GT2811-4AA00-1AAx" is suitable for 902 to 928 MHz.

- The RF630R (CMIIT) "6GT2811-4AA00-2AA1" is suitable for the frequency band 920.125 to 924.875 MHz (China).
- Up to 2 external antennas can be connected and configured in operating mode
- IP65 degree of protection for reader
- Can be used for a high temperature range
- Dense Reader Mode (DRM) for environments in which many readers are operated in close proximity to each other
- TIA system interface:
 - RS 422

5.2.1.1 Ordering data

Ordering data for RF630R

Product	Order number
RF630R (ETSI) reader for EU, EFTA, Turkey	6GT2811-4AA00-0AA0 6GT2811-4AA00-0AA1
RF630R (FCC) reader for the USA	6GT2811-4AA00-1AA0 6GT2811-4AA00-1AA1
RF630R (CMIIT) reader for China	6GT2811-4AA00-2AA1

Ordering data for antennas and antenna cables

Product	Order number
Antennas <ul style="list-style-type: none"> • RF620A antenna for EU, EFTA, Turkey (868 MHz) • RF620A antenna for China and USA (915 MHz) • RF640A antenna (865 to 928 MHz) • RF642A antenna (865 to 928 MHz) • RF660A antenna for EU, EFTA, Turkey (868 MHz) • RF660A antenna for China and USA (915 MHz) 	<ul style="list-style-type: none"> • 6GT2812-1EA00 • 6GT2812-1EA01 • 6GT2812-0GA08 • 6GT2812-1GA08 • 6GT2812-0AA00 • 6GT2812-0AA01
Antenna cable <ul style="list-style-type: none"> • 3 m (cable attenuation: 1.0 dB) • 5 m (cable attenuation: 1.25 dB, suitable for drag chains) • 10 m (cable attenuation: 2.0 dB) • 10 m (cable attenuation: 4.0 dB) • 15 m (cable attenuation: 4.0 dB, suitable for drag chains) • 20 m (cable attenuation: 4.0 dB) 	<ul style="list-style-type: none"> • 6GT2815-0BH30 • 6GT2815-2BH50 • 6GT2815-1BN10 • 6GT2815-0BN10 • 6GT2815-2BN15 • 6GT2815-0BN20

Ordering data (accessories)

Product	Order number
Connecting cable <ul style="list-style-type: none"> • RS°422, M12 plug, 8-pin socket: 2 m • RS°422, M12 plug, 8-pin socket: 5 m • RS°422, M12 plug, 8-pin socket: 10 m • RS°422, M12 plug, 8-pin socket: 20 m • RS°422, M12 plug, 8-pin socket: 50 m 	<ul style="list-style-type: none"> • 6GT2891-0FH20 • 6GT2891-0FH50 • 6GT2891-0FN10 • 6GT2891-0FN20 • 6GT2891-0FN50
Antenna mounting kit	6GT2890-0AA00
Set of protective caps Contains 3 protective caps for antenna output and one protective cap for digital I/O interface (required for IP65 degree of protection when some connectors are unused)	6GT2898-4AA00
RFID DVD "Software & Documentation"	6GT2080-2AA20

5.2.1.2 Status display

The device is equipped with a three colored LED. The LED can be lit in green, red or yellow. The meaning of the indication changes in accordance with the color and state (on, off, flashing) of the LED:

Green LED	Red LED	Yellow LED	Meaning
Off	Off	Off	The device is starting up.
Flashing	Off	Off	The device is ready. The antenna is switched off.
On	Off	Off	The device is ready. The antenna is switched on.
Off	Off	On	"With presence": At least one tag is in the field. "Without presence": Communication with a tag is active.
Off	Flashing	Off	Reader is not active, a serious error has occurred. In addition, this LED also indicates the fault status through the number of flashing pulses. Reboot (operating voltage Off → On is necessary). The LED flashes once for the 'INACTIVE' status, rebooting is not necessary in this case.

For more detailed information on the flash codes of the reader see section Error messages and flash codes for RF620R/RF630R (Page 386)

Note

LED not lit yellow?

If the LED does not light up yellow even though a tag is located within the field, common causes are:

- Incorrect configuration in the init_run command, or init_run command was not executed (see "Configuration Manual RF620R/RF630R")
- Parameter assignment is incorrect (black list, RSSI threshold)
- Antenna is switched off
- A tag is used, that is not compatible with the reader protocol (EPC Global Class 1 Gen 2).
- Tag is defective
- Reader or antenna has a defect
- Tag is not in the field of radiation of the transmit antenna

5.2.1.3 Pin assignment of the RS422 interface

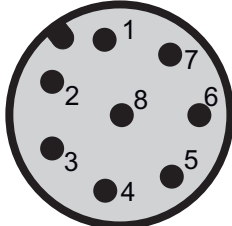
Pin	Pin Device end 8-pin M12	Assignment
	1	+ 24 V
	2	- Transmit
	3	0 V
	4	+ Transmit
	5	+ Receive
	6	- Receive
	7	Free
	8	Earth (shield)

The knurled bolt of the M12 plug is not connected to the shield (on the reader side).

Note

You must therefore not use any SIMATIC connecting cables that use the angled M12 plug.

5.2.1.4 Pin assignment of the connecting cable

Table 5- 7 RS 422 - on reader side

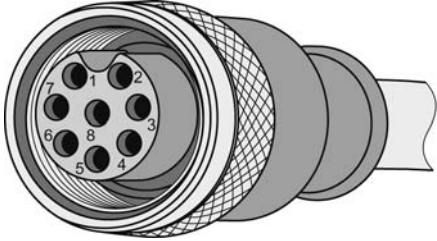
M12 pin	Core color	Pin assignment	View of M12 socket
1	white	24 VDC	
2	brown	TX neg	
3	green	GND	
4	yellow	TX pos	
5	Gray	RX pos	
6	pink	RX neg	
7	blue	Not assigned	
8	red	Earth (shield)	

Comment

This cable has an 8-pin M12 connector at one end and the other cable end is 'open'. There are 8 color-coded single cores there for connecting to external devices. There are different cable lengths in the product range (3 m to 50 m). Long cables can be reduced if necessary.

Note

For long cables: Adapt supply voltage and data rate accordingly

Note that with long cables in particular, the supply voltage of 24 V DC must always be applied. Note also that the data rate on the serial interface must, if necessary, be reduced. (See "Configuration Manual RF620R/RF630R")

5.2.1.5 Grounding connection

The RF630R can be electrically connected to the ground potential through a contact washer. The tightening torque must be increased in this case to ensure that electrical contact is made (2.7 Nm).

WARNING

Hazardous voltage due to lightning strikes

Death or serious injury may occur as a result of lightning strikes to antennas mounted outside buildings.

If the reader is operated with antennas mounted outside buildings, it is imperative that the reader is electrically connected to the ground potential.

Ground connection	
	(a) Hexagon-head screw
	(b) Plain washer
	(c) Cable lug
	(d) Contact washer: Use contact washers according to the Siemens standard SN 70093-6-FSt-flNnnc-480h for ground connection, Siemens item No.: H70093-A60-Z3

5.2.2 Planning application

5.2.2.1 Minimum mounting clearances of two antennas of different readers

At 500 mW ERP radiated power, due to the opening angle of the antennas, their fields can overlap considerably. It is no longer possible to clarify in which antenna field access to the data of a tag is performed.

In order to avoid this, always keep a minimum distance of 3 m between two antennas of different RF630R readers with the maximum radiated power of 500 mW ERP.

Dense Reader Mode (DRM)

The readers can also interfere with each other (secondary fields), if the channels (Reader TX, Transponder TX) overlap. In order to prevent a transponder channel overlapping with a reader channel, we recommend that the Dense Reader Mode (DRM) is used.

5.2.2.2 Antenna/read point configurations

You can connect up to two external antennas to the RF630R reader. The standard setting is that two antennas are connected when the reader is started.

You have 3 possibilities for aligning the antennas and covering the read point.

One RF630R reader with two antennas and two read points

If you connect two external antennas to the device and align them in different directions, you can read tags at two different read points. With this technique, a particular antenna must be switched off application-dependently to be able to establish which tags have been read from which antenna. Note the minimum distances between the antennas for the antenna configuration (see section Specified minimum and maximum spacing of antennas (Page 45)) .

One RF630R reader with two antennas and one read point

If you connect two external antennas to the device and align them in the same direction (portal configuration), you can read tags at one read point. With this method, the reader automatically switches between the two antennas while the tags are being read. Note the minimum distances between the antennas for the antenna configuration (see section Specified minimum and maximum spacing of antennas (Page 45)) .

One RF630R reader with one antenna and one read point

If you connect an external antenna to the device, you can read tags at one read point.

5.2.3 Installing/Mounting

5.2.3.1 Mounting/Installation

Requirement

 WARNING
--

Make sure that the wall or ceiling can hold four times the total weight of the device.
--

Note

Close unused connectors

If you do not use connectors on the reader, it is advisable to close the unused connectors with protective caps. You can order the protective cap set using the MLFB specified in the section "Ordering data".

CAUTION
Emitted radiation
The transmitter complies with the requirements of Health Canada and the FCC limit values for subjecting persons to HF radiation, provided that a minimum spacing of 26 cm exists between antenna and person. When the antennas are installed, you must therefore ensure that a minimum spacing of 26 cm is maintained between personnel and antennas.

Mounting/installing the device

You can mount the reader directly onto a flat surface.

The positions of the fixing holes for the device are shown in the section Dimension drawings (Page 129).

5.2.4 Configuration/integration

The RS422 system interface is provided for integrating the device into system environments/networks. The system interface transfers data to SIMATIC controllers or PCs with the appropriate interface.

Apart from transmitting communication data from the reader to the controller and vice versa, the RS422 interface also supplies power to the reader (24 V DC).

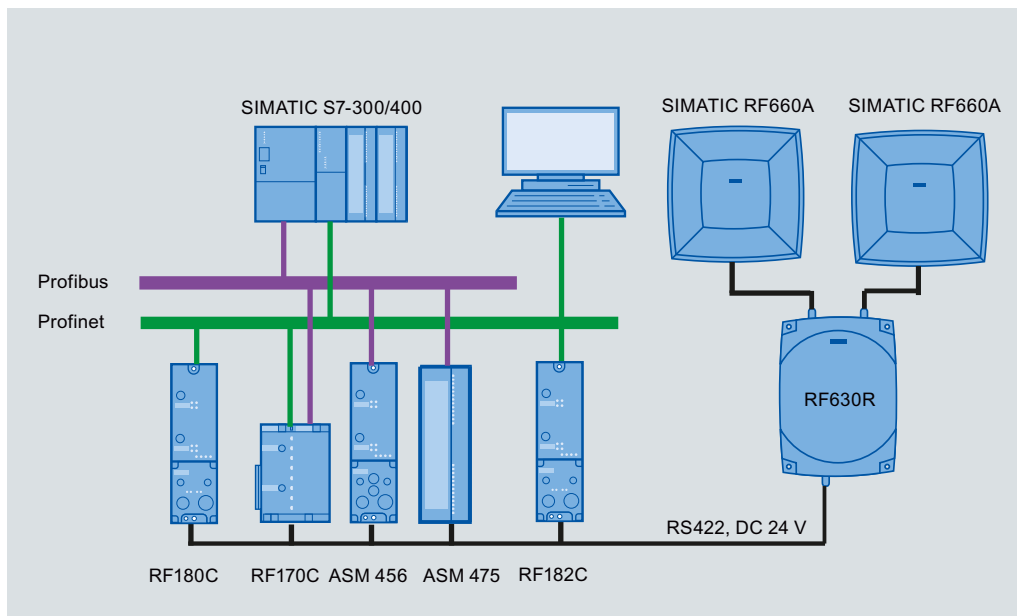

Figure 5-7 Overview of configuration of the RF630R reader

The RF620R reader can alternatively be connected to a SIMATIC controller via the ASM 456, ASM 475, RF170C and RF180C interface modules/communication modules.

The RF620R reader can alternatively also be connected directly to the PC via the RF182 communication module.

For further details on the interface modules used, see Chapter Auto-Hotspot .

Further information about commissioning the readers can be found in the Configuration Manual "RF620R/RF630R" in the "Commissioning" section.

5.2.4.1 Transmission protocols

RS 422 communication

	3964R protocol
Transmission rates	19.2 kbps 57.6 kbps 115.2 kbps
Start bits	1
Data bits	8
Parity	Odd
Stop bits	1

5.2.5 Technical data

5.2.5.1 Mechanical data

Mechanical data	
Weight	1640 g
Dimensions (L x W x H) in mm	252 x 193 x 52 mm, without connections
Material for housing top section	ABS (GF 20)
Material for housing bottom section	Aluminum
Color of housing top section	Anthracite
Color of housing bottom section	Silver
Status displays on the device	1 LED Colors: red, yellow, green
Interfaces	
Antenna connectors	2 x RTNC plug
RS422	1 x plug (8-pin M12)
Software	SIMATIC S7
MTBF in years	18.2

Thermal and electrical properties			
Power supply		21.6 to 30 VDC ¹	
<ul style="list-style-type: none"> Permitted range 			
Power supply		Current consumption (in standby mode, no transmit power)	Current consumption (in standby mode, no transmit power)
	20 V input voltage on the reader, typical	135 mA	2.7 W
	24 V input voltage on the reader, typical	115 mA	2.76 W
	30 V input voltage on the reader, typical	95 mA	2.85 W
Power supply		Current consumption (at 500 mW ERP)	Power requirement (at 500 mW ERP)
	20 V input voltage on the reader, typical	470 mA	9.4 W
	24 V input voltage on the reader, typical	395 mA	9.48 W
	30 V input voltage on the reader, typical	320 mA	9.6 W
Rampup time		7 s	

¹⁾ All supply and signal voltages must be safety extra low voltage (SELV/PELV according to EN 60950)

24 VDC supply: safe (electrical) isolation of extra-low voltage (SELV / PELV acc. to EN 60950)

Mechanical environmental conditions	
Shock resistant acc. to EN 60068-2-27	50 g ¹
Vibration acc. to EN 60068-2-6	20 g ¹
Climatic conditions	
Ambient temperature during operation	-25 °C to +55 °C (a 10-minute warm-up time must be allowed at an operating temperature below -20 °C)
Ambient temperature for transport and storage	-40 °C to +85 °C

¹⁾ The values for shock and vibration are maximum values and must not be applied continuously.

EMC & approvals/conformity for ETSI variant	
Electromagnetic compatibility	ETSI EN 301 489-1 / -3
	ETSI EN 302 208 V1.3.1 ETSI EN 302 208 V1.4.1
Approvals/Conformity	<ul style="list-style-type: none"> Radio acc. to R&TTE guidelines, EN 301 489 CE ETSI EN 302-208 V1.1.1 ETSI EN 302-208 V1.3.1 ETSI EN 302-208 V1.4.1 Reader degree of protection acc. to EN 60529 (IP65)

EMC & approvals for FCC variant	
Electromagnetic compatibility	FCC Part 15
Approvals	<ul style="list-style-type: none"> • FCC, cULus • IEC60950, including US and Canadian variants of it • FCC CFR47 Part 15.247 • RoHS-compliant according to EU Directive 2002/95/EC • Industrial Canada, RSS-210, Issue 7, June 2007

5.2.5.2 Technical data according to EPC and ISO

Technical specifications	
Frequency accuracy	max.± 10 ppm
Channel spacing	EU, EFTA, Turkey: 200 kHz US: 500 kHz China: 250 kHz
Modulation methods	ASK: DSB modulation & PR-ASK modulation Encoding, Manchester or Pulse Interval (PIE)
Effective radiant power	<ul style="list-style-type: none"> • ETSI/CMIIT: • FCC: <ul style="list-style-type: none"> • << 1.2 W ERP • < 2 W EIRP
Transmit power	≤ 0.5 W ERP

Reading range	
Antennas mounted on opposing sides (portal configuration)	3.5 m max. (recommended maximum value for configuration)
Antennas mounted on the same side	Max. 2 m (recommended maximum value for configuration; depending on the transponder)

ETSI frequencies	
Frequency range for Europe, EFTA, Turkey, South Africa ETSI EN 302 208 V1.3.1 (valid since August 10, 2010, publication in the Official Journal of the European Union)	865,7 ... 867.5 MHz (4 channels LBT optional at max. 2 W ERP)
Frequency range India	865 ... 860 MHz (10 channels at max. 4 W EIRP)
Frequency range Russia	866 ... 867 MHz (8 channels at 2 W ERP)
Frequency range Singapore	866 ... 869 MHz (11 channels at 0.5 W ERP)

FCC frequencies	
Frequency range USA; Argentina, Bolivia, Canada, Mexico	902 ... 928 MHz (50 channels at max. 4 W EIRP, frequency hopping)
Frequency range Brazil	515,25 ... 527.75 MHz (26 channels at max. 4 W EIRP, frequency hopping)
Frequency range South Korea	917,3 ... 920.3 MHz (7-16 channels at max. 4 W EIRP, frequency hopping)
Frequency range Thailand	920.25 ... 924.75 MHz (10 subchannels at max. 4 W ERP, frequency hopping)

Frequencies CMIIT	
Frequency range China	920,625 ... 924.375 MHz (16 subchannels at 2 W ERP)

5.2.5.3 Maximum number of readable tags

The maximum number of readable tags depends on the following parameters:

- Size of the antenna field
- Readability of the tags

For a transmit power of 500 mW ERP, the following is read when the tag RF620T is used:

- Max. 40 tags in the antenna field (tags perpendicular to antenna at 1 m distance). If 2 antennas are used, up to 80 tags can be recognized.
- Max. 18 tags per second

Note

Operation with 2 antennas

If you have configured 2 antennas as a gate, both antennas must be turned on at the same time. The reader multiplexes both antennas internally. The multiplexing time is typically 100 ms (internal read time per antenna).

5.2.6 Dimension drawings

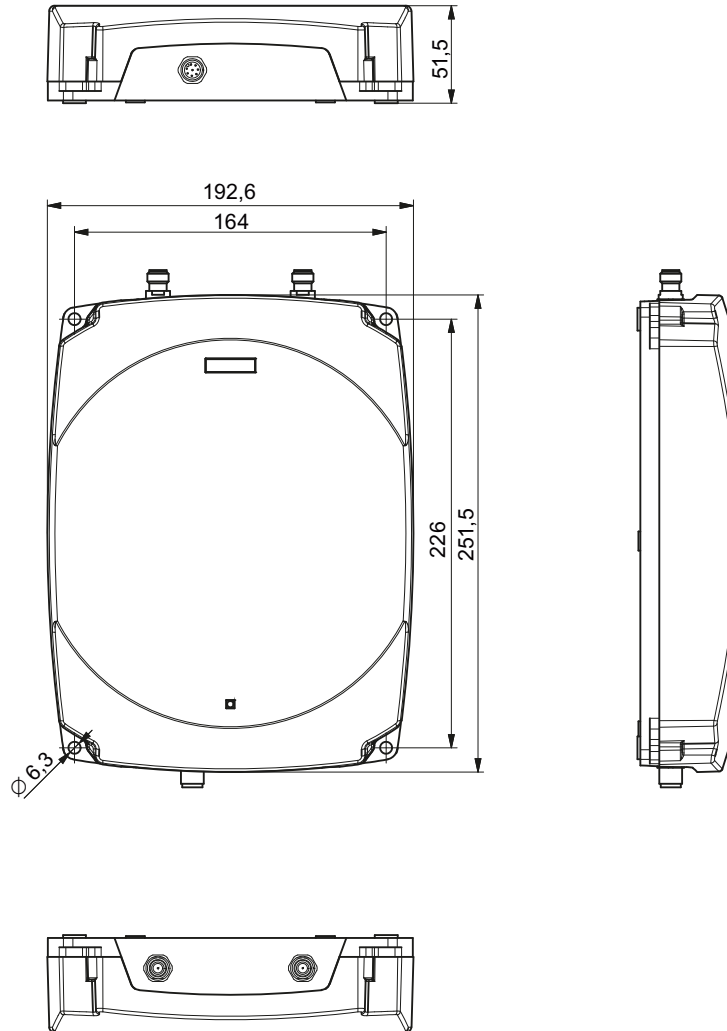

Figure 5-8 Dimension drawing for RF630R

All dimensions in mm (± 0.5 mm tolerance)

5.2.7 Certificates and approvals

Note

Marking on the readers according to specific approval

The certificates and approvals listed here apply only if the corresponding mark is found on the readers.

Table 5- 8 6GT2811-4AA00-0AA0, 6GT2811-4AA00-1AA1

Certificate	Description
	Conformity with R&TTE directive

Table 5- 9 6GT2811-4AA00-1AA0, 6GT2811-4AA00-1AA1



Standard	
 Federal Communications Commission	FCC CFR 47, Part 15 sections 15.247 Radio Frequency Interference Statement This equipment has been tested and found to comply with the limits for a Class B digital device, pursuant to Part 15 of the FCC Rules. FCC ID: NXW-RF630R (for 6GT2811-4AA00-1AA0) FCC ID: NXW-RF600R (for 6GT2811-4AA00-1AA1)
Industry Canada Radio Standards Specifications	RSS-210 Issue 7, June 2007, Sections 2.2, A8 IC: 267X-RF630 (for 6GT2811-4AA00-1AA0) IC: 267X-RF600R, Model: RF630R-2 (for 6GT2811-4AA00-1AA1)
	This product is UL-certified for the USA and Canada. It meets the following safety standard(s): UL 60950-1 - Information Technology Equipment Safety - Part 1: General Requirements CSA C22.2 No. 60950 -1 - Safety of Information Technology Equipment UL Report E 205089

Table 5- 10 6GT2811-4AA00-2AA1

Standard	
CMIIT Certification	China radio approval Marking on the reader: CMIIT ID:

5.2.7.1 FCC information

Siemens SIMATIC RF630R (FCC): 6GT2811-4AA00-1AA0, 6GT2811-4AA00-1AA1

FCC ID: NXW-RF630R (for 6GT2811-4AA00-1AA0)

FCC ID: NXW-RF600R (for 6GT2811-4AA00-1AA1)

This device complies with part 15 of the FCC rules.

Operation is subject to the following two conditions:

- (1) This device may not cause harmful interference, and
- (2) This device must accept any interference received, including interference that may cause undesired operation.

Caution

Any changes or modifications not expressly approved by the party responsible for compliance could void the user's authority to operate the equipment.

Note

This equipment has been tested and found to comply with the limits for a Class B digital device, pursuant to part 15 of the FCC Rules. These limits are designed to provide reasonable protection against harmful interference when the equipment is operated in a commercial environment. This equipment generates, uses, and can radiate radio frequency energy and, if not installed and used in accordance with the instruction manual, may cause harmful interference to radio communications. Operation of this equipment in a residential area is likely to cause harmful interference in which case the user will be required to correct the interference at his own expense.

FCC Notice

To comply with FCC part 15 rules in the United States, the system must be professionally installed to ensure compliance with the Part 15 certification.

It is the responsibility of the operator and professional installer to ensure that only certified systems are deployed in the United States. The use of the system in any other combination (such as co-located antennas transmitting the same information) is expressly forbidden.

FCC Exposure Information

To comply with FCC RF exposure compliance requirements, the antennas used for this transmitter must be installed to provide a separation distance of at least 20 cm from all persons and must not be co-located or operating in conjunction with any other antenna or transmitter.

5.2.7.2 IC-FCB information

Siemens SIMATIC RF630R (FCC): 6GT2811-4AA00-1AA0, 6GT2811-4AA00-1AA1

IC: 267X-RF630 (for 6GT2811-4AA00-1AA0)

IC: 267X-RF600, Model: RF630R-2 (for 6GT2811-4AA00-1AA1)

Industry Canada Notice

To reduce potential radio interference to other users, the antenna type and its gain should be so chosen that the equivalent isotropically radiated power (e.i.r.p.) is not more than that permitted for successful communication.

Transmitter power and antenna information for antennas with a gain less than 6 dBi:

This device has been designed to operate with the SIMATIC RF620A antenna 902-928, the SIMATIC RF640A antenna 902-928 as well as the SIMATIC RF660A antenna 902-928 listed below, and having a maximum gain of 5,5 dBi. Arbitrary transmission power settings in combination with other antennas or antennas having a gain greater than 5,5 dBi are strictly prohibited for use with this device. The required antenna impedance is 50 Ohms.

Transmitter power and antenna information for antennas with a gain greater 6 dBi:

This device requires professional installation. Antennas with a gain greater 6 dBi may be used provided the system does not exceed the radiation power of 4000 mW E.I.R.P. This device has been designed to operate with the SIMATIC RF642A antenna 902-928 exceeding the maximum gain of 5,5 dBi under the restriction that the RF power at the input of the antenna must be set to meet the following relation: $RF \text{ power (dBm)} \leq 30 \text{ dBm} - (\text{antenna gain (dBi)} - 6 \text{ dBi})$ Other antennas or system configurations for antennas having a gain greater than 6 dBi are strictly prohibited for use with this device. The required antenna impedance is 50 Ohms.

5.3 RF640R reader

5.3.1 Description

5.3.1.1 Overview

The SIMATIC RF640R is an active stationary reader in the UHF frequency range with an integrated antenna. As an alternative, an external UHF RFID antenna can be connected via a TNC reverse connector.

The maximum HF power output is 1000°W on the reader output. A radiant power of up to 2000 mW ERP is achieved when the appropriate antennas and antenna cables are used. The interfaces (Ethernet, M12 power supply, M12 digital I/O interface) are located along the narrow lower edge. These interfaces can be used to connect the reader to the power supply and the PC for parameterization.

The degree of protection is IP65.

	Pos.	Description
	(1)	TNC reverse interface for connecting an antenna
	(2)	LED status indicator
	(3)	24 VDC power supply
	(4)	Ethernet interface (TCP/IP)
	(5)	Digital I/O interface

Highlights

- The tags are read in accordance with the requirements of the EPC Global Class 1 Gen 2 or ISO/IEC 18000-6C standards
- Supports low-cost SmartLabels as well as reusable, rugged data media
- High reading speed: many tags can be read simultaneously (mass recording), rapidly moving tags are reliably recorded.
- The RF640R (ETSI) "6GT2811-3BA00-0AA0" is suitable for the frequency band 865 to 868 MHz UHF (EU, EFTA, Turkey). The reader supports the current standard ETSI EN 302 208 V1.3.1 (4-channel plan).
- The RF640R (FCC) "6GT2811-3BA00-1AA0" is suitable for the frequency band 902 to 928 MHz.
- The RF640R (CMIIT) "6GT2811-3BA00-2AA0" is suitable for the frequency band 920.125 to 924.875 MHz.
- You can choose between an internal or external antenna
- IP65 degree of protection
- Can be used for a high temperature range
- Dense Reader Mode (DRM) for environments in which many readers are operated in close proximity to each other.
- System integration over Ethernet (TCP/IP)
- Digital I/Os: Industry-compatible with high output power levels
- Configurable switching of the digital outputs with reader-internal logic
- Data processing in the reader (filtering, smoothing, etc.)
- Additional information for each acquired RFID transponder (RSSI values, time stamp)

5.3.1.2 Ordering data

Ordering data RF640R

Product	Order number
RF640R (ETSI) reader for EU, EFTA, Turkey	6GT2811-3BA00-0AA0
RF640R (FCC) reader for the USA	6GT2811-3BA00-1AA0
RF640R (CHINA) reader for CMIIT	6GT2811-3BA00-2AA0

Ordering data for antennas and antenna cables

For readers with an external antenna connector (MLFB: 6GT2811-3BA00-xAA0), the following antennas and antenna cables are available:

Product	Order number
Antennas <ul style="list-style-type: none"> • RF620A antenna for EU, EFTA, Turkey (868 MHz) • RF620A antenna for FCC (915 MHz) • RF640A antenna (865 to 928 MHz) • RF642A antenna (865 to 928 MHz) • RF660A antenna for EU, EFTA, Turkey (868 MHz) • RF660A antennas for the USA and China (915°MHz) 	<ul style="list-style-type: none"> • 6GT2812-1EA00 • 6GT2812-1EA01 • 6GT2812-0GA08 • 6GT2812-1GA08 • 6GT2812-0AA00 • 6GT2812-0AA01
Antenna cable <ul style="list-style-type: none"> • 3 m (cable attenuation: 1.0 dB) • 5 m (cable attenuation: 1.25 dB, suitable for drag chains) • 10 m (cable attenuation: 4.0 dB) • 10 m (cable attenuation: 2.0 dB) • 15 m (cable attenuation: 4.0 dB, suitable for drag chains) • 20 m (cable attenuation: 4.0 dB) 	<ul style="list-style-type: none"> • 6GT2815-0BH30 • 6GT2815-2BH50 • 6GT2815-0BN10 • 6GT2815-1BN10 • 6GT2815-2BN15 • 6GT2815-0BN20

Ordering data (accessories)

Product	Order number
Antenna mounting kit	6GT2890-0AA00
Connecting cable and connectors <ul style="list-style-type: none"> • Digital I/O, open cable ends, 5 m • Ethernet: 10 m (cross cable) • Ethernet connector on reader according to IEC PAS 61076-3-117IE RJ45 Plug PRO (IP67) • Ethernet connector, Standard IE FastConnect RJ45 Plug 180 (IP20) • Ethernet cable sold by the meter, green 	<ul style="list-style-type: none"> • 6GT2891-0DH50 • 6GT2891-1HN10 • 6GK1901-1BB10-6AA0 • 6GK1901-1BB10-2AB0 • 6XV1840-2AH10
Wide-range power supply unit for SIMATIC RF systems <ul style="list-style-type: none"> • With EU plug • With UK plug • With US plug 	<ul style="list-style-type: none"> • 6GT2898-0AA00 • 6GT2898-0AA10 • 6GT2898-0AA20

Product	Order number
24 V connecting cable 5 m between reader and power supply (for RF640R only, pin assignment is PNO compatible)	6GT2891-0NH50
Set of protective caps Contains 3 protective caps for antenna output and one protective cap for digital I/O interface (required for IP65 degree of protection when some connectors are unused)	6GT2898-4AA00
RFID DVD "Software & Documentation"	6GT2080-2AA20

See also

Support homepage (<http://www.siemens.com/automation/service&support>)

5.3.1.3 Status display

The device is equipped with a three colored LED. The LED can be lit in green, red or orange. The meaning of the indication changes in accordance with the color and state (on, off, flashing) of the LED:

Green LED	Red LED	Orange LED	Meaning
Off	Off	Off	The device is not connected to a power supply.
Flashing	Off	Off	In normal operation, no communication with the reader has taken place for a longer period of time.
On	Off	Off	The device is ready. The connection is established.
Off	Off	Flashing	More than one tag is in the field.
Off	Off	On	The device is starting up. The connection is established. Exactly one tag is in the field during normal operation.
Off	Flashing	Off	Error states with flash codes (see section Flashing codes of the RF600 readers with Ethernet interface (Page 385))
Off	flashes 2x	Off	At the end of the startup

Note

LED is not lit orange?

If the LED does not light up orange even though a tag is located within the field, common causes are:

- Antenna is switched off
- A tag is used, that is not compatible with the reader protocol (EPC Global Class 1 Gen 2).
- Tag is defective
- Reader or antenna has a defect
- Tag is not in the field of radiation of the transmit antenna

For more detailed information on the flash codes of the reader see section Flashing codes of the RF600 readers with Ethernet interface (Page 385)

5.3.1.4 Pin assignment of the digital I/O interface

Pin assignment, socket

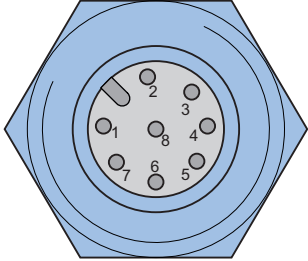
Digital I/O socket (on reader side)	Pin	Pin assignment
	1	GND (output to supply the digital outputs [not electrically isolated])
	2	VCC (output for supplying the digital outputs [not RF310M, RF680M electrically isolated])
	3	DO common
	4	DO 0
	5	DO 1
	6	DI 0
	7	DI common
	8	DI 1
	Shield	is applied to the reader housing so that the knurled ring is connected to GND of the reader.

View of the connector

Table 5- 11 Digital I/O, for cable with open cable ends

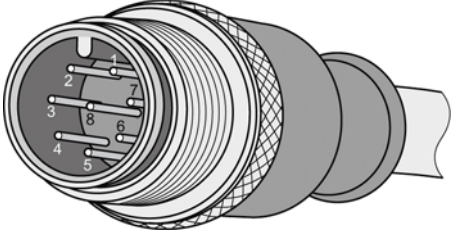
View of M12 connector	M12 pin	Wire color	Pin assignment
	1	white	GND (output to supply the digital outputs [not electrically isolated])
	2	brown	VCC (output for supplying the digital outputs [not electrically isolated])
	3	green	DO common
	4	yellow	DO 0
	5	gray	DO 1
	6	pink	DI 0
	7	blue	DI common
	8	red	DI 1
	Knurled ring	Shield	Knurled ring connected to GND of the reader

Wiring diagram M8 plug (cable end)

You will need to assemble your reader cable with a suitable connector that fits the interface shown above. Keep to the following wiring diagram:

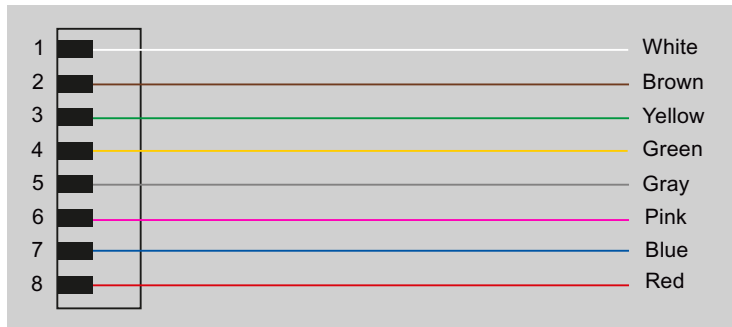

Figure 5-9 Wiring diagram M8 connector

5.3.1.5 Connection scheme for the digital I/O interface

Connection possibilities

You can connect the RF640R reader in different ways. In general, the outputs and inputs should be connected as follows:

Output Output (0), (1)

- Each output is rated for 0.5 A current and is electronically protected.
- Two digital outputs can be operated simultaneously each with up to 0.5 A (up to 1.0 A in total).
- The outputs are optically isolated through optocouplers.

Input Inport (0), (1)

- The inputs are optically isolated through optocouplers.
- Level Low 0 ... 3 V; High 3.6 to 24 V
- Sampling rate < 20 ms

The following diagrams illustrate various connection possibilities.

Voltage infeed through internal source (no electrical isolation)

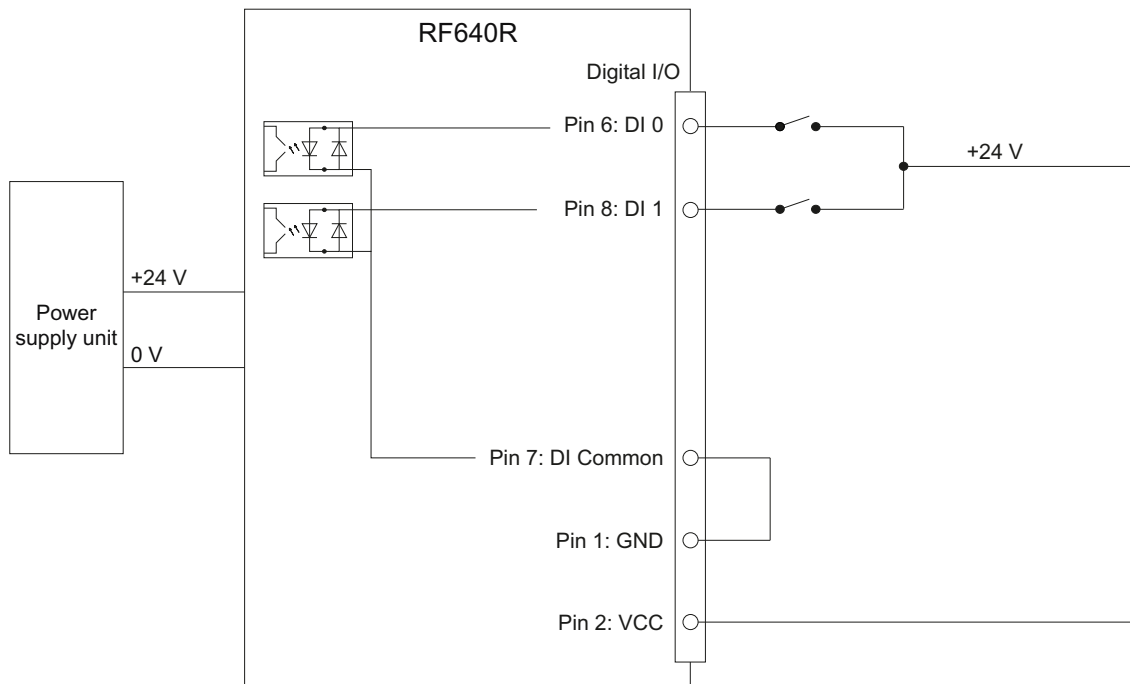

Figure 5-10 Example circuit 1: Digital inputs

Alternative connection possibilities:

- Pin 2 (VCC) to Pin 9 DI Common
- Pin 1 GND to busbar inputs

Voltage infeed through external source

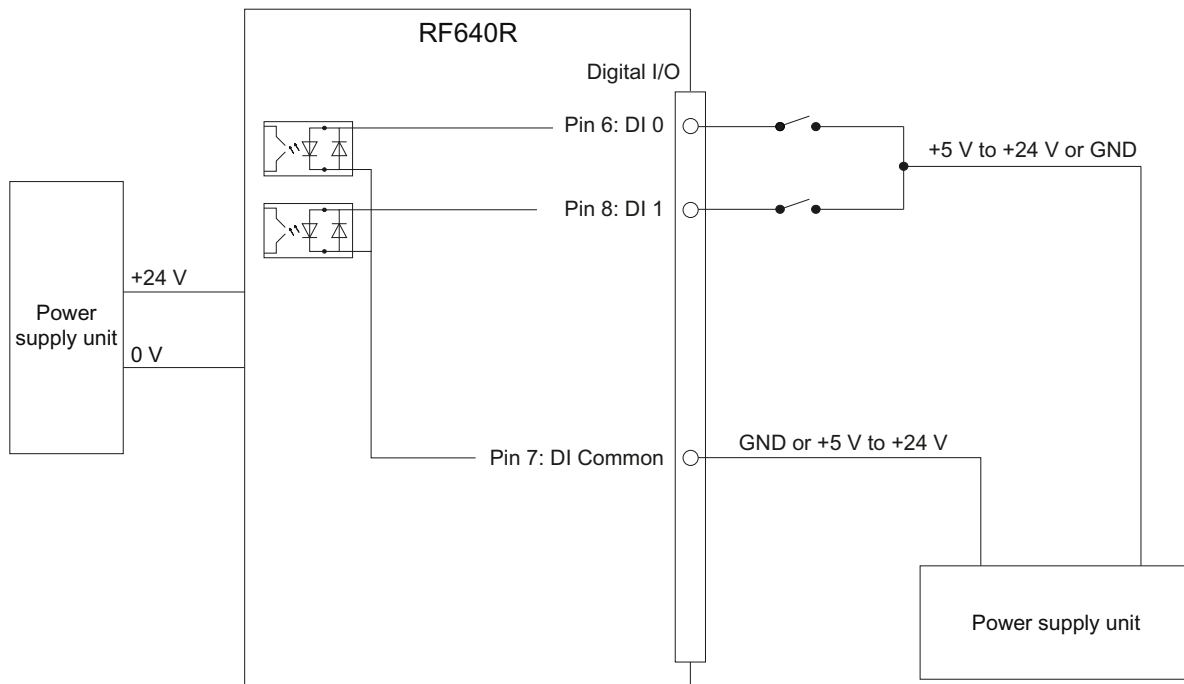

Figure 5-11 Example circuit 2: Digital inputs

Voltage infeed through external source with various voltages

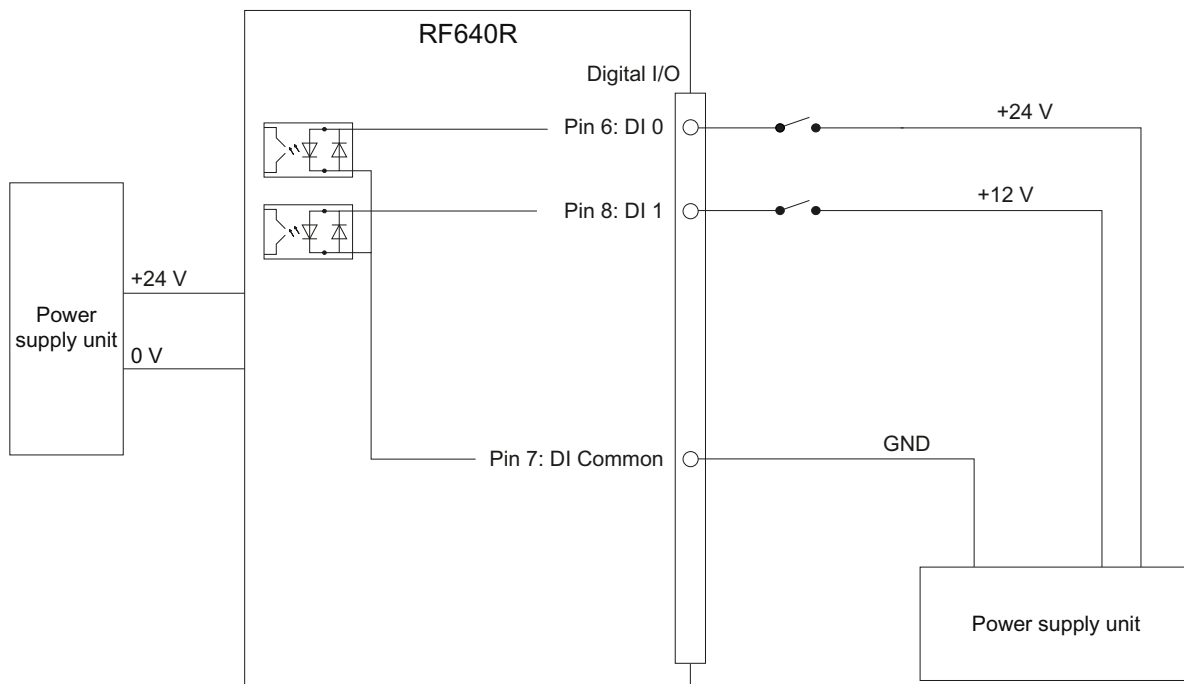

Figure 5-12 Example circuit 3: Digital inputs

Voltage infeed through internal source

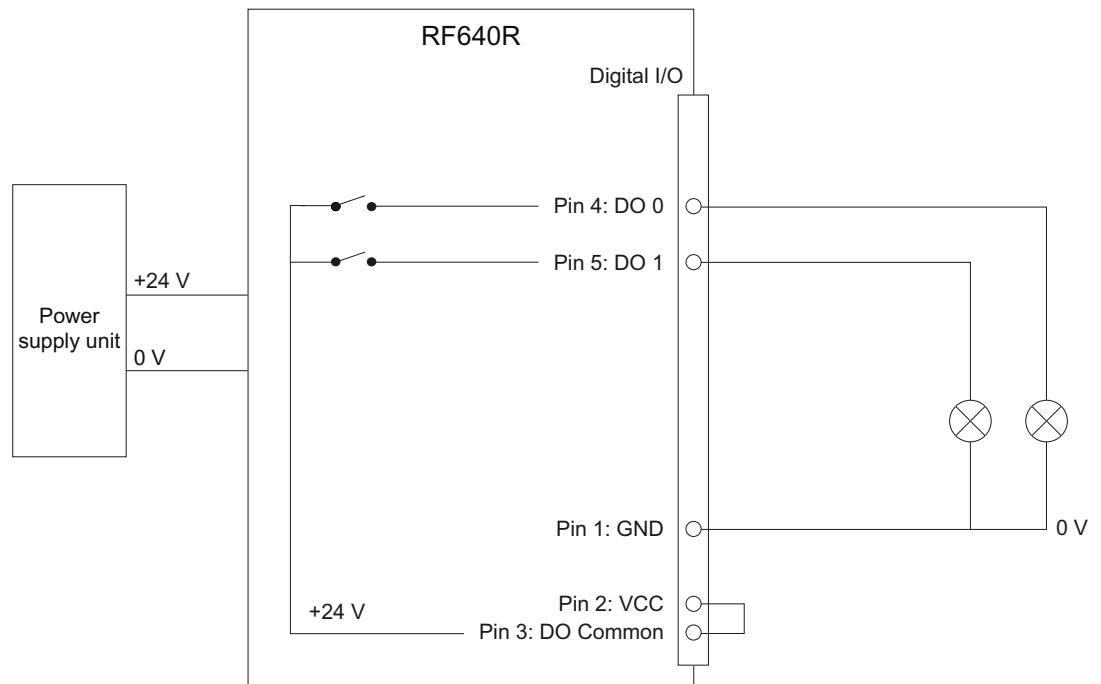

Figure 5-13 Example circuit 4: Digital outputs

Alternative connection possibilities:

- Pin 1 GND to Pin 3 DO Common
- Pin 2 (VCC) to busbar outputs

Voltage infeed through external source

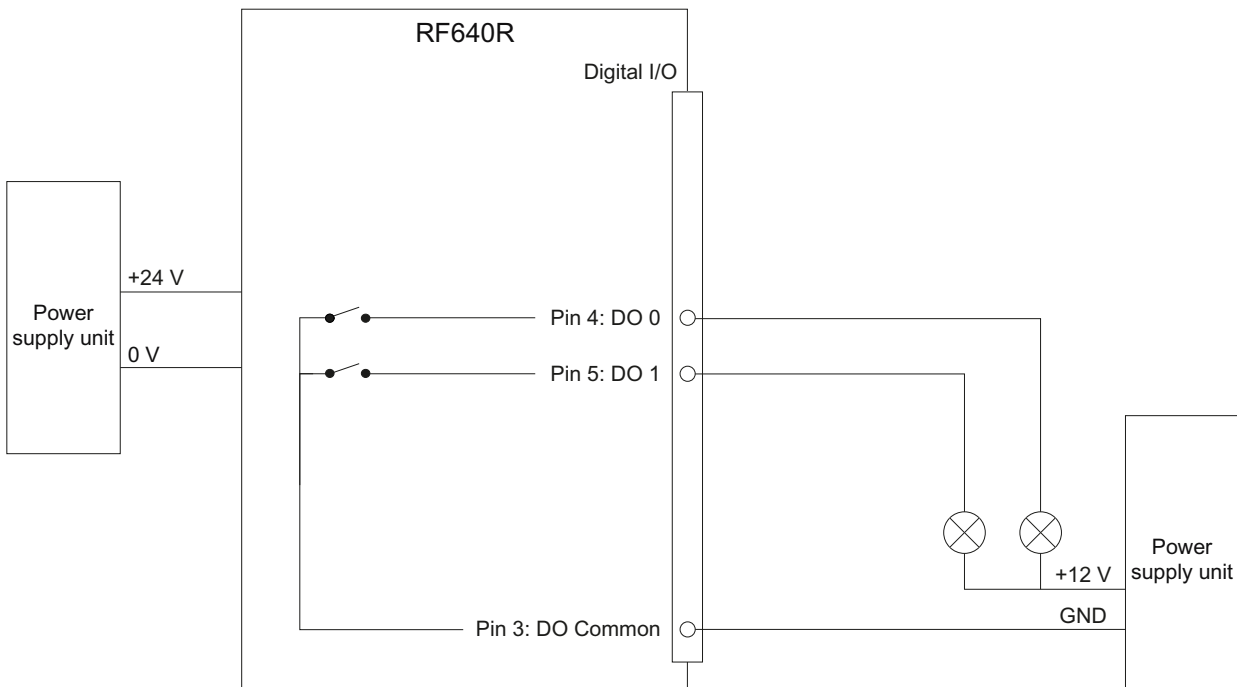

Figure 5-14 Example circuit 5: Digital outputs

Voltage infeed through an external source is shown here for 12°V by way of example. Other voltages are also permissible.

Voltage infeed through external source with various voltages

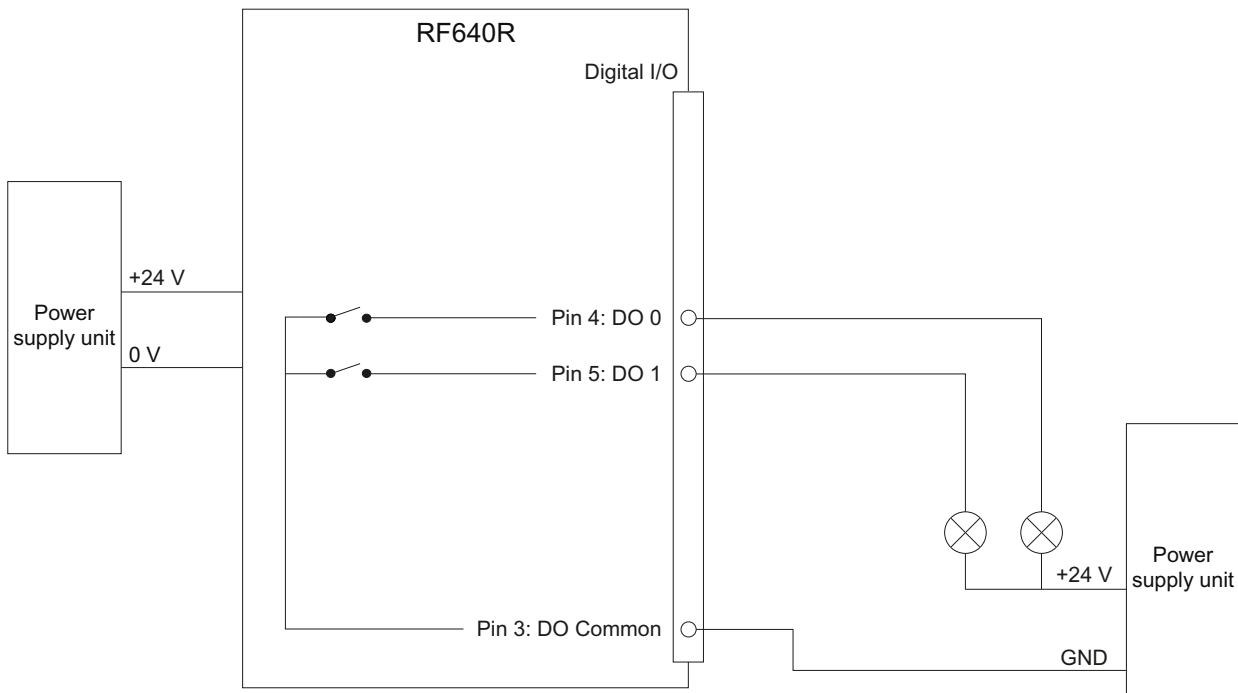

Figure 5-15 Example circuit 6: Digital outputs

5.3.1.6 Pin assignment for power supply

Pin assignment of the power connections

Power connector (on reader side)	Pin	Pin assignment
	1	24 VDC
	2	Not connected
	3	Ground (0 V)
	4	Not connected

The power connector of the RF640R is conforms with the PNO standard, in other words, normal PROFINET IO connectors fit this interface.

5.3.1.7 Pin assignment for Industrial Ethernet interface

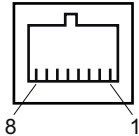
Industrial Ethernet (on reader side)	Pin	Pin assignment
	1	Transmit Data (+)
	2	Transmit Data (-)
	3	Receive Data (+)
	4	Terminated
	5	Terminated
	6	Receive Data (-)
	7	Terminated
	8	Terminated

NOTICE

We recommend that only original Siemens Ethernet crossover cables are used (10 m cable: Order No. 6GT2891-1HN10) or the Siemens connector (see Section Ordering data (Page 134)) for connecting to the Ethernet socket of the reader. If plug-in connectors from other manufacturers are used, it may be difficult or even impossible to remove the plug from the reader

Note

No autocrossover

The RF640R reader does not support autocrossover!

5.3.1.8 Grounding connection

The RF640R can be electrically connected to ground potential by a contact washer. The tightening torque must be increased in this case to ensure that electrical contact is made (2.7 Nm).

⚠ WARNING

Hazardous voltage due to lightning strikes

Death or serious injury may occur as a result of lightning strikes to antennas mounted outside buildings.

If the reader is operated with antennas mounted outside buildings, it is imperative that the reader is electrically connected to the ground potential.

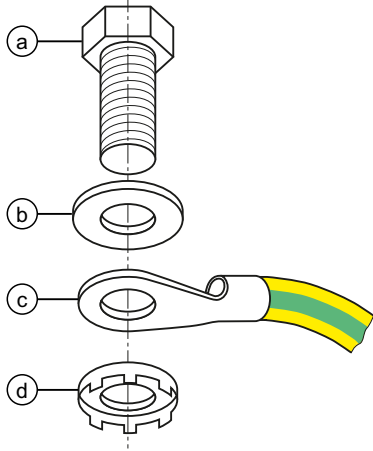
Ground connection	
	(a) Hexagon-head screw
	(b) Plain washer
	(c) Cable lug
	(d) Contact washer: Use contact washers according to the Siemens standard SN 70093-6-FSt-fINnc-480h for ground connection, Siemens item No.: H70093-A60-Z3

5.3.2 Planning the use

5.3.2.1 Selecting the antenna

With the SIMATIC RF640R, there are two ways of using the antenna that are mutually exclusive:

- Either you use the internal antenna of the reader
- Or you connect an external antenna to the interface of the reader. The internal antenna of the reader can then, however, not be used at the same time.

You can select the active antenna using the parameter assignment software "RF-MANAGER Basic V2" or using an XML command.

5.3.2.2 Internal antenna

Minimum mounting clearances of two readers

The RF640R has a circular polarized antenna. At 2000 mW ERP radiated power, due to the aperture angle of the antennas, their fields can overlap considerably. It is no longer possible to clarify in which antenna field access to the data of a tag is performed.

In order to avoid this, always keep a minimum distance of 6 m between two readers with the maximum radiated power of 500 mW ERP.

Dense Reader Mode (DRM)

The readers can also interfere with each other (secondary fields), if the channels (Reader TX, Transponder TX) overlap. In order to prevent a transponder channel overlapping with a reader channel, we recommend that the Dense Reader Mode (DRM) is used.

Note

Protective cap

If you use the internal antenna of the reader, we recommend that you close the external, unused antenna connector on the reader using the supplied protective cap.

Antenna diagram for RF640R (ETSI)

The following radiation diagrams show the directional characteristics of the internal antenna of the RF640R (ETSI) reader. For the spatial presentation of the directional characteristics, the vertical plane (Azimuth section) as well as the horizontal plane (elevation pattern) must be considered. This results in a spatial image of the directional radiation pattern of the antenna with its main and auxiliary fields.

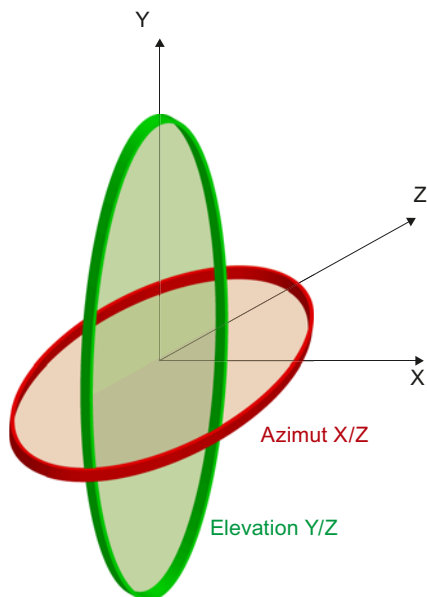

Radiation diagram (Azimuth section)

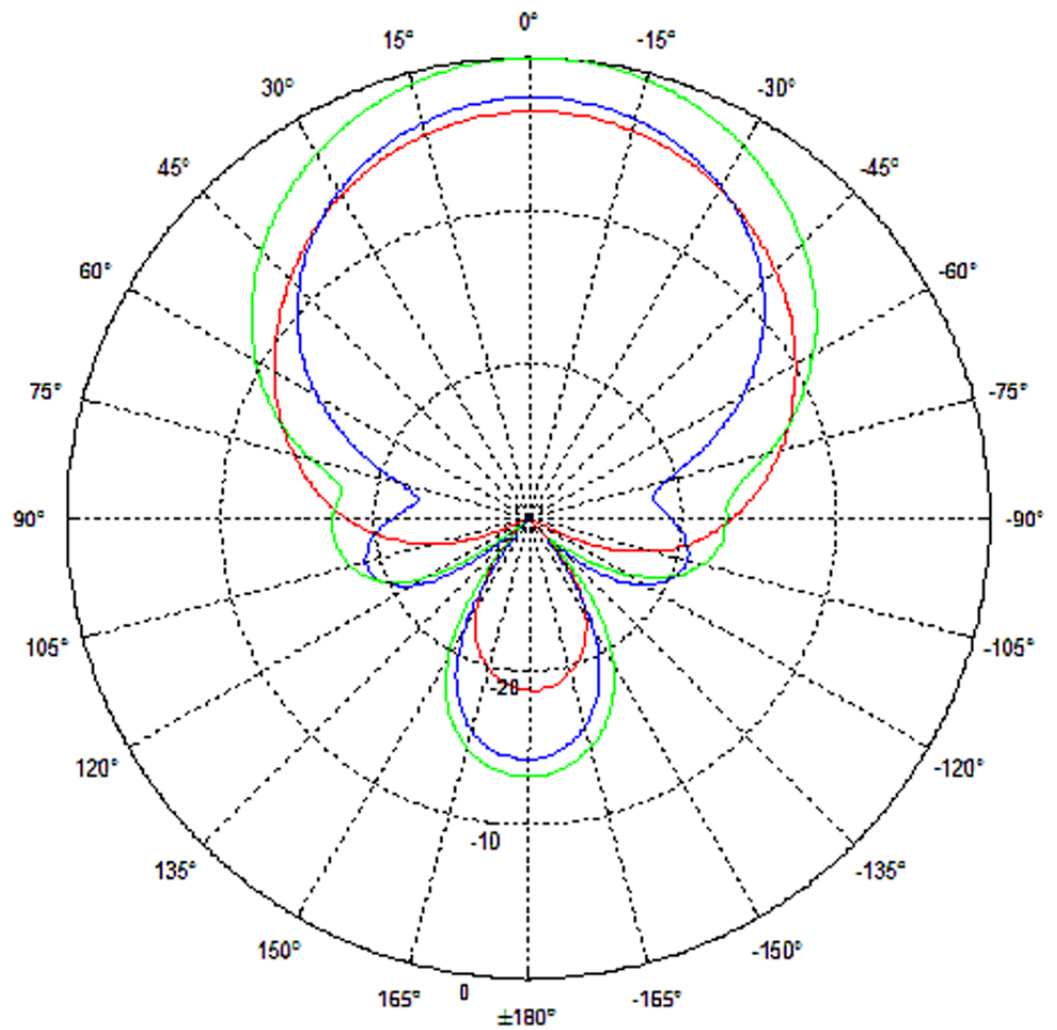

- Vertical component of the polarization direction of the antenna
- Horizontal component of the polarization direction of the antenna
- Right circular component of the polarization direction of the antenna

Figure 5-16 Azimuth section

Radiation diagram (elevation section)

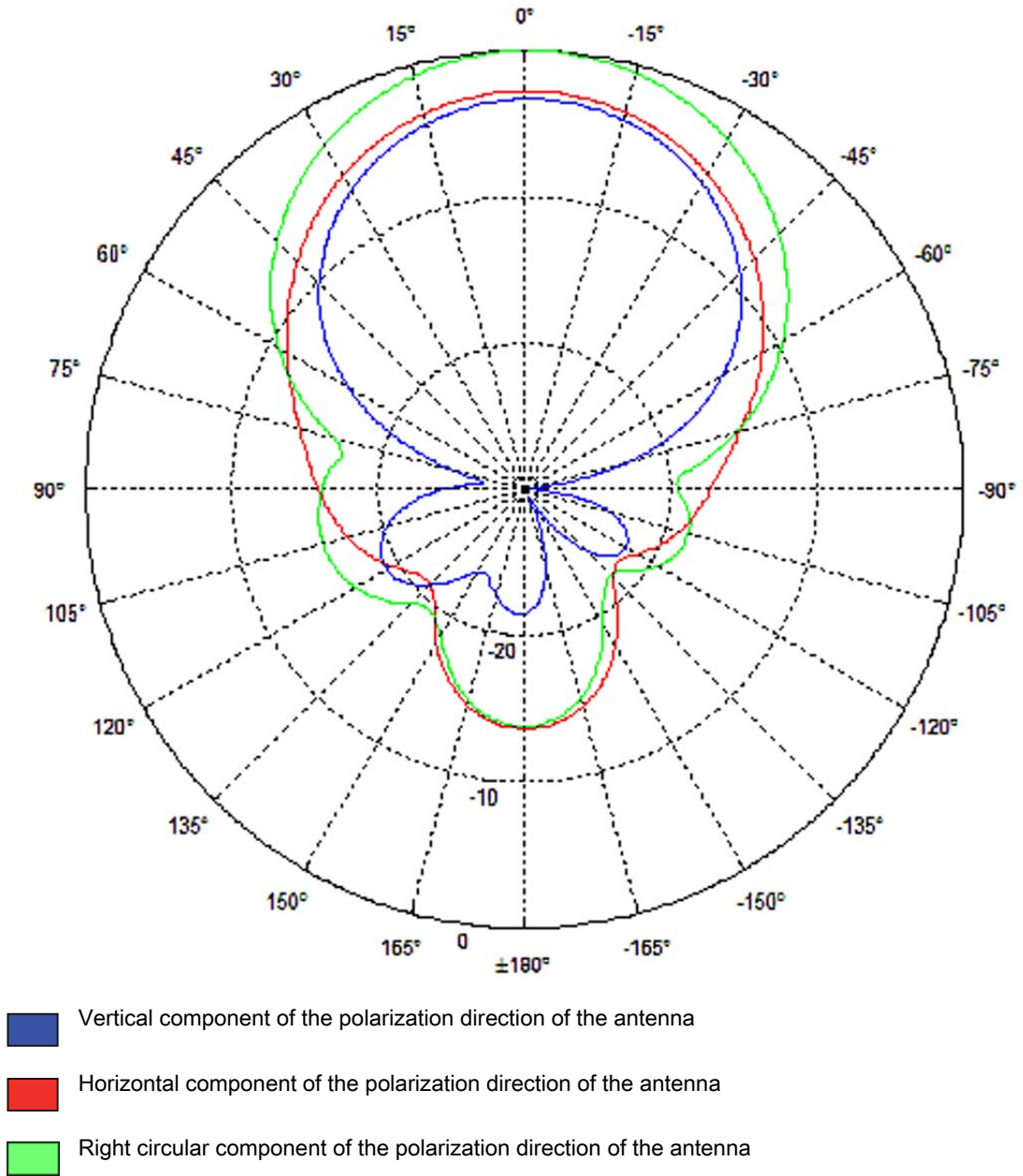

Figure 5-17 Elevation section

Overview of the antenna parameters

Table 5- 12 Maximum linear electrical aperture angle at 865 MHz:

Azimuth section	77,7°
Elevation section	66,1°
Typical antenna gain in the frequency range 865 to 868 MHz	4.0 dBi
Antenna axis ratio	0.7 dB

See also section Guidelines for selecting RFID UHF antennas (Page 54)

Antenna diagram for RF640R (FCC)

The following radiation diagrams show the directional characteristics of the internal antenna of the RF640R (FCC) reader. For the spatial presentation of the directional characteristics, the vertical plane (Azimuth section) as well as the horizontal plane (elevation section) must be considered. This results in a spatial image of the directional radiation pattern of the antenna with its main and auxiliary fields.

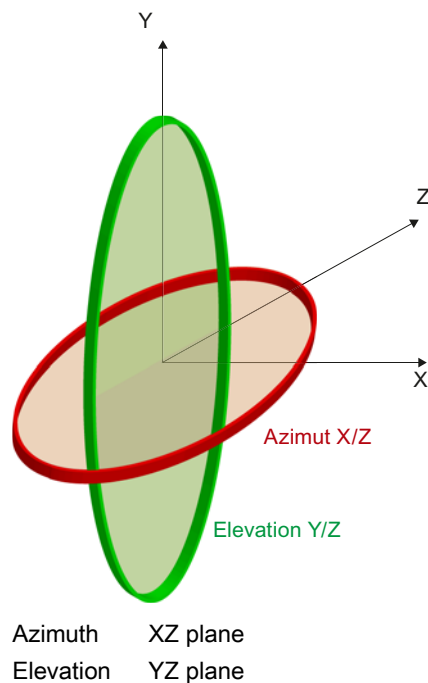

Radiation diagram (Azimuth section)

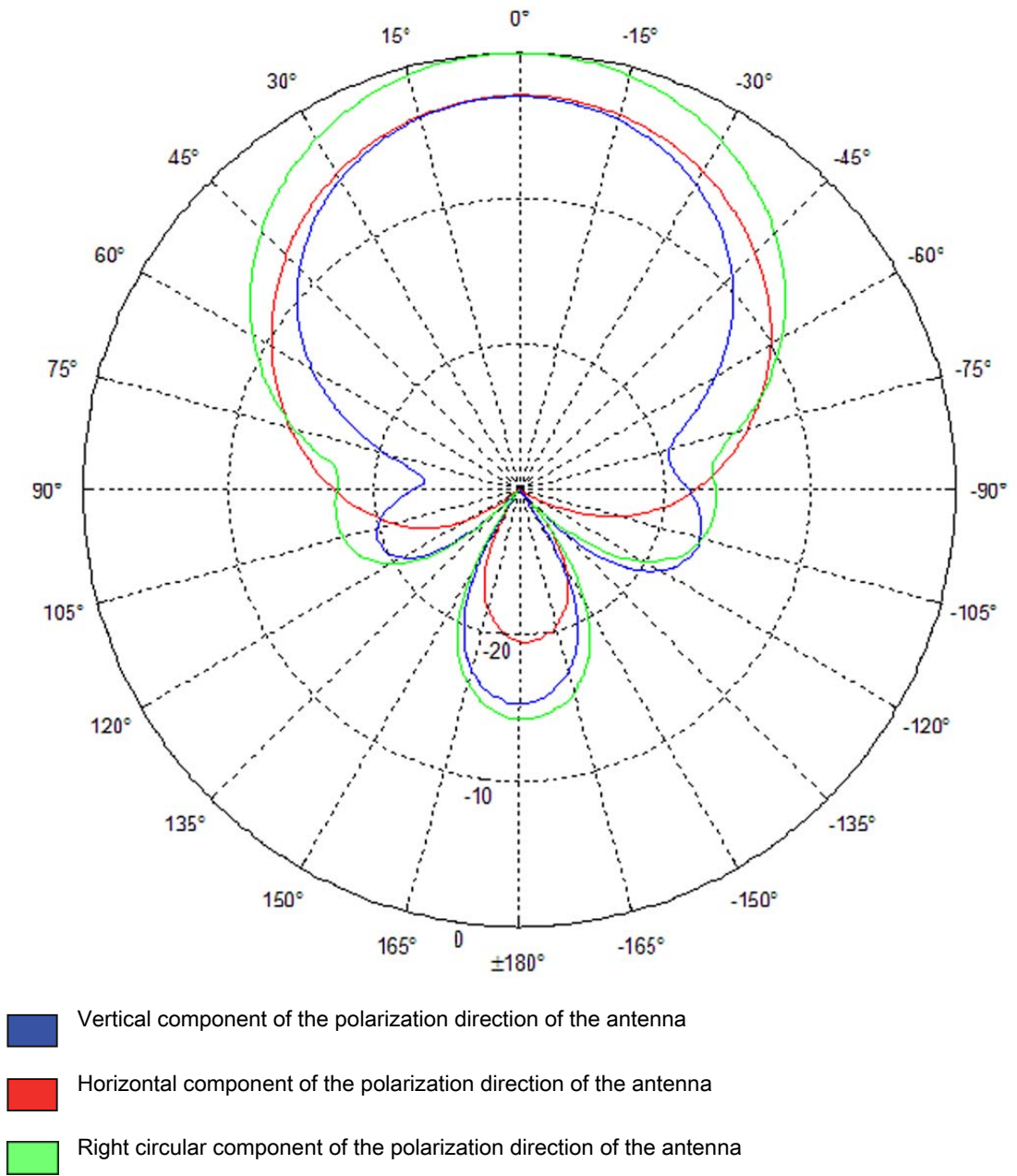
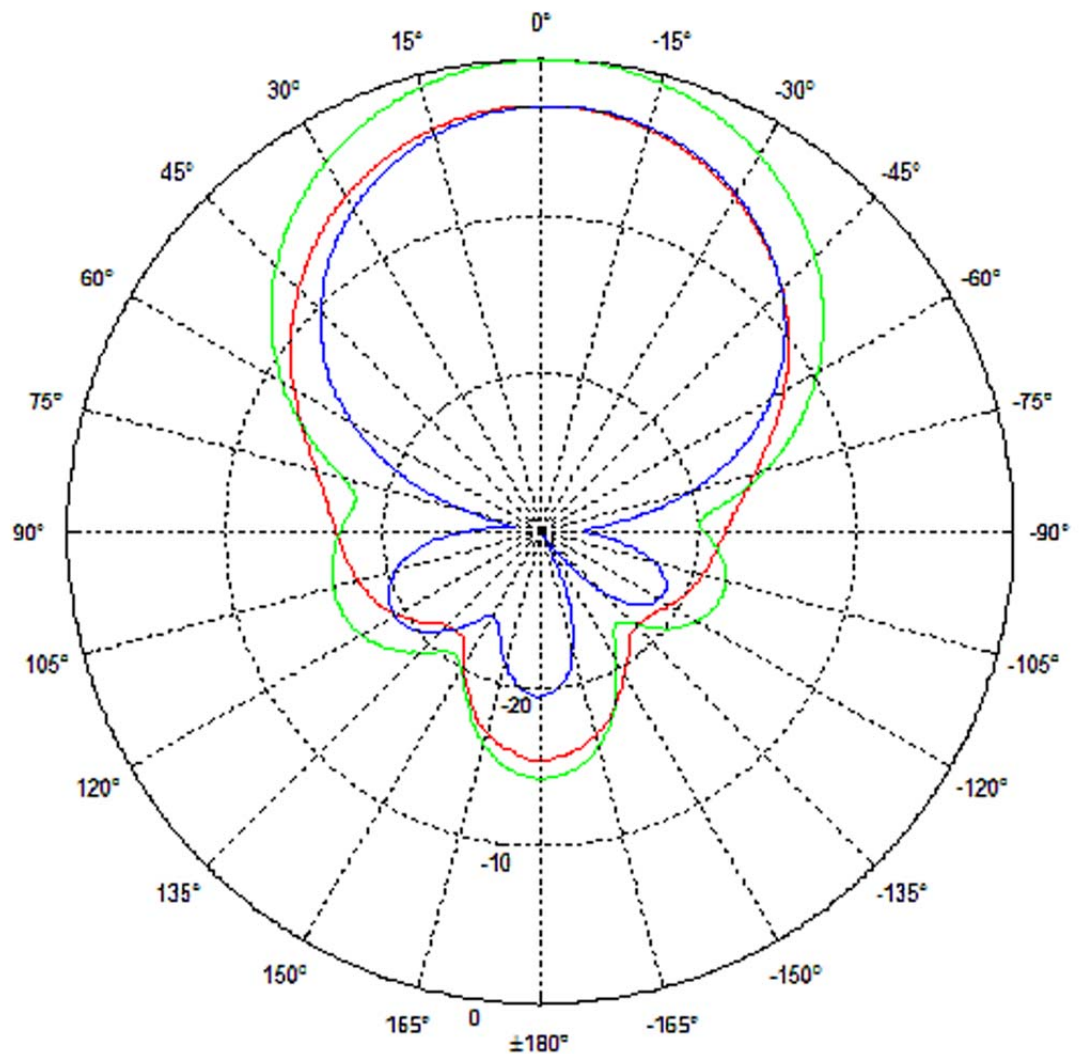

Figure 5-18 Azimuth section

Radiation diagram (elevation section)





-  Vertical component of the polarization direction of the antenna
-  Horizontal component of the polarization direction of the antenna
-  Right circular component of the polarization direction of the antenna

Figure 5-19 Elevation section

Overview of the antenna parameters

Table 5- 13 Maximum linear electrical aperture angle at 865 MHz:

Azimuth section	75,4 °
Elevation section	69,1 °
Typical antenna gain in the frequency range 902 to 928 MHz	4.0 dBi ± 0.5 dB
Antenna axis ratio	<1 dB

see also section Guidelines for selecting RFID UHF antennas (Page 54).

Interpretation of directional radiation patterns

The following overview table will help you with the interpretation of directional radiation patterns.

The table shows which dBi values correspond to which read/write ranges (in %): You can read the radiated power depending on the reference angle from the directional radiation patterns, and thus obtain information on the read/write range with this reference angle with regard to a transponder.

The dBr values correspond to the difference between the maximum dBi value and a second dBi value.

Deviation from maximum antenna gain [dBr]	Read/write range [%]
0	100
-3	70
-6	50
-9	35
-12	25
-15	18
-18	13

Example

As one can see from the section Antenna diagram for RF640R (ETSI) (Page 146), the maximum antenna gain is 0 dB. In the Azimuth diagram, the antenna gain falls by 3°dB at approximately ± 39°. Therefore the dBr value is -3. The antenna range is only 50% of the maximum range at ± 39° from the Z axis within the horizontal plane.

Antenna/read point configurations

The RF640R reader has an internal circular polarized antenna. You can cover one read point with this antenna. When several RF640R readers are used, the readers are addressed via the SIMATIC level.

5.3.2.3 External antenna

Preassembled standard cables in lengths of 3 m, 5 m, 15 m and 20 m are available to connect the antenna.

The read range is limited by the cable loss. The maximum range can be achieved with the cable 6GT2815-0BH30 (length 3 m), since this has the lowest cable loss.

Examples of possible antenna reading point configurations

- A data source with an external antenna for a reading point.
- As an alternative, a data source with an internal antenna for a reading point.

5.3.3 Installing / mounting

Requirement

WARNING

Make sure that the wall or ceiling can hold four times the total weight of the device.

Note

Close unused connectors

If you do not use connectors on the reader, it is advisable to close the unused connectors with protective caps. You can order the protective cap set using the MLFB specified in the section "Ordering data".

CAUTION

Emitted radiation

The transmitter complies with the requirements of Health Canada and the FCC limit values for subjecting persons to HF radiation, provided that a minimum spacing of 26 cm exists between antenna and person. When the antennas are installed, you must therefore ensure that a minimum spacing of 26 cm is maintained between personnel and antennas.

Mounting/installing the device

You can mount the reader in two different ways:

- Via a standardized VESA 100 mounting system using the Antenna Mounting Kit (see section Mounting with antenna mounting kit (Page 262)). Tighten the M4 screws on the rear of the reader using a maximum torque of ≤ 1.3 Nm.
- Directly onto a flat surface.

The positions of the fixing holes for the device are shown in the section Dimension drawings (Page 158).

5.3.4 Configuration/integration

An Ethernet interface is available for integrating the device into system environments/networks. Over the Ethernet interface and with a direct connection to the PC, the RF640R can be configured in two different ways:

- Using RF-MANAGER Basic V2
- Using a user application (XML commands)

The communication interface transfers the data over the RF-MANAGER Basic to the IT, ERP and SCM systems as well as to SIMATIC controllers. Alternatively the data is transferred to user applications by means of XML commands.

Simple process controls (e.g. signal lights) can be directly implemented using the write/read device via two digital inputs and outputs.

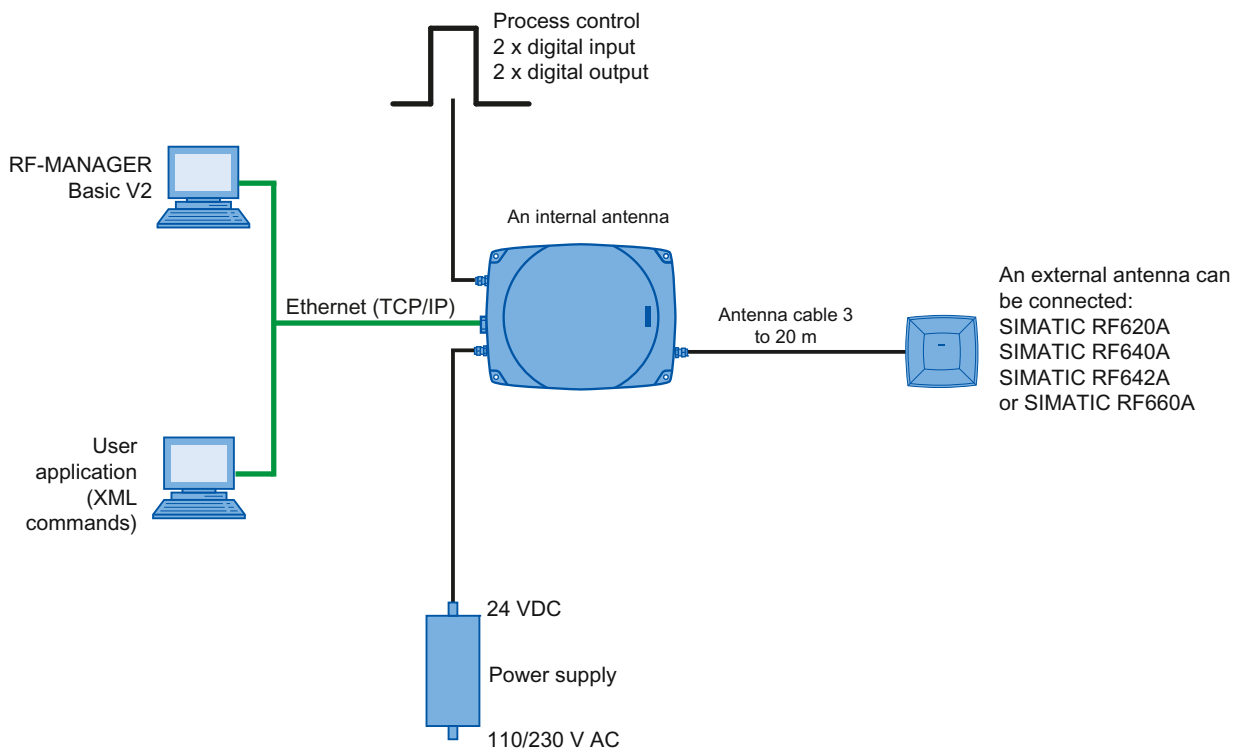

Figure 5-20 Overview of configuration of the RF640R reader

5.3.5 Technical data

5.3.5.1 Mechanical data

Mechanical data	
Weight	approx. 1700 g
Housing dimensions (L x W x H)	252 x 193 x 52 mm, without connections
Material for housing top section	ABS (GF 20), silicone-free
Material for housing bottom section	Aluminum
Color of housing top section	Pastel turquoise
Color of housing bottom section	Silver
Status displays on the device	1 LED Colors: red, yellow, green
Interfaces	
Antenna connectors	1 x RTNC plug
Power supply	1 x plug (4-pin M12)
Digital I/O interface	1 x socket (8-pin M12)
Digital inputs	2
Digital outputs	2 (500 mA each; max. 1000 mA in total)
Ethernet	RJ-45 TCP/IP (push-pull) 10/100 Mbps
MTBF in years	14.3

Thermal and electrical properties			
Power supply		20 to 30 VDC ¹	
<ul style="list-style-type: none"> Permitted range 			
Power supply		Current consumption (in standby mode, no transmit power)	Power requirement (in standby mode, no transmit power)
	20 V input voltage on the reader, typical	140 mA	2.8 W
	24 V input voltage on the reader, typical	120 mA	2.88 W
	30 V input voltage on the reader, typical	100 mA	3.0 W
Power supply		Current consumption (at 1000 mW transmit power / 1600 mW ERP radiated power)	Power requirement (at 1000 mW transmit power / 1600 mW ERP radiated power)
	20 V input voltage on the reader, typical	530 mA	10.6 W
	24 V input voltage on the reader, typical	450 mA	10.8 W
	30 V input voltage on the reader, typical	370 mA	11.1 W
Rampup time		19 s	

¹⁾ All supply and signal voltages must be safety extra low voltage (SELV/PELV according to EN 60950)

24 VDC supply: safe (electrical) isolation of extra-low voltage (SELV / PELV acc. to EN 60950)

Mechanical environmental conditions	
Shock resistant acc. to EN 60068-2-27	50 g ¹
Vibration acc. to EN 60068-2-6	20 g ¹
Climatic conditions	
Ambient temperature during operation	-25 °C to +55 °C (a 10-minute warm-up time must be allowed at an operating temperature below -20 °C)
Ambient temperature for transport and storage	-40 °C to +85 °C

1) The values for shock and vibration are maximum values and must not be applied continuously.

EMC & approvals/conformity for ETSI variant	
Electromagnetic compatibility	ETSI EN 301 489-1 / -3 EN 302 208 V1.3.1 EN 302 208 V1.4.1
Approvals/Conformity	<ul style="list-style-type: none"> • Radio according to the R&TTE directive • CE • ETSI EN 302 208 V1.3.1 • ETSI EN 302 208 V1.4.1 • Reader degree of protection acc. to EN 60529 (IP65) • RoHS-compliant according to EU Directive 2002/95/EC • Human exposure

EMC & approvals for FCC variant	
Electromagnetic compatibility	FCC Part 15
Approvals	<ul style="list-style-type: none"> • FCC, cULus • IEC60950, including US and Canadian variants of it • Reader degree of protection acc. to EN 60529 (IP65) • FCC CFR47 Part 15.247 • RoHS-compliant according to EU Directive 2002/95/EC • Industrial Canada, RSS-210, Issue 7, June 2007

5.3.5.2 Technical data according to EPC and ISO

Technical specifications	
Frequency accuracy	max.± 10 ppm
Channel spacing	EU, EFTA, Turkey: 200 kHz US: 500 kHz China: 250 kHz
Modulation methods	ASK: DSB modulation & PR-ASK modulation Encoding, Manchester or Pulse Interval (PIE)
Effective radiated power with internal antenna <ul style="list-style-type: none"> ETSI/CMIIT: FCC 	<ul style="list-style-type: none"> ≤ 1.6 W ERP ≤ 3.3 W EIRP
Effective radiated power with external antenna <ul style="list-style-type: none"> ETSI/CMIIT: FCC 	<ul style="list-style-type: none"> ≤ 2.0 W ERP ≤ 4.0 W EIRP
Transmit power <ul style="list-style-type: none"> ETSI/CMIIT: FCC 	<ul style="list-style-type: none"> ≤ 1.0 W ≤ 1.25 W

Reading range	
Antennas mounted on opposing sides (portal configuration)	max. 10 m
Antennas mounted on the same side	max. 5 m (dependent on transponder)

ETSI frequencies	
Frequency range for Europe, EFTA, Turkey, South Africa ETSI EN 302 208 V1.3.1 (valid since August 10, 2010, publication in the Official Journal of the European Union)	865,7 ... 867.5 MHz (4 channels LBT optional at max. 2 W ERP)
Frequency range India	865 ... 860 MHz (10 channels at 4 W EIRP)
Frequency range Russia	866 ... 867 MHz (8 channels at 2 W ERP)
Frequency range Singapore	866 ... 869 MHz (11 channels at 0.5 W ERP)

FCC frequencies	
Frequency range USA; Argentina, Bolivia, Canada, Mexico	902 ... 928 MHz (50 channels at max. 4 W EIRP, frequency hopping)
Frequency range Brazil	515,25 ... 527.75 MHz (26 channels at max. 4 W EIRP, frequency hopping)
Frequency range South Korea	917,3 ... 920.3 MHz (7-16 channels at max. 4 W EIRP, frequency hopping)
Frequency range Thailand	920.25 ... 924.75 MHz (10 subchannels at max. 4 W ERP, frequency hopping)

Frequencies CMIT	
Frequency range China	920,625 ... 924.375 MHz (16 subchannels at 2 W ERP)

5.3.6 Dimension drawings

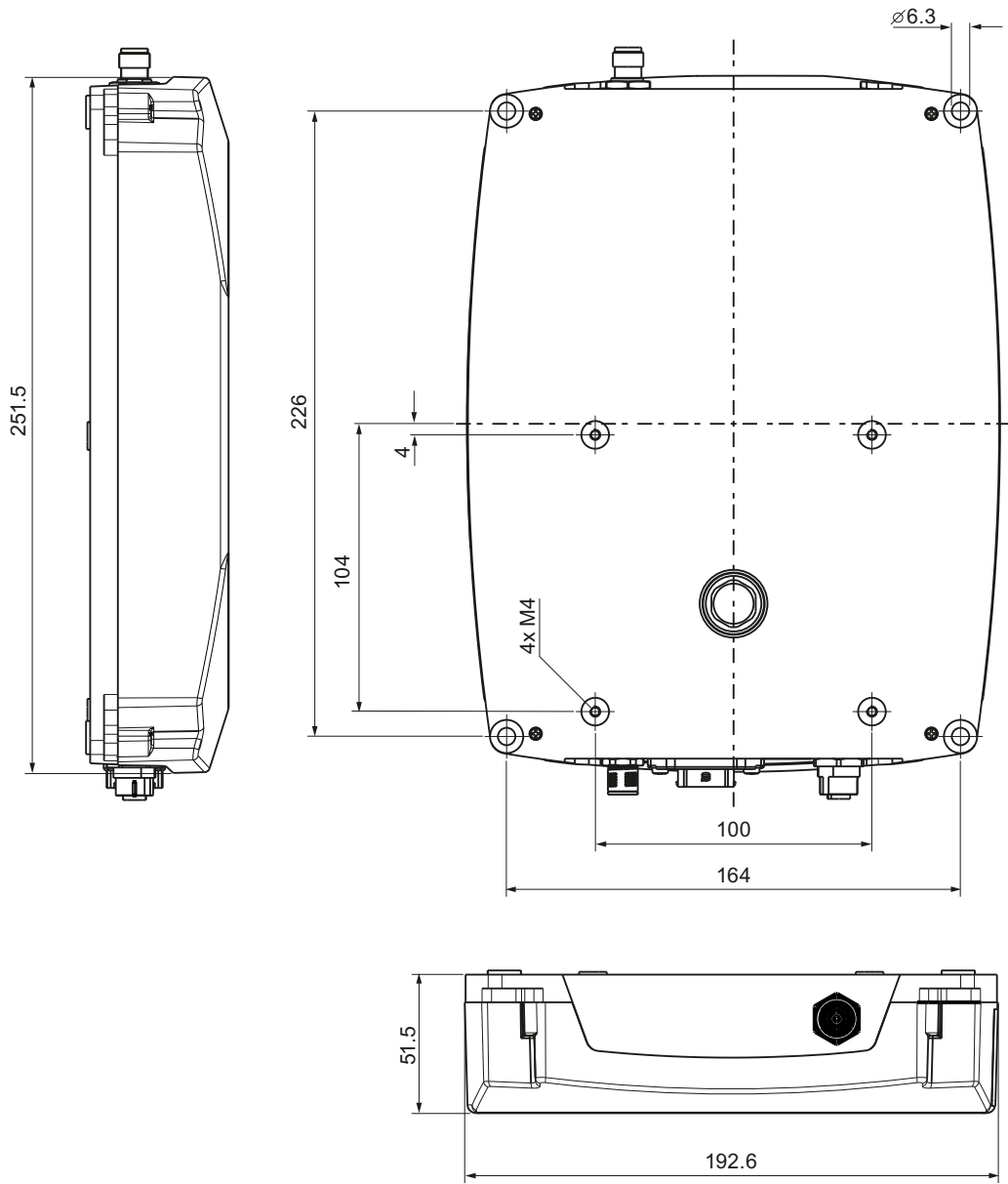

Figure 5-21 Dimensional drawing of RF640R
All dimensions in mm (± 0.5 mm tolerance)

5.3.7 Certificates and approvals

Note

Marking on the readers according to specific approval

The certificates and approvals listed here apply only if the corresponding mark is found on the readers.

Table 5- 14 6GT2811-3BA00-0AA0

Certificate	Description
	Conformity with R&TTE directive

Table 5- 15 6GT2811-3BA00-1AA0



Standard	
 Federal Communications Commission	FCC CFR 47, Part 15 sections 15.247 Radio Frequency Interference Statement This equipment has been tested and found to comply with the limits for a Class A digital device, pursuant to Part 15 of the FCC Rules. FCC ID: NXW-RF600R
Industry Canada Radio Standards Specifications	RSS-210 Issue 6, Sections 2.2, A8 IC: 267X-RF600R, Model RF640R
	This product is UL-certified for the USA and Canada. It meets the following safety standard(s): UL 60950-1 - Information Technology Equipment Safety - Part 1: General Requirements CSA C22.2 No. 60950 -1 - Safety of Information Technology Equipment UL Report E 205089

Table 5- 16 6GT2811-3BA00-2AA1

Standard	
CMIIT Certification	China radio approval Marking on the reader: CMIIT ID:

5.3.7.1 FCC information

Siemens SIMATIC RF640R (FCC): 6GT2811-3BA00-1AA0

FCC ID: NXW-RF600R

This device complies with part 15 of the FCC rules.
Operation is subject to the following two conditions:

- (1) This device may not cause harmful interference, and
- (2) This device must accept any interference received, including interference that may cause undesired operation.

Caution

Any changes or modifications not expressly approved by the party responsible for compliance could void the user's authority to operate the equipment.

Note

This equipment has been tested and found to comply with the limits for a Class B digital device, pursuant to part 15 of the FCC Rules. These limits are designed to provide reasonable protection against harmful interference when the equipment is operated in a commercial environment. This equipment generates, uses, and can radiate radio frequency energy and, if not installed and used in accordance with the instruction manual, may cause harmful interference to radio communications. Operation of this equipment in a residential area is likely to cause harmful interference in which case the user will be required to correct the interference at his own expense.

FCC Notice

To comply with FCC part 15 rules in the United States, the system must be professionally installed to ensure compliance with the Part 15 certification.

It is the responsibility of the operator and professional installer to ensure that only certified systems are deployed in the United States. The use of the system in any other combination (such as co-located antennas transmitting the same information) is expressly forbidden.

FCC Exposure Information

To comply with FCC RF exposure compliance requirements, the antennas used for this transmitter must be installed to provide a separation distance of at least 20 cm from all persons and must not be co-located or operating in conjunction with any other antenna or transmitter.

5.3.7.2 IC-FCB information

Siemens SIMATIC RF640R (FCC): 6GT2811-3BA00-1AA0

IC 267X-RF600R, Model RF640R

Industry Canada Notice

To reduce potential radio interference to other users, the antenna type and its gain should be so chosen that the equivalent isotropically radiated power (e.i.r.p.) is not more than that permitted for successful communication.

Transmitter power and antenna information for antennas with a gain less than 6 dBi:

This device has been designed to operate with the SIMATIC RF620A antenna 902-928, the SIMATIC RF640A antenna 902-928 as well as the SIMATIC RF660A antenna 902-928 listed below, and having a maximum gain of 5,5 dBi. Arbitrary transmission power settings in combination with other antennas or antennas having a gain greater than 5,5 dBi are strictly prohibited for use with this device. The required antenna impedance is 50 Ohms.

Transmitter power and antenna information for antennas with a gain greater 6 dBi:

This device requires professional installation. Antennas with a gain greater 6 dBi may be used provided the system does not exceed the radiation power of 4000 mW E.I.R.P. This device has been designed to operate with the SIMATIC RF642A antenna 902-928 exceeding the maximum gain of 5,5 dBi under the restriction that the RF power at the input of the antenna must be set to meet the following relation: RF power (dBm) \leq 30 dBm – (antenna gain (dBi) – 6 dBi) Other antennas or system configurations for antennas having a gain greater than 6 dBi are strictly prohibited for use with this device. The required antenna impedance is 50 Ohms.

5.4 RF670R reader

5.4.1 Description

5.4.1.1 Overview

The SIMATIC RF670R is an active stationary reader in the UHF frequency range without an integrated antenna. Up to four external UHF RFID antennas can be connected via TNC reverse connections.

The maximum HF power output is 1000°W on the reader output. A radiant power of up to 2000 mW ERP is achieved when the appropriate antennas and antenna cables are used. The interfaces (Ethernet, M12 power supply, M12 digital I/O interface) are located along the narrow lower edge. These interfaces can be used to connect the reader to the power supply and the PC for parameterization.

The degree of protection is IP65.

	Pos.	Description
	(1)	TNC reverse interfaces for connecting up to four antennas
	(2)	LED status indicator
	(3)	24 VDC power supply
	(4)	Ethernet interface (TCP/IP)
	(5)	Digital I/O interface

Highlights

- The tags are read in accordance with the requirements of the EPC Global Class 1 Gen 2 or ISO/IEC 18000-6C standards
- Supports low-cost SmartLabels as well as reusable, rugged data media
- High reading speed: many tags can be read simultaneously (mass recording), rapidly moving tags are reliably recorded.
- The RF670R (ETSI) "6GT2811-0AB00-0AA0" is suitable for the frequency band 865 to 868°MHz UHF (EU, EFTA, Turkey). The reader supports the current standard ETSI EN 302 208 V1.2.1 (4-channel plan).
- The RF670R (FCC) "6GT2811-0AB00-1AA0" is suitable for the frequency band 902 to 928°MHz (North America).
- The RF670R (CMIIT) "6GT2811-0AB00-2AA0" is suitable for the frequency band 920.125 to 924.875°MHz.
- Up to four external antennas can be connected
- Antennas can be used separately for up to four independent reading points; several antennas can be combined to form one reading point
- IP65 degree of protection
- Can be used for a high temperature range
- Antenna switching for high tag reader probability
- Dense Reader Mode (DRM) for environments in which many readers are operated in close proximity to each other.
- System integration over Ethernet (TCP/IP)
- Digital I/Os: Industry-compatible with high output power levels
- Configurable switching of the digital outputs with reader-internal logic
- Data processing in the reader (filtering, smoothing, etc.)
- Additional information for each acquired RFID transponder (RSSI values, time stamp)

5.4.1.2 Ordering data

Ordering data for RF670R

Product	Order number
RF670R (ETSI) reader basic unit for EU, EFTA, Turkey	6GT2811-0AB00-0AA0
RF670R (FCC) reader basic unit for the USA	6GT2811-0AB00-1AA0
RF670R (CMIIT) reader basic unit for China	6GT2811-0AB00-2AA0

Ordering data for antennas and antenna cables

Product	Order number
Antennas <ul style="list-style-type: none"> • RF620A antenna for EU, EFTA, Turkey (868 MHz) • RF620A antenna for FCC (915 MHz) • RF640A antenna (865 to 928 MHz) • RF642A antenna (865 to 928 MHz) • RF660A antenna for EU, EFTA, Turkey (868 MHz) • RF660A antennas for the USA and China (915°MHz) 	<ul style="list-style-type: none"> • 6GT2812-1EA00 • 6GT2812-1EA01 • 6GT2812-0GA08 • 6GT2812-1GA08 • 6GT2812-0AA00 • 6GT2812-0AA01
Antenna cable <ul style="list-style-type: none"> • 3 m (cable attenuation: 1.0 dB) • 5 m (cable attenuation: 1.25 dB, suitable for drag chains) • 10 m (cable attenuation: 4.0 dB) • 10 m (cable attenuation: 2.0 dB) • 15 m (cable attenuation: 4.0 dB, suitable for drag chains) • 20 m (cable attenuation: 4.0 dB) 	<ul style="list-style-type: none"> • 6GT2815-0BH30 • 6GT2815-2BH50 • 6GT2815-0BN10 • 6GT2815-1BN10 • 6GT2815-2BN15 • 6GT2815-0BN20

Ordering data (accessories)

Product	Order number
Antenna mounting kit	6GT2890-0AA00
Connecting cable and connectors <ul style="list-style-type: none"> • Digital I/O, open cable ends, 5 m • Ethernet: 10 m (cross cable) • Ethernet connector on reader according to IEC PAS 61076-3-117IE RJ45 Plug PRO (IP67) • Ethernet connector, Standard IE FastConnect RJ45 Plug 180 (IP20) • Ethernet cable sold by the meter, green 	<ul style="list-style-type: none"> • 6GT2891-0CH50 • 6GT2891-1HN10 • 6GK1901-1BB10-6AA0 • 6GK1901-1BB10-2AB0 • 6XV1840-2AH10
Wide-range power supply unit for SIMATIC RF systems <ul style="list-style-type: none"> • With EU plug • With UK plug • With US plug 	<ul style="list-style-type: none"> • 6GT2898-0AA00 • 6GT2898-0AA10 • 6GT2898-0AA20
24 V connecting cable 5 m between reader and power supply (for RF670R only, pin assignment is PNO compatible)	6GT2891-0NH50

Product	Order number
Set of protective caps Contains 3 protective caps for antenna output and one protective cap for digital I/O interface (required for IP65 degree of protection when some connectors are unused)	6GT2898-4AA00
RFID DVD "Software & Documentation"	6GT2080-2AA20

5.4.1.3 Status display

The device is equipped with a three colored LED. The LED can be lit in green, red or orange. The meaning of the indication changes in accordance with the color and state (on, off, flashing) of the LED:

Green LED	Red LED	Orange LED	Meaning
Off	Off	Off	The device is not connected to a power supply.
Flashing	Off	Off	In normal operation, no communication with the reader has taken place for a longer period of time.
On	Off	Off	The device is ready. The connection is established.
Off	Off	Flashing	More than one tag is in the field.
Off	Off	On	The device is starting up. The connection is established. Exactly one tag is in the field during normal operation.
Off	Flashing	Off	Error states with flash codes (see section Flashing codes of the RF600 readers with Ethernet interface (Page 385))
Off	flashes 2x	Off	At the end of the startup

Note

LED is not lit orange?

If the LED does not light up orange even though a tag is located within the field, common causes are:

- Antenna is switched off
- A tag is used, that is not compatible with the reader protocol (EPC Global Class 1 Gen 2).
- Tag is defective
- Reader or antenna has a defect
- Tag is not in the field of radiation of the transmit antenna

For more detailed information on the flash codes of the reader see section Flashing codes of the RF600 readers with Ethernet interface (Page 385)

5.4.1.4 Pin assignment of the digital I/O interface

View of socket (reader end)

Table 5- 17

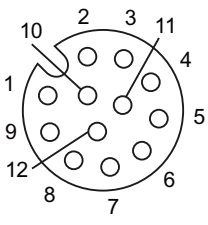
M12 socket (reader end)	Pin	Pin assignment
	1	GND (output for supply of digital inputs/outputs [not electrically isolated])
	2	VCC (output for supply of digital inputs/outputs [not electrically isolated])
	3	DO Common / Output Common
	4	DO 0 / Output 00
	5	DO 1 / Output 01
	6	DO 2 / Output 02
	7	DO 3 / Output 03
	8	DI 0 / Inport 00
	9	DI Common / Inport Common
	10	DI 1 / Inport 01
	11	DI 2 / Inport 02
	12	DI 3 / Inport 03

Wiring diagram M12 connector (cable end)

You will need to assemble your reader cable with a suitable connector that fits the interface shown above. Keep to the following wiring diagram:

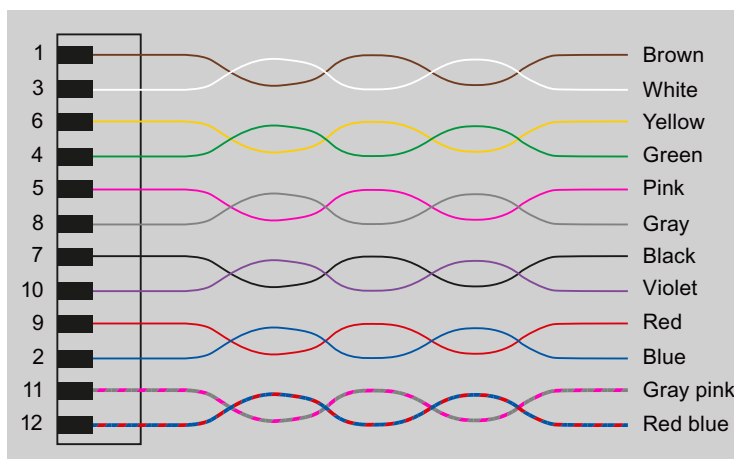

Figure 5-22 M12 connector wiring diagram

5.4.1.5 Connection scheme for the digital I/O interface

Connection possibilities

You can connect the RF670R reader in different ways. In general, the outputs and inputs should be connected as follows:

Output Output (0), (1), (2), (3)

- Each output is rated for 0.5 A current and is electronically protected.
- Four digital outputs can be operated simultaneously with up to 0.5 A each (up to 1.5 A in total).
- The outputs are optically isolated through optocouplers.

Input Inport (0), (1), (2), (3)

- The inputs are optically isolated through optocouplers.
- Level Low 0 ... 3 V; High 3,6 ... 24 V
- Sampling rate < 20 ms

The following diagrams illustrate various connection possibilities.

Voltage infeed through internal source (no electrical isolation)

Figure 5-23 Example circuit 1: Digital inputs

Alternative connection possibilities:

- Pin 2 (VCC) to Pin 9 DI Common
- Pin 1 GND to busbar inputs

Voltage infeed through external source

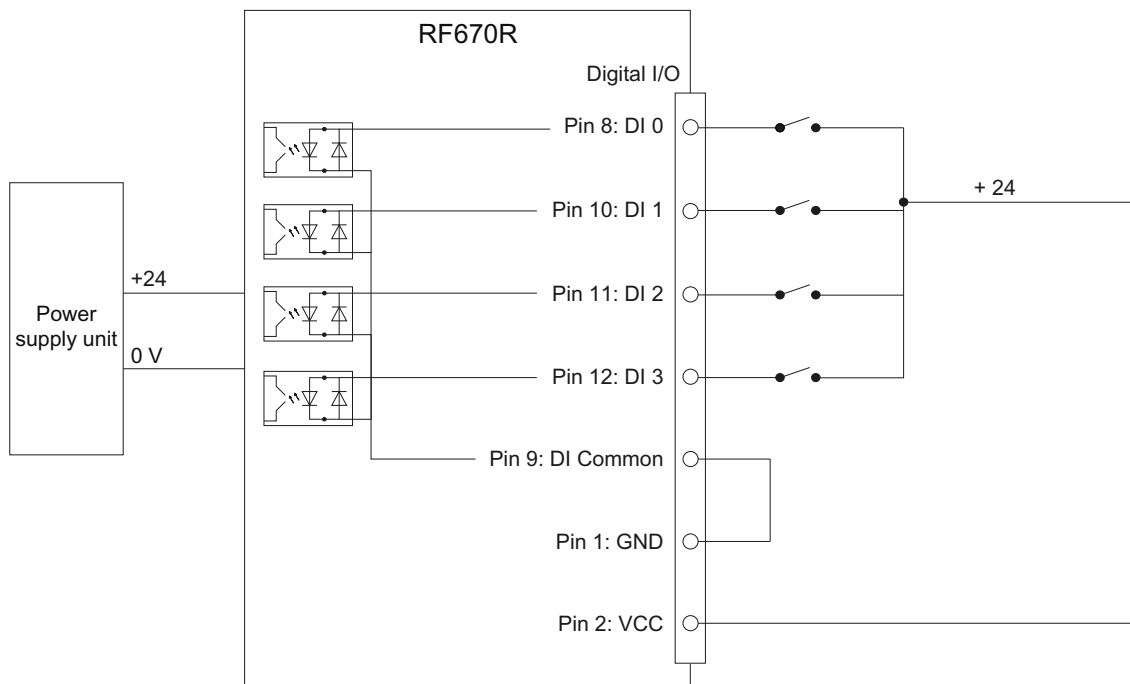
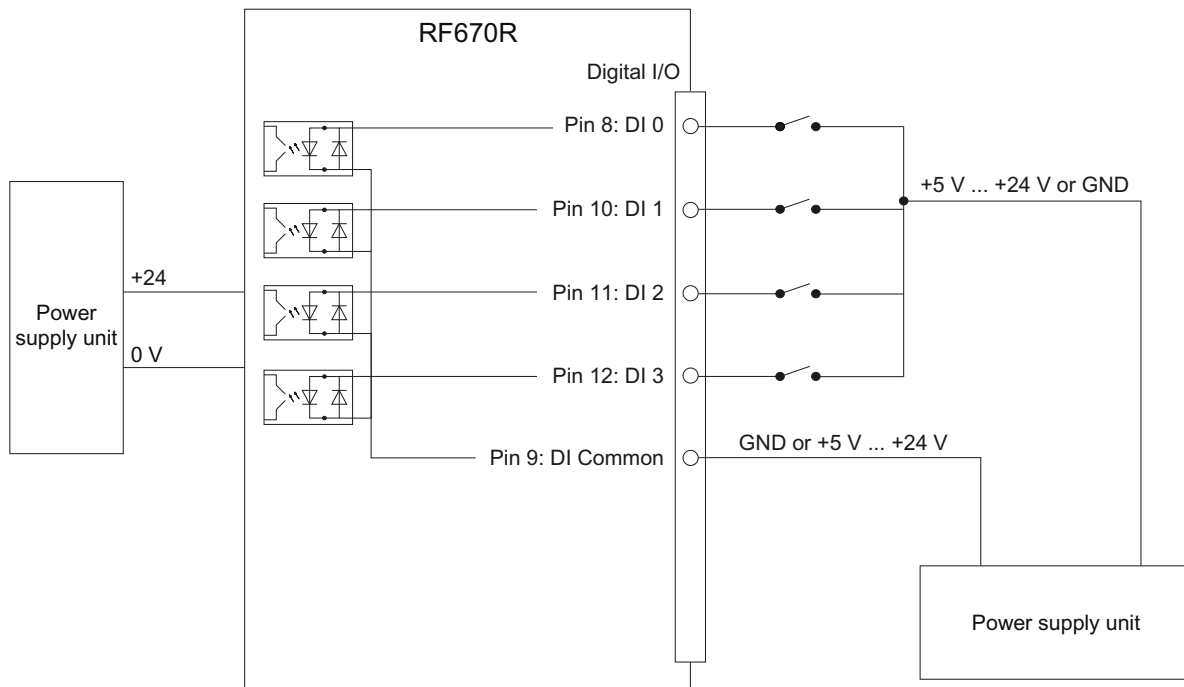

Figure 5-24 Example circuit 2: Digital inputs

Voltage infeed through external source with various voltages

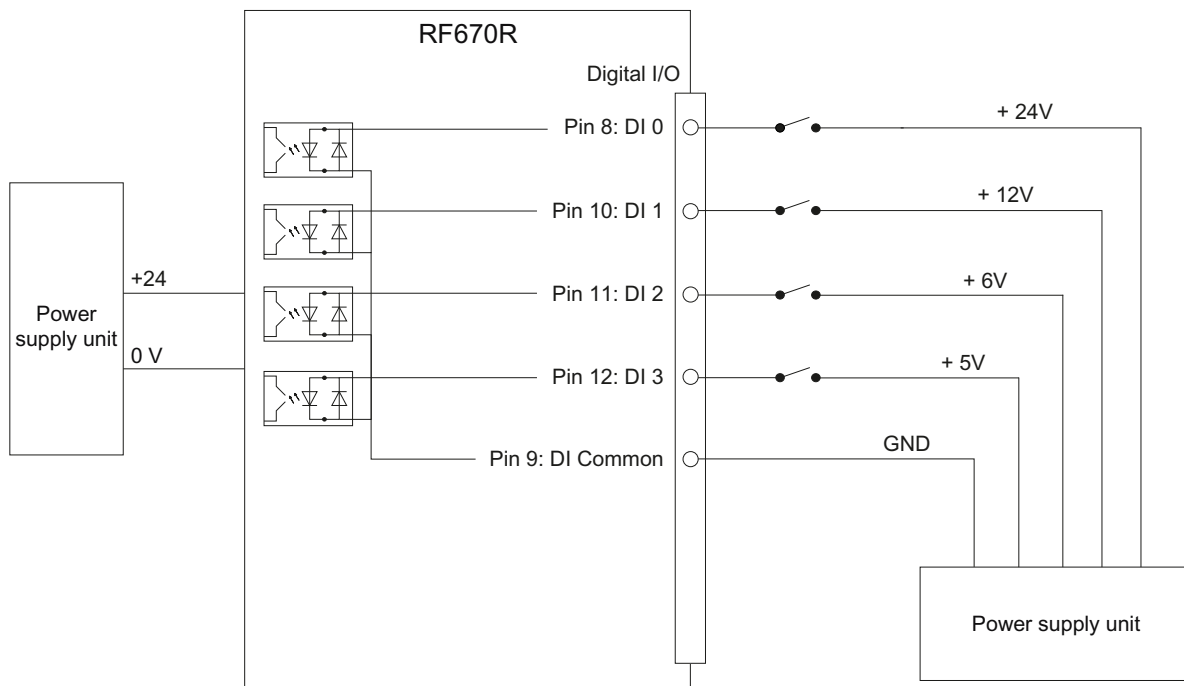

Figure 5-25 Example circuit 3: Digital inputs

Voltage infeed through internal source

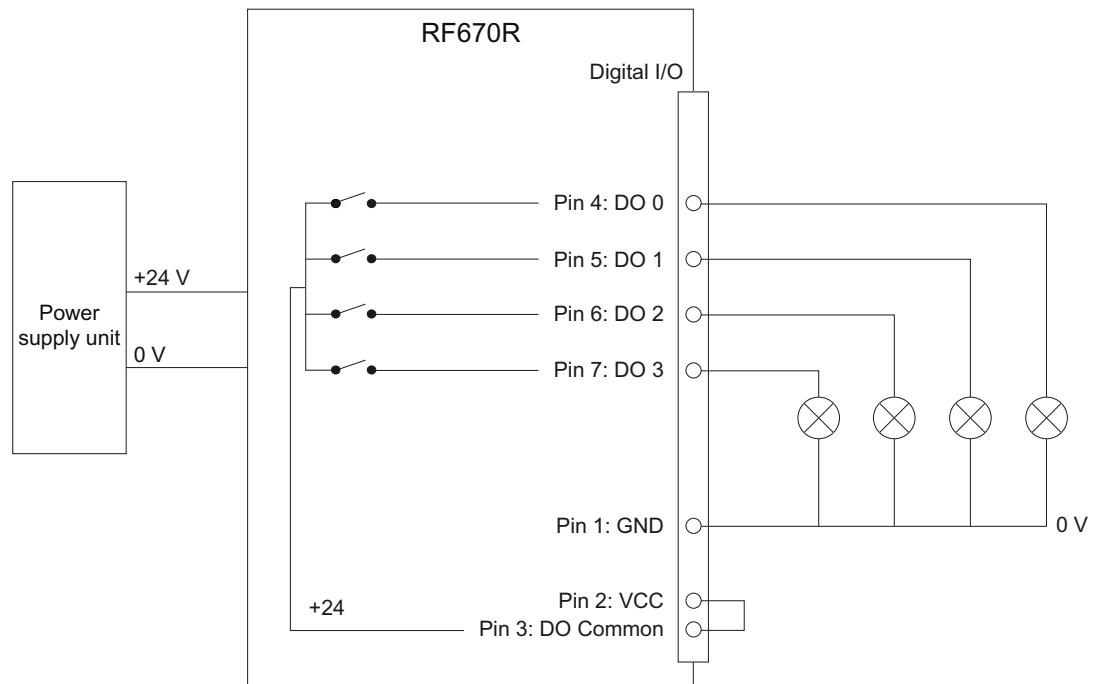

Figure 5-26 Example circuit 4: Digital outputs

Alternative connection possibilities:

- Pin 1 GND to Pin 3 DO Common
- Pin 2 (VCC) to busbar outputs

Voltage infeed through external source

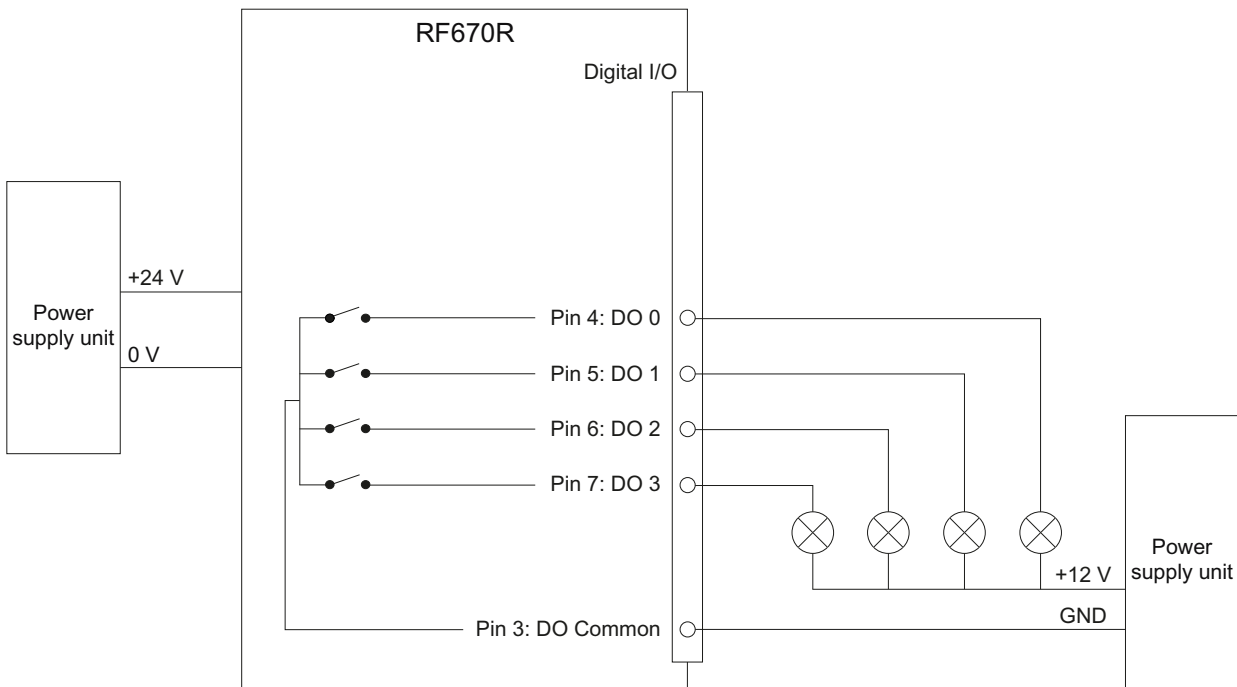

Figure 5-27 Example circuit 5: Digital outputs

Voltage infeed through an external source is shown here for 12°V by way of example. Other voltages are also permissible.

Voltage infeed through external source with various voltages

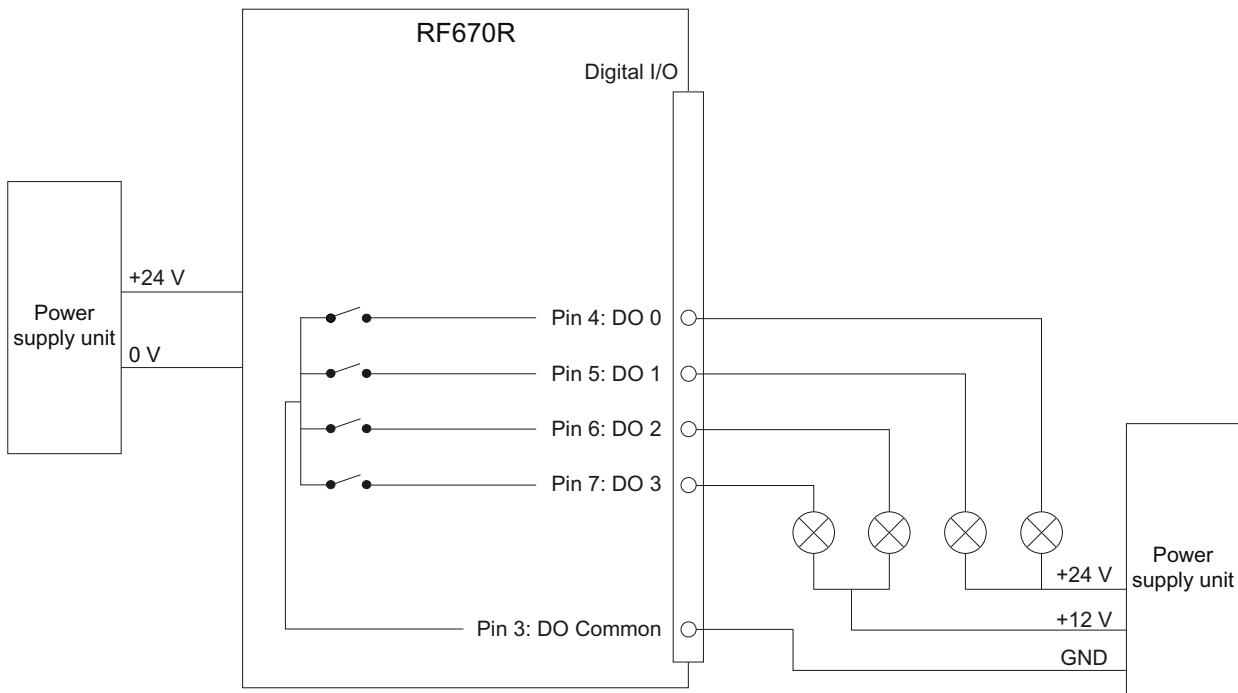

Figure 5-28 Example circuit 6: Digital outputs

5.4.1.6 Pin assignment for power supply

Pin assignment of the power connections

Power connector (on reader side)	Pin	Pin assignment
	1	24 VDC
	2	Not connected
	3	Ground (0 V)
	4	Not connected

The power connector of the RF670R is PNO compatible, i.e.° normal PROFINET IO connectors will fit this interface.

5.4.1.7 Pin assignment for Industrial Ethernet interface

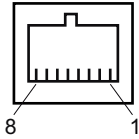
Industrial Ethernet (on reader side)	Pin	Pin assignment
	1	Transmit Data (+)
	2	Transmit Data (-)
	3	Receive Data (+)
	4	Terminated
	5	Terminated
	6	Receive Data (-)
	7	Terminated
	8	Terminated

NOTICE

We recommend that only original Siemens Ethernet crossover cables are used (10 m cable: Order No. 6GT2891-1HN10) or the Siemens connector (see Section Ordering data (Page 163)) for connecting to the Ethernet socket of the reader. If plug-in connectors from other manufacturers are used, it may be difficult or even impossible to remove the plug from the reader

Note

No autocrossover

The RF670R reader does not support autocrossover!

5.4.1.8 Grounding connection

The RF670R can be electrically connected to the ground potential through a contact washer. The tightening torque must be increased in this case to ensure that electrical contact is made (2.7 Nm).

⚠ WARNING

Hazardous voltage due to lightning strikes

Death or serious injury may occur as a result of lightning strikes to antennas mounted outside buildings.

If the reader is operated with antennas mounted outside buildings, it is imperative that the reader is electrically connected to the ground potential.

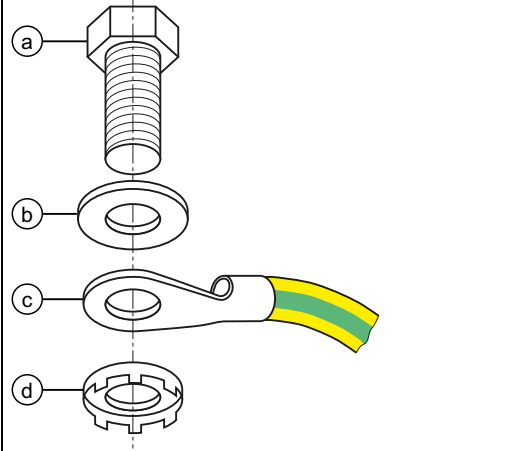
Ground connection	
	(a) Hexagon-head screw
	(b) Plain washer
	(c) Cable lug
	(d) Contact washer: Use contact washers according to the Siemens standard SN 70093-6-FSt-fINnc-480h for ground connection, Siemens item No.: H70093-A60-Z3

5.4.2 Planning the use

5.4.2.1 Antenna/read point configurations

You can connect up to four external antennas to the RF670R reader. The standard setting is that four antennas are connected when the reader is started. When connecting multiple antennas, note the information in the section "Specified minimum and maximum spacing of antennas (Page 45)".

With RF-MANAGER Basic V2 , you can set up various different configurations of antennas and/or reading points as required. It is possible to find solutions to many different tasks through the number of data sources and subsequent assignment of the antennas.

Examples of possible antenna reading point configurations

- Four data sources each with one antenna for four different reading points.
- Two data sources each with two antennas for small portals.
- One data source with 4 antennas for large portals.

You will find further information in the online Help for the products.

5.4.3 Installing / mounting

Requirement

 WARNING
Make sure that the wall or ceiling can hold four times the total weight of the device.

Note
Close unused connectors

If you do not use connectors on the reader, it is advisable to close the unused connectors with protective caps. You can order the protective cap set using the MLFB specified in the section "Ordering data".

 CAUTION
Emitted radiation The transmitter complies with the requirements of Health Canada and the FCC limit values for subjecting persons to HF radiation, provided that a minimum spacing of 26 cm exists between antenna and person. When the antennas are installed, you must therefore ensure that a minimum spacing of 26 cm is maintained between personnel and antennas.

Mounting/installing the device

- You can mount the reader in two different ways:
- Via a standardized VESA 100 mounting system using the Antenna Mounting Kit (see section Mounting with antenna mounting kit (Page 262)). Tighten the M4 screws on the rear of the reader using a maximum torque of ≤ 1.3 Nm.
 - Directly onto a flat surface.

The positions of the fixing holes for the device are shown in the section Dimension drawings (Page 179).

5.4.4 Configuration/integration

5.4.4.1 Configuration

An Ethernet interface is available for integrating the device into system environments/networks. Over the Ethernet interface and with direct connection to the PC, the RF670R can be configured in two different ways:

- Using RF-MANAGER Basic V2

The communication interface transfers the data over the RF-MANAGER Basic to the IT, ERP and SCM systems as well as to SIMATIC controllers. Alternatively the data is transferred to user applications by means of XML commands.

Simple process controls (e.g. a traffic signal) can be directly implemented using the write/read device via four digital inputs and outputs.

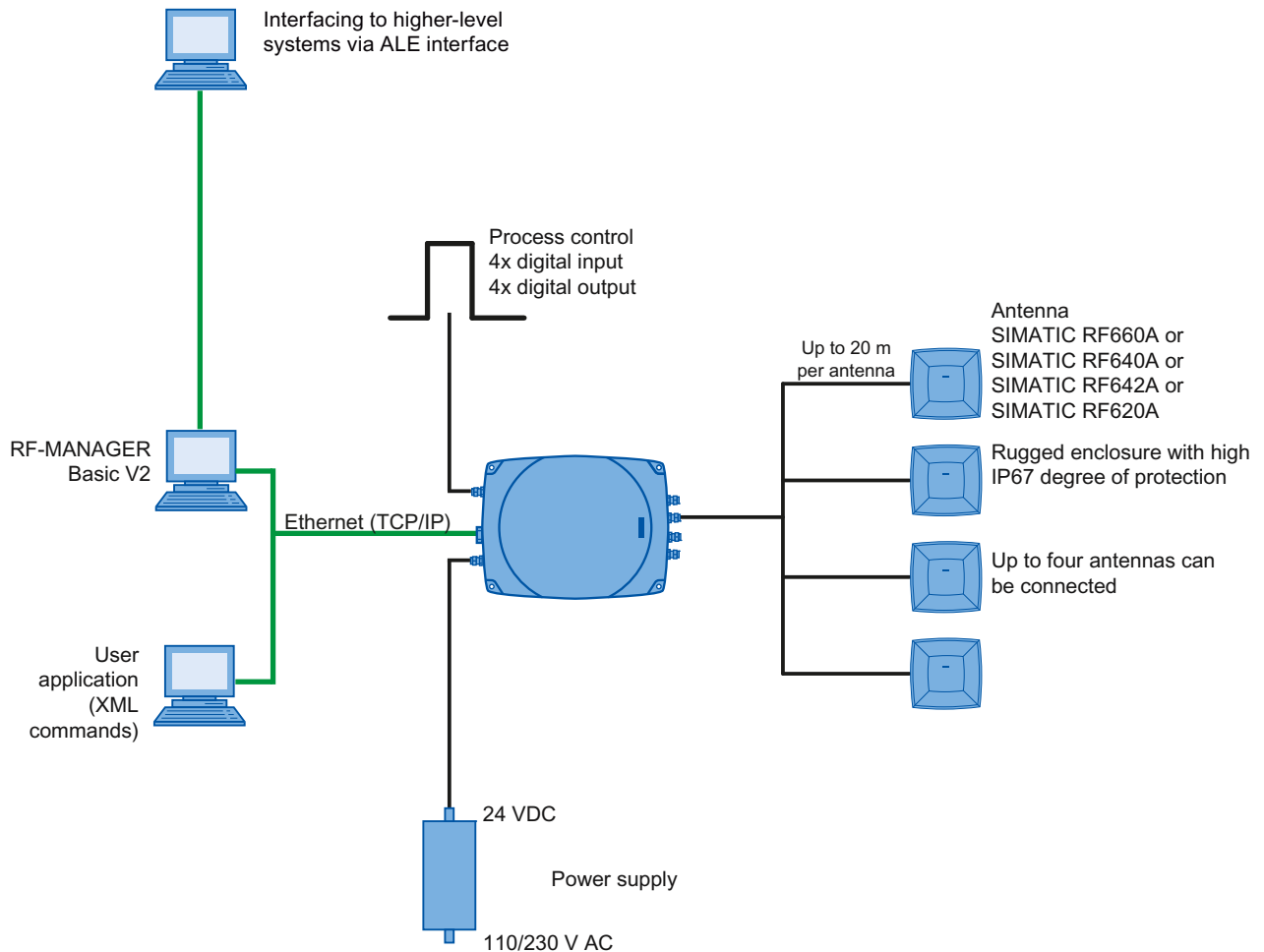

Figure 5-29 Overview of configuration of the RF670R reader

5.4.5 Technical data

5.4.5.1 Mechanical data

Mechanical data	
Weight	approx. 1800 g
Housing dimensions (L x W x H)	252 x 193 x 52 mm, without connections
Material for housing top section	ABS (GF 20)
Material for housing bottom section	Aluminum
Color of housing top section	Anthracite
Color of housing bottom section	Silver
Status displays on the device	1 LED Colors: red, yellow, green
Interfaces	
Antenna connectors	4x RTNC connector
Power supply	1 x plug (4-pin M12)
Digital I/O interface	1 x socket (12-pin M12)
Digital inputs	4
Digital outputs	4 (500 mA each; max. 1500 mA in total)
Ethernet	RJ-45 TCP/IP (push-pull) 10/100 Mbps
MTBF in years	16

Thermal and electrical properties			
Power supply		20 to 30 VDC ¹	
• Permitted range			
Power supply		Current consumption (in standby mode, no transmit power)	Power requirement (in standby mode, no transmit power)
	20 V input voltage on the reader, typical	140 mA	2.8 W
	24 V input voltage on the reader, typical	120 mA	2.88 W
	30 V input voltage on the reader, typical	100 mA	3.0 W
Power supply		Current consumption (at 1000 mW transmit power)	Power requirement (at 1000 mW transmit power)
	20 V input voltage on the reader, typical	530 mA	10.6 W
	24 V input voltage on the reader, typical	450 mA	10.8 W
	30 V input voltage on the reader, typical	370 mA	11.1 W
Rampup time		19 s	

¹⁾ All supply and signal voltages must be safety extra low voltage (SELV/PELV according to EN 60950)

24 VDC supply: safe (electrical) isolation of extra-low voltage (SELV / PELV acc. to EN 60950)

Mechanical environmental conditions	
Shock resistant acc. to EN 60068-2-27	50 g ¹
Vibration acc. to EN 60068-2-6	20 g ¹
Climatic conditions	
Ambient temperature during operation	-25 °C to +55 °C (a 10-minute warm-up time must be allowed at an operating temperature below -20 °C)
Ambient temperature for transport and storage	-40 °C to +85 °C

1) The values for shock and vibration are maximum values and must not be applied continuously.

EMC & approvals/conformity for ETSI variant	
Electromagnetic compatibility	ETSI EN 301 489-1 / -3 EN 302 208 V1.3.1 EN 302 208 V1.4.1
Approvals/Conformity	<ul style="list-style-type: none"> • Radio according to the R&TTE directive • CE • ETSI EN 302 208 V1.3.1 • ETSI EN 302 208 V1.4.1 • Reader degree of protection acc. to EN 60529 (IP65) • RoHS-compliant according to EU Directive 2002/95/EC • Human exposure

EMC & approvals for FCC variant	
Electromagnetic compatibility	FCC Part 15
Approvals	<ul style="list-style-type: none"> • FCC, cULus • IEC60950, including US and Canadian variants of it • Reader degree of protection acc. to EN 60529 (IP65) • FCC CFR47 Part 15.247 • RoHS-compliant according to EU Directive 2002/95/EC • Industrial Canada, RSS-210, Issue 7, June 2007

5.4.5.2 Technical data according to EPC and ISO

Technical specifications	
Frequency accuracy	max.± 10 ppm
Channel spacing	EU, EFTA, Turkey: 200 kHz US: 500 kHz China: 250 kHz
Modulation methods	ASK: DSB modulation & PR-ASK modulation Encoding, Manchester or Pulse Interval (PIE)
Effective radiated power	<ul style="list-style-type: none"> • ETSI/CMIT: • FCC: <ul style="list-style-type: none"> • ≤ 2 W ERP • ≤ 4 W EIRP
Transmit power	<ul style="list-style-type: none"> • ETSI/CMIT: • FCC: <ul style="list-style-type: none"> • ≤ 1.0 W • ≤ 1.25 W

Reading range	
Antennas mounted on opposing sides (portal configuration)	max. 10 m
Antennas mounted on the same side	max. 5 m (dependent on transponder)

ETSI frequencies	
Frequency range for Europe, EFTA, Turkey, South Africa ETSI EN 302 208 V1.3.1 (valid since August 10, 2010, publication in the Official Journal of the European Union)	865,7 ... 867.5 MHz (4 channels LBT optional at max. 2 W ERP)
Frequency range India	865 ... 860 MHz (10 channels at max. 4 W EIRP)
Frequency range Russia	866 ... 867 MHz (8 channels at 2 W ERP)
Frequency range Singapore	866 ... 869 MHz (11 channels at 0.5 W ERP)

FCC frequencies	
Frequency range USA; Argentina, Bolivia, Canada, Mexico	902 ... 928 MHz (50 channels at max. 4 W EIRP, frequency hopping)
Frequency range Brazil	515,25 ... 527.75 MHz (26 channels at max. 4 W EIRP, frequency hopping)
Frequency range South Korea	917,3 ... 920.3 MHz (7-16 channels at max. 4 W EIRP, frequency hopping)
Frequency range Thailand	920.25 ... 924.75 MHz (10 subchannels at max. 4 W ERP, frequency hopping)

Frequencies CMIT	
Frequency range China	920,625 ... 924.375 MHz (16 subchannels at 2 W ERP)

5.4.6 Dimension drawings

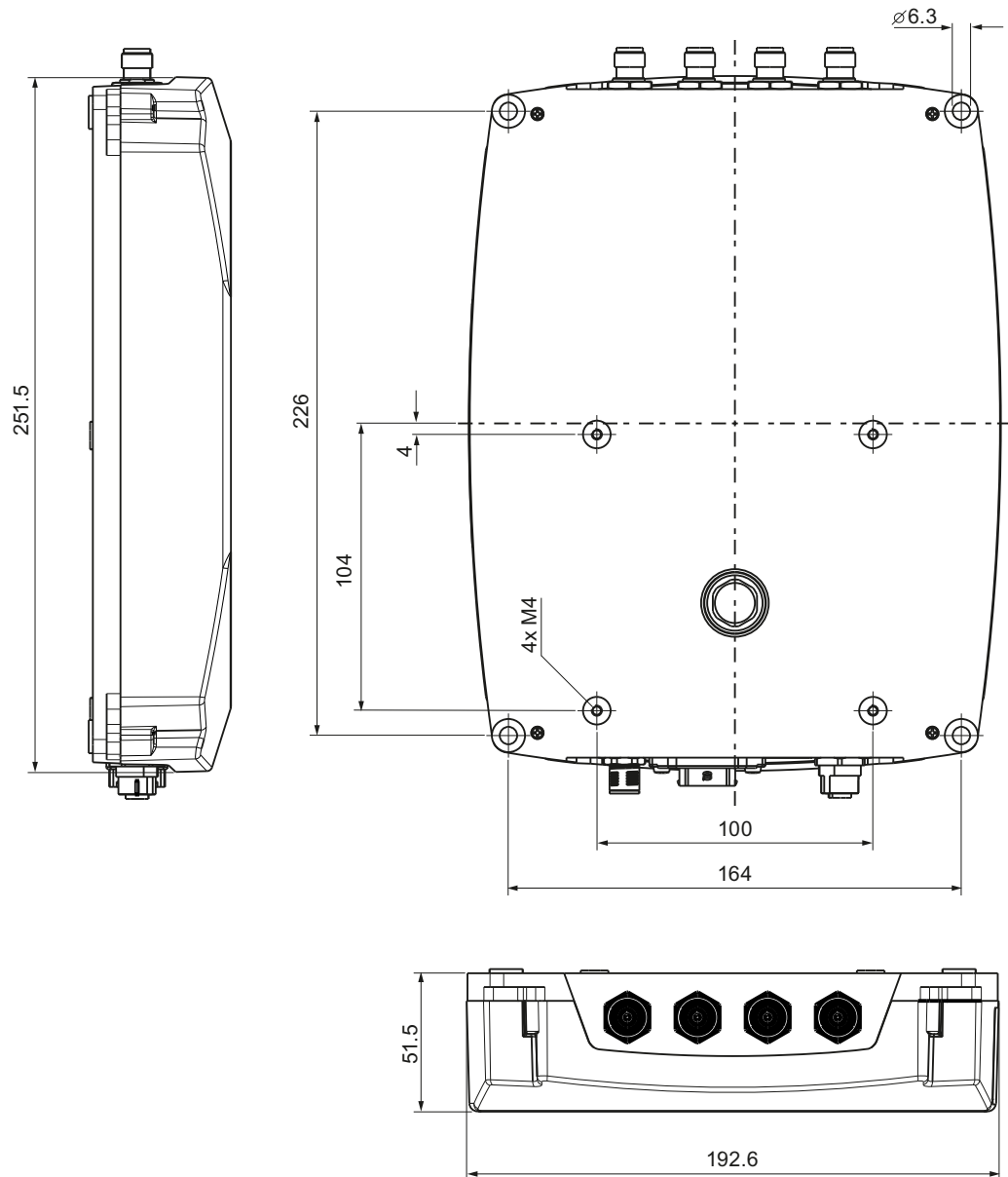

Figure 5-30 Dimension drawing for RF670R

All dimensions in mm (± 0.5 mm tolerance)

5.4.7 Certificates and approvals

Note

Marking on the readers according to specific approval

The certificates and approvals listed here apply only if the corresponding mark is found on the readers.

Table 5- 18 6GT2811-0AB00-0AA0



Certificate	Description
	Conformity with R&TTE directive

Table 5- 19 6GT2811-0AB00-1AA0

Standard	
 Federal Communications Commission	FCC CFR 47, Part 15 sections 15.247 Radio Frequency Interference Statement This equipment has been tested and found to comply with the limits for a Class B digital device, pursuant to Part 15 of the FCC Rules. FCC ID: NXW-RF670 (as of FS: A1) FCC ID: NXW-RF600R (as of FS: C1)
Industry Canada Radio Standards Specifications	RSS-210 Issue 7, June 2007, Sections 2.2, A8 IC: 267X-RF670 (as of FS: A1) IC: NXW-RF600R, model RF670R-2 (as of FS: C1)



Standard	
	<p>This product is UL-certified for the USA and Canada. It meets the following safety standard(s): UL 60950-1 - Information Technology Equipment Safety - Part 1: General Requirements CSA C22.2 No. 60950 -1 - Safety of Information Technology Equipment UL Report E 205089</p>
	<p>Brazil wireless approval Marking on the reader:</p> <div data-bbox="730 678 1417 965" style="border: 1px solid black; padding: 5px; text-align: center;"> <p>MODELO: RF670R 2270-11-4061</p>  <p>(01)07894607495719</p> </div> <p>Statement relating to approval: Este equipamento opera em caráter secundário, isto é, não tem direito à proteção contra interferência prejudicial, mesmo de estações do mesmo tipo e não pode causar interferência a sistemas operando em caráter primário. Certificate of the reader: ANATEL 2270-11-4061</p>

Table 5- 20 6GT2811-0AB00-2AA1

Standard	
CMIIT Certification	<p>China radio approval Marking on the reader: CMIIT ID: 2011DJ0748</p>

5.4.7.1 FCC information

Siemens SIMATIC RF670R (FCC): 6GT2811-0AB00-1AA0

FCC ID: NXW-RF670 (as of FS: A1)

FCC ID: NXW-RF600R (as of FS: C1)

This device complies with part 15 of the FCC rules.

Operation is subject to the following two conditions:

- (1) This device may not cause harmful interference, and
- (2) This device must accept any interference received, including interference that may cause undesired operation.

Caution

Any changes or modifications not expressly approved by the party responsible for compliance could void the user's authority to operate the equipment.

Note

This equipment has been tested and found to comply with the limits for a Class B digital device, pursuant to part 15 of the FCC Rules. These limits are designed to provide reasonable protection against harmful interference when the equipment is operated in a commercial environment. This equipment generates, uses, and can radiate radio frequency energy and, if not installed and used in accordance with the instruction manual, may cause harmful interference to radio communications. Operation of this equipment in a residential area is likely to cause harmful interference in which case the user will be required to correct the interference at his own expense.

FCC Notice

To comply with FCC part 15 rules in the United States, the system must be professionally installed to ensure compliance with the Part 15 certification.

It is the responsibility of the operator and professional installer to ensure that only certified systems are deployed in the United States. The use of the system in any other combination (such as co-located antennas transmitting the same information) is expressly forbidden.

FCC Exposure Information

To comply with FCC RF exposure compliance requirements, the antennas used for this transmitter must be installed to provide a separation distance of at least 20 cm from all persons and must not be co-located or operating in conjunction with any other antenna or transmitter.

5.4.7.2 IC-FCB information

Siemens SIMATIC RF670R (FCC): 6GT2811-0AB00-1AA0

IC: 267X-RF670 (as of FS: A1)

IC: NXW-RF600R, model: RF670R-2 (as of FS: C1)

Industry Canada Notice

To reduce potential radio interference to other users, the antenna type and its gain should be so chosen that the equivalent isotropically radiated power (e.i.r.p.) is not more than that permitted for successful communication.

Transmitter power and antenna information for antennas with a gain less than 6 dBi:

This device has been designed to operate with the SIMATIC RF620A antenna 902-928, the SIMATIC RF640A antenna 902-928 as well as the SIMATIC RF660A antenna 902-928 listed below, and having a maximum gain of 5,5 dBi.

Arbitrary transmission power settings in combination with other antennas or antennas having a gain greater than 5,5 dBi are strictly prohibited for use with this device.

The required antenna impedance is 50 Ohms.

Transmitter power and antenna information for antennas with a gain greater 6 dBi:

This device requires professional installation. Antennas with a gain greater 6 dBi may be used provided the system does not exceed the radiation power of 4000 mW E.I.R.P. This device has been designed to operate with the SIMATIC RF642A antenna 902-928 exceeding the maximum gain of 5,5 dBi under the restriction that the RF power at the input of the antenna must be set to meet the following relation: $\text{RF power (dBm)} \leq 30 \text{ dBm} - (\text{antenna gain (dBi)} - 6 \text{ dBi})$ Other antennas or system configurations for antennas having a gain greater than 6 dBi are strictly prohibited for use with this device. The required antenna impedance is 50 Ohms.

5.5 Reader RF680M

5.5.1 Description

SIMATIC RF680M expands the RF600 RF identification system with a powerful mobile reader for applications in the areas of logistics, production and service. In addition, it is an indispensable aid for startup and testing.

5.5.2 Field of application and features

Device variants for different frequency ranges

The SIMATIC RF680M device is available in two variants:

- For the European frequency ranges
- For the US frequency ranges

Implementation environment, field of application and features

- **Field of application**

The SIMATIC RF680M mobile reader can be used in a harsh environment. The device is extremely rugged and protected against spray water. The backlit display is easy to read even under unfavorable lighting conditions.

- **RFID system**

The SIMATIC RF680M mobile reader is intended especially for the SIMATIC RF600 RFID system. The device can be used to process all RF600 tags and compatible transponders.

- **Tag standards**

It is not possible to edit data memories of other RFID systems. The following tag standards are supported:

- ISO 18000-6c (EPC Class1 GEN2)

- **API software interface**

The SIMATIC RF680M Mobile Reader is supplied with an API software interface that can be used by customized user programs.

- **Additional functional units for the SIMATIC RF680M mobile reader**

All other functional units of SIMATIC RF680M, such as barcode scanners and WLAN can be accessed via the interfaces supplied by the PSION device manufacturer. The descriptions and development tools can be obtained from the PSION websites.

You can perform the following functions with the SIMATIC RF680M mobile reader:

Functions

- Reading the tag ID
- Reading the data from the tag (data memory)
- Writing the data to the tag
- Reading and displaying the ID number of the tag (Tag/Scan)
- Writing the tag ID to a transponder
- Displaying reader status
- Representing and editing the data in hexadecimal, ASCII and binary format
- Activatable/deactivatable password protection for all write functions and for terminating the program
- Menu prompting in English and German (switchable)
- Saving of the read-in RF600 data to files in the mobile reader. The mobile reader has approximately 900 MB available for this purpose.
- Easy creation of your own RFID applications with the Software Application Interface (API)

The RFID read/write unit of RF600 is integrated into the PSION basic unit.

You will find more detailed information on the RF680M mobile reader in the operating instructions of the SIMATIC RF680M Mobile Reader.

Antennas

6.1 Overview

The following table shows the most important features of the RF600 antennas at a glance:

Features	RF620A antenna 865-868	RF620A antenna 902-928	RF660A antenna 865-868	RF660A antenna 902- 928
Material	PA 12, silicon-free			
Frequency range	865-868 MHz	902-928 MHz	865-868 MHz	902-928 MHz
Impedance	50 Ohm nominal			
Antenna gain	-10...-5 dBi		7 dBi	6 dBi
VSWR (standing wave ratio)	2:1 max.			
Polarization	Linear		RH circular	
Radiating/receiving angle	Depending on the mounting surface		55° - 60°	60° - 75°
Connector	RTNC coupling		RTNC	
Mounting type	2 x M5 screws		4 screws M4 (VESA 100 mount system)	
Degree of protection	IP67			
Permitted ambient temperature	-25 °C to +75 °C			
Number of connectable antennas per reader				
RF620R	1 antenna			
Max. radiated power	80 mW ERP / 130 mW EIRP		1000 mW ERP	2000 mW EIRP
RF630R	1 or 2 antennas			
Max. radiated power	80 mW ERP / 130 mW EIRP		1000 mW ERP	2000 mW EIRP
RF640R	1 antenna			
Max. radiated power	100 mW ERP / 300 mW EIRP		2000 mW ERP	4000 mW EIRP
RF670R	1, 2, 3 or 4 antennas			
Max. radiated power	100 mW ERP / 300 mW EIRP		2000 mW ERP	4000 mW EIRP

Features	RF640A antenna		RF642A antenna	
Material	PA 12, silicon-free			
Frequency range	865-868 MHz	902-928 MHz	865-868 MHz	902-928 MHz
Impedance	50 Ohm nominal			
Antenna gain	4 dBi (7 dBic)	4.3 dBi (7.3 dBic)	6 dBi	7 dBi
VSWR (standing wave ratio)	Max. 1.25	Max. 1.6	Max. 1.4	
Polarization	RH circular		Linear	
Radiating/receiving angle	Horiz. plane: 80°	Horiz. plane: 75°	Horiz. plane: 75°	Horiz. plane: 80°
	Vertic. plane: 75°	Vertic. plane: 85°	Vertic. plane: 70°	Vertic. plane: 70°
Connector	RTNC coupling		RTNC coupling	
Mounting type	4 screws M4 (VESA 100 mount system)			
Degree of protection	IP67			
Permitted ambient temperature	-25 °C to +75 °C			
Number of connectable antennas per reader				
	RF620R	1 antenna		
Max. radiated power	< 610 mW ERP	≤1070 mW EIRP	< 1000 mW ERP	2000 mW EIRP
	RF630R	1 or 2 antennas		
Max. radiated power	< 610 mW ERP	≤1070 mW EIRP	< 1000 mW ERP	2000 mW EIRP
	RF640R	1 antenna		
Max. radiated power	≤1300 mW ERP	≤2700 mW EIRP	2000 mW ERP	4000 mW EIRP
	RF670R	1, 2, 3 or 4 antennas		
Max. radiated power	≤1300 mW ERP	≤2700 mW EIRP	2000 mW ERP	4000 mW EIRP

6.2 RF620A antenna

6.2.1 Description

SIMATIC RF620A	Features	
	Field of application	<p>The SIMATIC RF620A is an antenna of compact, industry-standard design.</p> <p>It is suitable for UHF transponders with normal (far field) antenna characteristics, e.g. SIMATIC RF630L, SIMATIC RF620T.</p>
	Antenna field	<p>Designed for transponders that are uniformly aligned whilst directed past the antenna.</p> <p>See section Alignment of transponders to the antenna (Page 194)</p>
	Writing/reading range	<p>Approx. 0.5 m depending on the transponder (see section Read/write ranges (Page 203))</p>
	Connecting cable	<p>30 cm movable connecting cable and RTNC coupling (an antenna cable, e.g. 6GT2815-0BH30 is required for connection to the reader)</p>
	Readers that can be connected	<ul style="list-style-type: none"> • RF670R (1 to 4 antennas) • RF630R (1 or 2 antennas)
	Polarization	Linear
	Degree of protection	IP67

Frequency bands

The antenna is available for two different frequency ranges that have been specified for the regions of Europe, and China, USA respectively.

- The antenna for Europe operates in the frequency range from 865 to 868 MHz.
- The antenna for China and the USA operates in the frequency range from 902 to 928 MHz.

Function

The SIMATIC RF620A is used for transmitting and receiving RFID signals in the UHF frequency range. The antennas are connected to the SIMATIC RF600 readers via antenna cables that are available in different lengths.

6.2.2 Ordering data

Table 6- 1 Ordering data RF620A

Product	Order no.
SIMATIC RF620A (ETSI)	6GT2812-1EA00
SIMATIC RF620A (FCC)	6GT2812-1EA01

Accessories

Table 6- 2 Ordering data (accessories)

Product	Order no.	
Connecting cable between reader and antenna	3 m (cable loss 1.0 dB)	6GT2815-0BH30
	5 m, suitable for drag chains (cable loss 1.25 dB)	6GT2815-2BH50
	10 m (cable loss 2.0 dB)	6GT2815-1BN10
	10 m (cable loss 4.0 dB)	6GT2815-0BN10
	15 m, suitable for drag chains (cable loss 4.0 dB)	6GT2815-2BN15
	20 m (cable loss 4.0 dB)	6GT2815-0BN20

6.2.3 Installation and assembly

6.2.3.1 RF620A mounting types

Two holes for M5 screws are provided for mounting the antenna. This is therefore suitable for:

- Mounting on metallic and non-metallic backgrounds

Note

To achieve optimum wave propagation, the antenna should not be surrounded by conducting objects. The area between antenna and transponder should also allow wave propagation without interference.

6.2.4 Connecting an antenna to the reader

6.2.4.1 Overview

The SIMATIC RF620A antenna must be connected to the reader using an antenna cable.

Requirement

Note

Use of Siemens antenna cable

To ensure optimum functioning of the antenna, it is recommended that a Siemens antenna cable is used in accordance with the list of accessories.

Strain relief

The antenna cable is provided with strain relief as shown in the following diagram:

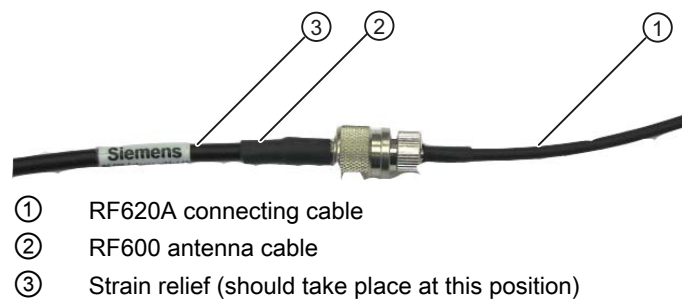

Figure 6-1 Strain relief

Bending radii and bending cycles of the cable

Cable designation	Order no.	Length [m]	Cable loss [dB]	Bending radius [mm]	Bending cycle
RF620A connecting cable				15	1 Mal
Antenna cable	6GT2815-0BH30	3	1	51	1 Mal
Antenna cable, suitable for drag chains	6GT2815-2BH50	5	1,25	48	1) ¹⁾
Antenna cable	6GT2815-1BN10	10	2	77	1 Mal
Antenna cable	6GT2815-0BN10	10	4	51	1 Mal
Antenna cable, suitable for drag chains	6GT2815-2BN15	15	4	24	1) ¹⁾
Antenna cable	6GT2815-0BN20	20	4	77	1 Mal

1) With cables suitable for drag chains, 3 million bending cycles at a bending radius of 6.5 m and bending through $\pm 180^\circ$ are permitted.

6.2.4.2 Connecting RF620A to an RF600 reader

Preassembled standard cables in lengths of 3 m, 5 m, 10 m, 15 m and 20 m are available to connect the antenna.

The read range is limited by the cable loss. The maximum range can be achieved with the 6GT2815-0BH30 cable (length 3 m) since this has the lowest cable loss.

Connection of one antenna

When one antenna is used, we recommend that you close the remaining antenna connector on the RF600 reader using the supplied protective cap.

Connection of two antennas

When using two antennas on the RF600 readers, there are no limitations regarding its positioning.

Note

Protective cap

If you use the internal antenna of the reader, we recommend that you close the external, unused antenna connector on the reader using the supplied protective cap.

6.2.5 Parameter settings of RF620A for RF620R/RF630R

Operation within the EU, EFTA, or Turkey according to EN 302 208 V1.3.1

NOTICE
Limitation of the radiated power according to EN 302 208 V1.3.1
RF600 systems that are put into operation within the EU, EFTA, or Turkey (ETSI) can be operated with an RF640A antenna with a maximum radiated power of up to 2000 mW ERP (or 33 dBm ERP, 3250 mW EIRP, 35 dBm EIRP).

By adjusting the transmit power of up to 500 mW ERP (or 27 dBm ERP, 800 mW EIRP, 29.15 dBm EIRP) and taking into account the RF620A antenna gain of -5 dBi and the cable loss associated with the antenna cable, the radiated power of the antenna cannot be exceeded. You can make the power settings using the "distance_limiting" parameter. You will find more detailed information on the parameters in the section Parameter assignment manual RF620R/RF630R (<http://support.automation.siemens.com/WW/view/en/33287195>).

Operation in China

The national approval for RF600 systems in China requires a cap of 2000 mW ERP (or 33 dBm ERP, 3250 mW EIRP, 35 dBm EIRP). The possible combination of antenna gain, cable loss, and max. 500 mW radiated power of the RF630R reader means it is not possible to exceed 2000 mW ERP (or 33 dBm ERP, 3250 mW EIRP, 35 dBm EIRP).

Operation in the USA, Canada

NOTICE
<p>Limitation of the radiated power to 4000 mW EIRP (36 dBm EIRP)</p> <p>So that the FCC and IC-FCB requirements are met, the radiated power may not exceed 4000 mW EIRP (36 dBm EIRP). Therefore the system must satisfy the following relation:</p> <ul style="list-style-type: none"> • Conducted power P dBm of the RF600 reader (< 30 dBm) • Antenna gain G_i dBi in the FCC frequency band (≤ 4.3 dBi) • Cable loss a_k dB (≥ 1 dB) <p>$P(\text{dBm}) \leq 30 \text{ dBm} - (G_i - 6 \text{ dBi}) + a_k$</p>

Due to the low antenna gain of -5 dB and the maximum transmit power of 500 mW of the reader, the maximum permitted radiated power cannot be exceeded.

6.2.6 Parameter settings of RF620A for RF640R/RF670R

Operation within the EU, EFTA, or Turkey

NOTICE
<p>Limitation of the radiated power according to EN 302 208 V1.3.1</p> <p>RF600 systems that are put into operation within the EU, EFTA, or Turkey (ETSI) can be operated with an RF640A antenna with a maximum radiated power of 2000 mW ERP (or 33 dBm ERP, 3250 mW EIRP, 35 dBm EIRP).</p>

By adjusting the radiated power of up to 70 mW ERP (or 18.85 dBm ERP, 120 mW EIRP, 21 dBm EIRP), the RF620A antenna gain of -5 dBi and the cable loss associated with the antenna cable, the radiated power of the reader is correctly configured and the radiated power at the antenna is not exceeded.

Operation in China

By setting a max. radiated power of 1300 mW ERP 70 mW ERP (or 18.85 dBm ERP, 120 mW EIRP, 21 dBm EIRP), the RF620A antenna gain of -5 dBi (-2 dBic) and the cable loss associated with the antenna cable, the corresponding transmit power of the reader is correctly configured.

Operation in the USA, Canada

NOTICE
Limitation of the radiated power to 4000 mW EIRP (36 dBm EIRP)
So that the FCC and IC requirements are met, the radiated power may not exceed 4000 mW EIRP (36 dBm EIRP). Therefore the system must satisfy the following relation:
<ul style="list-style-type: none">• Conducted power P dBm of the RF600 reader (< 30 dBm)• Antenna gain G_i dBi in the FCC frequency band (≤ 4.3 dBi)• Cable loss a_k dB (≥ 1 dB)
$P(\text{dBm}) \leq 30 \text{ dBm} - (G_i - 6 \text{ dBi}) + a_k$

Due to the low antenna gain of -5 dB and the maximum transmit power of 500 mW of the reader, the maximum permitted radiated power cannot be exceeded.

6.2.7 Alignment of transponders to the antenna

Polarization axis

Since the RF620A antenna has linear polarization, it is necessary to consider the alignment of the transponders with regard to the polarization axis of the antenna.

The polarization axes of antenna and transponder must always be parallel. The symbol on the antenna indicates the polarization axis.



Figure 6-2 Polarization axis

Alignment

The following diagram shows the optimum alignment of the RF600 transponders to the RF620A antenna.

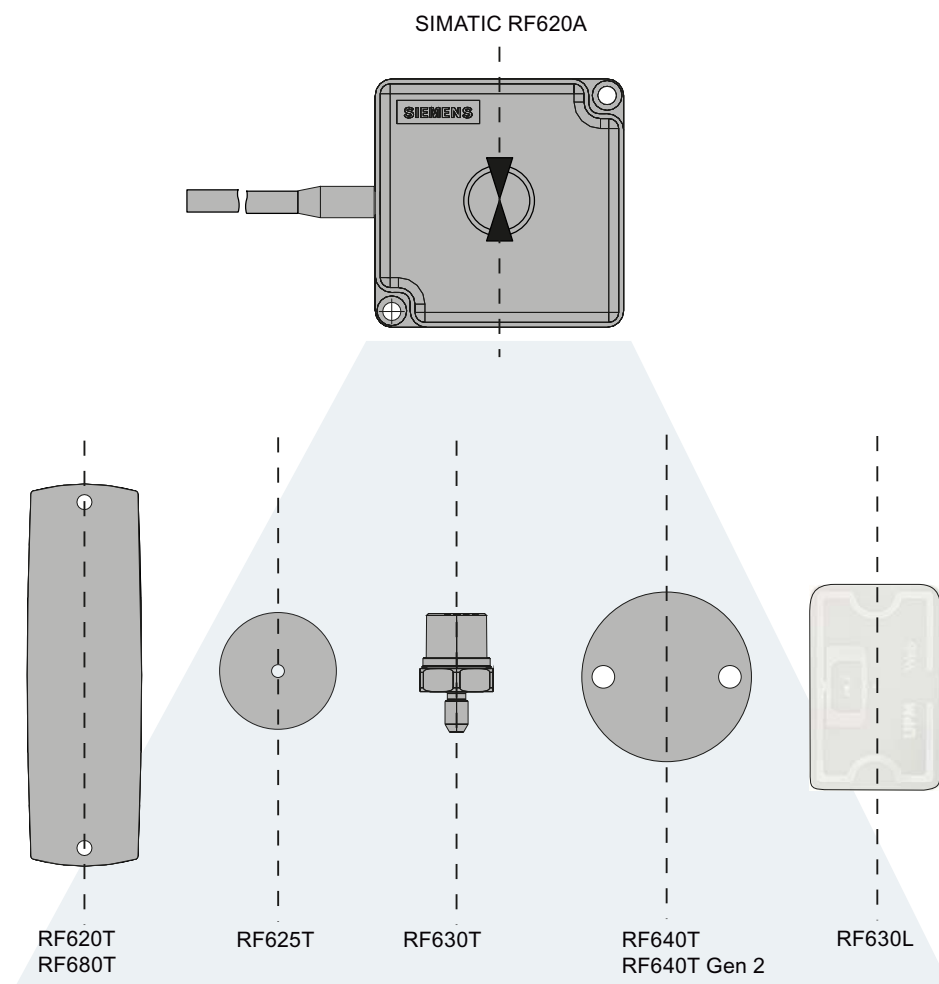

Figure 6-3 Antenna/transponder alignment

Angle deviation diagram for alignment

The following diagram shows the dependence of the following factors.

- Alignment angle of transponder to antenna
- Maximum range of antenna

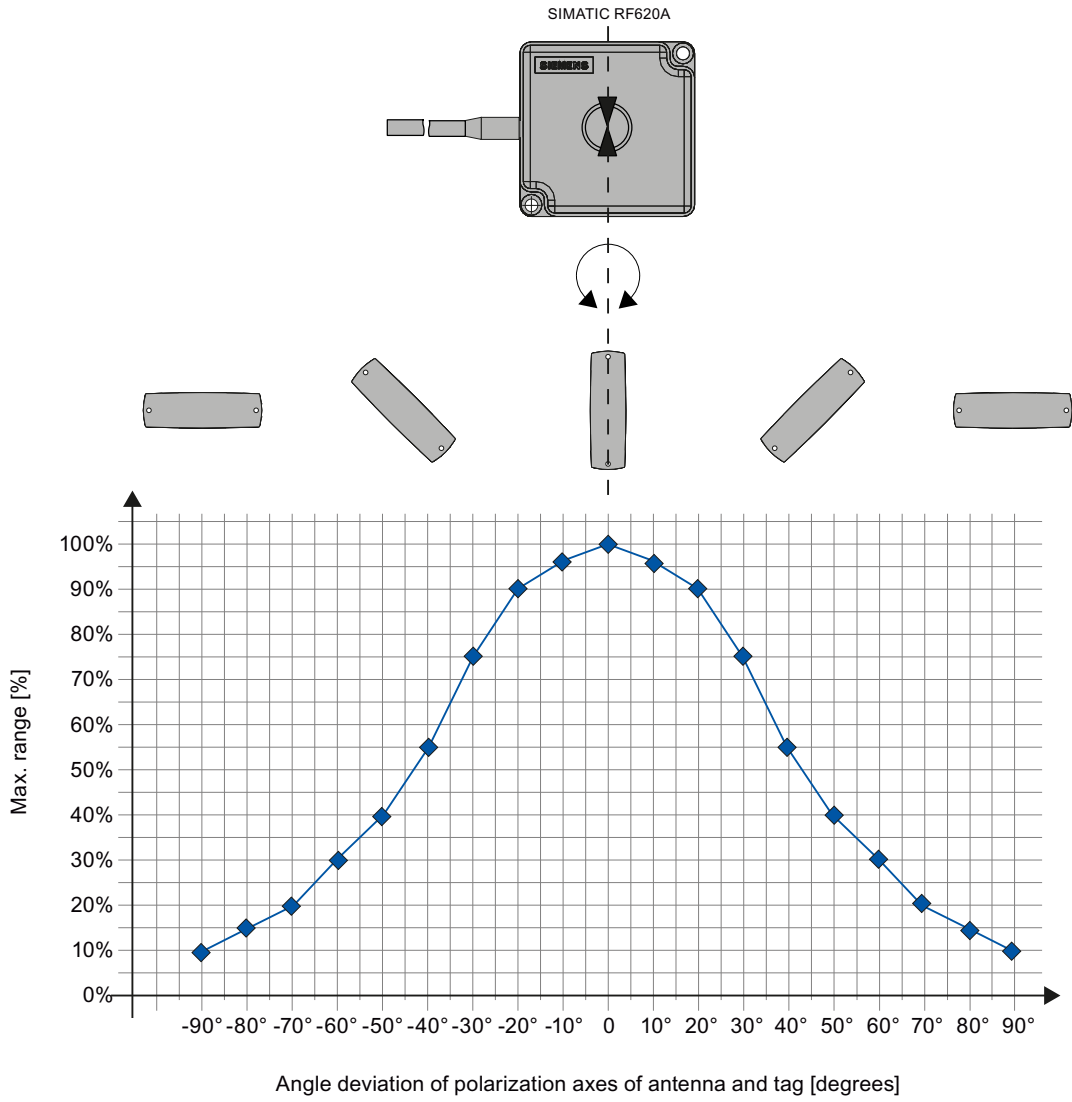

Figure 6-4 Angle deviation diagram for alignment

6.2.8 Antenna patterns

6.2.8.1 Antenna pattern ETSI

Directional radiation pattern Europe (ETSI)

The directional radiation pattern is shown for nominal alignment and a center frequency of 866.3 MHz. The nominal antenna alignment is given when the antenna elevation is provided as shown in the following figure.

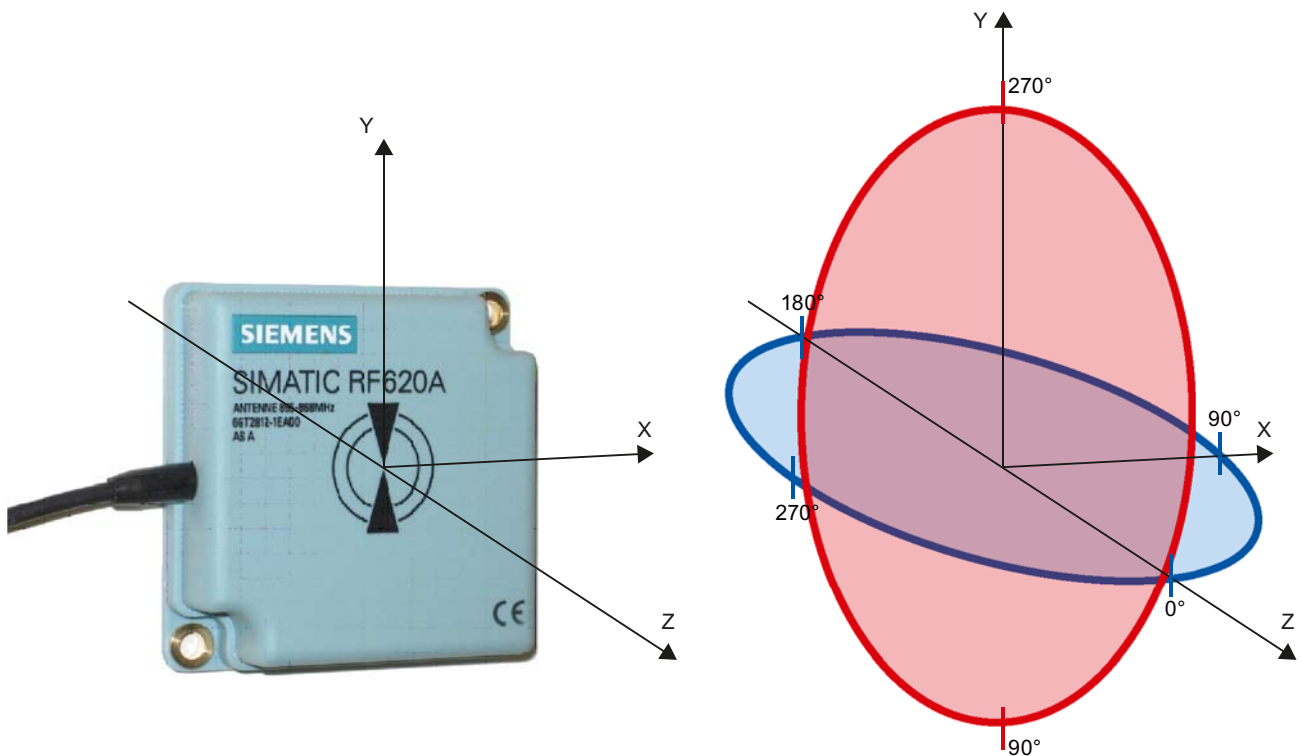

Figure 6-5 Reference system

The half-power beamwidth of the antenna is defined by the angle between the two -3 dB points. Which range (in %) corresponds to the dB values in the patterns can be obtained from this table .

Note that the measurements presented graphically below were carried out in a low-reflection environment. Deviations can therefore occur in a normally reflecting environment.

Directional radiation pattern ETSI on metallic mounting surface (15 cm x 15 cm)

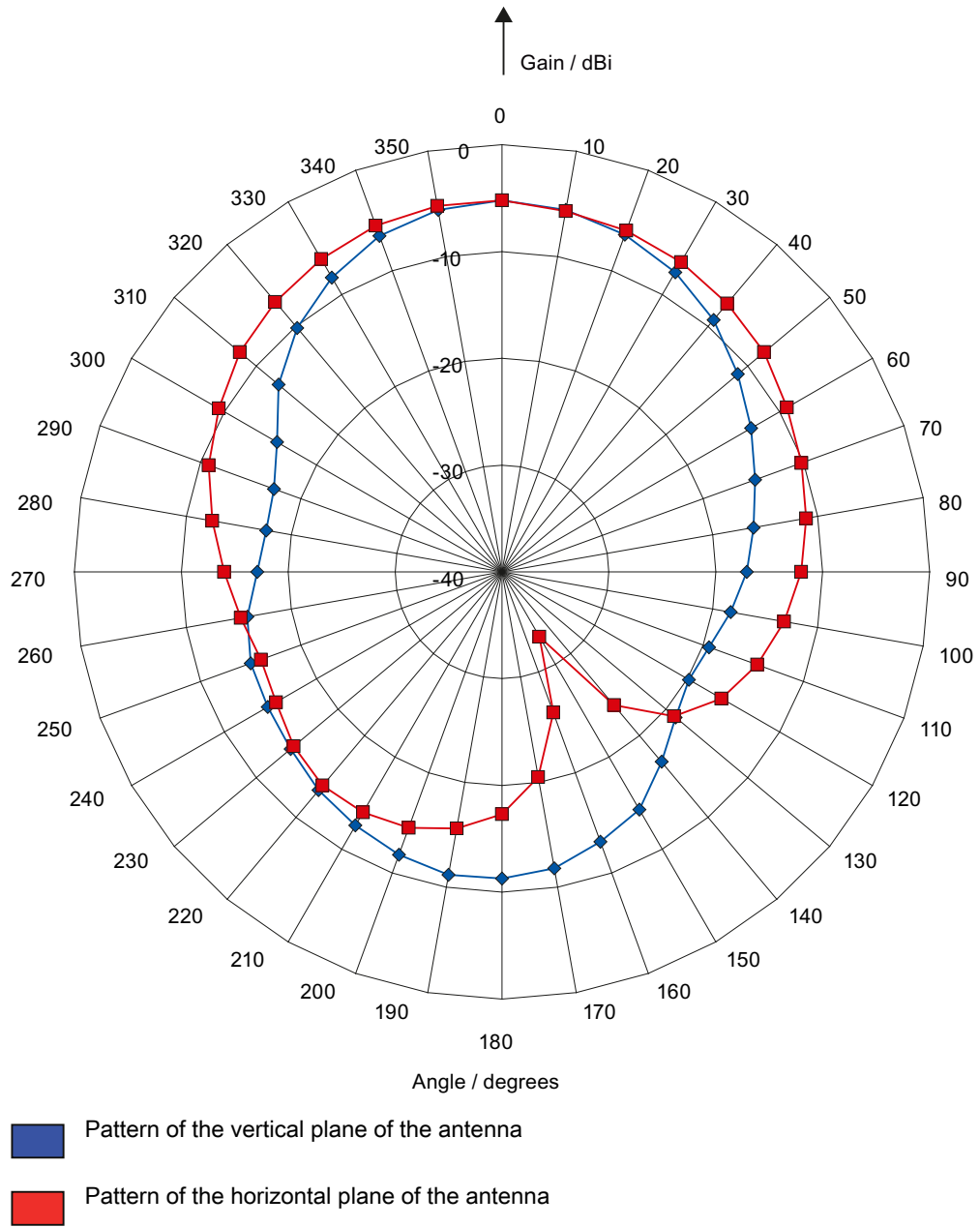

Figure 6-6 Directional radiation pattern RF620A ETSI on metallic mounting surface

Directional radiation pattern ETSI on non-metallic mounting surface

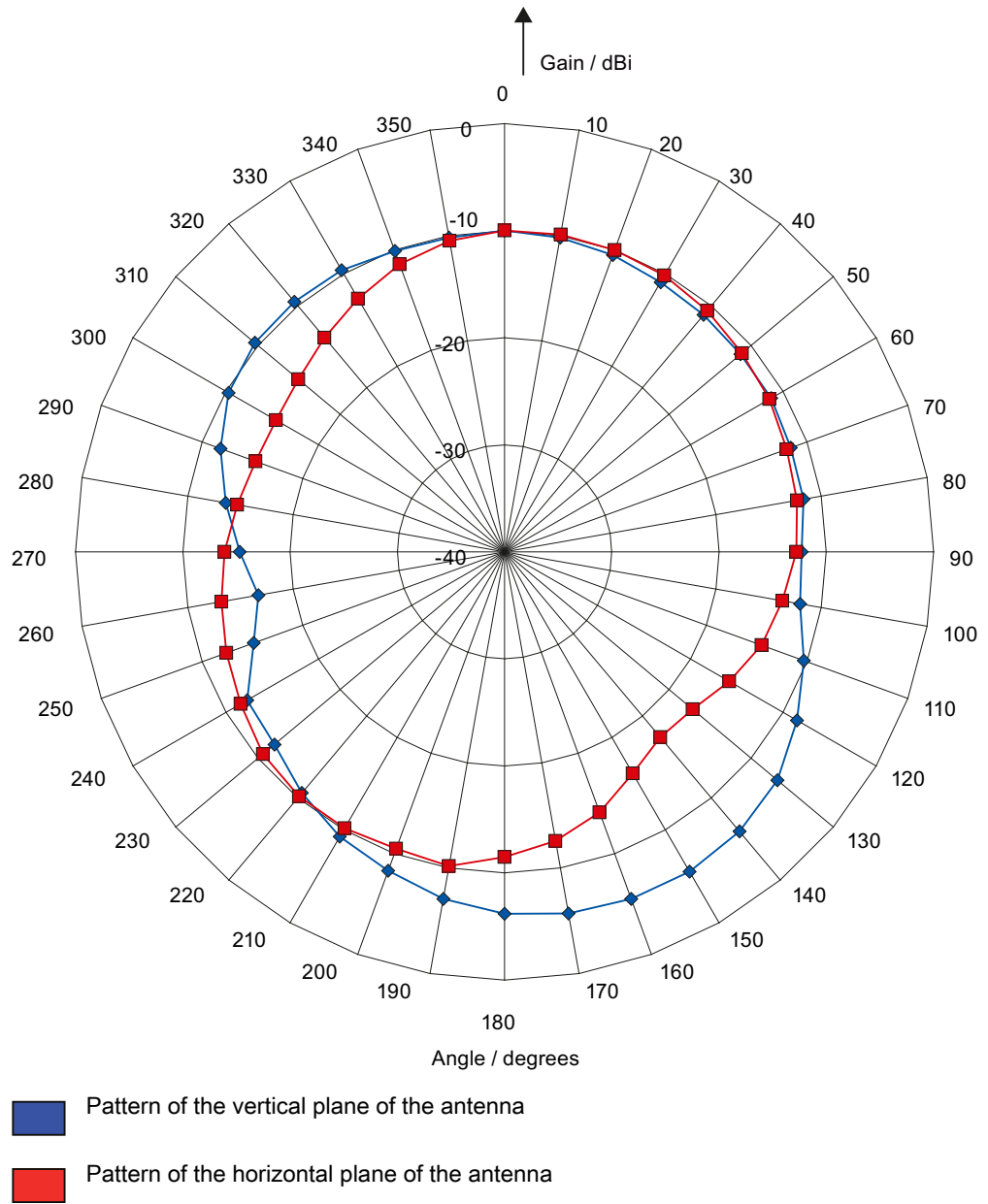

Figure 6-7 Directional radiation pattern RF620A ETSI on non-metallic mounting surface

6.2.8.2 Antenna pattern FCC

Directional radiation pattern USA (FCC)

The directional radiation pattern is shown for nominal alignment and a center frequency of 915 MHz.

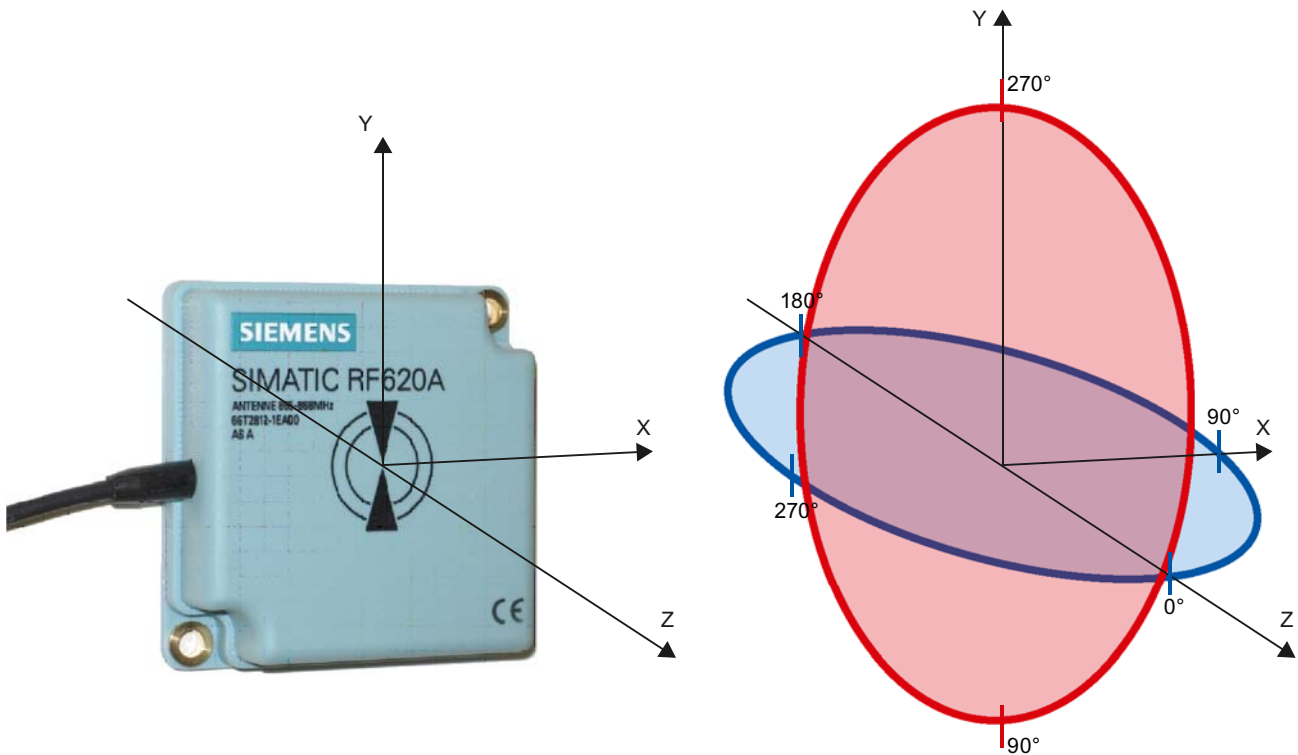

Figure 6-8 Reference system

The half-power beamwidth of the antenna is defined by the angle between the two -3 dB points (corresponding to half the power referred to the maximum power). Which range (in %) corresponds to the dB values in the patterns can be obtained from this table .

Note that the measurements presented graphically below were carried out in a low-reflection environment. Low deviations can therefore occur in a normally reflecting environment.

Directional radiation pattern of the RF620A (FCC) on metallic mounting surface (15 cm x 15 cm)

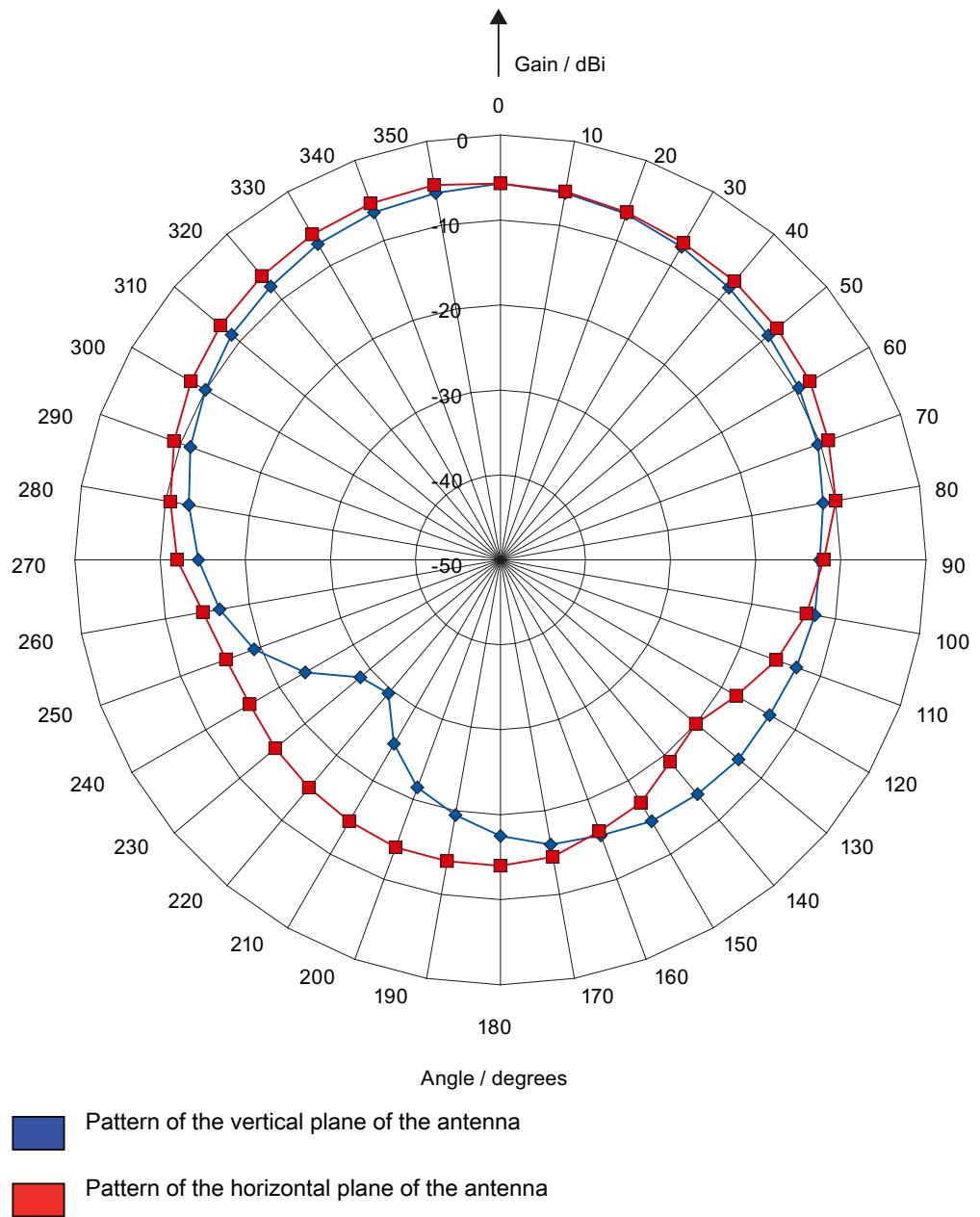

Figure 6-9 Directional radiation pattern of the RF620A (FCC) on metallic mounting surface

Directional radiation pattern of the RF620A (FCC) on non-metallic mounting surface

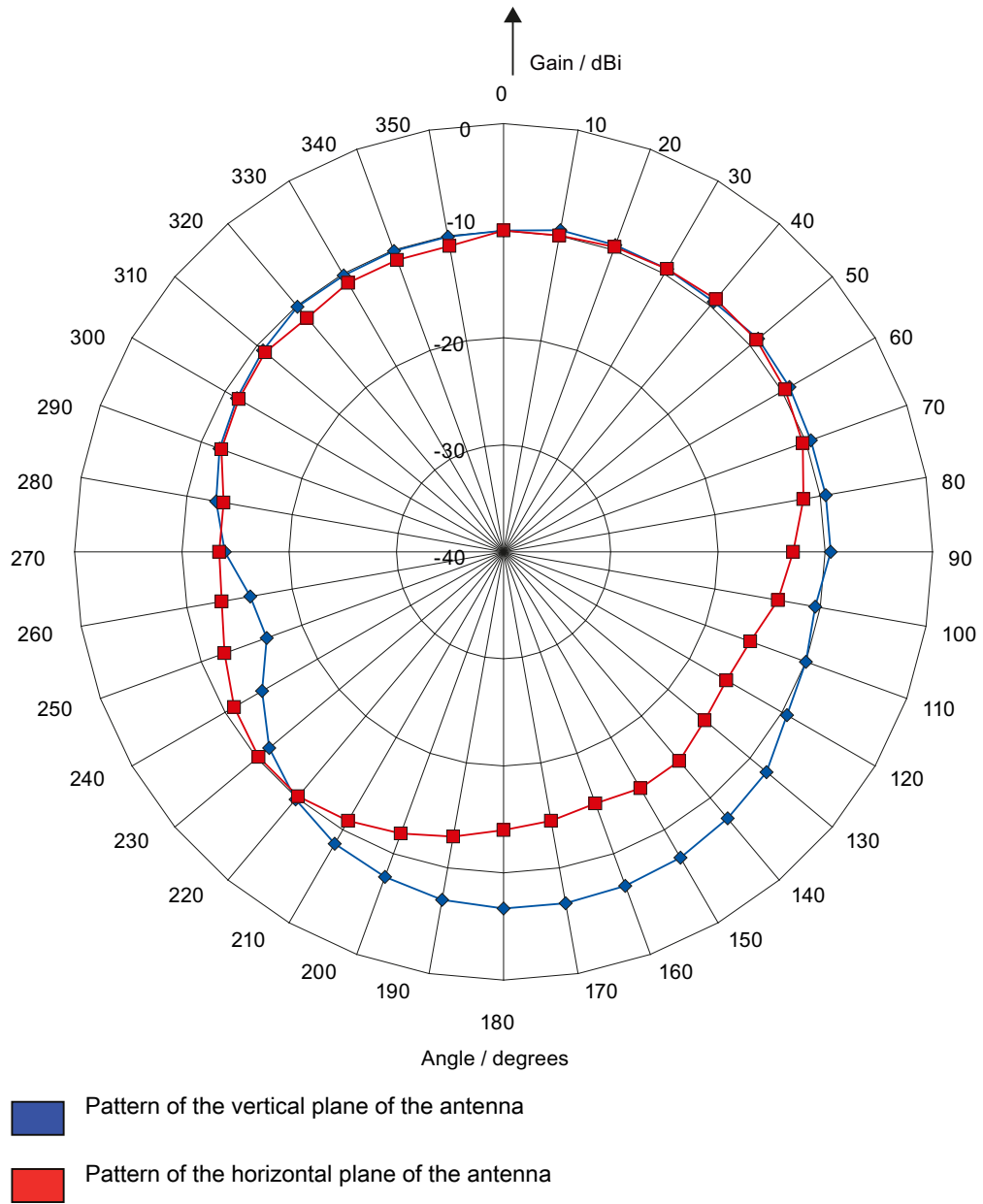

Figure 6-10 Directional radiation pattern of the RF620A (FCC) on non-metallic mounting surface

6.2.8.3 Interpretation of directional radiation patterns

The following overview table will help you with the interpretation of directional radiation patterns.

The table shows which dBi values correspond to which read/write ranges (in %): You can read the radiated power depending on the reference angle from the directional radiation patterns, and thus obtain information on the read/write range with this reference angle with regard to a transponder.

The dBr values correspond to the difference between the maximum dBi value and a second dBi value.

Deviation from maximum antenna gain [dBr]	Read/write range [%]
0	100
-3	70
-6	50
-9	35
-12	25
-15	18
-18	13

Example

As one can see from the Auto-Hotspot, the maximum antenna gain is -5 dBi. In the vertical plane, the antenna gain has dropped to approx. -11 dBi at +40° and 320°. Therefore the dBr value is -6. The antenna range is only 50% of the maximum range at ± 40° from the Z axis within the vertical plane (see values shown in blue in the directional radiation pattern: characteristic of the vertical plane of the antenna and the associated representation of the reference system).

6.2.9 Read/write ranges

The following tables show the typical read/write ranges of RF600 readers which are connected to the RF620A antenna via the 3 m antenna cable (1 dB loss) and various types of tags.

Note

Tolerances

Please note that tolerances of ±20% are admissible due to production and temperature conditions.

When using other antenna cables, the ranges listed here are reduced as a result of the higher antenna cable losses in the following manner:

Cable designation	Order No.	Length [m]	Cable loss [dB]	Read/write range [%]
Antenna cable	6GT2815-0BH30	3	1	100
Antenna cable, suitable for drag chains	6GT2815-2BH50	5	1,25	98
Antenna cable	6GT2815-1BN10	10	2	90
Antenna cable	6GT2815-0BN10	10	4	70
Antenna cable, suitable for drag chains	6GT2815-2BN15	15	4	70
Antenna cable	6GT2815-0BN20	20	4	70

The measuring tolerances in the following tables are ± 3 cm.

Reading ranges RF620R/RF630R

Table 6- 3 Reading ranges RF620R/RF630R

Transponder	Connection to RF620R/RF630R			
	RF620A ETSI on metal [cm]	RF620A ETSI on non-metal [cm]	RF620A FCC on metal [cm]	RF620A FCC on non-metal [cm]
RF630L (6GT2810-2AB00, -2AB01, -2AB02-0AX0)	90 ¹⁾	70 ¹⁾	60 ¹⁾	50 ¹⁾
RF630L (6GT2810-2AB03)	55	50	55	45
RF680L	55	50	55	45
RF610T	55	50	55	45
RF620T	55	45	70	60
RF625T	30 ²⁾	25 ²⁾	45 ²⁾	30 ²⁾
RF630T	25 ²⁾	20 ²⁾	35 ²⁾	25 ²⁾
RF640T Gen 2	55 ²⁾	45 ²⁾	40 ²⁾	35 ²⁾
RF680T	60	50	90	70

¹⁾ Transponder mounted on cardboard

²⁾ Transponder mounted on metal

Writing ranges RF620R/RF630R

Table 6- 4 Writing ranges RF620R/RF630R

Transponder	Connection to RF620R/RF630R			
	RF620A ETSI on metal [cm]	RF620A ETSI on non-metal [cm]	RF620A FCC on metal [cm]	RF620A FCC on non-metal [cm]
RF630L (6GT2810-2AB00, -2AB01, -2AB02- 0AX0)	45 ¹⁾	40 ¹⁾	35 ¹⁾	30 ¹⁾
RF630L (6GT2810-2AB03)	35	30	20	25
RF680L	35	30	20	25
RF610T	35	30	20	25
RF620T	30	30	40	35
RF625T	20 ²⁾	5 ²⁾	20 ²⁾	10 ²⁾
RF630T	15 ²⁾	5 ²⁾	15 ²⁾	10 ²⁾
RF640T Gen 2	35 ²⁾	20 ²⁾	20 ²⁾	15 ²⁾
RF680T	40	30	40	35

¹⁾ Transponder mounted on cardboard

²⁾ Transponder mounted on metal

Reading ranges RF640R/RF670R

Table 6- 5 Reading ranges RF640R/RF670R

Transponder	Connection to RF640R/RF670R			
	RF620A ETSI on metal [cm]	RF620A ETSI on non-metal [cm]	RF620A FCC on metal [cm]	RF620A on non-metal [cm]
RF630L (6GT2810-2AB00, -2AB01, -2AB02- 0AX0)	135 ¹⁾	120 ¹⁾	100 ¹⁾	90 ¹⁾
RF630L (6GT2810-2AB03)	85	70	75	65
RF680L	85	70	75	65
RF610T	85	70	75	65
RF620T	85	85	95	95
RF625T	50 ²⁾	45 ²⁾	60 ²⁾	45 ²⁾
RF630T	40 ²⁾	35 ²⁾	50 ²⁾	35 ²⁾
RF640T	40 ²⁾	35 ²⁾	40 ²⁾	30 ²⁾

Transponder	Connection to RF640R/RF670R			
	RF620A ETSI on metal [cm]	RF620A ETSI on non-metal [cm]	RF620A FCC on metal [cm]	RF620A on non-metal [cm]
RF640T Gen 2	90 ²⁾	70 ²⁾	70 ²⁾	50 ²⁾
RF680T	90	90	135	95

1) Transponder mounted on cardboard

2) Transponder mounted on metal

Writing ranges RF640R/RF670R

Table 6- 6 Writing ranges RF640R/RF670R

Transponder	Connection to RF640R/RF670R			
	RF620A ETSI on metal	RF620A ETSI on non-metal	RF620A FCC on metal	RF620A on non-metal
RF630L (6GT2810-2AB00, -2AB01, -2AB02- 0AX0)	110 ¹⁾	90 ¹⁾	55 ¹⁾	50 ¹⁾
RF630L (6GT2810-2AB03)	75	70	60	55
RF680L	75	70	60	55
RF610T	75	70	60	55
RF620T	60	55	60	45
RF625T	40 ²⁾	30 ²⁾	45 ²⁾	30 ²⁾
RF630T	30 ²⁾	25 ²⁾	35 ²⁾	25 ²⁾
RF640T	35 ²⁾	30 ²⁾	25 ²⁾	25 ²⁾
RF640T Gen 2	70 ²⁾	60 ²⁾	50 ²⁾	40 ²⁾
RF680T	80	75	100	80

1) Transponder mounted on cardboard

2) Transponder mounted on metal

6.2.10 Technical data

Table 6- 7 General technical specifications RF620A

Feature	SIMATIC RF620A ETSI	SIMATIC RF620A FCC
Dimensions (L x W x H)	75 x 75 x 20 mm	
Color	Pastel turquoise	
Material	PA 12 (polyamide 12)	
	Silicone-free	
Frequency range	865 to 868 MHz	902 to 928 MHz
Plug connection	30 cm coaxial cable with RTNC coupling (for connection of antenna cable)	
Max. radiated power	< 500 mW ERP	No limitation (because antenna gain < 6 dBi)
Max. power	2 W	1 W
Impedance	50 ohms	
Antenna gain	-10 dBi ... -5 dBi	
	Depends on background, see Chapter Directional radiation pattern ETSI	Depends on background, see Chapter Directional radiation pattern FCC
VSWR (standing wave ratio)	Max. 2:1	
Polarization	Linear	
Beam angle for sending/receiving	<ul style="list-style-type: none"> • When mounted on a metal surface of 15 cm x 15 cm ¹⁾ • Horizontal plane: 100° • Vertical plane: 75° See Chapter Auto-Hotspot 	<ul style="list-style-type: none"> • Horizontal plane: 130° • Vertical plane: 105° See section Directional characteristics for FCC
Shock resistant to EN 60068-2-27	50 g	
Vibration resistant to EN 60068-2-6	20 g	
Attachment of the antenna	2 x M5 screws	
Tightening torque (at room temperature)	≤ 2 Nm	
Ambient temperature	<ul style="list-style-type: none"> • Operation • Transport and storage 	
	<ul style="list-style-type: none"> • -20 °C to +70 °C • -40 °C to +85 °C 	
MTBF in years		
Degree of protection according to EN 60529	IP67	
Weight, approx.	90 g	

¹⁾ The values differ for different dimensions/materials of the mounting surface.

6.2.11 Dimension drawing

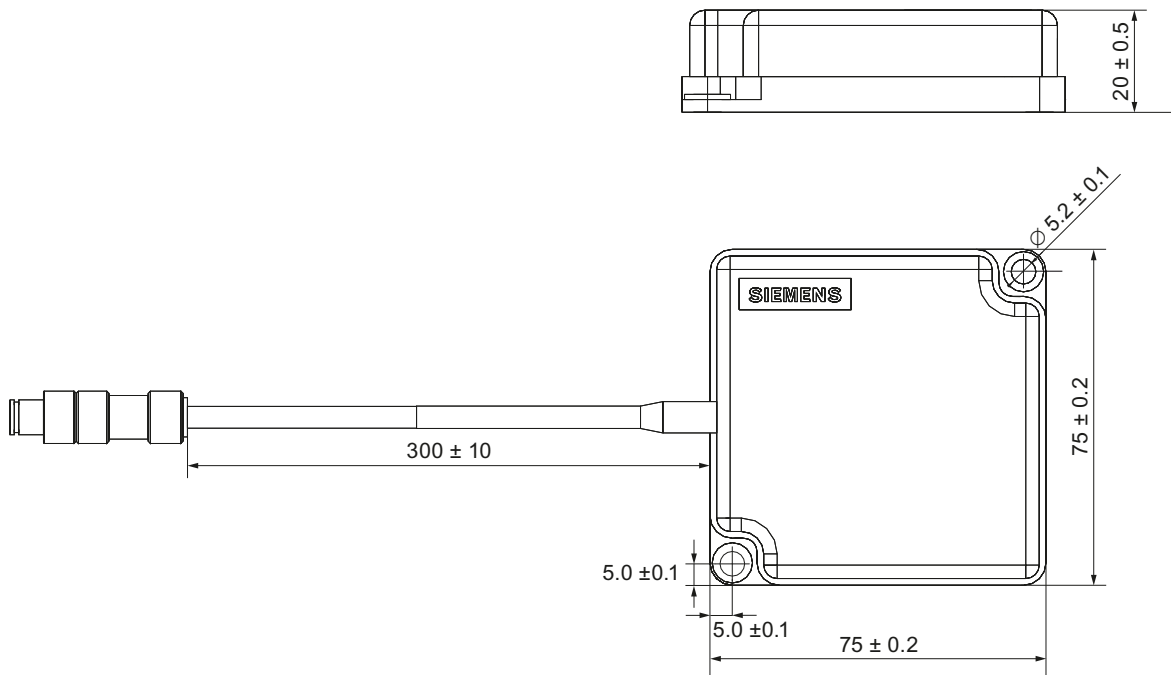

Figure 6-11 Dimension drawing RF620A

All dimensions in mm

6.2.12 Approvals & certificates

Table 6- 8 6GT2812-1EA00





Certificate	Designation
	Conformity in accordance with R&TTE directive in association with the readers and accessories used

Table 6- 9 6GT2812-1EA01

Standard	
 Federal Communications Commission	FCC CFR 47, Part 15 sections 15.247 Radio Frequency Interference Statement This equipment has been tested and found to comply with the limits for a Class B digital device, pursuant to Part 15 of the FCC Rules. The FCC approval is granted in association with the FCC approval of the following RF600 readers: <ul style="list-style-type: none"> FCC ID: NXW-RF600R (for RF620R: 6GT2811-5BA00-1AA1, RF630R: 6GT2811-4AA00-1AA1, RF640R: 6GT2811-3BA00-1AA0, RF670R as of FS C1: 6GT2811-0AB00-1AA0) FCC ID: NXW-RF630R (for 6GT2811-4AA00-1AA0) FCC ID: NXW-RF670 (for RF670R as of FS A1: 6GT2811-0AB00-1AA0)
Industry Canada Radio Standards Specifications	RSS-210 Issue 7, June 2007, Sections 2.2, A8 The approval for Industry Canada is granted in association with the Industry Canada approval of the following RF600 readers: <ul style="list-style-type: none"> IC: 267X-RF630 (for 6GT2811-4AA00-1AA0) IC: 267X-RF670, RF670R FS A1 (for 6GT2811-0AB00-1AA0) IC: 267X-RF600R, Model RF620R-2 (for 6GT2811-5BA00-1AA1) IC: 267X-RF600R, Model RF630R-2 (for 6GT2811-4AA00-1AA1) IC: 267X-RF600R, Model RF640R (for 6GT2811-3BA00-1AA0) IC: 267X-RF600R, model RF670R-2 as of FS C1 (for 6GT2811-0AB00-1AA0)
	This product is UL-certified for the USA and Canada. It meets the following safety standard(s): UL 60950-1 - Information Technology Equipment Safety - Part 1: General Requirements CSA C22.2 No. 60950 -1 - Safety of Information Technology Equipment UL Report E 205089

6.3 Antenna RF640A

6.3.1 Description

SIMATIC RF640A	Features	
	Field of application	The SIMATIC RF640A is a universal UHF antenna of compact, industry-standard design with medium range.
	Frequency range	865 to 928 MHz
	Polarization	RH circular Suitable for RF600 transponders that can pass in parallel with the antenna regardless of their orientation.
	Writing/reading range	max. 4.0 m
	Mounting	4 x M4 (VESA 100 fixing system)
	Connector	30 cm connecting cable (connected permanently to the antenna) and RTNC coupling An antenna cable is required for connection to the reader, e.g. 6GT2815-0BH30)
	Readers that can be connected	All RF600 readers with external antenna connectors
	Dimensions in mm	185 x 185 x 45
	Degree of protection	IP67

Frequency ranges

The antenna is available for broadband. It can therefore be used for two different frequency ranges that have been specified for the regions of Europe and China/USA respectively.

- The antenna for Europe (EU, EFTA countries) operates in the frequency range from 865 to 868 MHz.
- The antenna for China, the USA, and Canada operates in the frequency range from 902 to 928 MHz.

Function

The SIMATIC RF640A is used for transmitting and receiving RFID signals in the UHF frequency range. The antennas are connected to the SIMATIC RF600 readers via antenna cables that are available in different lengths.

6.3.2 Ordering data

Table 6- 10 Ordering data RF640A

Product	Order no.
SIMATIC RF640A	6GT2812-0GA08

Accessories

Table 6- 11 Ordering data (accessories)

Product	Order no.	
Connecting cable between reader and antenna	3 m (cable loss 1.0 dB)	6GT2815-0BH30
	5 m, suitable for drag chains (cable loss 1.25 dB)	6GT2815-2BH50
	10 m (cable loss 2.0 dB)	6GT2815-1BN10
	10 m (cable loss 4.0 dB)	6GT2815-0BN10
	15 m, suitable for drag chains (cable loss 4.0 dB)	6GT2815-2BN15
	20 m (cable loss 4.0 dB)	6GT2815-0BN20
Antenna mounting kit	See "RF600 System Manual", Chapter "Antennas" > "Mounting types"	6GT2890-0AA00

6.3.3 Installation and assembly

6.3.3.1 RF640A mounting types

VESA 100 mounting system

A standardized VESA 100 mounting system is provided to mount the antenna. The mounting system consists of four fixing holes for M4 screws at intervals of 100 mm.

This is therefore suitable for:

- Mounting on metallic and non-metallic backgrounds

Note

To achieve optimum wave propagation, the antenna should not be surrounded by conducting objects. The area between antenna and transponder should also allow wave propagation without interference.

Antenna Mounting Kit

The Antenna Mounting Kit allows the fine adjustment of the antenna field by setting the solid angle (see "RF600 System Manual", chapter "Antennas" > "Mounting types").

6.3.3.2 RF640A mounting types

VESA 100 mounting system

A standardized VESA 100 mounting system is provided to mount the antenna. The mounting system consists of four fixing holes for M4 screws at intervals of 100 mm.

This is therefore suitable for:

- Mounting on metallic and non-metallic backgrounds

Note

To achieve optimum wave propagation, the antenna should not be surrounded by conducting objects. The area between antenna and transponder should also allow wave propagation without interference.

Antenna Mounting Kit

The Antenna Mounting Kit allows the fine adjustment of the antenna field by setting the solid angle (see "RF600 System Manual", chapter "Antennas" > "Mounting types").

6.3.4 Connecting an antenna to the reader

The SIMATIC RF640A antenna must be connected to the reader using an antenna cable.

Preassembled standard cables in lengths of 3 m, 10 m, and 20 m are available for the connection.

The range of the antenna is limited by the cable loss. The maximum range can be achieved with the cable 6GT2815-0BH30 (length 3 m), since this has the lowest cable loss.

Requirement

Note

Use of Siemens antenna cable

To ensure optimum functioning of the antenna, it is recommended that a Siemens antenna cable be used in accordance with the list of accessories.

Strain relief

The antenna cable is provided with strain relief as shown in the following diagram:

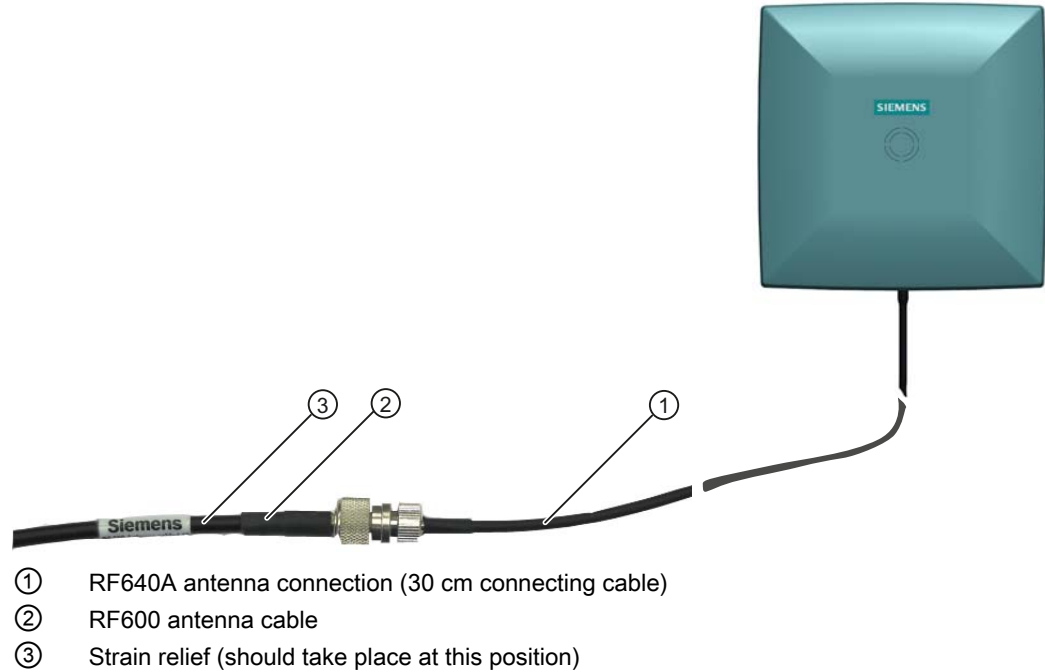

Figure 6-12 Strain relief

6.3.4.1 Bending radii and bending cycles of the cable

Cable designation	Order No.	Length [m]	Cable loss [dB]	Bending radius [mm]	Bending cycle
RF640A antenna connection	Fixed connection to antenna	0.3	-	15	1 Mal
Antenna cable	6GT2815-0BH30	3	1	51	1 Mal
Antenna cable (suitable for drag chains)	6GT2815-2BH50	5	1,25	48	1)
Antenna cable	6GT2815-1BN10	10	2	77	1 Mal
Antenna cable	6GT2815-0BN10	10	4	51	1 Mal

Cable designation	Order No.	Length [m]	Cable loss [dB]	Bending radius [mm]	Bending cycle
Antenna cable (suitable for drag chains)	6GT2815-0BN20	15	4	24	1)
Antenna cable	6GT2815-0BN20	20	4	77	1 Mal

1) With cables suitable for drag chains, 3 million bending cycles at a bending radius of 6.5 m and bending through ± 180 ° are permitted.

6.3.5 Parameter settings of RF640A for RF620R/RF630R

Operation within the EU, EFTA, or Turkey according to EN 302 208 V1.3.1

NOTICE
Limitation of the radiated power according to EN 302 208 V1.3.1
RF600 systems that are put into operation within the EU, EFTA, or Turkey (ETSI) can be operated with an RF640A antenna with a maximum radiated power of up to 2000 mW ERP (or 33 dBm ERP, 3250 mW EIRP, 35 dBm EIRP).

By adjusting the transmit power of up to 500 mW ERP (or 27 dBm ERP, 800 mW EIRP, 29.15 dBm EIRP) and taking into account the RF640A antenna gain of 4 dBi (6 dBic) and the cable loss associated with the antenna cable (see table), the radiated power of the antenna cannot be exceeded. You can make the power settings using the "distance_limiting" parameter. You will find more detailed information on the parameters in the section Parameter assignment manual RF620R/RF630R (<http://support.automation.siemens.com/WW/view/en/33287195>).

Operation in China

The national approval for RF600 systems in China requires a cap of 2000 mW ERP (or 33 dBm ERP, 3250 mW EIRP, 35 dBm EIRP). The possible combination of antenna gain, cable loss, and max. 500 mW radiated power of the RF630R reader means it is not possible to exceed 2000 mW ERP (or 33 dBm ERP, 3250 mW EIRP, 35 dBm EIRP).

Operation in the USA, Canada

NOTICE
<p>Limitation of the radiated power to 4000 mW EIRP (36 dBm EIRP)</p> <p>So that the FCC and IC-FCB requirements are met, the radiated power may not exceed 4000 mW EIRP (36 dBm EIRP). Therefore the system must satisfy the following relation:</p> <ul style="list-style-type: none"> • Conducted power P dBm of the RF600 reader (< 30 dBm) • Antenna gain G_i dBi in the FCC frequency band (≤ 4.3 dBi) • Cable loss a_k dB (≥ 1 dB) $P(\text{dBm}) \leq 30 \text{ dBm} - (G_i - 6 \text{ dBi}) + a_k$

6.3.6 Parameter settings of RF640A for RF640R/RF670R

Operation within the EU, EFTA, or Turkey

NOTICE
<p>Limitation of the radiated power according to EN 302 208 V1.3.1</p> <p>RF600 systems that are put into operation within the EU, EFTA, or Turkey (ETSI) can be operated with an RF640A antenna with a maximum radiated power of 2000 mW ERP (or 33 dBm ERP, 3250 mW EIRP, 35 dBm EIRP).</p>

By adjusting the radiated power of up to 1300 mW ERP (or 31.15 dBm ERP, 2140 mW EIRP, 33.3 dBm EIRP), the RF640A antenna gain of 4 dBi (7 dBic) and the cable loss associated with the antenna cable (see table), the radiated power of the reader is correctly configured and the radiated power at the antenna is thus not exceeded.

Operation in China

By setting a max. radiated power of 1300 mW ERP (or 31.15 dBm ERP, 2140 mW EIRP, 33.3 dBm EIRP), the RF640A antenna gain of 4.3 dBi (7.3 dBic) and the cable loss associated with the antenna cable (see table), the radiated power of the reader is correctly configured.

Operation in the USA, Canada

NOTICE
Limitation of the radiated power to 4000 mW EIRP (36 dBm EIRP) So that the FCC and IC requirements are met, the radiated power may not exceed 4000 mW EIRP (36 dBm EIRP). Therefore the system must satisfy the following relation: <ul style="list-style-type: none">• Conducted power P dBm of the RF600 reader (< 30 dBm)• Antenna gain G_i dBi in the FCC frequency band (≤ 4.3 dBi)• Cable loss a_k dB (≥ 1 dB) $P(\text{dBm}) \leq 30 \text{ dBm} - (G_i - 6 \text{ dBi}) + a_k$

6.3.7 Antenna patterns

6.3.7.1 Antenna radiation patterns in the ETSI frequency band

Directional radiation pattern Europe (ETSI)

The directional radiation pattern is shown for nominal alignment and a center frequency of 866.3 MHz. The nominal antenna alignment is given when the antenna elevation is provided as shown in the following figure.

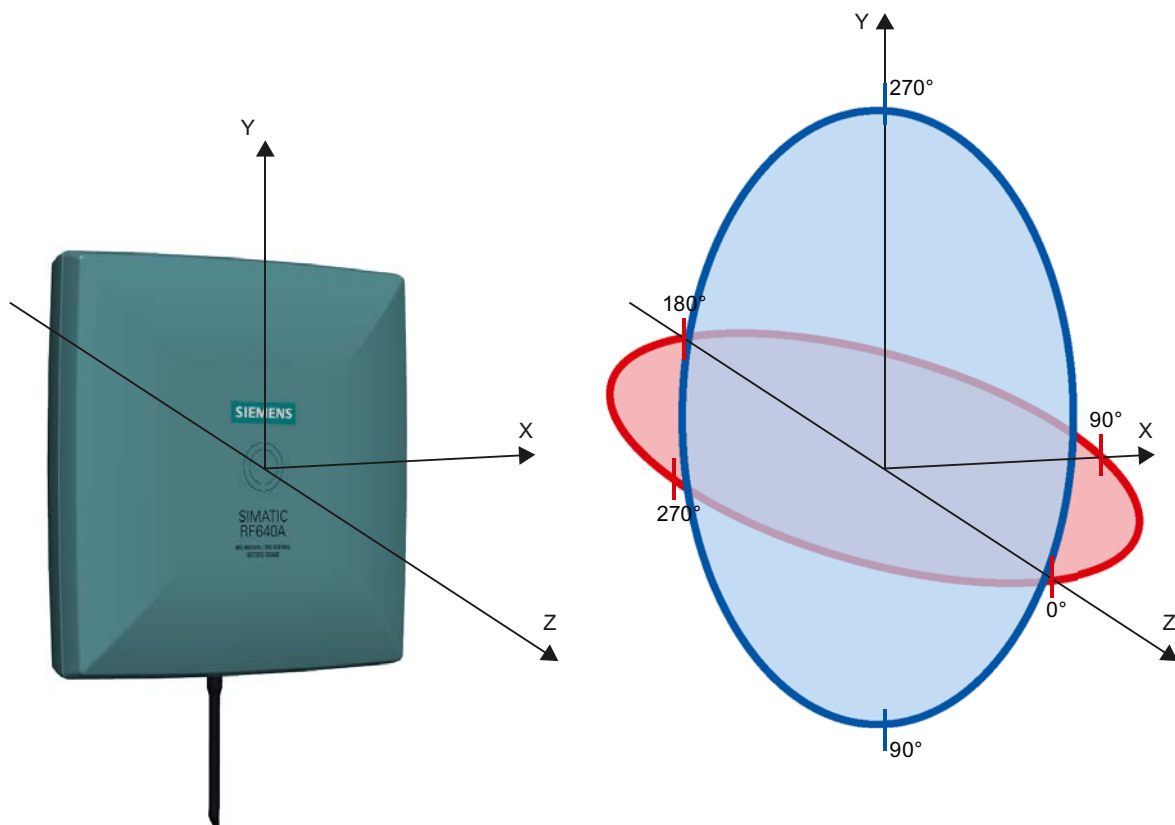

Figure 6-13 Reference system

The half-power beam width of the antenna is defined by the angle between the two -3 dB points. Which range (in %) corresponds to the dB values in the patterns can be obtained from this table (Page 226).

Note that the measurements presented graphically below were carried out in a low-reflection environment. Deviations can therefore occur in a normally reflecting environment.

Directional radiation patterns in the ETSI frequency band

Polarization axis and axis of symmetry are parallel

In a configuration based on the following directional radiation pattern of the antenna, the axis of symmetry of the antenna and the polarization axis of the transponder are parallel.

