

RFID Systems
SIMATIC RF300

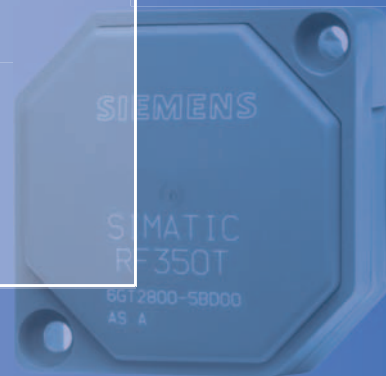

simatic sensors

SIEMENS

SIEMENS

SIMATIC Sensors



RFID systems SIMATIC RF300

System Manual

<u>Introduction</u>	1
<u>Safety information</u>	2
<u>System overview</u>	3
<u>RF300 system planning</u>	4
<u>Readers</u>	5
<u>Transponders</u>	6
<u>Communication modules</u>	7
<u>System diagnostics</u>	8
<u>Accessories</u>	9
<u>Appendix</u>	A

Safety Guidelines

This manual contains notices you have to observe in order to ensure your personal safety, as well as to prevent damage to property. The notices referring to your personal safety are highlighted in the manual by a safety alert symbol, notices referring only to property damage have no safety alert symbol. These notices shown below are graded according to the degree of danger.

 DANGER
indicates that death or severe personal injury will result if proper precautions are not taken.
 WARNING
indicates that death or severe personal injury may result if proper precautions are not taken.
 CAUTION
with a safety alert symbol, indicates that minor personal injury can result if proper precautions are not taken.
CAUTION
without a safety alert symbol, indicates that property damage can result if proper precautions are not taken.
NOTICE
indicates that an unintended result or situation can occur if the corresponding information is not taken into account.

If more than one degree of danger is present, the warning notice representing the highest degree of danger will be used. A notice warning of injury to persons with a safety alert symbol may also include a warning relating to property damage.

Qualified Personnel

The device/system may only be set up and used in conjunction with this documentation. Commissioning and operation of a device/system may only be performed by **qualified personnel**. Within the context of the safety notes in this documentation qualified persons are defined as persons who are authorized to commission, ground and label devices, systems and circuits in accordance with established safety practices and standards.

Prescribed Usage

Note the following:

 WARNING
This device may only be used for the applications described in the catalog or the technical description and only in connection with devices or components from other manufacturers which have been approved or recommended by Siemens. Correct, reliable operation of the product requires proper transport, storage, positioning and assembly as well as careful operation and maintenance.

Trademarks

All names identified by ® are registered trademarks of the Siemens AG. The remaining trademarks in this publication may be trademarks whose use by third parties for their own purposes could violate the rights of the owner.

Disclaimer of Liability

We have reviewed the contents of this publication to ensure consistency with the hardware and software described. Since variance cannot be precluded entirely, we cannot guarantee full consistency. However, the information in this publication is reviewed regularly and any necessary corrections are included in subsequent editions.

Table of contents

1	Introduction	11
1.1	Navigating in the system manual.....	11
1.2	Preface.....	12
2	Safety information	13
3	System overview	15
3.1	RFID systems.....	15
3.2	RF300.....	16
3.2.1	RF300 system overview.....	16
3.2.2	Application areas of RF300.....	17
3.2.3	RFID components and their function.....	18
3.2.4	Technical data.....	19
4	RF300 system planning	21
4.1	Fundamentals of application planning.....	21
4.1.1	Selection criteria for SIMATIC RF300 components.....	21
4.1.2	Transmission window and read/write distance.....	22
4.1.3	Width of the transmission window.....	26
4.1.4	Impact of secondary fields.....	26
4.1.5	Permissible directions of motion of the transponder.....	27
4.1.6	Operation in static and dynamic mode.....	28
4.1.7	Dwell time of the transponder.....	29
4.1.8	Communication between communication module, reader (with IQ-Sense interface) and transponder.....	30
4.1.9	Calculation example (IQ-Sense).....	31
4.1.10	Communication between communication module, reader (with RS422 interface) and transponder.....	33
4.1.11	Calculation example (RS422).....	35
4.2	Field data for transponders, readers and antennas.....	37
4.3	Relationship between the volume of data and the transponder speed.....	41
4.3.1	RF310R with IQ-Sense.....	41
4.3.2	RF310R with RS422.....	42
4.3.3	RF340R and RF350R.....	44
4.3.4	RF380R.....	49
4.4	Installation guidelines.....	54
4.4.1	Overview.....	54
4.4.2	Reduction of interference due to metal.....	55
4.4.3	Effects of metal on different transponders and readers.....	58
4.4.4	Impact on the transmission window by metal.....	58
4.5	Chemical resistance of the transponders.....	65

4.6	EMC Directives	72
4.6.1	Overview	72
4.6.2	What does EMC mean?	73
4.6.3	Basic rules	74
4.6.4	Propagation of electromagnetic interference	76
4.6.5	Cabinet configuration	79
4.6.6	Prevention of interference sources	82
4.6.7	Equipotential bonding	83
4.6.8	Cable shielding	84
5	Readers	87
5.1	Overview	87
5.2	RF310R with IQ-Sense interface	88
5.2.1	Features	88
5.2.2	Pin assignment of RF310R IQ-Sense interface	88
5.2.3	Display elements of the RF310R reader with IQ-Sense interface	88
5.2.4	Ensuring reliable data exchange	89
5.2.5	Metal-free area	89
5.2.6	Minimum distance between RF310R readers	89
5.2.7	Technical data for RF310R reader with IQ-Sense interface	90
5.2.8	FCC information	91
5.2.9	Ordering data of RF310R with IQ-Sense interface	91
5.2.10	Dimension drawing	92
5.3	RF310R with RS422 interface	93
5.3.1	Features	93
5.3.2	Pin assignment of RF310R RS422 interface	93
5.3.3	Display elements of the RF310R reader with RS422 interface	94
5.3.4	Ensuring reliable data exchange	94
5.3.5	Metal-free area	94
5.3.6	Minimum distance between RF310R readers	95
5.3.7	Technical specifications of the RF310R reader with RS422 interface	96
5.3.8	FCC information	97
5.3.9	Ordering data for RF310R with RS422 interface	97
5.3.10	Dimension drawing	98
5.4	RF340R	99
5.4.1	Features	99
5.4.2	Pin assignment of RF340R RS422 interface	99
5.4.3	Display elements of the RF340R reader	100
5.4.4	Ensuring reliable data exchange	100
5.4.5	Metal-free area	100
5.4.6	Minimum distance between RF340R readers	101
5.4.7	Technical data of the RF340R reader	102
5.4.8	FCC information	103
5.4.9	Ordering data for RF340R	103
5.4.10	Dimension drawing	104

5.5	RF350R.....	105
5.5.1	Features.....	105
5.5.2	Pin assignment of RF350R RS422 interface.....	105
5.5.3	Display elements of the RF350R reader.....	106
5.5.4	Ensuring reliable data exchange.....	106
5.5.5	Metal-free area.....	106
5.5.6	Technical data of the RF350R reader.....	107
5.5.7	FCC information.....	108
5.5.8	Ordering data for RF350R.....	108
5.5.9	Dimension drawing.....	109
5.5.10	Antennas.....	110
5.5.10.1	Features.....	110
5.5.10.2	Ensuring reliable data exchange.....	112
5.5.10.3	Metal-free area.....	112
5.5.10.4	Minimum distance between antennas.....	114
5.5.10.5	Technical data for antennas.....	116
5.5.10.6	Ordering data for antennas.....	116
5.5.10.7	Dimension drawings for antennas.....	117
5.6	RF380R.....	118
5.6.1	Features.....	118
5.6.2	Pin assignment of RF380R RS232/RS422 interface.....	118
5.6.3	Display elements of the RF380R reader.....	119
5.6.4	Ensuring reliable data exchange.....	119
5.6.5	Metal-free area.....	119
5.6.6	Minimum distance between RF380R readers.....	120
5.6.7	Technical specifications of the RF380R reader.....	121
5.6.8	FCC information.....	122
5.6.9	RF380R ordering data.....	122
5.6.10	Dimension drawing.....	122
6	Transponders.....	123
6.1	Overview.....	123
6.2	RF320T.....	124
6.2.1	Features.....	124
6.2.2	Metal-free area.....	125
6.2.3	Technical data.....	126
6.2.4	Ordering data.....	126
6.2.5	Dimension drawing.....	127
6.3	RF340T.....	128
6.3.1	Features.....	128
6.3.2	Metal-free area.....	129
6.3.3	Technical specifications.....	130
6.3.4	Ordering data.....	130
6.3.5	Dimension drawing.....	131
6.4	RF350T.....	132
6.4.1	Features.....	132
6.4.2	Metal-free area.....	133
6.4.3	Technical data.....	134
6.4.4	Ordering data.....	134
6.4.5	Dimension drawing.....	135

6.5	RF360T	136
6.5.1	Features	136
6.5.2	Metal-free area	137
6.5.3	Technical data	139
6.5.4	Ordering data	139
6.5.5	Dimension drawing	140
6.6	RF370T	141
6.6.1	Features	141
6.6.2	Metal-free area	142
6.6.3	Mounting instructions	143
6.6.4	Technical specifications	144
6.6.4.1	Technical data for RF370T with 32 KB FRAM	144
6.6.4.2	Technical data for RF370T with 64 KB FRAM	145
6.6.5	Ordering data	146
6.6.6	Dimensional drawing	147
6.7	RF380T	148
6.7.1	Features	148
6.7.2	Installation guidelines for RF380T	149
6.7.2.1	Mounting instructions	149
6.7.2.2	Metal-free area	151
6.7.3	Configuring instructions	152
6.7.3.1	Temperature dependence of the transmission window	152
6.7.3.2	Temperature response in cyclic operation	154
6.7.4	Technical specifications	157
6.7.5	Ordering data	158
6.7.6	Dimensional drawing	158
6.8	Memory configuration of the RF300 tags	159
7	Communication modules	161
7.1	Overview	161
7.2	8xIQ-Sense	162
7.2.1	Features	162
7.2.2	Indicators	163
7.2.3	Configuration	164
7.2.4	Addressing	167
7.2.5	Technical data	169
7.2.6	Ordering data	169
7.3	ASM 452	170
7.3.1	Features	170
7.3.2	Pin assignment and display elements	171
7.3.3	Configuration	172
7.3.4	Technical data	176
7.3.5	PROFIBUS Diagnosis	177
7.3.6	Dimension drawing	178
7.3.7	Ordering data	179

7.4	ASM 456	180
7.4.1	Description	180
7.4.2	Setting the PROFIBUS address	184
7.4.3	Wiring up ASM 456	187
7.4.4	Diagnosis using LEDs	192
7.4.5	Technical data	194
7.4.6	Dimension drawing	195
7.4.7	Ordering data	196
7.5	ASM 473	197
7.5.1	Features	197
7.5.2	Pin assignment and display elements	198
7.5.3	Configuration	199
7.5.4	Technical data	202
7.5.5	Dimensional drawings	203
7.5.6	Ordering data	204
7.6	ASM 475	205
7.6.1	Features	205
7.6.2	Indicators	206
7.6.3	Configuration	208
7.6.4	Technical data	211
7.6.5	Ordering data	212
7.7	RF170C	213
7.7.1	Description	213
7.7.2	Connect the RF170C with the connection module	218
7.7.3	LED displays on the RF170C communication module	220
7.7.4	Technical specifications	222
7.7.5	Dimensional drawings	224
7.7.6	Ordering data	225
7.8	RF180C	226
7.8.1	Description	226
7.8.2	Connection	231
7.8.2.1	Wiring connection block M12, 7/8"	234
7.8.3	Parameter assignment	237
7.8.3.1	PROFINET IO configuration	237
7.8.3.2	Assigning device names to the I/O device	238
7.8.3.3	Configuration parameters of the RF180C	240
7.8.3.4	Input parameters for RF180C	241
7.8.3.5	Command table of the RF180C	242
7.8.4	PROFINET diagnostics	243
7.8.4.1	Diagnosis using LEDs	243
7.8.4.2	Parameterization of the diagnostics	246
7.8.4.3	Structure of the diagnostic data	248
7.8.5	Technical data	249
7.8.6	Dimension drawing for RF180C with fixing holes	251
7.8.7	Connecting cable to the reader/SLG	252
7.8.7.1	Routing of standard cables	252
7.8.7.2	Self-assembled cable	254

8	System diagnostics	255
8.1	Error codes.....	255
8.2	Diagnostics functions.....	256
8.2.1	Overview.....	256
8.2.2	Reader diagnostics with SLG STATUS.....	257
8.2.3	Transponder diagnostics with MDS STATUS.....	259
9	Accessories	261
9.1	RFID Systems Software & Documentation.....	261
A	Appendix	263
A.1	Certificates and Approvals.....	263
A.2	Service & Support.....	266
A.3	Contacts.....	266
A.4	Training.....	267
	Glossary	269
	Index	273

Introduction

1.1 Navigating in the system manual

Structure of contents	Contents
Table of contents	Organization of the documentation, including the index of pages and chapters
Introduction	Purpose, layout and description of the important topics.
Safety instructions	Refers to all the valid technical safety aspects which have to be adhered to while installing, commissioning and operating the product/system and with reference to statutory regulations.
System overview	Overview of all RF identification systems, system overview of SIMATIC RF300
RFID system planning	Information about possible applications of SIMATIC RF300, support for application planning, tools for finding suitable SIMATIC RF300 components.
Reader	Description of readers which can be used for SIMATIC RF300
Transponder	Description of transponders which can be used for SIMATIC RF300
Communication modules	Description of communication modules used for SIMATIC RF300
System diagnostics	Description of system diagnostics available for SIMATIC RF300
Accessories	Products available in addition to SIMATIC RF300
Appendix	Service and support, contact partners, training centers

1.2 Preface

Purpose of this document

This system manual contains all the information needed to plan and configure the system. It is intended both for programming and testing/debugging personnel who commission the system themselves and connect it with other units (automation systems, further programming devices), as well as for service and maintenance personnel who install expansions or carry out fault/error analyses.

Scope of validity of this document

This documentation is valid for all supplied variations of the SIMATIC RF300 system and describes the state of delivery as of September 2007.

Conventions

The following terms/abbreviations are used synonymously in this document:

- Reader, read/write device, write/read device
- Tag, transponder, mobile data memory, data carrier, MDS
- Communication module, interface module, ASM

History

Currently released versions of the SIMATIC RF300 system manual:

Edition	Remarks
09/2007	Revised edition, components added: RF380R and RF180C
07/2007	Revised edition, degrees of protection changed for the RF300 reader
12/2006	Revised edition, components added: RF370T, RF380T and RF170C
04/2006	Revised edition, components added: RF340R as well as RF350R with the antenna types ANT 1, ANT 18 and ANT 30
11/2005	Revised edition, components added: RF310R with RS422 interface, RF350T and RF360T; ASM 452, ASM 456, ASM 473 and ASM 475
05/2005	First Edition

Declaration of conformity

The EC declaration of conformity and the corresponding documentation are made available to authorities in accordance with the EC directives stated above. Your sales representative can provide these on request.

Observance of installation guidelines

The installation guidelines and safety instructions given in this documentation must be followed during commissioning and operation.

Safety information

 CAUTION
--

Please observe the safety instructions on the back cover of this documentation.

SIMATIC RFID products comply with the salient safety specifications to IEC, VDE, EN, UL and CSA. If you have questions about the validity of the installation in the planned environment, please contact your service representative.

CAUTION

Alterations to the devices are not permitted.

Failure to observe this requirement shall constitute a revocation of the radio equipment approval, CE approval and manufacturer's warranty.

Repairs

Repairs may only be carried out by authorized qualified personnel.

 WARNING
--

Unauthorized opening of and improper repairs to the device may result in substantial damage to equipment or risk of personal injury to the user.
--

System expansion

Only install system expansion devices designed for this device. If you install other upgrades, you may damage the system or violate the safety requirements and regulations for radio frequency interference suppression. Contact your technical support team or your sales outlet to find out which system upgrades are suitable for installation.

CAUTION

If you cause system defects by installing or exchanging system expansion devices, the warranty becomes void.
--

System overview

3.1 RFID systems

RFID systems from Siemens control and optimize material flow. They identify reliably, quickly and economically, are insensitive to contamination and store data directly on the product.

Identification system	Frequency	Range, max.	Memory, max.	Data transfer rate (typical) in byte/s	Temperature, max.	Special features
RF300	13.56 MHz	0.15 m	20 byte EEPROM, 64 KB FRAM	3750	Reader: -25 °C to +70 °C Transponder: -40 °C to +85 °C +220 °C cyclic	IQ-Sense interface available; integrated diagnostic functions; battery-free data memory
MOBY D	13.56 MHz	0,8 m	112 byte EEPROM	110	+ 85 °C or + 200 °C	SmartLabels based on ISO 15693 e.g. Tag-it/I-Code
MOBY E	13.56 MHz	0,1 m	752 byte EEPROM	350	+ 150 °C	Battery-free data memory
MOBY I	1.81 MHz	0,15 m	32 KB FRAM	1250	+ 85 °C or + 220 °C cyclic	Battery-free data memory

3.2 RF300

3.2.1 RF300 system overview

SIMATIC RF300 is an inductive identification system specially designed for use in industrial production for the control and optimization of material flow.

Thanks to its compact dimensions, RF300 is the obvious choice where installation conditions are restricted, especially for assembly lines, handling systems and workpiece carrier systems. RF300 is suitable for both simple and demanding RFID applications and it stands out for its persuasive price/performance ratio.

The RF300 offers a particularly low-cost solution concept for low-performance applications. The high-performance components of RF300 provide advantages in terms of speed.

System Components	RF300 for low-performance applications	RF300 for high-performance applications
Communication modules	8xIQ-Sense for ET 200M (PROFIBUS) and for direct connection to an S7-300	ASM 452, ASM 456 ASM 473 (PROFIBUS) ASM 475 (S7 300 / ET 200M) RF170C RF180C
Reader	RF310R with IQ-Sense interface	RF310R with RS422 interface RF340R with RS422 interface RF350R with RS422 interface RF380R with RS232 or RS422 interface
Transponder	RF320T RF340T RF350T RF360T	RF320T RF340T RF350T RF360T RF370T RF380T

Overview of RF300 low-performance and high-performance components

RF300 is ready for multi-tag operation, but in this expansion stage, only the faster single-tag operation is possible.

3.2.2 Application areas of RF300

SIMATIC RF300 is primarily used for non-contact identification of containers, palettes and workpiece holders in a closed production circuit. The data carriers (transponders) remain in the production chain and are not supplied with the products. SIMATIC RF300, with its compact transponder and reader enclosure dimensions, is particularly suitable in confined spaces.

Main applications

- Mechanical engineering, automation systems, conveyor systems
- Ancillary assembly lines in the automotive industry, component suppliers
- Small assembly lines

Application examples

- Production lines for engines, gearboxes, axles, etc.
- Assembly lines for ABS systems, airbags, brake systems, doors, cockpits, etc.
- Assembly lines for household electrical appliances, consumer electronics and electronic communication equipment
- Assembly lines for PCs, low-power motors, contactors, switches

Customer benefits

- Reading and writing of large data volumes within a short time enable reductions in product cycle times and thus help to boost productivity
- Can be used in harsh environments thanks to rugged components with high degree of protection
- Simple and low-cost system integration into SIMATIC S7 and PROFIBUS (TIA)
- Shorter startup times, and reductions in plant faults and downtimes thanks to integral diagnostics functionalities
- Cost savings thanks to maintenance-free components

3.2.3 RFID components and their function

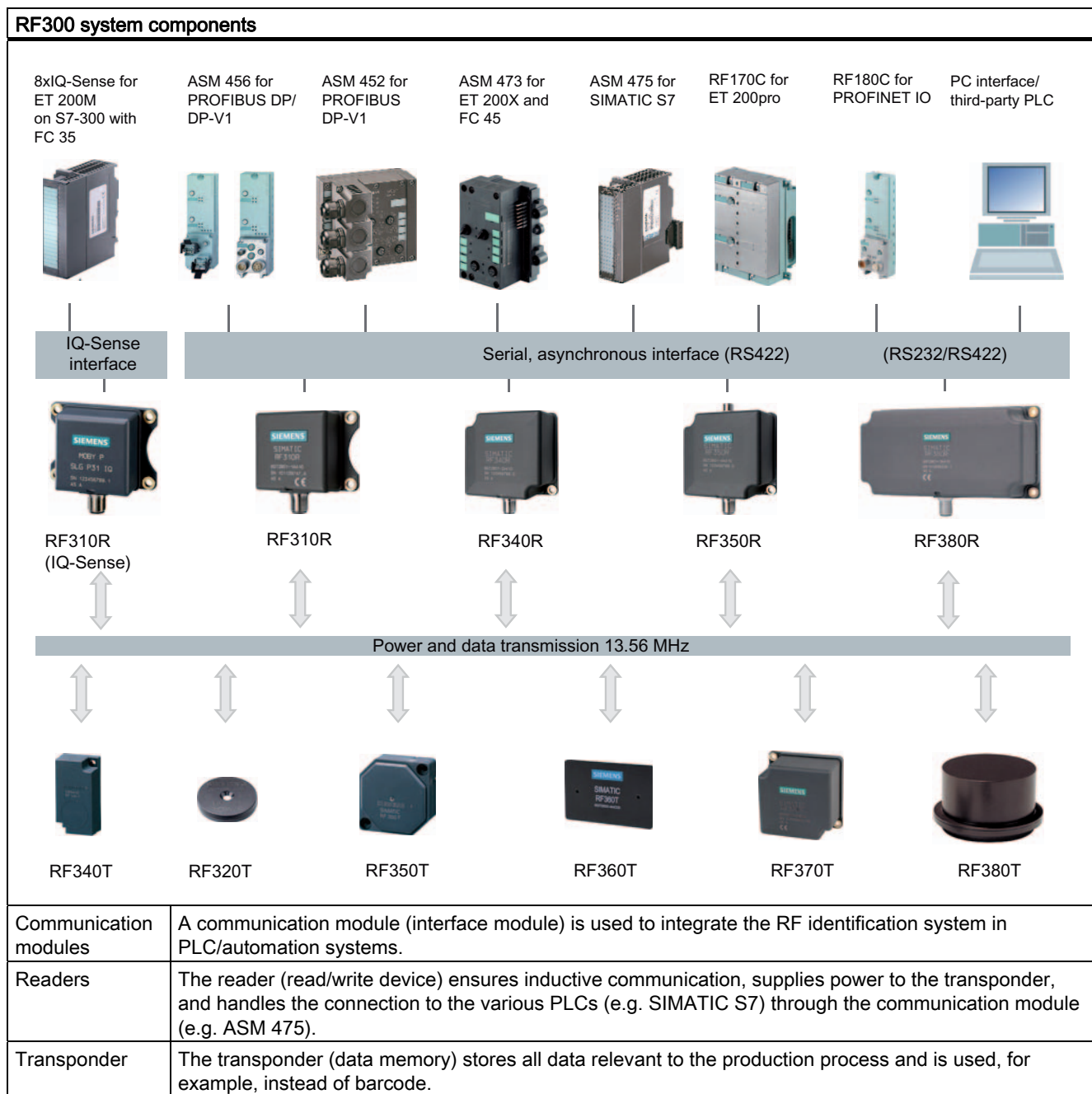

Conventions

The RF310R, RF340R and RF380R readers are equipped with an integral antenna, whereas the RF350R reader is operated over an external antenna. In this system manual, the term "Reader" is used throughout even where it is actually referring to the antenna of the reader.

3.2.4 Technical data

RFID system RF300	
Type	Inductive identification system for industrial applications
Transmission frequency data/energy	13.56 MHz
Memory capacity	20 bytes up to 64 KB user memory (r/w) 4 bytes fixed code as serial number (ro)
Memory type	EEPROM / FRAM
Write cycles	EEPROM: > 100 000 FRAM: Unlimited
Read cycles	Unlimited
Data management	Byte-oriented access
Data transfer rate Transponder-Reader	3 KB/s (approx.)
Write/read distance (system limit; depends on reader and transponder)	up to 0.15 m
Operating temperature	Reader: -25 °C to +70 °C Transponder: -40 °C to +85 °C +220 °C cyclic
Degree of protection	Reader: IP 67 ²⁾ Transponder: > IP 67
Can be connected to	SIMATIC S7-300, Profibus DP V1, PC ¹⁾ , non-Siemens PLC ¹⁾
Special features	High noise immunity Compact components Extensive diagnostic options A reader with IQ-Sense interface
Approvals	ETS 300 330 (Europe) FCC Part 15 (USA), UL/CSA CE

¹⁾ By means of RS422 interface and 3964R protocol

²⁾ Except RF350R: IP 65

RF300 system planning

4.1 Fundamentals of application planning

4.1.1 Selection criteria for SIMATIC RF300 components

Assess your application according to the following criteria, in order to choose the right SIMATIC RF300 components:

- Transmission distance (read/write distance)
- Tracking tolerances
- Static or dynamic data transfer
- Data volume to be transferred
- Speed in case of dynamic transfer
- Metal-free rooms for transponders and readers
- Ambient conditions such as relative humidity, temperature, chemical impacts, etc.

4.1.2 Transmission window and read/write distance

The reader generates an inductive alternating field. The field is strongest near to the reader. The strength of the field decreases in proportion to the distance from the reader. The distribution of the field depends on the structure and geometry of the antennas in the reader and transponder.

A prerequisite for the function of the transponder is a minimum field strength at the transponder achieved at a distance S_g from the reader or the ANT1. The picture below shows the transmission window between transponder and reader or ANT1:

Table 4-1 RF310R reader and ANT1 (RF350R) transmission window and read/write distance

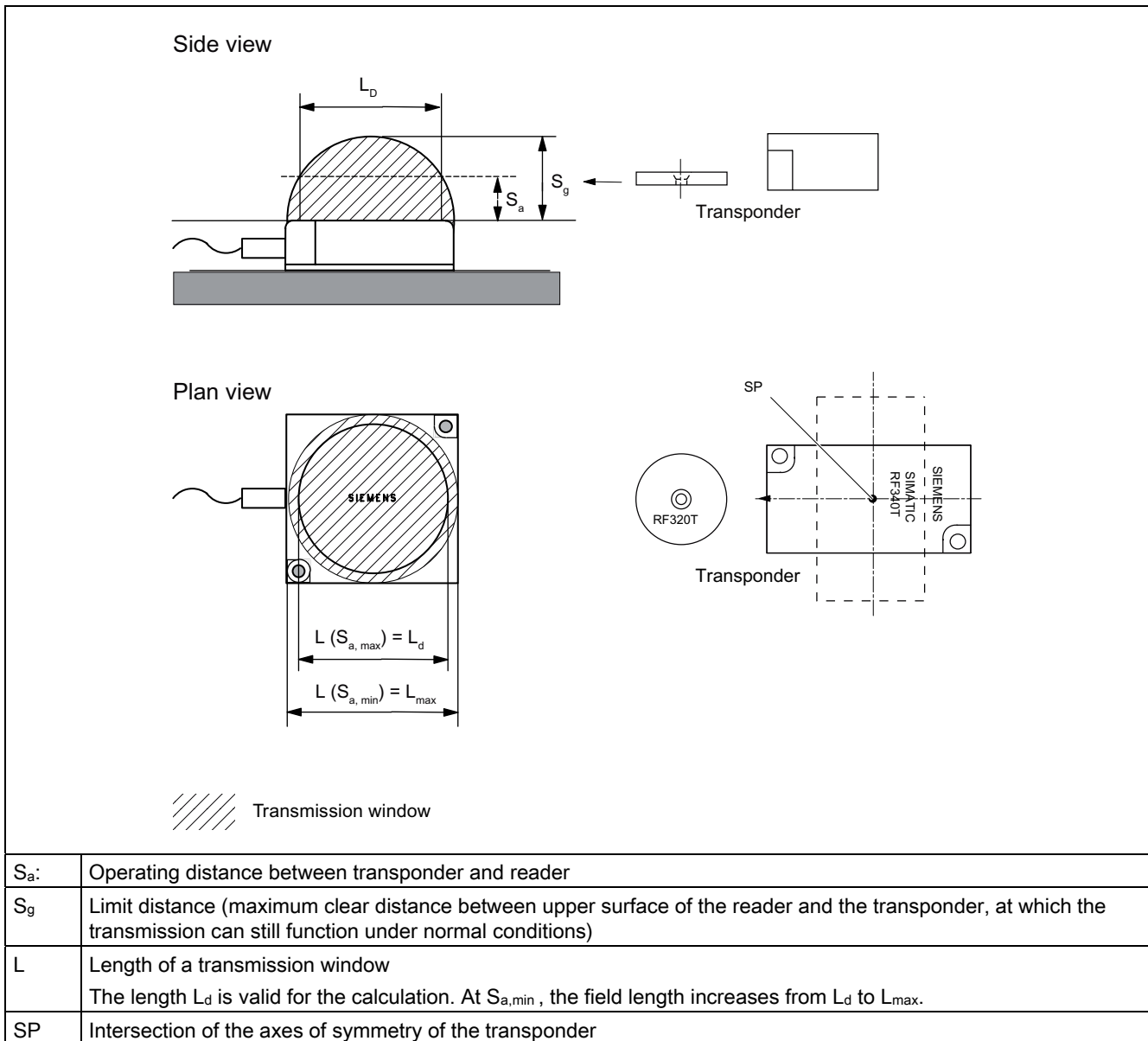
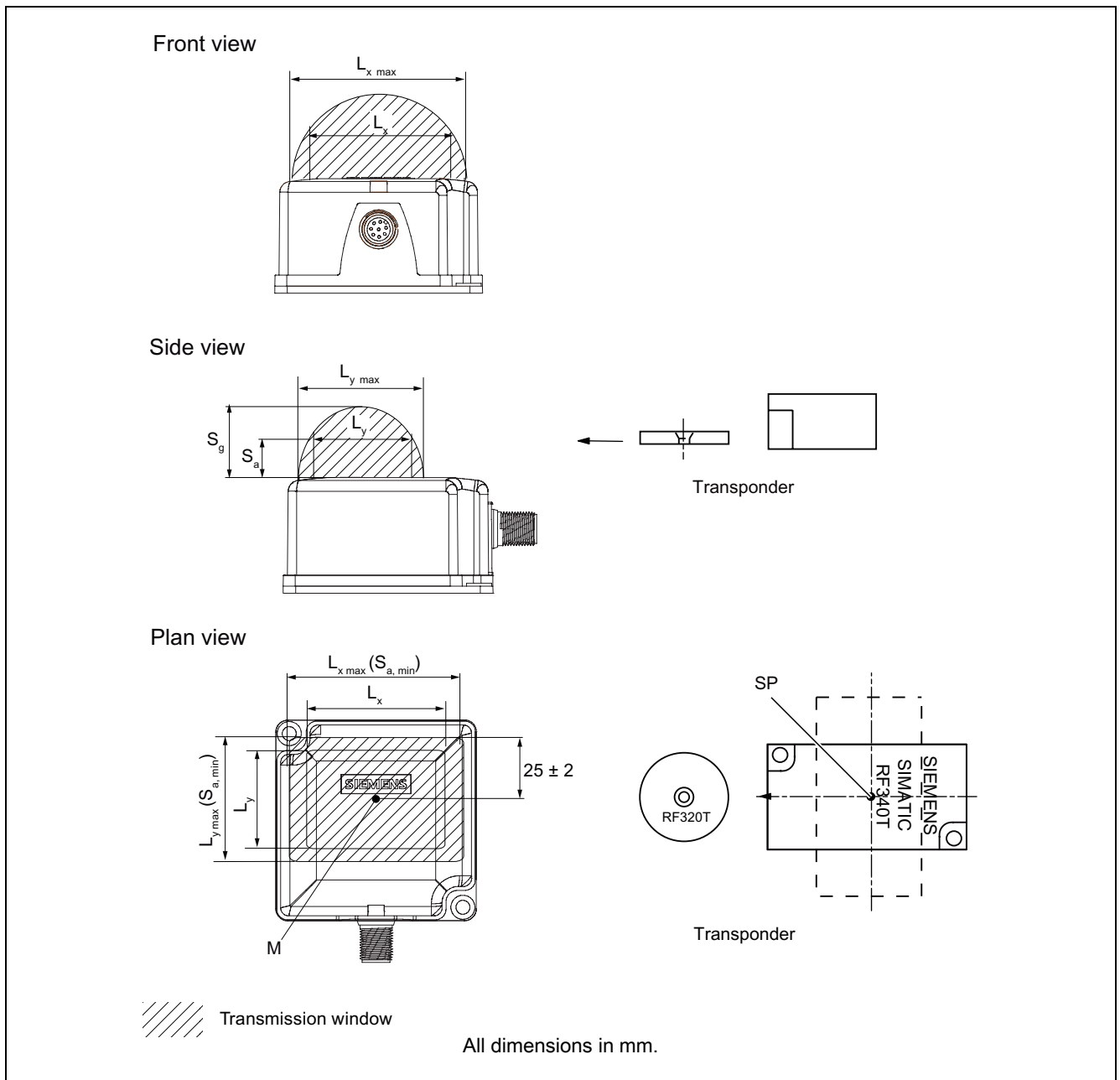
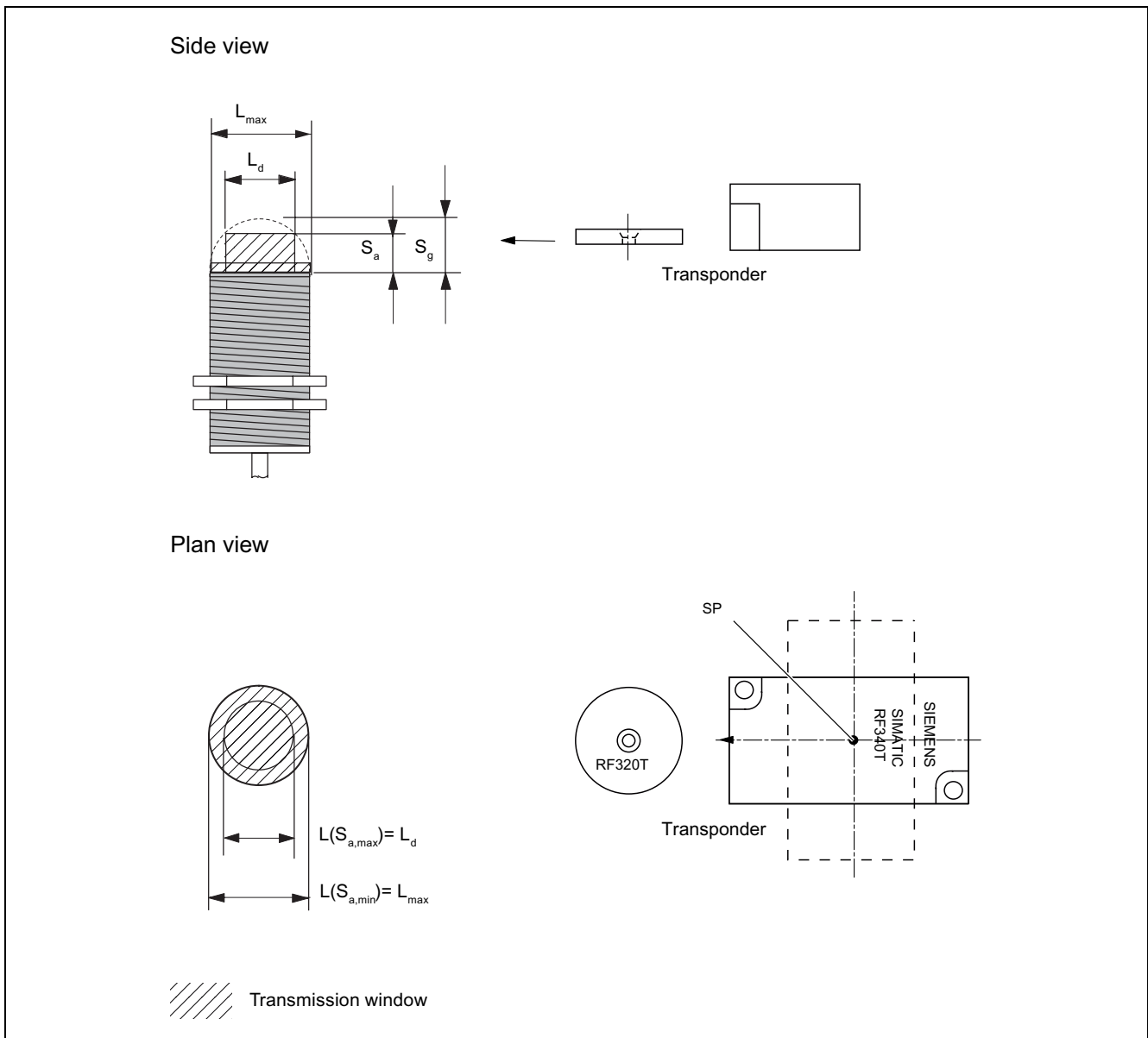

Table 4-2 RF340R reader transmission window and read/write distance



S _a :	Operating distance between transponder and reader
S _g	Limit distance (maximum clear distance between upper surface of the reader and the transponder, at which the transmission can still function under normal conditions)
L _x	Length of a transmission window in the x direction The length L _x is valid for the calculation. At S _{a,min} , the field length increases from L _x to L _{x,max} .
L _y	Length of a transmission window in the y direction The length L _y is valid for the calculation. At S _{a,min} , the field length increases from L _y to L _{y,max} .
M	Field centerpoint

Table 4-3 ANT18 and ANT30 (RF350R) transmission window and read/write distance



S_a :	Operating distance between transponder and reader
S_g	Limit distance (maximum clear distance between upper surface of the reader and the transponder, at which the transmission can still function under normal conditions)
L	Diameter of a transmission window The length L_d is valid for the calculation. At $S_{a,min}$, the field length increases from L_d to L_{max} .
SP	Intersection of the axes of symmetry of the transponder

Table 4-4 RF380R reader transmission window and read/write distance

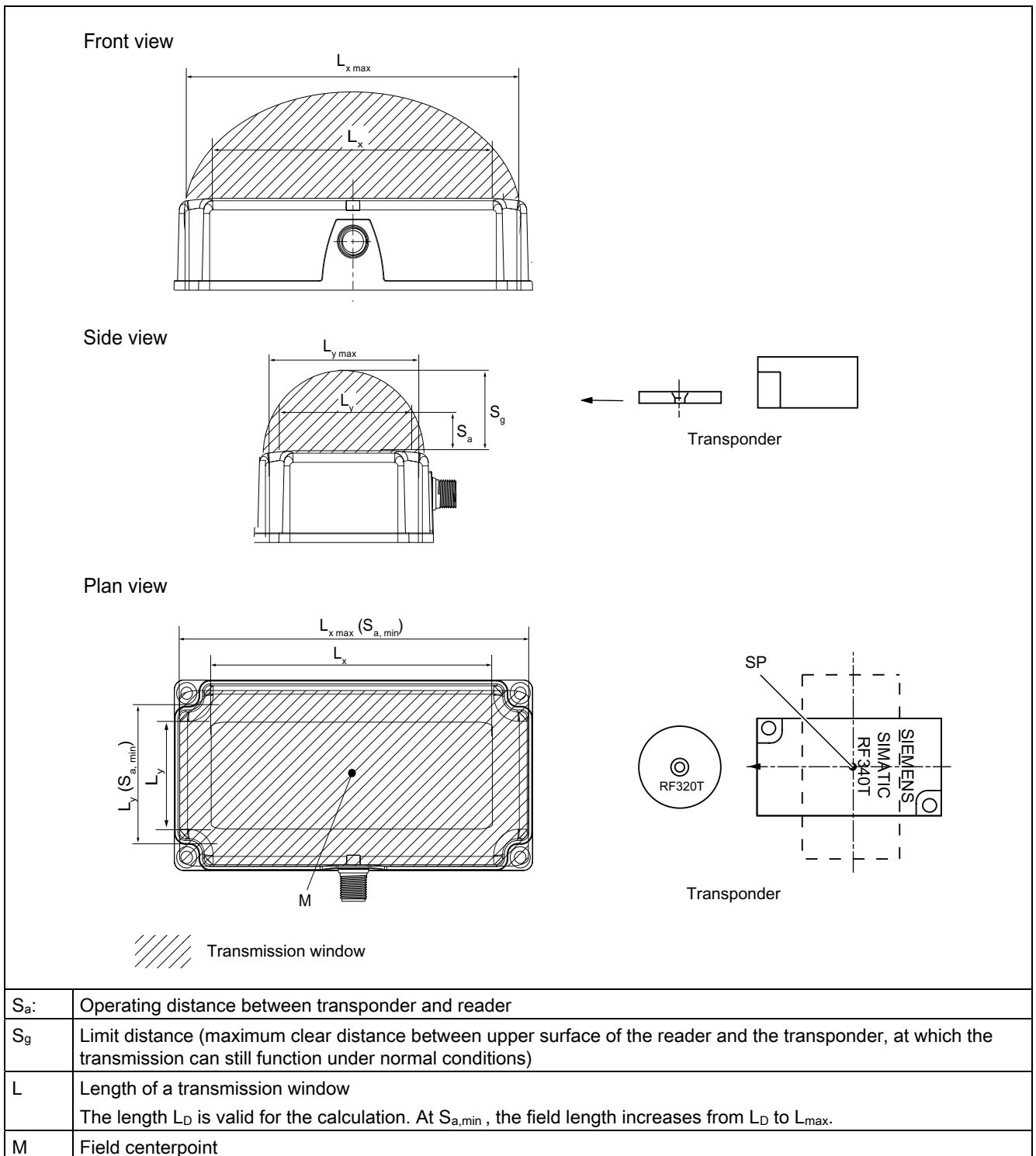

The transponder can be used as soon as the intersection (SP) of the transponder enters the area of the transmission window.

From the diagrams above, it can also be seen that operation is possible within the area between S_a and S_g . The active operating area reduces as the distance increases, and shrinks to a single point at distance S_g . Only static mode should thus be used in the area between S_a and S_g .

4.1.3 Width of the transmission window

Determining the width of the transmission window

The following approximation formula can be used for practical applications:

$$B = 0.4 \cdot L$$

- B: Width of the transmission window
L: Length of the transmission window

Tracking tolerances

The width of the transmission window (B) is particularly important for the mechanical tracking tolerance. The formula for the dwell time is valid without restriction when B is observed.

4.1.4 Impact of secondary fields

Secondary fields in the range from 0 to 20 mm always exist. They should only be applied during planning in exceptional cases, however, since the read/write distances are very limited. Exact details of the secondary field geometry cannot be given, since these values depend heavily on the operating distance and the application.

4.1.5 Permissible directions of motion of the transponder

Active area and direction of motion of the transponder

The transponder and reader have **no** polarization axis, i.e. the transponder can come in from any direction, be placed at any position, and cross the transmission window. The figure below shows the active area for various directions of transponder motion:

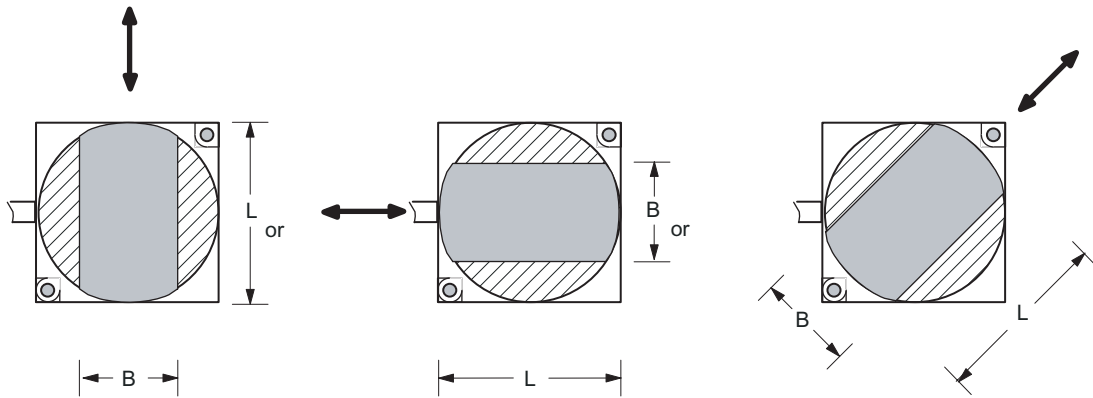

Figure 4-1 Active areas of the transponder for different directions of transponder motion

4.1.6 Operation in static and dynamic mode

Operation in static mode

If working in static mode, the transponder can be operated up to the limit distance (S_g). The transponder must then be positioned exactly over the reader:

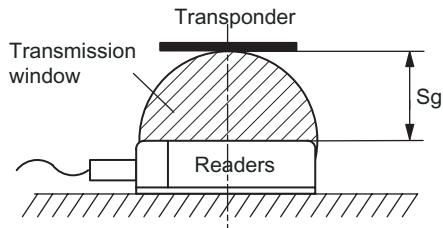

Figure 4-2 Operation in static mode

Operation in dynamic mode

When working in dynamic mode, the transponder moves past the reader. The transponder can be used as soon as the intersection (SP) of the transponder enters the circle of the transmission window. In dynamic mode, the operating distance (S_a) is of primary importance.

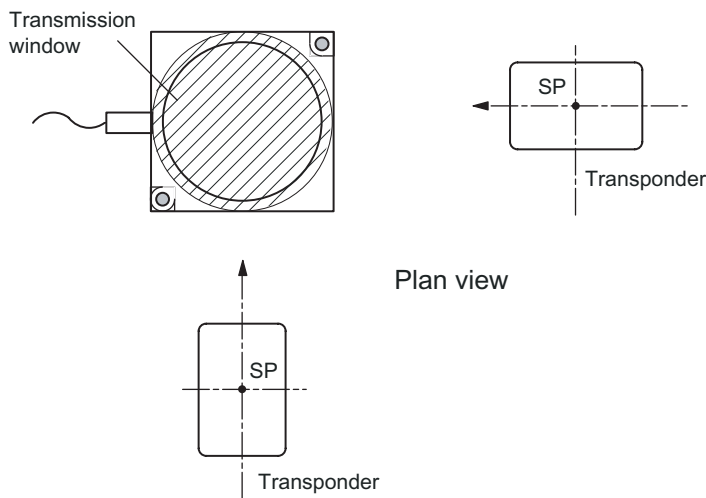

Figure 4-3 Operation in dynamic mode

4.1.7 Dwell time of the transponder

The dwell time is the time in which the transponder remains within the transmission window of a reader. The reader can exchange data with the transponder during this time.

The dwell time is calculated thus:

$$t_v = \frac{L \cdot 0,8 [m]}{v_{\text{tag}} [m/s]}$$

- t_v: Dwell time of the transponder
- L: Length of the transmission window
- v_{Tag}: Speed of the transponder (tag) in dynamic mode
- 0,8: Constant factor used to compensate for temperature impacts and production tolerances

The dwell time can be of any duration in static mode. The dwell time must be sufficiently long to allow communication with the transponder.

The dwell time is defined by the system environment in dynamic mode. The volume of data to be transferred must be matched to the dwell time or vice versa. In general:

$$t_v \geq t_k$$

- t_v: Dwell time of the data memory within the field of the reader
- t_k: Communication time between transponder and communication module

4.1.8 Communication between communication module, reader (with IQ-Sense interface) and transponder

Communication between the communication module (IQ-Sense), RF310R reader and transponder takes place in fixed telegram cycles. 3 cycles of approximately 3 ms are always needed for the transfer of a read or write command. 1 or 2 bytes of user data can be transferred with each of these commands. The acknowledgement transfer (status or read data) takes place in 3 further cycles. The transponder must be present within the field of the reader during the message frame cycle.

Calculation of the communication time for interference-free transfer

The communication time for fault-free data transfer is calculated as follows:

$$t_k = K + t_{Byte} \cdot n \quad (n \geq 1)$$

Calculation of the maximum amount of user data

The maximum amount of user data is calculated as follows:

$$n_{max} = \frac{t_v - K}{t_{Byte}}$$

- t_k Communication time between communication module, RF310R IQ-Sense reader and transponder
- t_v Dwell time
- n Amount of user data in bytes
- n_{max} Max. amount of user data in bytes in dynamic mode
- t_{Byte} Transmission time for 1 byte
- K Constant (internal system time) This contains the time for power buildup on the transponder and for command transfer

Time constants K and t_{Byte}

K (ms)	t _{Byte} (ms)	Command
15	15	Read (FRAM/EEPROM area)
15	15	Write (FRAM area)
30	30	Write (EEPROM area)

The table of time constants applies to every command. If a user command consists of several subcommands, the above t_k formula must be applied to each subcommand.

4.1.9 Calculation example (IQ-Sense)

A transport system moves pallets with transponders at a maximum velocity of $V_{\text{Tag}} = 0.14$ m/s. The following RFID components were chosen:

- 8xIQ-Sense module
- Reader RF310R
- Transponder RF340T

Task specification

- a) The designer of the plant is to be given mechanical specifications.
- b) The programmer should be given the maximum number of words in dynamic mode.

Refer to the tables in the "Field data of transponders and readers" section for the technical data.

Determine tolerance of pallet transport height

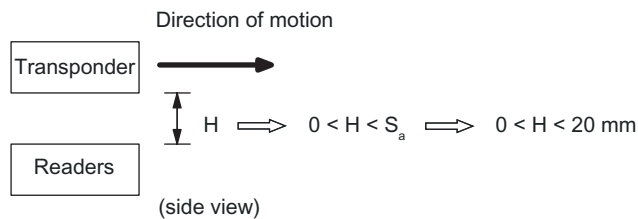

Figure 4-4 Tolerance of pallet transport height

Determine tolerance of pallet side transport

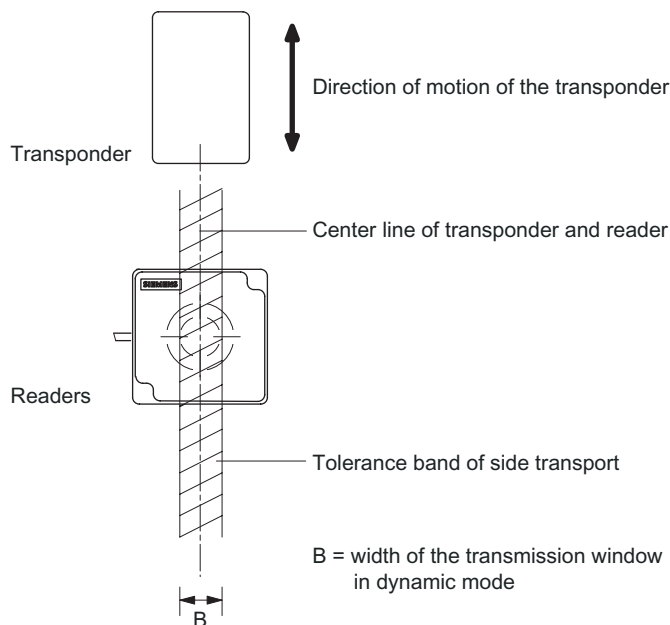

Figure 4-5 Tolerance of pallet side transport

Minimum distance from reader to reader

Refer to the field data of the reader for this value.

Minimum distance from transponder to transponder

Refer to the field data of the transponder for this value.

Calculation of the maximum amount of user data in dynamic mode

Step		Formula/calculation
1.	Calculate dwell time of the transponder	Refer to the "Field data of all transponders and readers" table for value L. Value $v_{Tag} = 0.14\text{m/s}$ $t_v = \frac{L \cdot 0,8}{v_{Tag}} = \frac{0,038\text{ m} \cdot 0,8}{0,14\text{ m/s}} = 0,217\text{ s} = 217\text{ ms}$
2.	Calculate maximum user data (n_{max}) for reading	Take value t_v from Step 1. Take values K and t_{Byte} from Table "Time constants K and t_{Byte} ". Read: $\frac{t_v - K}{t_{Byte}} = \frac{217\text{ms} - 15\text{ms}}{15\text{ms}} = 13.47 \Rightarrow n_{max.} = 13\text{ byte}$
3.	Calculate maximum user data (n_{max}) for writing (FRAM area)	Take value t_v from Step 1. Take values K and t_{Byte} from Table "Time constants K and t_{Byte} ". Write: $\frac{t_v - K}{t_{Byte}} = \frac{217\text{ms} - 15\text{ms}}{15\text{ms}} = 13.47 \Rightarrow n_{max.} = 13\text{ byte}$

Result

A maximum of 13 bytes can be read or written when passing the transponder.

4.1.10 Communication between communication module, reader (with RS422 interface) and transponder

Communication between the communication module, reader and transponder takes place asynchronously through the RS422 interface. Depending on the communication module (ASM) used, transmission rates of 19200 bytes, 57600 bytes or 115200 bytes can be selected.

Calculation of the communication time for interference-free transfer

The communication time for fault-free data transfer is calculated as follows:

$$t_K = K + t_{\text{Byte}} \cdot n \quad (n \geq 1)$$

If the transmission is interrupted briefly due to external interference, the communication module automatically continues the command.

Calculation of the maximum amount of user data

The maximum amount of user data is calculated as follows:

$$n_{\text{max}} = \frac{t_V - K}{t_{\text{Byte}}}$$

- t_k: Communication time between communication module, reader and transponder
- t_v: Dwell time
- n: Amount of user data in bytes
- n_{max}: Max. amount of user data in bytes in dynamic mode
- t_{byte}: Transmission time for 1 byte
- K: Constant; the constant is an internal system time. This contains the time for power buildup on the transponder and for command transfer

Time constants K and t_{byte}

Transmission rate [baud]	K [ms]	t_{byte} [ms]
19200	28	0,85
57600	14	0,38
115200	11	0,28

The values for K and t_{byte} include the overall time that is required for communication in static mode. It is built up from several different times:

- Serial communication between communication module, reader and
- Processing time between reader and transponder and their internal processing time.

The values shown in the table must be used when calculating the maximum quantity of user data in static mode. They are applicable for both reading and writing in the FRAM area. For writing in the EEPROM area (max. 20 bytes), the byte time t_{Byte} is approx. 11 ms.

Transmission rate [baud]	Memory area	K [ms]	t_{byte} [ms]
Independent	FRAM	8,5	0,13
Independent	EEPROM	8,5	12,2
Write			
Read			

In dynamic mode, the values for K and t_{byte} are independent of the transmission speed. The communication time only includes the processing time between the reader and the transponder and the internal system processing time of these components. The communication times between the communication module and the reader do not have to be taken into account because the command for reading or writing is already active when the transponder enters the transmission field of the reader.

The values shown above must be used when calculating the maximum quantity of user data in dynamic mode. They are applicable for both writing and reading.

4.1.11 Calculation example (RS422)

A transport system moves pallets with transponders at a maximum velocity of $V_{\text{Tag}} = 1.0 \text{ m/s}$ (dynamic mode). The following RFID components were selected:

- Communication module ASM 475
- RF310R reader with RS422 interface
- Transponder RF340T

Task

- a) The designer of the plant is to be given mechanical specifications.
- b) The programmer should be given the maximum number of bytes in dynamic mode.

Refer to the tables in the "Field data of transponders and readers" section for the technical data.

Determine tolerance of pallet transport height

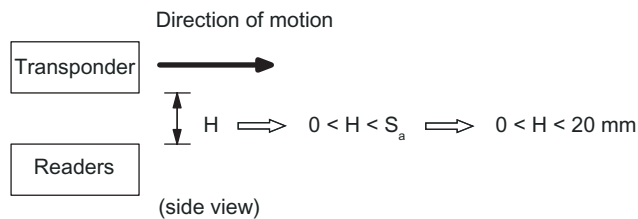

Figure 4-6 Tolerance of pallet transport height

Determine tolerance of pallet side transport

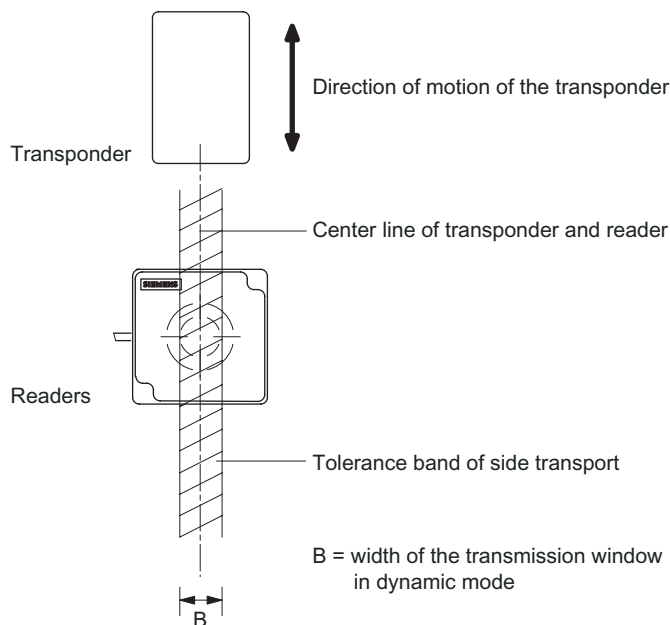

Figure 4-7 Tolerance of pallet side transport

Minimum distance from reader to reader

Refer to the field data of the reader for this value.

Minimum distance from transponder to transponder

Refer to the field data of the transponder for this value.

Calculation of the maximum amount of user data in dynamic mode

Step		Formula/calculation
1.	Calculate dwell time of the transponder	Refer to the "Field data of all transponders and readers" table for value L. Value $v_{Tag} = 1,00 \text{ m/s}$ $t_v = \frac{L \cdot 0,8}{v_{Tag}} = \frac{0,038 \text{ m} \cdot 0,8}{1,0 \text{ m/s}} = 0,0304 \text{ s} = 30,4 \text{ ms}$
2.	Calculate maximum user data (n_{max}) for reading or writing (FRAM area)	Take value t_v from Step 1. Take values K and t_{Byte} from Table "Time constants K and t_{Byte} ". read/write: $\frac{t_v - K}{t_{Byte}} = \frac{30,4 \text{ ms} - 8,5 \text{ ms}}{0,13 \text{ ms}} = 168,46 \Rightarrow n_{max} = 168 \text{ Byte}$

Result

A maximum of 168 bytes can be read or written when passing the transponder.

4.2 Field data for transponders, readers and antennas

The following table shows the field data for all SIMATIC RF300 components of transponders and readers. It facilitates the correct selection of a transponder and reader.

All the technical specifications listed are typical data and are applicable for an ambient temperature of between 0 °C and +50 °C, a supply voltage of between 22 V and 27 V DC and a metal-free environment. **Tolerances of ±20 % are admissible due to production or temperature conditions.**

If the entire voltage range at the reader of 20 V DC to 30 V DC and/or the entire temperature range of transponders and readers is used, the field data are subject to further tolerances.







Note

Transmission gaps

If the minimum operating distance (S_a) is not observed, a transmission gap can occur in the center of the field. Communication with the transponder is not possible in the transmission gap.

Field data of all transponders and readers without interference from metal

Table 4-5 Reader RF310R

	RF320T	RF340T	RF350T	RF360T	RF370T	RF380T
						
RF310R						
Length of the transmission window (L)	30 mm	38 mm	45 mm	45 mm	Combination with the RF310R is basically possible, but is not recommended because the antenna geometries for the reader and transponder are not ideally matched.	
Operating distance (S_a)	1...10 mm	1...20 mm	2...22 mm	2...26 mm		
Limit distance (S_g)	16 mm	26 mm	30 mm	35 mm		

4.2 Field data for transponders, readers and antennas

	RF320T	RF340T	RF350T	RF360T	RF370T	RF380T
RF340R 						
Length of the transmission window (L_x)	45 mm	60 mm	60 mm	70 mm	75 mm	85 mm
Width of the transmission window (L_y)	40 mm	45 mm	50 mm	60 mm	65 mm	75 mm
Operating distance (S_a)	1...20 mm	2...25 mm	5...35 mm	8...40 mm	15...36 mm	15...47 mm
Limit distance (S_g)	25 mm	35 mm	50 mm	60 mm	52 mm	55 mm

	RF320T	RF340T	RF350T	RF360T	RF370T	RF380T
RF350R / ANT1 						
Length of the transmission window (L)	45 mm	60 mm	60 mm	70 mm	70 mm	88 mm
Operating distance (S_a)	1...20 mm	2...25 mm	5...35 mm	8...40 mm	15...45 mm	15...53 mm
Limit distance (S_g)	25 mm	35 mm	50 mm	60 mm	65 mm	65 mm

	RF320T	RF340T	RF350T	RF360T	RF370T	RF380T
RF350R / ANT18 						
Diameter of the transmission window (L_d)	10 mm	20 mm	Not yet released			
Operating distance (S_a)	1...8 mm	1...10 mm				
Limit distance (S_g)	10 mm	13 mm				

	RF320T	RF340T	RF350T	RF360T	RF370T	RF380T
RF350R / ANT30						
						
Diameter of the transmission window (L_d)	15 mm	25 mm	25 mm	Not yet released		
Operating distance (S_a)	0...11 mm	0...15 mm	0...16 mm			
Limit distance (S_g)	15 mm	20 mm	22 mm			

	RF320T	RF340T	RF350T	RF360T	RF370T	RF380T
RF380R						
						
Length of the transmission window (L_x)	100 mm	115 mm	120 mm	145 mm	135 mm	155 mm
Width of the transmission window (L_y)	40 mm	50 mm	60 mm	72 mm	65 mm	75 mm
Operating distance (S_a)	0...30 mm	10...50 mm	20...70 mm	40...85 mm	35...85 mm	25...85 mm
Limit distance (S_g)	47 mm	90 mm	105 mm	120 mm	125 mm	125 mm

- A maximum mean deviation of ± 2 mm is possible in static mode (without affecting the field data)
- This is reduced by approx. 15 % if the transponder enters the transmission window laterally (see also "Transmission window" figure)

Minimum distance from transponder to transponder

RF320T	RF340T	RF350T	RF360T	RF370T	RF380T
≥ 100 mm	≥ 100 mm	≥ 200 mm	≥ 300 mm	≥ 400 mm	≥ 500 mm

Minimum distance from reader to reader

RF310R to RF310R	RF340R to RF340R	RF350R to RF350R	RF380R to RF380R
≥ 400 mm	≥ 500 mm	≥ 500 mm	≥ 500 mm

Minimum distance from antenna to antenna

ANT1	ANT18	ANT30
≥ 800 mm	≥ 125 mm	≥ 200 mm

<p>NOTICE</p> <p>Adherence to the values specified in the "Minimum distance from reader to reader" table is essential. The inductive fields may be affected if the distance is smaller. In this case, the data transfer time would increase unpredictably or a command would be aborted with an error.</p>

If the specified minimum distance cannot be complied with due to the physical configuration, the SET-ANT command can be used to activate and deactivate the HF field of the reader. The application software must be used to ensure that only one reader is active (antenna is switched on) at a time.

4.3 Relationship between the volume of data and the transponder speed

4.3.1 RF310R with IQ-Sense

The curves shown here show the relationship between the speed of the RF320T and RF340T transponders and the volume of data transferred.

RF310R (IQ-Sense) with RF320T/RF340T

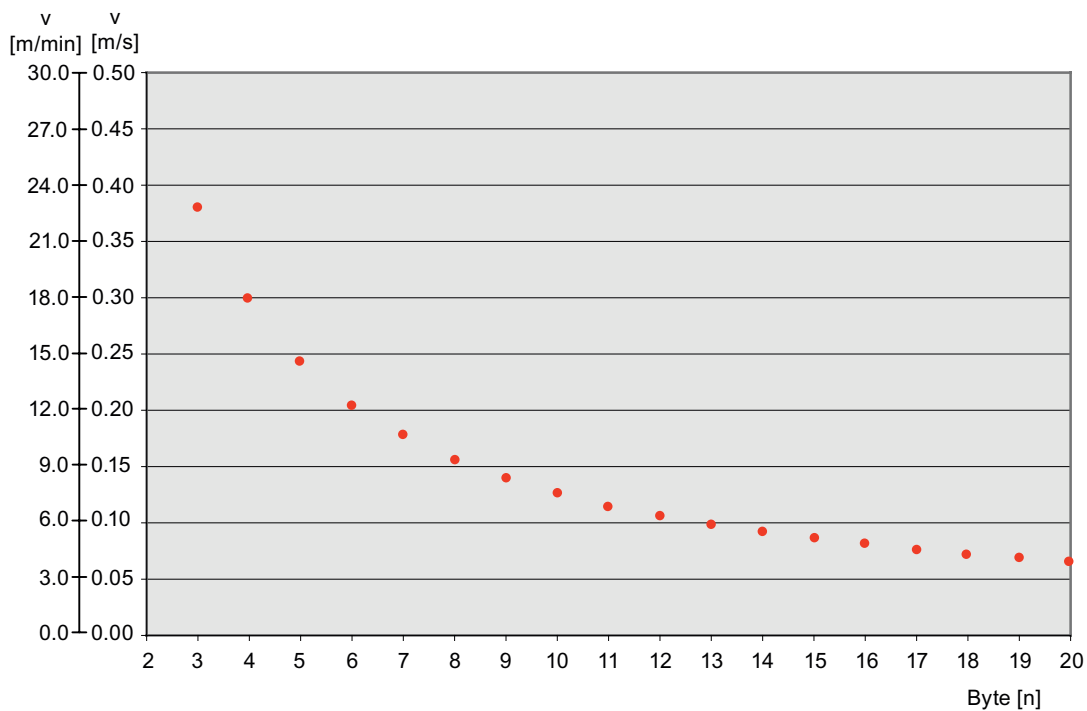

Figure 4-8 Relationship between speed and volume of data when using the RF310R (IQ-Sense)

4.3.2 RF310R with RS422

The curves depicted here show the relationship between the speed of the RF320T, RF340T, RF350T and RF360T transponders and the RF310R reader with RS422 interface and the corresponding volume of data.

They should make it easier to preselect the transponders for dynamic use.

The following table is used to calculate the curves.

The indicated speeds are applicable for operation without presence check.

	RF320T	RF340T	RF350T	RF360T
Length of the transmission window (L)	30 mm	38 mm	45 mm	45 mm
Operating distance (S _a)	10 mm	20 mm	22 mm	26 mm

RF310R with RF320T, RF340T, RF350T and RF360T (reading and writing EEPROM)

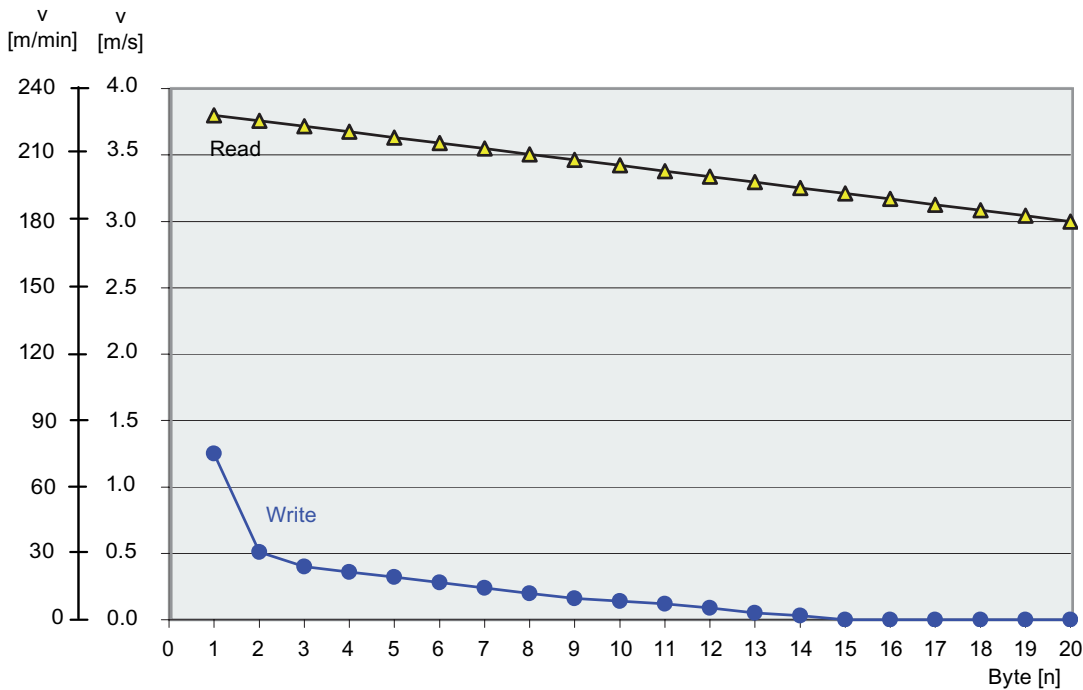

Figure 4-9 Relationship between speed and volume of data (reading and writing EEPROM) when using the RF310R (RS422) and RF320T

RF310R with RF340T (FRAM)

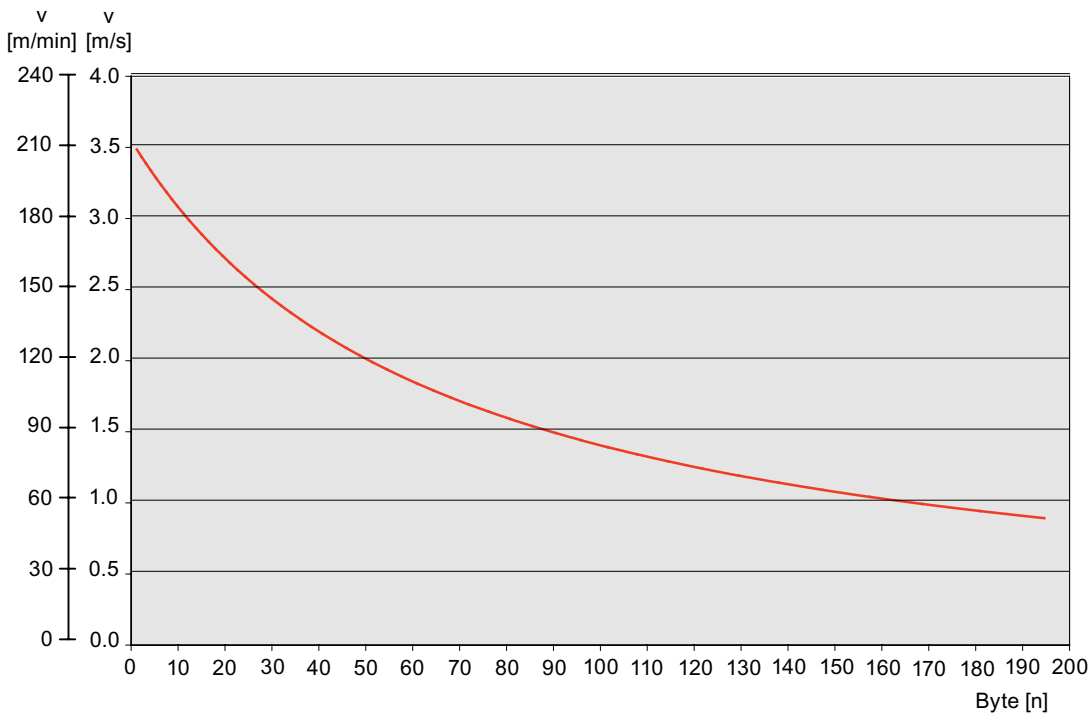

Figure 4-10 Relationship between speed and volume of data (reading/writing) when using the RF310R (RS422) and RF340T

RF310R with RF350T/RF360T (FRAM)

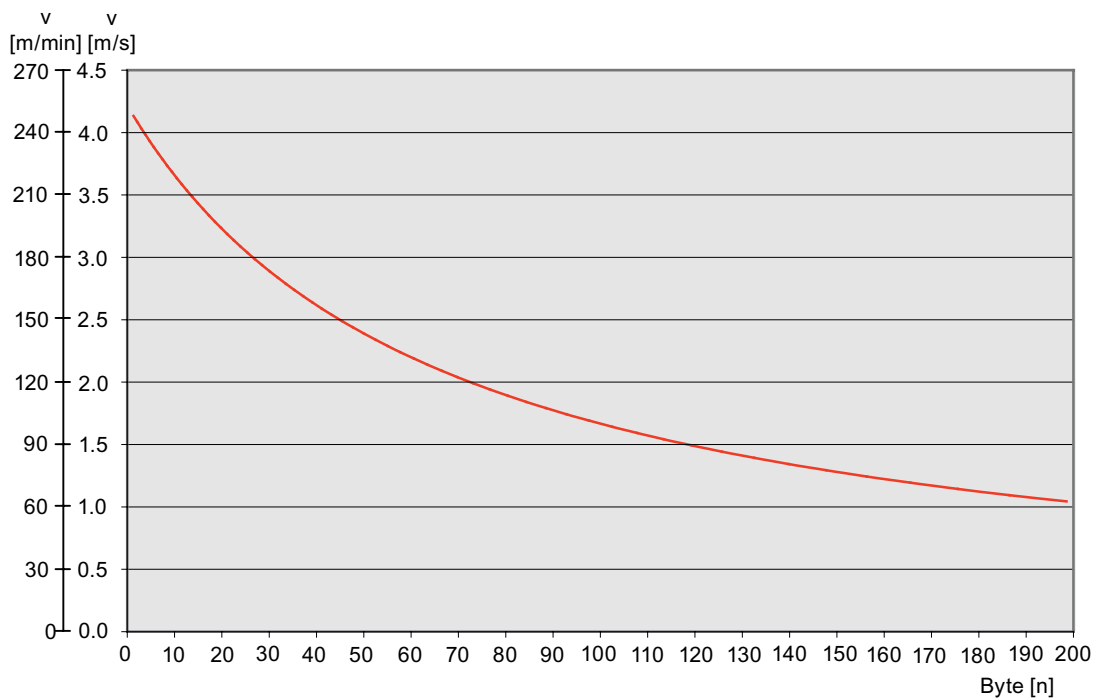

Figure 4-11 Relationship between speed and volume of data (reading/writing) when using the RF310R (RS422) and RF350T/RF360T

4.3.3 RF340R and RF350R

The curves shown here show the relationship between the speed of the RF320T, RF340T, RF350T, RF360T, RF370T and RF380T transponders and the RF340R/RF350R reader with ANT1 and the corresponding volume of data.

They should make it easier to preselect the transponders for dynamic use.

The following table is used to calculate the curves.

The indicated speeds are applicable for operation without presence check.

	RF320T	RF340T	RF350T	RF360T	RF370T	RF380T
Length of the transmission window (L)	30 mm	38 mm	45 mm	45 mm	75 mm	68 mm
Operating distance (S _a)	10 mm	20 mm	22 mm	26 mm	22 mm	22 mm

RF340R/RF350R with ANT1 and RF320T (EEPROM)

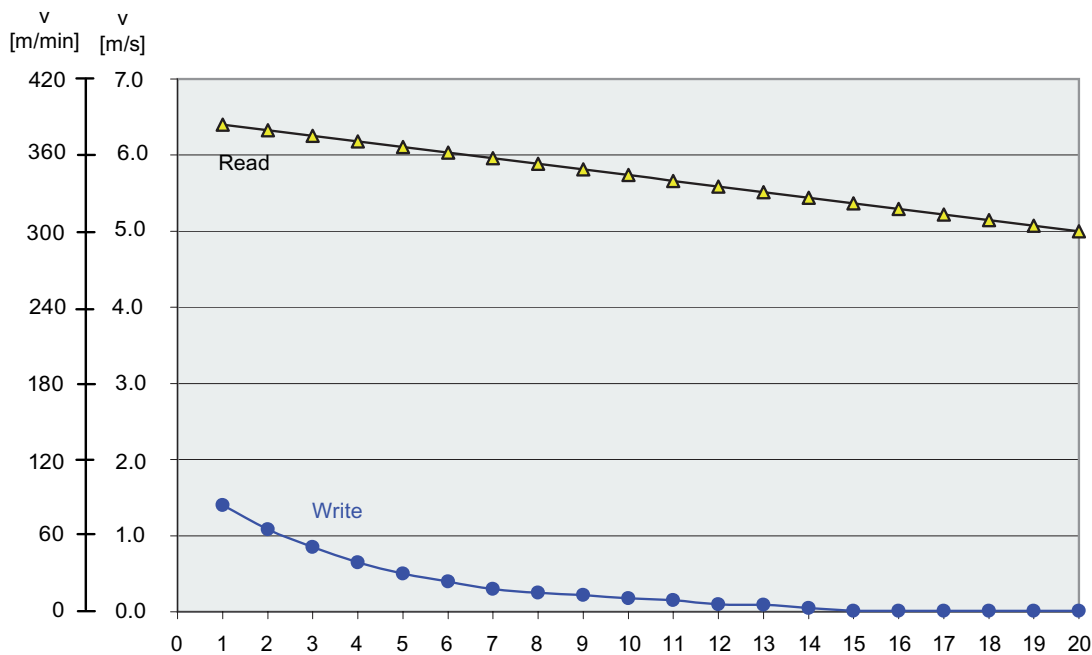

Figure 4-12 Relationship between speed and volume of data (reading/writing EEPROM) in dynamic operation when using the RF340R/RF350R with ANT1 and RF320T

RF340R/RF350R with ANT1 and RF340T/350T (EEPROM)

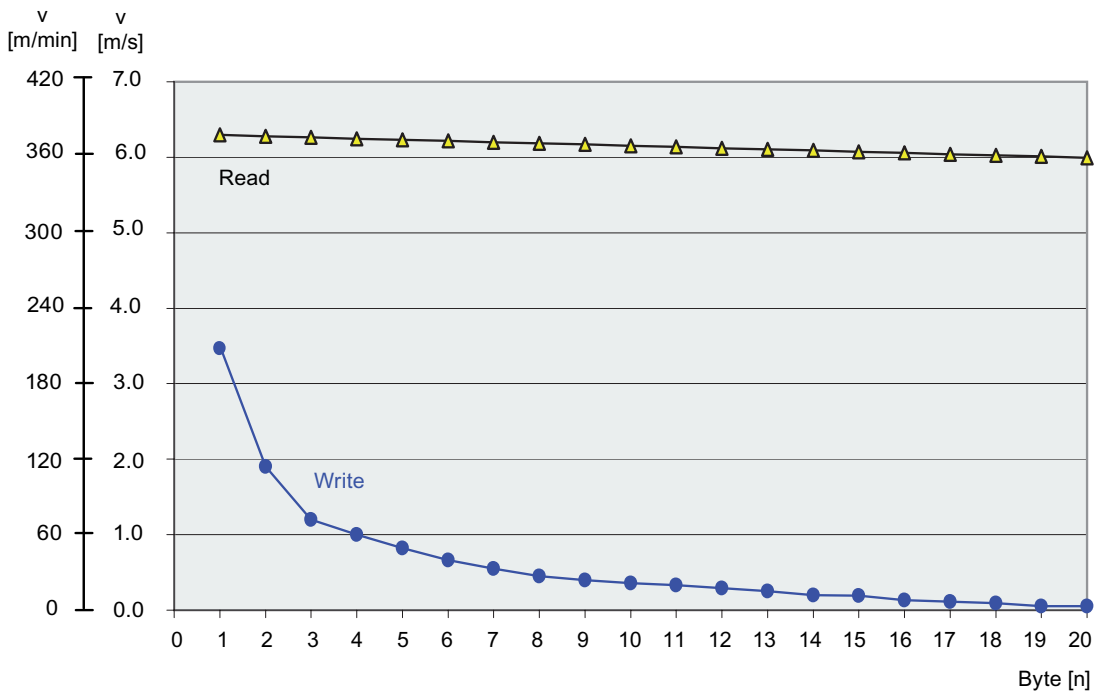

Figure 4-13 Relationship between speed and volume of data (reading/writing EEPROM) in dynamic operation when using the RF340R/RF350R with ANT1 and RF340T/350T

RF340R/RF350R with ANT1 and RF340T (FRAM)

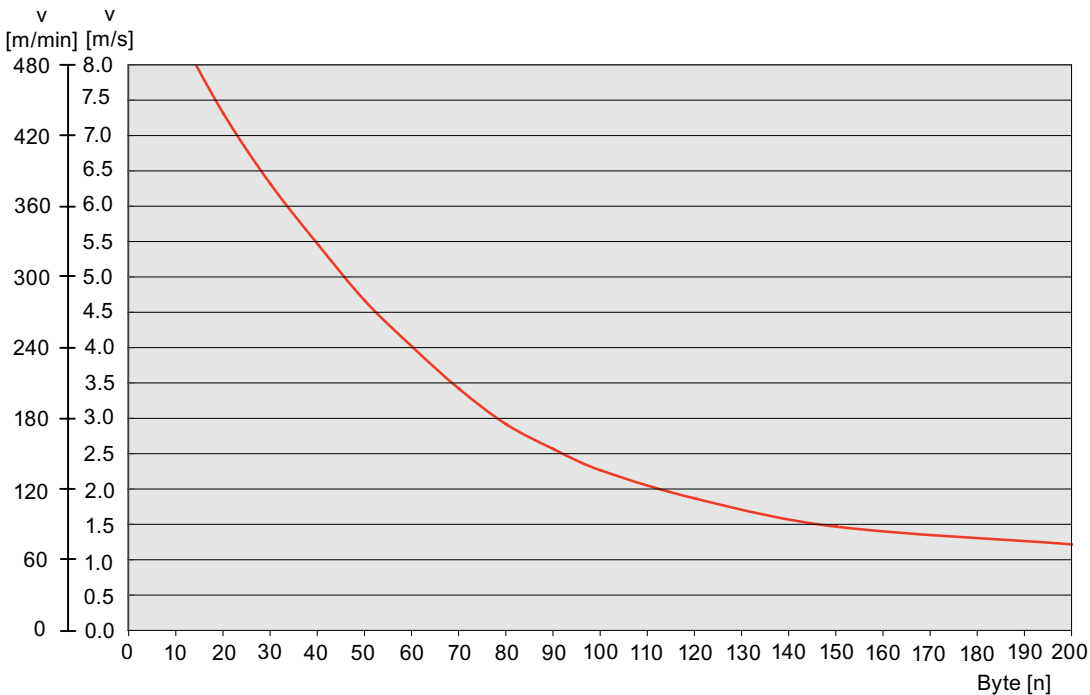

Figure 4-14 Relationship between speed and volume of data (reading/writing FRAM) in dynamic operation when using the RF340R/RF350R with ANT1 and RF340T

RF340R/RF350R with ANT1 and RF350T (FRAM)

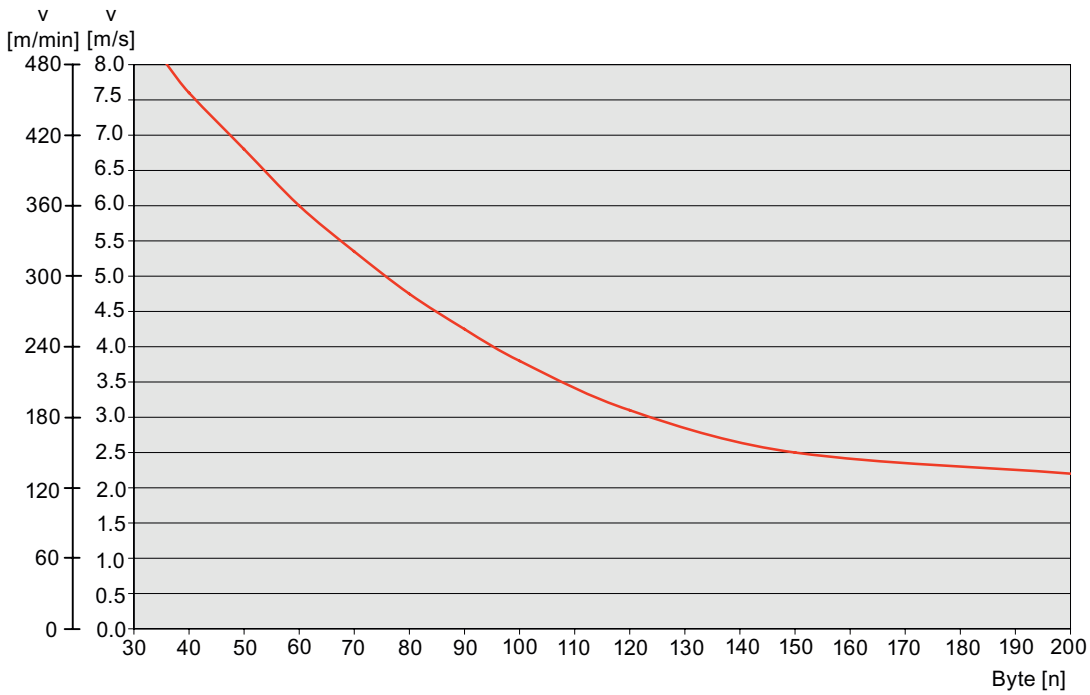

Figure 4-15 Relationship between speed and volume of data (reading/writing FRAM) in dynamic operation when using the RF340R/RF350R with ANT1 and RF350T

RF340R/RF350R with ANT1 and RF360T/370T/380T (EEPROM)

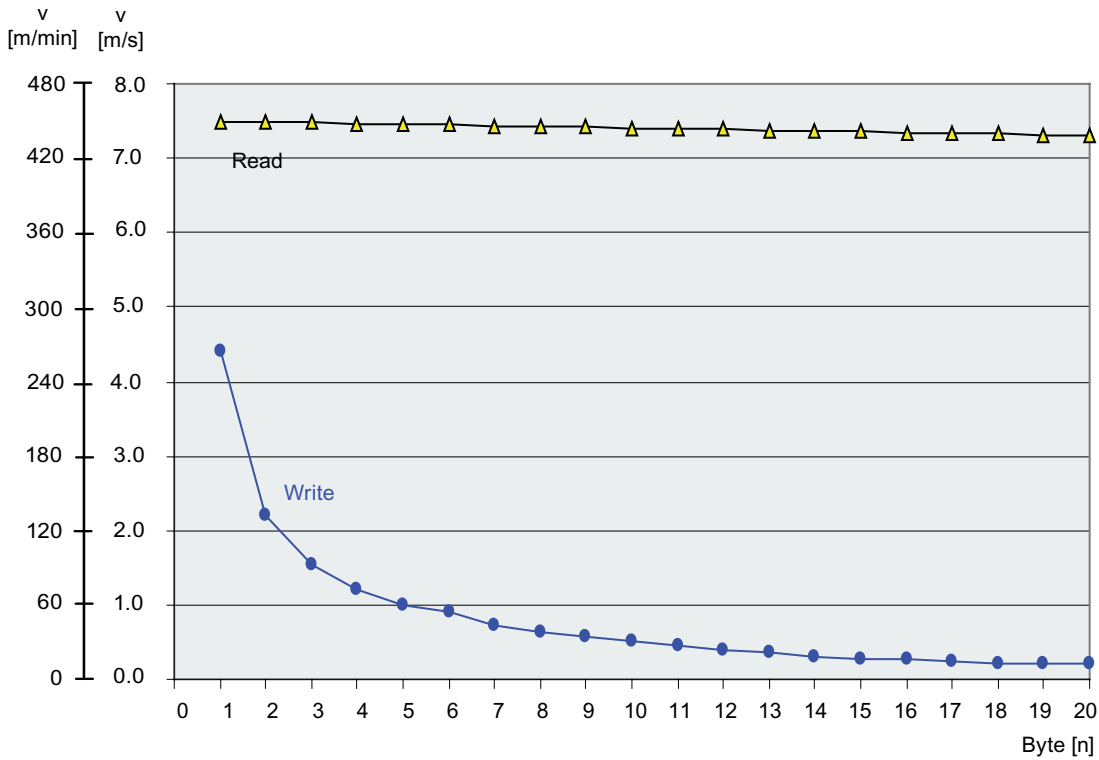

Figure 4-16 Relationship between speed and volume of data (reading/writing EEPROM) in dynamic operation when using the RF340R/RF350R with ANT1 and RF360T/370T/380T

RF340R/RF350R with ANT1 and RF360T (FRAM)

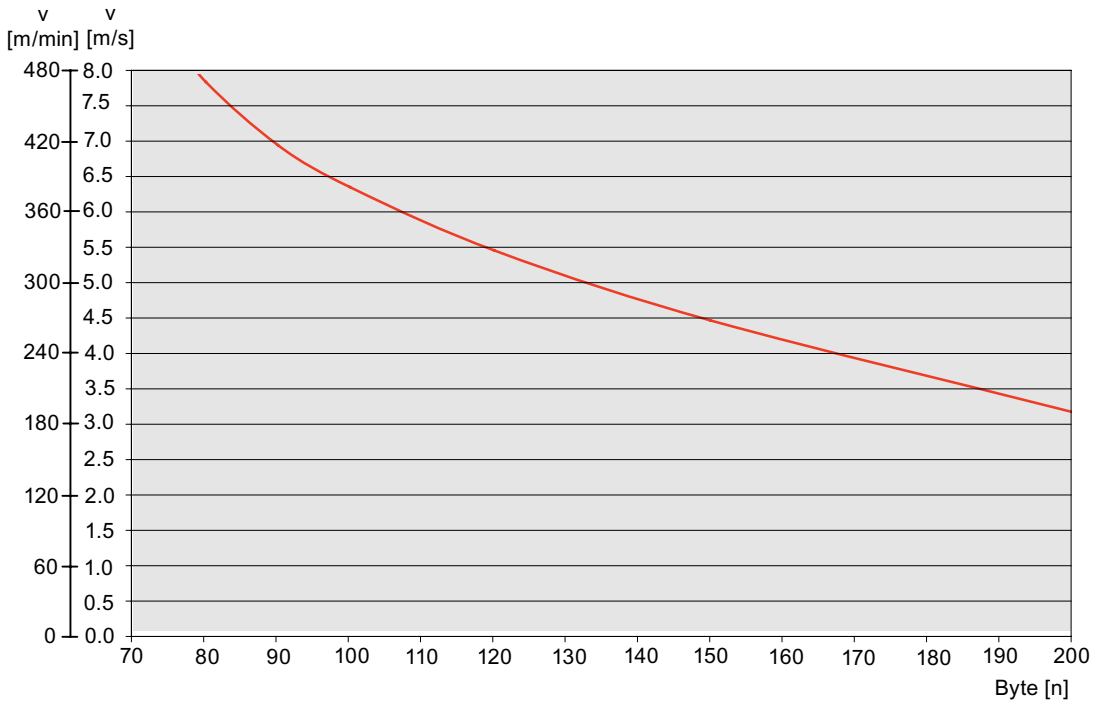

Figure 4-17 Relationship between speed and volume of data (reading/writing FRAM) in dynamic operation when using the RF340R/RF350R with ANT1 and RF360T

RF340R/RF350R with ANT1 and RF370T (FRAM)

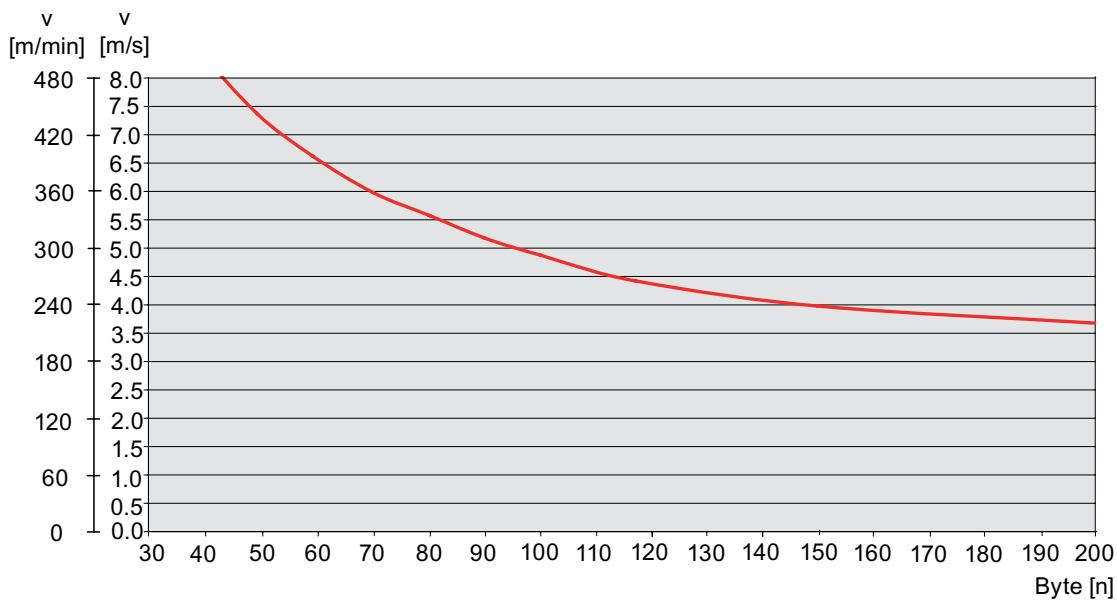

Figure 4-18 Relationship between speed and volume of data (reading/writing FRAM) in dynamic operation when using the RF340R/RF350R with ANT1 and RF370T

RF340R/RF350R with ANT1 and RF380T (FRAM)

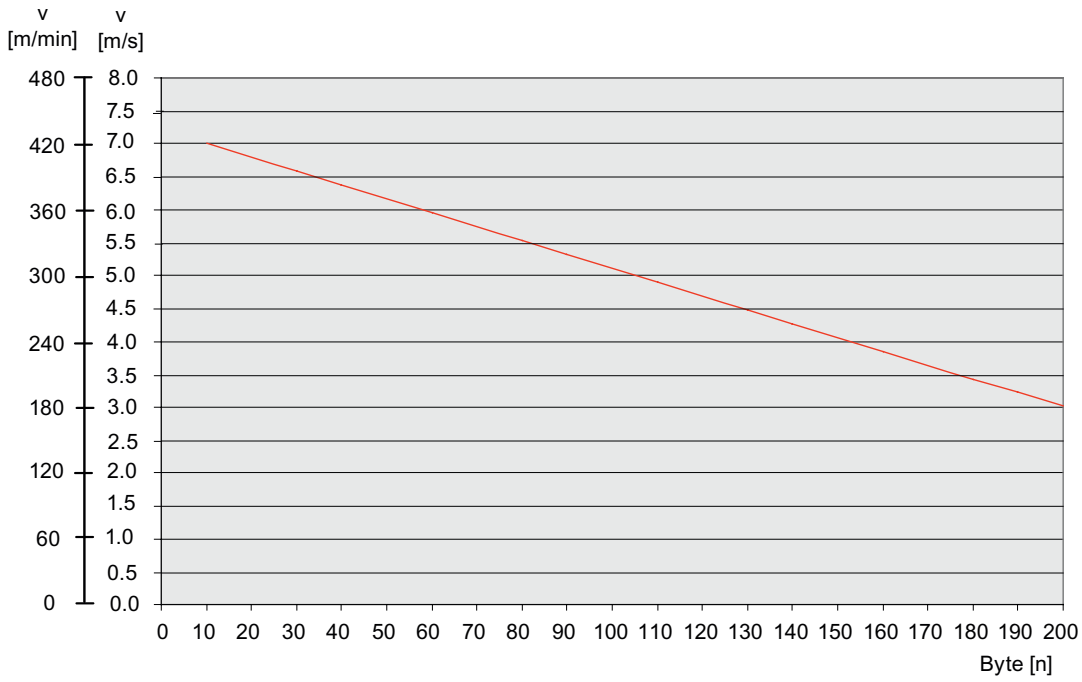

Figure 4-19 Relationship between speed and volume of data (reading/writing FRAM) in dynamic operation when using the RF340R/RF350R with ANT1 and RF380T

4.3.4 RF380R

The curves shown here show the relationship between the speed of the RF320T, RF340T, RF350T, RF360T, RF370T and RF380T transponders and the RF380R reader and the corresponding volume of data.

The following table is used to calculate the curves.

The indicated speeds are applicable for operation without presence check.

	RF320T	RF340T	RF350T	RF360T	RF370T	RF380T
Length of the transmission window (L)	30 mm	38 mm	45 mm	45 mm	70 mm	88 mm
Operating distance (S _a)	40 mm	40 mm	40 mm	60 mm	40 mm	40 mm

RF380R and RF320T/RF340T (EEPROM)

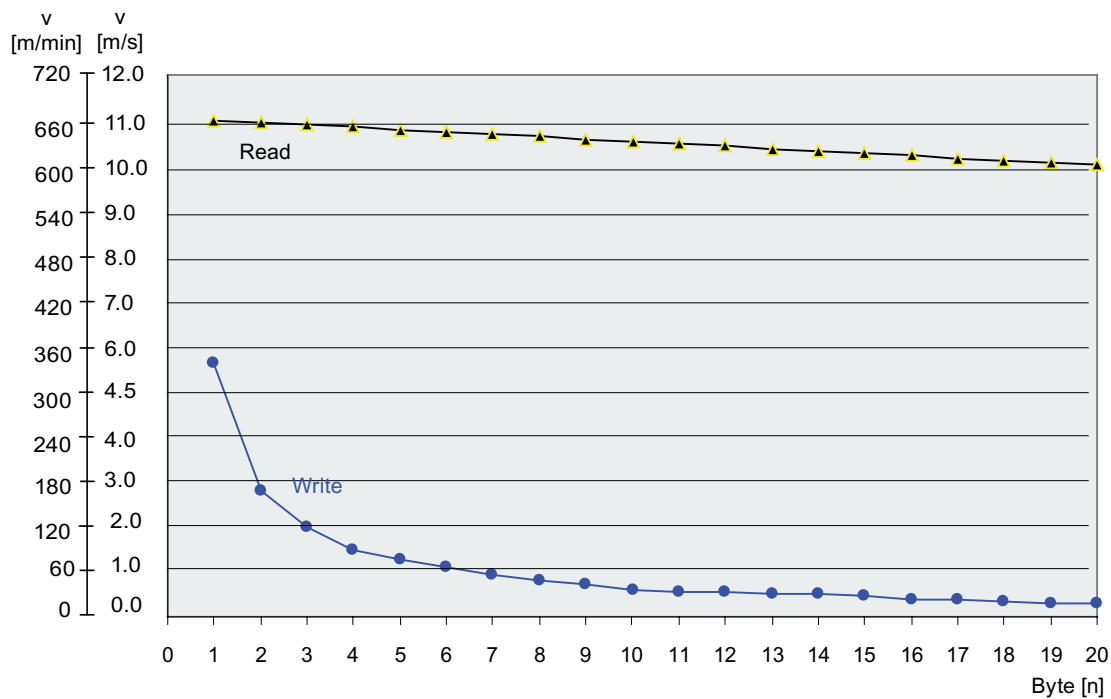

Figure 4-20 Relationship between speed and volume of data (reading/writing from EEPROM) in dynamic operation when using the RF380R and RF320T/RF340T

RF380R and RF340T (FRAM)

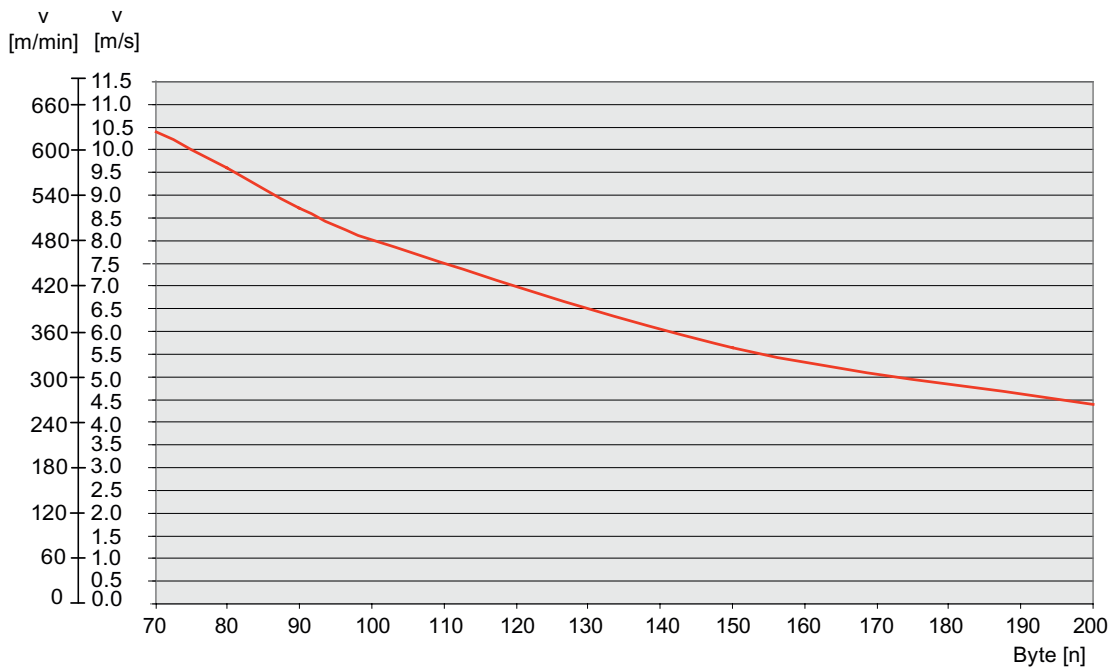

Figure 4-21 Relationship between speed and volume of data (reading/writing FRAM) in dynamic operation when using the RF380R and RF340T

RF380R and RF350T/RF360T (EEPROM)

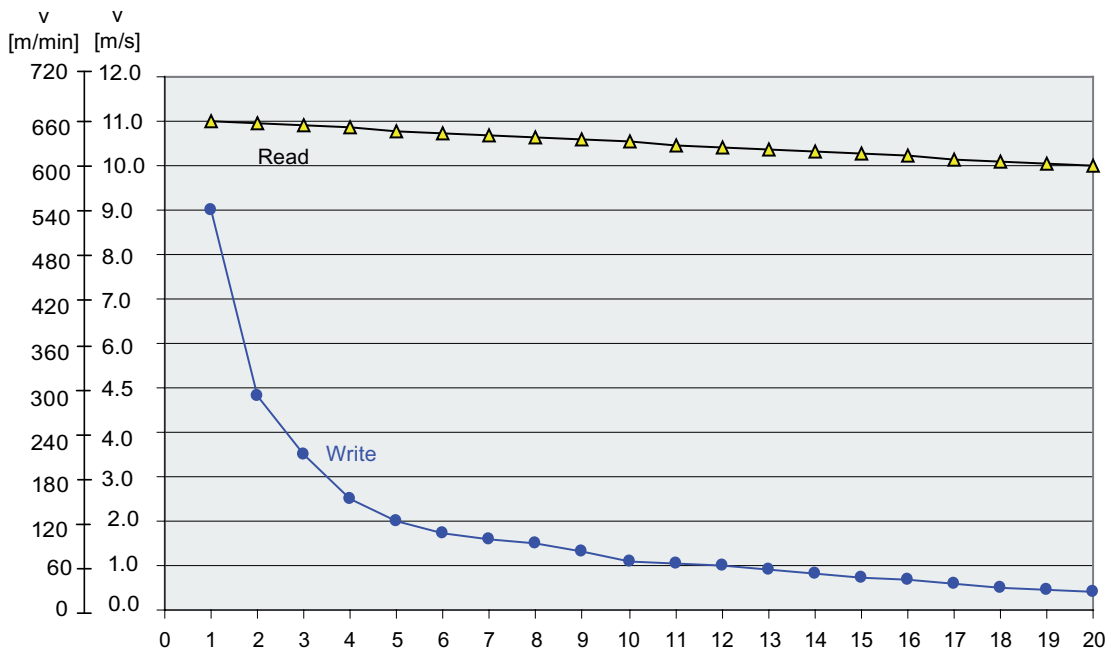

Figure 4-22 Relationship between speed and volume of data (reading/writing EEPROM) in dynamic operation when using the RF380R and RF350T/RF360T

RF380R and RF350T (FRAM)

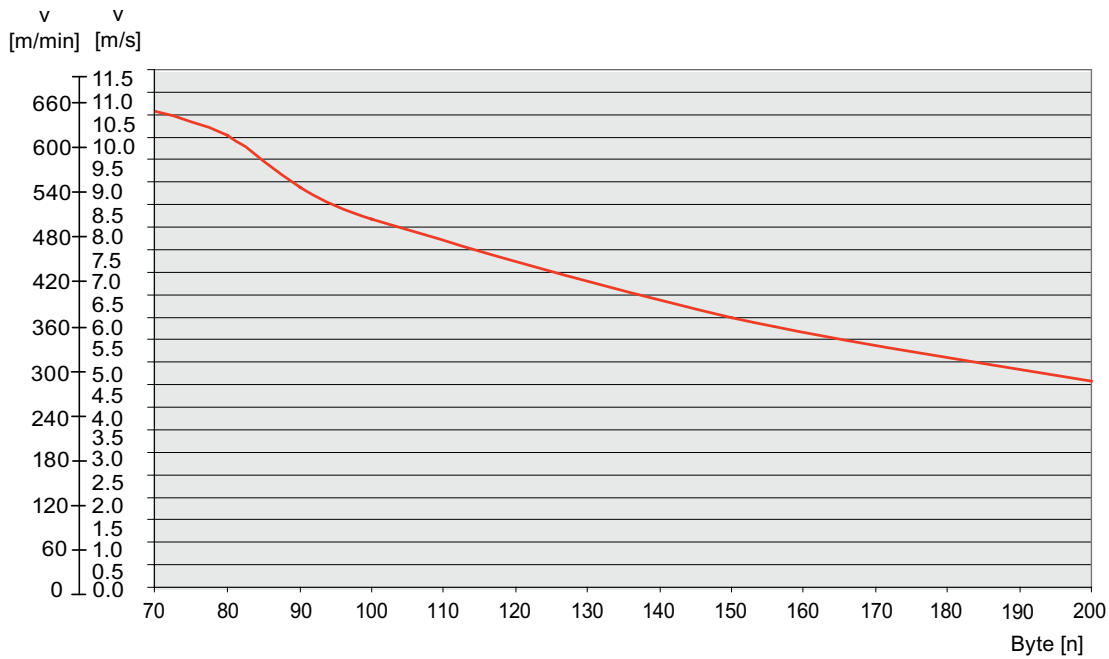

Figure 4-23 Relationship between speed and volume of data (reading/writing FRAM) in dynamic operation when using the RF380R and RF350T

RF380R and RF360T (FRAM)

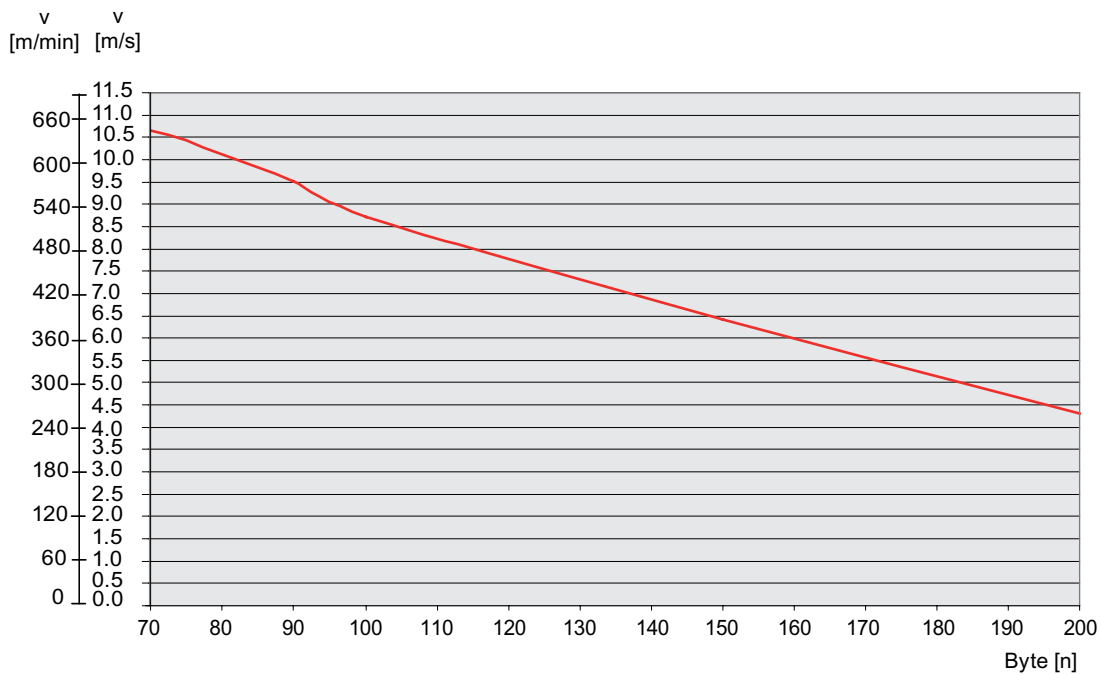

Figure 4-24 Relationship between speed and volume of data (reading/writing FRAM) in dynamic operation when using the RF380R and RF360T

RF380R and RF370T/RF380T (EEPROM)

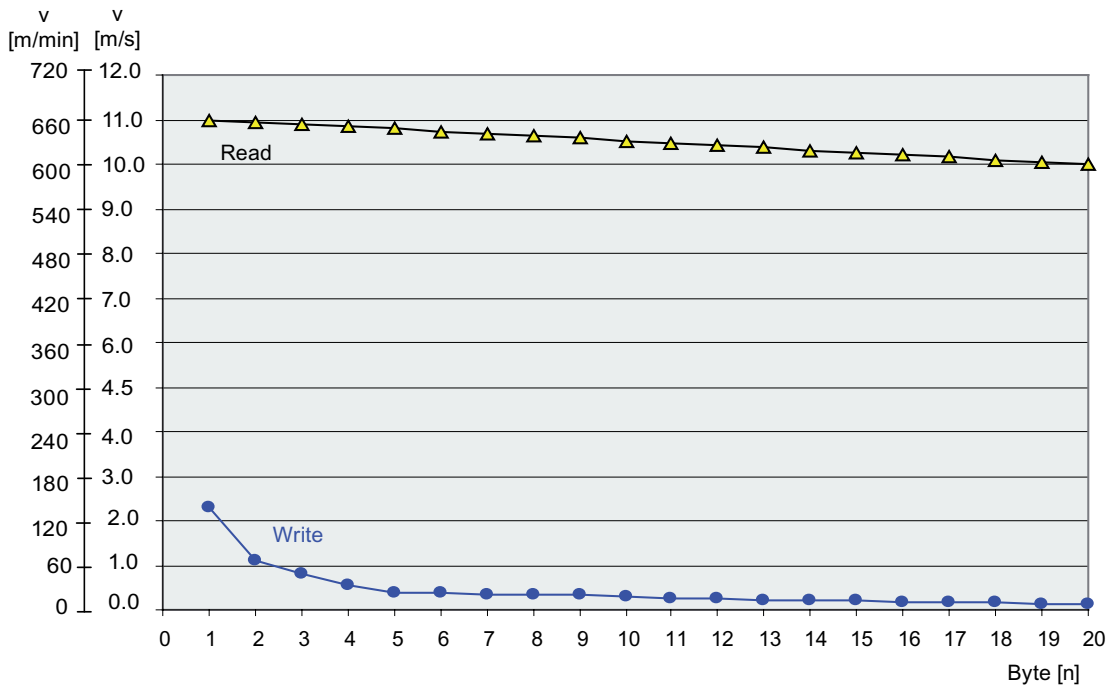

Figure 4-25 Relationship between speed and volume of data (reading/writing from EEPROM) in dynamic operation when using the RF380R and RF370T/RF380T

RF380R and RF370T (FRAM)

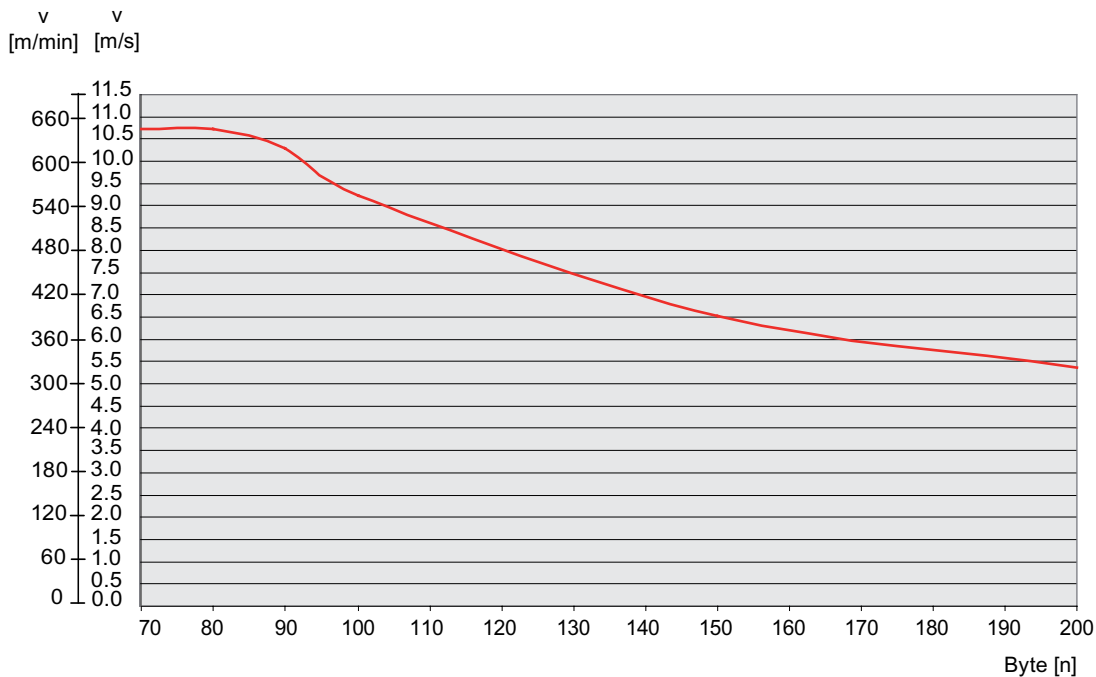

Figure 4-26 Relationship between speed and volume of data (reading/writing FRAM) in dynamic operation when using the RF380R and RF370T

RF380R and RF380T (FRAM)

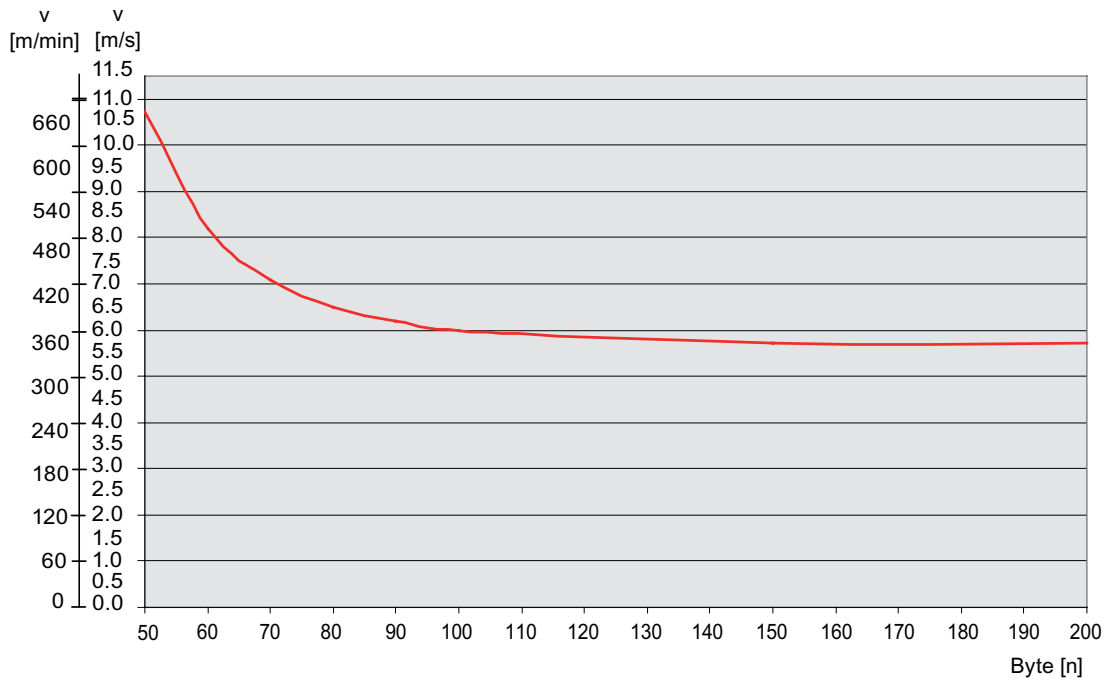

Figure 4-27 Relationship between speed and volume of data (reading/writing FRAM, not present) in dynamic operation when using the RF380R and RF380T

4.4 Installation guidelines

4.4.1 Overview

The transponder and reader complete with their antennas are inductive devices. Any type of metal, in particular iron and ferromagnetic materials, in the vicinity of these devices will affect their operation. Some points need to be considered during planning and installation if the values described in the "Field data" section are to retain their validity:

- Minimum spacing between two readers or their antennas
- Minimum distance between two adjacent data memories
- Metal-free area for flush-mounting of readers or their antennas and transponders in metal
- Mounting of multiple readers or their antennas on metal frames or racks

The following sections describe the impact on the operation of the identification system when mounted in the vicinity of metal.

4.4.2 Reduction of interference due to metal

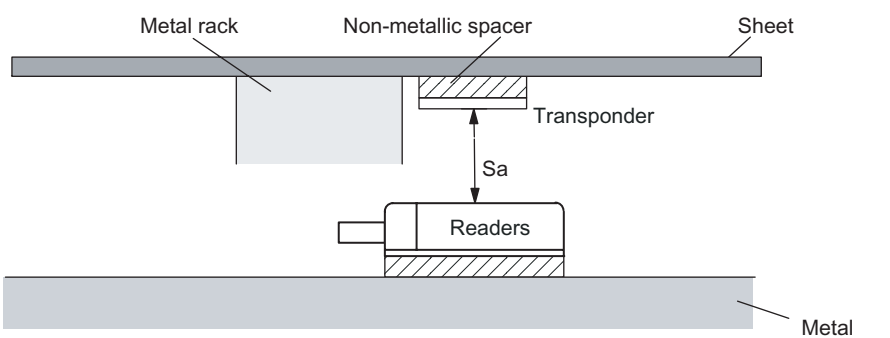
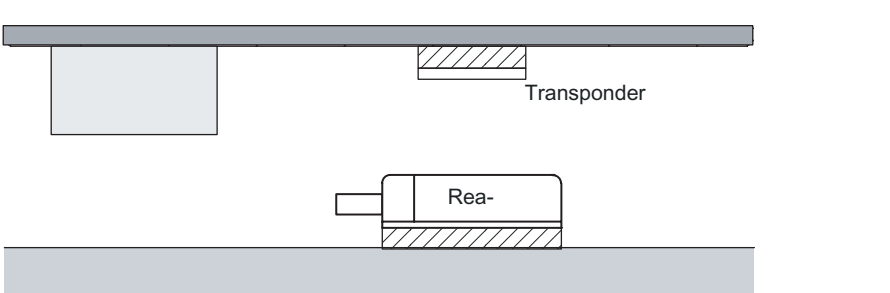
Interference due to metal rack	Problem
 <p>The diagram illustrates a cross-section of the system. At the top, a horizontal bar represents the 'Metal rack'. Below it, a 'Sheet' is shown. A 'Non-metallic spacer' is placed between the metal rack and a 'Transponder'. A 'Readers' unit is positioned below the transponder. A double-headed arrow labeled 'Sa' indicates the distance between the reader and the transponder. The metal rack is also labeled 'Metal'.</p>	<p>A metal rack is located above the transmission window of the reader. This affects the entire field. In particular, the transmission window between reader and transponder is reduced.</p>
 <p>The diagram shows the same setup as the previous one, but the 'Metal rack' is now positioned further to the left, away from the 'Transponder'. The 'Readers' unit is now labeled 'Rea-'. The distance between the reader and the transponder is visibly increased, indicating a larger transmission window.</p>	<p>Remedy: The transmission window is no longer affected if the transponder is mounted differently.</p>

Flush-mounting

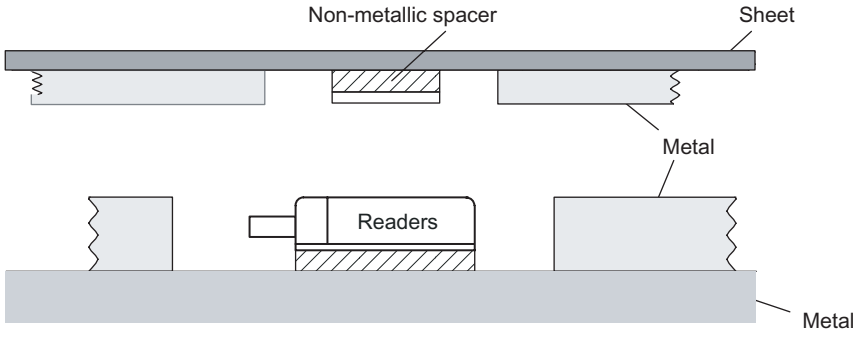
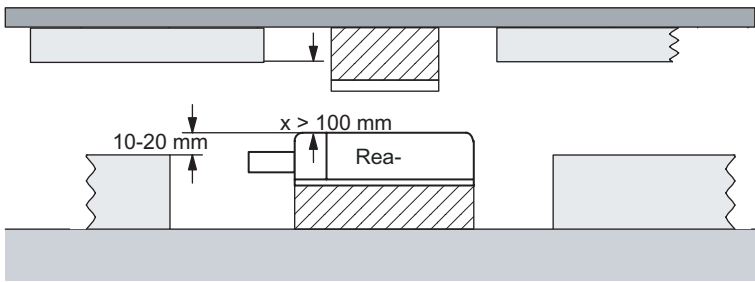
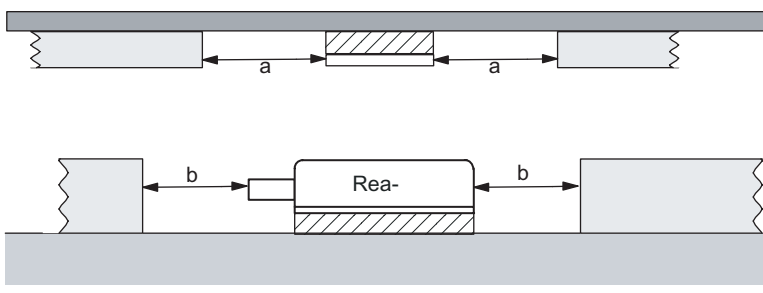
Flush-mounting of transponders and readers	Problem
	<p>Flush-mounting of transponders and readers is possible in principle. However, the size of the transmission window is significantly reduced. The following measures can be used to counteract the reduction of the window:</p>
	<p>Remedy:</p> <p>Enlargement of the non-metallic spacer below the transponder and/or reader.</p> <p>The transponder and/or reader are 10 to 20 mm higher than the metal surround.</p> <p>(The value $x \geq 100$ mm is valid, e.g. for RF310R. It indicates that, for a distance $x \geq 100$ mm, the reader can no longer be significantly affected by metal.)</p>
	<p>Remedy:</p> <p>Increase the non-metallic distance a, b.</p> <p>The following rule of thumb can be used:</p> <ul style="list-style-type: none"> • Increase a, b by a factor of 2 to 3 over the values specified for metal-free areas • Increasing a, b has a greater effect for readers or transponders with a large limit distance than for readers or transponders with a small limit distance.

Mounting of several readers on metal frames or racks

Any reader mounted on metal couples part of the field to the metal frame. There is normally no interaction as long as the minimum distance D and metal-free areas a , b are maintained. However, interaction may take place if an iron frame is positioned unfavorably. Longer data transfer times or sporadic error messages at the communication module are the result.

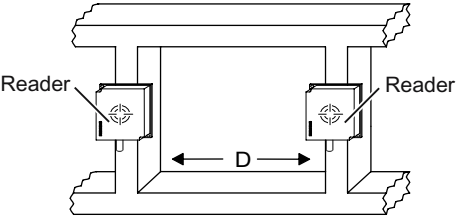
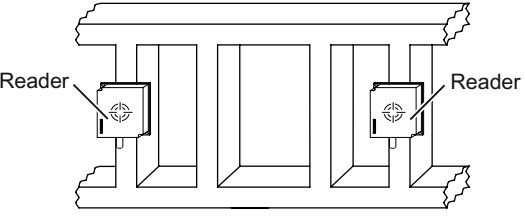
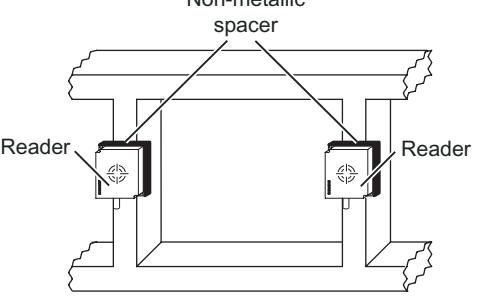
Mounting of several readers on metal racks	Problem: Interaction between readers
 <p>The diagram shows two rectangular readers mounted on a metal rack. A double-headed arrow between the two readers is labeled 'D', representing the distance between them.</p>	<p>Remedy</p> <p>Increase the distance D between the two readers.</p>
 <p>The diagram shows two rectangular readers mounted on a metal rack. Between the two readers, there are three vertical iron struts connecting the top and bottom rails of the rack.</p>	<p>Remedy</p> <p>Introduce one or more iron struts in order to short-circuit the stray fields.</p>
 <p>The diagram shows two rectangular readers mounted on a metal rack. Between each reader and the metal frame, there is a dark rectangular non-metallic spacer. A label 'Non-metallic spacer' with arrows points to these spacers.</p>	<p>Remedy</p> <p>Insert a non-metallic spacer of 20 to 40 millimeter thickness between the reader and the iron frame. This will significantly reduce the induction of stray fields on the rack:</p>

4.4.3 Effects of metal on different transponders and readers

Mounting different transponders and readers on metal or flush-mounting

Certain conditions have to be observed when mounting the transponders and readers on metal or flush-mounting. For more information, please refer to the descriptions of the individual transponders and readers in the relevant section.

4.4.4 Impact on the transmission window by metal

In general, the following points should be considered when mounting RFID components:

- Direct mounting on metal is allowed only in the case of specially approved transponders.
- Flush-mounting of the components in metal reduces the field data; a test is recommended in critical applications.
- When working inside the transmission window, it should be ensured that no metal rail (or similar part) intersects the transmission field.
The metal rail would affect the field data.

The impact of metal on the field data (S_g , S_a , L, B) is shown in tabular format in this section. The values in the table describe the reduction of the field data in % with reference to non-metal (100 % means no impact).

Reduction of field data: Transponder and RF310R reader

Table 4-6 Reduction of field data by metal (in %): Transponder and RF310R

Transponder	Reader RF310R		
	Without metal	on metal	flush-mounted in metal (20 mm surround)
RF320T			
Without metal	100	95	80
On metal; distance 20 mm	100	80	70
Flush-mounted in metal; distance all-round 20 mm	80	70	60
RF340T			
Without metal	100	95	80
on metal	80	80	80
Flush-mounted in metal; distance all-round 20 mm	70	70	70
RF350T			
Without metal	100	95	85
on metal	70	65	65
Flush-mounted in metal; distance all-round 20 mm	60	60	60
RF360T			
Without metal	100	95	85
On metal; distance 20 mm	100	95	75
Flush-mounted in metal; distance all-round 20 mm	60	60	60

Reduction of field data: Transponder and RF340R reader

Table 4-7 Reduction of field data by metal (in %): Transponder and RF340R

Transponder	Reader RF340R		
	Without metal	on metal	flush-mounted in metal (20 mm surround)
RF320T			
Without metal	100	95	80
On metal; distance 20 mm	100	90	75
Flush-mounted in metal; distance all-round 20 mm	80	70	60
RF340T			
Without metal	100	95	85
on metal	80	80	70
Flush-mounted in metal; distance all-round 20 mm	70	70	70
RF350T			
Without metal	100	95	80
on metal	70	65	65
Flush-mounted in metal; distance all-round 20 mm	60	60	60
RF360T			
Without metal	100	95	85
On metal; distance 20 mm	90	90	75
Flush-mounted in metal; distance all-round 20 mm	70	60	60
RF370T			
Without metal	100	98	96
on metal	100	97	94
Flush-mounted in metal; distance all-round 20 mm	90	88	86
RF380T			
Without metal	100	86	76 (all-round 40 mm)
on metal	100	86	76 (all-round 40 mm)
Flush-mounted in metal; distance all-round 40 mm	83	71	55 (all-round 40 mm)

Reduction of field data: Transponder and RF350R reader with ANT1

Table 4-8 Reduction of field data by metal (in %): Transponder and RF350R with ANT1

Transponder	Mounting the antenna		
	Without metal	on metal	flush-mounted in metal (20 mm surround)
RF320T			
Without metal	100	95	80
On metal; distance 20 mm	100	90	75
Flush-mounted in metal; distance all-round 20 mm	80	70	60
RF340T			
Without metal	100	95	85
on metal	80	80	70
Flush-mounted in metal; distance all-round 20 mm	70	70	70
RF350T			
Without metal	100	95	80
on metal	70	65	65
Flush-mounted in metal; distance all-round 20 mm	60	60	60
RF360T			
Without metal	100	95	85
On metal; distance 20 mm	90	90	75
Flush-mounted in metal; distance all-round 20 mm	70	60	60
RF370T			
Without metal	100	86	73
on metal	100	83	69
Flush-mounted in metal; distance all-round 20 mm	90	74	61
RF380T			
Without metal	100	83	73 (all-round 40 mm)
on metal	100	83	73 (all-round 40 mm)
Flush-mounted in metal; distance all-round 40 mm	80	68	53 (all-round 40 mm)

Reduction of field data: Transponder and RF350R reader with ANT18

Table 4-9 Reduction of field data by metal (in %): Transponder and RF350R with ANT18

Transponder	Mounting the antenna	
	Without metal	flush-mounted in metal (10 mm surround; 10 mm deep)
RF320T		
Without metal	100	100
On metal; distance 20 mm	100	100
Flush-mounted in metal; distance all-round 20 mm	80	80
RF340T		
Without metal	100	100
on metal	80	80
Flush-mounted in metal; distance all-round 20 mm	70	70
RF350T		
Without metal	combination not permitted	
on metal		
Flush-mounted in metal; distance all-round 20 mm		
RF360T		
Without metal	combination not permitted	
On metal; distance 20 mm		
Flush-mounted in metal; distance all-round 20 mm		

Reduction of field data: Transponder and RF350R reader with ANT30

Table 4-10 Reduction of field data by metal (in %): Transponder and RF350R with ANT30

Transponder	Mounting the antenna	
	Without metal	flush-mounted in metal (20 mm surround; 20 mm deep)
RF320T		
Without metal	100	80
On metal; distance 20 mm	100	80
Flush-mounted in metal; distance all-round 20 mm	100	80
RF340T		
Without metal	100	80
on metal	80	65
Flush-mounted in metal; distance all-round 20 mm	70	60
RF350T		
Without metal	100	80
on metal	70	60
Flush-mounted in metal; distance all-round 20 mm	65	55
RF360T		
Without metal	combination not permitted	
On metal; distance 20 mm		
Flush-mounted in metal; distance all-round 20 mm		

Reduction of field data: Transponder and RF380R reader

Table 4-11 Reduction of field data by metal (in %): Transponder and RF380R

Transponder	RF380R reader		
	Without metal	on metal	flush-mounted in metal (20 mm surround)
RF320T			
Without metal	100	90	50
On metal; distance 20 mm	85	80	30
Flush-mounted in metal; distance all-round 20 mm	35	30	20
RF340T			
Without metal	100	95	60
on metal	93	90	52
Flush-mounted in metal; distance all-round 20 mm	83	80	45
RF350T			
Without metal	100	95	63
on metal	85	70	57
Flush-mounted in metal; distance all-round 20 mm	70	60	46
RF360T			
Without metal	100	98	60
On metal; distance 20 mm	85	75	70
Flush-mounted in metal; distance all-round 20 mm	55	50	60
RF370T			
Without metal	100	100	92
on metal	90	90	75
Flush-mounted in metal; distance all-round 20 mm	70	65	60
RF380T			
Without metal	100	93	55
on metal	80	75	50
Flush-mounted in metal; distance all-round 40 mm	75	65	40

4.5 Chemical resistance of the transponders

The following table provides an overview of the chemical resistance of the data memories made of glass-fiber-reinforced epoxy resin. It must be emphasized that the plastic enclosure is extremely resistant to chemicals in automobiles (e.g.: oil, grease, diesel fuel, gasoline) which are not listed separately.

Transponders RF320T, RF360T

Transponder RF 320T is resistant to the substances specified in the following table.

	Concentration	20 °C	40 °C	60 °C
Allylchloride		oooo		
Formic acid	50 %	oooo		
	100 %	oo		
Ammonia gas		oooo		
Ammonia liquid, water-free		-		
Ammonium hydroxide	10 %	oooo		
Ethyl acrylate		oooo		
Ethyl glycol				oooo
Gasoline, aroma-free		oooo		
Gasoline, containing benzol		oooo		
Benzoate (Na-, Ca.a.)			oooo	
Benzoic acid		oooo		
Benzole		oooo		
Benzenesulphonic acid		oooo		
Benzyl chloride		-		
Borax				oooo
Boric acid		oooo		
Bromine, liquid		-		
Bromine, gas, dry		-		
Bromide (K-, Na.a.)				oooo
Bromoform	100 %	oooo		
Bromine water		-		
Butadiene (1,3-)		oooo		
Butane gas		oooo		
Butanol		-		
Butyric acid	100 %	oo		
Carbonate (ammonium, Na.a.)				oooo
Chlorine, liquid		-		
Chlorine, gas, dry	100 %	-		
Chlorobenzene		oooo		
Chloride (ammonium, Na.a.)				oooo
Chloroform		-		
Chlorophyl		oooo		
Chlorosulphonic acid	100 %	-		

4.5 Chemical resistance of the transponders

	Concentration	20 °C	40 °C	60 °C
Chlorine water (saturated solution)		oo		
Chromate (K-, Na.a.)	Up to 50 %		oooo	
Chromic acid	Up to 30 %	-		
Chromosulphuric acid		-		
Citric acid		oooo		
Cyanamide		oooo		
Cyanide (K-, Na.a.)				oooo
Dextrin, w.				oooo
Diethyl ether		oooo		
Diethylene glycol				oooo
Dimethyl ether		oooo		
Dioxane		-		
Developer			oooo	
Acetic acid	100 %	oo		
Ethanol			oooo	oooo
Fixer			oooo	
Fluoride (ammonium, K-, Na.a.)			oooo	
Hydrofluoric acid	Up to 40 %	oooo		
Formaldehyde	50 %	oooo		
Formamide	100 %	oooo		
Glucon acid		oooo		
Glycerine				oooo
Glycol				oooo
Urine		oooo		
Uric acid		oooo		
Hydroxide (ammonium)	10 %	oooo		
Hydroxide (Na-, K-)	40 %	oooo		
Hydroxide (alkaline earth metal)				oooo
Hypochlorite (K-, Na.a.)				oooo
Iodide (K-, Na.a.)				oooo
Silicic acid				oooo
Cresol	Up to 90 %	-		
Methanol	100 %		oooo	
Methylene chloride		-		
Lactic acid	100 %	oo		
Mineral oils			oooo	
Nitrate (ammonium, K.a.)				oooo
Nitroglycerine		-		
Oxalic acid		oooo		
Phenol	1 %	oooo		
Phosphate (ammonium, Na.a.)				oooo

	Concentration	20 °C	40 °C	60 °C
Phosphoric acid	50 %			oooo
	85 %	oooo		
Propanol		oooo		
Nitric acid	25 %	-		
Hydrochloric acid	10 %	-		
Brine				-
Sulphur dioxide	100 %	oo		
Carbon disulfide 100 %		-		
Sulphuric acid	40 %	-		
Sulphurous acid		oo		
Soap solution				oooo
Sulfate (ammonium, Na.a.)				oooo
Sulfite (ammonium, Na.a.)				-
Tar, aroma-free				oooo
Turpentine		oooo		
Trichloroethylene		-		
Hydrogen peroxide	30 %	oooo		
Tartaric acid		oooo		

Abbreviations	
oooo	Resistant
ooo	Virtually resistant
oo	Partially resistant
o	Less resistant
-	Not resistant
w.	Aqueous solution
k. g.	Cold saturated

Transponders RF340T, RF350T, 370T

The following table gives an overview of the chemical composition of the data memories made from polyamide 12. The plastic housing has a notably high resistance to chemicals used in automobiles (e.g.: oil, grease, diesel fuel, gasoline) which are not listed separately.

	Concentration	20 °C	60 °C
Battery acid	30	oo	-
Ammonia gas		oooo	oooo
Ammonia, w.	conc.	oooo	oooo
	10	oooo	oooo
Benzol		oooo	ooo
Bleach solution (12.5% effective chlorine)		oo	-
Butane, gas, liquid		oooo	oooo
Butyl acetate (acetic acid butyl ester)		oooo	oooo
n(n)		oooo	ooo
Calcium chloride, w.		oooo	ooo
Calcium nitrate, w.	k. g.	oooo	ooo
Chlorine		-	-
Chrome baths, tech.		-	-
Iron salts, w.	k. g.	oooo	oooo
Acetic acid, w.	50	-	-
Ethyl alcohol, w., undenaturated	96	oooo	ooo
	50	oooo	oooo
Formaldehyde, w.	30	ooo	-
	10	oooo	ooo
Formalin		ooo	-
Glycerine		oooo	oooo
Isopropanol		oooo	ooo
Potassium hydroxide, w.	50	oooo	oooo
Lysol		oo	-
Magnesium salts, w.	k. g.	oooo	oooo
Methyl alcohol, w.	50	oooo	oooo
Lactic acid, w.	50	oo	-
	10	ooo	oo
Sodium carbonate, w. (soda)	k. g.	oooo	oooo
Sodium chloride, w.	k. g.	oooo	oooo
Sodium hydroxide		oooo	oooo
Nickel salts, w.	k. g.	oooo	oooo
Nitrobenzol		ooo	oo
Phosphoric acid	10	o	V
Propane		oooo	oooo
Mercury		oooo	oooo
Nitric acid	10	o	-
Hydrochloric acid	10	o	-
Sulphur dioxide	Low	oooo	oooo

	Concentration	20 °C	60 °C
Sulphuric acid	25	oo	-
	10	ooo	-
Hydrogen sulphide	Low	oooo	oooo
Carbon tetrachloride		oooo	oooo
Toluene		oooo	ooo
Detergent	High	oooo	oooo
Plasticizer		oooo	oooo

Abbreviations	
oooo	Resistant
ooo	Virtually resistant
oo	Partially resistant
o	Less resistant
-	Not resistant
w.	Aqueous solution
k. g.	Cold saturated

Transponder RF380T

The housing of the heat-resistant data storage unit is made of polyphenylene sulfide (PPS). The chemical resistance of the data storage unit is excellent. No solvent is known that can dissolve the plastic at temperatures below 200 °C. A reduction in the mechanical properties has been observed in aqueous solutions of hydrochloric acid (HCl) and nitric acid (HNO₃) at 80 °C. The excellent resistance to all fuel types including methanol is a particular characteristic. The following table provides an overview of the chemicals investigated.

Substance	Test conditions		Evaluation
	Time[days]	Temperature[°C]	
Acetone	180	55	+
n-Butanol (butyl alcohol)	180	80	+
Butanon-2 (methyl ethyl ketone)	180	60	+
n-butyl acetate	180	80	+
Brake fluid	40	80	+
Calcium chloride (saturated)	40	80	+
Diesel fuel	180	80	+
Diethyl ether	40	23	+
Frigen 113	40	23	+
Anti-freeze	180	120	+
Kerosine	40	60	+
Methanol	180	60	+
Engine oil	40	80	+
Sodium chloride (saturated)	40	80	+
Sodium hydroxide (30%)	180	80	+
Sodium hypochlorite (5%)	30	80	/
	180	80	-
Caustic soda (30%)	40	93	+
Nitric acid (10%)	40	23	+
Hydrochloric acid (10%)	40	80	-
Sulphuric acid (10%)	40	23	+
		(10%)	40
		(30%)	40
Tested fuels:	40	80	+
(FAM-DIN 51 604-A)	180	80	/
Toluene			
1, 1, 1-trichloroethane	180	80	+
Xylene			
Zinc chloride (saturated)	180	80	/
	180	75	+
	180	80	+
	40	80	+

		Test conditions	
Assessment:			
+		Resistant, weight gain < 3 % or weight loss < 0.5 % and/or reduction in fracture resistance < 15 %	
/		Partially resistant, weight gain 3 to 8 % or weight loss 0.5 to 3 % and/or reduction in fracture resistance 15 to 30 %	
-		Not resistant, weight gain > 8 % or weight loss > 3 % and/or reduction in fracture resistance > 30 %	

4.6 EMC Directives

4.6.1 Overview

These EMC Guidelines answer the following questions:

- Why are EMC guidelines necessary?
- What types of external interference have an impact on the system?
- How can interference be prevented?
- How can interference be eliminated?
- Which standards relate to EMC?
- Examples of interference-free plant design

The description is intended for "qualified personnel":

- Project engineers and planners who plan system configurations with RFID modules and have to observe the necessary guidelines.
- Fitters and service engineers who install the connecting cables in accordance with this description or who rectify defects in this area in the event of interference.

NOTICE

Failure to observe notices drawn to the reader's attention can result in dangerous conditions in the plant or the destruction of individual components or the entire plant.

4.6.2 What does EMC mean?

The increasing use of electrical and electronic devices is accompanied by:

- Higher component density
- More switched power electronics
- Increasing switching rates
- Lower power consumption of components due to steeper switching edges

The higher the degree of automation, the greater the risk of interaction between devices.

Electromagnetic compatibility (EMC) is the ability of an electrical or electronic device to operate satisfactorily in an electromagnetic environment without affecting or interfering with the environment over and above certain limits.

EMC can be broken down into three different areas:

- Intrinsic immunity to interference:
immunity to internal electrical disturbance
- Immunity to external interference:
immunity to external electromagnetic disturbance
- Degree of interference emission:
emission of interference and its effect on the electrical environment

All three areas are considered when testing an electrical device.

The RFID modules are tested for conformity with the limit values required by the CE and RTTE guidelines. Since the RFID modules are merely components of an overall system, and sources of interference can arise as a result of combining different components, certain guidelines have to be followed when setting up a plant.

EMC measures usually consist of a complete package of measures, all of which need to be implemented in order to ensure that the plant is immune to interference.

Note

The plant manufacturer is responsible for the observance of the EMC guidelines; the plant operator is responsible for radio interference suppression in the overall plant.

All measures taken when setting up the plant prevent expensive retrospective modifications and interference suppression measures.

The plant operator must comply with the locally applicable laws and regulations. They are not covered in this document.

4.6.3 Basic rules

It is often sufficient to follow a few elementary rules in order to ensure electromagnetic compatibility (EMC).

The following rules must be observed:

Shielding by enclosure

- Protect the device against external interference by installing it in a cabinet or housing. The housing or enclosure must be connected to the chassis ground.
- Use metal plates to shield against electromagnetic fields generated by inductances.
- Use metal connector housings to shield data conductors.

Wide-area ground connection

- Bond all passive metal parts to chassis ground, ensuring large-area and low-HF-impedance contact.
- Establish a large-area connection between the passive metal parts and the central grounding point.
- Don't forget to include the shielding bus in the chassis ground system. That means the actual shielding busbars must be connected to ground by large-area contact.
- Aluminium parts are not suitable for ground connections.

Plan the cable installation

- Break the cabling down into cable groups and install these separately.
- Always route power cables, signal cables and HF cables through separated ducts or in separate bundles.
- Feed the cabling into the cabinet from one side only and, if possible, on one level only.
- Route the signal cables as close as possible to chassis surfaces.
- Twist the feed and return conductors of separately installed cables.
- Routing HF cables:
avoid parallel routing of HF cables.
- Do not route cables through the antenna field.

Shielding for the cables

- Shield the data cables and connect the shield at both ends.
- Shield the analog cables and connect the shield at one end, e.g. on the drive unit.
- Always apply large-area connections between the cable shields and the shielding bus at the cabinet inlet and make the contact with clamps.
- Feed the connected shield through to the module without interruption.
- Use braided shields, not foil shields.

Line and signal filter

- Use only line filters with metal housings
- Connect the filter housing to the cabinet chassis using a large-area low-HF-impedance connection.
- Never fix the filter housing to a painted surface.
- Fix the filter at the control cabinet inlet or in the direction of the source.

4.6.4 Propagation of electromagnetic interference

Three components have to be present for interference to occur in a system:

- Interference source
- Coupling path
- Interference sink

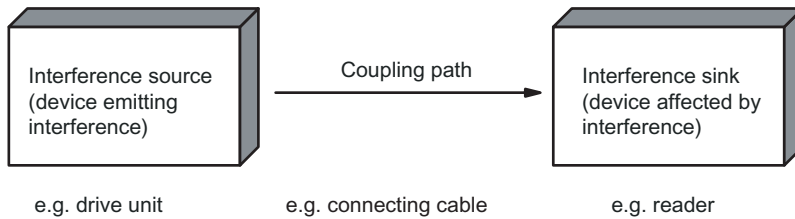

Figure 4-28 Propagation of interference

If one of the components is missing, e.g. the coupling path between the interference source and the interference sink, the interference sink is unaffected, even if the interference source is transmitting a high level of noise.

The EMC measures are applied to all three components, in order to prevent malfunctions due to interference. When setting up a plant, the manufacturer must take all possible measures in order to prevent the occurrence of interference sources:

- Only devices fulfilling limit class A of VDE 0871 may be used in a plant.
- Interference suppression measures must be introduced on all interference-emitting devices. This includes all coils and windings.
- The design of the system must be such that mutual interference between individual components is precluded or kept as small as possible.

Information and tips for plant design are given in the following sections.

Interference sources

In order to achieve a high level of electromagnetic compatibility and thus a very low level of disturbance in a plant, it is necessary to recognize the most frequent interference sources. These must then be eliminated by appropriate measures.

Table 4-12 Interference sources: origin and effect

Interference source	Interference results from	Effect on the interference sink
Contactors, electronic valves	Contacts	System disturbances
	Coils	Magnetic field
Electrical motor	Collector	Electrical field
	Winding	Magnetic field
Electric welding device	Contacts	Electrical field
	Transformer	Magnetic field, system disturbance, transient currents
Power supply unit, switched-mode	Circuit	Electrical and magnetic field, system disturbance
High-frequency appliances	Circuit	Electromagnetic field
Transmitter (e.g. service radio)	Antenna	Electromagnetic field
Ground or reference potential difference	Voltage difference	Transient currents
Operator	Static charge	Electrical discharge currents, electrical field
Power cable	Current flow	Electrical and magnetic field, system disturbance
High-voltage cable	Voltage difference	Electrical field

What interference can affect RFID?

Interference source	Cause	Remedy
Switched-mode power supply	Interference emitted from the current infeed	Replace the power supply
Interference injected through the cables connected in series	Cable is inadequately shielded	Better cable shielding
	The reader is not connected to ground.	Ground the reader
HF interference over the antennas	caused by another reader	<ul style="list-style-type: none"> • Position the antennas further apart. • Erect suitable damping materials between the antennas. • Reduce the power of the readers. Please follow the instructions in the section <i>Installation guidelines/reducing the effects of metal</i>

Coupling paths

A coupling path has to be present before the disturbance emitted by the interference source can affect the system. There are four ways in which interference can be coupled in:

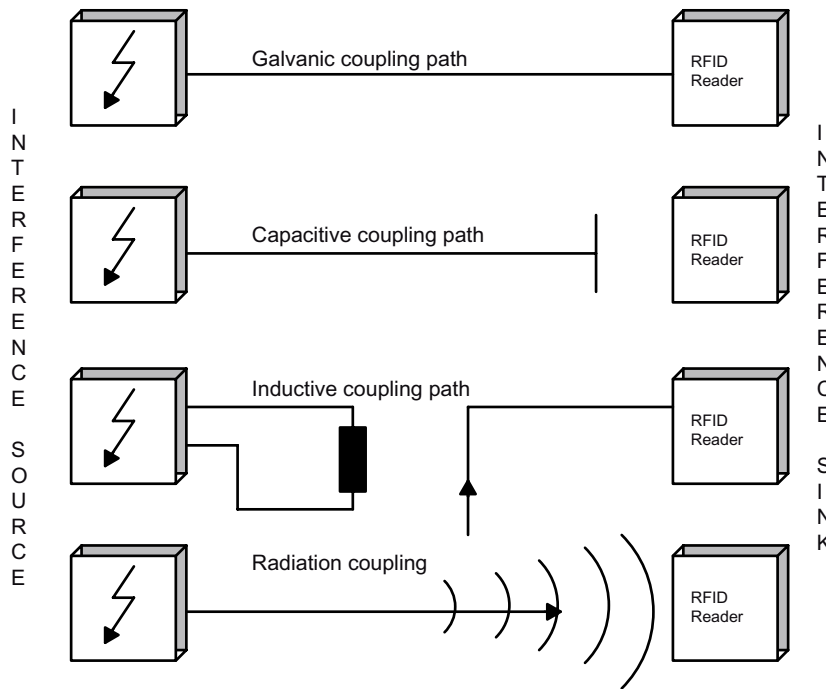

Figure 4-29 Ways in which interference can be coupled in

When RFID modules are used, different components in the overall system can act as a coupling path:

Table 4-13 Causes of coupling paths

Coupling path	Invoked by
Conductors and cables	<ul style="list-style-type: none"> • Incorrect or inappropriate installation • Missing or incorrectly connected shield • Inappropriate physical arrangement of cables
Control cabinet or housing	<ul style="list-style-type: none"> • Missing or incorrectly wired equalizing conductor • Missing or incorrect earthing • Inappropriate physical arrangement • Components not mounted securely • Unfavorable cabinet configuration

4.6.5 Cabinet configuration

The influence of the user in the configuration of an electromagnetically compatible plant encompasses cabinet configuration, cable installation, ground connections and correct shielding of cables.

Note

For information about electromagnetically compatible cabinet configuration, please consult the installation guidelines for SIMATIC PLCs.

Shielding by enclosure

Magnetic and electrical fields and electromagnetic waves can be kept away from the interference sink by using a metal enclosure. The easier the induced interference current can flow, the greater the intrinsic weakening of the interference field. All enclosures and metal panels in the cabinet should therefore be connected in a manner allowing good conductance.

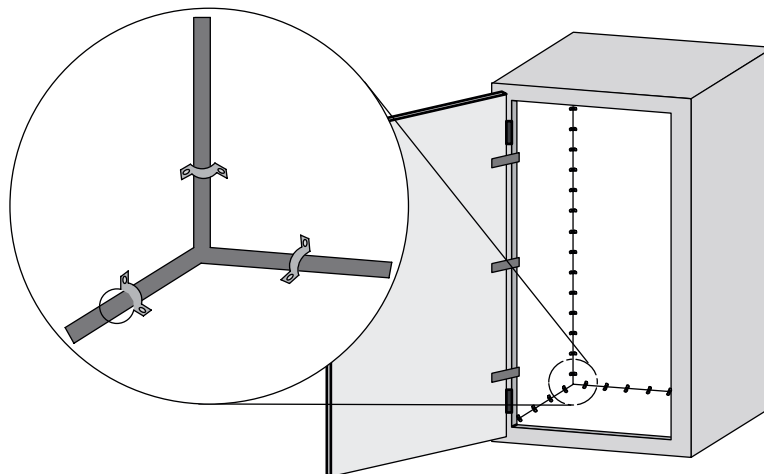

Figure 4-30 Shielding by enclosure

If the control cabinet panels are insulated from each other, a high-frequency-conducting connection can be established using ribbon cables and high-frequency terminals or HF conducting paste. The larger the area of the connection, the greater the high-frequency conductivity. This is not possible using single-wire connections.

Prevention of interference by optimum configuration

Good interference suppression can be achieved by installing SIMATIC PLCs on conducting mounting plates (unpainted). When setting up the control cabinet, interference can be prevented easily by observing certain guidelines. Power components (transformers, drive units, load power supply units) should be arranged separately from the control components (relay control unit, SIMATIC S7).

As a rule:

- The effect of the interference decreases as the distance between the interference source and interference sink increases.
- The interference can be further decreased by installing grounded shielding plates.
- The load connections and power cables should be installed separately from the signal cables with a minimum clearance of 10 cm.

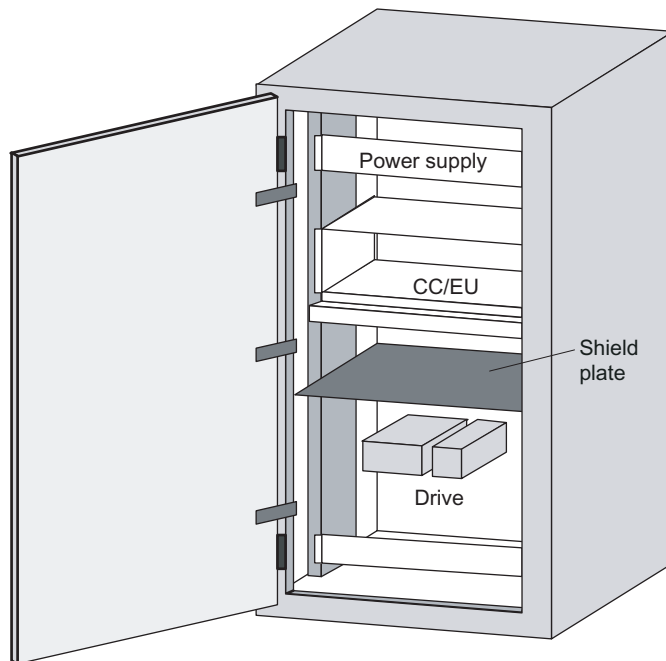

Figure 4-31 Prevention of interference by optimum configuration

Filtering of the supply voltage

External interference from the mains can be prevented by installing line filters. Correct installation is extremely important, in addition to appropriate dimensioning. It is essential that the line filter is mounted directly at the cabinet inlet. As a result, interference is filtered promptly at the inlet, and is not conducted through the cabinet.

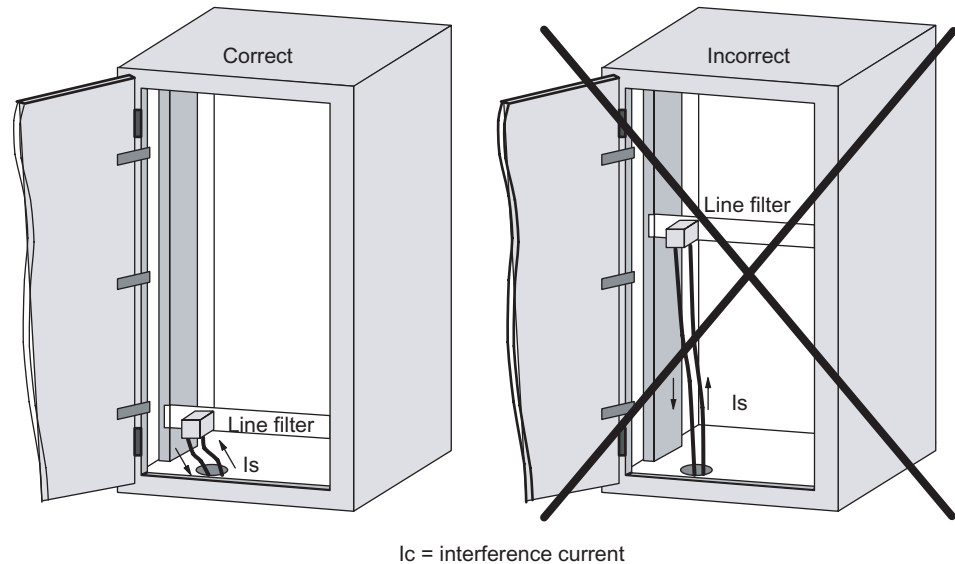

Figure 4-32 Filtering of the supply voltage

4.6.6 Prevention of interference sources

A high level of immunity to interference can be achieved by avoiding interference sources. All switched inductances are frequent sources of interference in plants.

Suppression of inductance

Relays, contactors, etc. generate interference voltages and must therefore be suppressed using one of the circuits below.

Even with small relays, interference voltages of up to 800 V occur on 24 V coils, and interference voltages of several kV occur on 230 V coils when the coil is switched. The use of freewheeling diodes or RC circuits prevents interference voltages and thus stray interference on conductors installed parallel to the coil conductor.

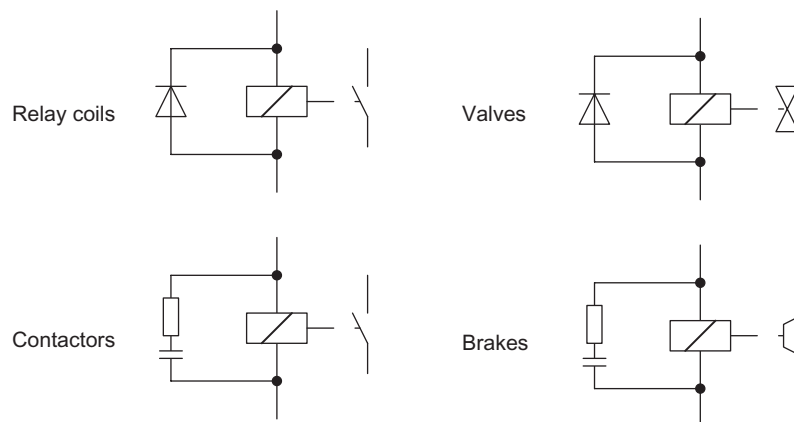

Figure 4-33 Suppression of inductance

Note

All coils in the cabinet should be suppressed. The valves and motor brakes are frequently forgotten. Fluorescent lamps in the control cabinet should be tested in particular.

4.6.7 Equipotential bonding

Potential differences between different parts of a plant can arise due to the different design of the plant components and different voltage levels. If the plant components are connected across signal cables, transient currents flow across the signal cables. These transient currents can corrupt the signals.

Proper equipotential bonding is thus essential.

- The equipotential bonding conductor must have a sufficiently large cross section (at least 10 mm²).
- The distance between the signal cable and the associated equipotential bonding conductor must be as small as possible (antenna effect).
- A fine-strand conductor must be used (better high-frequency conductivity).
- When connecting the equipotential bonding conductors to the centralized equipotential bonding strip (EBS), the power components and non-power components must be combined.
- The equipotential bonding conductors of the separate modules must lead directly to the equipotential bonding strip.

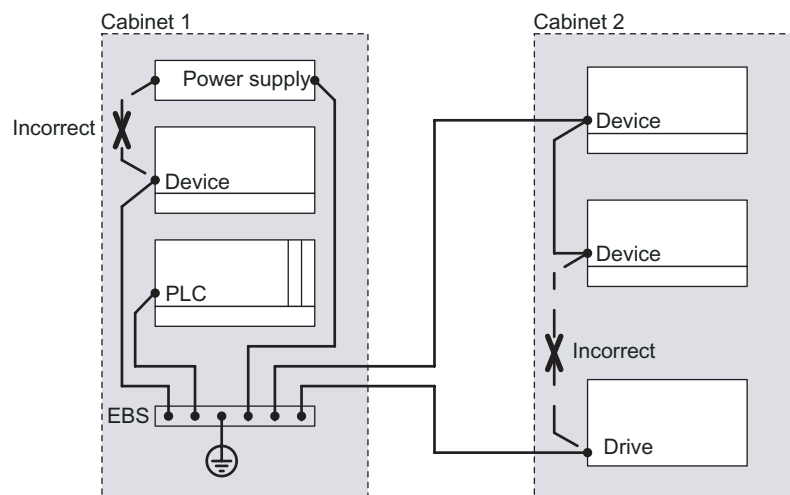

Figure 4-34 Equipotential bonding (EBS = Equipotential bonding strip)

The better the equipotential bonding in a plant, the smaller the chance of interference due to fluctuations in potential.

Equipotential bonding should not be confused with protective earthing of a plant. Protective earthing prevents the occurrence of excessive shock voltages in the event of equipment faults whereas equipotential bonding prevents the occurrence of differences in potential.

4.6.8 Cable shielding

Signal cables must be shielded in order to prevent coupling of interference.

The best shielding is achieved by installing the cables in steel tubes. However, this is only necessary if the signal cable is routed through an environment prone to particular interference. It is usually adequate to use cables with braided shields. In either case, however, correct connection is vital for effective shielding.

Note

An unconnected or incorrectly connected shield has no shielding effect.

As a rule:

- For analog signal cables, the shield should be connected at one end on the receiver side
- For digital signals, the shield should be connected to the enclosure at both ends
- Since interference signals are frequently within the HF range (> 10 kHz), a large-area HF-proof shield contact is necessary

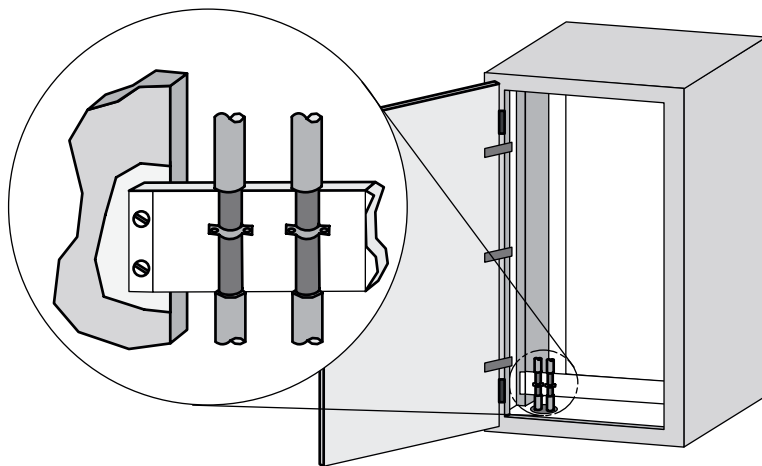

Figure 4-35 Cable shielding

The shielding bus should be connected to the control cabinet enclosure in a manner allowing good conductance (large-area contact) and must be situated as close as possible to the cable inlet. The cable insulation must be removed and the cable clamped to the shielding bus (high-frequency clamp) or secured using cable ties. Care should be taken to ensure that the connection allows good conductance.

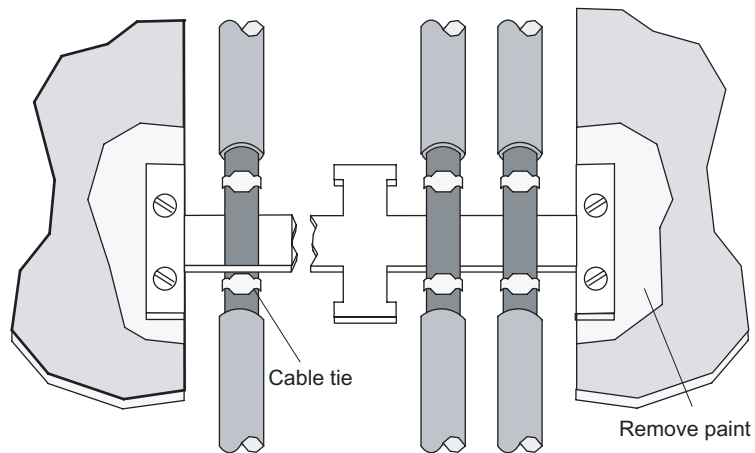

Figure 4-36 Connection of shielding bus

The shielding bus must be connected to the PE busbar.

If shielded cables have to be interrupted, the shield must be continued via the corresponding connector housing. Only suitable connectors may be used for this purpose.

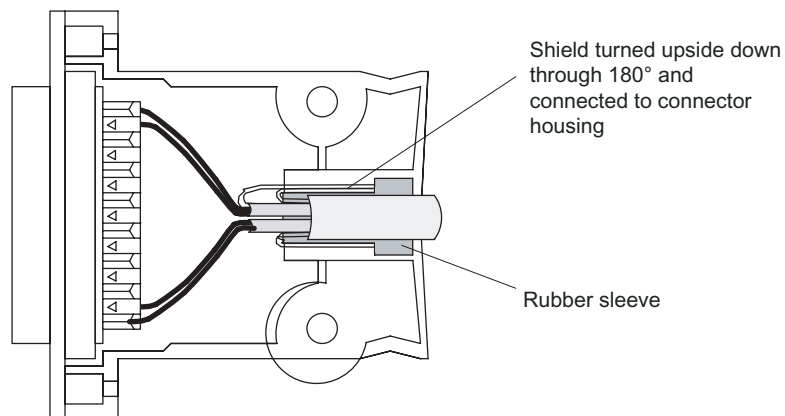

Figure 4-37 Interruption of shielded cables

If intermediate connectors, which do not have a suitable shield connection, are used, the shield must be continued by fixing cable clamps at the point of interruption. This ensures a large-area, HF-conducting contact.

Readers

5.1 Overview

The reader ensures inductive communication with the transponders, and handles the serial connection to the communication modules/interface modules and 8xIQ-Sense module.

Communication between the transponder and reader takes place over inductive alternating fields.

The transmittable data volume between reader and transponder depends on:

- the speed at which the transponder moves through the transmission window of the reader.
- the length of the transmission window.
- the transponder type (FRAM, EEPROM).

5.2 RF310R with IQ-Sense interface

5.2.1 Features

Reader RF310R	Features	
	Structure	① IQ-Sense interface ② Status display
	Application	Identification tasks on small assembly lines in harsh industrial environments
	Read/write distance to transponder	max. 30 mm
	Data transmission rate	<ul style="list-style-type: none"> • Read: approx. 50 byte/s • Write: approx. 40 byte/s

5.2.2 Pin assignment of RF310R IQ-Sense interface

Table 5-1 Pin assignment of RF310R with IQ-Sense interface

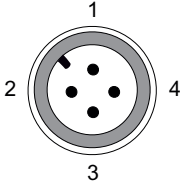
Pin	Pin, device end, 4-pin M12	Assignment
	1	IQ-Sense
	2	Not assigned
	3	IQ-Sense
	4	Not connected

5.2.3 Display elements of the RF310R reader with IQ-Sense interface

Color	Meaning
Green	Operating voltage available
yellow	Transponder present
Red	Error occurred (see FC35 documentation, Section "Error messages and troubleshooting", Subsection "Error messages, error_MOBY")

5.2.4 Ensuring reliable data exchange

The "center point" of the transponder must be situated within the transmission window.

5.2.5 Metal-free area

The RF310R can be flush-mounted in metal. Please allow for a possible reduction in the field data values.

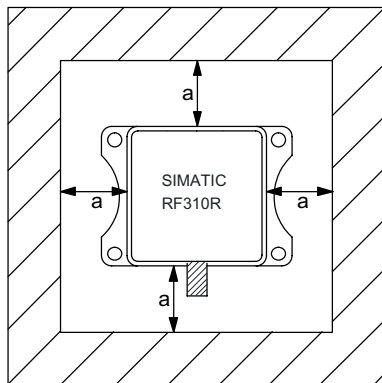

Figure 5-1 Metal-free area for RF310R

To avoid any impact on the field data, the distance a should be ≥ 20 mm.

5.2.6 Minimum distance between RF310R readers

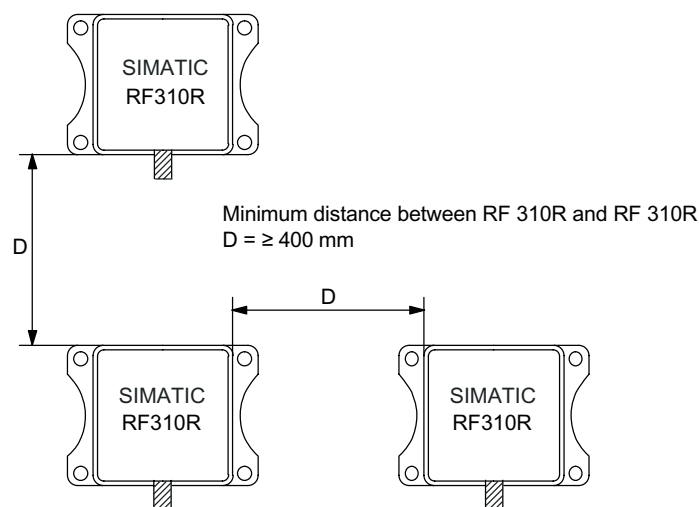

Figure 5-2 Minimum distance between RF310R readers

5.2.7 Technical data for RF310R reader with IQ-Sense interface

Table 5-2 Technical specifications for RF310R reader with IQ-Sense interface

Inductive interface to the transponder	
Transmission frequency for power/data	13.56 MHz
Interface to SIMATIC S7-300	IQ-Sense, 2-wire non-polarized
Required master module	8-IQ-Sense (6ES7 338-7XF00-0AB0)
RFID channels (RF310R)	max. 2 per master module,
Mixed operation with other profiles	max. 4 Opto-BEROs, 1x SIMATIC RF310R
Cable length between reader and communication module	Max. 50 m (unshielded cable)
Write/read distances of reader	See RF310R field data
Minimum distance between two RF310R readers	≥ 400 mm
Data transfer rate for read/write device	
Reading	Approx. 50 byte/s
Writing	Approx. 40 byte/s
Passing speed	
Reading	Approx. 0.8 m/s (2 bytes)
Writing	Approx. 0.8 m/s (2 bytes)
Function	Read, write, initialize transponder
Multi-tag	no
Power supply	via IQ-Sense master module 24 V DC
Display elements	2-color LED (operating voltage, presence, error)
Plug connector	M12 (4-pin)
Enclosure	
Dimensions (in mm)	55 x 75 x 30 (without M12 enclosure connector)
Color	Anthracite
Material	Plastic PA 12
Fixing	4 x M5 screws
Ambient temperature	
during operations	-25°C to +70°C
during transport and storage	-40°C to +85°C
Degree of protection to EN 60529	IP67
Shock to EN 60 721-3-7 Class 7 M2	50 g
Vibration to EN 60 721-3-7 Class 7M2	20 g
Weight	Approx. 200 g
MTBF (Mean Time Between Failures) in years	153,5
Approvals	Radio to R&TTE guidelines EN 300 330, EN 301 489, CE, FCC, UL/CSA
Current consumption	typ. 40 mA

5.2.8 FCC information

Siemens SIMATIC RF300 with IQ-Sense interface

FCC ID: NXW-RF310R-IQ

This device complies with Part 15 of the FCC Rules. Operation is subject to the following two conditions:

- (1) This device may not cause harmful interference.
- (2) This device must accept any interference received, including interference that may cause undesired operation.

Caution

Any changes or modifications not expressly approved by the party responsible for compliance could void the user's authority to operate the equipment.

5.2.9 Ordering data of RF310R with IQ-Sense interface

RF310R	Order No.
With IQ-Sense interface IP67, -25 to +70 °C, 71 x 75 x 30 (L x W x H in mm), with integrated antenna, max. limit distance: 30 mm (depending on transponder)	6GT2801-0AA00

5.2.10 Dimension drawing

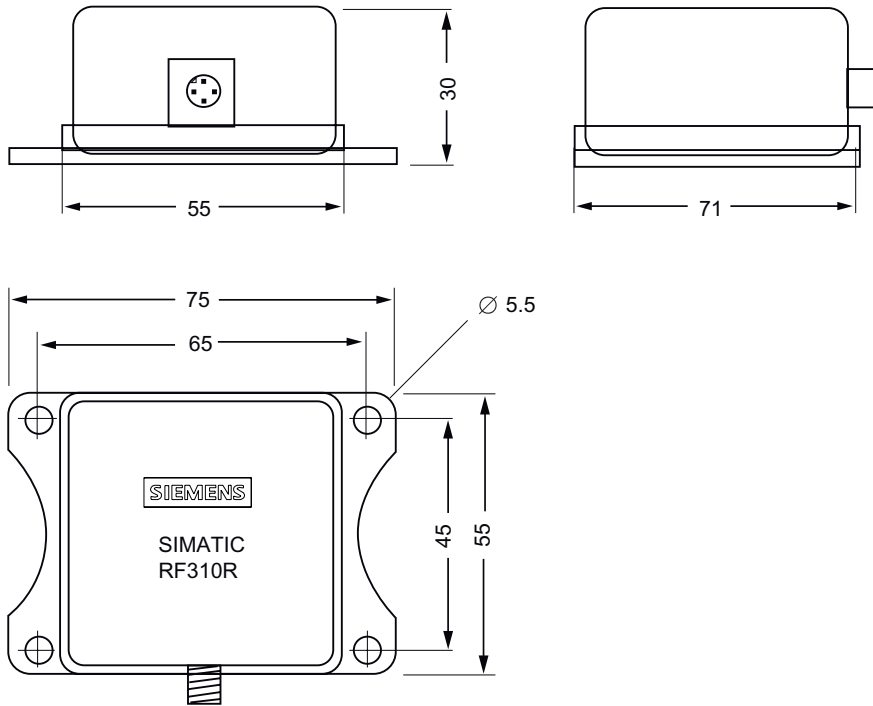

Figure 5-3 Dimension drawing for RF310R

Dimensions in mm