



SENTON

Choose certainty.  
Add value.

22 October 2009

## Prüfbericht / Test Report

Nr. / No. 19201-00707-3 (Edition 1)

Applicant: Siemens AG  
Type of equipment: RFID Reader  
Type designation: RF350R  
Order No.: N/A  
Test standards: FCC Code of Federal Regulations,  
CFR 47, Part 15,  
Sections 15.205, 15.207, 15.215 and 15.225  
  
Industry Canada Radio Standards Specifications  
RSS-Gen Issue 2, Section 7.2.2 and  
RSS-210 Issue 7, Sections 2.2, 2.6, A2.6 (Category I Equipment)

**Note:**

The test data of this report is related only to the individual item which has been tested. This report shall not be reproduced except in full extent without the written approval of the testing laboratory.

## Table of Contents

1	Description of the Equipment Under Test (EUT) .....	3
2	Administrative Data .....	5
3	Identification of the Test Laboratory .....	6
4	Summary .....	7
5	Operation Mode and Configuration of EUT .....	8
6	Measurement Procedures .....	9
6.1	Conducted Output Power .....	9
6.2	Bandwidth Measurements .....	11
6.3	Conducted AC Powerline Emission .....	13
6.4	Radiated Emission Measurement 9 kHz to 30 MHz .....	15
6.5	Radiated Emission in Fully or Semi Anechoic Room .....	17
6.6	Radiated Emission at Open Field Test Site .....	19
6.7	Carrier Frequency Stability .....	21
7	Photographs Taken During Testing .....	23
7.1	Occupied Bandwidth .....	30
7.2	Bandwidth of the Emission .....	40
7.3	Designation of Emissions .....	46
7.4	Conducted Powerline Emission Measurement 150 kHz to 30 MHz .....	47
7.5	Spectrum Mask .....	50
7.6	Radiated Emission Measurement 9 kHz to 30 MHz .....	55
7.7	Radiated Emission Measurement 30 MHz to 1 GHz .....	61
7.8	Carrier Frequency Stability .....	70
7.9	Exposure of Humans to RF Fields .....	75
8	Referenced Regulations .....	77
9	Revision History .....	79



## 1 Description of the Equipment Under Test (EUT)

### General data of EUT

Type designation <sup>1</sup> :	RF350R
Parts <sup>2</sup> :	
Serial number(s):	#1
Manufacturer:	Siemens AG
Type of equipment:	RFID Reader
Version:	As delivered
FCC ID:	<FCC ID>
Additional parts/accessories:	Antennas: <ul style="list-style-type: none"><li>- MOBY E ANT 1</li><li>- MOBY E ANT 12</li><li>- MOBY E ANT 18</li><li>- MOBY E ANT 30</li></ul>

<sup>1</sup> Type designation of the system if EUT consists of more than one part.

<sup>2</sup> Type designations of the parts of the system, if applicable.



Technical data of EUT	
Application frequency range:	<Application Frequency Range>
Frequency range:	13.553 – 13.567 MHz
Operating frequency:	13.56 MHz
Type of modulation:	AM
Pulse train:	N/A
Pulse width:	N/A
Number of RF-channels:	1
Channel spacing:	N/A
Designation of emissions <sup>3</sup> :	10K0A1D
Type of antenna:	External
Antennas covered by this report:	- MMOBY E ANT1 - MOBY E ANT 12 - MOBY E ANT 18 - MOBY E ANT 30
Connection of antenna:	<input checked="" type="checkbox"/> detachable <input type="checkbox"/> not detachable
Type of power supply:	AC supply
Specifications for power supply:	nominal voltage: 24 V minimum voltage: 21.6 V maximum voltage: 26.4 V  nominal frequency: DC Hz

<sup>3</sup> Also known as "Class of Emission".

## 2 Administrative Data

### Application details

Applicant (full address):	Siemens AG Siemensstrasse 2-4 D-90766 Fürth
Contact person:	Norbert Wluka
Order number:	N/A
Receipt of EUT:	August 2009
Date(s) of test:	September 2009
Note(s):	

### Report details

Report number:	19201-00707-3
Edition:	1
Issue date:	August 21, 2009

### 3 Identification of the Test Laboratory

#### Details of the Test Laboratory

Company name:	TÜV SÜD SENTON GmbH
Address:	Aeussere Fruehlingstrasse 45 D-94315 Straubing Germany
Laboratory accreditation:	DAR-Registration No. DAT-P-171/94-02
FCC test site registration number	90926
Industry Canada test site registration:	3050A-1
Contact person:	Mr. Johann Roidt
	Phone: +49 9421 5522-0 Fax: +49 9421 5522-99

## 4 Summary

### Summary of test results

The tested sample complies with the requirements set forth in the

**Code of Federal Regulations CFR 47, Part 15, Sections 15.205, 15.207, 15.215 and 15.225**

of the Federal Communication Commission (FCC) and the

**Radio Standards Specifications  
RSS-Gen Issue 2, Section 7.2.2 and  
RSS-210 Issue 7, Sections 2.2, 2.6, A2.6 (Category I Equipment)**

of Industry Canada (IC).

### Personnel involved in this report

Laboratory Manager:



Mr. Johann Roidt

Responsible for testing:

Mr. Johann Roidt

Responsible for test report:

Mr. Johann Roidt

## 5 Operation Mode and Configuration of EUT

### Operation Mode(s)

Continuously reading a transponder in ISO- and RF300 Mode

### Configuration(s) of EUT

Stand alone

### List of ports and cables

<i>Port</i>	<i>Description</i>	<i>Classification<sup>4</sup></i>	<i>Cable type</i>	<i>Cable length</i>
1	DC power input	dc power	Unshielded	> 3 m
2	Interface to controller	signal/control port	Unshielded	> 3 m
3	Antenna port	signal/control port	Shielded	> 3 m

### List of devices connected to EUT

<i>Item</i>	<i>Description</i>	<i>Type Designation</i>	<i>Serial no. or ID</i>	<i>Manufacturer</i>
1	Control unit with ASM 456 interface module	S7	N/A	Siemens AG

### List of support devices

<i>Item</i>	<i>Description</i>	<i>Type Designation</i>	<i>Serial no. or ID</i>	<i>Manufacturer</i>
1	None			

<sup>4</sup> Ports shall be classified as ac power, dc power or signal/control port



## 6 Measurement Procedures

### 6.1 Conducted Output Power

#### Measurement Procedure:

Rules and specifications: CFR 47 Part 2, section 2.1046(a)  
 IC RSS-Gen Issue 2, section 4.8

Guide: CFR 47 Part 2, section 2.1046 / IC RSS-Gen Issue 2

Conducted output power is measured at the RF output terminals (e.g. antenna connector if antenna is detachable) when the transmitter is adjusted in accordance with the tune-up procedure, if applicable. The RF output terminals are connected to a spectrum analyzer and/or a power meter with appropriate sensor. If required, a resistive matching network equal to the impedance specified or employed for the antenna is used as well as dc block and appropriate attenuators (50 Ohms). The electrical characteristics of the radio frequency load attached to the output terminals shall be stated, if applicable.

If a spectrum analyzer is used and no other settings are specified resolution bandwidth shall be selected according to the carrier frequency  $f_c$  and set to 10 kHz ( $150 \text{ kHz} \leq f_c < 30 \text{ MHz}$ ), 100 kHz ( $30 \text{ MHz} \leq f_c < 1 \text{ GHz}$ ) or 1 MHz ( $f_c \geq 1 \text{ GHz}$ ). The video bandwidth shall be at least three times greater than the resolution bandwidth. The settings used have to be indicated within the appropriate test record(s).

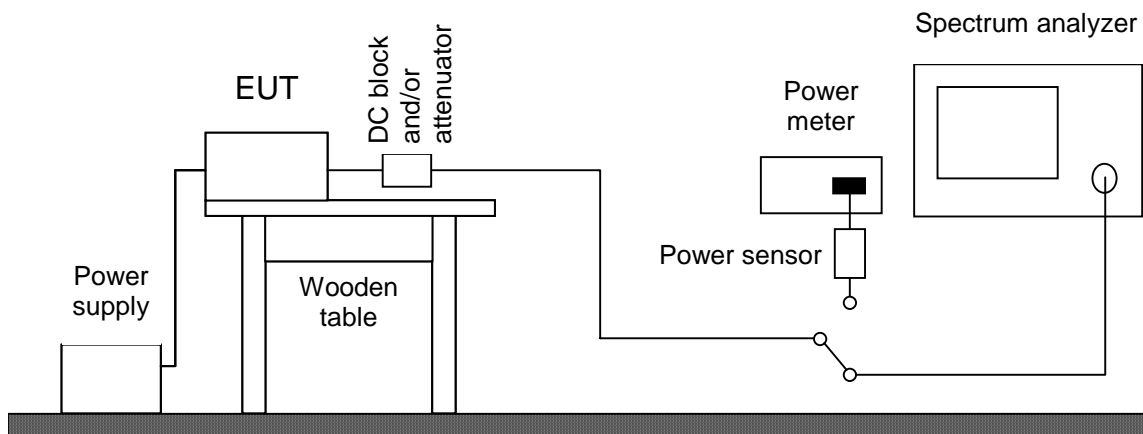



Test instruments used:

Used	Type	Model	Serial No. or ID	Manufacturer
<input type="checkbox"/>	Spectrum Analyzer	FSP 30	100063	Rohde & Schwarz
<input checked="" type="checkbox"/>	EMI test receiver	ESPI7	836914/0002	Rohde & Schwarz
<input type="checkbox"/>	EMI test receiver	ESMI	839379/013 839587/006	Rohde & Schwarz
<input type="checkbox"/>	Power meter	NRVS	836856/015	Rohde & Schwarz
<input type="checkbox"/>	Peak power sensor	NRV-Z31	8579604.03	Rohde & Schwarz
<input type="checkbox"/>	Power sensor	NRV-Z52	837901/030	Rohde & Schwarz
<input type="checkbox"/>	Power sensor	NRV-Z4	863828/015	Rohde & Schwarz
<input type="checkbox"/>	DC-block	7006	A2798	Weinschel
<input type="checkbox"/>	Attenuator	4776-10	9412	Narda
<input type="checkbox"/>	Attenuator	4776-20	9503	Narda

## 6.2 Bandwidth Measurements

Measurement Procedure:	
Rules and specifications:	CFR 47 Part 2, section 2.202(a) CFR 47 Part 15, section 15.215(c) IC RSS-Gen Issue 2, sections 4.6.1 and 4.6.2 IC RSS-210 Issue 7, section A1.1.3 ANSI C63.4, annex H.6
Guide:	ANSI C63.4 / IC RSS-Gen Issue 2, sections 4.6.1 and 4.6.2
Measurement setup:	<input checked="" type="checkbox"/> Conducted: See below <input type="checkbox"/> Radiated: Radiated Emission Measurement 9 kHz to 30 MHz (6.4)
<p>If antenna is detachable bandwidth measurements shall be performed at the antenna connector (conducted measurement) when the transmitter is adjusted in accordance with the tune-up procedure, if applicable. The RF output terminals are connected to a spectrum analyzer. If required, a resistive matching network equal to the impedance specified or employed for the antenna is used as well as dc block and appropriate attenuators (50 Ohms). The electrical characteristics of the radio frequency load attached to the output terminals shall be stated, if applicable.</p> <p>If radiated measurements are performed the same test setups and instruments are used as with radiated emission measurements for the appropriate frequency range.</p> <p>The analyzer settings are specified by the test description of the appropriate test record(s).</p>	

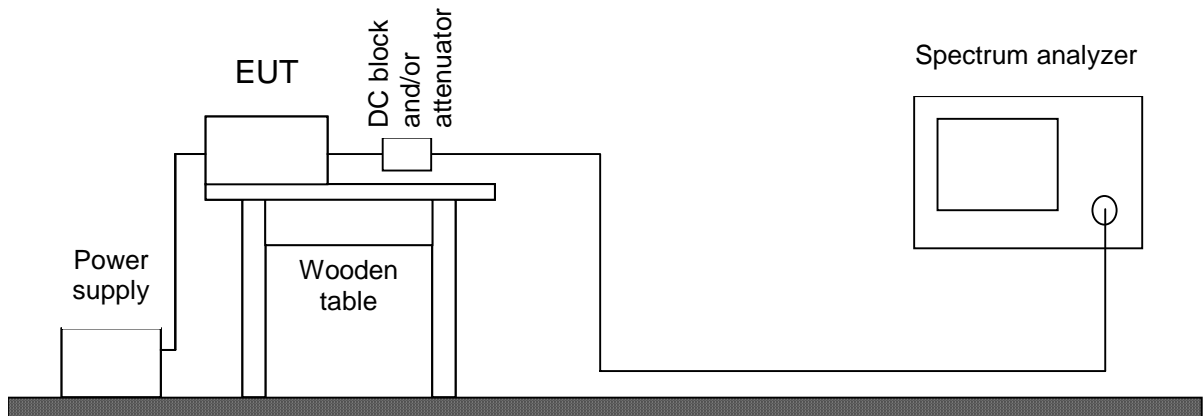

Test instruments used for conducted measurements:

Used	Type	Model	Serial No. or ID	Manufacturer
<input type="checkbox"/>	Spectrum Analyzer	FSP 30	100063	Rohde & Schwarz
<input checked="" type="checkbox"/>	EMI test receiver	ESPI7	836914/0002	Rohde & Schwarz
<input type="checkbox"/>	EMI test receiver	ESMI	839379/013 839587/006	Rohde & Schwarz
<input type="checkbox"/>	Power meter	NRVS	836856/015	Rohde & Schwarz
<input type="checkbox"/>	Peak power sensor	NRV-Z31	8579604.03	Rohde & Schwarz
<input type="checkbox"/>	Power sensor	NRV-Z52	837901/030	Rohde & Schwarz
<input type="checkbox"/>	Power sensor	NRV-Z4	863828/015	Rohde & Schwarz
<input type="checkbox"/>	DC-block	7006	A2798	Weinschel
<input type="checkbox"/>	Attenuator	4776-10	9412	Narda
<input type="checkbox"/>	Attenuator	4776-20	9503	Narda

### 6.3 Conducted AC Powerline Emission

Measurement Procedure:	
Rules and specifications:	CFR 47 Part 15, section 15.207 IC RSS-Gen Issue 2, section 7.2.2
Guide:	ANSI C63.4 / CISPR 22
<p>Conducted emission tests in the frequency range 150 kHz to 30 MHz are performed using Line Impedance Stabilization Networks (LISNs). To simplify testing with quasi-peak and average detector the following procedure is used:</p> <p>First the whole spectrum of emission caused by the equipment under test (EUT) is recorded with detector set to peak using CISPR bandwidth of 10 kHz. After that all emission levels having less margin than 10 dB to or exceeding the average limit are retested with detector set to quasi-peak.</p> <p>If average limit is kept with quasi-peak levels no additional scan with average detector is necessary. In cases of emission levels between quasi-peak and average limit an additional scan with detector set to average is performed.</p> <p>According to ANSI C63.4, section 13.1.3.1, testing of intentional radiators with detachable antenna shall be performed using a suitable dummy load connected to the antenna output terminals. Otherwise, the tests shall be made with the antenna connected and, if adjustable, fully extended.</p> <p>Testing with dummy load may be necessary to distinguish (unintentional) conducted emissions on the supply lines from (intentional) emissions radiated by the antenna and coupling directly to supply lines and/or LISN.</p> <p>Usage of dummy load has to be stated in the appropriate test record(s) and notes should be added to clarify the test setup.</p>	

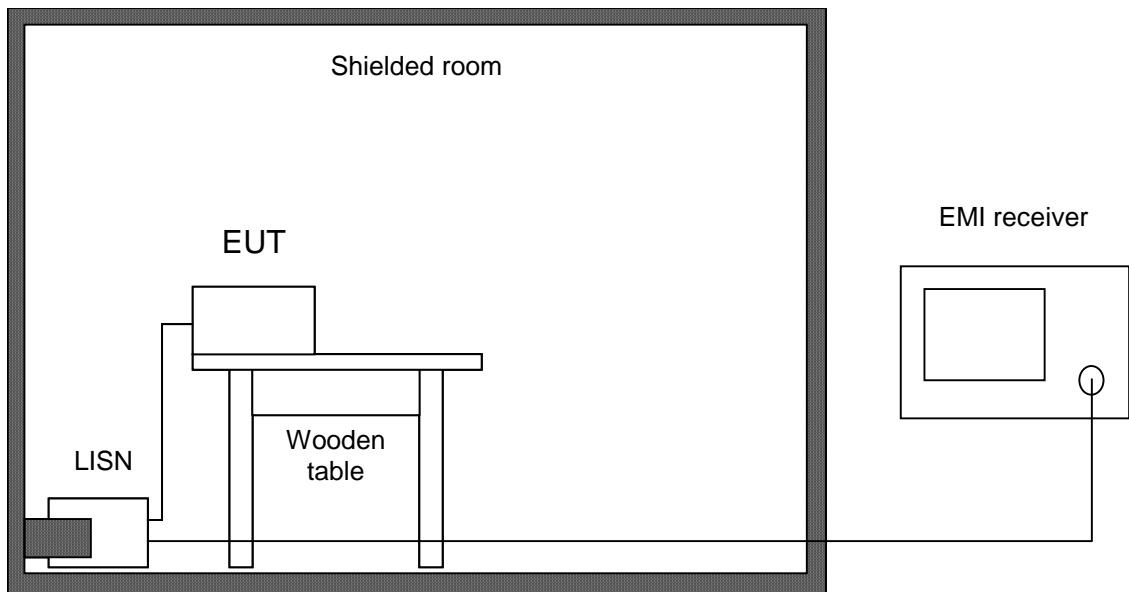

Test instruments used:

Used	Type	Model	Serial No. or ID	Manufacturer
<input checked="" type="checkbox"/>	EMI receiver	ESHS 10	860043/016	Rohde & Schwarz
<input checked="" type="checkbox"/>	LISN	ESH3-Z5	862770/021	Rohde & Schwarz
<input type="checkbox"/>	LISN	ESH3-Z5	830952/025	Rohde & Schwarz
<input type="checkbox"/>	Artificial mains network	ESH 2-Z5	842966/004	Rohde & Schwarz
<input type="checkbox"/>	Shielded room	No. 1	1451	Albatross Projects
<input checked="" type="checkbox"/>	Shielded room	No. 4	3FD-100 544	Euroshield

## 6.4 Radiated Emission Measurement 9 kHz to 30 MHz

### Measurement Procedure:

Rules and specifications: CFR 47 Part 15, sections 15.205, 15.215(b) and 15.225(a)-(d)  
 IC RSS-210 Issue 7, sections 2.2, 2.6 and A2.6

Guide: ANSI C63.4

Radiated emission in the frequency range 9 kHz to 30 MHz is measured using an active loop antenna. First the whole spectrum of emission caused by the equipment is recorded at a distance of 3 meters in a fully or semi anechoic room with the detector of the spectrum analyzer or EMI receiver set to peak. This configuration is also used for recording the spectrum of intentional radiators.

Hand-held or body-worn devices are rotated through three orthogonal axes to determine which attitude and configuration produces the highest emission relative to the limit and therefore shall be used for final testing.

EUT is rotated all around to find the maximum levels of emissions. Equipment and cables are placed and moved within the range of position likely to find their maximum emissions.

If worst case emission of the EUT cannot be recorded with EUT in standard position and loop antenna in vertical polarization the EUT (or the radiating part of the EUT) is rotated by 90 degrees instead of changing the loop antenna to horizontal polarization. This procedure is selected to minimize the influence of the environment (e.g. effects caused by the floor especially with longer distances).

Final measurement is performed at a test distance D of 30 meters using an open field test site. In case the regulation requires testing at other distances, the result is extrapolated by either making measurements at an additional distance D of 10 meters to determine the proper extrapolation factor or by using the square of an inverse linear distance extrapolation factor (40 dB/decade). In cases of very low emissions measurements are performed at shorter distances and results are extrapolated to the required distance. The provisions of CFR 47 Part 15 sections 15.31(d) and (f)(2) apply. According to CFR 47 Part 15 section 15.209(d) final measurement is performed with detector function set to quasi-peak except for the frequency bands 9 to 90 kHz and 110 to 490 kHz where, for non-pulsed operation, average detector is employed.

If the radiated emission limits are expressed in terms of the average value of the emission there also is a peak limit corresponding to 20 dB above the maximum permitted average limit. Additionally, if pulsed operation is employed, the average field strength is determined by averaging over one complete pulse train, including blanking intervals, as specified in CFR 47 Part 15 section 15.35(c). If the pulse train exceeds 0.1 second that 0.1 second interval during which the value of the emission is at its maximum is selected for calculation. The pulse train correction is added to the peak value of the emission to get the average value.

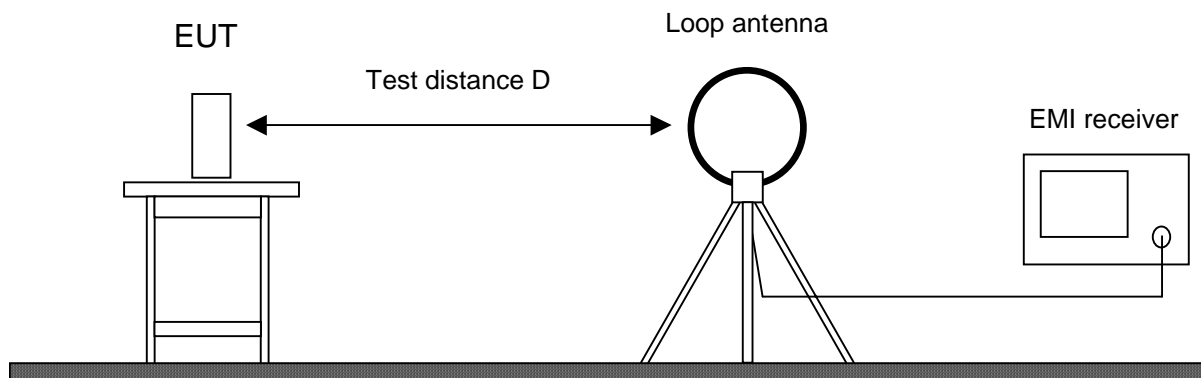

Test instruments used:

Used	Type	Model	Serial No. or ID	Manufacturer
<input checked="" type="checkbox"/>	Spectrum Analyzer	FSP 30	100063	Rohde & Schwarz
<input type="checkbox"/>	EMI test receiver	ESMI	839379/013 839587/006	Rohde & Schwarz
<input checked="" type="checkbox"/>	Test receiver	ESHS 10	860043/016	Rohde & Schwarz
<input type="checkbox"/>	Preamplifier	CPA9231A	3393	Schaffner
<input type="checkbox"/>	Loop antenna	HFH2-Z2	882964/1	Rohde & Schwarz
<input checked="" type="checkbox"/>	Fully anechoic room	No. 2	1452	Albatross Projects
<input type="checkbox"/>	Semi-anechoic room	No. 3	1453	Siemens
<input checked="" type="checkbox"/>	Open field test site	EG 1	1450	Senton



## 6.5 Radiated Emission in Fully or Semi Anechoic Room

### Measurement Procedure:

Rules and specifications:	CFR 47 Part 15, sections 15.205(b) and 15.225(d) IC RSS-210 Issue 7, sections 2.2(b)(c), 2.6 and A2.6
Guide:	ANSI C63.4

Radiated emission in fully or semi anechoic room is measured in the frequency range from 30 MHz to the maximum frequency as specified in CFR 47 Part 15 section 15.33.

Measurements are made in both the horizontal and vertical planes of polarization in a fully anechoic room using a spectrum analyzer with the detector function set to peak and resolution as well as video bandwidth set to 100 kHz (below 1 GHz) or 1 MHz (above 1 GHz).

Testing up to 1 GHz is performed with a linear polarized logarithmic periodic antenna combined with a 4:1 broadband dipole ("Trilog broadband antenna"). For testing above 1 GHz horn antennas are used.

All tests below 8.2 GHz are performed at a test distance D of 3 meters. For higher frequencies the test distance may be reduced (e.g. to 1 meter) due to the sensitivity of the measuring instrument(s) and the test results are calculated according to CFR 47 Part 15 section 15.31(f)(1) using an extrapolation factor of 20 dB/decade. If required, preamplifiers are used for the whole frequency range. Special care is taken to avoid overload, using appropriate attenuators and filters, if necessary.

If the radiated emission limits are expressed in terms of the average value of the emission there also is a peak limit corresponding to 20 dB above the maximum permitted average limit. Additionally, if pulsed operation is employed, the average field strength is determined by averaging over one complete pulse train, including blanking intervals, as specified in CFR 47 Part 15 section 15.35(c). If the pulse train exceeds 0.1 second that 0.1 second interval during which the value of the emission is at its maximum is selected for calculation. The pulse train correction is added to the peak value of the emission to get the average value.

Hand-held or body-worn devices are rotated through three orthogonal axes to determine which attitude and configuration produces the highest emission relative to the limit and therefore shall be used for final testing.

During testing the EUT is rotated all around to find the maximum levels of emissions. Equipment and cables are placed and moved within the range of position likely to find their maximum emissions.

For final testing below 1 GHz an open field test-site is used and the plots recorded in the fully or semi anechoic room are indicated as prescans.

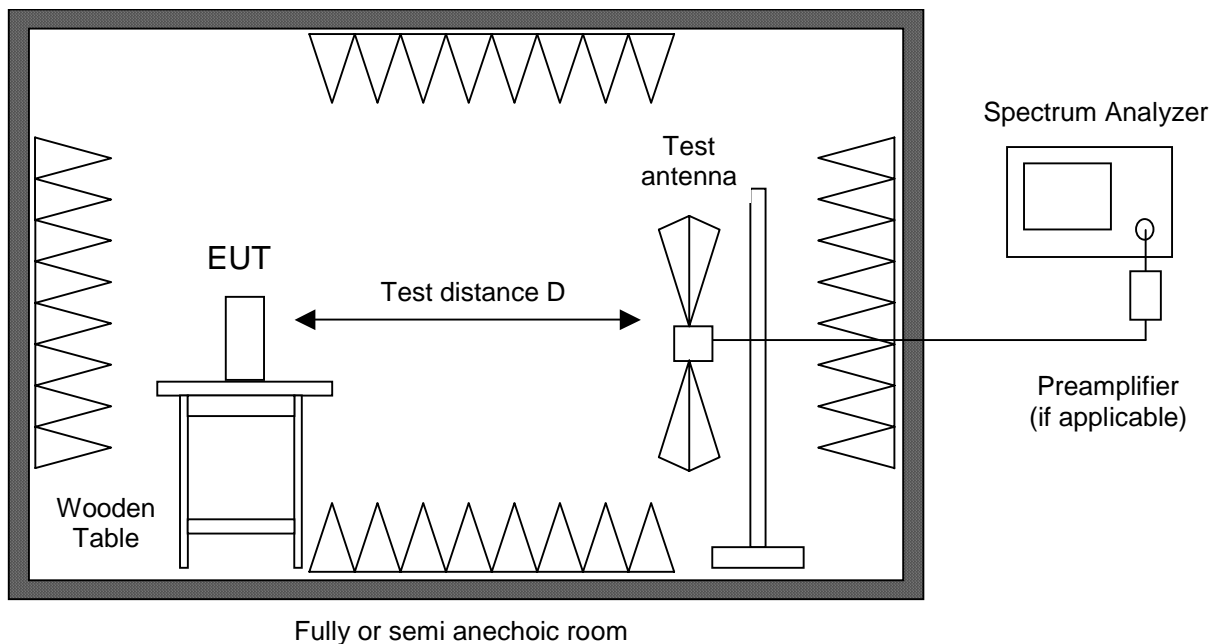

Test instruments used:

Used	Type	Model	Serial No. or ID	Manufacturer
<input checked="" type="checkbox"/>	Spectrum Analyzer	FSP 30	100063	Rohde & Schwarz
<input type="checkbox"/>	EMI test receiver	ESPI7	101018	Rohde & Schwarz
<input type="checkbox"/>	EMI test receiver	ESMI	839379/013 839587/006	Rohde & Schwarz
<input checked="" type="checkbox"/>	Preamplifier	CPA9231A	3393	Schaffner
<input type="checkbox"/>	Preamplifier	R14601		Advantest
<input type="checkbox"/>	Preamplifier 1-8 GHz	AFS3-00100800-32-LN	847743	Miteq
<input type="checkbox"/>	Preamplifier 0.5-8 GHz	AMF-4D-005080-25-13P	860149	Miteq
<input type="checkbox"/>	Preamplifier 8-18 GHz	ACO/180-3530	32641	CTT
<input type="checkbox"/>	External Mixer	WM782A	845881/005	Tektronix
<input type="checkbox"/>	Harmonic Mixer	FS-Z30	843389/007	Rohde & Schwarz
	Accessories			
<input checked="" type="checkbox"/>	Trilog broadband antenna	VULB 9163	9163-188	Schwarzbeck
<input type="checkbox"/>	Horn antenna	3115	9508-4553	EMCO
<input type="checkbox"/>	Horn antenna	3160-03	9112-1003	EMCO
<input type="checkbox"/>	Horn antenna	3160-04	9112-1001	EMCO
<input type="checkbox"/>	Horn antenna	3160-05	9112-1001	EMCO
<input type="checkbox"/>	Horn antenna	3160-06	9112-1001	EMCO
<input type="checkbox"/>	Horn antenna	3160-07	9112-1008	EMCO
<input type="checkbox"/>	Horn antenna	3160-08	9112-1002	EMCO
<input type="checkbox"/>	Horn antenna	3160-09	9403-1025	EMCO
<input type="checkbox"/>	Horn antenna	3160-10	399185	EMCO
<input checked="" type="checkbox"/>	Fully anechoic room	No. 2	1452	Albatross Projects
<input type="checkbox"/>	Semi-anechoic room	No. 3	1453	Siemens

## 6.6 Radiated Emission at Open Field Test Site

### Measurement Procedure:

Rules and specifications: CFR 47 Part 15, sections 15.205(b) and 15.225(d)  
 IC RSS-210 Issue 7, sections 2.2(b)(c), 2.6 and A2.6

Guide: ANSI C63.4

Radiated emission at open field test site is measured in the frequency range 30 MHz to 1 GHz using a biconical antenna up to 300 MHz and a logarithmic periodic antenna above. The measurement bandwidth of the test receiver is set to 120 kHz with quasi-peak detector selected.

If the radiated emission limits are expressed in terms of the average value of the emission there also is a peak limit corresponding to 20 dB above the maximum permitted average limit. Additionally, if pulsed operation is employed, the average field strength is determined by averaging over one complete pulse train, including blanking intervals, as specified in CFR 47 Part 15 section 15.35(c). If the pulse train exceeds 0.1 second that 0.1 second interval during which the value of the emission is at its maximum is selected for calculation. The pulse train correction is added to the peak value of the emission to get the average value.

Hand-held or body-worn devices are tested in the position producing the highest emission relative to the limit as verified by prescans in the fully anechoic room. EUT is rotated all around and receiving antenna is raised and lowered within 1 meter to 4 meters to find the maximum levels of emission. Equipment and cables are placed and moved within the range of position likely to find their maximum emissions.

For measuring emissions of intentional radiators and receivers a test distance  $D$  of 3 meters is selected. Testing of unintentional radiators is performed at a distance of 10 meters. If limits specified for 3 meters shall be used for measurements performed at 10 meters distance the limits are calculated according to CFR 47 Part 15 section 15.31(d) and (f)(1) using an inverse linear-distance extrapolation factor of 20 dB/decade.

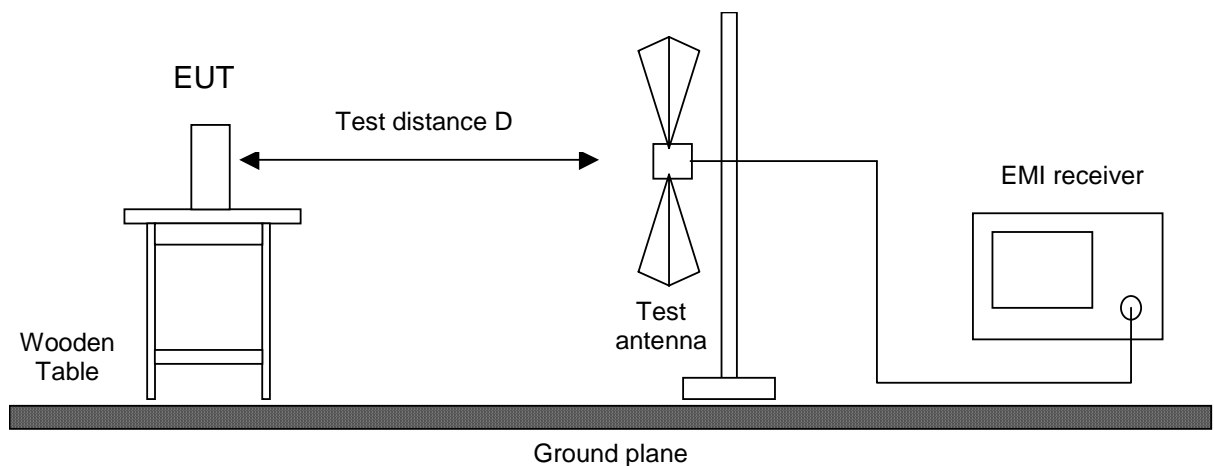

Test instruments used:

Used	Type		Model	Serial No. or ID	Manufacturer
<input checked="" type="checkbox"/>	EMI receiver	EG 1	ESVP	881120/024	Rohde & Schwarz
<input type="checkbox"/>	EMI receiver		ESVP	891846/003	Rohde & Schwarz
<input checked="" type="checkbox"/>	Biconical antenna	EG 1	HK 116	842204/001	Rohde & Schwarz
<input checked="" type="checkbox"/>	Log. per. antenna	EG 1	HL 223	841516/023	Rohde & Schwarz
<input checked="" type="checkbox"/>	Open field test site		EG 1	1450	Senton

## 6.7 Carrier Frequency Stability

### Measurement Procedure:

Rules and specifications:	CFR 47 Part 15, section 15.225(e) IC RSS-Gen Issue 2, section 4.7 and IC RSS-210 Issue 7, section A2.6
Guide:	ANSI C63.4

The frequency tolerance of the carrier signal is measured over a temperature variation of -20 °C to +50 °C at normal supply voltage, and for a variation in the primary supply voltage from 85% to 115% of the rated supply voltage at a temperature of 20 °C.

If the EUT provides an antenna connector the spectrum analyzer is connected to this port. If required, a resistive matching network equal to the impedance specified or employed for the antenna is used as well as dc block and appropriate attenuators (50 Ohms). In cases where the EUT does not provide an antenna connector a test fixture is used.

For battery operated equipment, the test is performed using a new battery. Alternatively, an external supply voltage can be used and is at least set to:

- the maximum battery voltage as delivered by a new battery or 115% of the battery nominal voltage
- the battery nominal voltage
- 85% of the battery nominal voltage
- the battery operating end point voltage which shall be specified by the equipment manufacturer

The EUT is operating providing an unmodulated carrier. The peak detector of the spectrum analyzer is selected and resolution as well as video bandwidth are set to values appropriate to the shape of the spectrum of the EUT. The frequency counter mode of the spectrum analyzer is used to maximize the accuracy of the measured frequency tolerance.

If an unmodulated carrier is not available a significant and stable point on the spectrum is selected and the span is reduced to a value that delivers an accuracy which shall be better than 1% of the maximum frequency tolerance allowed for the carrier signal. This method may be performed as long as the margin to the frequency tolerance allowed is larger than the uncertainty of the measured frequency tolerance.

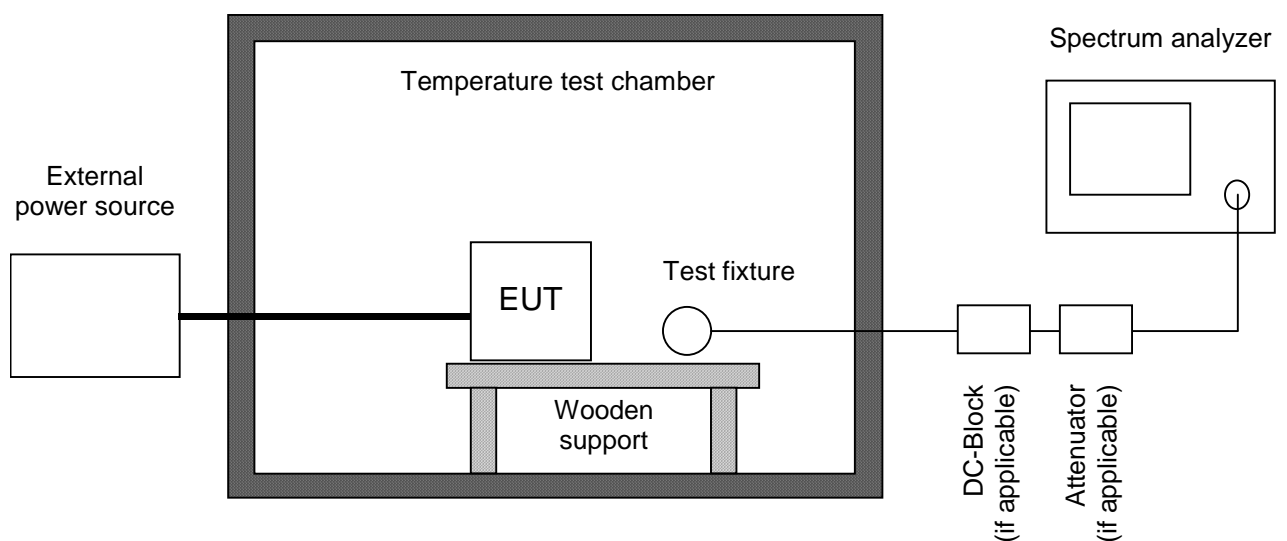



Test instruments used:

Used	Type	Model	Serial No. or ID	Manufacturer
<input type="checkbox"/>	Spectrum Analyzer	FSP 30	100063	Rohde & Schwarz
<input checked="" type="checkbox"/>	EMI test receiver	ESPI7	836914/0002	Rohde & Schwarz
<input type="checkbox"/>	EMI test receiver	ESMI	839379/013 839587/006	Rohde & Schwarz
<input type="checkbox"/>	DC-block	7006	A2798	Weinschel
<input type="checkbox"/>	Attenuator	4776-10	9412	Narda
<input type="checkbox"/>	Attenuator	4776-20	9503	Narda
<input type="checkbox"/>	Test probe	TP01	001	Senton
<input type="checkbox"/>	Multimeter	21 III	76530546	Fluke
<input type="checkbox"/>	Multimeter	21 III	76381229	Fluke
<input type="checkbox"/>	Multimeter	Fluke 77 III	92370108	Fluke
<input type="checkbox"/>	Multimeter	Fluke 77 IV	93090238	Fluke
<input type="checkbox"/>	Multimeter	Fluke 177	96720024	Fluke
<input type="checkbox"/>	Multimeter	Fluke 177	96720025	Fluke
<input checked="" type="checkbox"/>	DC power supply	NGSM 32/10	203	Rohde & Schwarz
<input type="checkbox"/>	Isolating transformer	RT 5A	10387	Grundig
<input type="checkbox"/>	Isolating transformer	RT 5A	10416	Grundig
<input checked="" type="checkbox"/>	Temperature test chamber	HT4010	07065550	Heraeus

---

## 7 Photographs Taken During Testing

## Test setup for conducted AC powerline emission measurement





**Test setup for radiated emission measurement 9 kHz – 30 MHz**

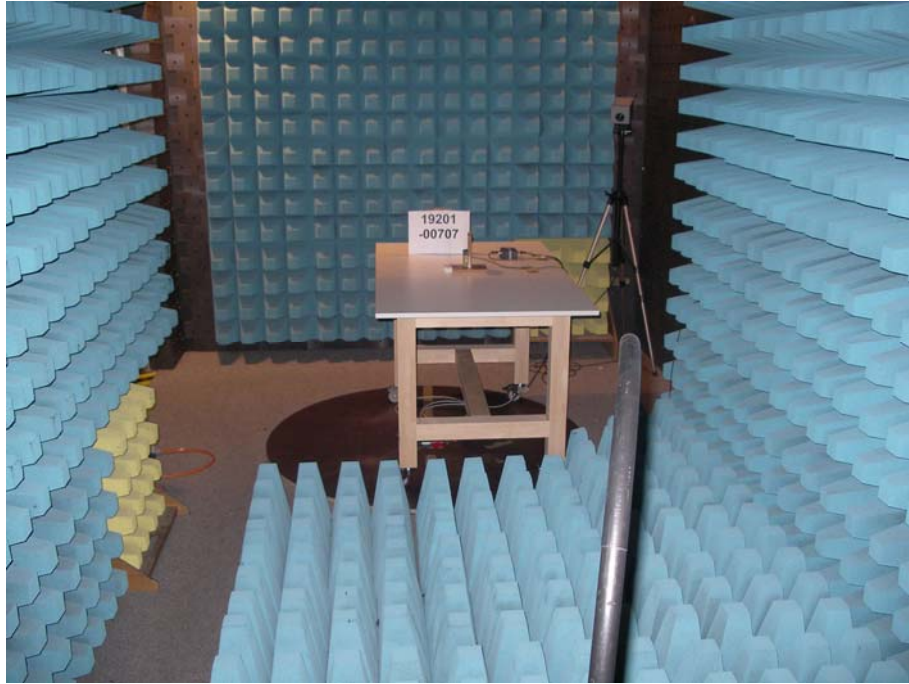

**Test setup for radiated emission measurement  
(fully anechoic room)**



## Test setup for radiated emission measurement (open field test site)



## Test Results

<b>FCC CFR 47 Parts 2 and 15</b>			
<i>Section(s)</i>	<i>Test</i>	<i>Page</i>	<i>Result</i>
2.1046(a)	Conducted output power	---	Not applicable
2.202(a)	Occupied bandwidth	30	Recorded
15.215(c)	Bandwidth of the emission	40	Test passed
2.201, 2.202	Class of emission	46	Calculated
15.35(c)	Pulse train measurement for pulsed operation	---	Not applicable
15.205(a) 15.205(d)(7)	Restricted bands of operation	--- <sup>5</sup>	Test passed
15.207	Conducted AC powerline emission 150 kHz to 30 MHz	47	Test passed
15.225(a)-(d)	Spectrum Mask	50	Test passed
15.205(b) 15.215(b) 15.225(a)(d)	Radiated emission 9 kHz to 30 MHz	55	Test passed
15.205(b) 15.225(d)	Radiated emission 30 MHz to 1 GHz	61	Test passed
15.225(e)	Carrier frequency stability	70	Test passed

<sup>5</sup> See "Spectrum Mask" for the 13.36 to 13.41 MHz band. For all other restricted bands see "Radiated Emission".



<b>IC RSS-Gen Issue 2</b>			
<i>Section(s)</i>	<i>Test</i>	<i>Page</i>	<i>Result</i>
4.8	Transmitter output power (conducted)	---	Not applicable
4.6.1	Occupied Bandwidth	30	Recorded
3.2(h), 8	Designation of emissions	46	Calculated
4.5	Pulsed operation	---	Not applicable
7.2.2	Transmitter AC power lines conducted emissions 150 kHz to 30 MHz	47	Test passed
5.5	Exposure of Humans to RF Fields	75	Exempted from SAR and RF evaluation

<b>IC RSS-210 Issue 7</b>			
<i>Section(s)</i>	<i>Test</i>	<i>Page</i>	<i>Result</i>
2.2(a)	Restricted bands and unwanted emission frequencies	--- <sup>6</sup>	Test passed
A2.6	Spectrum Mask	50	Test passed
2.2(b)(c), 2.6 A2.6	Unwanted emissions 9 kHz to 30 MHz	55	Test passed
2.2(b)(c), 2.6 A2.6	Unwanted emissions 30 MHz to 1 GHz	61	Test passed
A2.6	Carrier frequency stability	70	Test passed

<sup>6</sup> See "Spectrum Mask" and "Unwanted emissions".

## 7.1 Occupied Bandwidth

Rules and specifications:	CFR 47 Part 2, section 2.202(a) ANSI C63.4, annex H.6	
Guide:	ANSI C63.4	
Description:	The occupied bandwidth according to CFR 47 Part 2, section 2.202(a), is measured as the 99% emission bandwidth, i.e. below its lower and above its upper frequency limits, the mean powers radiated are each equal to 0.5% of the total mean power radiated by a given emission.	
	The occupied bandwidth according to ANSI C63.4, annex H.6; is measured as the frequency range defined by the points that are 26 dB down relative to the maximum level of the modulated carrier.	
	The resolution bandwidth of the spectrum analyzer shall be set to a value greater than 5.0% of the allowed bandwidth. If no bandwidth specifications are given, the following guidelines are used:	
	Fundamental frequency	Minimum resolution bandwidth
	9 kHz to 30 MHz	1 kHz
	30 MHz to 1000 MHz	10 kHz
	1000 MHz to 40 GHz	100 kHz
	The video bandwidth shall be at least three times greater than the resolution bandwidth.	
Measurement procedure:	Bandwidth Measurements (6.2)	

Comment:	
Date of test:	10 August 2009
Test site:	Fully anechoic room, cabin no. 2

### Occupied Bandwidth (99 %) ISO-Mode, ANT 1:

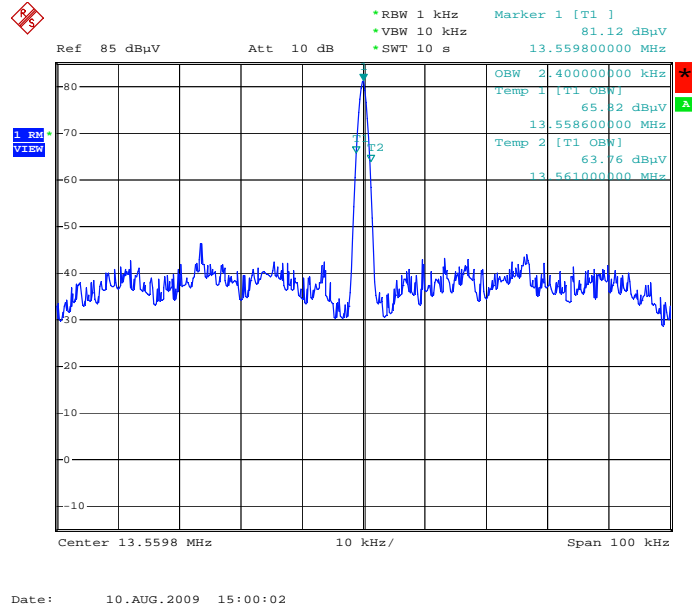

Occupied Bandwidth (99 %):	<b>2.4 kHz</b>
----------------------------	----------------

### Occupied Bandwidth (99 %) ISO-Mode, ANT 12:

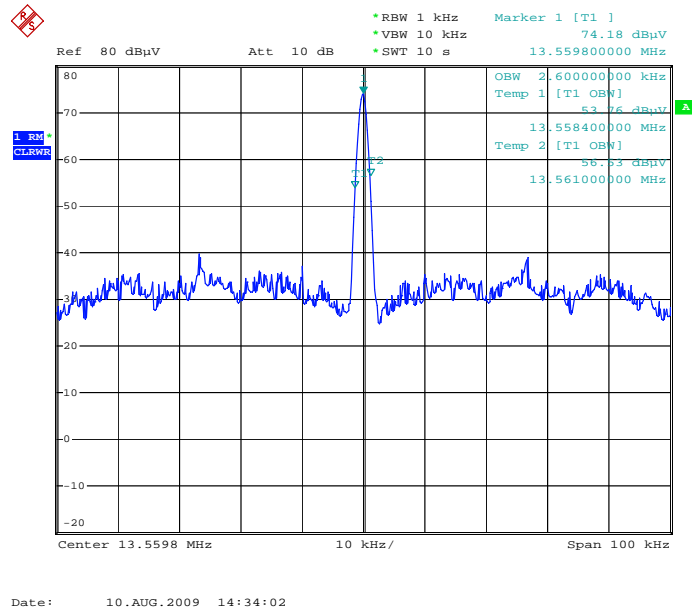

Occupied Bandwidth (99 %):	<b>2.6 kHz</b>
----------------------------	----------------

**Occupied Bandwidth (99 %) ISO-Mode, ANT 18:**

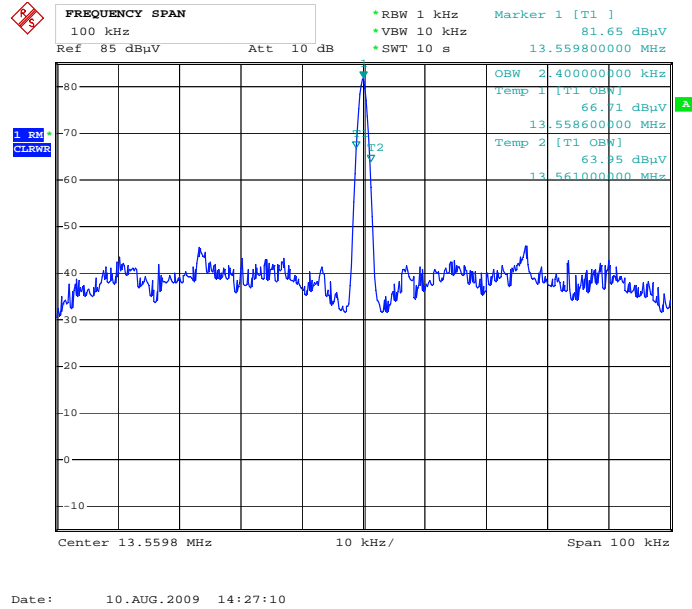

Occupied Bandwidth (99 %): **2.4 kHz**

**Occupied Bandwidth (99 %) ISO-Mode, ANT 30:**

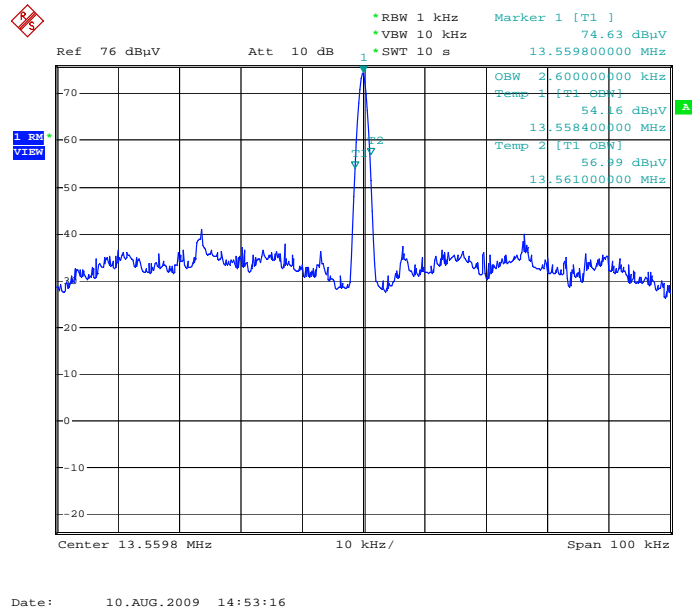

Occupied Bandwidth (99 %): **2.6 kHz**



### Occupied Bandwidth (99 %) RF300-Mode, ANT 1:

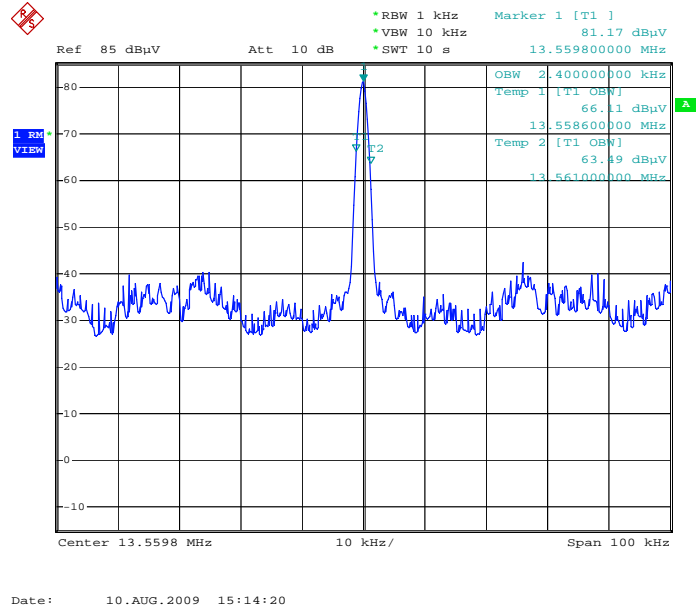

Occupied Bandwidth (99 %): **2.4 kHz**

### Occupied Bandwidth (99 %) Rf300-Mode, ANT 12:

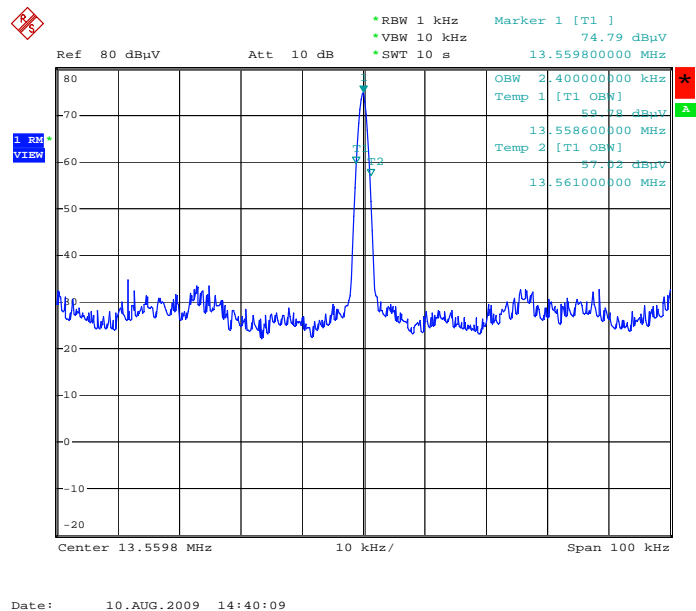

Occupied Bandwidth (99 %): **2.4 kHz**

**Occupied Bandwidth (99 %) RF300-Mode, ANT 18:**

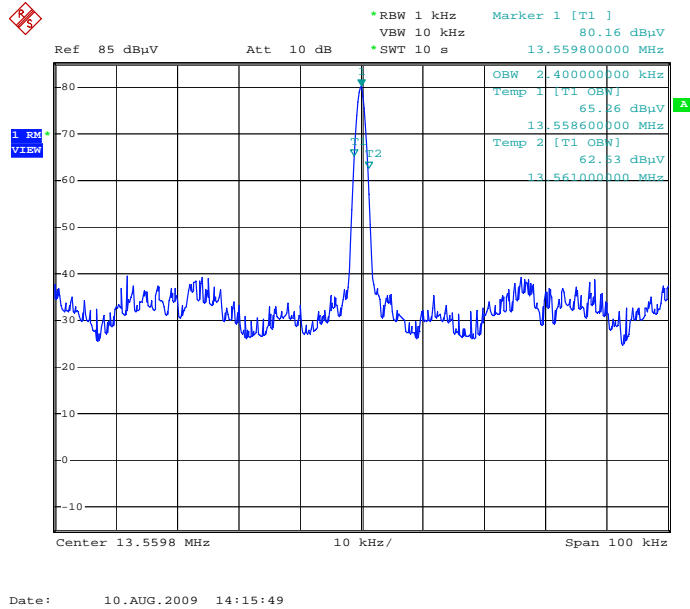

Occupied Bandwidth (99 %): **2.4 kHz**

**Occupied Bandwidth (99 %) RF300-Mode, ANT 30:**

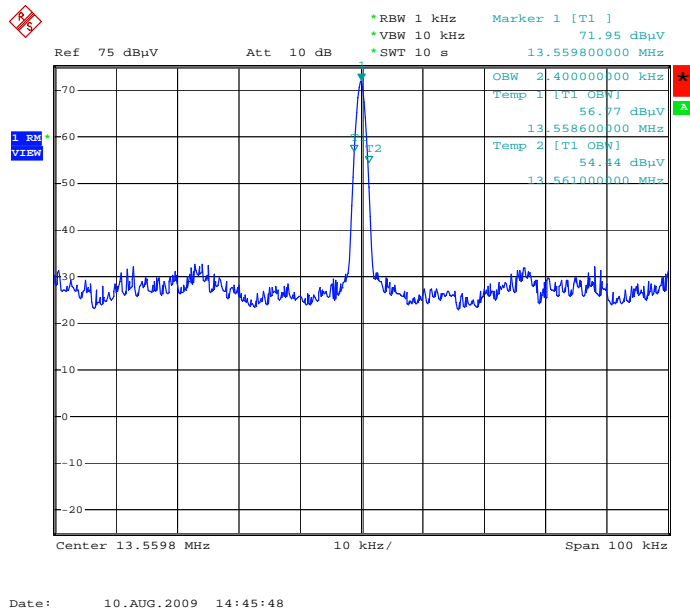

Occupied Bandwidth (99 %): **2.4 kHz**

## Occupied Bandwidth (continued)

Rules and specifications:	IC RSS-Gen Issue 2, section 4.6.1
Guide:	IC RSS-Gen Issue 2, section 4.6.1
Description:	<p>If not specified in the applicable RSS the occupied bandwidth is measured as the 99% emission bandwidth.</p> <p>The span of the analyzer shall be set to capture all products of the modulation process, including the emission skirts. The resolution bandwidth shall be set to as close to 1% of the selected span as is possible without being below 1%. The video bandwidth shall be set to 3 times the resolution bandwidth.</p> <p>The trace data points are recovered and are directly summed in linear terms. The recovered amplitude data points, beginning at the lowest frequency, are placed in a running sum until 0.5% of the total is reached and that frequency recorded. The process is repeated for the highest frequency data points. This frequency is also recorded. The span between the two recorded frequencies is the occupied bandwidth.</p>
Measurement procedure:	Bandwidth Measurements (6.2)

Comment:	
Date of test:	10 August 2009
Test site:	Fully anechoic room, cabin no. 2

### Occupied Bandwidth (99 %), ISO Mode, ANT 1 :

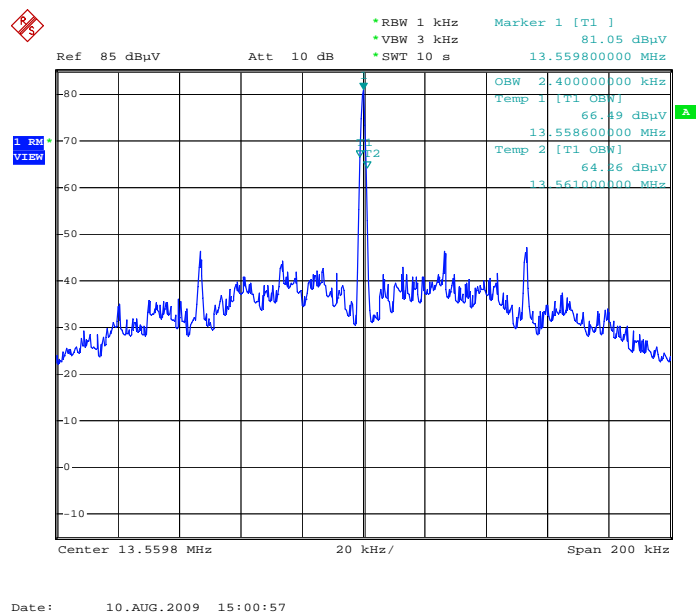

Occupied Bandwidth (99 %):	<b>2.4 kHz</b>
----------------------------	----------------

**Occupied Bandwidth (99 %), ISO Mode, ANT 12 :**

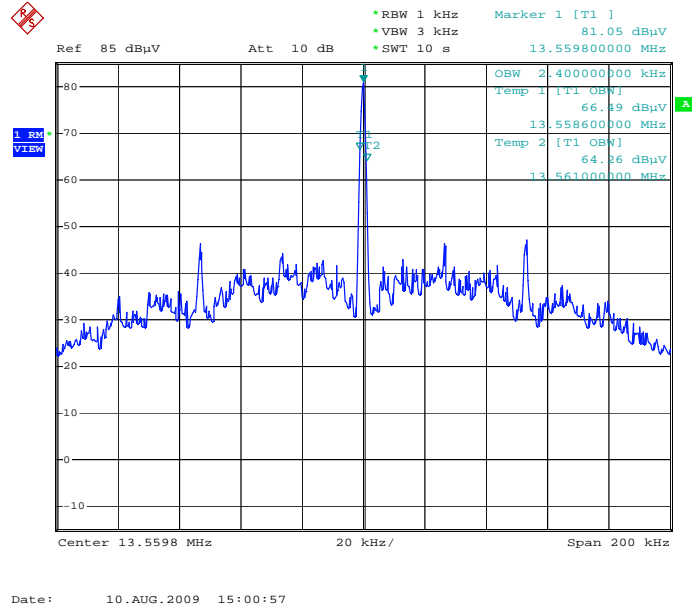

Occupied Bandwidth (99 %): **2.4 kHz**

**Occupied Bandwidth (99 %), ISO Mode, ANT 18 :**

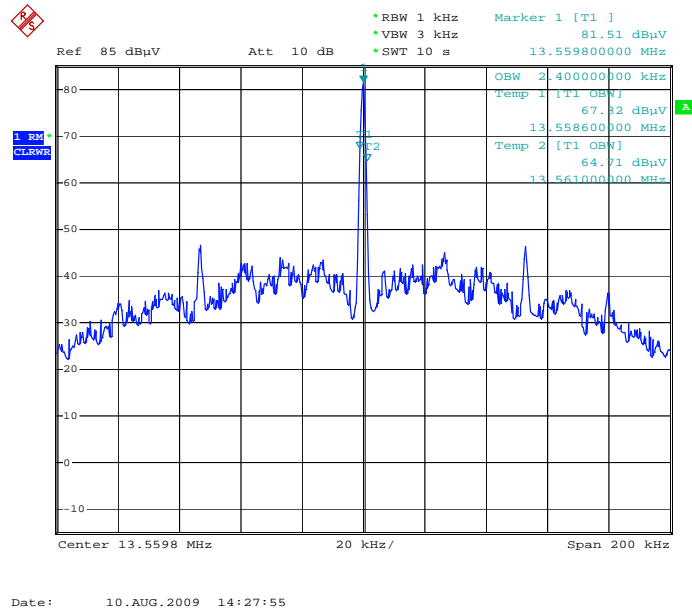

Occupied Bandwidth (99 %): **2.4 kHz**

**Occupied Bandwidth (99 %), ISO Mode, ANT 30 :**

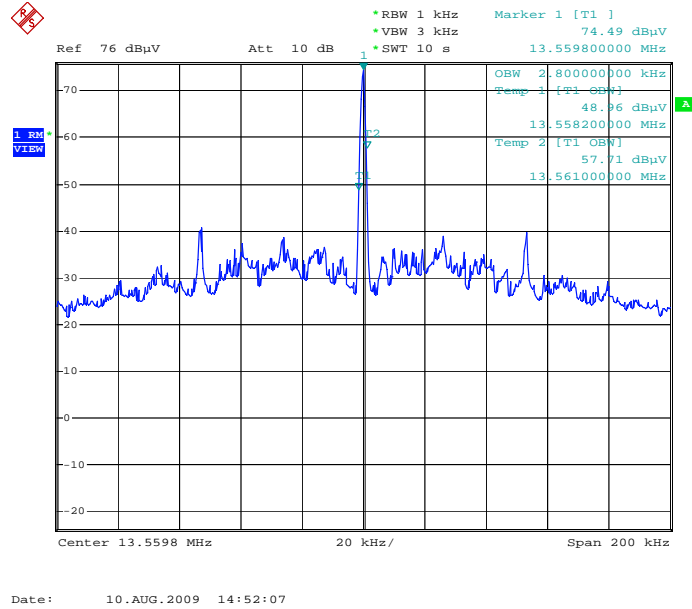

Occupied Bandwidth (99 %): **2.4 kHz**

**Occupied Bandwidth (99 %), RF300 Mode, ANT 1 :**

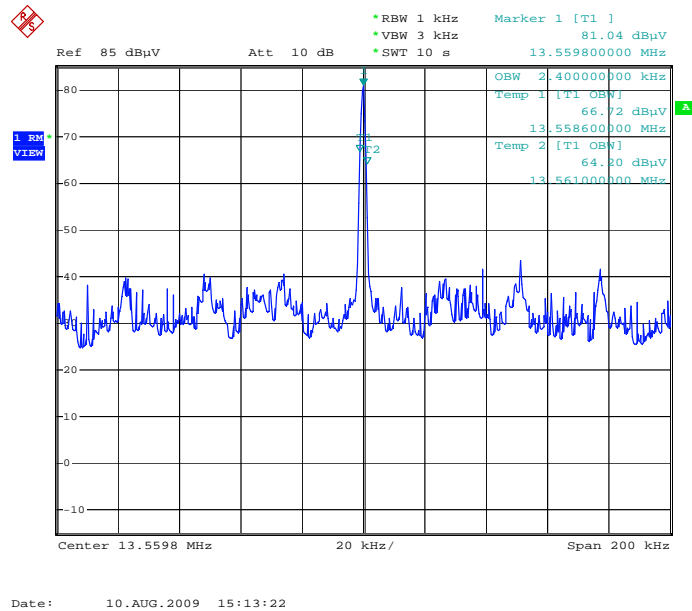

Occupied Bandwidth (99 %): **2.4 kHz**

**Occupied Bandwidth (99 %), RF300 Mode, ANT 12 :**

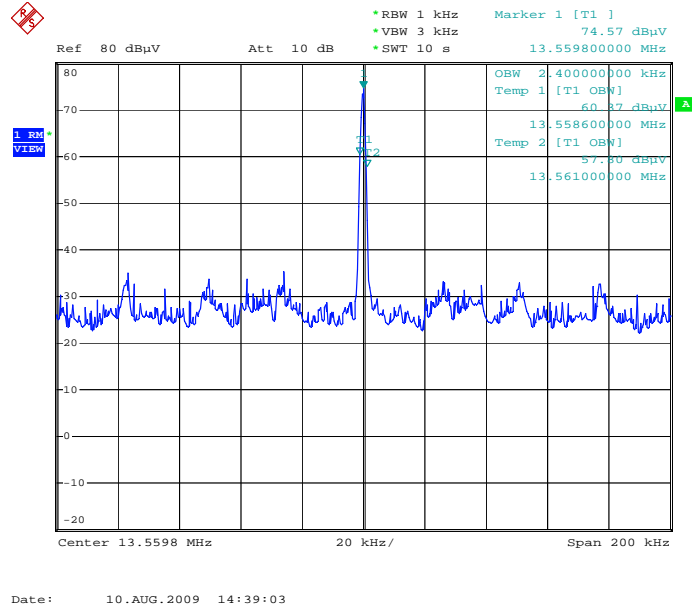

Occupied Bandwidth (99 %):	<b>2.4 kHz</b>
----------------------------	----------------

**Occupied Bandwidth (99 %), RF300 Mode, ANT 18 :**

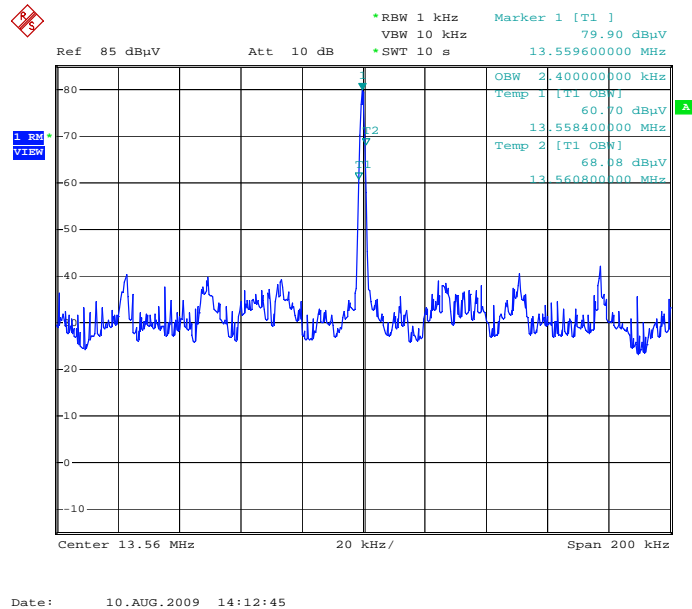

Occupied Bandwidth (99 %):	<b>2.4 kHz</b>
----------------------------	----------------

**Occupied Bandwidth (99 %), RF300 Mode, ANT 30 :**

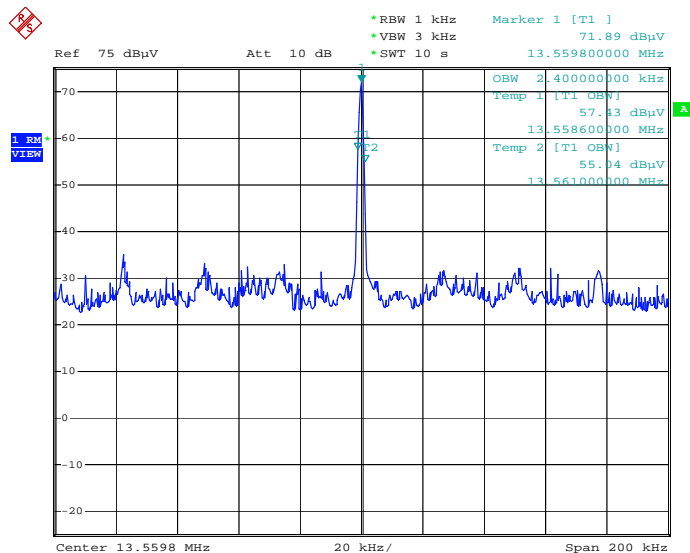

Date: 10.AUG.2009 14:46:54

Occupied Bandwidth (99 %):	<b>2.4 kHz</b>
----------------------------	----------------

## 7.2 Bandwidth of the Emission

Rules and specifications:	CFR 47 Part 15, section 15.215(c)	
Guide:	ANSI C63.4	
Description:	<p>The 20 dB bandwidth of the emission is measured as the frequency range defined by the points that are 20 dB down relative to the maximum level of the modulated carrier.</p> <p>For intentional radiators operating under the alternative provisions to the general emission limits the requirement to contain the 20 dB bandwidth of the emission within the specified frequency band includes the effects from frequency sweeping, frequency hopping and other modulation techniques that may be employed as well as the frequency stability of the transmitter over expected variations in temperature and supply voltage. If a frequency stability is not specified in the regulations, it is recommended that the fundamental emission be kept within at least the central 80% of the permitted band in order to minimize the possibility of out-of-band operation.</p> <p>The resolution bandwidth of the spectrum analyzer shall be set to a value greater than 5.0% of the allowed bandwidth. If no bandwidth specifications are given, the following guidelines are used:</p>	
	Fundamental frequency	Minimum resolution bandwidth
	9 kHz to 30 MHz	1 kHz
	30 MHz to 1000 MHz	10 kHz
	1000 MHz to 40 GHz	100 kHz
The video bandwidth shall be at least three times greater than the resolution bandwidth.		
Measurement procedure:	Bandwidth Measurements (6.2)	

Comment:	
Date of test:	August 10, 2009
Test site:	Fully anechoic room, cabin no. 2



### Bandwidth of the emission – ISO Mode, ANT 1

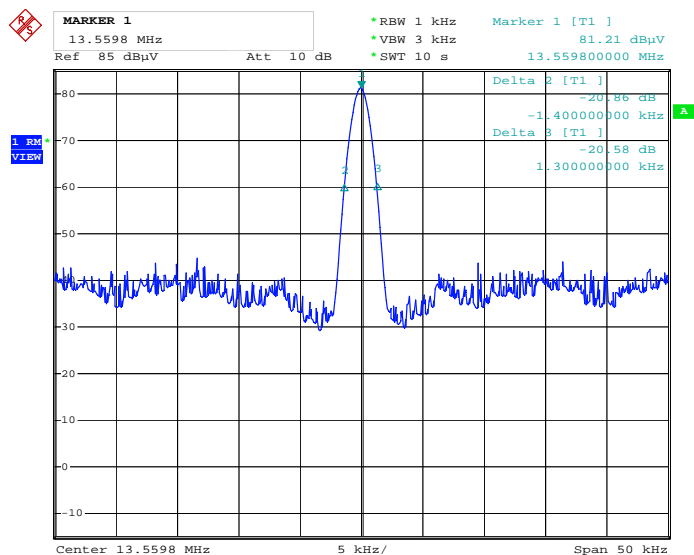

Date: 10.AUG.2009 15:01:54

### Bandwidth of the emission – ISO Mode, ANT 12

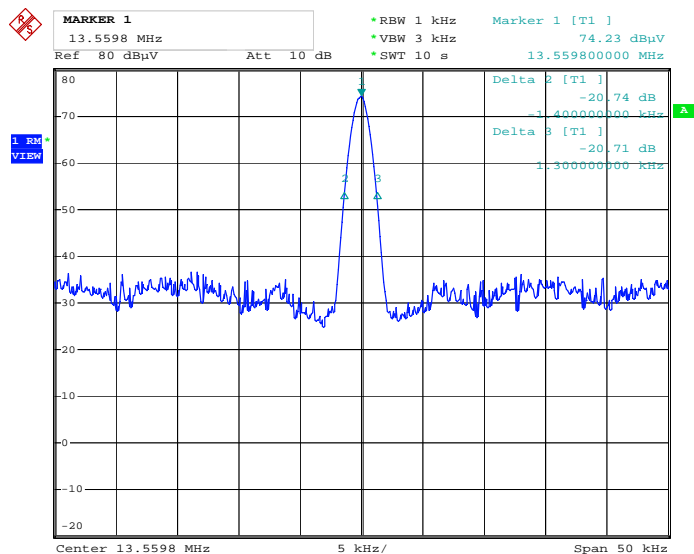

Date: 10.AUG.2009 14:35:27

### Bandwidth of the emission – ISO Mode, ANT 18

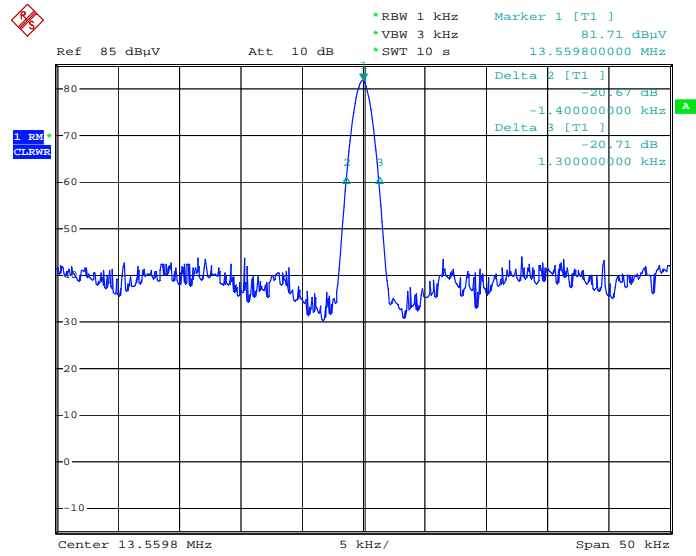

Date: 10.AUG.2009 14:23:31

### Bandwidth of the emission – ISO Mode, ANT 30

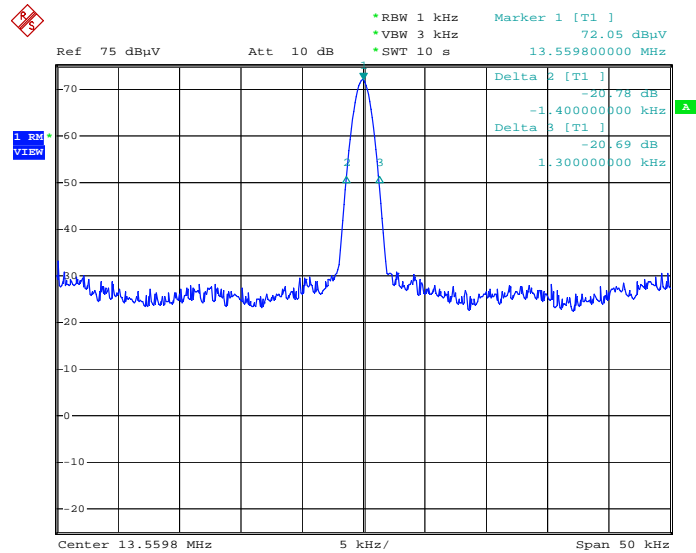

Date: 10.AUG.2009 14:48:08

### Bandwidth of the emission – RF300 Mode, ANT 1

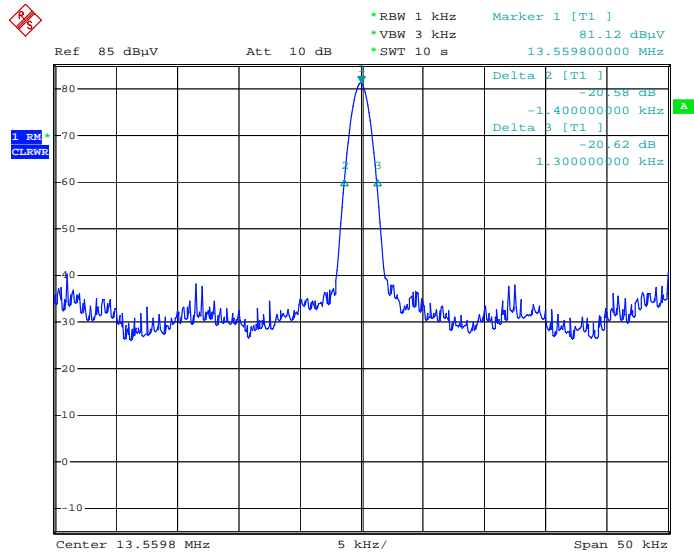

Date: 10.AUG.2009 15:11:51

### Bandwidth of the emission – RF300 Mode, ANT 12

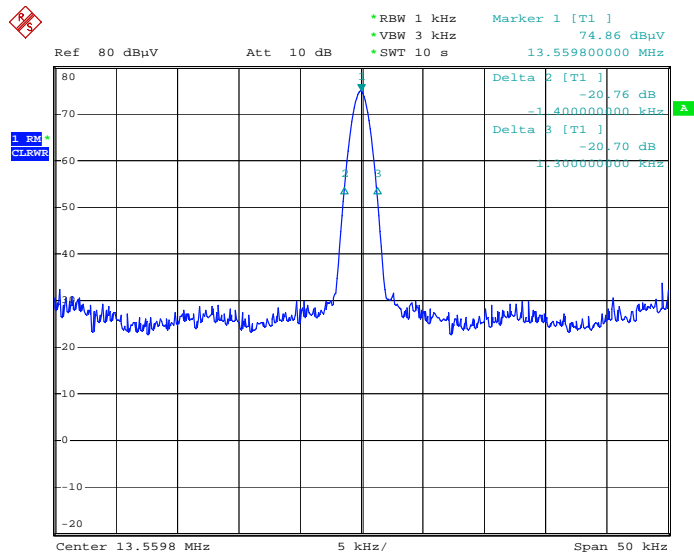

Date: 10.AUG.2009 14:38:06

### Bandwidth of the emission – RF300 Mode, ANT 18

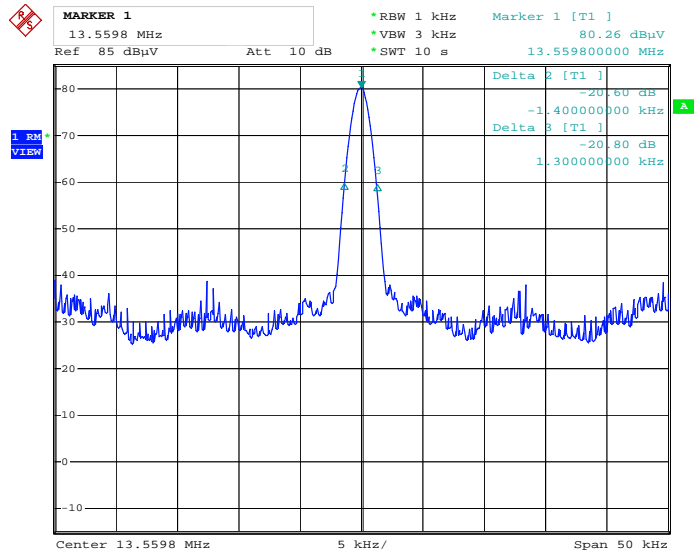

Date: 10.AUG.2009 14:19:10

### Bandwidth of the emission – RF300 Mode, ANT 30

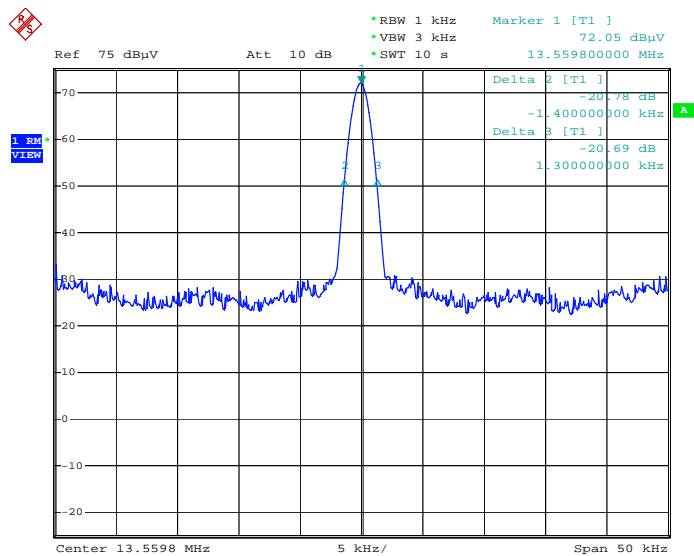

Date: 10.AUG.2009 14:48:08



Permitted frequency band:	<b>13.553 – 13.567 MHz</b>	
20 dB bandwidth:	<b>2.7 kHz</b>	
Carrier frequency stability:	<input checked="" type="checkbox"/> <b>specified</b>	<input type="checkbox"/> <b>not specified</b>
Maximum frequency tolerances:	<b>+0.057 kHz - -0.040kHz</b>	
Bandwidth of the emission:	<b>2.797 kHz</b>	<b>within permitted frequency band<sup>7</sup>:</b> <input checked="" type="checkbox"/> <b>yes</b> <input type="checkbox"/> <b>no</b>

Test Result:	Test passed
--------------	-------------

<sup>7</sup> If a frequency stability is not specified, it is recommended that the fundamental emission is kept within at least the central 80% of the permitted band in order to minimize the possibility of out-of-band operation.

### 7.3 Designation of Emissions

Rules and specifications:	CFR 47 Part 2, sections 2.201 and 2.202 IC RSS-Gen Issue 2, sections 3.2(h) and 8
Guide:	ANSI C63.4 / TRC-43

Type of modulation:	Amplitude Modulation
---------------------	----------------------

$B_n$ = Necessary Bandwidth	$B_n = 2BK$
B = Modulation rate	B = 5 kHz
K = Overall numerical factor	K = 1
Calculation:	$B_n = 2 \cdot (5 \text{ kHz}) \cdot 1 = 10 \text{ kHz}$

Designation of Emissions:	<b>10K0A1D</b>
---------------------------	----------------

## 7.4 Conducted Powerline Emission Measurement 150 kHz to 30 MHz

Rules and specifications:	CFR 47 Part 15, section 15.207 IC RSS-Gen Issue 2, section 7.2.2		
Guide:	ANSI C63.4 / CISPR 22		
Limit:	Frequency of Emission (MHz)	Conducted Limit (dB $\mu$ V)	
		Quasi-peak	Average
	0.15 - 0.5	66 to 56	56 to 46
	0.5 - 5	56	46
	5 - 30	60	50
Measurement procedure:	Conducted AC Powerline Emission (6.3)		

Comment:	With dummy load connected to the antenna output terminals
Date of test:	12 August 2009
Test site:	Shielded room, cabin no. 1

Test Result:	Test passed
--------------	-------------

Tested on: Input of AC Adapter, RF300 Mode

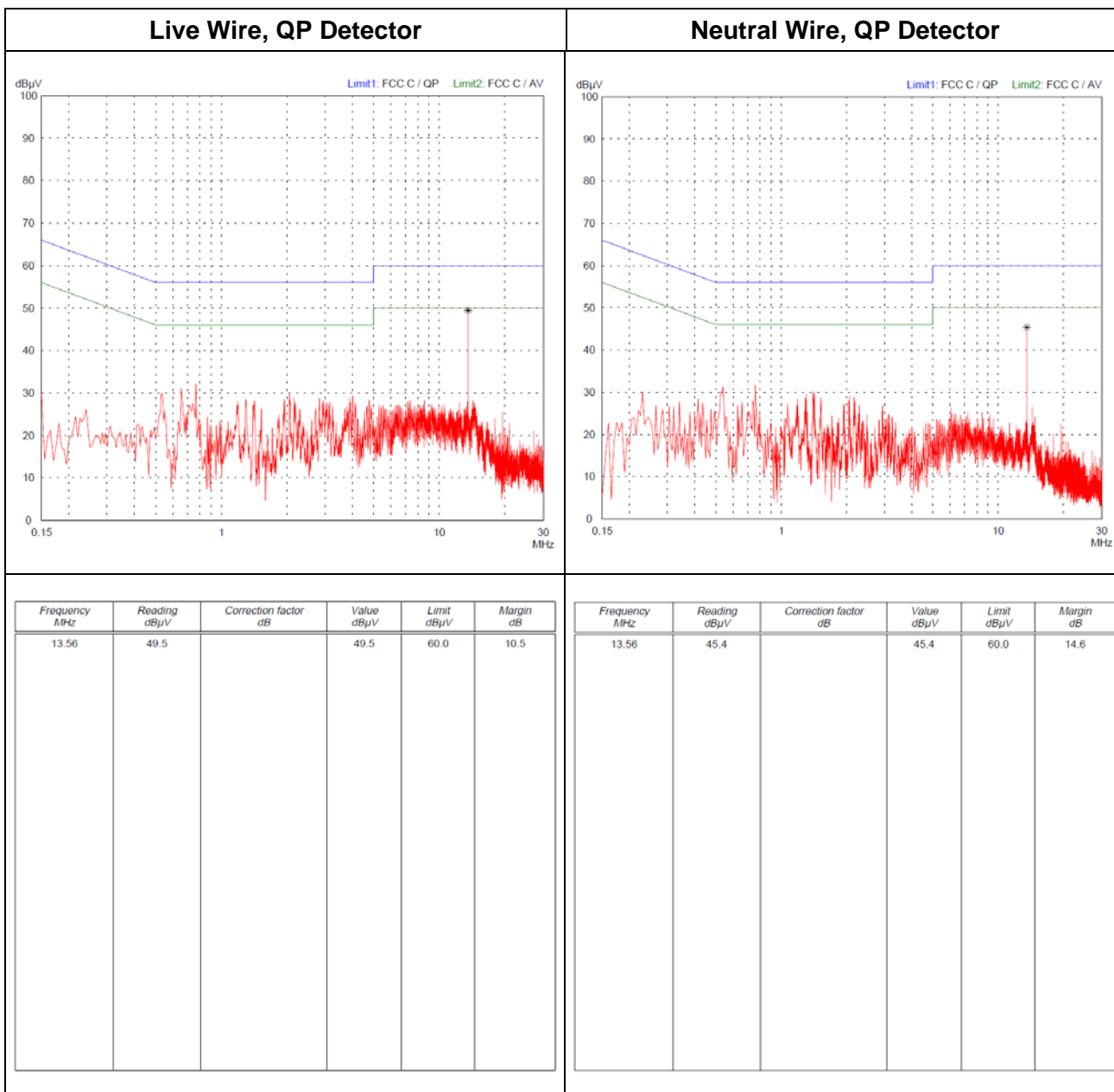

Note: Quasi-Peak results below average limits, retest with average detector omitted



Tested on: Input of AC Adapter, ISO Mode

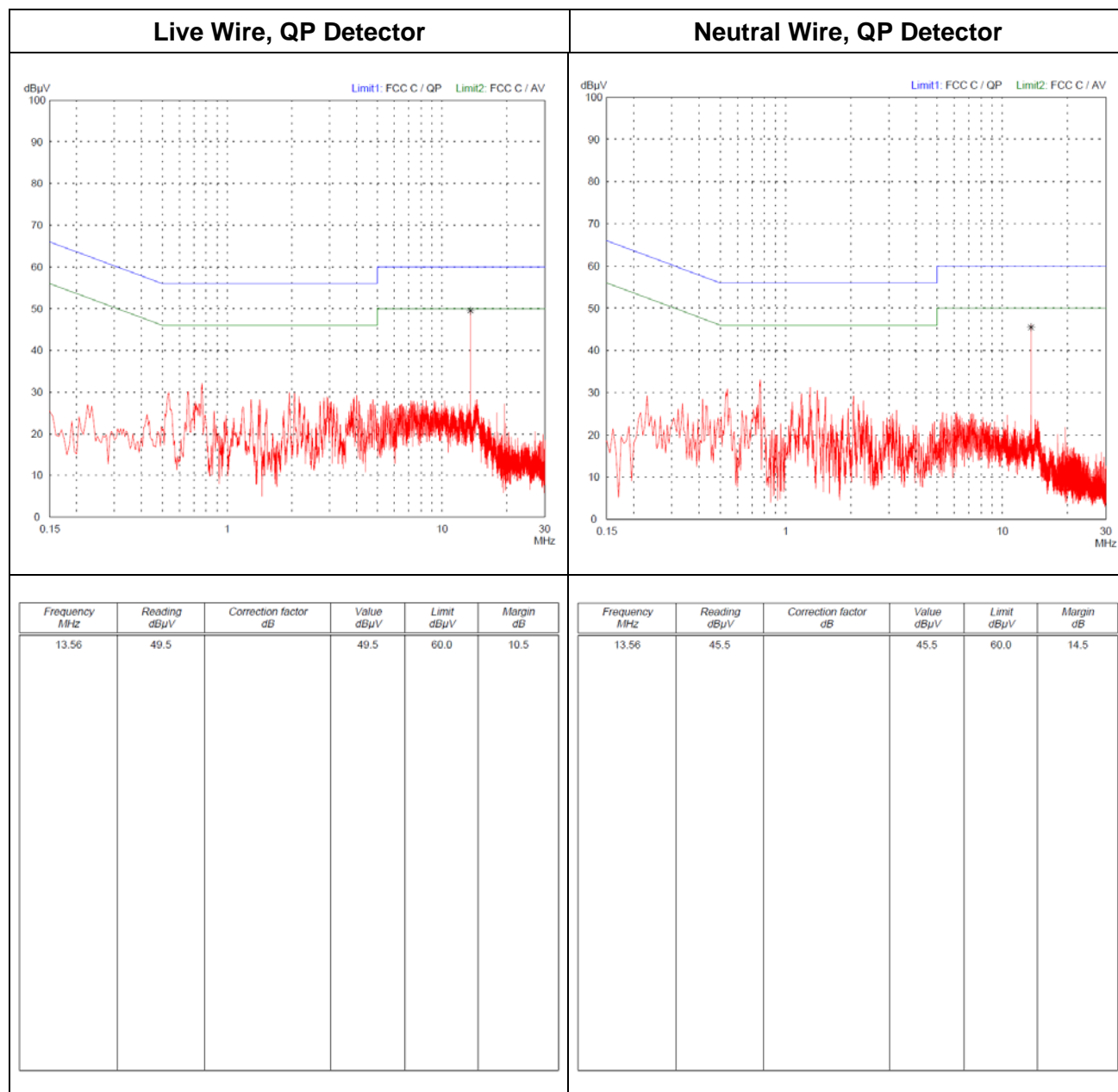

Note: Quasi-Peak results below average limits, retest with average detector omitted

**Sample calculation of final values:**

$$\text{Final Value (dB}\mu\text{V)} = \text{Reading Value (dB}\mu\text{V)} + \text{Correction Factor (dB)}$$



## 7.5 Spectrum Mask

Rules and specifications:	CFR 47 Part 15, section 15.225(a)-(d) IC RSS-210 Issue 7, section A2.6			
Guide:	ANSI C63.4			
Description:	Compliance with the spectrum mask is tested using a spectrum analyzer with resolution bandwidth set to a 1 kHz for the band 13.553 to 13.567 MHz and to 10 kHz outside this band. The video bandwidth shall be at least three times greater than the resolution bandwidth.			
Limit:	Frequency of Emission (MHz)	Field Strength ( $\mu\text{V}/\text{m}$ )	Field Strength ( $\text{dB}\mu\text{V}/\text{m}$ )	Measurement Distance d (meters)
	1.705 - 13.110	30	29.5	30
	13.110 - 13.410	106	40.5	30
	13.410 - 13.553	334	50.5	30
	13.553 - 13.567	15848	84.0	30
	13.567 - 13.710	334	50.5	30
	13.710 - 14.010	106	40.5	30
	14.010 - 30.000	30	29.5	30
Measurement procedure:	Radiated Emission Measurement 9 kHz to 30 MHz (6.4)			

Comment:	
Date of test:	10 August 2009
Test site:	Fully anechoic room, cabin no. 2
Test distance:	3 meters
Extrapolation Factor:	..... dB/decade

Test Result:	Test passed
--------------	-------------

### Spectrum Mask ISO Mode, ANT 1

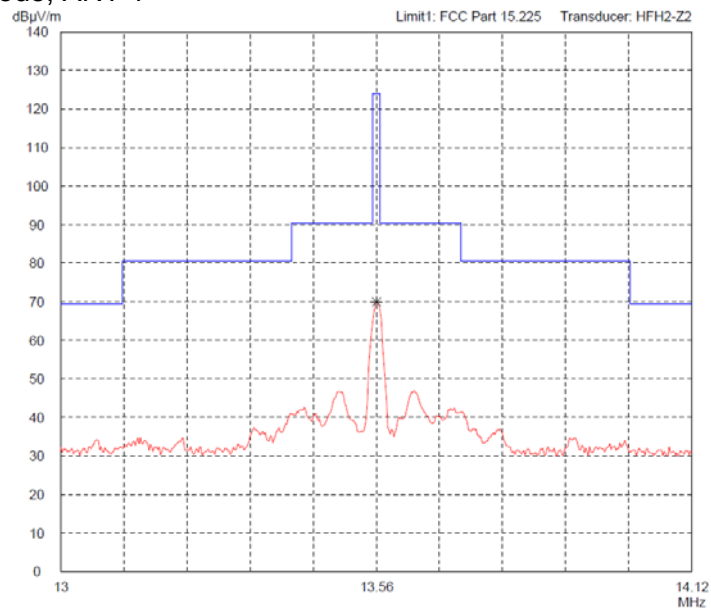

### Spectrum Mask ISO Mode, ANT 12

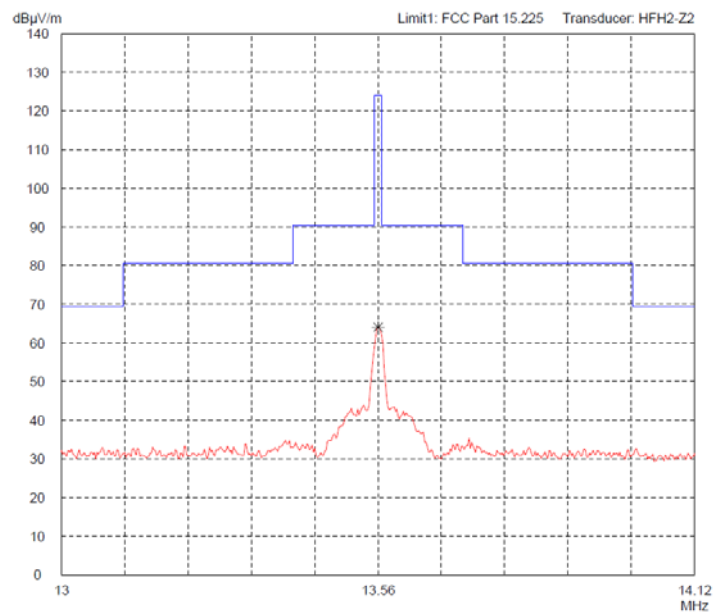

### Spectrum Mask ISO Mode, ANT 18

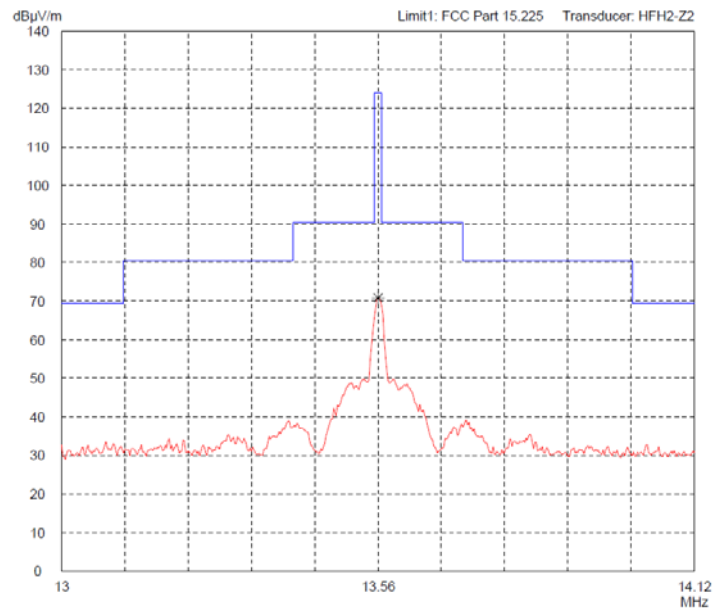

### Spectrum Mask ISO Mode, ANT 30

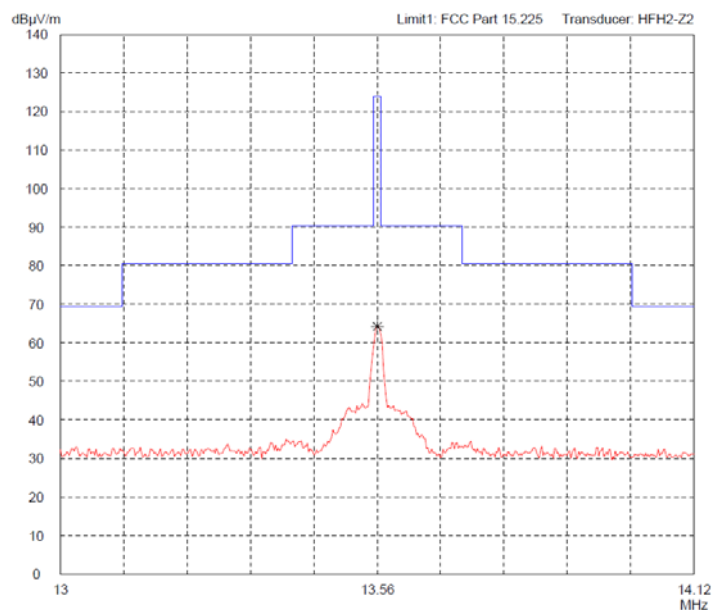

### Spectrum Mask RF300 Mode, ANT 1

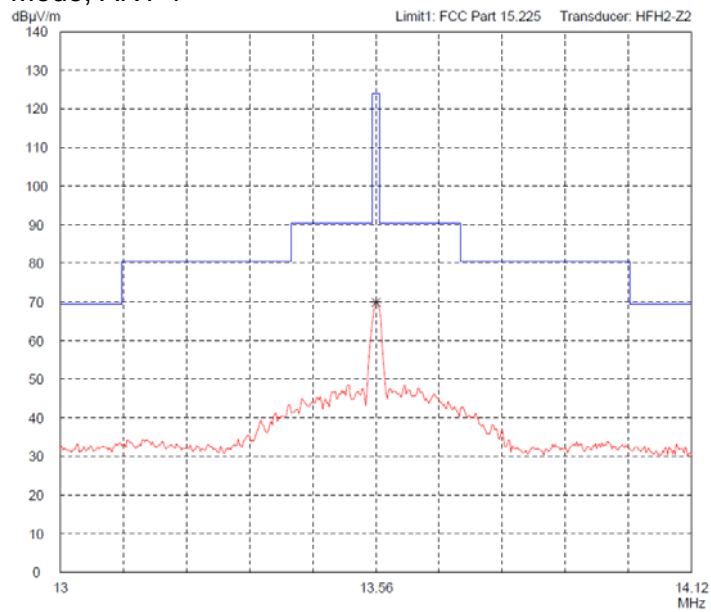

### Spectrum Mask RF300 Mode, ANT 12

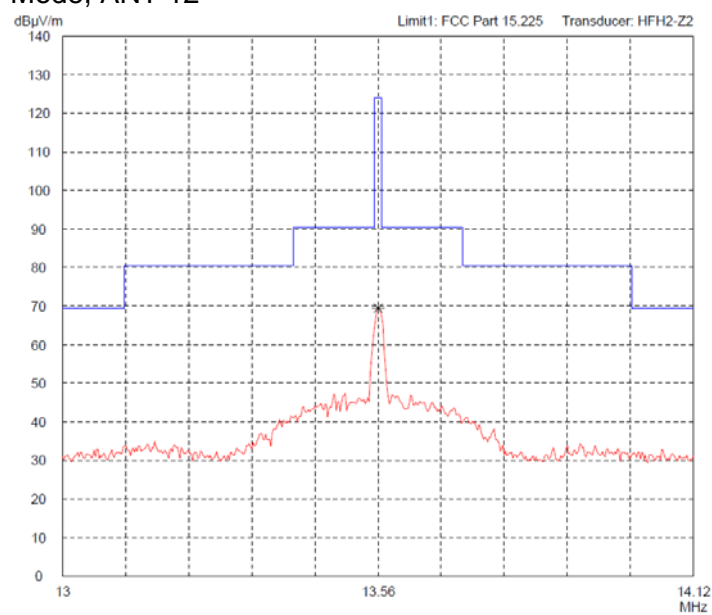

### Spectrum Mask RF300 Mode, ANT 18

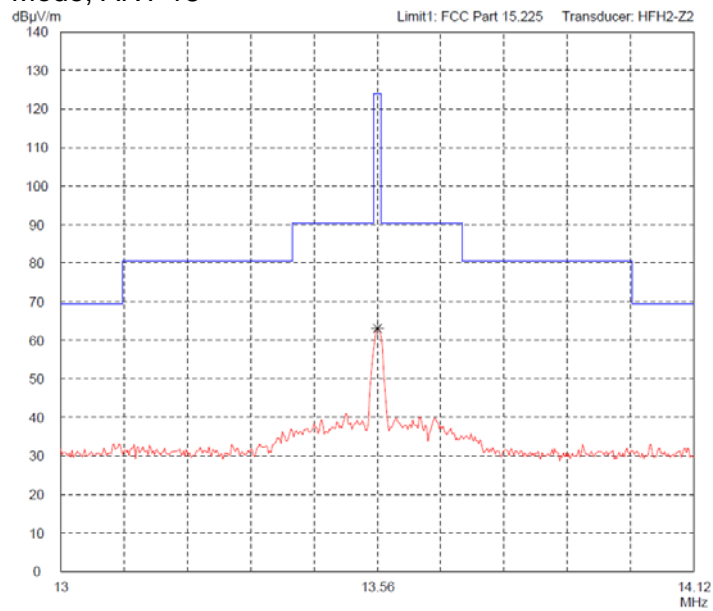

### Spectrum Mask RF300 Mode, ANT 30

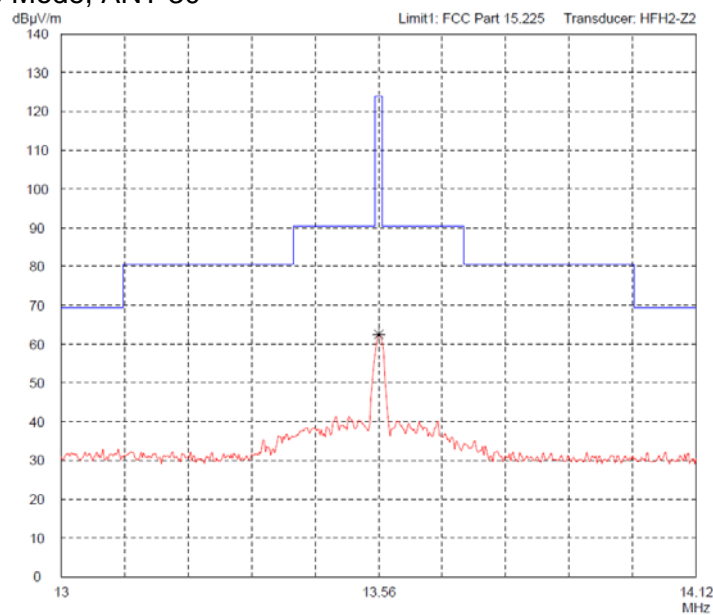

## 7.6 Radiated Emission Measurement 9 kHz to 30 MHz

Rules and specifications:	CFR 47 Part 15, sections 15.205 and 15.225(a)-(d) IC RSS-210 Issue 7, sections 2.2(b)(c), 2.6 and A2.6			
Guide:	ANSI C63.4			
Limit:	Frequency of Emission (MHz)	Field Strength ( $\mu\text{V}/\text{m}$ )	Field Strength ( $\text{dB}\mu\text{V}/\text{m}$ )	Measurement Distance d (meters)
	0.009 - 0.490	2400/F(kHz)	67.6 - 20 · log(F(kHz))	300
	0.490 - 1.705	24000/F(kHz)	87.6 - 20 · log(F(kHz))	30
	1.705 - 13.110	30	29.5	30
	13.110 - 13.410	106	40.5	30
	13.410 - 13.553	334	50.5	30
	13.553 - 13.567	15848	84.0	30
	13.567 - 13.710	334	50.5	30
	13.710 - 14.010	106	40.5	30
	14.010 - 30.000	30	29.5	30
Additionally, the level of any unwanted emissions shall not exceed the level of the fundamental emission.				
Measurement procedure:	Radiated Emission Measurement 9 kHz to 30 MHz (6.4)			

Comment:	
Date of test:	
Test site:	Open field test site

Test Result:	Test passed
--------------	-------------

### ISO Mode ANT 1

Extrapolation factor: -40 dB/decade										
Frequency (MHz)	Detector	Distance		Reading Value (dB $\mu$ V)	Correction Factor (dB/m)	Extrapolation Factor (dB)	Pulse Train Correction (dB)	Final Value (dB $\mu$ V/m)	Limit (dB $\mu$ V/m)	Margin (dB)
		d1 (m)	d (m)							
13.56000	Quasi-Peak	10	30	34.9	20.0	-19.1		35.8	84.0	<b>48.2</b>

### RF300 Mode ANT 1

Extrapolation factor: -40 dB/decade										
Frequency (MHz)	Detector	Distance		Reading Value (dB $\mu$ V)	Correction Factor (dB/m)	Extrapolation Factor (dB)	Pulse Train Correction (dB)	Final Value (dB $\mu$ V/m)	Limit (dB $\mu$ V/m)	Margin (dB)
		d1 (m)	d (m)							
13.56000	Quasi-Peak	10	30	34.0	20.0	-19.1		34.9	84.0	<b>49.1</b>

### ISO Mode ANT 12

Extrapolation factor: -40 dB/decade										
Frequency (MHz)	Detector	Distance		Reading Value (dB $\mu$ V)	Correction Factor (dB/m)	Extrapolation Factor (dB)	Pulse Train Correction (dB)	Final Value (dB $\mu$ V/m)	Limit (dB $\mu$ V/m)	Margin (dB)
		d1 (m)	d (m)							
13.56000	Quasi-Peak	10	30	29.5	20.0	-19.1		30.4	84.0	<b>53.6</b>

### RF300 Mode ANT 12

Extrapolation factor: -40 dB/decade										
Frequency (MHz)	Detector	Distance		Reading Value (dB $\mu$ V)	Correction Factor (dB/m)	Extrapolation Factor (dB)	Pulse Train Correction (dB)	Final Value (dB $\mu$ V/m)	Limit (dB $\mu$ V/m)	Margin (dB)
		d1 (m)	d (m)							
13.56000	Quasi-Peak	10	30	29.0	20.0	-19.1		29.9	84.0	<b>54.1</b>





### ISO Mode ANT 18

Extrapolation factor: -40 dB/decade										
Frequency (MHz)	Detector	Distance		Reading Value (dBµV)	Correction Factor (dB/m)	Extrapolation Factor (dB)	Pulse Train Correction (dB)	Final Value (dBµV/m)	Limit (dBµV/m)	Margin (dB)
		d1 (m)	d (m)							
13.56000	Quasi-Peak	10	30	35.9	20.0	-19.1		36.8	84.0	<b>47.2</b>

### RF300 Mode ANT 18

Extrapolation factor: -40 dB/decade										
Frequency (MHz)	Detector	Distance		Reading Value (dBµV)	Correction Factor (dB/m)	Extrapolation Factor (dB)	Pulse Train Correction (dB)	Final Value (dBµV/m)	Limit (dBµV/m)	Margin (dB)
		d1 (m)	d (m)							
13.56000	Quasi-Peak	10	30	34.9	20.0	-19.1		35.8	84.0	<b>48.2</b>

### ISO Mode ANT 30

Extrapolation factor: -40 dB/decade										
Frequency (MHz)	Detector	Distance		Reading Value (dBµV)	Correction Factor (dB/m)	Extrapolation Factor (dB)	Pulse Train Correction (dB)	Final Value (dBµV/m)	Limit (dBµV/m)	Margin (dB)
		d1 (m)	d (m)							
13.56000	Quasi-Peak	10	30	30.6	20.0	-19.1		31.5	84.0	<b>52.5</b>

### RF300 Mode ANT 30

Extrapolation factor: -40 dB/decade										
Frequency (MHz)	Detector	Distance		Reading Value (dBµV)	Correction Factor (dB/m)	Extrapolation Factor (dB)	Pulse Train Correction (dB)	Final Value (dBµV/m)	Limit (dBµV/m)	Margin (dB)
		d1 (m)	d (m)							
13.56000	Quasi-Peak	10	30	28.2	20.0	-19.1		29.1	84.0	<b>54.9</b>

**Sample calculation of final values:**

$$\begin{aligned} \text{Extrapolation Factor (dB)} &= (\text{Log}(d) - \text{Log}(d_1)) \cdot \text{Extrapolation Factor (dB/decade)} \\ \text{Final Value (dB}\mu\text{V/m)} &= \text{Reading Value } d_1 \text{ (dB}\mu\text{V)} + \text{Correction Factor (dB/m)} \\ &\quad + \text{Extrapolation Factor (dB)} + \text{Pulse Train Correction (dB)} \end{aligned}$$

Note: Extrapolation factor (dB) and final value (dB $\mu$ V/m) are relating to distance d.

**Sample calculation of final values:**

$$\text{Extrapolation Factor (dB/decade)} \left\{ \begin{array}{ll} -40 \text{ (dB/decade)} & \text{if } d_1 = d_2 \\ \frac{\text{Reading Value } d_2 \text{ (dB}\mu\text{V)} - \text{Reading Value } d_1 \text{ (dB}\mu\text{V)}}{\text{Log}(d_2) - \text{Log}(d_1)} & \text{if } d_1 \neq d_2 \end{array} \right.$$

$$\begin{aligned} \text{Extrapolation Factor (dB)} &= (\text{Log}(d) - \text{Log}(d_2)) \cdot \text{Extrapolation Factor (dB/decade)} \\ \text{Final Value (dB}\mu\text{V/m)} &= \text{Reading Value } d_2 \text{ (dB}\mu\text{V)} + \text{Correction Factor (dB/m)} \\ &\quad + \text{Extrapolation Factor (dB)} + \text{Pulse Train Correction (dB)} \end{aligned}$$

Note: Extrapolation factor (dB) and final value (dB $\mu$ V/m) are relating to distance d.

**Prescan in fully-anechoic chamber at 3 m test distance – ISO Mode**

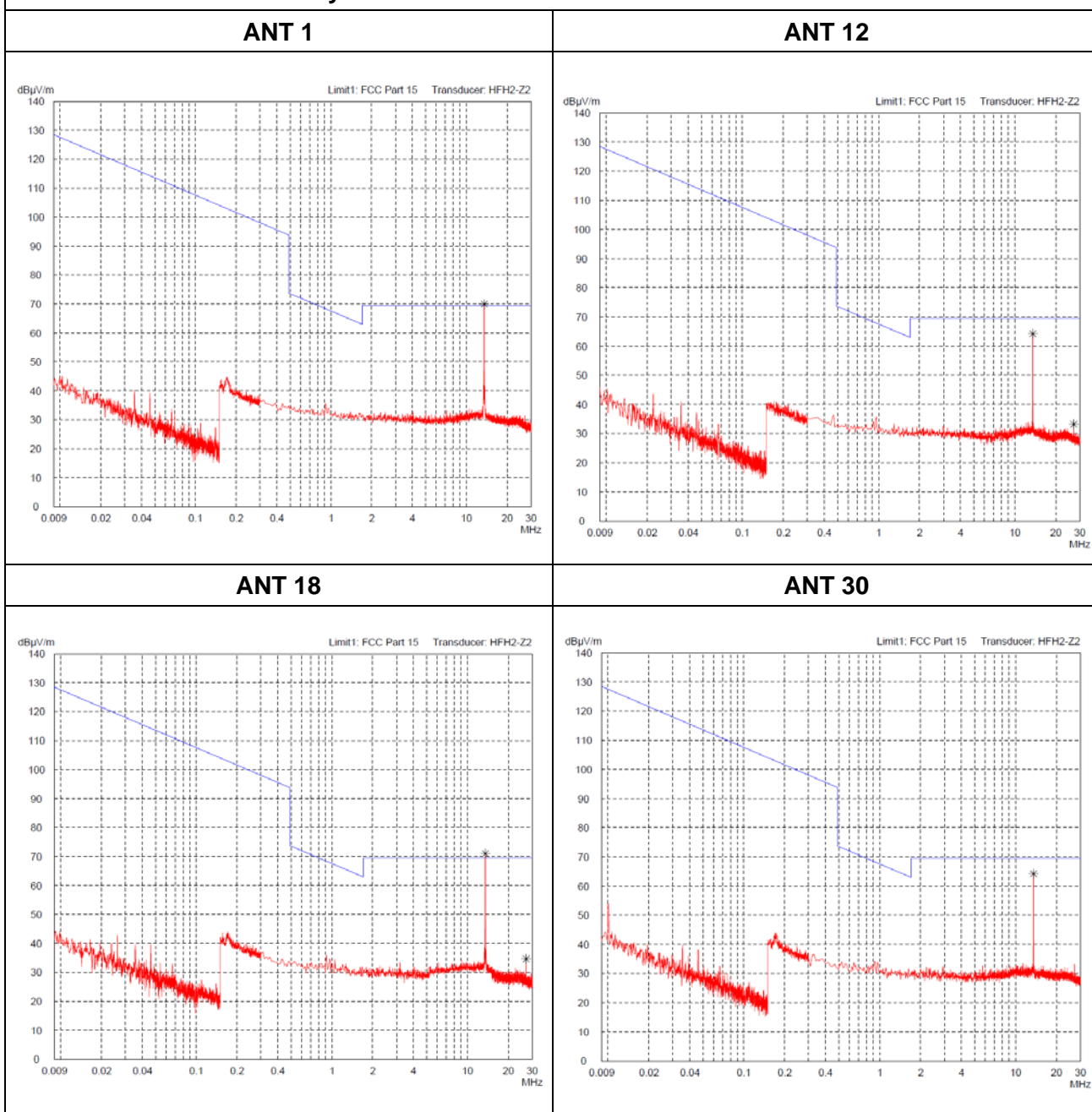

**Prescan in fully-anechoic chamber at 3 m test distance – RF300 Mode**

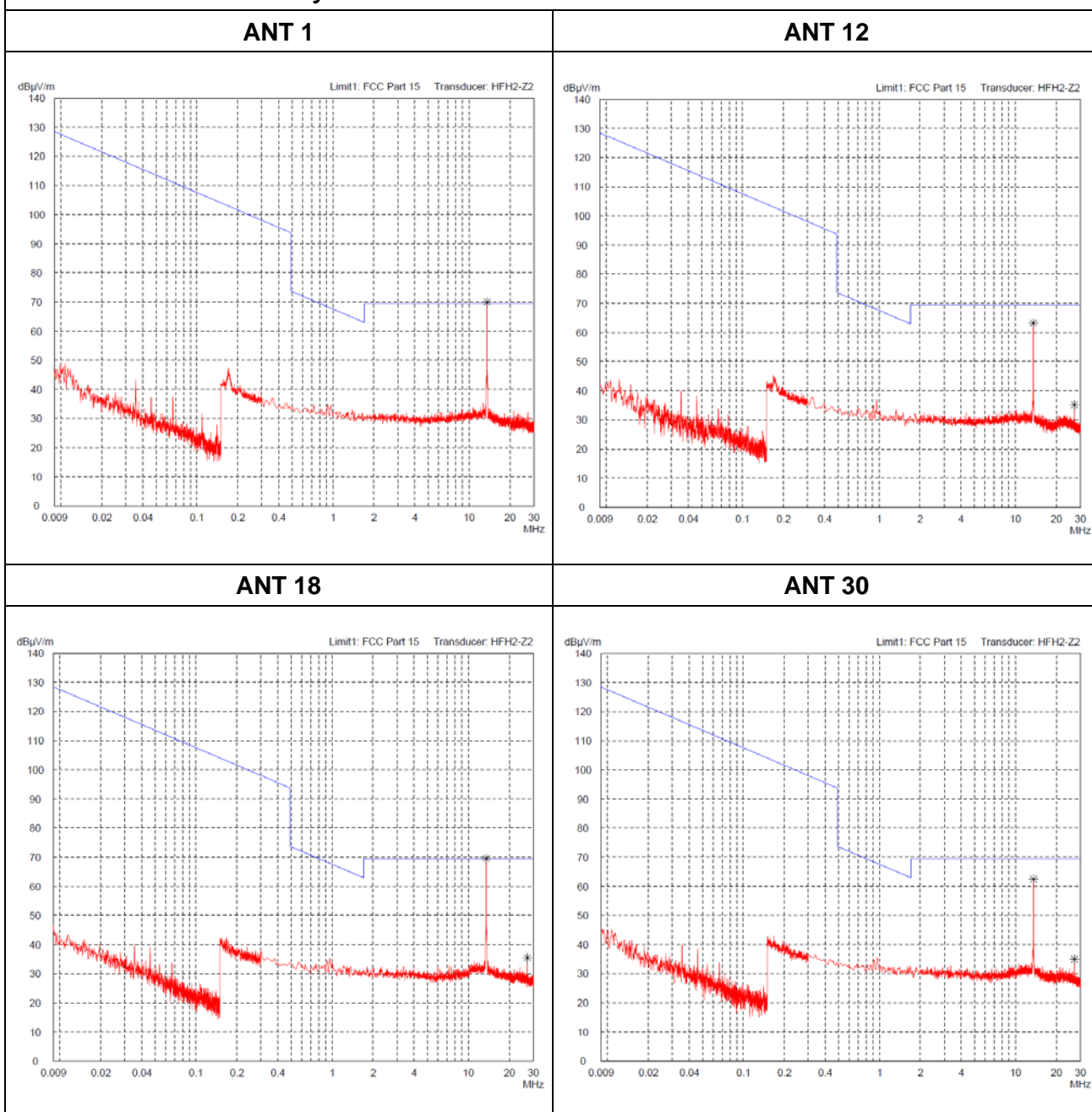

## 7.7 Radiated Emission Measurement 30 MHz to 1 GHz

Rules and specifications:	CFR 47 Part 15, sections 15.205(b) and 15.225(d) IC RSS-210 Issue 7, sections 2.2(b)(c), 2.6 and A2.6		
Guide:	ANSI C63.4		
Limit:	Frequency of Emission (MHz)	Field Strength ( $\mu\text{V}/\text{m}$ )	Field Strength ( $\text{dB}\mu\text{V}/\text{m}$ )
	30 - 88	100	40.0
	88 - 216	150	43.5
	216 - 960	200	46.0
	Above 960	500	54.0
	Additionally, the level of any unwanted emissions shall not exceed the level of the fundamental emission.		
Measurement procedures:	Radiated Emission in Fully or Semi Anechoic Room (6.5) Radiated Emission at Open Field Test Site (6.6)		

Comment:	
Date of test:	07 August 2009
Test site:	Frequencies $\leq$ 1 GHz: Open field test site Frequencies $>$ 1 GHz: Fully anechoic room, cabin no. 2
Test distance:	3 meters

Test Result:	Test passed
--------------	-------------

**ISO Mode, ANT 1**

**Prescan in fully-anechoic chamber with peak detector**

**Horizontal polarisation**

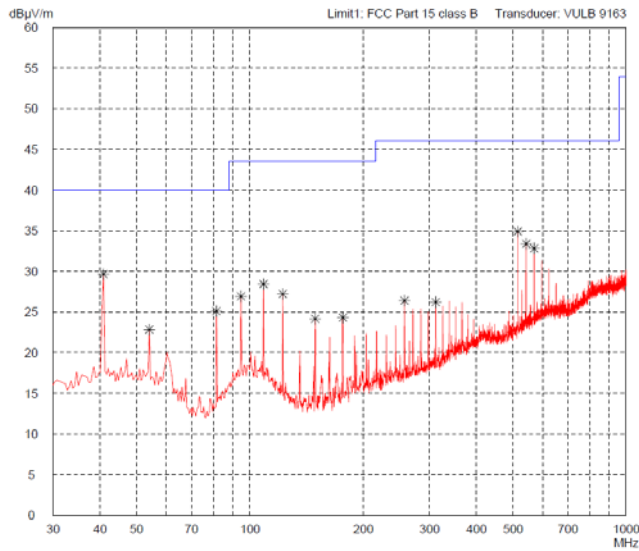

**Vertical polarisation**

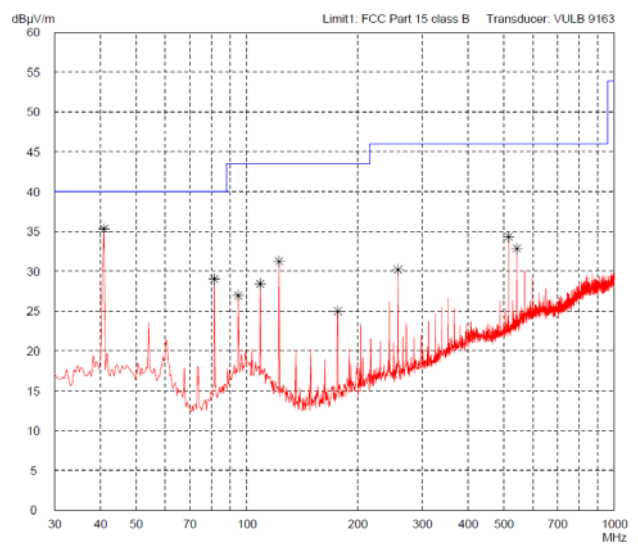

**Final test on OATS with quasi peak detector**

**Horizontal polarisation**

Frequency MHz	Reading dBµV	Correction factor dB	Value dBµV/m	Limit dBµV/m	Margin dB
40.687	12.5	11.7	24.2	40.0	15.8
54.240	11.8	10.0	21.8	40.0	18.2
67.800	12.3	9.6	21.9	40.0	18.1
81.360	20.5	9.7	30.2	40.0	9.8
94.920	17.2	10.4	27.6	43.5	15.9
108.480	15.9	11.5	27.4	43.5	16.1
122.040	18.3	12.5	30.8	43.5	12.7
135.600	11.5	13.3	24.8	43.5	18.7
149.160	5.6	13.8	19.4	43.5	24.1
162.720	2.4	14.3	16.7	43.5	26.8
176.280	6.4	15.0	21.4	43.5	22.1
203.400	11.7	16.8	28.3	43.5	15.2
216.960	9.5	16.8	26.3	46.0	19.7
230.520	6.2	17.1	23.3	46.0	22.7
244.080	6.3	17.6	23.9	46.0	22.1
284.760	7.5	20.3	27.8	46.0	18.2
298.320	4.0	21.8	25.8	46.0	20.2
311.880	12.3	15.9	28.2	46.0	17.8
325.440	8.5	16.4	24.9	46.0	21.1
339.000	5.7	16.9	22.6	46.0	23.4
352.560	7.3	17.3	24.6	46.0	21.4
366.120	7.2	17.5	24.7	46.0	21.3
542.400	4.5	21.6	26.1	46.0	19.9
596.640	6.5	22.7	29.2	46.0	16.8

**Vertical polarisation**

Frequency MHz	Reading dBµV	Correction factor dB	Value dBµV/m	Limit dBµV/m	Margin dB
40.68	23.3	11.7	35.0	40.0	5.0
54.24	16.7	10.0	26.7	40.0	13.3
67.80	20.6	9.6	30.2	40.0	9.8
81.36	26.0	9.7	35.7	40.0	4.3
94.92	19.7	10.4	30.1	43.5	13.4
108.48	12.7	11.5	24.2	43.5	19.3
122.04	17.6	12.5	30.1	43.5	13.4
135.60	12.3	13.3	25.6	43.5	17.9
149.16	8.0	13.8	21.8	43.5	21.7
176.28	8.7	15.0	23.7	43.5	19.8
203.40	5.9	16.6	22.5	43.5	21.0
216.96	7.8	16.8	24.6	46.0	21.4
244.08	3.2	17.6	20.8	46.0	25.2
325.44	8.1	16.4	24.5	46.0	21.5
339.00	7.3	16.9	24.2	46.0	21.8
488.16	5.4	20.7	26.1	46.0	19.9
515.28	13.2	21.2	34.4	46.0	11.6
542.40	6.9	21.6	28.5	46.0	17.5

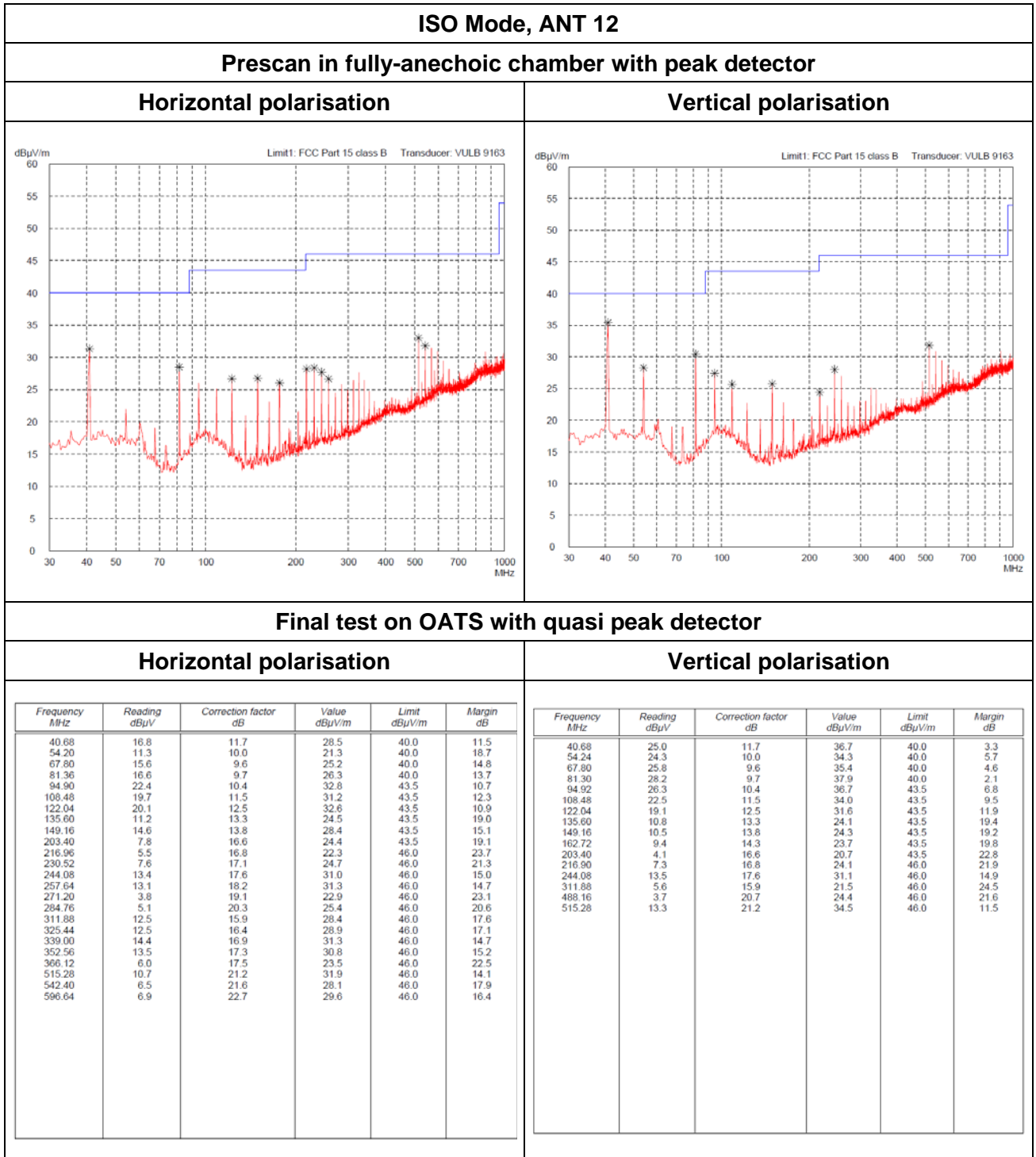

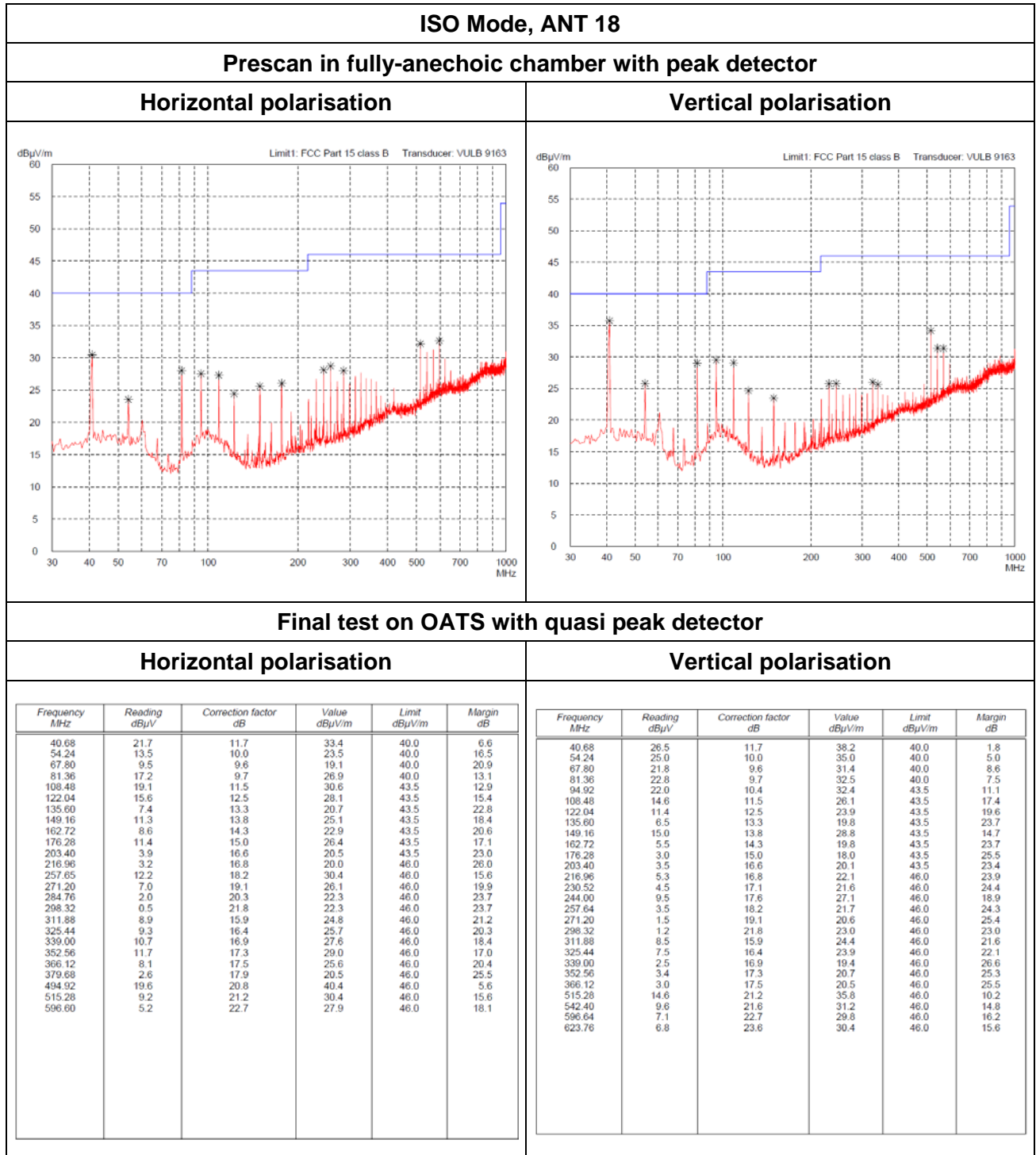



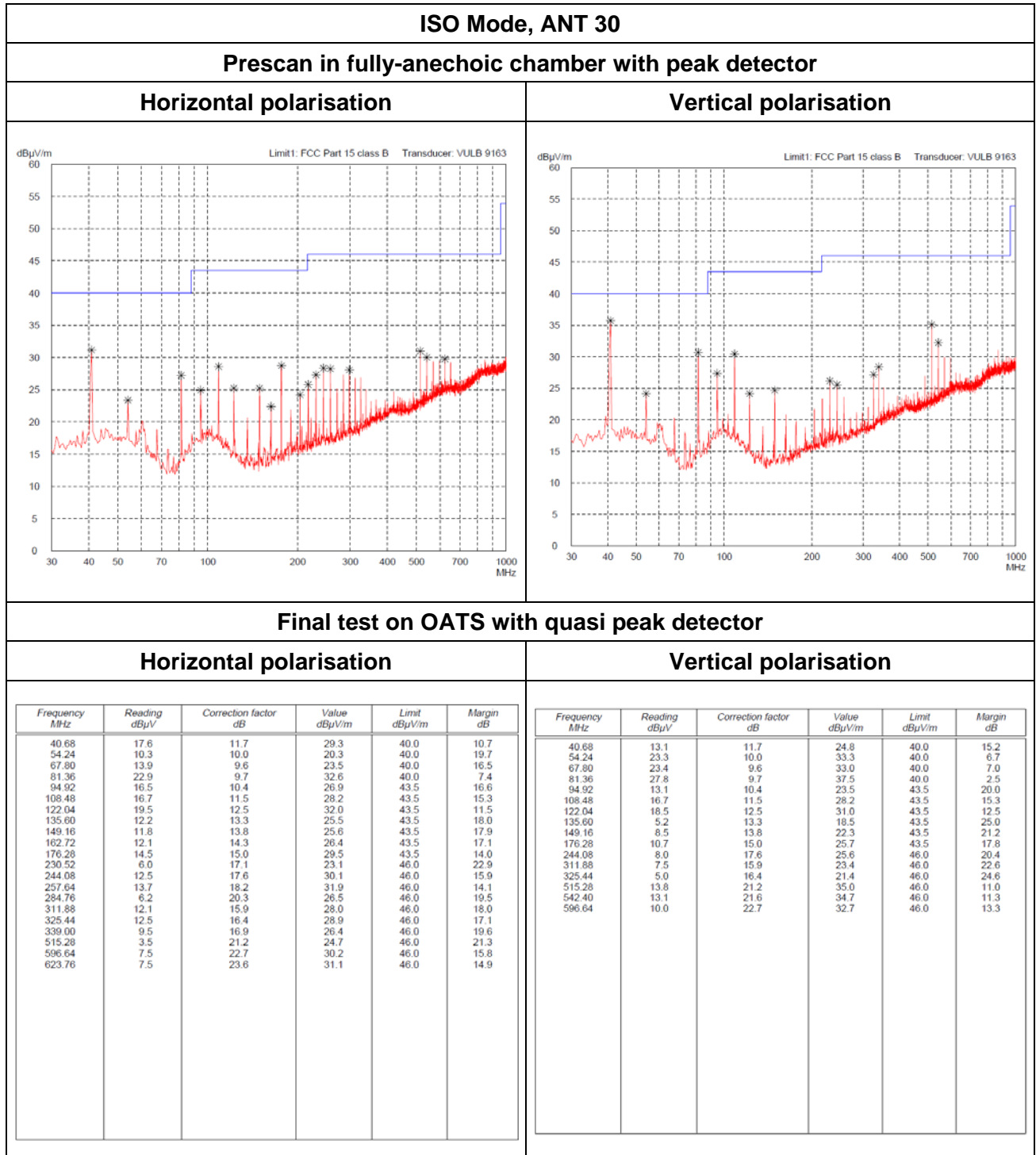

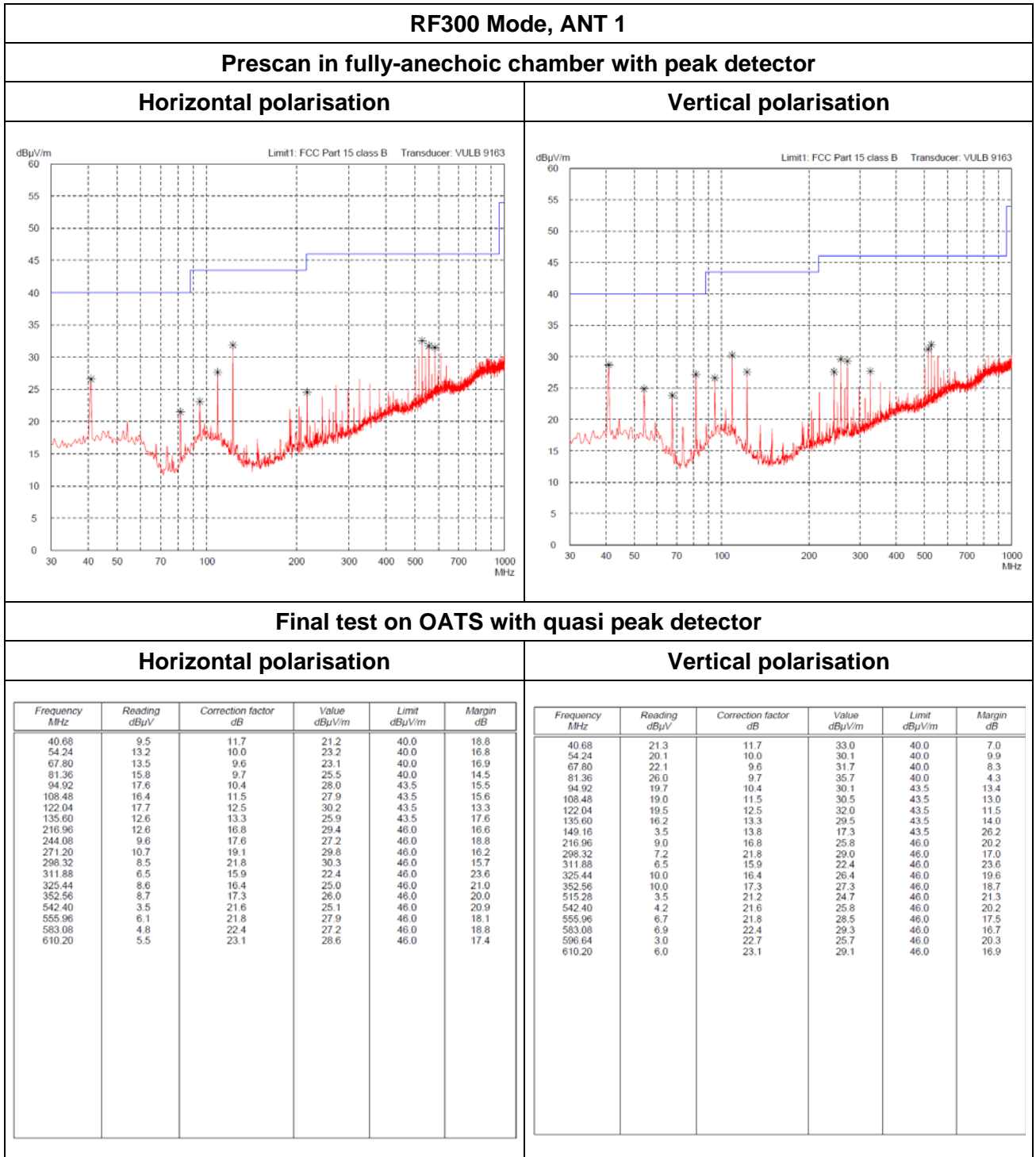

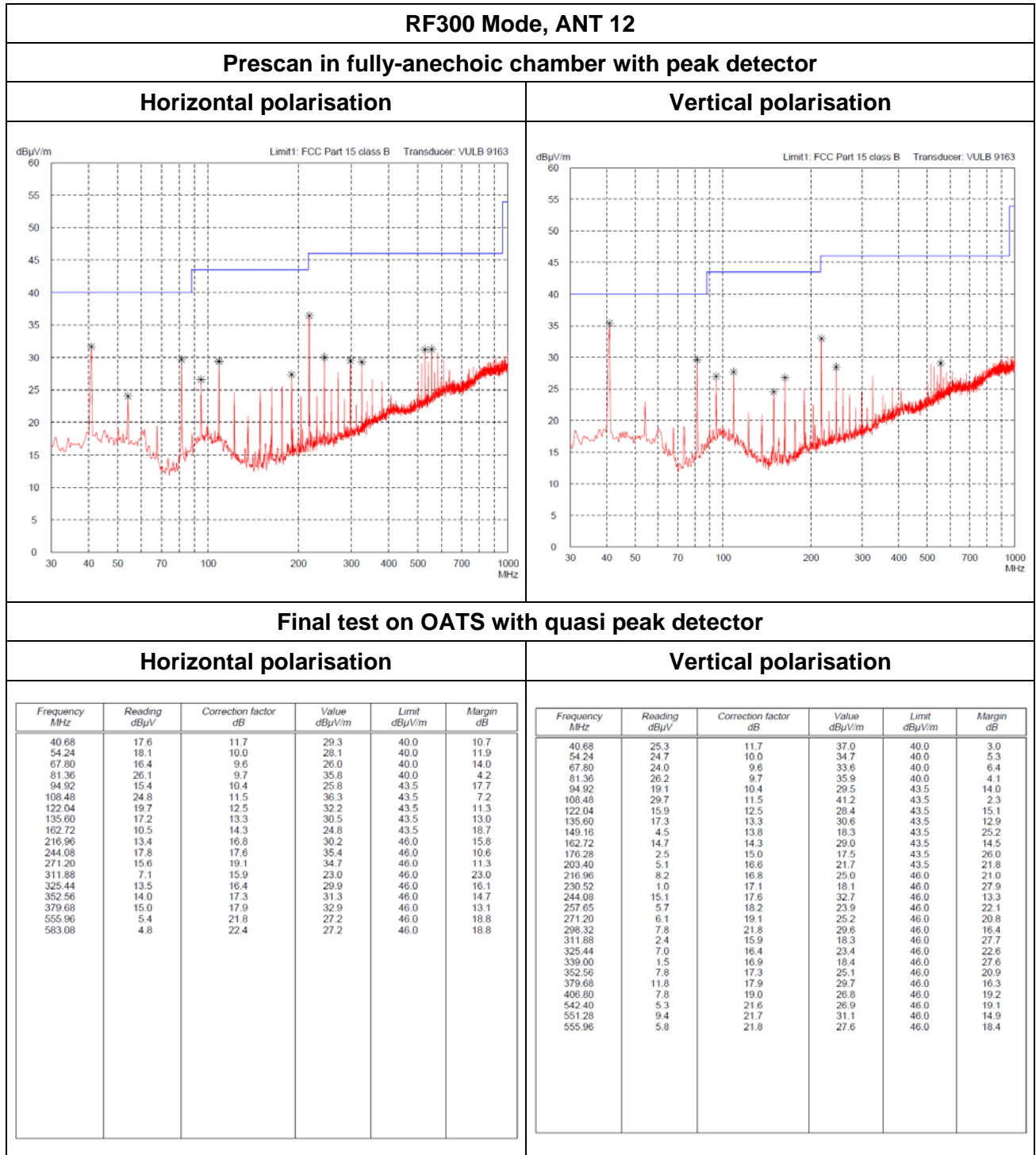

**RF300 Mode, ANT 18**

**Prescan in fully-anechoic chamber with peak detector**

**Horizontal polarisation**

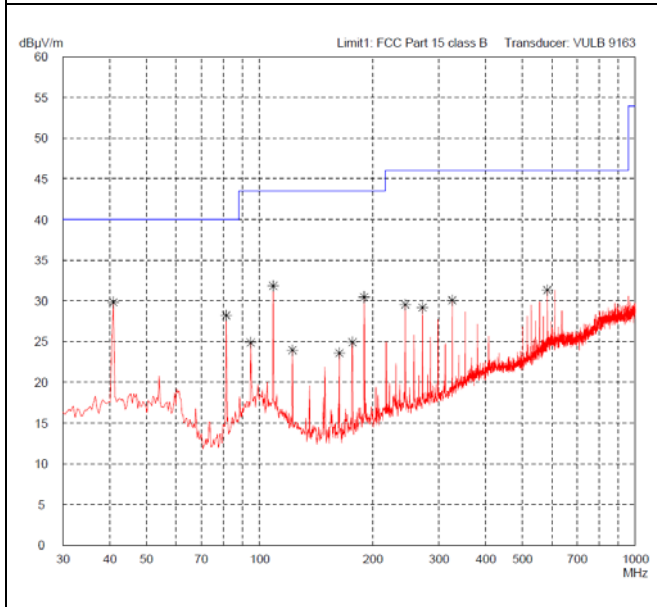

**Vertical polarisation**

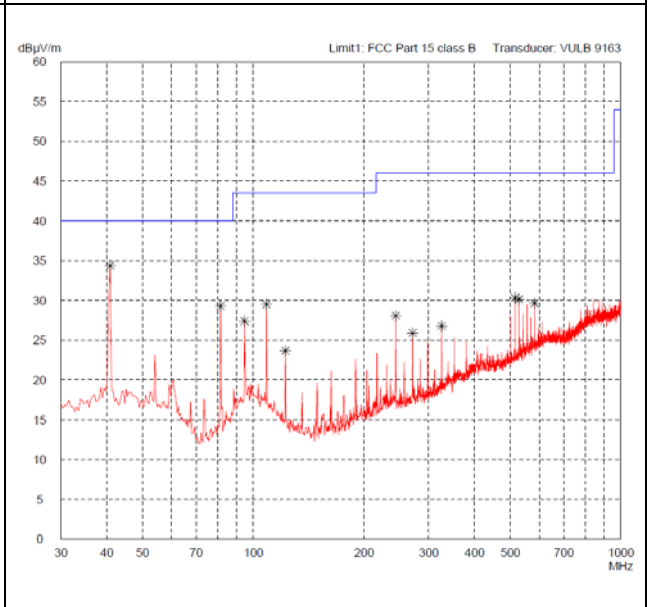

**Final test on OATS with quasi peak detector**

**Horizontal polarisation**

Frequency MHz	Reading dBµV	Correction factor dB	Value dBµV/m	Limit dBµV/m	Margin dB
40.68	16.5	11.7	28.2	40.0	11.8
54.24	11.7	10.0	21.7	40.0	18.3
67.80	11.1	9.6	20.7	40.0	19.3
81.36	15.3	9.7	25.0	40.0	15.0
94.92	13.7	10.4	24.1	43.5	19.4
108.48	23.8	11.5	35.3	43.5	8.2
122.04	9.5	12.5	22.0	43.5	21.5
135.60	5.8	13.3	19.1	43.5	24.4
149.16	4.8	13.8	18.6	43.5	24.9
162.72	4.4	14.3	18.7	43.5	24.8
176.28	3.4	15.0	18.4	43.5	25.1
203.40	3.6	16.6	20.2	43.5	23.3
216.96	5.9	16.8	22.7	46.0	23.3
244.08	12.8	17.6	30.4	46.0	15.6
257.64	11.6	18.2	29.8	46.0	16.2
271.20	14.6	19.1	33.7	46.0	12.3
311.88	4.5	15.9	20.4	46.0	25.6
325.44	13.4	16.4	29.8	46.0	16.2
352.56	12.7	17.3	30.0	46.0	16.0
366.12	2.1	17.5	19.6	46.0	26.4
379.68	8.3	17.9	26.2	46.0	19.8
406.80	3.5	19.0	22.5	46.0	23.5
501.72	4.8	21.0	25.8	46.0	20.2
515.28	4.8	21.2	26.0	46.0	20.0
555.96	2.7	21.8	24.5	46.0	21.5
583.08	4.8	22.4	27.2	46.0	18.8

**Vertical polarisation**

Frequency MHz	Reading dBµV	Correction factor dB	Value dBµV/m	Limit dBµV/m	Margin dB
40.68	22.5	11.7	34.2	40.0	5.8
54.24	17.8	10.0	27.8	40.0	12.2
67.80	15.8	9.6	25.4	40.0	14.6
81.36	26.5	9.7	36.2	40.0	3.8
94.92	18.5	10.4	28.9	43.5	14.6
108.48	19.3	11.5	30.8	43.5	12.7
122.04	14.2	12.5	26.7	43.5	16.8
135.60	10.9	13.3	24.2	43.5	19.3
149.16	6.0	13.8	19.8	43.5	23.7
176.28	5.4	15.0	20.4	43.5	23.1
203.40	3.5	16.6	20.1	43.5	23.4
216.96	7.5	16.8	24.3	46.0	21.7
230.52	3.5	17.1	20.6	46.0	25.4
244.08	14.4	17.6	32.0	46.0	14.0
257.64	4.5	18.2	22.7	46.0	23.3
271.20	7.0	19.1	26.1	46.0	19.9
284.76	2.3	20.3	22.6	46.0	23.4
298.32	3.5	21.8	25.3	46.0	20.7
311.88	3.5	15.9	19.4	46.0	26.6
325.44	7.8	16.4	24.2	46.0	21.8
339.00	1.5	16.9	18.4	46.0	27.6
352.56	6.8	17.3	24.1	46.0	21.9
379.68	2.8	17.9	20.7	46.0	25.3
501.72	6.2	21.0	27.2	46.0	18.8
515.28	10.6	21.2	31.8	46.0	14.2
542.40	8.9	21.8	30.5	46.0	15.5
555.96	10.0	21.8	31.8	46.0	14.2
583.08	10.0	22.4	32.4	46.0	13.6
596.64	2.5	22.7	25.2	46.0	20.8

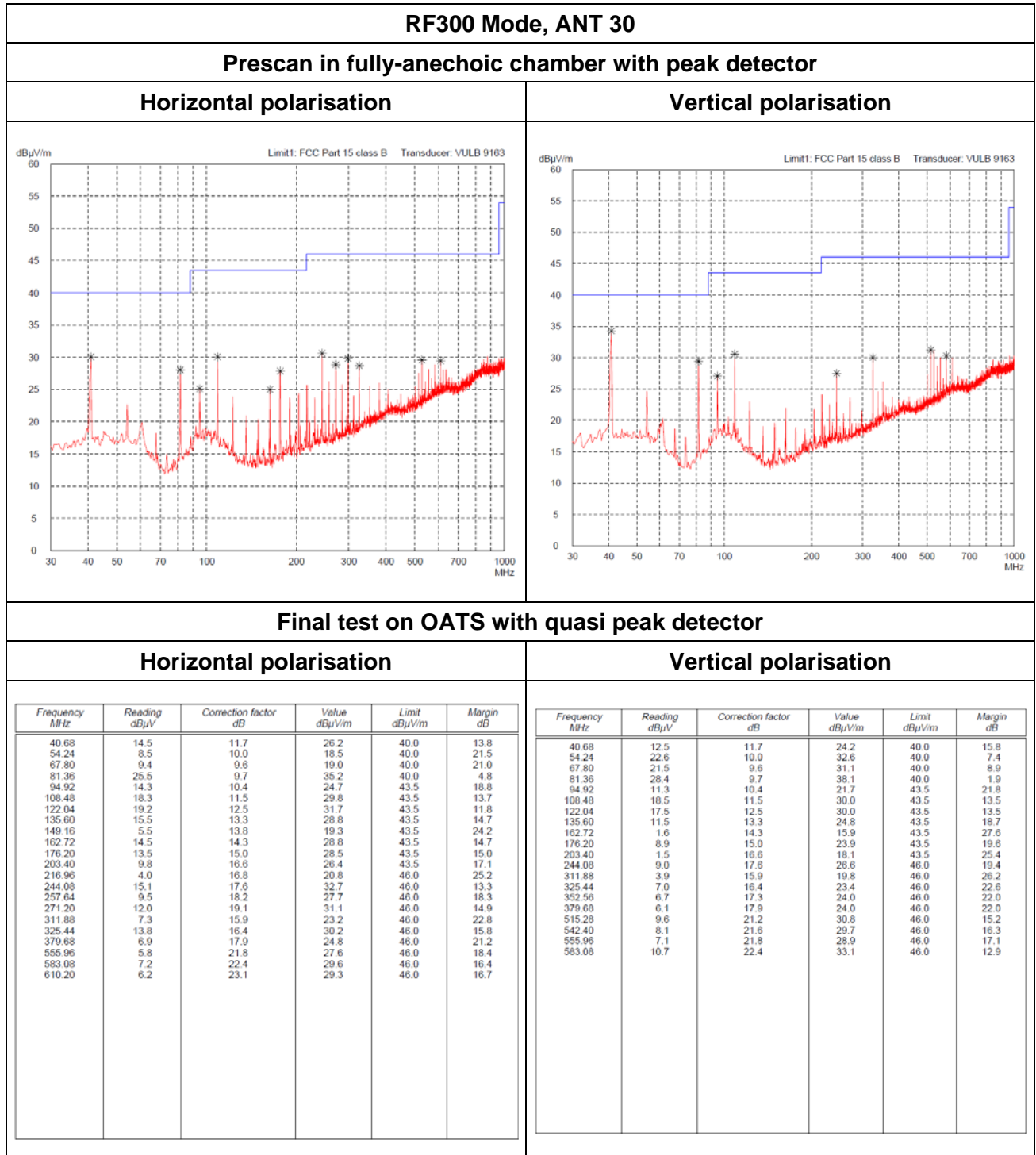

**Sample calculation of final values:**

$$\text{Final Value (dBµV/m)} = \text{Reading Value (dBµV)} + \text{Correction Factor (dB/m)} + \text{Pulse Train Correction (dB)}$$

## 7.8 Carrier Frequency Stability

Rules and specifications:	CFR 47 Part 15, section 15.225(e) IC RSS-Gen Issue 2, section 4.7 and IC RSS-210 Issue 7, section A2.6
Guide:	ANSI C63.4
Limit:	The frequency tolerance of the carrier signal shall be maintained within $\pm 0.01\%$ ( $\pm 100$ ppm) of the carrier frequency under nominal conditions.
Temperature range:	-20°C to +50°C (at normal supply voltage)
Voltage range:	85% to 115% of the rated supply voltage (at a temperature of +20°C)
Measurement procedure:	Carrier Frequency Stability (6.7)

Comment:

Date of test:

## 7.8.1 Carrier Frequency Stability vs. Temperature

### ISO mode

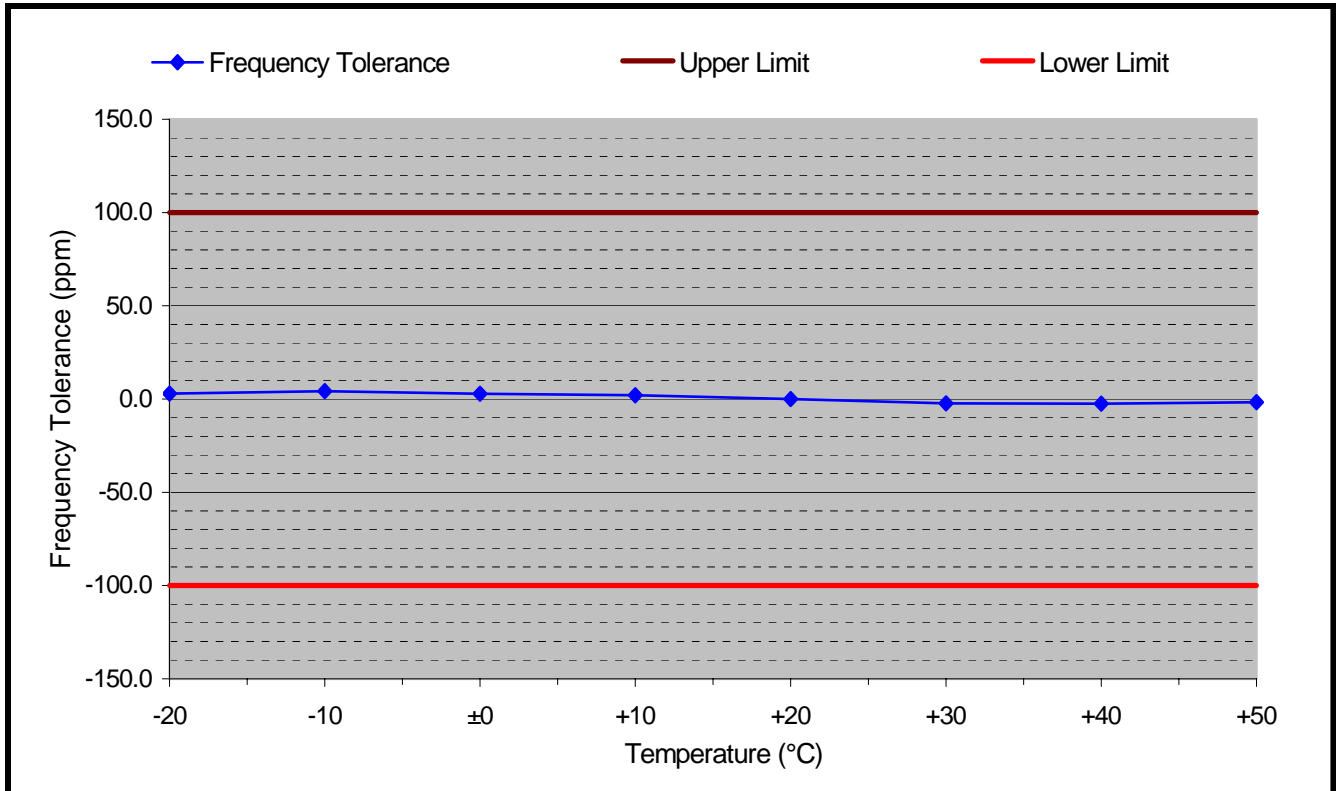

Supply voltage: 24 V      Nominal frequency: 13.559767 MHz

Temperature (°C)	Frequency (MHz)	Frequency Tolerance (Hz)	Frequency Tolerance (ppm)	Upper Limit (ppm)	Lower Limit (ppm)	Margin (ppm)
-20	13.559807	40	3.0	+100.0	-100.0	97.0
-10	13.559824	57	4.2	+100.0	-100.0	95.8
±0	13.559805	38	2.8	+100.0	-100.0	97.2
+10	13.559795	28	2.1	+100.0	-100.0	97.9
+20	13.559767	0	0.0	+100.0	-100.0	100.0
+30	13.559735	-31	-2.3	+100.0	-100.0	97.7
+40	13.559733	-34	-2.5	+100.0	-100.0	97.5
+50	13.559744	-23	-1.7	+100.0	-100.0	98.3

Test Result: Test passed





### 7.8.3 Carrier Frequency Stability vs. Supply Voltage

#### ISO mode

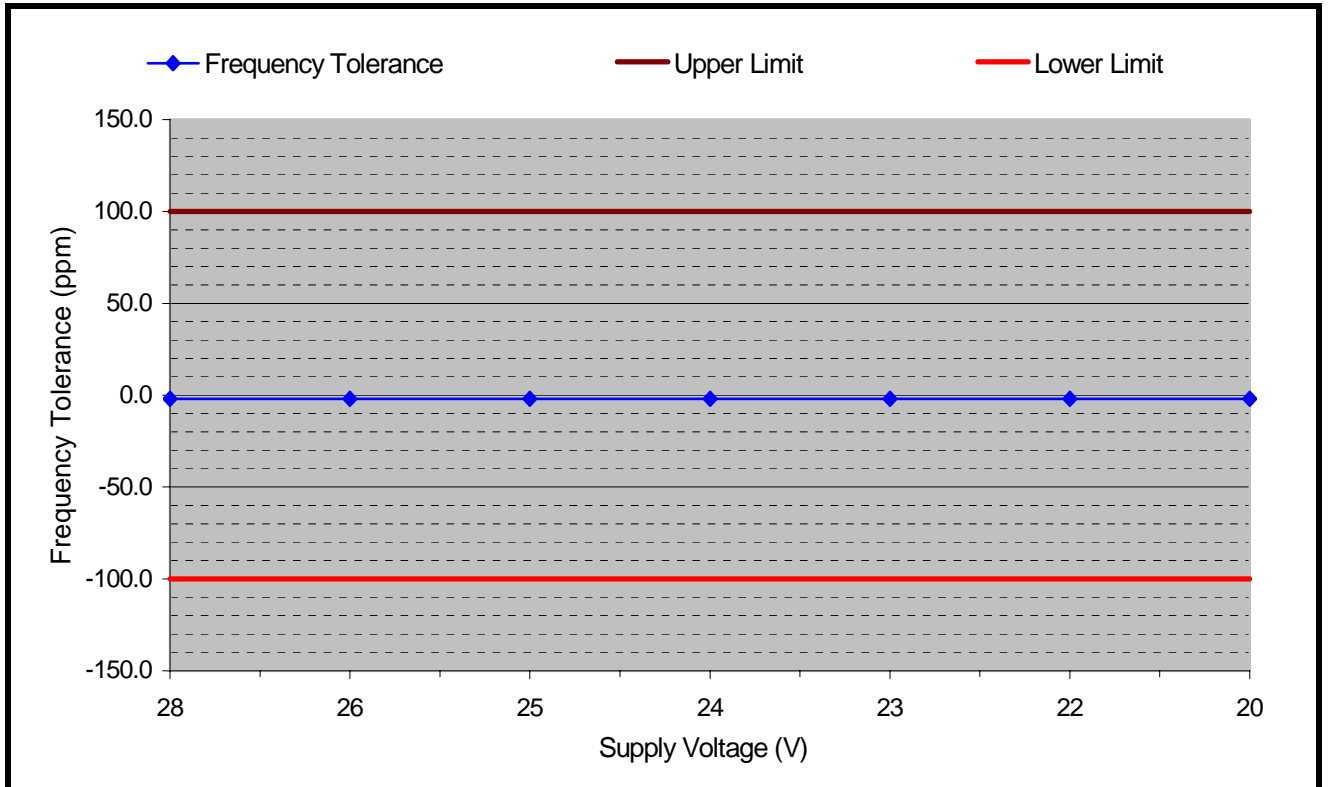

Temperature: +20 °C      Battery End Point: Not applicable  
 Nominal frequency: 13.559800 MHz

Supply Voltage (V)	Frequency (MHz)	Frequency Tolerance (Hz)	Frequency Tolerance (ppm)	Upper Limit (ppm)	Lower Limit (ppm)	Margin (ppm)
28	13.559774	-26	-1.9	+100.0	-100.0	<b>98.1</b>
26	13.559774	-26	-1.9	+100.0	-100.0	<b>98.1</b>
25	13.559774	-26	-1.9	+100.0	-100.0	<b>98.1</b>
24	13.559774	-26	-1.9	+100.0	-100.0	<b>98.1</b>
23	13.559774	-26	-1.9	+100.0	-100.0	<b>98.1</b>
22	13.559774	-26	-1.9	+100.0	-100.0	<b>98.1</b>
20	13.559774	-26	-1.9	+100.0	-100.0	<b>98.1</b>

Test Result:	Test passed
--------------	-------------

### 7.8.4 Carrier Frequency Stability vs. Supply Voltage

#### RF 300 mode

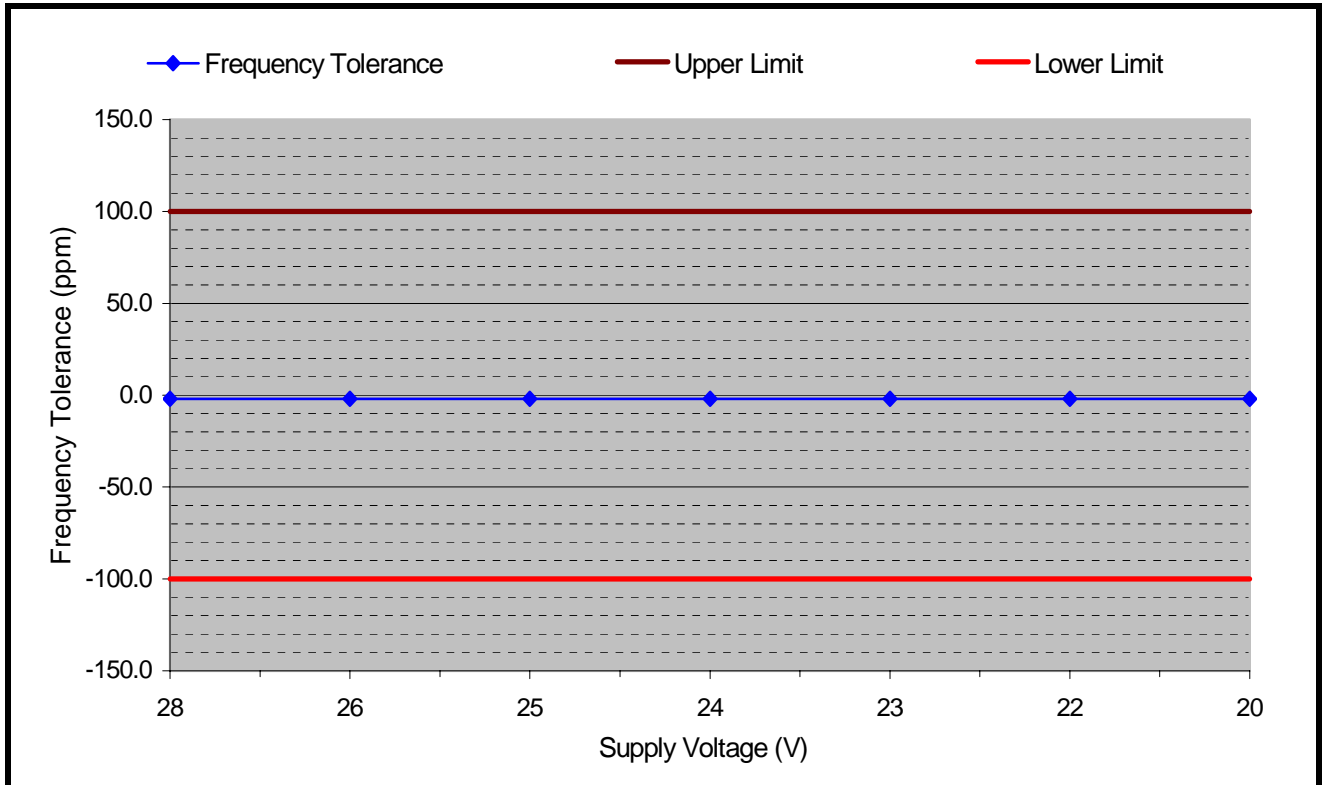

Temperature: +20 °C      Battery End Point: Not applicable  
 Nominal frequency: 13.559800 MHz

Supply Voltage (V)	Frequency (MHz)	Frequency Tolerance (Hz)	Frequency Tolerance (ppm)	Upper Limit (ppm)	Lower Limit (ppm)	Margin (ppm)
28	13.559774	-26	-1.9	+100.0	-100.0	<b>98.1</b>
26	13.559774	-26	-1.9	+100.0	-100.0	<b>98.1</b>
25	13.559774	-26	-1.9	+100.0	-100.0	<b>98.1</b>
24	13.559774	-26	-1.9	+100.0	-100.0	<b>98.1</b>
23	13.559774	-26	-1.9	+100.0	-100.0	<b>98.1</b>
22	13.559774	-26	-1.9	+100.0	-100.0	<b>98.1</b>
20	13.559774	-26	-1.9	+100.0	-100.0	<b>98.1</b>

Test Result:	Test passed
--------------	-------------

## 7.9 Exposure of Humans to RF Fields

Rules and specifications:	IC RSS-Gen Issue 2, section 5.5
Guide:	IC RSS-102 Issue 2, section 2.5

Exposure of Humans to RF Fields	Applicable	Declared by applicant	Measured	Exemption
<b>The antenna is</b>				
<input checked="" type="checkbox"/> detachable				
<p>The conducted output power (CP in watts) is measured at the antenna connector:</p> $CP = \dots\dots\dots \mathbf{W}$ <p>The effective isotropic radiated power (EIRP in watts) is calculated using</p> <p><input type="checkbox"/> the numerical antenna gain: <math>G = \dots\dots\dots</math></p> $EIRP = G \cdot CP \Rightarrow EIRP = \dots\dots\dots \mathbf{W}$ <p><input checked="" type="checkbox"/> the field strength<sup>8</sup> in V/m: <math>FS = \mathbf{0.00063V/m}</math></p> $EIRP = \frac{(FS \cdot D)^2}{30} \Rightarrow EIRP = \mathbf{1.323^{-6} W}$ <p>with:</p> <p>Distance between the antennas in m: <math>D = \mathbf{.10m}</math></p>			<input type="checkbox"/>	<input checked="" type="checkbox"/>
<input type="checkbox"/> not detachable				
<p>A field strength measurement is used to determine the effective isotropic radiated power (EIRP in watts) given by<sup>8</sup>:</p> $EIRP = \frac{(FS \cdot D)^2}{30} \Rightarrow EIRP = \dots\dots\dots \mathbf{W}$ <p>with:</p> <p>Field strength in V/m: <math>FS = \dots\dots\dots \mathbf{V/m}</math></p> <p>Distance between the two antennas in m: <math>D = \dots\dots\dots \mathbf{m}</math></p>			<input type="checkbox"/>	<input type="checkbox"/>
<b>Selection of output power</b>				
<p>The output power TP is the higher of the conducted or effective isotropic radiated power (e.i.r.p.):</p> $TP = \mathbf{1.323^{-6} W}$				

<sup>8</sup> The conversion formula is valid only for properly matched antennas. In other cases the transmitter output power may have to be measured by a terminated measurement when applying the exemption clauses. If an open area test site is used for field strength measurement, the effect due to the metal ground reflecting plane should be subtracted from the maximum field strength value in order to reference it to free space, before calculating TP.



## 8 Referenced Regulations

All tests were performed with reference to the following regulations and standards:

<input checked="" type="checkbox"/>	CFR 47 Part 2	Code of Federal Regulations Part 2 (Frequency allocation and radio treaty matters; General rules and regulations) of the Federal Communication Commission (FCC)	October 1, 2008
<input checked="" type="checkbox"/>	CFR 47 Part 15	Code of Federal Regulations Part 15 (Radio Frequency Devices) of the Federal Communication Commission (FCC)	October 1, 2008
<input checked="" type="checkbox"/>	ANSI C63.4	American National Standard for Methods of Measurement of Radio-Noise Emissions from Low-Voltage Electrical and Electronic Equipment in the Range of 9 kHz to 40 GHz	December 11, 2003 (published on January 30, 2004)
<input checked="" type="checkbox"/>	RSS-Gen	Radio Standards Specification RSS-Gen Issue 2 containing General Requirements and Information for the Certification of Radiocommunication Equipment, published by Industry Canada	June 2007
<input checked="" type="checkbox"/>	RSS-210	Radio Standards Specification RSS-210 Issue 7 for Low Power Licence-Exempt Radiocommunication Devices (All Frequency Bands): Category I Equipment, published by Industry Canada	June 2007
<input type="checkbox"/>	RSS-310	Radio Standards Specification RSS-310 Issue 1 for Low Power Licence-Exempt Radiocommunication Devices (All Frequency Bands): Category II Equipment, published by Industry Canada	September 2005
<input checked="" type="checkbox"/>	RSS-102	Radio Standards Specification RSS-102 Issue 2: Radio Frequency Exposure Compliance of Radiocommunication Apparatus (All Frequency Bands)	November 2005
<input type="checkbox"/>	ICES-003	Interference-Causing Equipment Standard ICES-003 Issue 4 for Digital Apparatus, published by Industry Canada	February 7, 2004
<input checked="" type="checkbox"/>	CISPR 22	Third Edition of the International Special Committee on Radio Interference (CISPR), Pub. 22, "Information Technology Equipment – Radio Disturbance Characteristics – Limits and Methods of Measurement"	1997
<input type="checkbox"/>	CAN/CSA-CEI/IEC CISPR 22	Limits and Methods of Measurement of Radio Disturbance Characteristics of Information Technology Equipment	2002

TRC-43

Notes Regarding Designation of Emission (Including  
Necessary Bandwidth and Classification), Class of  
Station and Nature of Service, published by Industry  
Canada

October 9, 1982

## 9 Revision History

Revision History			
<i>Edition</i>	<i>Date</i>	<i>Issued by</i>	<i>Modifications</i>
1	19.10.09	J. Roidt	First Edition

TÜV SÜD SENTON GmbH  
Äußere Frühlingstraße 45  
94315 Straubing  
Germany

Phone: +49 9421 5522-0  
Fax: +49 9421 5522-99  
Web: [www.tuev-sued.com/senton](http://www.tuev-sued.com/senton)



SENTON

---