



Product Service

Choose certainty.
Add value.

September 13,
2013

Page 1 of 68

Prüfbericht / Test Report

Nr. / No. 14912-24986-4 (Edition 1)

Applicant: Siemens AG, Fürth
Type of equipment: RFID Reader
Type designation: RF250R
Order No.: 2072052749
Test standards: FCC Code of Federal Regulations,
CFR 47, Part 15,
Sections 15.205, 15.207, 15.215 and 15.225

Industry Canada Radio Standards Specifications
RSS-GEN Issue 3, Sections 7.2.2, 7.2.4 and 7.2.5 and
RSS-210 Issue 8, Section A2.6 (Category I Equipment)

Note:

The test data of this report is related only to the individual item which has been tested. This report shall not be reproduced except in full extent without the written approval of the testing laboratory.



Table of Contents

1	Description of the Equipment Under Test (EUT)	3
2	Administrative Data	4
3	Identification of the Test Laboratory	5
4	Summary	6
5	Operation Mode and Configuration of EUT	7
6	Measurement Procedures	8
6.1	Conducted Output Power	8
6.2	Bandwidth Measurements	10
6.3	Conducted AC Powerline Emission	12
6.4	Radiated Emission Measurement 9 kHz to 30 MHz	14
6.5	Radiated Emission in Fully or Semi Anechoic Room	16
6.6	Radiated Emission at Alternative Test Site	18
6.7	Carrier Frequency Stability	20
7	Photographs Taken During Testing	22
8	Test Results	30
8.1	Conducted Output Power	32
8.2	Occupied Bandwidth (ANT8)	33
8.3	Occupied Bandwidth (ANT30)	36
8.4	Bandwidth of the Emission (ANT8)	39
8.5	Bandwidth of the Emission (ANT30)	41
8.6	Designation of Emissions	43
8.7	Conducted Powerline Emission Measurement 150 kHz to 30 MHz	44
8.8	Spectrum Mask (ANT8)	45
8.9	Spectrum Mask (ANT30)	47
8.10	Radiated Emission Measurement 9 kHz to 30 MHz (ANT8)	49
8.11	Radiated Emission Measurement 9 kHz to 30 MHz (ANT30)	50
8.12	Radiated Emission Measurement 30 MHz to 1 GHz (ANT8)	52
8.13	Radiated Emission Measurement 30 MHz to 1 GHz (ANT30)	53
8.14	Carrier Frequency Stability	54
8.15	Exposure of Humans to RF Fields	57
9	Referenced Regulations	59
10	Test Equipment List with Calibration Data	61
11	Revision History	62
Annex A	Charts taken during testing	63

1 Description of the Equipment Under Test (EUT)

General data of EUT	
Type designation ¹ :	RF250R
Parts ² :	1
Serial number(s):	---
Manufacturer:	Siemens AG, Fürth
Type of equipment:	RFID Reader
Version:	
FCC ID:	NXW-RF250R
Industry Canada ID:	267X-RF250R
Additional parts/accessories:	

Technical data of EUT	
Application frequency range:	13.110 - 14.010 MHz
Frequency range:	N/A
Operating frequency:	13.560 MHz
Type of modulation:	ASK
Number of RF-channels:	1
Channel spacing:	N/A
Designation of emissions ³ :	2k8A1D
Type of antenna:	Inductive Loop
Size/length of antenna:	8mm (ANT8) to 30 mm (ANT30) diameter
Connection of antenna:	<input checked="" type="checkbox"/> detachable <input type="checkbox"/> not detachable
Type of power supply:	DC supply
Specifications for power supply:	nominal voltage: 24.0 V minimum voltage: 21.6 V maximum voltage: 26.4 V

¹ Type designation of the system if EUT consists of more than one part.

² Type designations of the parts of the system, if applicable.

³ Also known as "Class of Emission".



2 Administrative Data

Application details

Applicant (full address):	Siemens AG, Fürth Siemensstrasse 2-4, 90766 Fürth, Germany
Contact person:	Mr. Norbert Wluka
Order number:	2072052749
Receipt of EUT:	2013-07-15
Date(s) of test:	2013-07-15 – 2013-08-06
Note(s):	

Report details

Report number:	14912-24986-4
Edition:	1
Issue date:	2013-09-13



3 Identification of the Test Laboratory

Details of the Test Laboratory

Company name:	TÜV SÜD Product Service GmbH
Address:	Aeussere Fruehlingstrasse 45 D-94315 Straubing Germany
Laboratory accreditation:	DAkKS Registration No. D-PL-11321-11-01
FCC test site registration number	90926
Industry Canada test site registration:	3050A-2
Contact person:	Mr. Johann Roidt
	Phone: +49 9421 5522-0 Fax: +49 9421 5522-99

4 Summary

Summary of test results

The tested sample complies with the requirements set forth in the

Code of Federal Regulations CFR 47, Part 15, Sections 15.205, 15.207, 15.215 and 15.225

of the Federal Communication Commission (FCC) and the

Radio Standards Specifications

**RSS-GEN Issue 3, Sections 7.2.2, 7.2.4 and 7.2.5 and
RSS-210 Issue 8, Section , A2.6 (Category I Equipment)**

of Industry Canada (IC).

Personnel involved in this report

Laboratory Manager:



Mr. Johann Roidt

Responsible for testing:



Mr. Thomas Eberl

Responsible for test report:

Mr. Thomas Eberl



5 Operation Mode and Configuration of EUT

Operation Mode(s)

Continuously reading a transponder

Configuration(s) of EUT

EUT operated with external host device via RS 422 interface and DC powered from the similar cable trunk

List of ports and cables

<i>Port</i>	<i>Description</i>	<i>Classification⁴</i>	<i>Cable type</i>	<i>Cable length</i>
1	DC supply line	dc power	Unshielded	2.0 m
2	Antenna port (unique style)	signal/control port	Shielded (coax)	1.5 m

List of devices connected to EUT

<i>Item</i>	<i>Description</i>	<i>Type Designation</i>	<i>Serial no. or ID</i>	<i>Manufacturer</i>
1	Antenna	ANT8	---	Siemens AG
2	Antenna	ANT30	---	Siemens AG

List of support devices

<i>Item</i>	<i>Description</i>	<i>Type Designation</i>	<i>Serial no. or ID</i>	<i>Manufacturer</i>
1	None			

⁴ Ports shall be classified as ac power, dc power or signal/control port

6 Measurement Procedures

6.1 Conducted Output Power

Measurement Procedure:

Rules and specifications: CFR 47 Part 2, section 2.1046(a)
 IC RSS-Gen Issue 3, section 4.8

Guide: CFR 47 Part 2, section 2.1046 / IC RSS-Gen Issue 3

Conducted output power is measured at the RF output terminals (e.g. antenna connector if antenna is detachable) when the transmitter is adjusted in accordance with the tune-up procedure, if applicable. The RF output terminals are connected to a spectrum analyzer and/or a power meter with appropriate sensor. If required, a resistive matching network equal to the impedance specified or employed for the antenna is used as well as dc block and appropriate attenuators (50 Ohms). The electrical characteristics of the radio frequency load attached to the output terminals shall be stated, if applicable.

If a spectrum analyzer is used and no other settings are specified resolution bandwidth shall be selected according to the carrier frequency f_c and set to 10 kHz ($150 \text{ kHz} \leq f_c < 30 \text{ MHz}$), 100 kHz ($30 \text{ MHz} \leq f_c < 1 \text{ GHz}$) or 1 MHz ($f_c \geq 1 \text{ GHz}$). The video bandwidth shall be at least three times greater than the resolution bandwidth. The settings used have to be indicated within the appropriate test record(s).

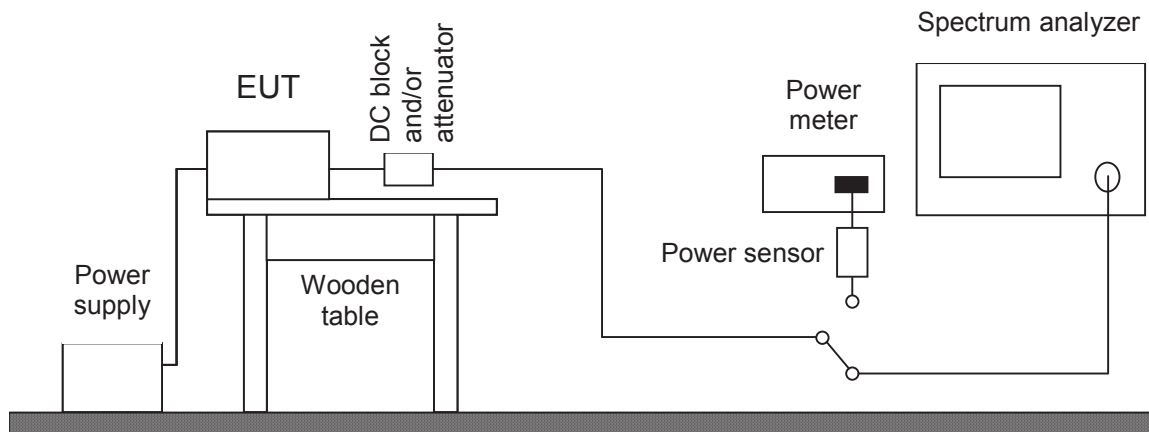



Test instruments used:

Type	Designation	Inv.-no.	Serial No. or ID	Manufacturer
<input type="checkbox"/> Spectrum analyzer	FSP30	1666	100063	Rohde & Schwarz
<input checked="" type="checkbox"/> EMI test receiver	ESPI7	1711	836914/0002	Rohde & Schwarz
<input type="checkbox"/> EMI test receiver	ESMI	1569	839379/013 839587/006	Rohde & Schwarz
<input type="checkbox"/> Power meter	NRVS	1264	836856/015	Rohde & Schwarz
<input type="checkbox"/> Peak power sensor	NRV-Z31	1701	8579604.03	Rohde & Schwarz
<input type="checkbox"/> Power sensor	NRV-Z52	1499	837901/030	Rohde & Schwarz
<input type="checkbox"/> Power sensor	NRV-Z4	1034	863828/015	Rohde & Schwarz
<input type="checkbox"/> DC-block	7006	1636	A2798	Weinschel
<input type="checkbox"/> Attenuator	4776-10	1638	9412	Narda
<input type="checkbox"/> Attenuator	4776-20	1639	9503	Narda

6.2 Bandwidth Measurements

Measurement Procedure:	
Rules and specifications:	CFR 47 Part 2, section 2.202(a) CFR 47 Part 15, section 15.215(c) IC RSS-Gen Issue 3, sections 4.6.1 and 4.6.2 IC RSS-210 Issue 8, section A1.1.3 ANSI C63.4, annex H.6
Guide:	ANSI C63.4 / IC RSS-Gen Issue 3, sections 4.6.1 and 4.6.2
Measurement setup:	<input checked="" type="checkbox"/> Conducted: See below <input checked="" type="checkbox"/> Radiated: Radiated Emission Measurement 9 kHz to 30 MHz (6.4)
<p>If antenna is detachable bandwidth measurements shall be performed at the antenna connector (conducted measurement) when the transmitter is adjusted in accordance with the tune-up procedure, if applicable. The RF output terminals are connected to a spectrum analyzer. If required, a resistive matching network equal to the impedance specified or employed for the antenna is used as well as dc block and appropriate attenuators (50 Ohms). The electrical characteristics of the radio frequency load attached to the output terminals shall be stated, if applicable.</p> <p>If radiated measurements are performed the same test setups and instruments are used as with radiated emission measurements for the appropriate frequency range.</p> <p>The analyzer settings are specified by the test description of the appropriate test record(s).</p>	

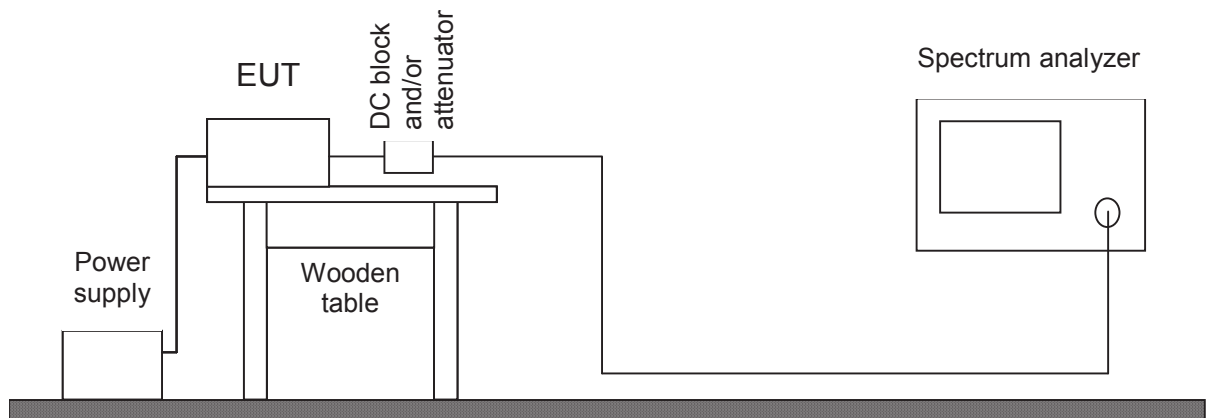



Test instruments used for conducted measurements:

Type	Designation	Inv.-no.	Serial No. or ID	Manufacturer
<input type="checkbox"/> Spectrum analyzer	FSP30	1666	100036	Rohde & Schwarz
<input checked="" type="checkbox"/> EMI test receiver	ESPI7	1711	836914/0002	Rohde & Schwarz
<input type="checkbox"/> EMI test receiver	ESMI	1569	839379/013 839587/006	Rohde & Schwarz
<input type="checkbox"/> Power meter	NRVS	1264	836856/015	Rohde & Schwarz
<input type="checkbox"/> Peak power sensor	NRV-Z31	1701	8579604.03	Rohde & Schwarz
<input type="checkbox"/> Power sensor	NRV-Z52	1499	837901/030	Rohde & Schwarz
<input type="checkbox"/> Power sensor	NRV-Z4	1034	863828/015	Rohde & Schwarz
<input type="checkbox"/> DC-block	7006	1636	A2798	Weinschel
<input type="checkbox"/> Attenuator	4776-10	1638	9412	Narda
<input type="checkbox"/> Attenuator	4776-20	1639	9503	Narda

6.3 Conducted AC Powerline Emission

Measurement Procedure:

Rules and specifications: CFR 47 Part 15, section 15.207
 IC RSS-Gen Issue 3, section 7.2.4

Guide: ANSI C63.4 / CISPR 22

Conducted emission tests in the frequency range 150 kHz to 30 MHz are performed using Line Impedance Stabilization Networks (LISNs). To simplify testing with quasi-peak and average detector the following procedure is used:

First the whole spectrum of emission caused by the equipment under test (EUT) is recorded with detector set to peak using CISPR bandwidth of 10 kHz. After that all emission levels having less margin than 10 dB to or exceeding the average limit are retested with detector set to quasi-peak.

If average limit is kept with quasi-peak levels no additional scan with average detector is necessary. In cases of emission levels between quasi-peak and average limit an additional scan with detector set to average is performed.

According to ANSI C63.4, section 13.1.3.1, testing of intentional radiators with detachable antenna shall be performed using a suitable dummy load connected to the antenna output terminals. Otherwise, the tests shall be made with the antenna connected and, if adjustable, fully extended.

Testing with dummy load may be necessary to distinguish (unintentional) conducted emissions on the supply lines from (intentional) emissions radiated by the antenna and coupling directly to supply lines and/or LISN. Usage of dummy load has to be stated in the appropriate test record(s) and notes should be added to clarify the test setup.

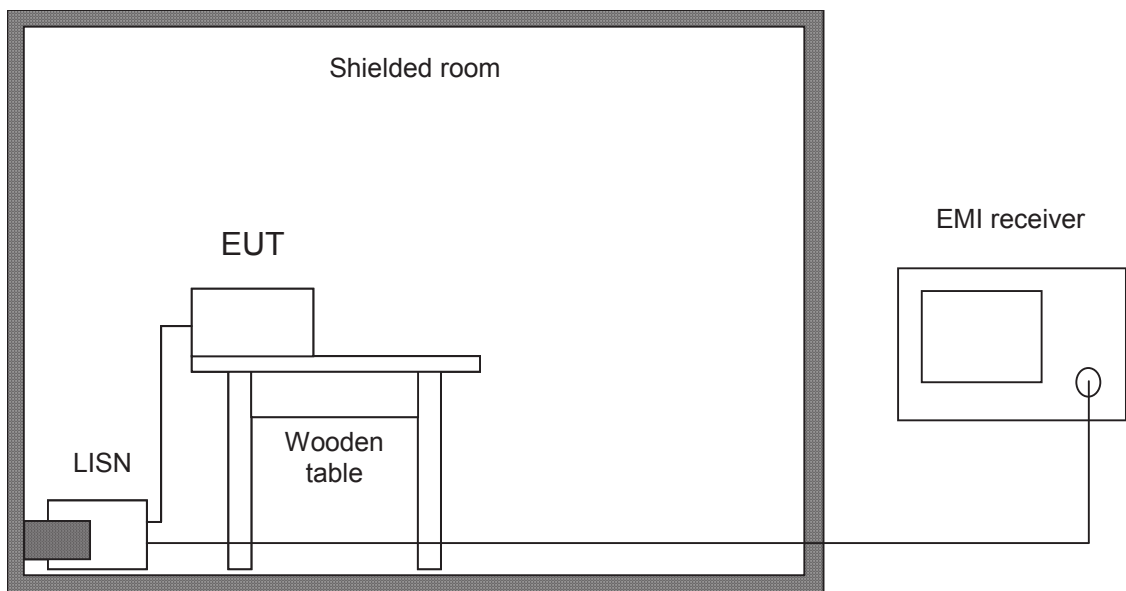



Test instruments used:

Type	Designation	Inv.-no.	Serial No. or ID	Manufacturer
<input checked="" type="checkbox"/> Test receiver	ESHS 10	1028	860043/016	Rohde & Schwarz
<input checked="" type="checkbox"/> V-network	ESH 3-Z5	1059	894785/005	Rohde & Schwarz
<input type="checkbox"/> V-network	ESH 3-Z5	1218	830952/025	Rohde & Schwarz
<input type="checkbox"/> Artificial mains network	ESH 2-Z5	1536	842966/004	Rohde & Schwarz
<input type="checkbox"/> Shielded room	No. 1	1451	---	Albatross
<input checked="" type="checkbox"/> Shielded room	No. 4	1454	3FD 100 544	Euroshield

6.4 Radiated Emission Measurement 9 kHz to 30 MHz

Measurement Procedure:

Rules and specifications: CFR 47 Part 15, sections 15.205, 15.215(b) and 15.225(a)-(d)
 IC RSS-GEN Issue 3, sections 7.2.2 and 7.2.5 and
 IC RSS-210 Issue 8, section A2.6

Guide: ANSI C63.4

Radiated emission in the frequency range 9 kHz to 30 MHz is measured using an active loop antenna. First the whole spectrum of emission caused by the equipment is recorded at a distance of 3 meters in a fully or semi anechoic room with the detector of the spectrum analyzer or EMI receiver set to peak. This configuration is also used for recording the spectrum of intentional radiators.

Hand-held or body-worn devices are rotated through three orthogonal axes to determine which attitude and configuration produces the highest emission relative to the limit and therefore shall be used for final testing.

EUT is rotated all around to find the maximum levels of emissions. Equipment and cables are placed and moved within the range of position likely to find their maximum emissions.

If worst case emission of the EUT cannot be recorded with EUT in standard position and loop antenna in vertical polarization the EUT (or the radiating part of the EUT) is rotated by 90 degrees instead of changing the loop antenna to horizontal polarization. This procedure is selected to minimize the influence of the environment (e.g. effects caused by the floor especially with longer distances).

Final measurement is performed at a test distance D of 30 meters using an open field test site. In case the regulation requires testing at other distances, the result is extrapolated by either making measurements at an additional distance D of 10 meters to determine the proper extrapolation factor or by using the square of an inverse linear distance extrapolation factor (40 dB/decade). In cases of very low emissions measurements are performed at shorter distances and results are extrapolated to the required distance. The provisions of CFR 47 Part 15 sections 15.31(d) and (f)(2) apply. According to CFR 47 Part 15 section 15.209(d) final measurement is performed with detector function set to quasi-peak except for the frequency bands 9 to 90 kHz and 110 to 490 kHz where, for non-pulsed operation, average detector is employed.

If the radiated emission limits are expressed in terms of the average value of the emission there also is a peak limit corresponding to 20 dB above the maximum permitted average limit. Additionally, if pulsed operation is employed, the average field strength is determined by averaging over one complete pulse train, including blanking intervals, as specified in CFR 47 Part 15 section 15.35(c). If the pulse train exceeds 0.1 second that 0.1 second interval during which the value of the emission is at its maximum is selected for calculation. The pulse train correction is added to the peak value of the emission to get the average value.

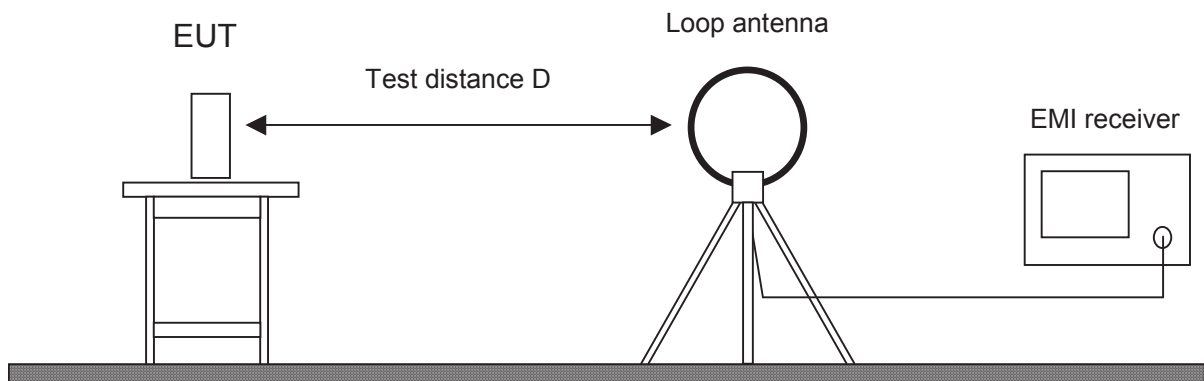



Test instruments used:

Type	Designation	Inv.-no.	Serial No. or ID	Manufacturer
<input type="checkbox"/> Spectrum analyzer	FSP30	1666	100036	Rohde & Schwarz
<input type="checkbox"/> EMI test receiver	ESMI	1569	839379/013 839587/006	Rohde & Schwarz
<input checked="" type="checkbox"/> Test receiver	ESHS 10	1028	860043/016	Rohde & Schwarz
<input type="checkbox"/> Preamplifier	Cabin no. 2 CPA9231A	1716	3557	Schaffner
<input checked="" type="checkbox"/> Loop antenna	HFH2-Z2	1016	882964/1	Rohde & Schwarz
<input type="checkbox"/> Fully anechoic room	No. 2	1452	---	Albatross
<input type="checkbox"/> Semi anechoic room	No. 3	1453	---	Siemens
<input checked="" type="checkbox"/> Semi anechoic room	No. 8	2057	---	Albatross

6.5 Radiated Emission in Fully or Semi Anechoic Room

Measurement Procedure:	
Rules and specifications:	CFR 47 Part 15, sections 15.205(b) and 15.225(d) IC RSS-GEN Issue 3, sections 7.2.2(b)(c) and 7.2.5 and IC RSS-210 Issue 8, section A2.6
Guide:	ANSI C63.4
<p>Radiated emission in fully or semi anechoic room is measured in the frequency range from 30 MHz to the maximum frequency as specified in CFR 47 Part 15 section 15.33.</p> <p>Measurements are made in both the horizontal and vertical planes of polarization using a spectrum analyzer with the detector function set to peak and resolution as well as video bandwidth set to 100 kHz (below 1 GHz) or 1 MHz (above 1 GHz).</p> <p>Testing up to 1 GHz is performed with a linear polarized logarithmic periodic antenna combined with a 4:1 broadband dipole ("Trilog broadband antenna"). For testing above 1 GHz horn antennas are used.</p> <p>All tests below 8.2 GHz are performed at a test distance D of 3 meters. For higher frequencies the test distance may be reduced (e.g. to 1 meter) due to the sensitivity of the measuring instrument(s) and the test results are calculated according to CFR 47 Part 15 section 15.31(f)(1) using an extrapolation factor of 20 dB/decade. If required, preamplifiers are used for the whole frequency range. Special care is taken to avoid overload, using appropriate attenuators and filters, if necessary.</p> <p>If the radiated emission limits are expressed in terms of the average value of the emission there also is a peak limit corresponding to 20 dB above the maximum permitted average limit. Additionally, if pulsed operation is employed, the average field strength is determined by averaging over one complete pulse train, including blanking intervals, as specified in CFR 47 Part 15 section 15.35(c). If the pulse train exceeds 0.1 second that 0.1 second interval during which the value of the emission is at its maximum is selected for calculation. The pulse train correction is added to the peak value of the emission to get the average value.</p> <p>Hand-held or body-worn devices are rotated through three orthogonal axes to determine which attitude and configuration produces the highest emission relative to the limit and therefore shall be used for final testing.</p> <p>During testing the EUT is rotated all around to find the maximum levels of emissions. Equipment and cables are placed and moved within the range of position likely to find their maximum emissions.</p> <p>For final testing below 1 GHz a semi anechoic room complying with the NSA requirements of ANSI C63.4 for alternative test sites is used (see 6.6). If prescans are recorded in fully anechoic room they are indicated appropriately.</p>	

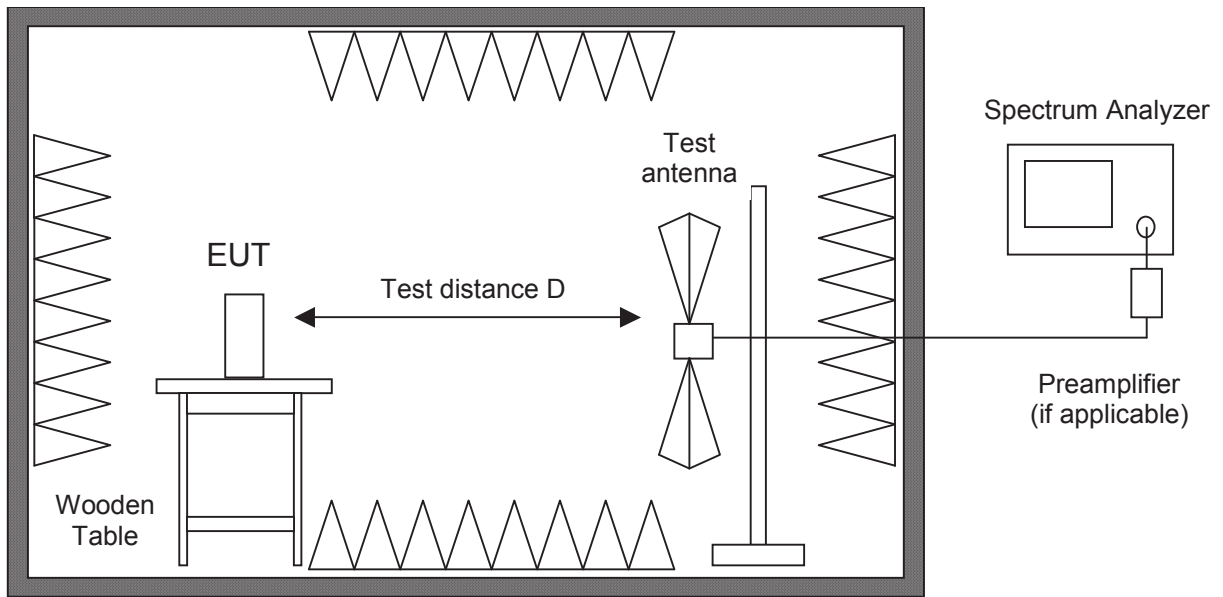

Fully or semi anechoic room

Test instruments used:

Type		Designation	Inv.-no.	Serial No. or ID	Manufacturer
<input checked="" type="checkbox"/>	Spectrum analyzer	FSP30	1666	100036	Rohde & Schwarz
<input type="checkbox"/>	EMI test receiver	Cabin no. 3 ESPI7	2010	101018	Rohde & Schwarz
<input type="checkbox"/>	EMI test receiver	ESU8	2044	100232	Rohde & Schwarz
<input type="checkbox"/>	EMI test receiver	ESMI	1569	839379/013 839587/006	Rohde & Schwarz
<input type="checkbox"/>	Preamplifier	Cabin no. 2 CPA9231A	1716	3557	Schaffner
<input type="checkbox"/>	Preamplifier	R14601	1142	13120026	Advantest
<input type="checkbox"/>	Preamplifier (1 - 8 GHz)	AFS3-00100800-32-LN	1684	847743	Miteq
<input type="checkbox"/>	Preamplifier (0.5 - 8 GHz)	AMF-4D-005080-25-13P	1685	860149	Miteq
<input type="checkbox"/>	Preamplifier (8 - 18 GHz)	ACO/180-3530	1484	32641	CTT
<input type="checkbox"/>	External Mixer	WM782A	1576	845881/005	Tektronix
<input type="checkbox"/>	Harmonic Mixer Accessories	FS-Z30	1577	624413/003	Rohde & Schwarz
<input checked="" type="checkbox"/>	Trilog antenna	Cabin no. 2 VULB 9163	1802	9163-214	Schwarzbeck
<input type="checkbox"/>	Trilog antenna	Cabin no. 3 VULB 9163	1722	9163-188	Schwarzbeck
<input type="checkbox"/>	Trilog antenna	Cabin no. 8 VULB 9163	2058	9163-408	Schwarzbeck
<input type="checkbox"/>	Horn antenna	3115	1516	9508-4553	EMCO
<input type="checkbox"/>	Horn antenna	3160-03	1010	9112-1003	EMCO
<input type="checkbox"/>	Horn antenna	3160-04	1011	9112-1001	EMCO
<input type="checkbox"/>	Horn antenna	3160-05	1012	9112-1001	EMCO
<input type="checkbox"/>	Horn antenna	3160-06	1013	9112-1001	EMCO
<input type="checkbox"/>	Horn antenna	3160-07	1014	9112-1008	EMCO
<input type="checkbox"/>	Horn antenna	3160-08	1015	9112-1002	EMCO
<input type="checkbox"/>	Horn antenna	3160-09	1265	9403-1025	EMCO
<input type="checkbox"/>	Horn antenna	3160-10	1575	399185	EMCO
<input type="checkbox"/>	Fully anechoic room	No. 2	1452	---	Albatross
<input type="checkbox"/>	Semi anechoic room	No. 3	1453	---	Siemens
<input type="checkbox"/>	Semi anechoic room	No. 8	2057	---	Albatross

6.6 Radiated Emission at Alternative Test Site

Measurement Procedure:	
Rules and specifications:	CFR 47 Part 15, sections 15.205(b) and 15.225(d) IC RSS-GEN Issue 3, sections 7.2.2(b)(c) and 7.2.5 and IC RSS-210 Issue 8, section A2.6
Guide:	ANSI C63.4
<p>Radiated emission in the frequency range 30 MHz to 1 GHz is measured within a semi-anechoic room with groundplane complying with the NSA requirements of ANSI C63.4 for alternative test sites. A linear polarized logarithmic periodic antenna combined with a 4:1 broadband dipole ("Trilog broadband antenna") is used. The measurement bandwidth of the test receiver is set to 120 kHz with quasi-peak detector selected.</p> <p>If the radiated emission limits are expressed in terms of the average value of the emission there also is a peak limit corresponding to 20 dB above the maximum permitted average limit. Additionally, if pulsed operation is employed, the average field strength is determined by averaging over one complete pulse train, including blanking intervals, as specified in CFR 47 Part 15 section 15.35(c). If the pulse train exceeds 0.1 second that 0.1 second interval during which the value of the emission is at its maximum is selected for calculation. The pulse train correction is added to the peak value of the emission to get the average value.</p> <p>Hand-held or body-worn devices are tested in the position producing the highest emission relative to the limit as verified by prescans in fully anechoic room.</p> <p>If no prescan in a fully anechoic room is used first a peak scan is performed in four positions to get the whole spectrum of emission caused by EUT with the measuring antenna raised and lowered from 1 to 4 m to find table position, antenna height and antenna polarization for the maximum emission levels.</p> <p>Data reduction is applied to these results to select those levels having less margin than 10 dB to or exceeding the limit using subranges and limited number of maximums. Further maximization is following.</p> <p>With detector of the test receiver set to quasi-peak final measurements are performed immediately after frequency zoom (for drifting disturbances) and maximum adjustment.</p> <p>Equipment and cables are placed and moved within the range of position likely to find their maximum emissions.</p> <p>In cases where prescans in a fully anechoic room are taken (e. g. if EUT is operating for a short time only or battery is discharged quickly) final measurements with quasi-peak detector are performed manually at frequencies indicated by prescan with EUT rotating all around and receiving antenna raising and lowering within 1 meter to 4 meters to find the maximum levels of emission.</p> <p>Equipment and cables are placed and moved within the range of position likely to find their maximum emissions.</p> <p>For measuring emissions of intentional radiators and receivers a test distance D of 3 meters is selected. Testing of unintentional radiators is performed at a distance of 10 meters. If limits specified for 3 meters shall be used for measurements performed at 10 meters distance the limits are calculated according to CFR 47 Part 15 section 15.31(d) and (f)(1) using an inverse linear-distance extrapolation factor of 20 dB/decade.</p>	

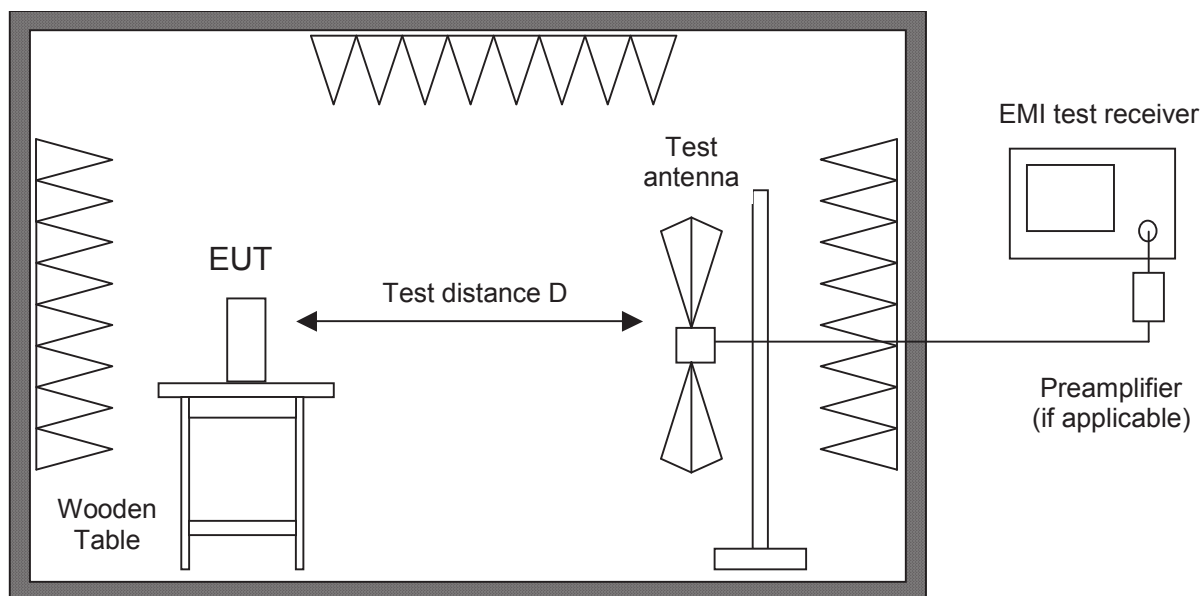

Alternate test site (semi anechoic room)

Test instruments used:

Type	Designation	Inv.-no.	Serial No. or ID	Manufacturer
<input checked="" type="checkbox"/> EMI test receiver	ESU8	2044	100232	Rohde & Schwarz
<input checked="" type="checkbox"/> Trilog antenna	Cabin no. 8 VULB 9163	2058	9163-408	Schwarzbeck
<input checked="" type="checkbox"/> Semi anechoic room	No. 8	2057	---	Albatross

6.7 Carrier Frequency Stability

Measurement Procedure:

Rules and specifications:	CFR 47 Part 15, section 15.225(e) IC RSS-Gen Issue 3, section 4.7 and IC RSS-210 Issue 8, section A2.6
Guide:	ANSI C63.4

The frequency tolerance of the carrier signal is measured over a temperature variation of -20 °C to +50 °C at normal supply voltage, and for a variation in the primary supply voltage from 85% to 115% of the rated supply voltage at a temperature of 20 °C.

If the EUT provides an antenna connector the spectrum analyzer is connected to this port. If required, a resistive matching network equal to the impedance specified or employed for the antenna is used as well as dc block and appropriate attenuators (50 Ohms). In cases where the EUT does not provide an antenna connector a test fixture is used.

For battery operated equipment, the test is performed using a new battery. Alternatively, an external supply voltage can be used and is at least set to:

- the maximum battery voltage as delivered by a new battery or 115% of the battery nominal voltage
- the battery nominal voltage
- 85% of the battery nominal voltage
- the battery operating end point voltage which shall be specified by the equipment manufacturer

The EUT is operating providing an unmodulated carrier. The peak detector of the spectrum analyzer is selected and resolution as well as video bandwidth are set to values appropriate to the shape of the spectrum of the EUT. The frequency counter mode of the spectrum analyzer is used to maximize the accuracy of the measured frequency tolerance.

If an unmodulated carrier is not available a significant and stable point on the spectrum is selected and the span is reduced to a value that delivers an accuracy which shall be better than 1% of the maximum frequency tolerance allowed for the carrier signal. This method may be performed as long as the margin to the frequency tolerance allowed is larger than the uncertainty of the measured frequency tolerance.

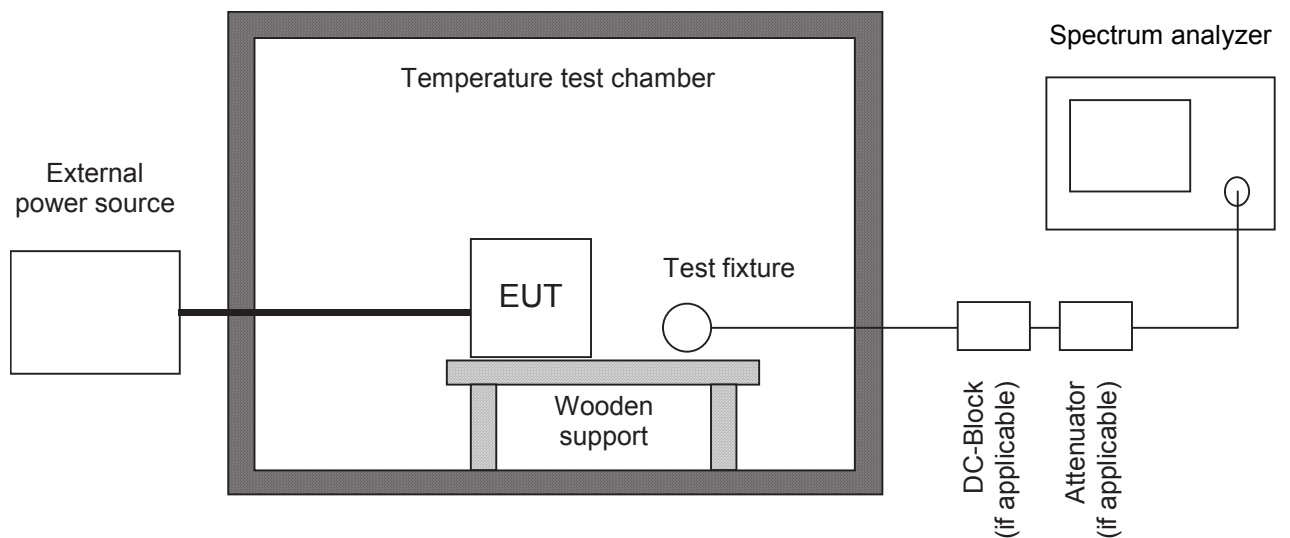

Test instruments used:

Type	Designation	Inv.-no.	Serial No. or ID	Manufacturer
<input type="checkbox"/> Spectrum analyzer	FSP30	1666	100036	Rohde & Schwarz
<input checked="" type="checkbox"/> EMI test receiver	ESPI7	1711	836914/0002	Rohde & Schwarz
<input type="checkbox"/> EMI test receiver	ESMI	1569	839379/013 839587/006	Rohde & Schwarz
<input type="checkbox"/> DC-block	7006	1636	A2798	Weinschel
<input type="checkbox"/> Attenuator	4776-10	1638	9412	Narda
<input type="checkbox"/> Attenuator	4776-20	1639	9503	Narda
<input checked="" type="checkbox"/> Test probe	TP 01	1628	001	TÜV SÜD PS
<input type="checkbox"/> Multimeter	21 III	1653	76530546	Fluke
<input type="checkbox"/> Multimeter	21 III	1654	76381229	Fluke
<input type="checkbox"/> Multimeter	Fluke 77 III	1975	92370108	Fluke
<input type="checkbox"/> Multimeter	Fluke 77 IV	1976	93090238	Fluke
<input type="checkbox"/> Multimeter	Fluke 177	2025	96720024	Fluke
<input type="checkbox"/> Multimeter	Fluke 177	2026	96720025	Fluke
<input checked="" type="checkbox"/> DC power supply	NGSM 32/10	1267	203	Rohde & Schwarz
<input type="checkbox"/> Isolating transformer	RT 5A	1127	10387	Grundig
<input type="checkbox"/> Isolating transformer	RT 5A	1128	10416	Grundig
<input checked="" type="checkbox"/> Temperature test chamber	HT 4010	1271	07065550	Heraeus



7 Photographs Taken During Testing

Test setup for conducted AC powerline emission measurement



Test setup for conducted AC powerline emission measurement - continued -



Test setup for radiated emission measurement 9 kHz – 30 MHz

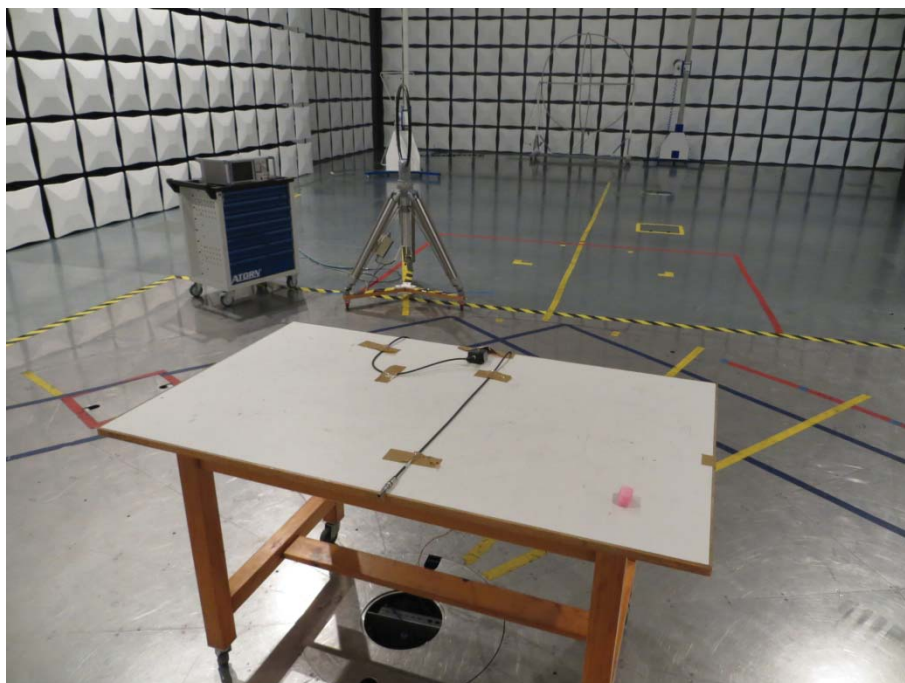
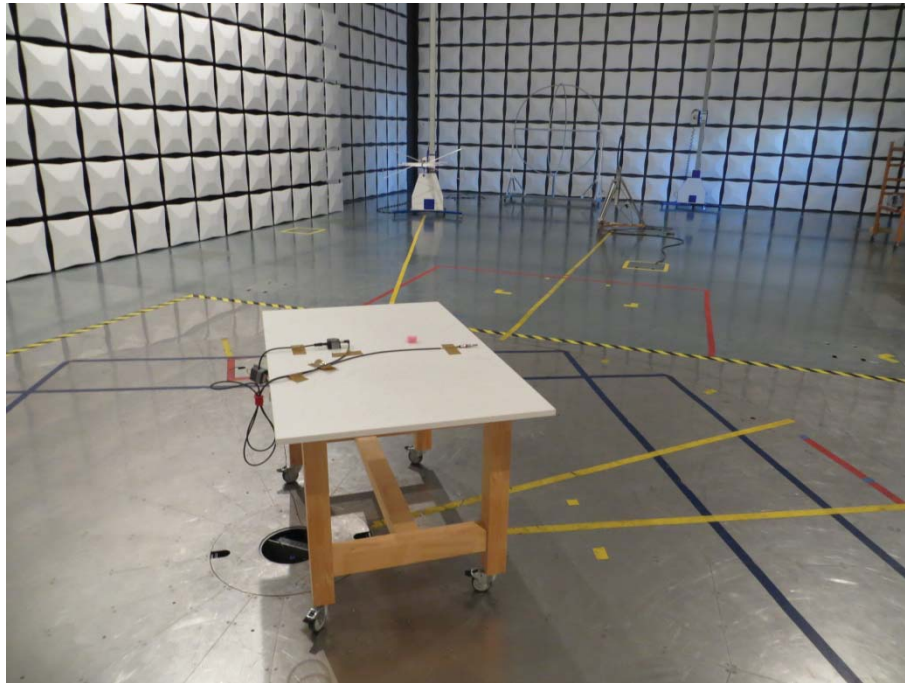

Test setup for radiated emission measurement (fully anechoic room)

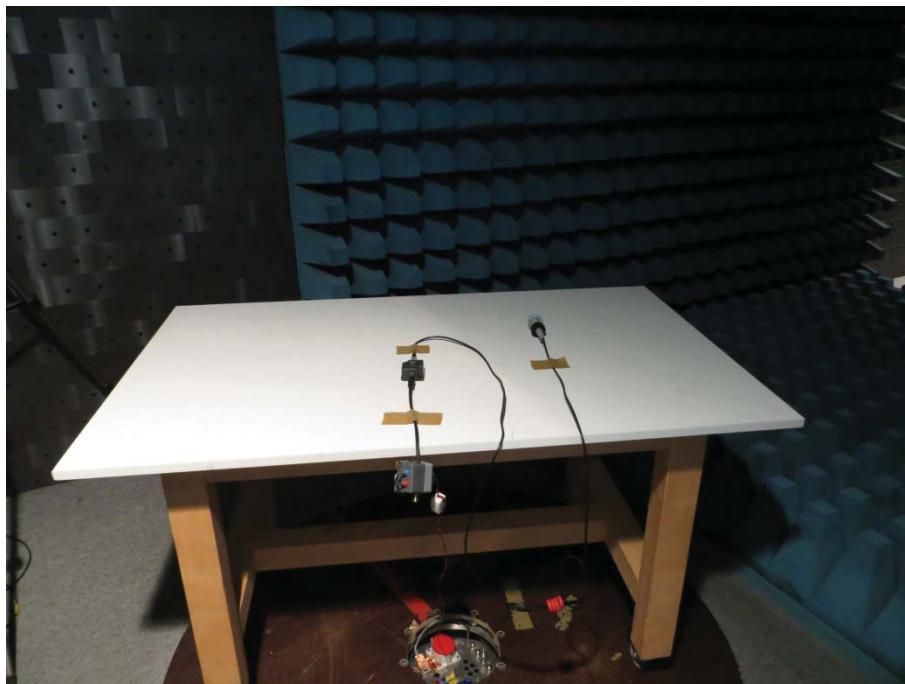

Test setup for radiated emission measurement (alternate test site)

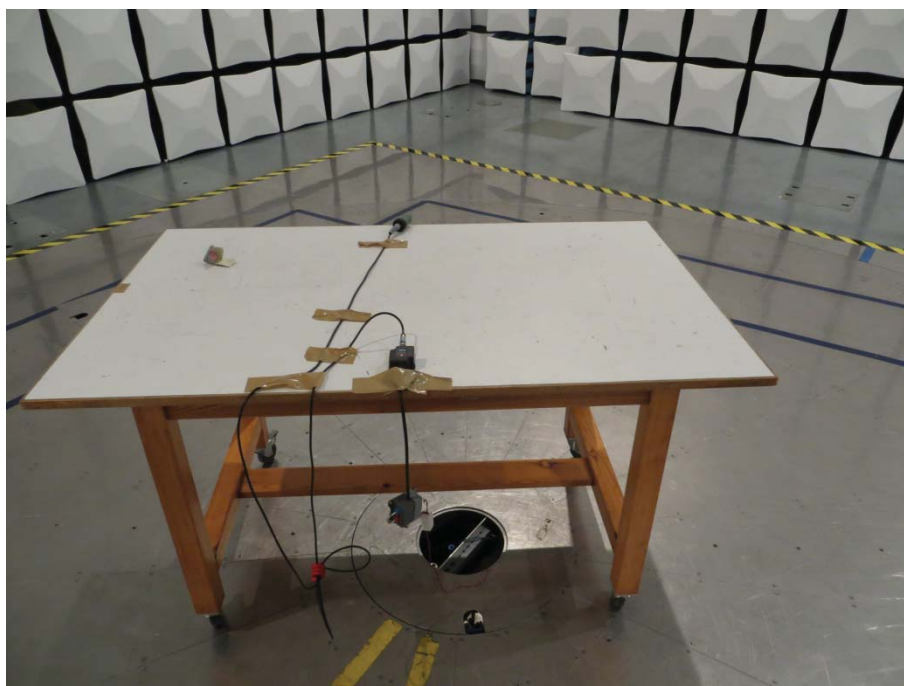

Test setup for radiated emission measurement (alternate test site) - continued -

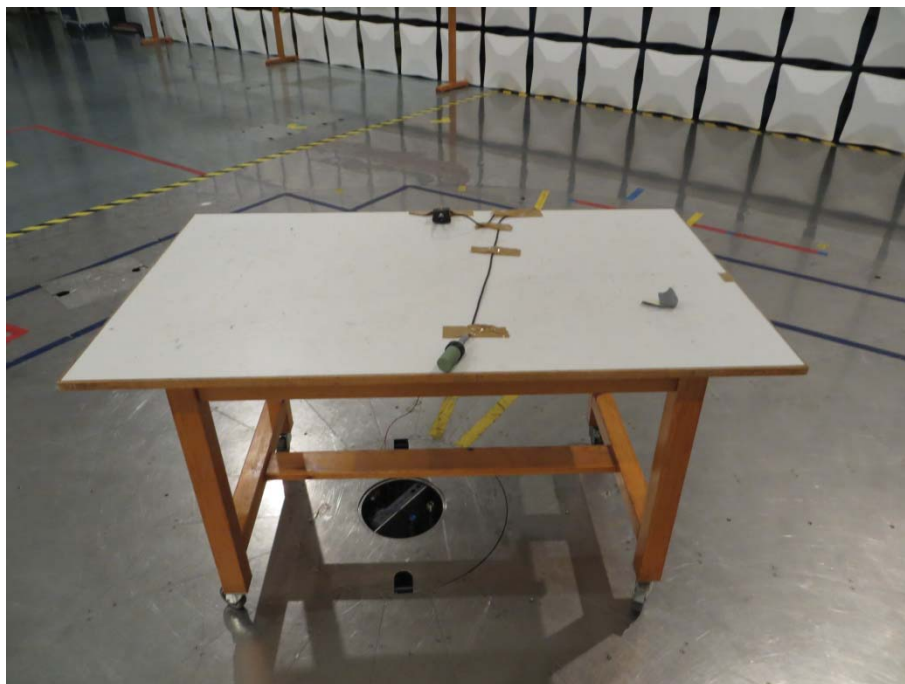

Test setup for carrier frequency stability measurement

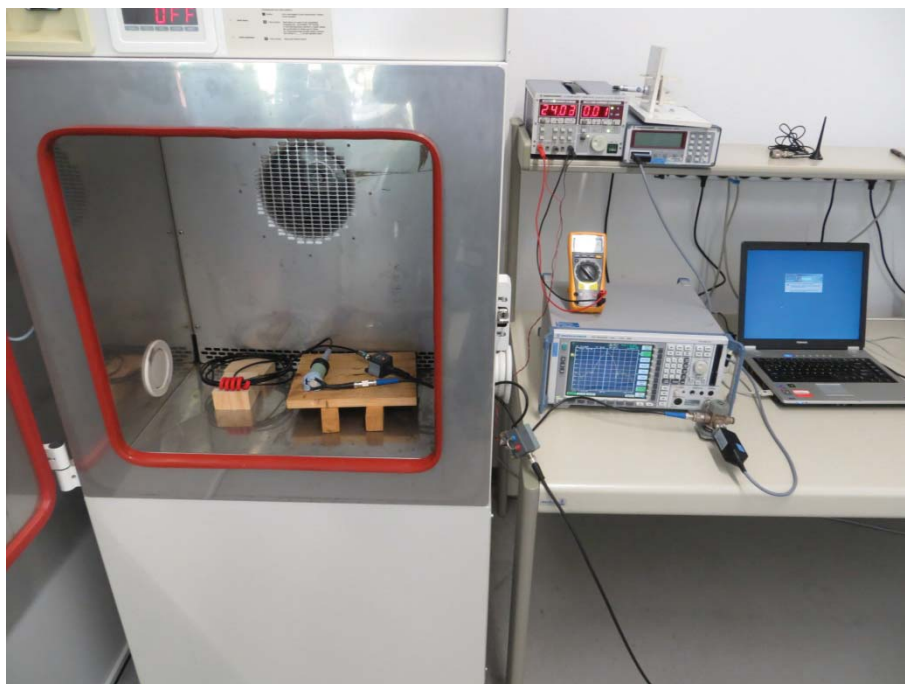



8 Test Results

FCC CFR 47 Parts 2 and 15			
Section(s)	Test	Page	Result
2.1046(a)	Conducted output power	32	Recorded
2.202(a)	Occupied bandwidth	33	Recorded
15.215(c)	Bandwidth of the emission	39	Test passed
2.201, 2.202	Class of emission	43	Calculated
15.35(c)	Pulse train measurement for pulsed operation	---	Not applicable
15.205(a) 15.205(d)(7)	Restricted bands of operation	--- ⁵	Test passed
15.207	Conducted AC powerline emission 150 kHz to 30 MHz	44	Test passed
15.225(a)-(d)	Spectrum Mask	45	Test passed
15.205(b) 15.215(b) 15.225(a)(d)	Radiated emission 9 kHz to 30 MHz	49	Test passed
15.205(b) 15.225(d)	Radiated emission 30 MHz to 1 GHz	52	Test passed
15.225(e)	Carrier frequency stability	54	Test passed

⁵ See "Spectrum Mask" for the 13.36 to 13.41 MHz band. For all other restricted bands see "Radiated Emission".

IC RSS-GEN Issue 3			
<i>Section(s)</i>	<i>Test</i>	<i>Page</i>	<i>Result</i>
4.8	Transmitter output power (conducted)	32	Recorded
4.6.1	Occupied Bandwidth	33	Recorded
8	Designation of emissions	43	Calculated
4.5	Pulsed operation	---	Not applicable
2.2(a)	Restricted bands and unwanted emission frequencies	--- ⁶	Test passed
7.2.2(b)(c) 7.2.5	Unwanted emissions 9 kHz to 30 MHz	49	Test passed
2.2(b)(c) 7.2.5	Unwanted emissions 30 MHz to 1 GHz	52	Test passed
7.2.2	Transmitter AC power lines conducted emissions 150 kHz to 30 MHz	44	Test passed
5.5	Exposure of Humans to RF Fields	57	Exempted from SAR and RF evaluation

IC RSS-210 Issue 8			
<i>Section(s)</i>	<i>Test</i>	<i>Page</i>	<i>Result</i>
A2.6	Spectrum Mask	45	Test passed
A2.6	Unwanted emissions 9 kHz to 30 MHz	49	Test passed
A2.6	Unwanted emissions 30 MHz to 1 GHz	52	Test passed
A2.6	Carrier frequency stability	54	Test passed

⁶ See "Spectrum Mask" and "Unwanted emissions".

8.1 Conducted Output Power

Rules and specifications:	CFR 47 Part 2, section 2.1046(a) IC RSS-Gen Issue 3, section 4.8
Guide:	CFR 47 Part 2, section 2.1046 / IC RSS-Gen Issue 3
Description:	Conducted output power shall be measured at the RF output terminals (e.g. antenna connector if antenna is detachable) when the transmitter is adjusted in accordance with the tune-up procedure, if applicable. The electrical characteristics of the radio frequency load attached to the output terminals when this test is made shall be stated.
Measurement procedure:	Conducted Output Power (6.1)

Comment:	
Date of test:	2013-08-12
Test site:	Unshielded room

Test Result:	Test passed
--------------	-------------

Antenna gain:	1 dBi						
Mode	Frequency (MHz)	Power Type	Reading (dBm)	Correction (dB)	Output Power (dBm)	Limit (dBm)	Margin (dB)
CW	13,560	PEP	1,0	21,2	22,2		

- Note 1:* If applicable, PEP (peak envelope power) and RMS values are measured using a power meter with appropriate sensor.
- Note 2:* If applicable, peak or average values are measured using a spectrum analyzer with resolution and video bandwidth set to: RBW = 10kHz, VBW = 30 kHz.
- Note 3:* If transmitting antennas of directional gain greater than 6 dBi are used, the conducted output power limit is reduced by the amount in dB that the directional gain of the antenna exceeds 6 dBi.

8.2 Occupied Bandwidth (ANT8)

Rules and specifications:	CFR 47 Part 2, section 2.202(a) ANSI C63.4, annex H.6	
Guide:	ANSI C63.4	
Description:	<p>The occupied bandwidth according to CFR 47 Part 2, section 2.202(a), is measured as the 99% emission bandwidth, i.e. below its lower and above its upper frequency limits, the mean powers radiated are each equal to 0.5% of the total mean power radiated by a given emission.</p> <p>The occupied bandwidth according to ANSI C63.4, annex H.6; is measured as the frequency range defined by the points that are 26 dB down relative to the maximum level of the modulated carrier.</p> <p>The resolution bandwidth of the spectrum analyzer shall be set to a value greater than 5.0% of the allowed bandwidth. If no bandwidth specifications are given, the following guidelines are used:</p>	
	Fundamental frequency	Minimum resolution bandwidth
	9 kHz to 30 MHz	1 kHz
	30 MHz to 1000 MHz	10 kHz
	1000 MHz to 40 GHz	100 kHz
	The video bandwidth shall be at least three times greater than the resolution bandwidth.	
Measurement procedure:	Bandwidth Measurements (6.2)	

Comment:	Tested with ANT8
Date of test:	2013-08-05
Test site:	Fully anechoic room, cabin no. 2

Occupied Bandwidth (99 %):

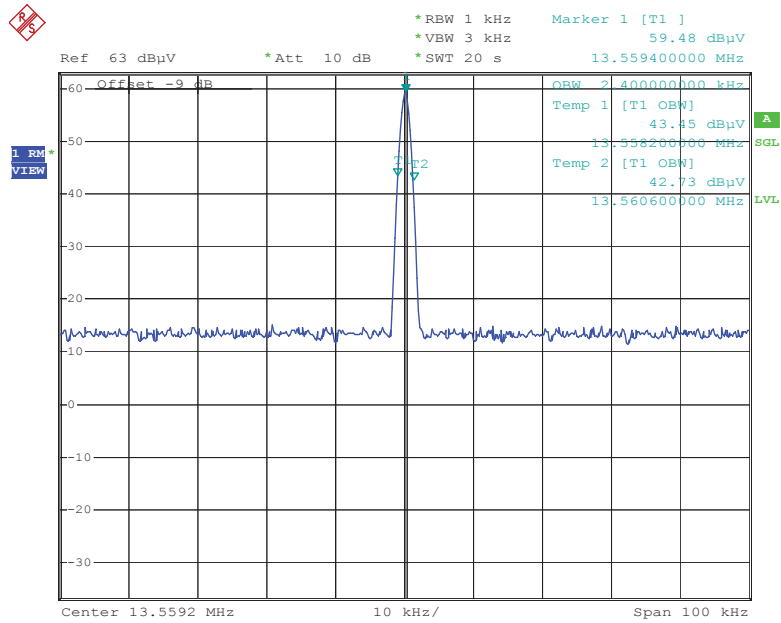

Date: 5.AUG.2013 16:17:49

Occupied Bandwidth (99 %): **2.40 kHz**

Occupied Bandwidth (-26 dB):

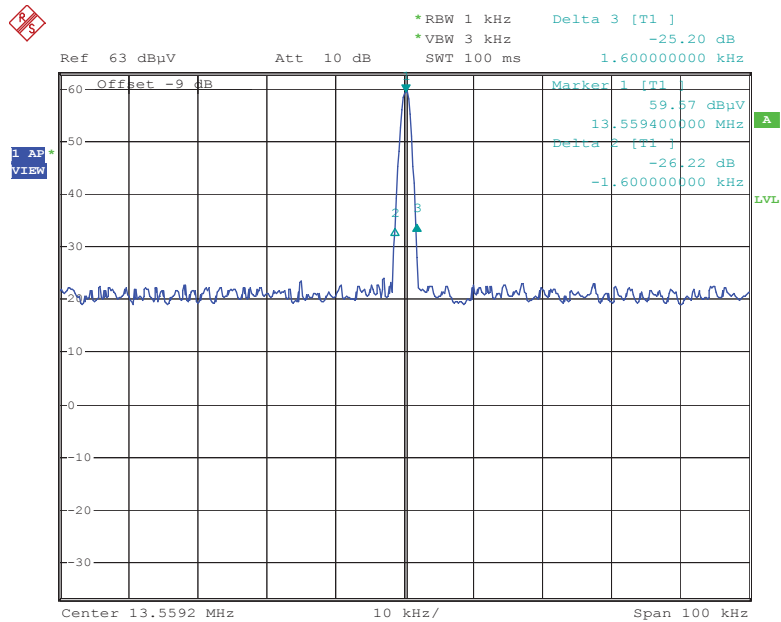

Date: 5.AUG.2013 16:09:09

Occupied Bandwidth (-26 dB): **3.20 kHz**

Occupied Bandwidth (continued)

Rules and specifications:	IC RSS-Gen Issue 3, section 4.6.1
Guide:	IC RSS-Gen Issue 3, section 4.6.1
Description:	<p>If not specified in the applicable RSS the occupied bandwidth is measured as the 99% emission bandwidth.</p> <p>The span of the analyzer shall be set to capture all products of the modulation process, including the emission skirts. The resolution bandwidth shall be set to as close to 1% of the selected span as is possible without being below 1%. The video bandwidth shall be set to 3 times the resolution bandwidth.</p> <p>The trace data points are recovered and are directly summed in linear terms. The recovered amplitude data points, beginning at the lowest frequency, are placed in a running sum until 0.5% of the total is reached and that frequency recorded. The process is repeated for the highest frequency data points. This frequency is also recorded. The span between the two recorded frequencies is the occupied bandwidth.</p>
Measurement procedure:	Bandwidth Measurements (6.2)

Comment:	Tested with ANT 8
Date of test:	2013-08-05
Test site:	Fully anechoic room, cabin no. 2

Occupied Bandwidth (99 %):

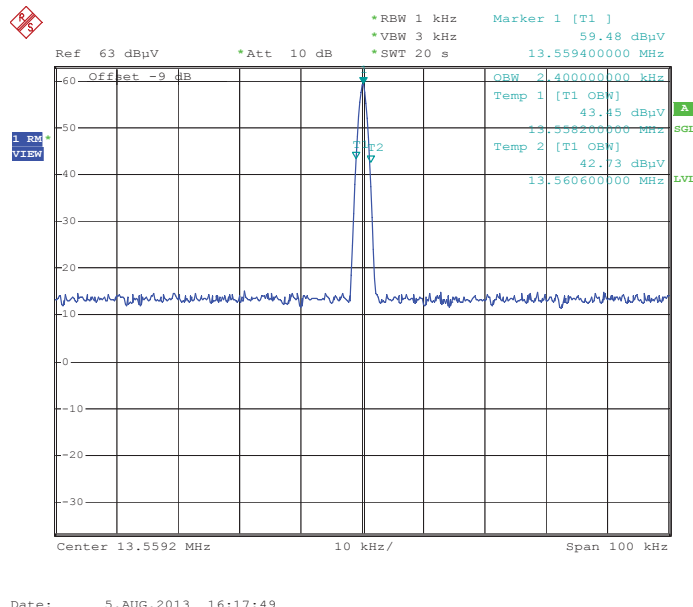

Occupied Bandwidth (99 %):	2.40 kHz
----------------------------	-----------------

8.3 Occupied Bandwidth (ANT30)

Rules and specifications:	CFR 47 Part 2, section 2.202(a) ANSI C63.4, annex H.6	
Guide:	ANSI C63.4	
Description:	<p>The occupied bandwidth according to CFR 47 Part 2, section 2.202(a), is measured as the 99% emission bandwidth, i.e. below its lower and above its upper frequency limits, the mean powers radiated are each equal to 0.5% of the total mean power radiated by a given emission.</p> <p>The occupied bandwidth according to ANSI C63.4, annex H.6; is measured as the frequency range defined by the points that are 26 dB down relative to the maximum level of the modulated carrier.</p> <p>The resolution bandwidth of the spectrum analyzer shall be set to a value greater than 5.0% of the allowed bandwidth. If no bandwidth specifications are given, the following guidelines are used:</p>	
	Fundamental frequency	Minimum resolution bandwidth
	9 kHz to 30 MHz	1 kHz
	30 MHz to 1000 MHz	10 kHz
	1000 MHz to 40 GHz	100 kHz
	The video bandwidth shall be at least three times greater than the resolution bandwidth.	
Measurement procedure:	Bandwidth Measurements (6.2)	

Comment:	Tested with ANT30
Date of test:	2013-08-05
Test site:	Fully anechoic room, cabin no. 2

Occupied Bandwidth (99 %):

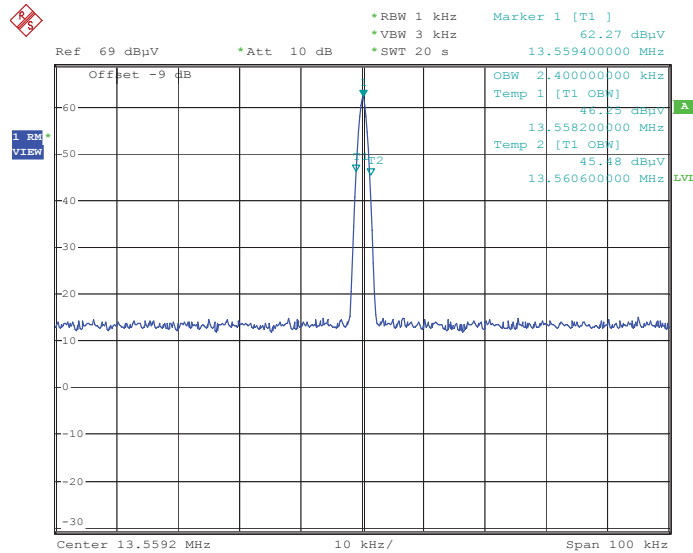

Date: 5.AUG.2013 16:23:38

Occupied Bandwidth (99 %): **2.40 kHz**

Occupied Bandwidth (-26 dB):

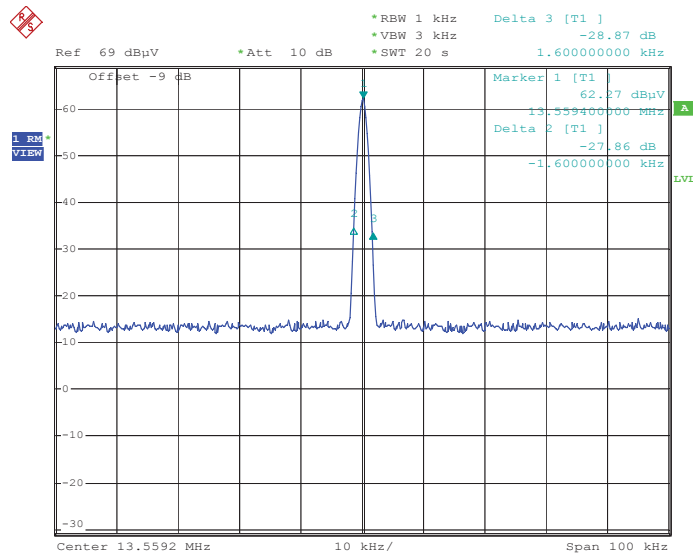

Date: 5.AUG.2013 16:25:09

Occupied Bandwidth (-26 dB): **3.20 kHz**

Occupied Bandwidth (continued)

Rules and specifications:	IC RSS-Gen Issue 3, section 4.6.1
Guide:	IC RSS-Gen Issue 3, section 4.6.1
Description:	<p>If not specified in the applicable RSS the occupied bandwidth is measured as the 99% emission bandwidth.</p> <p>The span of the analyzer shall be set to capture all products of the modulation process, including the emission skirts. The resolution bandwidth shall be set to as close to 1% of the selected span as is possible without being below 1%. The video bandwidth shall be set to 3 times the resolution bandwidth.</p> <p>The trace data points are recovered and are directly summed in linear terms. The recovered amplitude data points, beginning at the lowest frequency, are placed in a running sum until 0.5% of the total is reached and that frequency recorded. The process is repeated for the highest frequency data points. This frequency is also recorded. The span between the two recorded frequencies is the occupied bandwidth.</p>
Measurement procedure:	Bandwidth Measurements (6.2)

Comment:	Tested with ANT30
Date of test:	2013-08-05
Test site:	Fully anechoic room, cabin no. 2

Occupied Bandwidth (99 %):

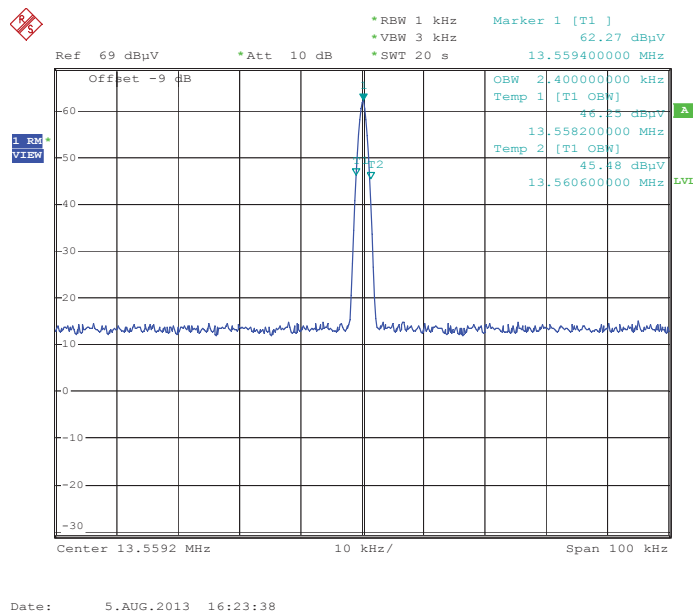

Occupied Bandwidth (99 %):	2.4 kHz
----------------------------	----------------

8.4 Bandwidth of the Emission (ANT8)

Rules and specifications:	CFR 47 Part 15, section 15.215(c)	
Guide:	ANSI C63.4	
Description:	<p>The 20 dB bandwidth of the emission is measured as the frequency range defined by the points that are 20 dB down relative to the maximum level of the modulated carrier.</p> <p>For intentional radiators operating under the alternative provisions to the general emission limits the requirement to contain the 20 dB bandwidth of the emission within the specified frequency band includes the effects from frequency sweeping, frequency hopping and other modulation techniques that may be employed as well as the frequency stability of the transmitter over expected variations in temperature and supply voltage. If a frequency stability is not specified in the regulations, it is recommended that the fundamental emission be kept within at least the central 80% of the permitted band in order to minimize the possibility of out-of-band operation.</p> <p>The resolution bandwidth of the spectrum analyzer shall be set to a value greater than 5.0% of the allowed bandwidth. If no bandwidth specifications are given, the following guidelines are used:</p>	
	Fundamental frequency	Minimum resolution bandwidth
	9 kHz to 30 MHz	1 kHz
	30 MHz to 1000 MHz	10 kHz
	1000 MHz to 40 GHz	100 kHz
The video bandwidth shall be at least three times greater than the resolution bandwidth.		
Measurement procedure:	Bandwidth Measurements (6.2)	

Comment:	Tested with ANT8
Date of test:	2013-08-05
Test site:	Fully anechoic room, cabin no. 2

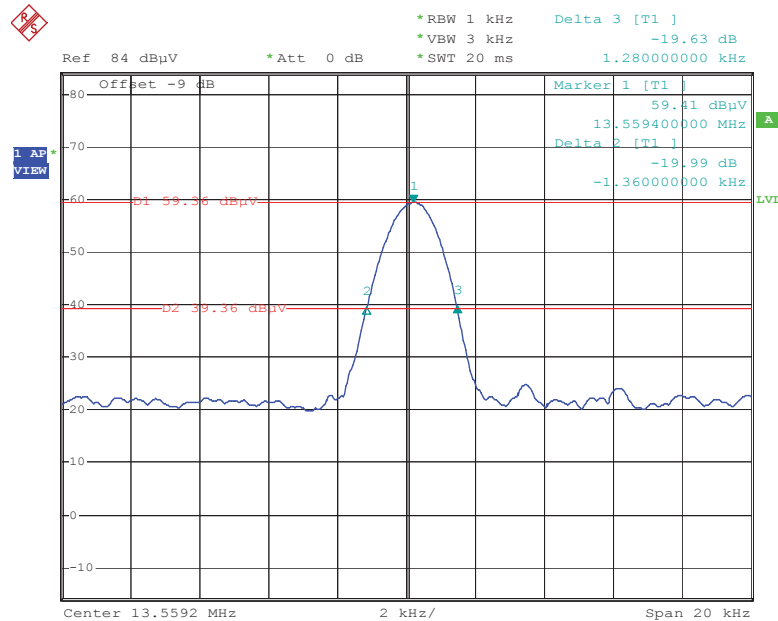

Date: 5.AUG.2013 15:42:26

Permitted frequency band:	13.110 - 14.010 MHz	
20 dB bandwidth:	2.64 kHz	
Carrier frequency stability:	<input checked="" type="checkbox"/> specified	<input type="checkbox"/> not specified
Maximum frequency tolerances Fehler! Hyperlink-Referenz ungültig.:	+0.106 kHz - 0.041 kHz	
Bandwidth of the emission:	2.787 kHz	within permitted frequency band⁷: <input checked="" type="checkbox"/> yes <input type="checkbox"/> no

Test Result:	Test passed
--------------	-------------

⁷ If a frequency stability is not specified, it is recommended that the fundamental emission is kept within at least the central 80% of the permitted band in order to minimize the possibility of out-of-band operation.

8.5 Bandwidth of the Emission (ANT30)

Rules and specifications:	CFR 47 Part 15, section 15.215(c)	
Guide:	ANSI C63.4	
Description:	<p>The 20 dB bandwidth of the emission is measured as the frequency range defined by the points that are 20 dB down relative to the maximum level of the modulated carrier.</p> <p>For intentional radiators operating under the alternative provisions to the general emission limits the requirement to contain the 20 dB bandwidth of the emission within the specified frequency band includes the effects from frequency sweeping, frequency hopping and other modulation techniques that may be employed as well as the frequency stability of the transmitter over expected variations in temperature and supply voltage. If a frequency stability is not specified in the regulations, it is recommended that the fundamental emission be kept within at least the central 80% of the permitted band in order to minimize the possibility of out-of-band operation.</p> <p>The resolution bandwidth of the spectrum analyzer shall be set to a value greater than 5.0% of the allowed bandwidth. If no bandwidth specifications are given, the following guidelines are used:</p>	
	Fundamental frequency	Minimum resolution bandwidth
	9 kHz to 30 MHz	1 kHz
	30 MHz to 1000 MHz	10 kHz
	1000 MHz to 40 GHz	100 kHz
	The video bandwidth shall be at least three times greater than the resolution bandwidth.	
Measurement procedure:	Bandwidth Measurements (6.2)	

Comment:	Tested with ANT30
Date of test:	2013-08-05
Test site:	Fully anechoic room, cabin no. 2

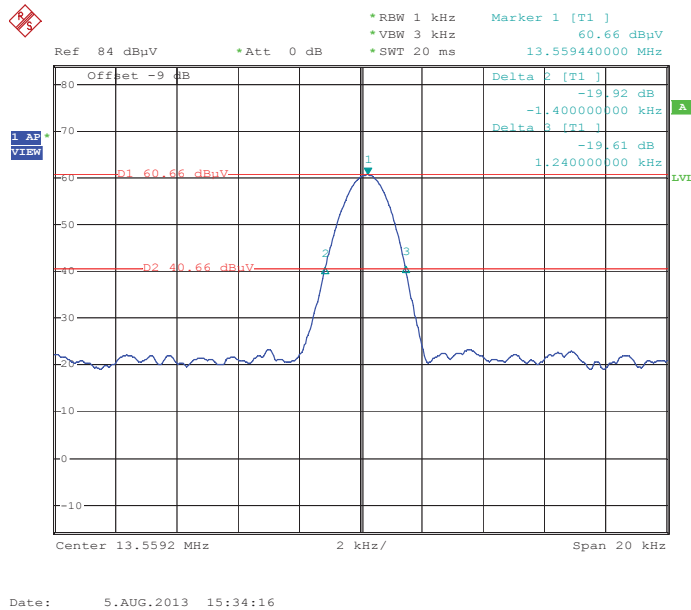

Permitted frequency band:	13.110 - 14.010 MHz	
20 dB bandwidth:	2.64 kHz	
Carrier frequency stability: Maximum frequency tolerances Fehler! Hyperlink-Referenz ungültig.:	<input checked="" type="checkbox"/> specified +0.106 kHz - 0.041 kHz	<input type="checkbox"/> not specified
Bandwidth of the emission:	2.787 kHz	within permitted frequency band⁸: <input checked="" type="checkbox"/> yes <input type="checkbox"/> no

Test Result:	Test passed
--------------	--------------------

⁸ If a frequency stability is not specified, it is recommended that the fundamental emission is kept within at least the central 80% of the permitted band in order to minimize the possibility of out-of-band operation.



8.6 Designation of Emissions

Rules and specifications:	CFR 47 Part 2, sections 2.201 and 2.202 IC RSS-Gen Issue 3, sections 8
Guide:	ANSI C63.4 / TRC-43

Type of modulation:	Amplitude Modulation
---------------------	----------------------

B_n = Necessary Bandwidth	$B_n = 2BK$
B = Modulation rate	B = 1.4 kHz
K = Overall numerical factor	K = 1
Calculation:	$B_n = 2 \cdot (1.4 \text{ kHz}) \cdot 1 = 2.8 \text{ kHz}$

Designation of Emissions:	2k8A1D
---------------------------	---------------

8.7 Conducted Powerline Emission Measurement 150 kHz to 30 MHz

Rules and specifications:	CFR 47 Part 15, section 15.207 IC RSS-GEN Issue 3, section 7.2.4		
Guide:	ANSI C63.4 / CISPR 22		
Limit:	Frequency of Emission (MHz)	Conducted Limit (dBµV)	
		Quasi-peak	Average
	0.15 - 0.5	66 to 56	56 to 46
	0.5 - 5 5 - 30	56 60	46 50
Measurement procedure:	Conducted AC Powerline Emission (6.3)		

Comment:	With dummy load connected to the antenna output terminals
Date of test:	2013-07-17
Test site:	Shielded room, cabin no. 1

Test Result:	Test passed
--------------	-------------

Tested on:	AC power supply port : N
------------	--------------------------

Frequency (MHz)	Detector	Reading Value (dBµV)	Correction Factor (dB)	Final Value (dBµV)	Limit (dBµV)	Margin (dB)
13,560	Quasi-Peak	35,0	0,0	35,0	60,0	25,0
13,560	Average	35,0	0,0	35,0	50,0	15,0

Tested on:	AC power supply port : L1
------------	---------------------------

Frequency (MHz)	Detector	Reading Value (dBµV)	Correction Factor (dB)	Final Value (dBµV)	Limit (dBµV)	Margin (dB)
13,560	Quasi-Peak	38,6	0,0	38,6	60,0	21,4
13,560	Quasi-Peak	38,6	0,0	38,6	50,0	11,4

Sample calculation of final values:

$$\text{Final Value (dBµV)} = \text{Reading Value (dBµV)} + \text{Correction Factor (dB)}$$

8.8 Spectrum Mask (ANT8)

Rules and specifications:	CFR 47 Part 15, section 15.225(a)-(d) IC RSS-210 Issue 8, section A2.6			
Guide:	ANSI C63.4			
Description:	Compliance with the spectrum mask is tested using a spectrum analyzer with resolution bandwidth set to a 1 kHz for the band 13.553 to 13.567 MHz and to 10 kHz outside this band. The video bandwidth shall be at least three times greater than the resolution bandwidth.			
Limit:	Frequency of Emission (MHz)	Field Strength ($\mu\text{V}/\text{m}$)	Field Strength (dB $\mu\text{V}/\text{m}$)	Measurement Distance d (meters)
	1.705 - 13.110	30	29.5	30
	13.110 - 13.410	106	40.5	30
	13.410 - 13.553	334	50.5	30
	13.553 - 13.567	15848	84.0	30
	13.567 - 13.710	334	50.5	30
	13.710 - 14.010	106	40.5	30
	14.010 - 30.000	30	29.5	30
Measurement procedure:	Radiated Emission Measurement 9 kHz to 30 MHz (6.4)			

Comment:	Tested with ANT8
Date of test:	
Test site:	Fully anechoic room, cabin no. 2
Test distance:	3 meters
Extrapolation Factor:	40 dB/decade

Test Result:	Test passed
--------------	-------------

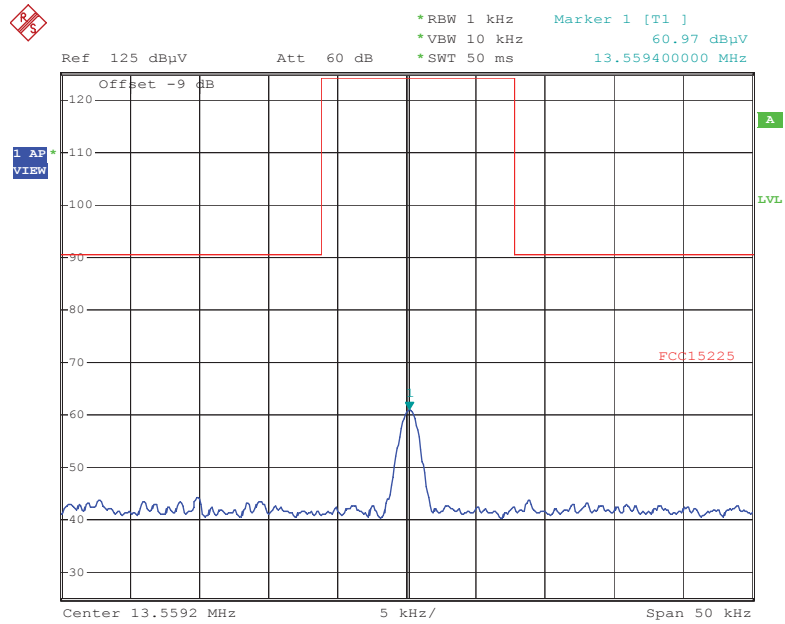
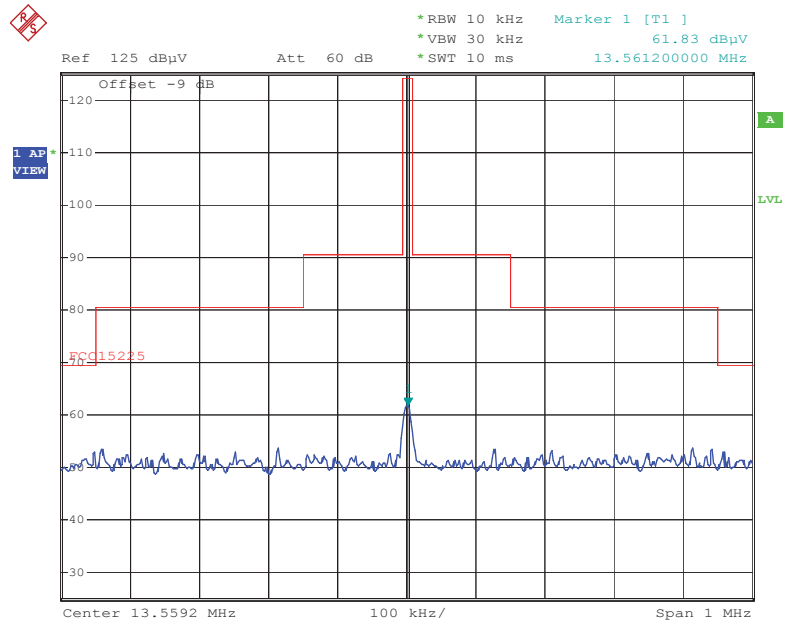



8.9 Spectrum Mask (ANT30)

Rules and specifications:	CFR 47 Part 15, section 15.225(a)-(d) IC RSS-210 Issue 8, section A2.6			
Guide:	ANSI C63.4			
Description:	Compliance with the spectrum mask is tested using a spectrum analyzer with resolution bandwidth set to a 1 kHz for the band 13.553 to 13.567 MHz and to 10 kHz outside this band. The video bandwidth shall be at least three times greater than the resolution bandwidth.			
Limit:	Frequency of Emission (MHz)	Field Strength ($\mu\text{V}/\text{m}$)	Field Strength ($\text{dB}\mu\text{V}/\text{m}$)	Measurement Distance d (meters)
	1.705 - 13.110	30	29.5	30
	13.110 - 13.410	106	40.5	30
	13.410 - 13.553	334	50.5	30
	13.553 - 13.567	15848	84.0	30
	13.567 - 13.710	334	50.5	30
	13.710 - 14.010	106	40.5	30
	14.010 - 30.000	30	29.5	30
Measurement procedure:	Radiated Emission Measurement 9 kHz to 30 MHz (6.4)			

Comment:	Tested with ANT30
Date of test:	
Test site:	Fully anechoic room, cabin no. 2
Test distance:	3 meters
Extrapolation Factor:	40 dB/decade

Test Result:	Test passed
--------------	-------------

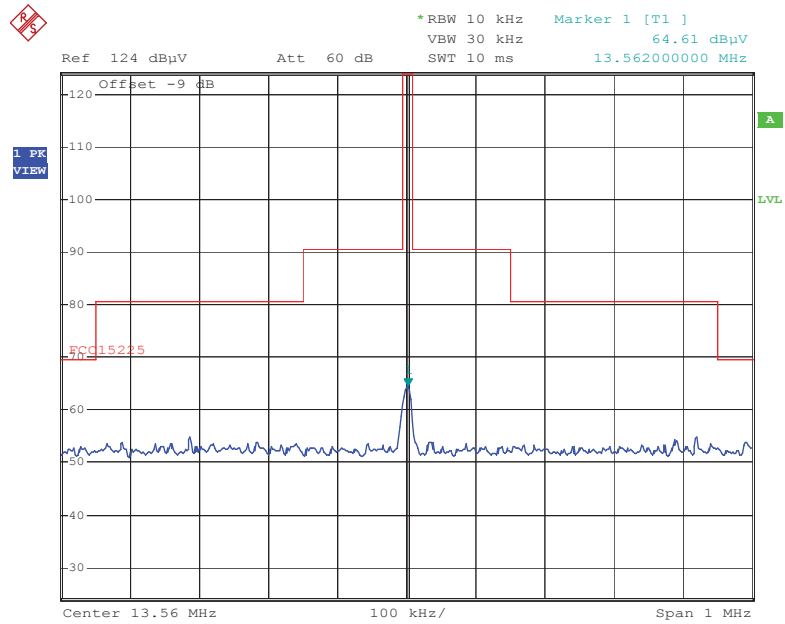

Date: 5.AUG.2013 15:05:57

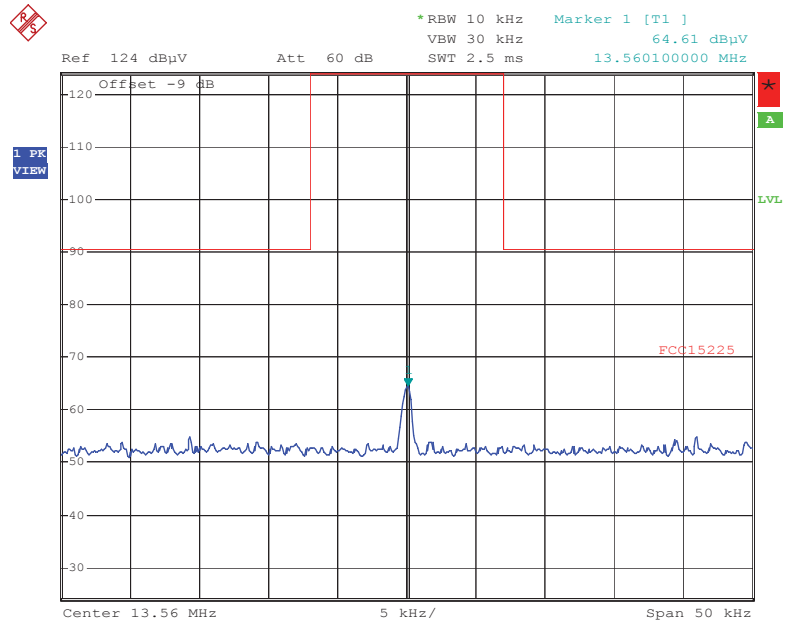

Date: 5.AUG.2013 15:13:36

8.10 Radiated Emission Measurement 9 kHz to 30 MHz (ANT8)

Rules and specifications:	CFR 47 Part 15, sections 15.205 and 15.225(a)-(d) IC RSS-GEN Issue 3, sections 7.2.2(b)(c) and 7.2.5 and IC RSS-210 Issue 8, section A2.6			
Guide:	ANSI C63.4			
Limit:	Frequency of Emission (MHz)	Field Strength ($\mu\text{V}/\text{m}$)	Field Strength ($\text{dB}\mu\text{V}/\text{m}$)	Measurement Distance d (meters)
	0.009 - 0.490	2400/F(kHz)	67.6 - 20 · log(F(kHz))	300
	0.490 - 1.705	24000/F(kHz)	87.6 - 20 · log(F(kHz))	30
	1.705 - 13.110	30	29.5	30
	13.110 - 13.410	106	40.5	30
	13.410 - 13.553	334	50.5	30
	13.553 - 13.567	15848	84.0	30
	13.567 - 13.710	334	50.5	30
	13.710 - 14.010	106	40.5	30
	14.010 - 30.000	30	29.5	30
Additionally, the level of any unwanted emissions shall not exceed the level of the fundamental emission.				
Measurement procedure:	Radiated Emission Measurement 9 kHz to 30 MHz (6.4)			

Comment:	
Date of test:	2013-08-05
Test site:	Open field test site

Test Result:	Test passed
--------------	-------------

Extrapolation factor: -40 dB/decade										
Frequency (MHz)	Detector	Distance		Reading Value ($\text{dB}\mu\text{V}$)	Correction Factor (dB/m)	Extrapolation Factor (dB)	Pulse Train Correction (dB)	Final Value ($\text{dB}\mu\text{V}/\text{m}$)	Limit ($\text{dB}\mu\text{V}/\text{m}$)	Margin (dB)
		d1 (m)	d (m)							
13,56000	Quasi-Peak	3	30	41,2	20,5	-40,0		21,7	84,0	62,3

8.11 Radiated Emission Measurement 9 kHz to 30 MHz (ANT30)

Rules and specifications:	CFR 47 Part 15, sections 15.205 and 15.225(a)-(d) IC RSS-GEN Issue 3, sections 7.2.2(b)(c) and 7.2.5 and IC RSS-210 Issue 8, section A2.6			
Guide:	ANSI C63.4			
Limit:	Frequency of Emission (MHz)	Field Strength ($\mu\text{V}/\text{m}$)	Field Strength ($\text{dB}\mu\text{V}/\text{m}$)	Measurement Distance d (meters)
	0.009 - 0.490	2400/F(kHz)	67.6 - 20 · log(F(kHz))	300
	0.490 - 1.705	24000/F(kHz)	87.6 - 20 · log(F(kHz))	30
	1.705 - 13.110	30	29.5	30
	13.110 - 13.410	106	40.5	30
	13.410 - 13.553	334	50.5	30
	13.553 - 13.567	15848	84.0	30
	13.567 - 13.710	334	50.5	30
	13.710 - 14.010	106	40.5	30
14.010 - 30.000	30	29.5	30	
Additionally, the level of any unwanted emissions shall not exceed the level of the fundamental emission.				
Measurement procedure:	Radiated Emission Measurement 9 kHz to 30 MHz (6.4)			

Comment:	
Date of test:	2013-08-05
Test site:	Open field test site

Test Result:	Test passed
--------------	-------------

Extrapolation factor: -40 dB/decade										
Frequency (MHz)	Detector	Distance		Reading Value ($\text{dB}\mu\text{V}$)	Correction Factor (dB/m)	Extrapolation Factor (dB)	Pulse Train Correction (dB)	Final Value ($\text{dB}\mu\text{V}/\text{m}$)	Limit ($\text{dB}\mu\text{V}/\text{m}$)	Margin (dB)
		d1 (m)	d (m)							
13,56000	Quasi-Peak	3	30	44,3	20,5	-40,0		24,8	84,0	59,2

Sample calculation of final values:

$$\text{Extrapolation Factor (dB)} = (\text{Log}(d) - \text{Log}(d_1)) \cdot \text{Extrapolation Factor (dB/decade)}$$

$$\text{Final Value (dB}\mu\text{V/m)} = \text{Reading Value } d_1 \text{ (dB}\mu\text{V)} + \text{Correction Factor (dB/m)} \\ + \text{Extrapolation Factor (dB)} + \text{Pulse Train Correction (dB)}$$

Note: Extrapolation factor (dB) and final value (dB μ V/m) are relating to distance d.

8.12 Radiated Emission Measurement 30 MHz to 1 GHz (ANT8)

Rules and specifications:	CFR 47 Part 15, sections 15.205(b) and 15.225(d) IC RSS-GEN Issue 3, sections 7.2.2(b)(c) and 7.2.5 and IC RSS-210 Issue 8, section A2.6		
Guide:	ANSI C63.4		
Limit:	Frequency of Emission (MHz)	Field Strength ($\mu\text{V}/\text{m}$)	Field Strength ($\text{dB}\mu\text{V}/\text{m}$)
	30 - 88	100	40.0
	88 - 216	150	43.5
	216 - 960	200	46.0
	Above 960	500	54.0
	Additionally, the level of any unwanted emissions shall not exceed the level of the fundamental emission.		
Measurement procedures:	Radiated Emission in Fully or Semi Anechoic Room (6.5) Radiated Emission at Alternative Test Site (6.6)		

Comment:	Tested with ANT8
Date of test:	2013-07-23
Test site:	Frequencies ≤ 1 GHz: Semi-anechoic room, cabin no. 8 Frequencies > 1 GHz: Fully anechoic room, cabin no. 2
Test distance:	3 meters

Test Result:	Test passed
--------------	-------------

Frequency MHz	QuasiPeak $\text{dB}\mu\text{V}/\text{m}$	Meas. Time ms	Bandwidth kHz	Height cm	Polarization	Azimuth deg	Corr. dB	Margin dB	Limit $\text{dB}\mu\text{V}/\text{m}$
40.660000	32.3	1000.0	120.000	100.0	V	-43.0	15.5	7.7	40.0
135.580000	31.9	1000.0	120.000	161.0	H	-86.0	10.4	11.6	43.5
162.700000	34.5	1000.0	120.000	170.0	H	50.0	10.2	9.0	43.5

Sample calculation of final values:

$$\text{Reading Value (dB}\mu\text{V)} = \text{Final Value (dB}\mu\text{V}/\text{m)} - \text{Correction Factor (dB/m)}$$

8.13 Radiated Emission Measurement 30 MHz to 1 GHz (ANT30)

Rules and specifications:	CFR 47 Part 15, sections 15.205(b) and 15.225(d) IC RSS-GEN Issue 3, sections 7.2.2(b)(c) and 7.2.5 and IC RSS-210 Issue 8, section A2.6		
Guide:	ANSI C63.4		
Limit:	Frequency of Emission (MHz)	Field Strength ($\mu\text{V/m}$)	Field Strength ($\text{dB}\mu\text{V/m}$)
	30 - 88	100	40.0
	88 - 216	150	43.5
	216 - 960	200	46.0
	Above 960	500	54.0
	Additionally, the level of any unwanted emissions shall not exceed the level of the fundamental emission.		
Measurement procedures:	Radiated Emission in Fully or Semi Anechoic Room (6.5) Radiated Emission at Alternative Test Site (6.6)		

Comment:	Tested with ANT30
Date of test:	2013-07-23
Test site:	Frequencies \leq 1 GHz: Semi-anechoic room, cabin no. 8 Frequencies $>$ 1 GHz: Fully anechoic room, cabin no. 2
Test distance:	3 meters

Test Result:	Test passed
--------------	-------------

Frequency MHz	QuasiPeak $\text{dB}\mu\text{V/m}$	Meas. Time ms	Bandwidth kHz	Height cm	Polarization	Azimuth deg	Corr. dB	Margin dB	Limit $\text{dB}\mu\text{V/m}$
40,660000	37,9	1000,0	120,000	100,0	V	-159,0	15,5	2,1	40,0
67,780000	35,0	1000,0	120,000	100,0	V	-55,0	10,9	5,0	40,0
81,340000	32,6	1000,0	120,000	179,0	V	-22,0	9,9	7,4	40,0
94,900000	37,2	1000,0	120,000	302,0	H	87,0	13,3	6,3	43,5
135,580000	34,8	1000,0	120,000	100,0	V	-66,0	10,4	8,7	43,5
149,140000	32,9	1000,0	120,000	100,0	V	-70,0	9,8	10,6	43,5
162,700000	37,0	1000,0	120,000	100,0	V	11,0	10,2	6,5	43,5
189,820000	38,1	1000,0	120,000	100,0	V	22,0	12,3	5,4	43,5

Sample calculation of final values:

$$\text{Reading Value (dB}\mu\text{V)} = \text{Final Value (dB}\mu\text{V/m)} - \text{Correction Factor (dB/m)}$$

8.14 Carrier Frequency Stability

Rules and specifications:	CFR 47 Part 15, section 15.225(e) IC RSS-Gen Issue 3, section 4.7 and IC RSS-210 Issue 8, section A2.6
Guide:	ANSI C63.4
Limit:	The frequency tolerance of the carrier signal shall be maintained within ± 0.01 % (± 100 ppm) of the carrier frequency under nominal conditions.
Temperature range:	-20°C to +50°C (at normal supply voltage)
Voltage range:	85% to 115% of the rated supply voltage (at a temperature of +20°C)
Measurement procedure:	Carrier Frequency Stability (6.7)

Comment:	
Date of test:	2013-08-07

8.14.1 Carrier Frequency Stability vs. Temperature

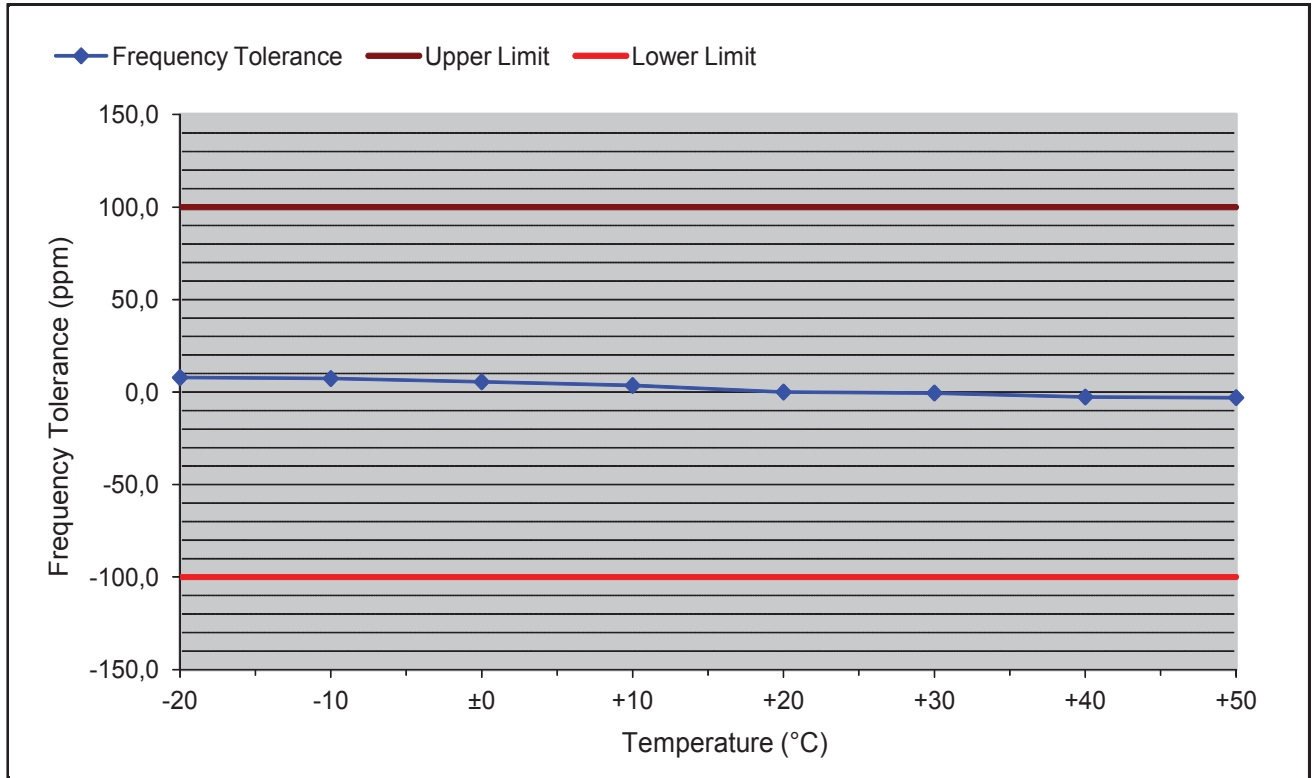

Supply voltage: 24 V Nominal frequency: 13,559410 MHz

Temperature (°C)	Frequency (MHz)	Frequency Tolerance (Hz)	Frequency Tolerance (ppm)	Upper Limit (ppm)	Lower Limit (ppm)	Margin (ppm)
-20	13,559516	106	7,8	+100,0	-100,0	92,2
-10	13,559509	99	7,3	+100,0	-100,0	92,7
±0	13,559485	75	5,5	+100,0	-100,0	94,5
+10	13,559458	48	3,5	+100,0	-100,0	96,5
+20	13,559410	0	0,0	+100,0	-100,0	100,0
+30	13,559403	-7	-0,5	+100,0	-100,0	99,5
+40	13,559374	-36	-2,7	+100,0	-100,0	97,3
+50	13,559369	-41	-3,0	+100,0	-100,0	97,0

Test Result: Test passed

8.14.2 Carrier Frequency Stability vs. Supply Voltage

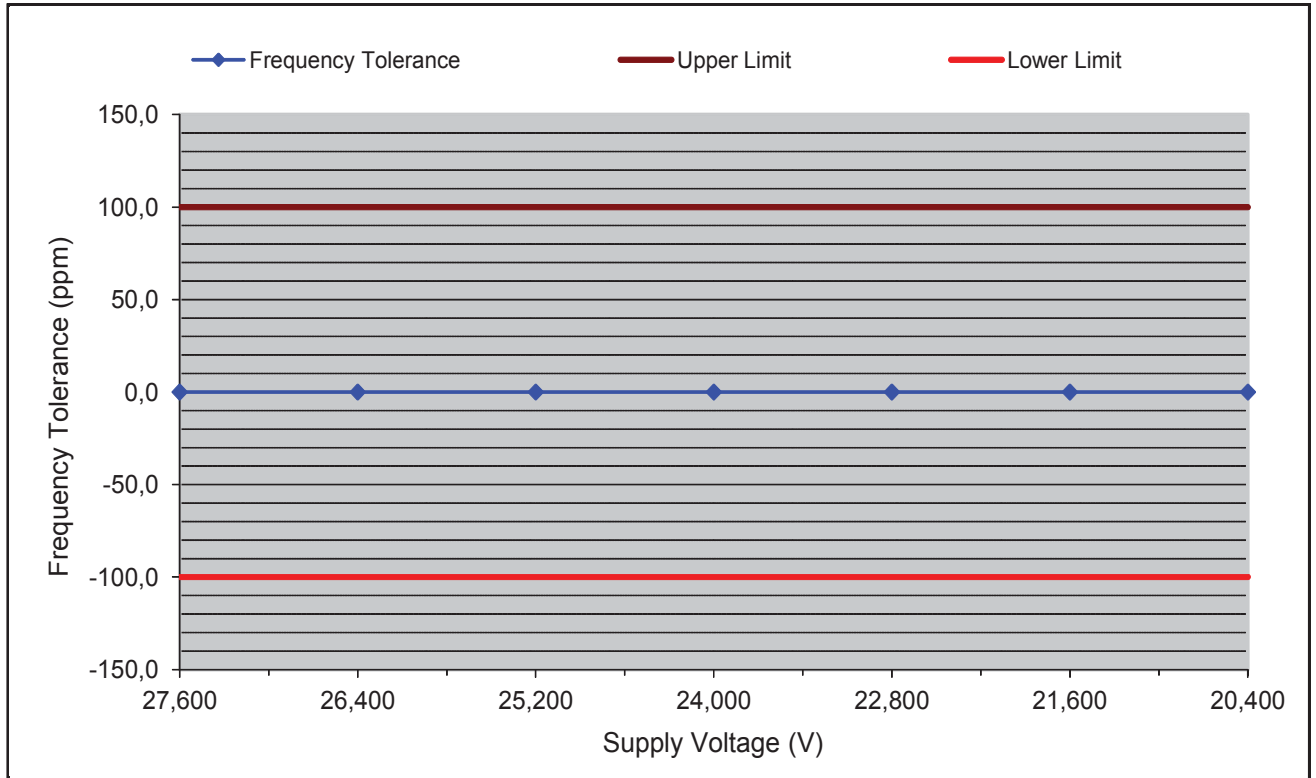

Temperature: +20 °C Battery End Point: Not applicable
 Nominal frequency: 13,559410 MHz

Supply Voltage (V)	Frequency (MHz)	Frequency Tolerance (Hz)	Frequency Tolerance (ppm)	Upper Limit (ppm)	Lower Limit (ppm)	Margin (ppm)
27,600	13,559410	0	0,0	+100,0	-100,0	100,0
26,400	13,559410	0	0,0	+100,0	-100,0	100,0
25,200	13,559410	0	0,0	+100,0	-100,0	100,0
24,000	13,559410	0	0,0	+100,0	-100,0	100,0
22,800	13,559410	0	0,0	+100,0	-100,0	100,0
21,600	13,559410	0	0,0	+100,0	-100,0	100,0
20,400	13,559410	0	0,0	+100,0	-100,0	100,0

Test Result: Test passed

8.15 Exposure of Humans to RF Fields

Rules and specifications:	IC RSS-Gen Issue 3, section 5.6
Guide:	IC RSS-102 Issue 4, section 2.5

Exposure of Humans to RF Fields	Applicable	Declared by applicant	Measured	Exemption
The antenna is				
<input checked="" type="checkbox"/> detachable				
<p>The conducted output power (CP in watts) is measured at the antenna connector:</p> <p style="text-align: center;">$CP = 158 \text{ mW}$</p> <p>The effective isotropic radiated power (EIRP in watts) is calculated using</p> <p><input type="checkbox"/> the numerical antenna gain: $G = \dots\dots\dots$ $EIRP = G \cdot CP \Rightarrow EIRP = \dots\dots\dots \text{ W}$</p> <p><input checked="" type="checkbox"/> the field strength⁹ in V/m: $FS = 1585 \text{ } \mu\text{V/m}$ $EIRP = \frac{(FS \cdot D)^2}{30} \Rightarrow EIRP = 7,536 \text{ nW}$</p> <p>with: Distance between the antennas in m: $D = 3 \text{ m}$</p>			<input type="checkbox"/>	<input type="checkbox"/>
		<input type="checkbox"/>	<input checked="" type="checkbox"/>	<input checked="" type="checkbox"/>

⁹ The conversion formula is valid only for properly matched antennas. In other cases the transmitter output power may have to be measured by a terminated measurement when applying the exemption clauses. If an open area test site is used for field strength measurement, the effect due to the metal ground reflecting plane should be subtracted from the maximum field strength value in order to reference it to free space, before calculating TP.

9 Referenced Regulations

All tests were performed with reference to the following regulations and standards:

<input checked="" type="checkbox"/>	CFR 47 Part 2	Code of Federal Regulations Part 2 (Frequency allocation and radio treaty matters; General rules and regulations) of the Federal Communication Commission (FCC)	October 1, 2012
<input checked="" type="checkbox"/>	CFR 47 Part 15	Code of Federal Regulations Part 15 (Radio Frequency Devices) of the Federal Communication Commission (FCC)	October 1, 2012
<input checked="" type="checkbox"/>	ANSI C63.4	American National Standard for Methods of Measurement of Radio-Noise Emissions from Low-Voltage Electrical and Electronic Equipment in the Range of 9 kHz to 40 GHz	December 11, 2003 (published on January 30, 2004)
<input type="checkbox"/>	ANSI C63.4	American National Standard for Methods of Measurement of Radio-Noise Emissions from Low-Voltage Electrical and Electronic Equipment in the Range of 9 kHz to 40 GHz	June 7, 2009 (published on September 15, 2009)
<input checked="" type="checkbox"/>	RSS-Gen	Radio Standards Specification RSS-Gen Issue 3 containing General Requirements and Information for the Certification of Radiocommunication Equipment, published by Industry Canada	December 2010
<input checked="" type="checkbox"/>	RSS-210	Radio Standards Specification RSS-210 Issue 8 for Low Power Licence-Exempt Radiocommunication Devices (All Frequency Bands): Category I Equipment, published by Industry Canada	December 2010
<input type="checkbox"/>	RSS-310	Radio Standards Specification RSS-310 Issue 3 for Low-power Licence-exempt Radiocommunication Devices (All Frequency Bands): Category II Equipment, published by Industry Canada	December 2010
<input checked="" type="checkbox"/>	RSS-102	Radio Standards Specification RSS-102 Issue 4: Radio Frequency (RF) Exposure Compliance of Radiocommunication Apparatus (All Frequency Bands), published by Industry Canada	March 2010, footnote 13 updated December 2010
<input type="checkbox"/>	ICES-003	Interference-Causing Equipment Standard ICES-003 Issue 4 for Digital Apparatus, published by Industry Canada	February 7, 2004
<input checked="" type="checkbox"/>	CISPR 22	Third Edition of the International Special Committee on Radio Interference (CISPR), Pub. 22, "Information Technology Equipment – Radio Disturbance Characteristics – Limits and Methods of Measurement"	1997



<input type="checkbox"/>	CAN/CSA- CEI/IEC CISPR 22	Limits and Methods of Measurement of Radio Disturbance Characteristics of Information Technology Equipment	2002
		CAN/CSA CISPR 22-10 Information technology equipment - Radio disturbance characteristics - Limits and methods of measurement (Adopted IEC CISPR 22:2008, sixth edition, 2008-09)	
<input type="checkbox"/>	CAN/CSA CISPR 22-10	Information technology equipment - Radio disturbance characteristics - Limits and methods of measurement (Adopted IEC CISPR 22:2008, sixth edition, 2008-09)	2010
<input checked="" type="checkbox"/>	TRC-43	Notes Regarding Designation of Emissions (Including Necessary Bandwidth and Classification), Class of Station and Nature of Service, published by Industry Canada	October, 2008

10 Test Equipment List with Calibration Data

Type	Inv.-No.	Type Designation	Serial Number	Manufacturer	Calibration Organization	Last Calibration	Next Calibration
EMI test receiver	1028	ESHS10	860043/016	Rohde & Schwarz	Rohde & Schwarz	03/2013	09/2014
EMI test receiver	1711	ESPI7	836914/0002	Rohde & Schwarz	Rohde & Schwarz	11/2012	05/2014
EMI test receiver	2044	ESU8	100232	Rohde & Schwarz	Rohde & Schwarz	07/2012	01/2014
Spectrum analyser	1666	FSP30	100063	Rohde & Schwarz	Rohde & Schwarz	11/2012	05/2014
V-network	1059	ESH3-Z5	894785/005	Rohde & Schwarz	Rohde & Schwarz	08/2011	08/2013
Loop antenna	1016	HFH2-Z2	882964/0001	Rohde & Schwarz	Rohde & Schwarz	11/2012	05/2014
TRILOG Broadband Antenna	1802	VULB 9163	9163-214	Schwarzbeck	Rohde & Schwarz	05/2013	11/2014
TRILOG Broadband Antenna	2058	VULB 9163	9163-408	Schwarzbeck	Rohde & Schwarz	11/2012	05/2014
Temperature test chamber	1271	HT 4010	07065550	Heraeus	TÜV SÜD PS-EMC-STR	06/2013	06/2015
DC power supply	1267	NGSM 32/10	203	Rohde & Schwarz		see note 4	

- Note 1: No calibration required.
 Note 2: Not calibrated separately but with the whole test system when recording calibration data.
 Note 3: No calibration required. Devices are checked before use.
 Note 4: No calibration required. Devices are checked by calibrated equipment during test.



11 Revision History

Revision History			
<i>Edition</i>	<i>Date</i>	<i>Issued by</i>	<i>Modifications</i>
1	2013-09-13	T. Eberl (aw)	First Edition

Annex A Charts taken during testing

Conducted Emission Test 150 kHz - 30 MHz according to FCC Part 15 Subpart C	
Model: RF 250 R	Mode: - DC 24 V via plug in power supply - With load 50 R at antenna port - Transmitting continuously - RS422 IF version
Serial no.: ---	
Applicant: Siemens AG - Fürth	
Test site: Shielded room, cabin no. 4	
Tested on: Linecord AC power supply Phase N	
Date of test: 07/17/2013	Operator: T. Eberl
Test performed: automatically	File name:
Detector: Peak / Final Results: QP	Final results: Selected by hand

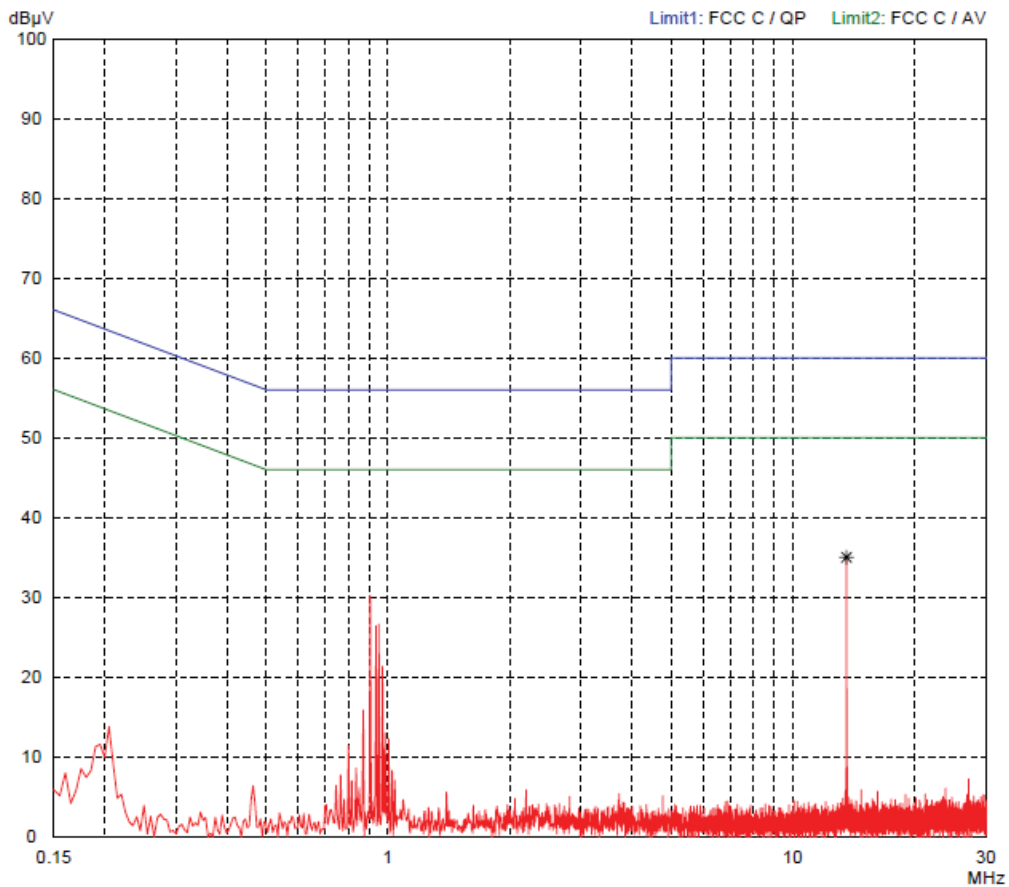

Conducted Emission Test 150 kHz - 30 MHz according to FCC Part 15 Subpart C	
Model: RF 250 R Serial no.: --- Applicant: Siemens AG - Fürth Test site: Shielded room, cabin no. 4 Tested on: Linecord AC power supply Phase L1 Date of test: 07/17/2013 Operator: T. Eberl Test performed: automatically File name:	Mode: - DC 24 V via plug in power supply - With load 50 R at antenna port - Transmitting continuously - RS422 IF version
Detector: Peak / Final Results: QP	Final results: Selected by hand

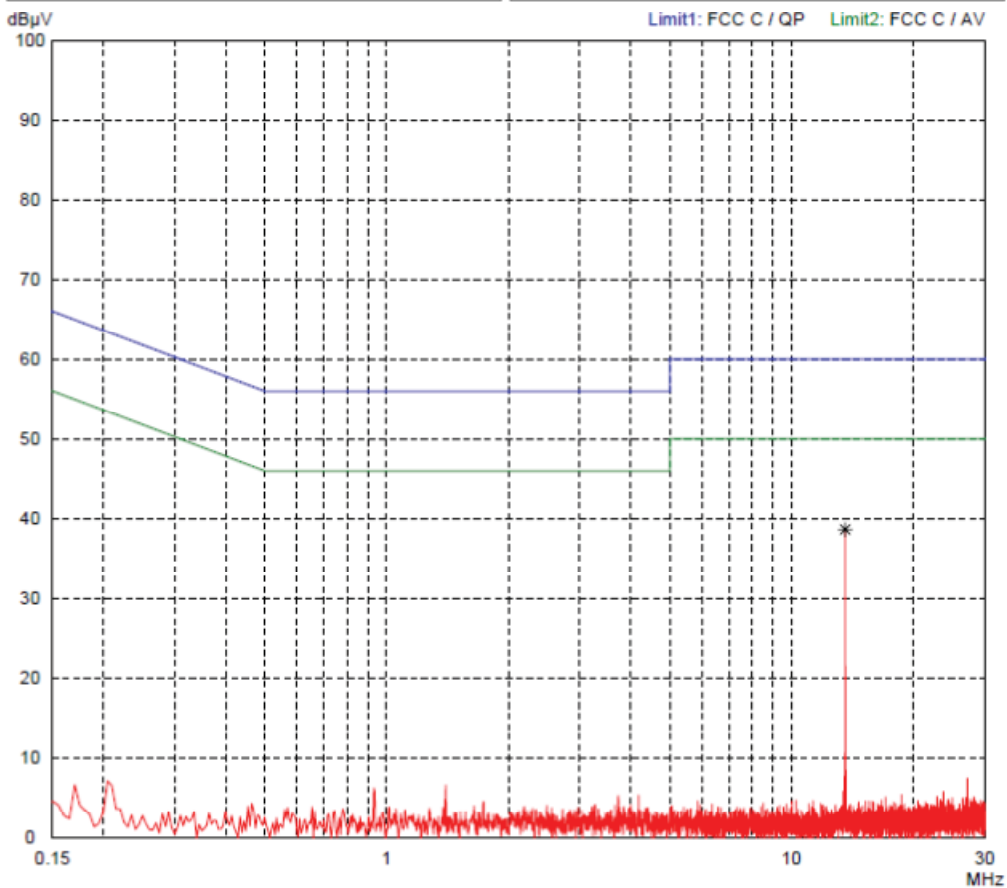

Radiated Emission Measurement 9 kHz – 30 MHz

Comment:	Tested with ANT8
Date of test:	2013-08-06
Test site:	Open field test site (Test distance : 3m)

Test Result:	Test passed
--------------	-------------

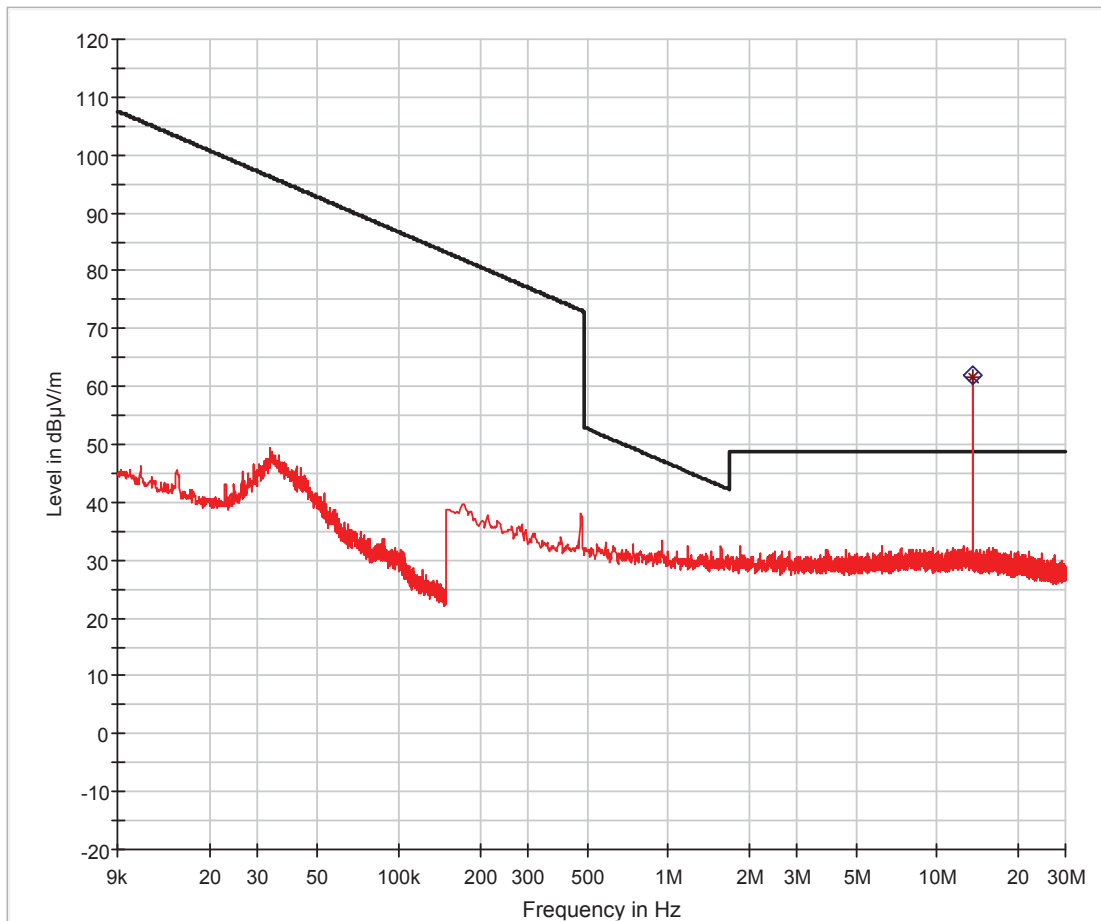

— FCC 15.209 mag (10 m) — Preview Result 1-PK+
* Final Result 1-QPK ◇ Final Result 2-PK+

Radiated Emission Measurement 9 kHz – 30 MHz

Comment:	Tested with ANT30
Date of test:	2013-08-06
Test site:	Open field test site (Test distance : 3m)

Test Result:	Test passed
--------------	-------------

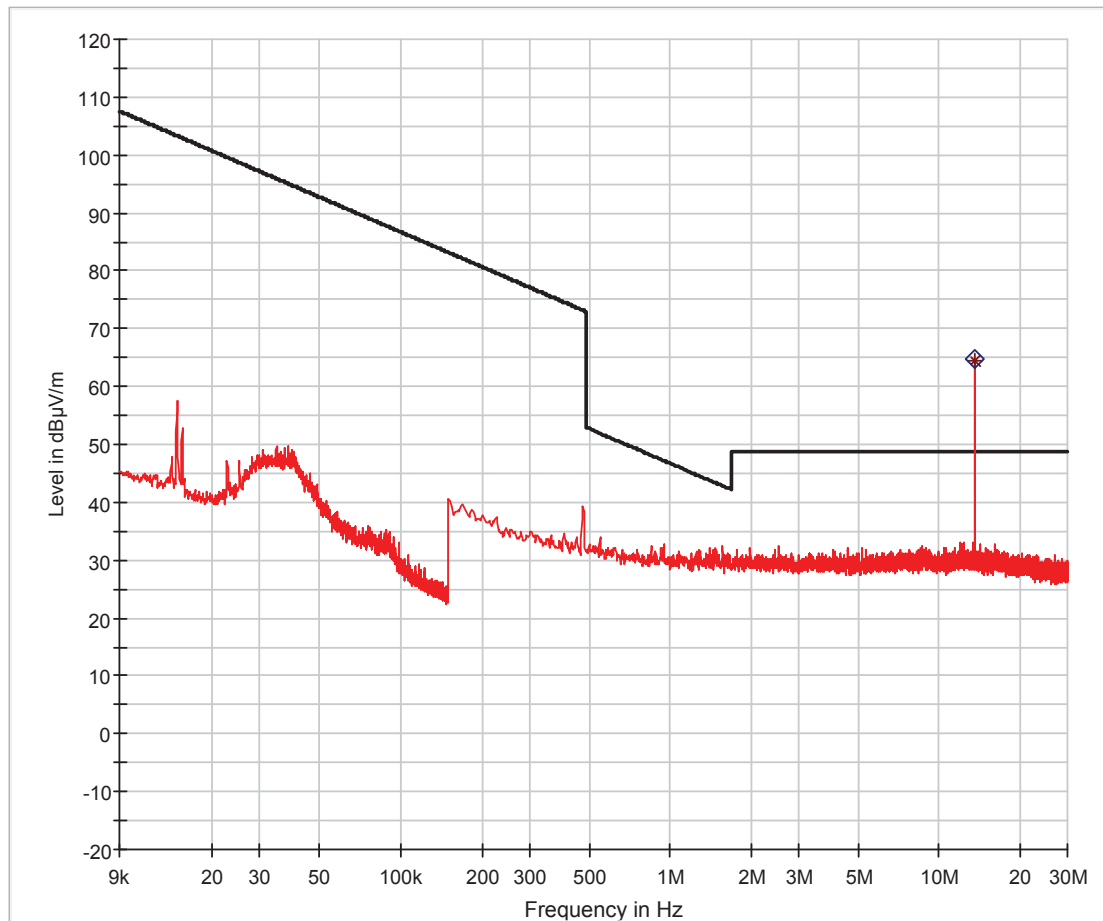

— FCC 15.209 mag (10 m) — Preview Result 1-PK+
* Final Result 1-QPK ◊ Final Result 2-PK+

Radiated Emission Measurement 30 MHz – 1000 MHz

Comment:	Tested with ANT8
Date of test:	2013-08-06
Test site:	Semi-anechoic room, cabin no. 8 (Test distance : 3m)

Test Result:	Test passed
--------------	-------------

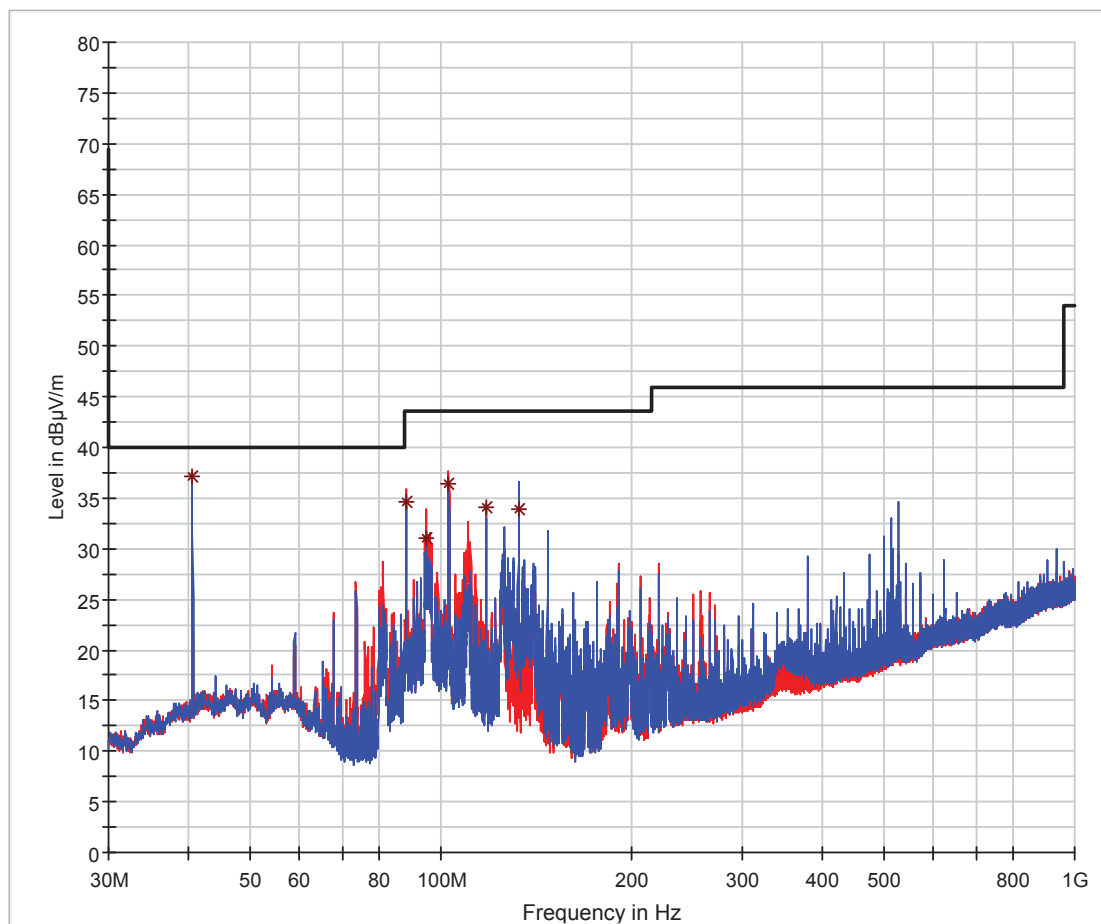

— FCC 15.209
— Preview Result 1V-PK+ * Preview Result 1H-PK+
* Final Result 1-QPK

Radiated Emission Measurement 30 MHz – 1000 MHz

Comment:	Tested with ANT30
Date of test:	2013-08-06
Test site:	Semi-anechoic room, cabin no. 8 (Test distance : 3m)

Test Result:	Test passed
--------------	-------------

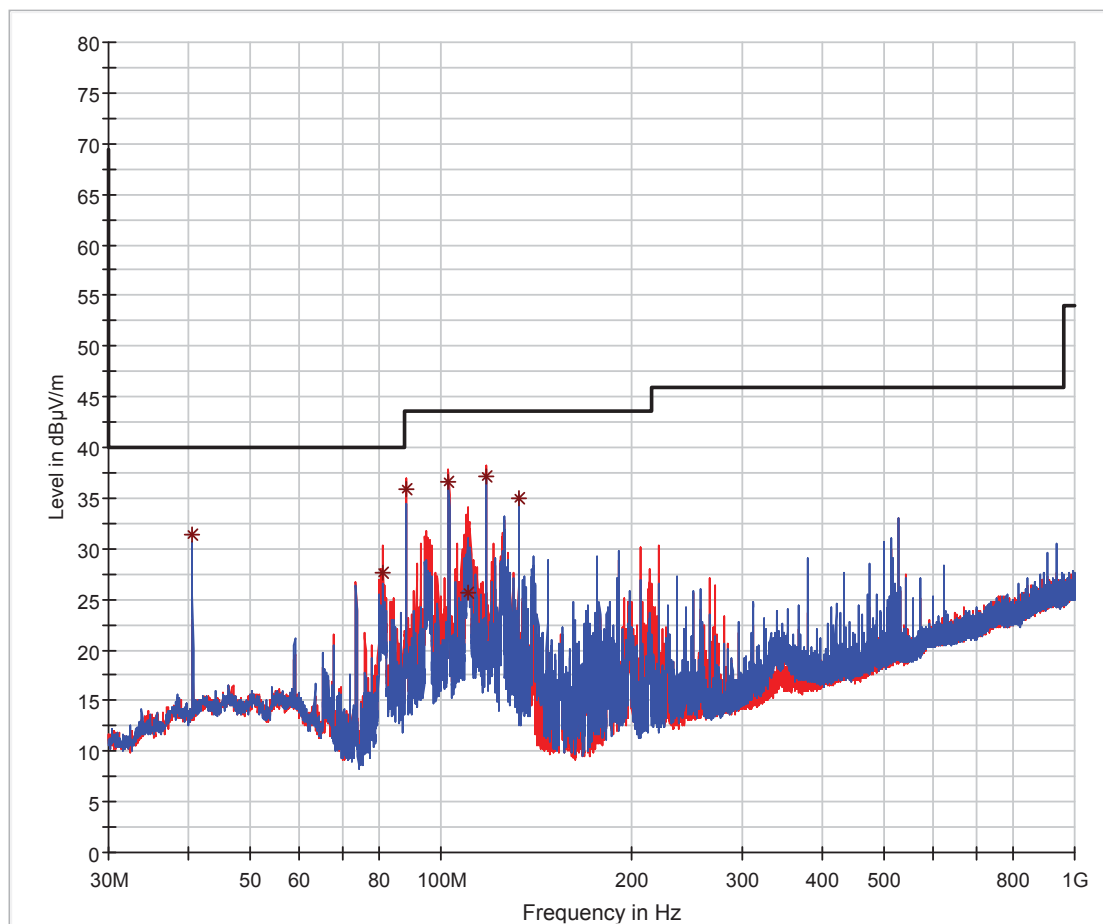

— FCC 15.209
— Preview Result 1V-PK+
— Preview Result 1H-PK+
* Final Result 1-QPK