

TEST SETUP

The test system used to take the conducted data for this report is automated. The shaded components are common to every test and the measurement determines the signal flow from the switch. All path losses are included in the measurements. The UUT is placed in the chamber and the cables are run into it through ports. All dark Lines are RF paths and light lines are audio and DC lines.

RF POWER OUTPUT

Pursuant to FCC Rules 2.985 (a)

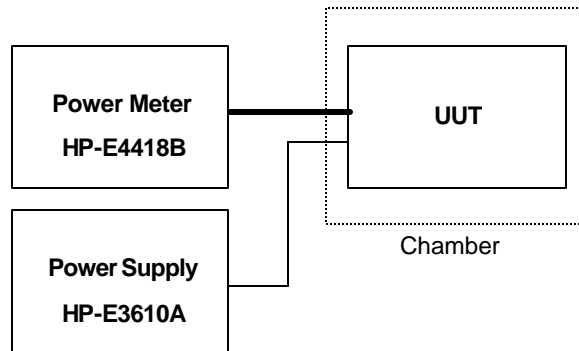

Test Setup for Power Output

Method of Measurement

The RF power output is measured with the transmitter adjusted in accordance with the tune-up procedure to give the value of voltage and current specified in the operation description as required by 2.983(d) (5). A 50-ohm RF attenuator of proper power rating was used as a load for making these measurements. This Transmitter has output impedance of 50 ohms at the radio output. The power measurements are made using a HP-E4418B power meter and 20dB attenuator.

Minimum Standard

The specifications met are per IS137-A Tables 3.2.1-1 and 3.2.2-1.

AUDIO FREQUENCY RESPONSE

Pursuant FCC Rules 2.987 (a)

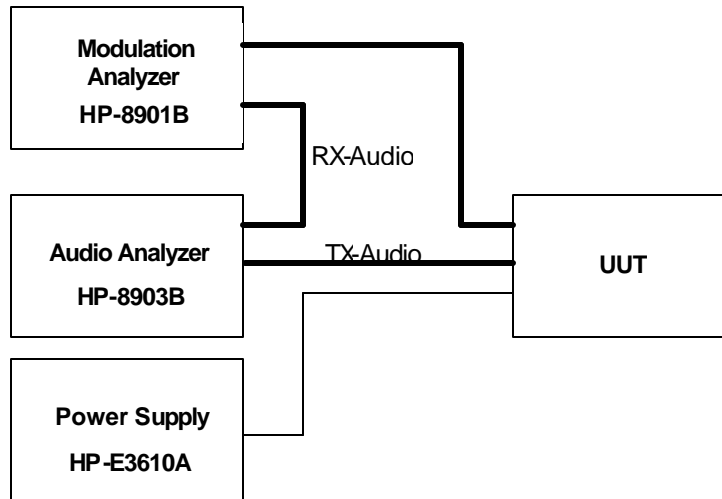

Test Setup for Audio Frequency Response

Method of Measurement

Operate the transmitter under standard test conditions and monitor the output with a calibrated test receiver. With 1004 Hz sine wave audio input applied through a dummy microphone circuit adjust the audio input to give 30% of full rated system deviation. Maintaining constant input, vary the input frequency from 100 to 5000 Hz, and observe the level of modulation measured.

Minimum Standard

The audio frequency response shall not vary more than +1 or -3 dB from 300 to 3000 Hz as referenced to 1000 Hz level (with the exception of a permissible 6 dB/octave roll off from 2500 to 3000 Hz)

POST LIMITER FILTER FREQUENCY RESPONSE

Pursuant FCC Rules 2.987 (a)

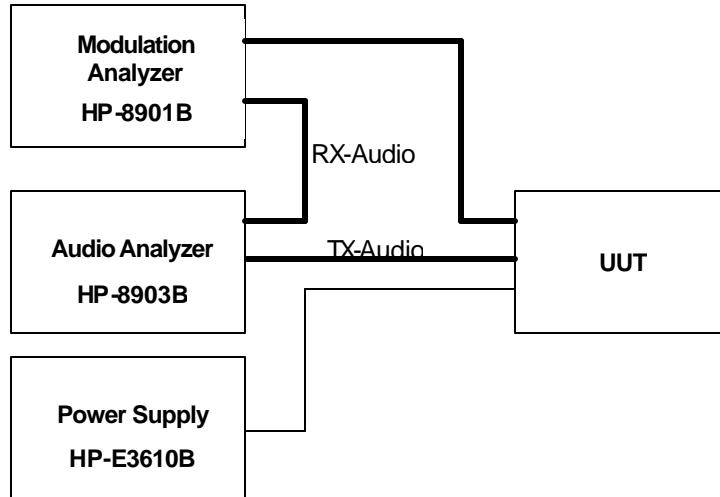

Test Setup for Audio Frequency Response

Method of Measurement

Operate the transmitter under standard test conditions and monitor the demodulated output of a calibrated test receiver with a HP-8903B Audio Analyzer through a HP-8901B Modulation Analyzer. With a reference of a 1004 Hz sine wave audio input from the HP-8903B applied through a dummy microphone circuit and then adjusted to give 8 kHz system deviation, the level is increased by 20 dB. Maintaining that constant input, vary the input frequency from 3 to 30 kHz, and observe the level of the input frequency measured on the HP-8903B.

Minimum Standard

Frequencies between 3 kHz and 20 kHz shall be attenuated greater than the attenuation at 1 kHz by $60 \log_{10} (f/3)$ dB. Frequencies above 20 kHz shall be attenuated at least 50 dB.

MODULATION LIMITING

Pursuant FCC Rules 2.987 (b)

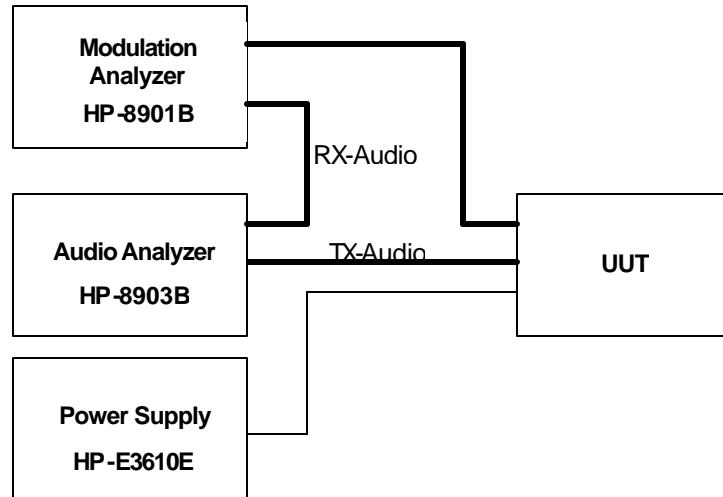

Test Setup for Audio Frequency Response

Method of Measurement

The transmitter shall be adjusted for full rated system deviation. Adjust the audio input for 60% of rated system deviation at 1000 Hz. Using this level as a reference (0 dB) vary the audio input level from the reference to a level 20 dB above it for modulation frequencies of 300, 1000 and 2500 Hz. Record the system deviation obtained as a function of the input level.

FCC Limits

Minimum Standard - The transmitter modulation must not exceed rated system deviation at any audio frequency input or reasonable change in input level.

OCCUPIED BANDWIDTH

Pursuant to FCC Rules 2.989

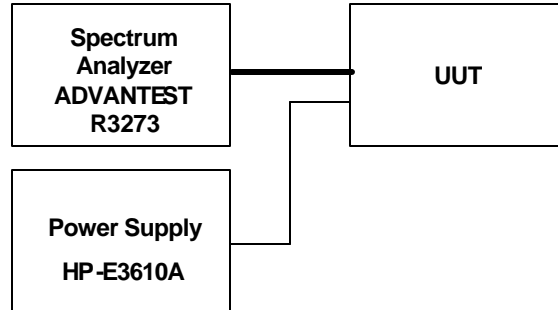

Test Setup for Occupied Band Width

Method of Measurement

Data on occupied bandwidth is presented in the form of a spectrum analyzer photograph that illustrates the transmitter sidebands. The unmodulated carrier is used for reference and the spectrum analyzer is set to the center with a 0 dBc at the top of the screen. Each plot is superimposed with the proper modulation activated. For any display generated by modulating the carrier, an audio a 2500 Hz tone at a level 16 dB greater than that required to produce 50 percent modulation. If a signaling tone is present, photographs using both the tone and the signal tone are used to modulate the transmitter.

FCC Limits - Per Applicable Rule Parts.

Measured Data:

For F3E Voice Mode & F3D Signaling Tone Measurements

Minimum Standard: The mean power of emissions from the transmitter with modulated carrier shall be attenuated below the mean power of the unmodulated carrier in accordance with the schedule below.

- (1) On any frequency removed from the carrier frequency by more than 20 kHz up to and including 45 kHz: At least 26 dB.
- (2) On any frequency removed from the carrier frequency by more than 45 kHz up to $2f$: At least 60 dB or $43 + 10 \text{ Log}(\text{mean output power in watts})$ dB, whichever is the less stringent.

For F1D Wideband Data Mode Measurements

- (1) On any frequency removed from the carrier frequency by more than 20 kHz up to and including 45 kHz: At least 26 dB.
- (2) On any frequency removed from the carrier frequency by more than 45 kHz up to and including 90 kHz: At least 45 dB.

(3) On any frequency removed from the carrier frequency by more than 90 kHz up to 2f: At least 60 dB or $43+10 \text{ Log}$ (mean output power in watts) dB, whichever is less stringent.

RADIATED SPURIOUS EMISSIONS

Pursuant to FCC Rules 2.993

Test Site:

All information and methods are in a separate report issues by **PCTEST** an independent lab contracted to do this measurement.

FCC Limits – Per Applicable Rule Parts.

Radiated spurious emissions shall be attenuated below the maximum level of emission of the carrier frequency in accordance with the following formula: Spurious attenuation in dB = $43 + 10 \log_{10}$ (Power output in watts)

RADIATED POWER

Pursuant to FCC Rules 22.913(a) & 24.232

Test Site & method:

All information and methods are in a separate report issues by PCTEST an independent lab contracted to do this measurement.

FCC Limits – Per Applicable Rule Parts.

That no power level exceeds 600 mW ERP for part 22 and 2000 mW EIRP for part 24.

CONDUCTED SPURIOUS EMISSIONS

Pursuant to FCC Rule 2.991

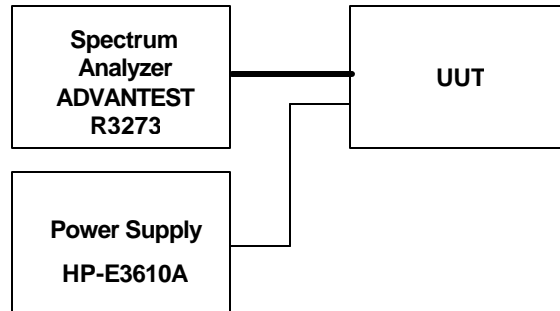

Test Setup for Conducted Spurious Emissions

Method of Measurement:

The transmitter is terminated into a 50-ohm load and interfaced with a spectrum analyzer that allows the spurious emission level relative to the carrier level to be measured directly. Modulate the transmitter with a 2500 Hz sine wave at an input level 16 dB greater than that required to produce 50% of rated system deviation at 1000 Hz.

Measurements shall be made from the lowest radio frequency generated in the equipment to the tenth harmonic of the carrier or as high as the state of the art permits except for that region close to the carrier equal to + 250% of the authorized bandwidth.

For digital radios a pseudo random data pattern should be transmitted.

FCC Limits: Per Applicable Rule Parts.

Conducted spurious emissions shall be attenuated below the maximum level of emission of the carrier frequency in accordance with the following formula:

Spurious attenuation in dB = $43 + 10 \log_{10} (\text{Power output in watts})$ and in the Tx Mobile Band no spurs shall exceed -80 dBm.

FREQUENCY STABILITY

Pursuant to FCC Rule 2.995(a, d)

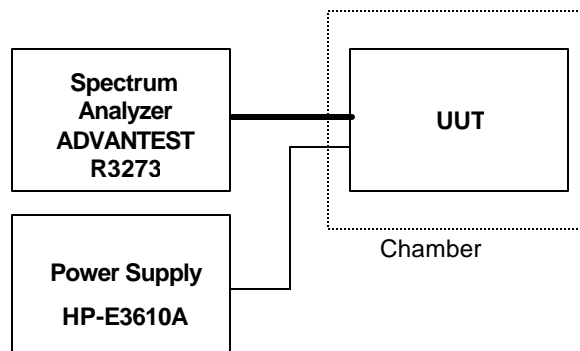

Test Setup for Frequency Stability

Method of Measurement:

A. Temperature (Non-heated type crystals oscillators):

Frequency measurements are made at the extremes of the temperature range –30 to +60 degrees centigrade and at intervals of not more than 10 degrees centigrade through out the range. Sufficient time is allowed prior to each measurement for the circuit components to stabilize.

B. Power Supply Voltage:

The primary voltage was varied from 85% to 115% of the normal supply voltage. Voltage is measured at the input to the cable normally provided with the equipment, or at the power supply terminals if cables are not normally provided.

FCC Limits – Per 2.995 (1) & (2) and Applicable Rule Parts.

Part 22:

Temperature - +2.5ppm from -30 to +60 degrees centigrade

Power Supply Voltage - +2.5ppm from 85% to 115% of nominal voltage.

Part 24:

Temperature - +200 Hz from -30 to +60 degrees centigrade

Power Supply Voltage - +200 Hz from 85% to 115% of nominal voltage.