

Test Report of FCC CFR 47 Part 15 Subpart C

On Behalf of

Kaba GmbH

FCC-ID: NVIB-WEB9600LEGIC
Product Description: RFID Time Attendance, Access Control, Data Collection Terminal
Model No.: B-web 96 00-Legic
Supplementary Model: Kaba Terminal 96 00, B-web 96 00, Kaba Terminal 96 00 - K5, Kaba Terminal 96 05, Kaba Terminal 96 05 - K5, Kaba Terminal 96 10, Kaba Terminal 96 10 - K5
Brand Name: N/A
Prepared for: Kaba GmbH
Albertstraße 3 Villingen-Schwenningen 78056 Germany
Prepared by: Bontek Compliance Testing Laboratory Ltd
1/F, Block East H-3, OCT Eastern Ind. Zone, Qiaocheng East Road, Nanshan, Shenzhen, China
Tel: 86-755-86337020
Fax: 86-755-86337028
Report No.: BCT14HR305E
Issue Date: August 19, 2014
Test Date: August 7~19, 2014

Tested by:



Jiankuai.Li

Reviewed by:

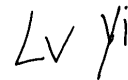

Lv yi

Approved by:

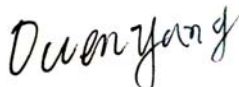

Owen Yang

TABLE OF CONTENTS

1. GENERAL INFORMATION..... 3
1.1 PRODUCT DESCRIPTION FOR EQUIPMENT UNDER TEST (EUT)..... 3
1.2 TEST STANDARDS 4
1.3 TEST FACILITY 4

2. SYSTEM TEST CONFIGURATION 5
2.1 EUT CONFIGURATION 5
2.2 EUT EXERCISE 5
2.3 GENERAL TEST PROCEDURES 5
2.4 MEASUREMENT UNCERTAINTY 5
2.5 TEST EQUIPMENT LIST AND DETAILS 6

3. SUMMARY OF TEST RESULTS 8

4. TEST OF AC POWER LINE CONDUCTED EMISSION 9
4.1 APPLICABLE STANDARD..... 9
4.2 TEST SETUP DIAGRAM 9
4.3 TEST RESULT 9

5. TEST OF RADIATED EMISSION 12
5.1 APPLICABLE STANDARD..... 12
5.2 LIMIT OF RADIATED DISTURBANCES 12
5.3 EUT SETUP 13
5.4 TEST EQUIPMENT LIST AND DETAILS 14
5.5 TEST PROCEDURE 14
5.6 TEST RESULT 15

6. FREQUENCY TOLERANCE 18
6.1 APPLICABLE STANDARD..... 18
6.2 EUT SETUP 18
6.3 TEST EQUIPMENT LIST AND DETAILS 18
6.4 TEST PROCEDURE 18
6.5 TEST RESULT 18

7. ANTENNA REQUIREMENT 20
7.1 STANDARD APPLICABLE..... 20
7.2 ANTENNA CONNECTED CONSTRUCTION 20

1. GENERAL INFORMATION

1.1 Product Description for Equipment Under Test (EUT)

Client Information

Applicant:	Kaba GmbH
Address of Applicant:	Albertstraße 3 Villingen-Schwenningen 78056 Germany
Manufacturer:	DongGuan ZKSoftware Electronic Technology Co.,Ltd
Address of Manufacturer:	No.26,Pingshan 188 Industry zone,Tangxia Town,Dongguan City,Guangdong Province,China 523728

General Description of E.U.T

Items	Description
EUT Description:	RFID Time Attendance, Access Control, Data Collection Terminal
Model No.:	B-web 96 00-Legic
Supplementary Model:	Kaba Terminal 96 00,B-web 96 00, Kaba Terminal 96 00 - K5, Kaba Terminal 96 05, Kaba Terminal 96 05 - K5, Kaba Terminal 96 10, Kaba Terminal 96 10 - K5
Trade Name:	N/A
Transmit Frequency:	13.56MHz
RF Output Power:	33.0dBuA/m 3 meters
Number of Channels:	1
Duty cycle:	100%
Antenna Type:	Built-in Antenna
Power Supply:	Input: DC 48V from POE
Adapter Information:	/

Remark: * The test data gathered are from the production sample provided by the manufacturer.

* Supplementary models have the same circuit, the only difference between 9600-K5, 9605, 9605-K5, 9610 and 9610-K5 is the firmware, running on that devices.

* Products can be no internal RFID reader.

1.2 Test Standards

The tests were performed in order to determine compliance with FCC Part 15, Subpart C, and section 15.207, 15.209 and 15.225 rules. Test was carried out according to the above mentioned FCC rules.

FCC – Registration No.: 970318

Shenzhen CTL Testing Technology Co., Ltd. EMC Laboratory has been registered and fully described in a report filed with the (FCC) Federal Communications Commission. The acceptance letter from the FCC is maintained in our files. Registration 970318, December, 2013.

1.3 Test Facility

All measurement required was performed at laboratory of Bontek Compliance Testing Laboratory Ltd at 1/F, Block East H-3, OCT Eastern Ind. Zone, Qiaocheng East Road, Nanshan, Shenzhen, China.

The test facility is recognized, certified, or accredited by the following organizations:

IC Registration No.: 7631A

The 3m alternate test site of BONTEK COMPLIANCE TESTING LABORATORY LTD. EMC Laboratory has been registered by Certification and Engineer Bureau of Industry Canada for the performance of with Registration NO.: 7631A on January 25, 2011.

CNAS - Registration No.: L3923

BONTEK COMPLIANCE TESTING LABORATORY LTD. to ISO/IEC 17025:25 General Requirements for the Competence of Testing and Calibration Laboratories (CNAS-CL01 Accreditation Criteria for the Competence of Testing and Calibration Laboratories) for the competence in the field of testing. The acceptance letter from the CNAS is maintained in our files: Registration: L3923, March 22, 2012.

2. SYSTEM TEST CONFIGURATION

2.1 EUT Configuration

The EUT configuration for testing is installed on RF field strength measurement to meet the Commissions requirement and operating in a manner that intends to maximize its emission characteristics in a continuous normal application.

2.2 EUT Exercise

The calibrated antennas used to sample the radiated field strength are mounted on a non-conductive, motorized antenna mast 3 or 10 meters from the leading edge of the turntable.

Support equipments or special accessories in test configuration:

AUX Description:	Manufacturer	Model No.	Certificate	CABLE
8-Port 10/100Mbps Desktop POE Switch	TP-LINK	TL-SF1008P	CE, FCC	/

2.3 General Test Procedures

Conducted Emissions: The EUT is placed on the turntable, which is 0.8 m above ground plane. According to the requirements in Section 7.1 of ANSI C63.4-2003 Conducted emissions from the EUT measured in the frequency range between 0.15 MHz and 30MHz using CISPR Quasi-Peak detector mode.

Radiated Emissions: The EUT is a placed on as turntable, which is 0.8 m above ground plane. The turntable shall rotate 360 degrees to determine the position of maximum emission level. EUT is set 3m away from the receiving antenna, which varied from 1m to 4m to find out the highest emission. And also, each emission was to be maximized by changing the polarization of receiving antenna both horizontal and vertical. In order to find out the maximum emissions, exploratory radiated emission measurements were made according to the requirements in Section 13.1.4.1 of ANSI C63.4-2003.

2.4 Measurement Uncertainty

Where relevant, the following measurement uncertainty levels have been estimated for tests performed on the apparatus:

Parameter	Uncertainty
Power Line Conducted Emission	+/- 2.3 dB
Radiated Emission	+/- 3.4 dB

Uncertainty figures are valid to a confidence level of 95%.

2.5 Test Equipment List and Details

Test equipments list of Shenzhen Bontek Compliance Testing Laboratory Co., Ltd.

No.	Instrument no.	Equipment	Manufacturer	Model No.	S/N	Last Calculator	Due Calculator
1	BCT-EMC001	EMI Test Receiver	R&S	ESCI	100687	2014-4-25	2015-4-24
2	BCT-EMC002	EMI Test Receiver	R&S	ESPI	100097	2013-10-31	2014-10-30
3	BCT-EMC003	Amplifier	HP	8447D	1937A02492	2014-4-25	2015-4-24
4	BCT-EMC004	Single Power Conductor Module	R&S	NNBM 8124	242	2014-4-25	2015-4-24
5	BCT-EMC005	Single Power Conductor Module	R&S	NNBM 8124	243	2014-4-25	2015-4-24
6	BCT-EMC006	Power Clamp	SCHWARZBECK	MDS-21	3812	2013-11-4	2014-11-3
7	BCT-EMC007	Positioning Controller	C&C	CC-C-1F	MF7802113	N/A	N/A
8	BCT-EMC008	Electrostatic DisCharging Simulator	TESEQ	NSG437	125	2013-11-1	2014-10-31
9	BCT-EMC009	Fast Transient Burst Generator	SCHAFFNER	MODULA6150	34572	2014-4-25	2015-4-24
10	BCT-EMC010	Fast Transient Noise Simulator	Noiseken	FNS-105AX	10501	2014-6-26	2015-6-25
11	BCT-EMC011	Color TV Pattern Generator	PHILIPS	PM5418	TM209947	N/A	N/A
12	BCT-EMC012	Power Frequency Magnetic Field Generator	EVERFINE	EMS61000-8K	608002	2014-4-25	2015-4-24
14	BCT-EMC014	Capacitive Coupling Clamp	TESEQ	CDN8014	25096	2014-4-25	2015-4-24
15	BCT-EMC015	High Field Biconical Antenna	ELECTRO-METRICS	EM-6913	166	2013-11-27	2014-11-26
16	BCT-EMC016	Log Periodic Antenna	ELECTRO-METRICS	EM-6950	811	2013-11-27	2014-11-26
17	BCT-EMC017	Remote Active Vertical Antenna	ELECTRO-METRICS	EM-6892	304	2013-11-27	2014-11-26
18	BCT-EMC018	TRILOG Broadband Test-Antenna	SCHWARZBECK	VULB9163	9163-324	2014-4-25	2015-4-24
19	BCT-EMC019	Horn Antenna	SCHWARZBECK	BBHA9120A	0499	2013-11-27	2014-11-26
20	BCT-EMC020	Teo Line Single Phase Module	SCHWARZBECK	NSLK8128	8128247	2013-10-31	2014-10-30
21	BCT-EMC021	Triple-Loop Antenna	EVERFINE	LLA-2	711002	2013-11-14	2014-11-13
22	BCT-EMC022	Electric bridge	Jhai	JK2812C	803024	N/A	N/A
23	BCT-EMC026	RF POWER AMPLIFIER	FRANKONIA	FLL-75	1020A1109	2014-4-25	2015-4-24

24	BCT-EMC027	CDN	FRANKONIA	CDN M2+M3	A3027019	2014-4-25	2015-4-24
25	BCT-EMC029	6DB Attenuator	FRANKONIA	N/A	1001698	2014-4-25	2015-4-24
26	BCT-EMC030	EM Injection clamp	FCC	F-203I-23mm	091536	2014-4-25	2015-4-24
27	BCT-EMC031	9kHz-2.4GHz signal generator 2024	MARCONI	10S/6625-99-457-8730	112260/042	2014-4-25	2015-4-24
28	BCT-EMC032	10dB attenuator	ELECTRO-METRICS	EM-7600	836	2014-4-25	2015-4-24
29	BCT-EMC033	ISN	TESEQ	ISN-T800	30301	2013-11-14	2014-11-13
30	BCT-EMC034	10KV surge generator	SANKI	SKS-0510M	048110003E321	2013-10-31	2014-10-30
31	BCT-EMC035	HRMONICS&FLICKRE ANALYSER	VOLTECH	PM6000	200006700433	2013-11-19	2014-11-18
32	BCT-EMC036	Spectrum Analyzer	R&S	FSP	100397	2013-10-31	2014-10-30
33	BCT-EMC037	Broadband preamplifier	SCHWARZBECK	BBV9718	9718-182	2014-4-25	2015-4-24

3. SUMMARY OF TEST RESULTS

FCC Rules	Description of Test	Result
FCC §15.207	AC Power Line Conducted Emission	Pass
FCC §15.225(a)(b)(c)(d)	Radiated Emission (9kHz ~ 30MHz)	Pass
FCC §15.225(d), 15.209	Radiated Emission (30MHz ~ 1GHz)	Pass
FCC §15.225(e)	Frequency stability	Pass

4. TEST OF AC POWER LINE CONDUCTED EMISSION

4.1 Applicable Standard

Refer to FCC §15.207.

For a Low-power Radio-frequency Device is designed to be connected to the AC power line, the radio frequency voltage that is conducted back onto the AC power line on any frequency or frequencies within the band 150 kHz to 30 MHz shall not exceed below limits table.

Frequency Range (MHz)	Limits (dBuV)	
	Quasi-Peak	Average
0.150~0.500	66~56	56~46
0.500~5.000	56	46
5.000~30.00	60	50

4.2 Test Setup Diagram

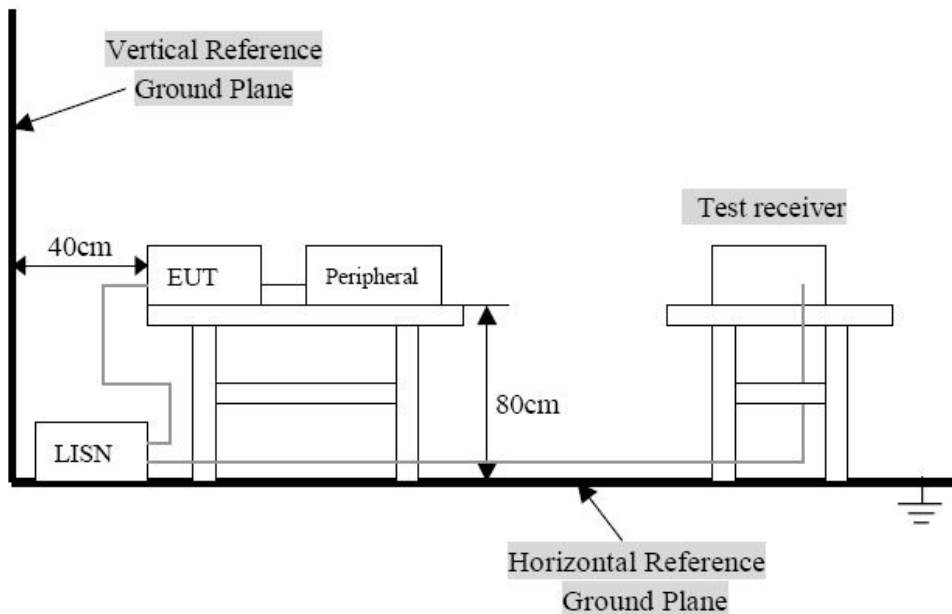

Remark: The EUT was connected to a 120VAC/ 60Hz power source.

4.3 Test Result

Temperature (°C) : 23~25	EUT: RFID Time Attendance, Access Control, Data Collection Terminal
Humidity (%RH) : 45~58	M/N: B-web 96 00-Legic
Barometric Pressure (mbar) : 950~1000	Operation Condition: Normal Operation

Conducted Emission Test Data

EUT: RFID Time Attendance, Access Control, Data Collection Terminal
 Operating Condition: Normal operation
 Test Site: Shielded Room
 Operator: Andy
 Test Specification: AC 120V/60Hz for POE Switch
 Comment: Live Line

SCAN TABLE: "Voltage (150K-30M) FIN"
 Short Description: 150K-30M Voltage

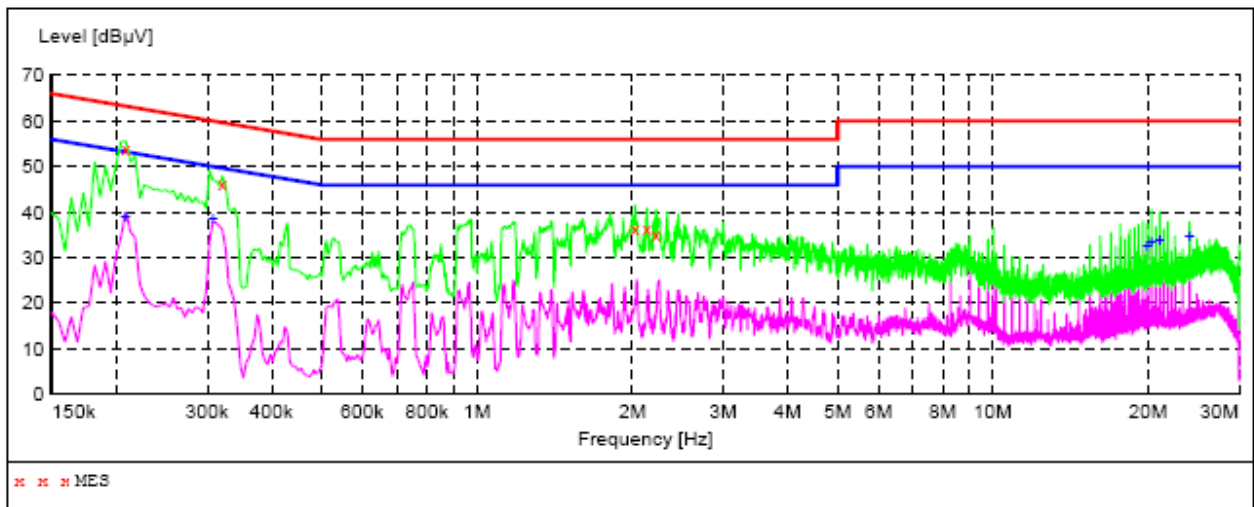

MEASUREMENT RESULT:

Frequency MHz	Level dBµV	Transd dB	Limit dBµV	Margin dB	Detector	Line	PE
0.208500	53.90	11.3	63	9.4	QP	L1	GND
0.321000	46.40	10.9	60	13.3	QP	L1	GND
2.022000	36.40	10.4	56	19.6	QP	L1	GND
2.134500	36.40	10.4	56	19.6	QP	L1	GND
2.224500	35.20	10.4	56	20.8	QP	L1	GND

MEASUREMENT RESULT:

Frequency MHz	Level dBµV	Transd dB	Limit dBµV	Margin dB	Detector	Line	PE
0.208500	39.10	11.3	53	14.2	AV	L1	GND
0.307500	38.60	10.9	50	11.4	AV	L1	GND
19.923000	32.70	10.7	50	17.3	AV	L1	GND
20.301000	33.40	10.7	50	16.6	AV	L1	GND
21.052500	33.70	10.7	50	16.3	AV	L1	GND
24.063000	34.70	10.8	50	15.3	AV	L1	GND

Conducted Emission Test Data

EUT: RFID Time Attendance, Access Control, Data Collection Terminal
 Operating Condition: Normal operation
 Test Site: Shielded Room
 Operator: Andy
 Test Specification: AC 120V/60Hz for POE Switch
 Comment: Neutral Line

SCAN TABLE: "Voltage (150K-30M) FIN"
 Short Description: 150K-30M Voltage

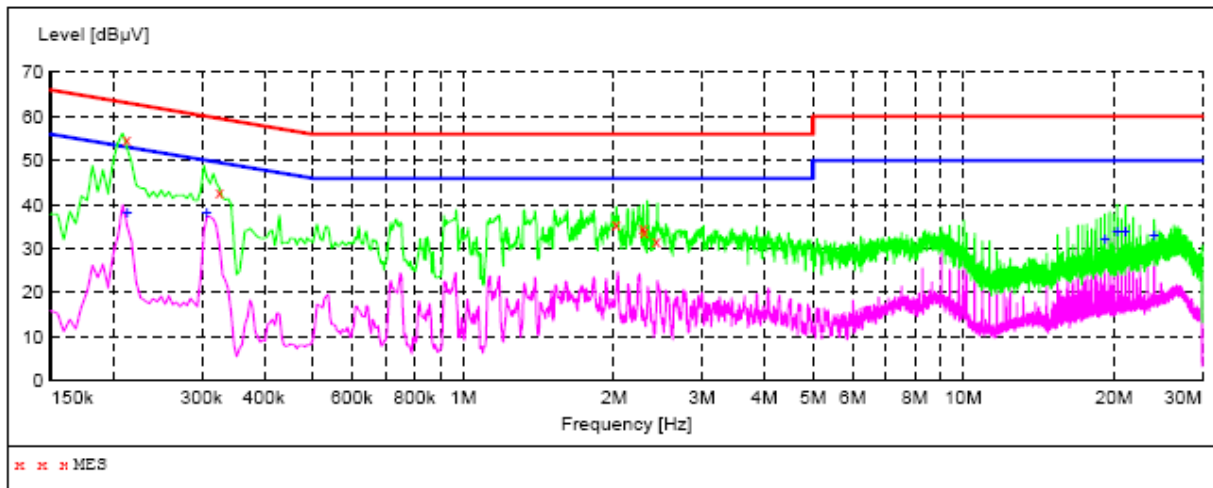

MEASUREMENT RESULT:

Frequency MHz	Level dBµV	Transd dB	Limit dBµV	Margin dB	Detector	Line	PE
0.213000	54.80	11.3	63	8.3	QP	N	GND
0.325500	42.90	10.9	60	16.7	QP	N	GND
2.022000	35.70	10.4	56	20.3	QP	N	GND
2.292000	34.90	10.4	56	21.1	QP	N	GND
2.296500	34.00	10.4	56	22.0	QP	N	GND
2.431500	31.70	10.4	56	24.3	QP	N	GND

MEASUREMENT RESULT:

Frequency MHz	Level dBµV	Transd dB	Limit dBµV	Margin dB	Detector	Line	PE
0.213000	38.00	11.3	53	15.1	AV	N	GND
0.307500	38.10	10.9	50	11.9	AV	N	GND
19.180500	32.20	10.7	50	17.8	AV	N	GND
20.310000	33.90	10.7	50	16.1	AV	N	GND
21.061500	33.80	10.7	50	16.2	AV	N	GND
24.063000	33.00	10.8	50	17.0	AV	N	GND

5. Test of Radiated Emission

5.1 Applicable Standard

Section 15.225 (a) The field strength of any emissions within the band 13.553-13.567 MHz shall not exceed 15,848 microvolts/meter at 30 meters.

Section 15.225 (b) Within the bands 13.410-13.553 MHz and 13.567-13.710 MHz, the field strength of any emissions shall not exceed 334 microvolts/meter at 30 meters.

Section 15.225 (c) Within the bands 13.110-13.410 MHz and 13.710-14.010 MHz the field strength of any emissions shall not exceed 106 microvolts/meter at 30 meters.

Section 15.225 (d) The field strength of any emissions appearing outside of the 13.110-14.010 MHz band shall not exceed the general radiated emission limits in § 15.209.

5.2 Limit of Radiated Disturbances

Except as provided elsewhere in this Subpart, the emissions from an intentional radiator shall not exceed the field strength levels specified in the following table:

Frequency (MHz)	Field strength @30m (uV/m)	Field strength @30m (dBuV/m)	Field strength @3m (dBuV/m)
Below 13.110	30	29.5	69.5
13.110 ~13.410	106	40.5	80.5
13.410~13.553	334	50.5	90.5
13.553~13.567	15,848	84	124
13.567~13.710	334	50.5	90.5
13.710~14.010	106	40.5	80.5
Above 14.010	30	29.5	69.5

Note:

(1) The tighter limit shall apply at the edge between two frequency bands.

(2) $\text{dBuV/m} = 20 \cdot \log(\text{uV/m})$

(3) Distance factor = 40dB / decade(15.31(f))

FCC Part15, Subpart C Section 15.209 limit of radiated emission for frequency below1000MHz. The emissions from an intentional radiator shall not exceed the field strength levels specified in the following table:

Frequency (MHz)	Distance (Meters)	Field Strengths Limits
0.009 -0.490	300	2400/F(KHz) ($\mu\text{V/m}$)
0.490 -1.705	30	24000/F(KHz) ($\mu\text{V/m}$)
1.705 -30	30	30 ($\mu\text{V/m}$)
30 -88	3	40.0 (dB $\mu\text{V/m}$)
88 -216	3	43.5 (dB $\mu\text{V/m}$)
216 -960	3	46.0 (dB $\mu\text{V/m}$)
Above 960	3	54.0 (dB $\mu\text{V/m}$)

Note:

(1) The tighter limit shall apply at the edge between two frequency bands.

(2) Distance refers to the distance in meters between the test instrument antenna and the closest point of any part of the E.U.T.

5.3 EUT Setup

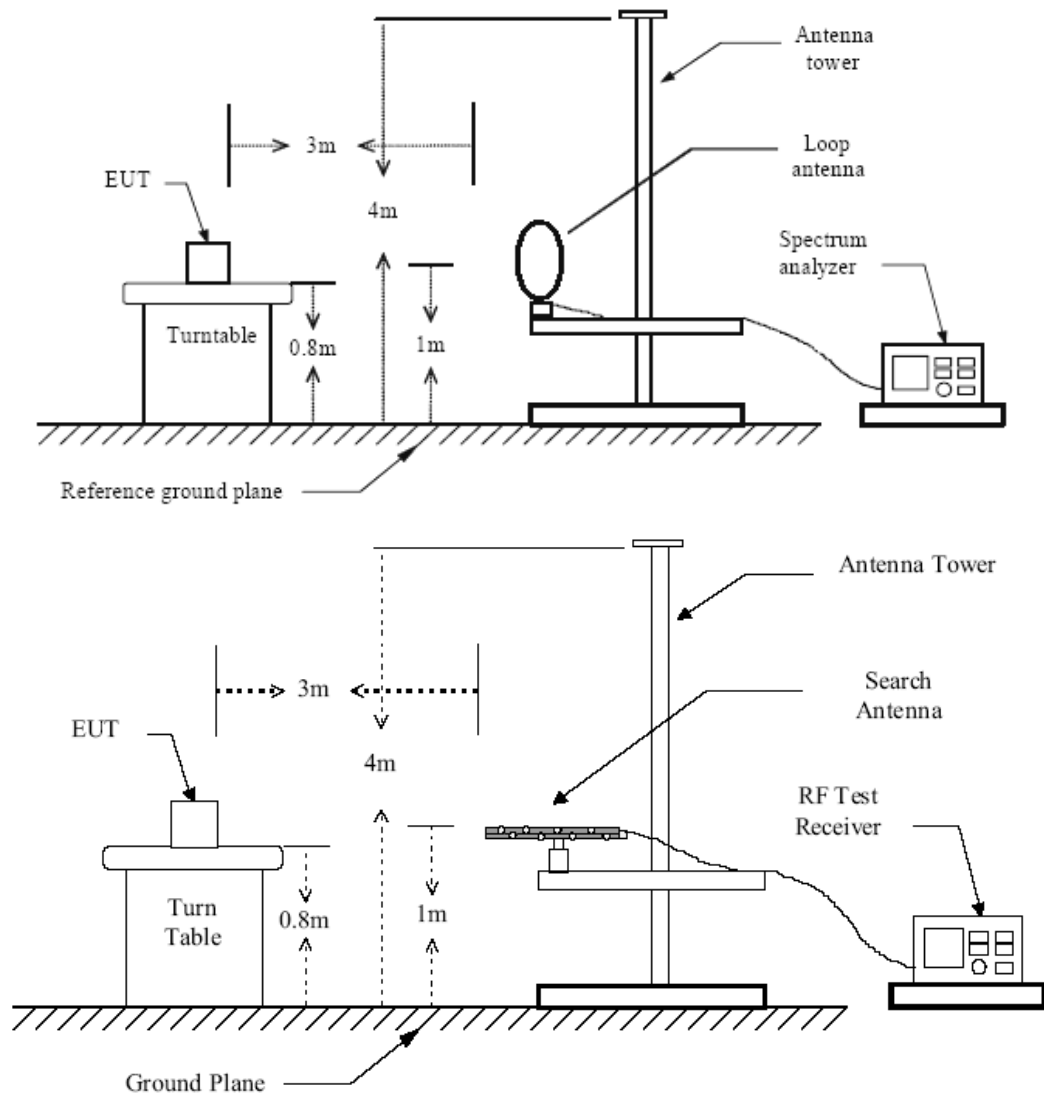

Figure 1 : Frequencies measured below 1 GHz configuration

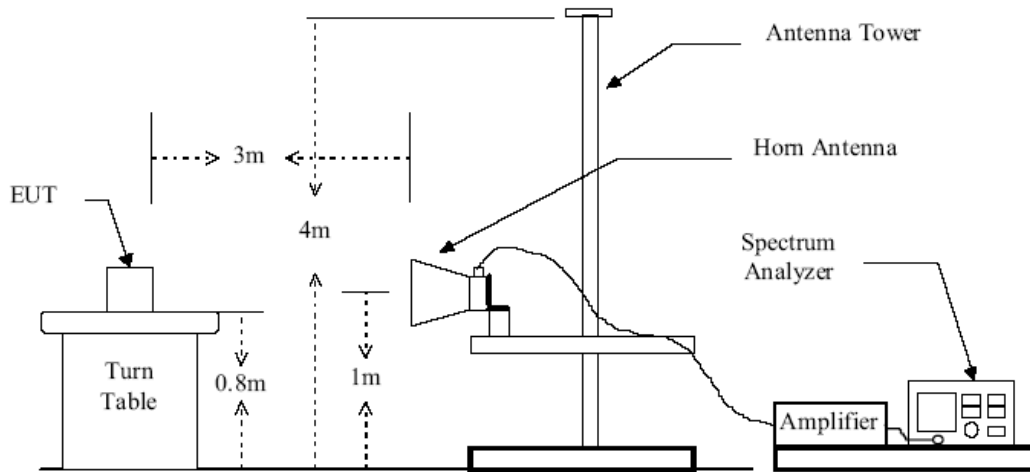

Figure 2 : Frequencies measured above 1 GHz configuration

5.4 Test Equipment List and Details

See section 2.5.

5.5 Test Procedure

1. Configure the EUT according to ANSI C63.4-2003
2. The EUT was placed on the top of the turntable 0.8 meter above ground.
3. Receiving antenna mounted on the top of a height-variable antenna tower was placed 3 meters far away from the turntable. When the frequency spectrum measured started from 9 kHz to 30 MHz, a loop antenna is used. When the frequency spectrum measured started from 30 MHz to 1000 MHz or above 1000 MHz, a broadband receiving antenna or the horn antenna are used.
4. Power on the EUT and all the supporting units.
5. The turntable was rotated by 360 degrees to determine the position of the highest radiation.
6. The height of the receiving antenna was varied between one meter and four meters above ground to find the maximum emission field strength of both horizontal and vertical polarization.
7. For each suspected emission, the antenna tower was scanned (from 1 M to 4 M) and then the turntable was rotated (from 0 degree to 360 degrees) to find the maximum reading.
8. Set the test-receiver system to Peak, CISPR quasi-peak or Average detect function with specified bandwidth according to different frequency spectrum measured under Maximum Hold Mode.

5.6 Test Result

Temperature (°C) : 22~23	EUT: RFID Time Attendance, Access Control, Data Collection Terminal
Humidity (%RH) : 50~54	M/N: B-web 96 00-Legic
Barometric Pressure (mbar) : 950~1000	Operation Condition: Tx mode

Indicated		Transfer factor dB	Table Angle Degree	Test Antenna		Convert Level dBuV/m	Limit dBuV/m at 3m	Margin dB
Frequency MHz	Ampl./ dBuA			Height Meter	Polar H/V			
13.56	33.0	18.75	125	1.5	V	84.50	124	-39.5
13.553	---	18.75	125	1.5	V	---	70	---
13.557	---	18.75	125	1.5	V	---	70	---

Remark: 1. Transd.=Antenna Factor+Cable Loss-Pre-amplifier
Margin = Level-Limit
Mark: P means Peak Value, Q means Quasi Peak Value, A means Average Value
2. Data of measurement within this frequency range shown " - " in the table above means the reading of emissions are attenuated more than 20dB below the permissible limits or the field strength is too small to be measured.
3. The test limit distance is 3m limit

Radiated Emission Test Data Below 30MHz:

Frequency (MHz)	Meter Reading (dB μ V)	Antenna Factor (dB/M)	Cable Loss (dB)	Emission Levels (dB μ V/M)	Limits (dB μ V/M)	Margin (dB)	Detector Mode PK/QP
5.87	22.56	8.23	1.03	29.76	67	-37.24	QP
14.78	21.38	9.07	1.19	29.26	49.5	-20.24	QP
21.56	21.59	9.25	1.08	29.76	49.5	-19.74	QP
24.69	21.45	8.43	1.66	28.22	49.5	-21.28	QP

Radiated Emission Test Data Below 1G:

EUT: RFID Time Attendance, Access Control, Data Collection Terminal
M/N: B-web 96 00-Legic
Operating Condition: Tx mode
Test Site: 3m CHAMBER
Operator: Chen
Test Specification: AC 120V/60Hz for POE Switch
Comment: Polarization: Horizontal

SWEEP TABLE: "test (30M-1G)"

Short Description:		Field Strength			
Start	Stop	Detector	Meas. Time	IF Bandw.	Transducer
Frequency	Frequency				
30.0 MHz	1.0 GHz	MaxPeak	Coupled	100 kHz	VULB9163 NEW

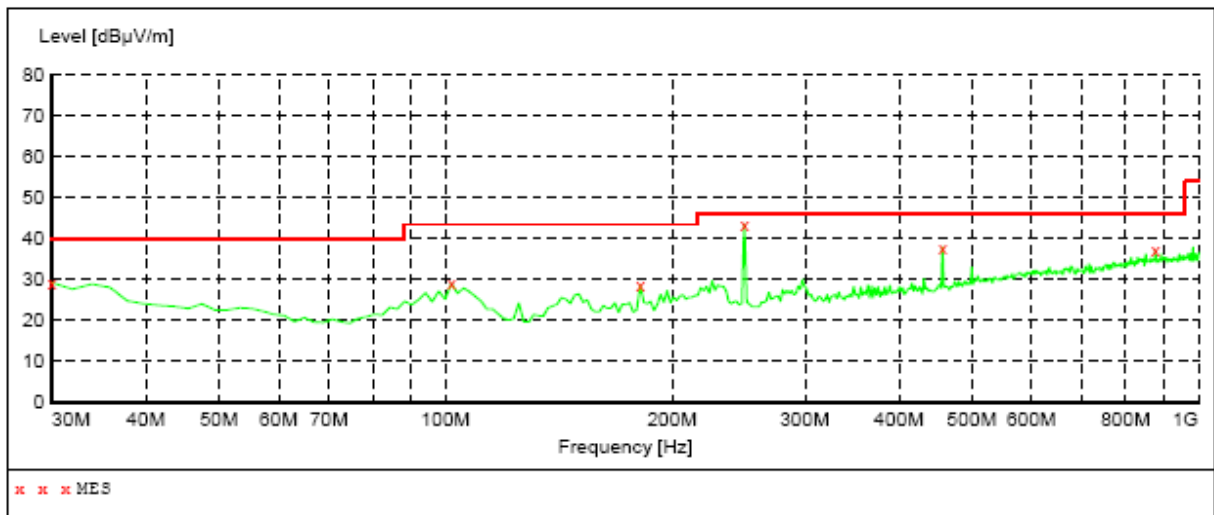

MEASUREMENT RESULT:

Frequency MHz	Level dBµV/m	Transd dB	Limit dBµV/m	Margin dB	Det.	Height cm	Azimuth deg	Polarization
30.000000	29.20	14.3	40.0	10.8	QP	300.0	0.00	HORIZONTAL
101.780000	29.10	17.3	43.5	14.4	QP	300.0	0.00	HORIZONTAL
181.320000	28.70	14.0	43.5	14.8	QP	300.0	0.00	HORIZONTAL
249.220000	43.60	17.2	46.0	2.4	QP	100.0	0.00	HORIZONTAL
456.800000	37.90	22.2	46.0	8.1	QP	100.0	0.00	HORIZONTAL
875.840000	37.10	28.9	46.0	8.9	QP	100.0	0.00	HORIZONTAL

Radiated Emission Test Data Below 1G:

EUT: RFID Time Attendance, Access Control, Data Collection Terminal
M/N: B-web 96 00-Legic
Operating Condition: Tx mode
Test Site: 3m CHAMBER
Operator: Chen
Test Specification: AC 120V/60Hz for POE Switch
Comment: Polarization: Vertical

SWEEP TABLE: "test (30M-1G)"

Short Description:		Field Strength			
Start	Stop	Detector	Meas. Time	IF Bandw.	Transducer
Frequency	Frequency				
30.0 MHz	1.0 GHz	MaxPeak	Coupled	100 kHz	VULB9163 NEW

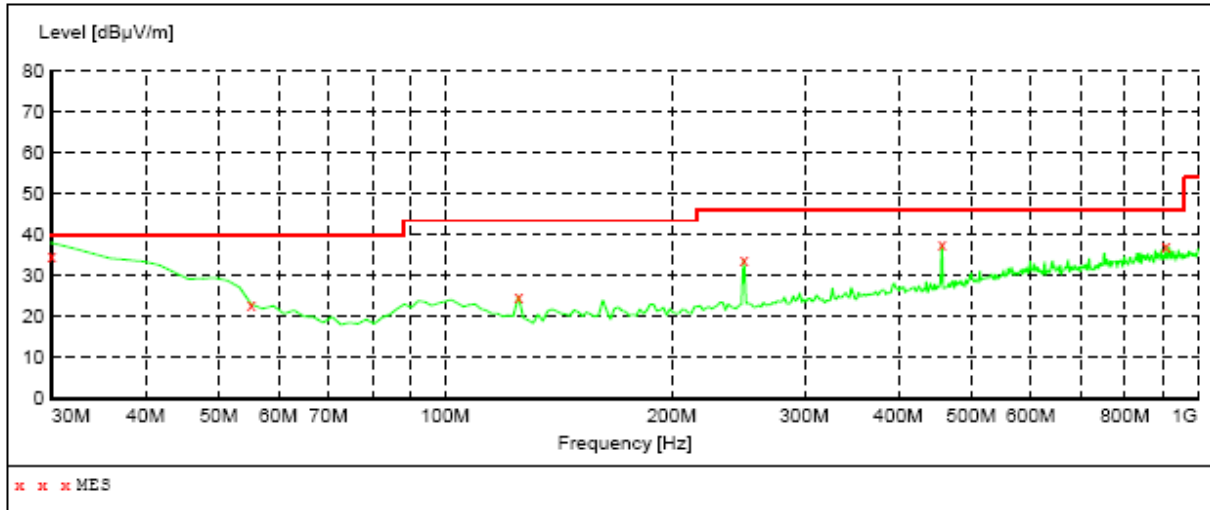

MEASUREMENT RESULT:

Frequency MHz	Level dBµV/m	Transd dB	Limit dBµV/m	Margin dB	Det.	Height cm	Azimuth deg	Polarization
30.000000	35.00	14.3	40.0	5.0	QP	100.0	0.00	VERTICAL
55.220000	23.10	15.6	40.0	16.9	QP	100.0	0.00	VERTICAL
125.060000	25.10	13.8	43.5	18.4	QP	100.0	0.00	VERTICAL
249.220000	34.00	17.2	46.0	12.0	QP	100.0	0.00	VERTICAL
456.800000	37.60	22.2	46.0	8.4	QP	100.0	0.00	VERTICAL
906.880000	37.40	29.2	46.0	8.6	QP	100.0	0.00	VERTICAL

6. Frequency Tolerance

6.1 Applicable Standard

Section 15.225(e): The frequency tolerance of the carrier signal shall be maintained within +/- 0.01% of the operating frequency over a temperature variation of -20 degrees to +50 degrees C at normal supply voltage, and for a variation in the primary supply voltage from 85% to 115% of the rated supply voltage at a temperature of 20 degrees C. For battery operated equipment, the equipment tests shall be performed using a new battery.

6.2 EUT Setup

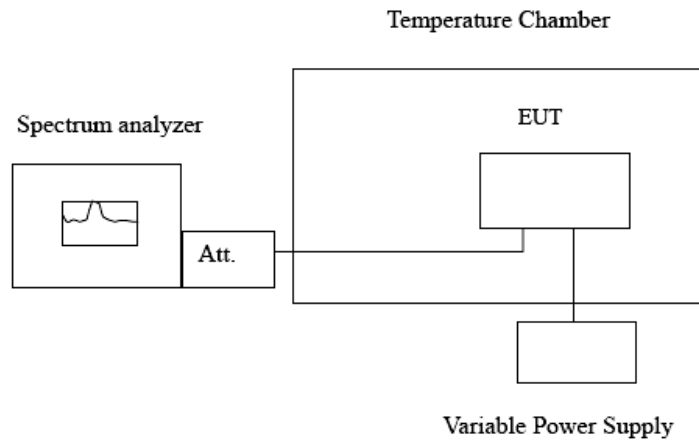

6.3 Test Equipment List and Details

See section 2.5.

6.4 Test Procedure

The frequency stability of the transmitter is measured by:

- (a) Temperature: The temperature is varied from -20 to +50°C using an environmental chamber.
- (b) Primary Supply Voltage: The primary supply voltage is varied from 85% to 115% of the voltage normally input to the device or at the power supply terminals if cables are not normally supplied.

The frequency tolerance of the carrier shall be maintained within $\pm 0.01\%$ of the operating frequency.

6.5 Test Result

Temperature (°C) : 22~23	EUT: RFID Time Attendance, Access Control, Data Collection Terminal
Humidity (%RH) : 50~54	M/N: B-web 96 00-Legic
Barometric Pressure (mbar) : 950~1000	Operation Condition: Tx Mode

Voltage (%)	Power (VDC)	Temperature (°C)	Frequency (MHz)	Deviation (%)
100	48	+20°C (Ref)	13.559573	-0.0031490
100	48	-20	13.559689	-0.0022935
100	48	-10	13.559674	-0.0024041
100	48	0	13.559653	-0.0025590
100	48	10	13.559622	-0.0027876
100	48	25	13.559585	-0.0030605
100	48	30	13.559558	-0.0032596
100	48	40	13.559547	-0.0033407
100	48	50	13.559552	-0.0033038
85	40.8	20	13.559576	-0.0031268
115	55.2	20	13.559594	-0.0029941

7. ANTENNA REQUIREMENT

7.1 Standard Applicable

Section 15.203:

An intentional radiator shall be designed to ensure that no antenna other than that furnished by the responsible party shall be used with the device. The use of a permanently attached antenna or of an antenna that uses a unique coupling to the intentional radiator shall be considered sufficient to comply with the provisions of this Section. The manufacturer may design the unit so that a broken antenna can be replaced by the user, but the use of a standard antenna jack or electrical connector is prohibited.

7.2 Antenna Connected Construction

The antenna is designed with permanent attachment and no consideration of replacement. The antenna used in this product is complied with Standard. The maximum Gain of the antenna lower than 6.0dBi and have the definite antenna Specification.