

Test Report of FCC CFR 47 Part 15 Subpart C

On Behalf of

Kaba GmbH

FCC ID: NVIB-WEB9600
Product Description: RFID Time Attendance/ Access Control/ Data Collection Terminal
Model No.: B-web 96 00
Supplementary Model: N/A
Brand Name: N/A

Prepared for: Kaba GmbH
Albertstraße 3 Villingen-Schwenningen 78056 Germany

Prepared by: Bontek Compliance Testing Laboratory Ltd
1/F, Block East H-3, OCT Eastern Ind. Zone, Qiaocheng East Road, Nanshan, Shenzhen, China
Tel: 86-755-86337020
Fax: 86-755-86337028

Report No.: BCT12IR-1733E-3
Issue Date: February 21, 2013
Test Date: January 1~ February 16, 2013

Tested by:

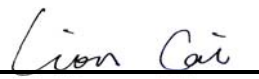
Lion Cai

Reviewed by:

Kendy Wang

Approved by:



Tony Wu

TABLE OF CONTENTS

1. GENERAL INFORMATION..... 3

1.1 PRODUCT DESCRIPTION FOR EQUIPMENT UNDER TEST (EUT)..... 3

1.2 TEST STANDARDS 3

1.3 TEST FACILITY 3

2. SYSTEM TEST CONFIGURATION 5

2.1 EUT CONFIGURATION 5

2.2 EUT EXERCISE 5

2.3 GENERAL TEST PROCEDURES 5

2.4 MEASUREMENT UNCERTAINTY 5

2.5 TEST EQUIPMENT LIST AND DETAILS 6

3. SUMMARY OF TEST RESULTS 7

4. TEST OF AC POWER LINE CONDUCTED EMISSION 8

4.1 APPLICABLE STANDARD..... 8

4.2 TEST SETUP DIAGRAM 8

4.3 TEST RESULT 8

5. TEST OF RADIATED EMISSION 11

5.1 APPLICABLE STANDARD..... 11

5.2 LIMIT OF RADIATED DISTURBANCES 11

5.3 EUT SETUP 11

5.4 TEST EQUIPMENT LIST AND DETAILS 12

5.5 TEST PROCEDURE 12

5.6 TEST RESULT 12

1. GENERAL INFORMATION

1.1 Product Description for Equipment Under Test (EUT)

Client Information

Applicant:	Kaba GmbH
Address of Applicant:	Albertstraße 3 Villingen-Schwenningen 78056 Germany
Manufacturer:	DongGuan ZKSoftware Electronic Technology Co.,Ltd
Address of Manufacturer:	No.26,Pingshan 188 Industry zone,Tangxia Town,Dongguan City,Guangdong Province,China 523728

General Description of E.U.T

Items	Description
EUT Description:	RFID Time Attendance/ Access Control/ Data Collection Terminal
Model No.:	B-web 96 00
Supplementary Model:	N/A
Trade Name:	N/A
Transmit Frequency:	125kHz
Number of Channels:	1
Duty cycle:	100%
Antenna Type:	Built-in Antenna
Power Supply:	Input: DC 12V 3A
Adapter Information:	Model: KSAFH1200300T1M3 INPUT:100-240V~50/60Hz 1.2A OUTPUT:12V 3A

Remark: * The test data gathered are from the production sample provided by the manufacturer.

1.2 Test Standards

The tests were performed in order to determine compliance with FCC Part 15, Subpart C, and section 15.207, 15.209 rules. Test was carried out according to the above mentioned FCC rules.

1.3 Test Facility

All measurement required was performed at laboratory of Bontek Compliance Testing Laboratory Ltd at 1/F, Block East H-3, OCT Eastern Ind. Zone, Qiaocheng East Road, Nanshan, Shenzhen, China.

The test facility is recognized, certified, or accredited by the following organizations:

FCC – Registration No.: 338263

BONTEK COMPLIANCE TESTING LABORATORY LTD. EMC Laboratory has been registered and fully described in a report filed with the (FCC) Federal Communications Commission. The acceptance letter from the FCC is maintained in our files. Registration 338263, March 03, 2011.

IC Registration No.: 7631A

The 3m alternate test site of BONTEK COMPLIANCE TESTING LABORATORY LTD. EMC Laboratory has been registered by Certification and Engineer Bureau of Industry Canada for the performance of with Registration NO.: 7631A on January 25, 2011.

CNAS - Registration No.: L3923

BONTEK COMPLIANCE TESTING LABORATORY LTD. to ISO/IEC 17025:25 General Requirements for the Competence of Testing and Calibration Laboratories(CNAS-CL01 Accreditation Criteria for the Competence of Testing and Calibration Laboratories) for the competence in the field of testing. The acceptance letter from the CNAS is maintained in our files: Registration: L3923, March 22, 2012.

TUV - Registration No.: UA 50203122-0001

BONTEK COMPLIANCE TESTING LABORATORY LTD. An assessment of the laboratory was conducted according to the "Procedures and Conditions for EMC Test Laboratories" with reference to EN ISO/IEC 17025 by a TUV Rheinland auditor. Audit Report NO. 17010783-002.

2. SYSTEM TEST CONFIGURATION

2.1 EUT Configuration

The EUT configuration for testing is installed on RF field strength measurement to meet the Commissions requirement and operating in a manner that intends to maximize its emission characteristics in a continuous normal application.

2.2 EUT Exercise

The calibrated antennas used to sample the radiated field strength are mounted on a non-conductive, motorized antenna mast 3 or 10 meters from the leading edge of the turntable.

Support equipments or special accessories in test configuration:

AUX Description:	Manufacturer	Model No.	Certificate	CABLE
Host Computer	Dell	78MD82X	CE, FCC	1.5m Unshielded Power Cord
Monitor	Dell	E178Pc	CE, FCC	1.5m Unshielded Power Cord 1.8m shielded data Cable with core
Keyboard	Dell	L100	CE, FCC	1.8m shielded data Cable with core
LCD Colour TV	SHARP	LCD-32Z330A	CE, FCC	1.2m Unshielded Power Cord 1.5m shielded data Cable with core

2.3 General Test Procedures

Conducted Emissions: The EUT is placed on the turntable, which is 0.8 m above ground plane. According to the requirements in Section 7.1 of ANSI C63.4-2003 Conducted emissions from the EUT measured in the frequency range between 0.15 MHz and 30MHz using CISPR Quasi-Peak detector mode.

Radiated Emissions: The EUT is a placed on as turntable, which is 0.8 m above ground plane. The turntable shall rotate 360 degrees to determine the position of maximum emission level. EUT is set 3m away from the receiving antenna, which varied from 1m to 4m to find out the highest emission. And also, each emission was to be maximized by changing the polarization of receiving antenna both horizontal and vertical. In order to find out the maximum emissions, exploratory radiated emission measurements were made according to the requirements in Section 13.1.4.1 of ANSI C63.4-2003.

2.4 Measurement Uncertainty

Where relevant, the following measurement uncertainty levels have been estimated for tests performed on the apparatus:

Parameter	Uncertainty
Power Line Conducted Emission	+/- 2.3 dB
Radiated Emission	+/- 3.4 dB

Uncertainty figures are valid to a confidence level of 95%.

2.5 Test Equipment List and Details

Test equipments list of Shenzhen Bontek Compliance Testing Laboratory Co., Ltd.

No.	Equipment	Manufacturer	Model No.	S/N	Calibration date	Calibration due date
1	EMI Test Receiver	R&S	ESCI	100687	2012-4-6	2013-4-5
2	EMI Test Receiver	R&S	ESPI	100097	2012-7-25	2013-7-24
3	Amplifier	HP	8447D	1937A02492	2012-4-6	2013-4-5
4	Single Power Conductor Module	FCC	FCC-LISN-5-50-1-01-CISPR25	07101	2012-4-6	2013-4-5
5	Single Power Conductor Module	FCC	FCC-LISN-5-50-1-01-CISPR25	07102	2012-4-6	2013-4-5
6	Positioning Controller	C&C	CC-C-1F	MF7802113	N/A	N/A
7	Signal generator	Rhode & Schwarz	SMIQ 03HD + option SM-B1, SMIQB11, SMIQB12, SMIQB14, SMIQB17, SMIQB20	1125.5555.46	2012-4-6	2013-4-5
8	GSM system simulator	Rhode & Schwarz	CMU200 + option K20, K21, K22, K23, K24, K27, K28, K29, K42, K65, B12, B41, B52, B66, B56	1100.0008.34	2012-4-6	2013-4-5
9	GSM system simulator	Agilent	8960 Series 10 E1985A + GSM_AMPS	B.01.76 GB42450443	2012-4-6	2013-4-5
10	Spectrum Analyzer	Agilent	E4404B	US41192833	2012-4-6	2013-4-5
11	6dB Attenuator	Atten	Attenuator	DC-4GHz	2012-4-6	2013-4-5
12	Digital Multimeter	Fluke	15B	91280239	2012-4-6	2013-4-5
13	TRILOG Broadband Test-Antenna	SCHWARZBECK	VULB9163	9163-324	2012-4-10	2013-4-9
14	Horn Antenna	SCHWARZBECK	BBHA9120A	0499	2012-11-28	2013-11-27
15	Active Loop Antenna	DAZE	ZN30900A	1200	2012-4-6	2013-4-6
16	9kHz-2.4GHz signal generator 2024	MARCONI	10S/6625-99-457-8730	112260/042	2012-4-6	2013-4-5
17	10dB attenuator	ELECTRO-METRICS	EM-7600	836	2012-4-6	2013-4-5
18	Spectrum Analyzer	R&S	FSP	100397	2012-11-2	2013-11-1
19	Broadband preamplifier	SCHWARZBECK	BBV9718	9718-182	2012-4-6	2013-4-5
20	Temperature & Humidity Chamber	TOPSTAT	TOS-831A	3438A05208	2012-4-6	2013-4-5

3. SUMMARY OF TEST RESULTS

FCC Rules	Description of Test	Result
FCC §15.207	AC Power Line Conducted Emission	Pass
FCC §15.209	Radiated Emission (9kHz ~ 30MHz)	Pass
FCC §15.209	Radiated Emission (30MHz ~ 1GHz)	Pass

4. TEST OF AC POWER LINE CONDUCTED EMISSION

4.1 Applicable Standard

Refer to FCC §15.207.

For a Low-power Radio-frequency Device is designed to be connected to the AC power line, the radio frequency voltage that is conducted back onto the AC power line on any frequency or frequencies within the band 150 kHz to 30 MHz shall not exceed below limits table.

Frequency Range (MHz)	Limits (dBuV)	
	Quasi-Peak	Average
0.150~0.500	66~56	56~46
0.500~5.000	56	46
5.000~30.00	60	50

4.2 Test Setup Diagram

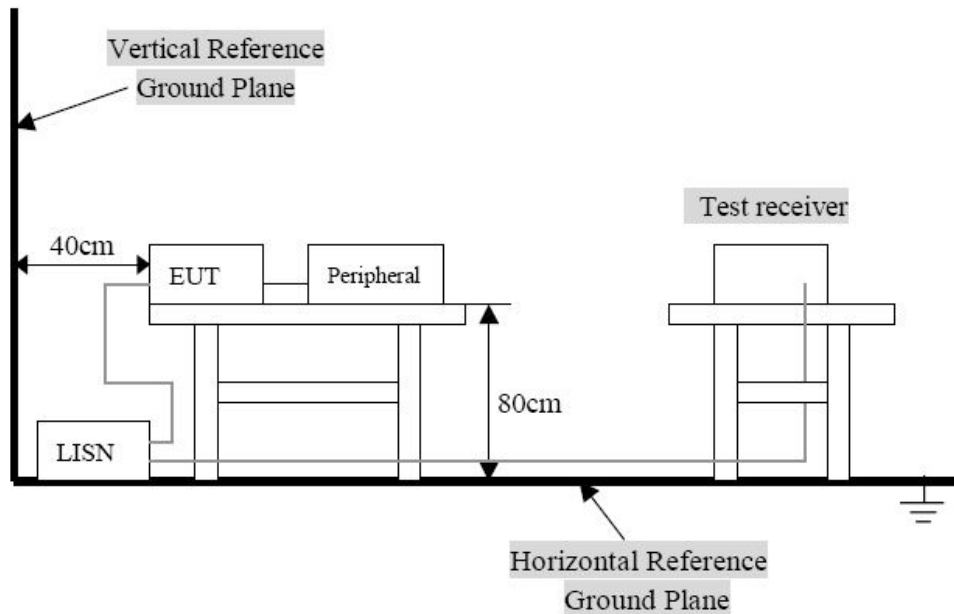

Remark: The EUT was connected to a 120VAC/ 60Hz power source.

4.3 Test Result

Temperature (°C) : 23~25	EUT: RFID Time Attendance/ Access Control/ Data Collection Terminal
Humidity (%RH) : 45~58	M/N: B-web 96 00
Barometric Pressure (mbar) : 950~1000	Operation Condition: Power On

Conducted Emission Test Data

EUT: RFID Time Attendance/ Access Control/ Data Collection Terminal
 Operating Condition: Power On
 Test Site: Shielded Room
 Operator: Andy
 Test Specification: AC/DC adapter (AC 120V/60Hz)
 Comment: Live Line

SCAN TABLE: "Voltage (9K-30M) FIN"
 Short Description: 150K-30M Voltage

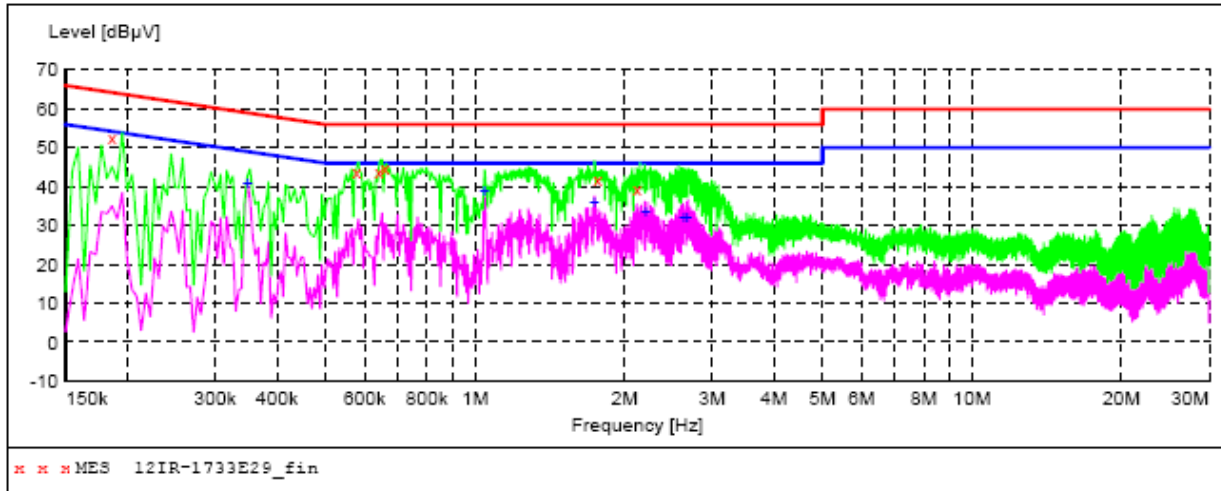

MEASUREMENT RESULT: "12IR-1733E29_fin"

1/12/2013

Frequency MHz	Level dBµV	Transd dB	Limit dBµV	Margin dB	Detector	Line	PE
0.186000	52.80	11.0	64	11.4	QP	L1	GND
0.577500	43.70	10.2	56	12.3	QP	L1	GND
0.640500	44.00	10.2	56	12.0	QP	L1	GND
0.658500	44.70	10.2	56	11.3	QP	L1	GND
1.765500	41.80	10.2	56	14.2	QP	L1	GND
2.121000	39.30	10.2	56	16.7	QP	L1	GND

MEASUREMENT RESULT: "12IR-1733E29_fin2"

1/12/2013

Frequency MHz	Level dBµV	Transd dB	Limit dBµV	Margin dB	Detector	Line	PE
0.348000	40.90	10.5	49	8.1	AV	L1	GND
1.045500	38.90	10.3	46	7.1	AV	L1	GND
1.738500	36.10	10.2	46	9.9	AV	L1	GND
2.206500	33.50	10.2	46	12.5	AV	L1	GND
2.625000	31.90	10.2	46	14.1	AV	L1	GND
2.670000	32.10	10.2	46	13.9	AV	L1	GND

Conducted Emission Test Data

EUT: RFID Time Attendance/ Access Control/ Data Collection Terminal
 Operating Condition: Power On
 Test Site: Shielded Room
 Operator: Andy
 Test Specification: AC/DC adapter (AC 120V/60Hz)
 Comment: Neutral Line

SCAN TABLE: "Voltage (9K-30M) FIN"
 Short Description: 150K-30M Voltage

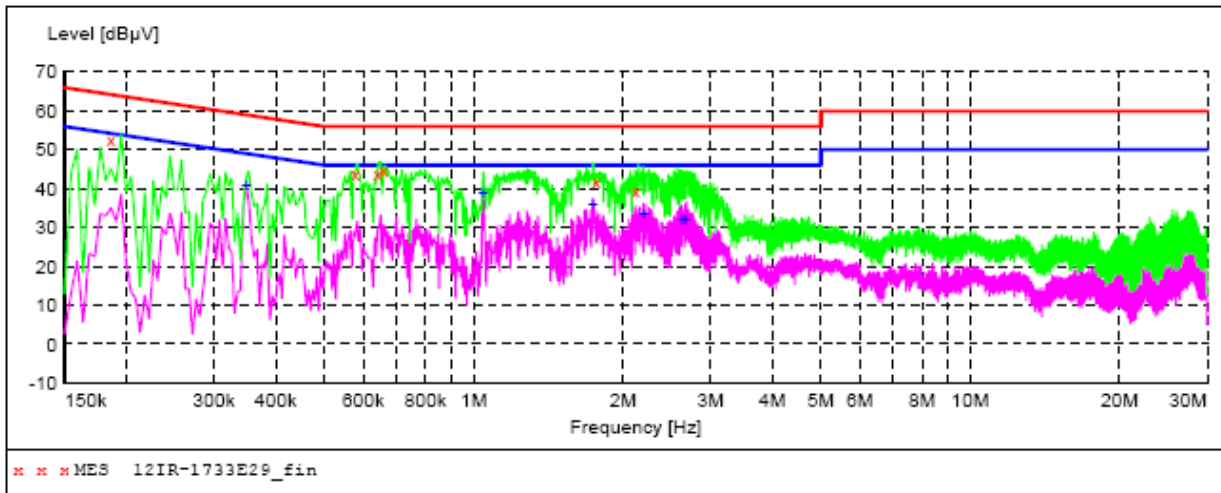

MEASUREMENT RESULT: "12IR-1733E29_fin"

1/12/2013

Frequency MHz	Level dBµV	Transd dB	Limit dBµV	Margin dB	Detector	Line	PE
0.186000	52.80	11.0	64	11.4	QP	L1	GND
0.577500	43.70	10.2	56	12.3	QP	L1	GND
0.640500	44.00	10.2	56	12.0	QP	L1	GND
0.658500	44.70	10.2	56	11.3	QP	L1	GND
1.765500	41.80	10.2	56	14.2	QP	L1	GND
2.121000	39.30	10.2	56	16.7	QP	L1	GND

MEASUREMENT RESULT: "12IR-1733E29_fin2"

1/12/2013

Frequency MHz	Level dBµV	Transd dB	Limit dBµV	Margin dB	Detector	Line	PE
0.348000	40.90	10.5	49	8.1	AV	L1	GND
1.045500	38.90	10.3	46	7.1	AV	L1	GND
1.738500	36.10	10.2	46	9.9	AV	L1	GND
2.206500	33.50	10.2	46	12.5	AV	L1	GND
2.625000	31.90	10.2	46	14.1	AV	L1	GND
2.670000	32.10	10.2	46	13.9	AV	L1	GND

5. Test of Radiated Emission

5.1 Applicable Standard

Refer to FCC §15.209.

5.2 Limit of Radiated Disturbances

FCC Part15, Subpart C Section 15.209 limit of radiated emission for frequency below1000MHz. The emissions from an intentional radiator shall not exceed the field strength levels specified in the following table:

Frequency (MHz)	Distance (Meters)	Field Strengths Limits (dB μ V/m)
0.009 -0.490	300	2400/F(KHz)
0.490 -1.705	30	24000/F(KHz)
1.705 -30	30	30
30 -88	3	40.0
88 -216	3	43.5
216 -960	3	46.0
Above 960	3	54.0

Note:

(1) The tighter limit shall apply at the edge between two frequency bands.

(2) Distance refers to the distance in meters between the test instrument antenna and the closest point of any part of the E.U.T.

5.3 EUT Setup

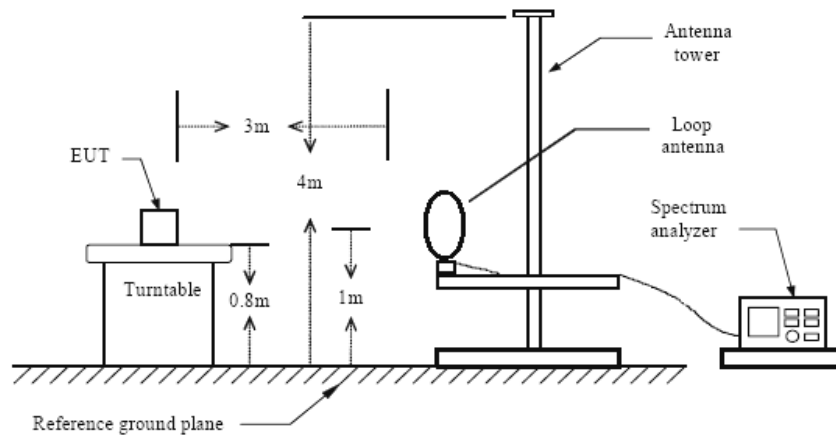

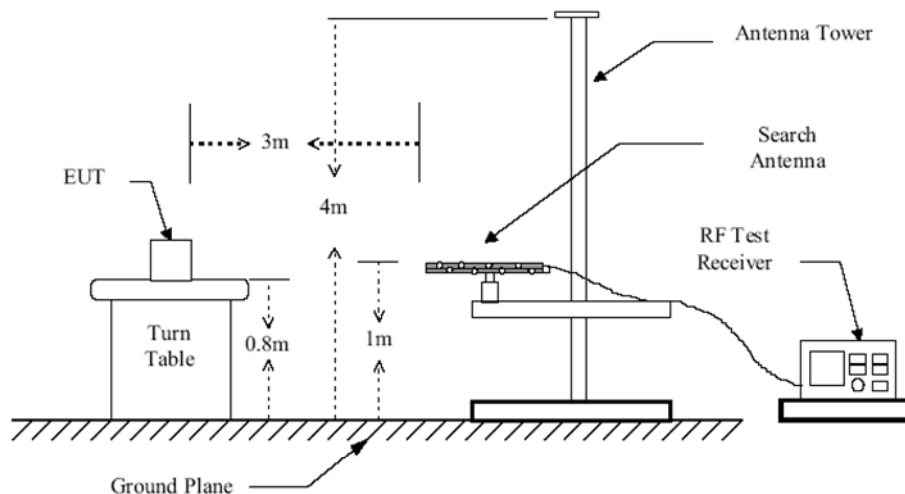

Figure 1 : Frequencies measured below 1 GHz configuration

5.4 Test Equipment List and Details

See section 2.5.

5.5 Test Procedure

1. Configure the EUT according to ANSI C63.4-2003
2. The EUT was placed on the top of the turntable 0.8 meter above ground.
3. Receiving antenna mounted on the top of a height-variable antenna tower was placed 3 meters far away from the turntable. When the frequency spectrum measured started from 9 kHz to 30 MHz, a loop antenna is used. When the frequency spectrum measured started from 30 MHz to 1000 MHz or above 1000 MHz, a broadband receiving antenna or the horn antenna are used.
4. Power on the EUT and all the supporting units.
5. The turntable was rotated by 360 degrees to determine the position of the highest radiation.
6. The height of the receiving antenna was varied between one meter and four meters above ground to find the maximum emission field strength of both horizontal and vertical polarization.
7. For each suspected emission, the antenna tower was scanned (from 1 M to 4 M) and then the turntable was rotated (from 0 degree to 360 degrees) to find the maximum reading.
8. Set the test-receiver system to Peak, CISPR quasi-peak or Average detect function with specified bandwidth according to different frequency spectrum measured under Maximum Hold Mode.

5.6 Test Result

Temperature (°C) : 22~23	EUT: RFID Time Attendance/ Access Control/ Data Collection Terminal
Humidity (%RH) : 50~54	M/N: B-web 96 00
Barometric Pressure (mbar) : 950~1000	Operation Condition: Power On

NOTE:

In this testing, the EUT was respectively tested in three different orientations. That is:

- (1) EUT was lie vertically, and then its Antenna oriented upward
- (2) EUT was lie vertically, and then its Antenna oriented downward
- (3) EUT was lie flatwise, and then its Antenna oriented to the receiving antenna

The worst test data see following pages When the EUT was lie vertically, and then its Antenna oriented upward, the worst test data was got as following table.

WORST-CASE RADIATED EMISSION BELOW 30 MHz

Frequency	Meter Reading	Polar	Antenna Factor	Cable Loss	Emission Levels	Limits at 3m	Margin	Detector Mode
(MHz)	(dB μ V)	H/V	(dB/m)	(dB)	(dB μ V/m)	(dB μ V/m)	(dB)	QP /AV
0.125	75.46	V	18.36	1.23	10.84	69.2	-58.36	AV
0.47	20.45	V	7.87	1.03	29.35	67	-37.65	QP
17.25	20.13	V	8.92	1.19	30.24	49.5	-19.26	QP
19.63	21.08	V	8.66	1.08	30.82	49.5	-18.68	QP
25.37	23.66	V	7.49	1.66	32.81	49.5	-16.69	QP

Remark:

- 1. Data of measurement within this frequency range shown “-” in the table above means the reading of emissions are attenuated more than 20dB below the permissible limits or the field strength is too small to be measured.
- 2. The test limit distance is 3m limit.
- 3. PK means Peak Value, QP means Quasi Peak Value, AV means Average Value.

Radiated Emission Test Data 30MHz~1000MHz:

EUT: RFID Time Attendance/ Access Control/ Data Collection Terminal
M/N: B-web 96 00
Operating Condition: Power On
Test Site: 3m CHAMBER
Operator: Chen
Test Specification: AC 120V/60Hz for adapter
Comment: Polarization: Horizontal

SWEEP TABLE: "test (30M-1G)"

Short Description:		Field Strength				Transducer
Start Frequency	Stop Frequency	Detector	Meas. Time	IF Bandw.		
30.0 MHz	1.0 GHz	MaxPeak	Coupled	100 kHz	VULB9163 NEW	

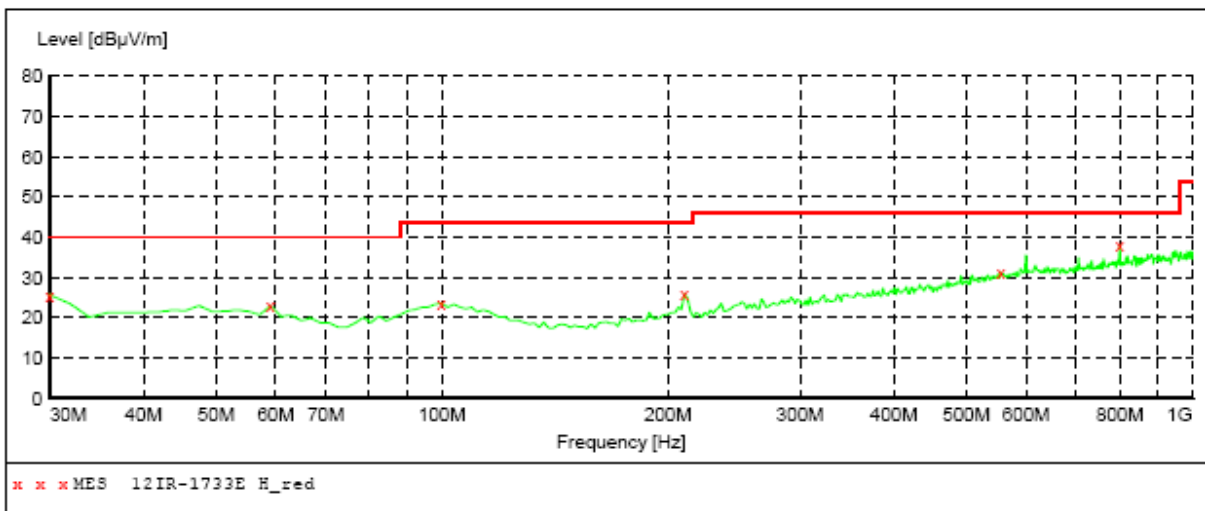

MEASUREMENT RESULT: "12IR-1733E H_red"

1/14/2013

Frequency MHz	Level dBµV/m	Transd dB	Limit dBµV/m	Margin dB	Det.	Height cm	Azimuth deg	Polarization
30.000000	25.60	14.3	40.0	14.4	QP	100.0	0.00	HORIZONTAL
59.100000	22.90	14.6	40.0	17.1	QP	300.0	0.00	HORIZONTAL
99.840000	23.60	17.5	43.5	19.9	QP	100.0	0.00	HORIZONTAL
210.420000	25.90	15.1	43.5	17.6	QP	300.0	0.00	HORIZONTAL
555.740000	31.30	25.1	46.0	14.7	QP	100.0	0.00	HORIZONTAL
800.180000	37.80	28.0	46.0	8.2	QP	100.0	0.00	HORIZONTAL

Radiated Emission Test Data 30MHz~1000MHz:

EUT: RFID Time Attendance/ Access Control/ Data Collection Terminal
M/N: B-web 96 00
Operating Condition: Power On
Test Site: 3m CHAMBER
Operator: Chen
Test Specification: AC 120V/60Hz for adapter
Comment: Polarization: Vertical

SWEEP TABLE: "test (30M-1G)"

Short Description:		Field Strength			Transducer
Start Frequency	Stop Frequency	Detector	Meas. Time	IF Bandw.	
30.0 MHz	1.0 GHz	MaxPeak	Coupled	100 kHz	VULB9163 NEW

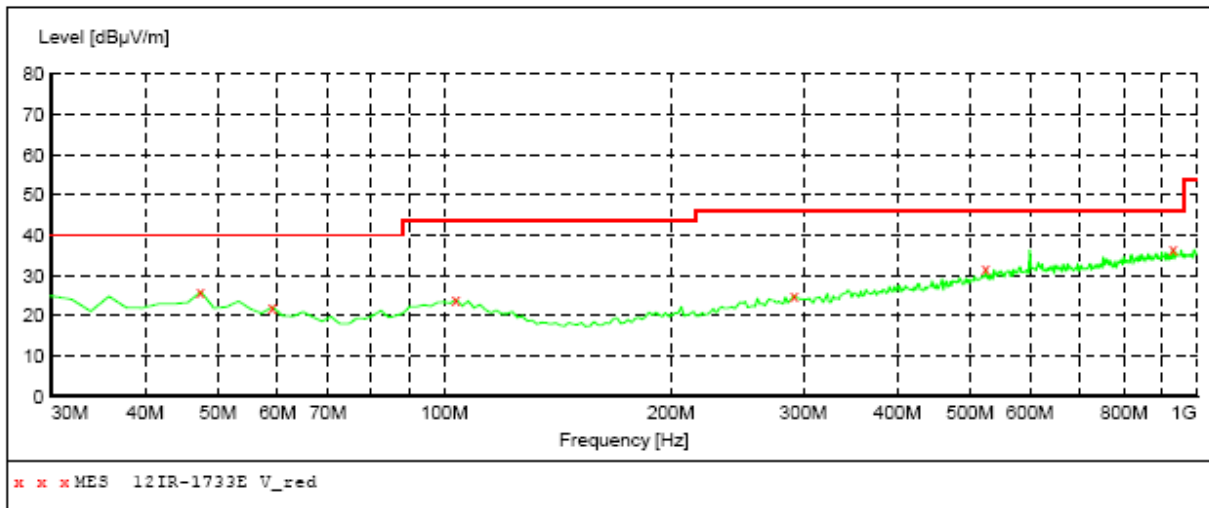

MEASUREMENT RESULT: "12IR-1733E V_red"

1/14/2013

Frequency MHz	Level dBµV/m	Transd dB	Limit dBµV/m	Margin dB	Det.	Height cm	Azimuth deg	Polarization
47.460000	25.90	15.8	40.0	14.1	QP	100.0	0.00	VERTICAL
59.100000	22.20	14.6	40.0	17.8	QP	100.0	0.00	VERTICAL
103.720000	24.00	17.1	43.5	19.5	QP	100.0	0.00	VERTICAL
291.900000	25.00	18.5	46.0	21.0	QP	100.0	0.00	VERTICAL
524.700000	31.50	24.4	46.0	14.5	QP	100.0	0.00	VERTICAL
930.160000	36.40	29.4	46.0	9.6	QP	100.0	0.00	VERTICAL