

About this quick guide

Validity

This quick guide describes the product

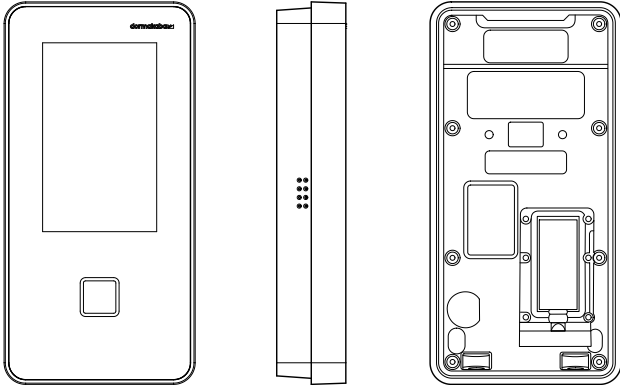

Product designation:	Terminal 96 00
Product ID:	9600-K6
Item number:	04079601
Date of manufacture:	From September 2019

Target group

This quick guide should only be used by skilled persons trained by the manufacturer.

Additional documentation

The content of this quick guide is an excerpt from the technical manual and is limited to essential information about the product and how to install it.

Details on functions, commissioning and parameter setting of the product can be found in the following documentation:

- Terminal 96 00 - Technical Manual
- B-Client HR20/HR15/AC15 - reference manual
- Service interface - reference manual

Additional documentation is available on the Internet at the dormakaba website. The technical manuals are located in a protected area. They can be accessed via the user account of trained professionals. However, you can also create a temporary account.

<https://www.dormakaba.com/extranet-emea-en>

Safety instructions

Designated use

The product is only intended for use as described in chapter "Product description". Any use beyond that is considered contrary to its designated use. The manufacturer cannot be held liable for damage resulting from such use.

Staff qualification

The actions described in this quick start guide must only be carried out by skilled persons in accordance with EN 62368-1.

Skilled person is the designation for people who have the appropriate technical training and experience in setting up the equipment. Skilled persons are expected to use their training and experience to identify any risks to themselves and others that may arise while carrying out these activities, and to minimise these risks as far as possible. It is the skilled person's responsibility to ensure that the conditions stated by the manufacturer and the applicable regulations and standards are complied with when carrying out these actions.

Assembly and installation

The product should only be installed in locations which fulfil the environmental and technical conditions specified by the manufacturer.

The manufacturer is not liable for damage arising due to improper handling or incorrect installation.

Environmental protection

It is prohibited to dispose of the device in your domestic waste.

Used devices contain valuable materials that should be recycled. Properly dispose of used devices.

Product description

The terminal 96 00 can be used for time and attendance and as CardLink update terminal.

Depending on the focus of application, B-Client AC15, B-Client HR15 or B-Client HR20 terminal software is available. The operating system used of the terminal 96 00 is 'Android'.

To display information, the terminal has a graphic 4" TFT colour display with a resolution of 480 x 800 pixels. A capacitive input field extends over the display surface and is operated by touching the glass front.

The person-related data is recorded by a contactless RFID reader. In addition, there is the possibility of booking with a smartphone.

The communication with the superior system takes place via Ethernet. Alternatively and optionally, communication can also take place via radio network or WLAN.

The terminal is supplied with Power over Ethernet (PoE).

Technical data

System

Operating system

- Android version 5.0.2 (Lollipop)

CPU

- Freescale i.MX6DualLite processor

Memory

- 2 GByte DDR3 RAM
- 8 GByte eMMC Flash

Parameters and data records are retained without supply voltage.

Real-time clock

The device has an integrated real-time clock. The function of the RTC is ensured for about 2 months without power supply of the device.

Display

- TFT LCD display module
- Size: 4.0"
- Resolution: 480 x 800 pixels (16:9 diagonal)
- Colour depth: 24-bit (true colour)
- Luminance: 350 cd/m²
- Backlit with 8 LEDs

Touch screen

- 4" PCAP touch screen over the complete display

Audio

- Integrated loudspeaker (1 W)

Interfaces/Communication

Ethernet interface

- IEEE802.3 compatible 10BASE-T/100BASE-TX /1000BASE-T
Auto sensing, Auto MDIX

WLAN (optional)

- According to IEEE802.11 a/b/g/n (2.4 GHz + 5 GHz)
- Encryption: WPA2-PSK

Mobile radio (option)

- UMTS 900/2100 MHz (dual band)
- GSM 850/900/1800/1900 MHz (dual band)

Power supply**PoE (Power over Ethernet)**

Power supply of the terminal via the 8-wire Ethernet cable (max. 100 m)

- According to IEEE802.3at
- PD type 1
- Performance class 0 (0.44-12.95 W)
- Supported feed processes: Spare pair feed and phantom feed

Reader

Depending on the version, the terminal supports the following RFID readers:

- MRD - LEGIC prime/advant, MIFARE Classic/DESFire
- HID - iCLASS SE, iCLASS, Prox

Booking via Smartphone (optional)

The following technologies are supported:

- NFC (Android Smartphone)
- Bluetooth Low Energy (Android Smartphone + iPhone)

Ambient conditions**Ingress protection according to IEC 60529**

- IP20
- IP65 (with optional cable sealing)

Relative humidity

- 5% - 85%, non-condensing

Ambient temperature

- -25 °C – +55 °C (operation)
- -25 °C – +70 °C (storage)

Dimensions

- Width: 89 mm, height: 177 mm, depth: 32 mm

Conformity

CE This product complies with the standards

EN 62368-1:2014**EN 300 330 V2.1.1****EN 301 489-1 V2.2.0****EN 301 489-3 V2.1.1****EN 62311:2008**

according to the provisions of the EU directives

2014/35/EU - Low Voltage Directive (LVD)

2014/30/EU - Electromagnetic Compatibility Directive (EMC)

2014/53/EU - Radio Equipment Directive (RED)

RoHS This device complies with the regulations of Directive 2011/65/EU.

 You can download the original declaration of conformity in PDF format at www.dormakaba.com/conformity.

In addition, the product also complies with the following standards

UL62368-1:2014**CAN/CSA-22.2 No. 62368-1:2014****FCC Code of Federal Regulations,****FCC Part 15 Class C**

This device complies with part 15 of the FCC Rules. Operation is subject to the following two conditions:

- This device may not cause harmful interference.
- This device must accept any interference received, including interference that may cause undesired operation.

Any changes or modifications not expressly approved by the party responsible for compliance could void the user's authority to operate the equipment.

Model Name: 9600-K6 MRD

FCC ID: NVI-KT9600K6L

IC: 11038A-KT9600K6L

Model Name: 9600-K6 MRD 3G

FCC ID: NVI-KT9600K6L3G

IC: 11038A-KT9600K6L3G

Model Name: 9600-K6 MRD WiFi

FCC ID: NVI-KT9600K6LWL

IC: 11038A-KT9600K6LWL

Model Name: 9600-K6-HID

FCC ID: NVI-KT9600K6H

IC: 11038A-KT9600K6H

Model Name: 9600-K6-HID 3G

FCC ID: NVI-KT9600K6H3G

IC: 11038A-KT9600K6H3G

Model Name: 9600-K6-HID WiFi

FCC ID: NVI-KT9600K6HWL

IC: 11038A-KT9600K6HWL

Device structure

The product consists of the terminal housing (1) and the mounting plate (2).

The mounting plate (2) is the wall-mounting element of the device. The terminal (1) is hung into the mounting plate (2) and secured with two screws (4) from below.

The network cable is led to the terminal from the rear. The network connection is located on the rear of the terminal.

The product has a magnetic sabotage contact (3). The terminal software uses it to detect when the housing is removed from the mounting plate and generates an alarm record.

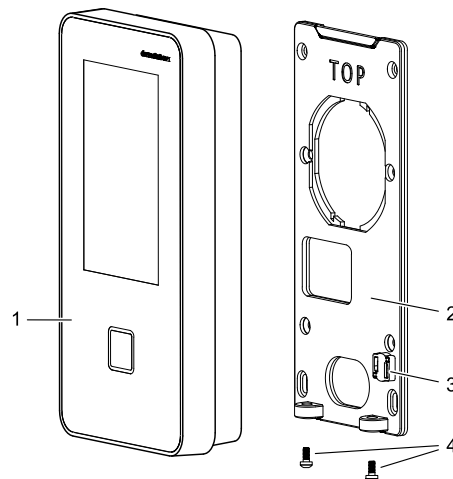
**Installation****Mounting height**

Recommended mounting height 140 cm to the top edge of the terminal.

The mounted height for the terminal should not be higher than 2 meters.

Fastening the mounting plate

The mounting plate can be installed directly on the wall or on a double switch box according to DIN 49073-1. The mounting plate has 4 fastening holes for each of the two fastening variants.

For direct fastening of the mounting plate to the wall, 4 dowels SX6 and 4 suitable screws are included in the delivery.

For fastening the mounting plate to a switch box, 4 countersunk screws are included in the delivery.

When mounting on different surfaces, use suitable fastening material.

If you use other fastening screws, make sure that the flat head of the screw disappears completely in the perforation in the mounting plate.

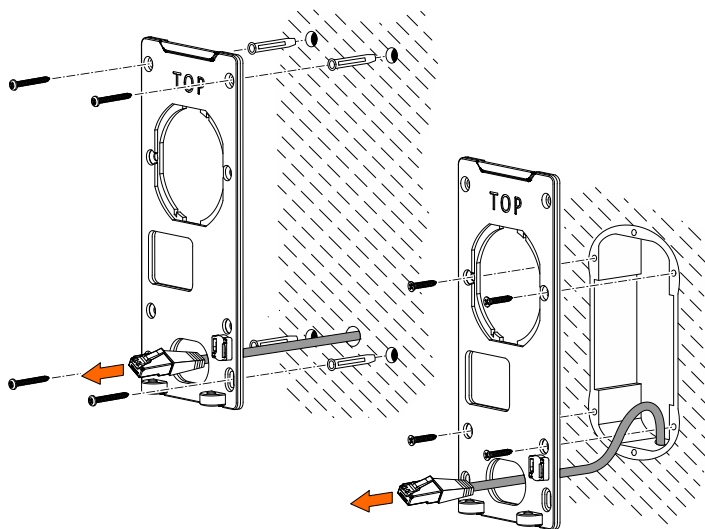

The mounting plate may not be mounted twisted. The screws may only be tightened slightly. The mounting plate may not be deformed or bent.

In case of soft mounting surfaces, make sure that the housing is not pressed into the surface when mounting it. The unevenness of the mounting surface may not exceed 0.5 mm. The unevenness of the mounting surface may have to be compensated for or adjusted by means of suitable measures (e.g. washers).

Connecting the network cable

The Ethernet connection (RJ45 socket) is located on the rear of the terminal housing.

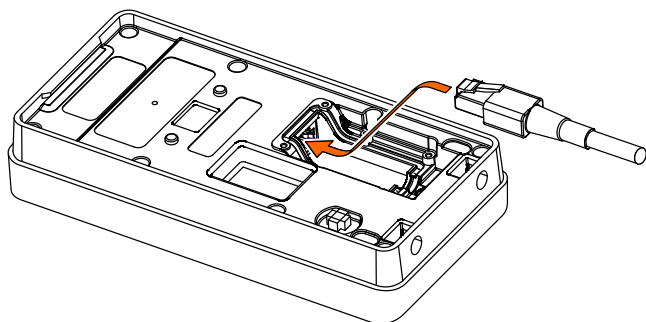

Fastening the sealing cap

The increased ingress protection according to IEC 60529 specified in the technical data is only reached when using this additional cable cover.

The sealing cap for cable sealing is an optional accessory of the terminal 96 00.

Scope of delivery

- 1x sealing cap
- 1x seal with cable passage \varnothing 5.7 mm
- 1x seal with cable passage \varnothing 8.2 mm
- 1x self-adhesive foam strip 1.0 mm thick
- 1x self-adhesive foam strip 2.0 mm thick
- 6x fillister head self-tapping screw
- 1x TORX screw wrench T6

Principle

The sealing cap is fastened to the rear of the terminal via the network connection. Depending on the diameter of the network cable, additional measures for sealing the cable entry are required.

- 1 Use seal with corresponding cable passage.
- 2 Attach a semicircular foam strip to the cable entry of the terminal housing.
- 3 Wrap foam strip around the network cable using full circles in the area of the cable entry.

Cable	1	2	3
\varnothing 4.5 mm - \varnothing 5.5 mm	\varnothing 5.7 mm	1 mm	2 mm
\varnothing 5.6 mm - \varnothing 6.0 mm	\varnothing 5.7 mm	-	-
\varnothing 6.1 mm - \varnothing 7.0 mm	\varnothing 8.2 mm	-	2 mm
\varnothing 7.1 mm - \varnothing 7.5 mm	\varnothing 8.2 mm	-	-
\varnothing 7.6 mm - \varnothing 8.5 mm	\varnothing 8.2 mm	-	1 mm

Procedure

- 1 If required, attach foam strip (see table).
- 2 Connect the network cable.

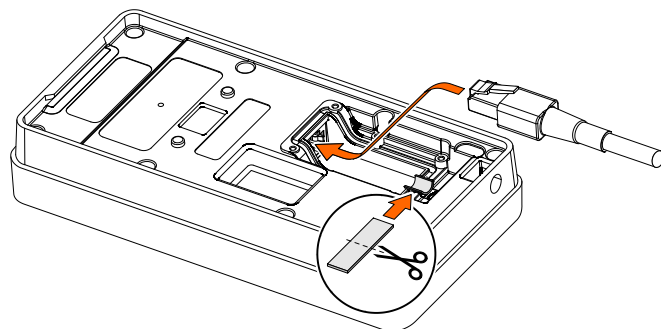

- 3 Insert the seal with suitable cable passage (see table) into the sealing cap.

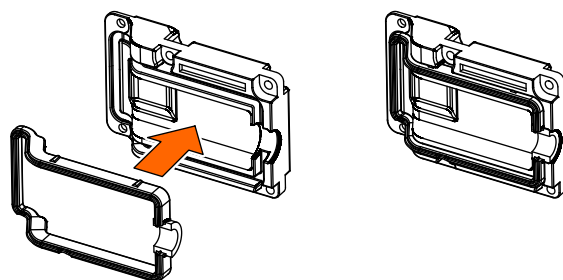

4. Fasten the sealing cap above the connection area using 6 screws.

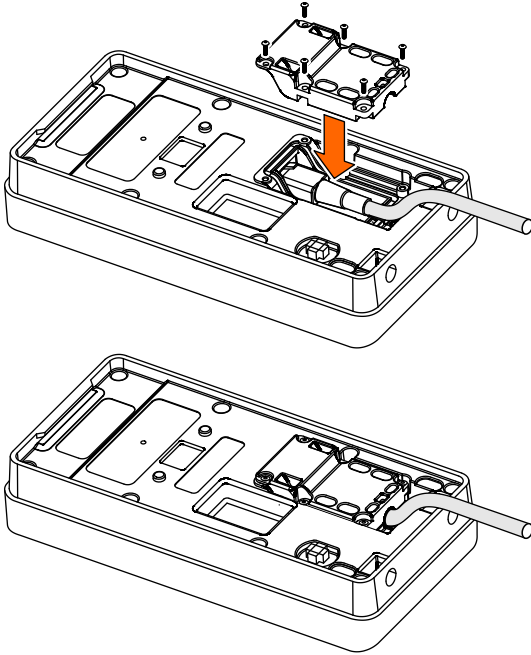

Fastening the terminal to the mounting plate

1. Hang terminal into the mounting plate at the top and press against it at the bottom.
2. Secure terminal housing on the mounting plate using 2 screws M3x6.

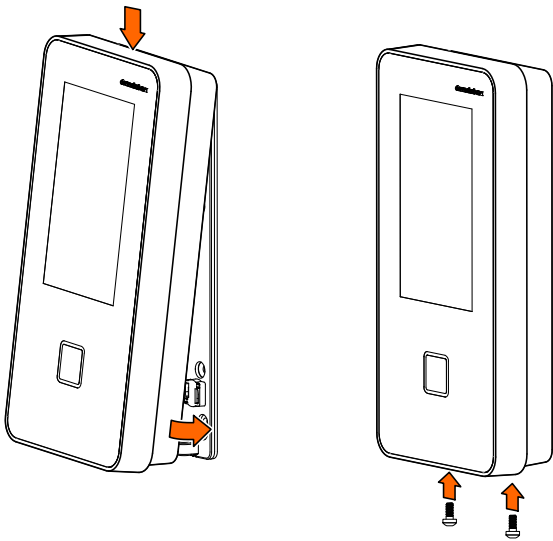

Commissioning

Network requirements

The network must have been equipped with a working DHCP server.

It must be possible to transfer UDP data packages unhindered to the B-COMM server.

- IP address 239.255.255.250, UDP port 1900 dec. and UDP port 7900 (30976 dec.) must have been enabled.
- The SSDP service has to be enabled in the Windows service management.
- The SFTP connection via the standard port 22 must have been enabled.

Automatic registration via B-COMM

Start-up of the terminal takes place largely automatically in connection with the communication software B-COMM.

i The device is preset at the factory for automatic registration via B-COMM.

For communication via WLAN, the connection must have been previously set up and activated. This is done via the system settings.

System requirements

- B-COMM communication software version 3.17.1 and higher.
- Network with a working DHCP server.

Start-up procedure

1. Connect the power supply for the device.
 - ⇒ After booting, the device cyclically reports to the B-COMMs active in the network.
 - ⇒ At this point, until start-up by a B-COMM is complete, the message **'Waiting for registration'** is displayed on the display.
 - ⇒ Once the device is detected by B-COMM, the relevant data that identifies the device will be queried.
 - ⇒ If the device is not known, it will be entered in B-COMM under the B-COMM Terminal Discovery client under BCTDS (Terminal Discovery Stream).
2. Add device in B-COMM to the desired communication channel.
3. Provide device with the appropriate communication parameters.
 - ⇒ After having assigned the device permanently to B-COMM, B-COMM first updates the settings of the device and then makes a backup of the settings together with the 'sop.ini' licence file.
 - ⇒ The device now reports to the B-COMMs active in the network that registration has been carried out, after which the device will be removed again from the BCTDS stream by the other B-COMMs.
4. Load specific parameters and master records to the device.
 - ⇒ The terminal software is restarted automatically. After that, the device is ready-to-operate.

Devices with MRD reader (multi-reader device)

Devices with MRD reader support LEGIC or MIFARE media, depending on the reader type set.

For LEGIC media, the 'LEGIC' reader type has been factory-preset. For processing MIFARE media, the reader type must be changed to 'MIFARE'.

The reader type can be adjusted in the following ways:

- Locally on the device via the test program or service interface
- Remote via the service interface
- Via the B-COMM communication software

CAUTION RISK OF EXPLOSION IF BATTERY IS REPLACED BY AN INCORRECT TYPE. DISPOSE OF USED BATTERIES ACCORDING TO THE INSTRUCTIONS.

RF exposure information: The Maximum Permissible Exposure (MPE) level has been calculated based on a distance of $d=20$ cm between the device and the human body. To maintain compliance with RF exposure requirement, use product that maintain a 20cm distance between the device and human body.

Operating Frequency Range: BT:2402~2480MHz; RFID:13.56MHz;
Max EIRP: BT:3.52dBm;

Federal Communication Commission (FCC) Radiation Exposure Statement:

When using the product, maintain a distance of 20cm from the body to ensure compliance with RF exposure requirements.

FCC statements:

This device complies with part 15 of the FCC rules. Operation is subject to the following two conditions: (1) this device may not cause harmful interference, and (2) this device must accept any interference received, including interference that may cause undesired operation.

NOTE: The manufacturer is not responsible for any radio or TV interference caused by unauthorized modifications or changes to this equipment. Such modifications or changes could void the user's authority to operate the equipment.

NOTE: This equipment has been tested and found to comply with the limits for a Class B digital device, pursuant to part 15 of the FCC Rules. These limits are designed to provide reasonable protection against harmful interference in a residential installation. This equipment generates uses and can radiate radio frequency energy and, if not installed and used in accordance with the instructions, may cause harmful interference to radio communications. However, there is no guarantee that interference will not occur in a particular installation. If this equipment does cause harmful interference to radio or television reception, which can be determined by turning the equipment off and on, the user is encouraged to try to correct the interference by one or more of the following measures:

- Reorient or relocate the receiving antenna.
- Increase the separation between the equipment and receiver.
- Connect the equipment into an outlet on a circuit different from that to which the receiver is connected.
- Consult the dealer or an experienced radio/TV technician for help.

IC Notice:

This Class B digital apparatus complies with Canadian ICES-003.

Cet appareil numérique de la classe B est conforme à la norme NMB-003 du Canada.

This device complies with Canada Industry licence-exempt RSS standard(s). Operation is subject to the following two conditions: (1) this device may not cause interference. and (2) this device must accept any interference. Including interference that may cause undesired operation of the device.

CAN ICES-3 (B)

Le présent appareil est conforme aux CNR d'Industrie Canada applicables aux appareils radio exempts de licence.

L'exploitation est autorisée aux deux conditions suivantes :

(1) l'appareil ne doit pas produire de brouillage; (2) l'utilisateur de l'appareil doit accepter tout brouillage radioélectrique subi, même si le brouillage est susceptible d'en compromettre le fonctionnement.

NMB-3 (B)

When using the product, maintain a distance of 20cm from the body to ensure compliance with RF exposure requirements.

Lors de l'utilisation du produit, maintenez une distance de 20 cm du corps afin de vous conformer aux exigences en matière d'exposition RF.