

Copy/keep
To: T111

We reserve all rights in this document and in the information contained therein. Reproduction, use or disclosure to third parties without express authority is strictly forbidden. Copyright © Network Engineering AB

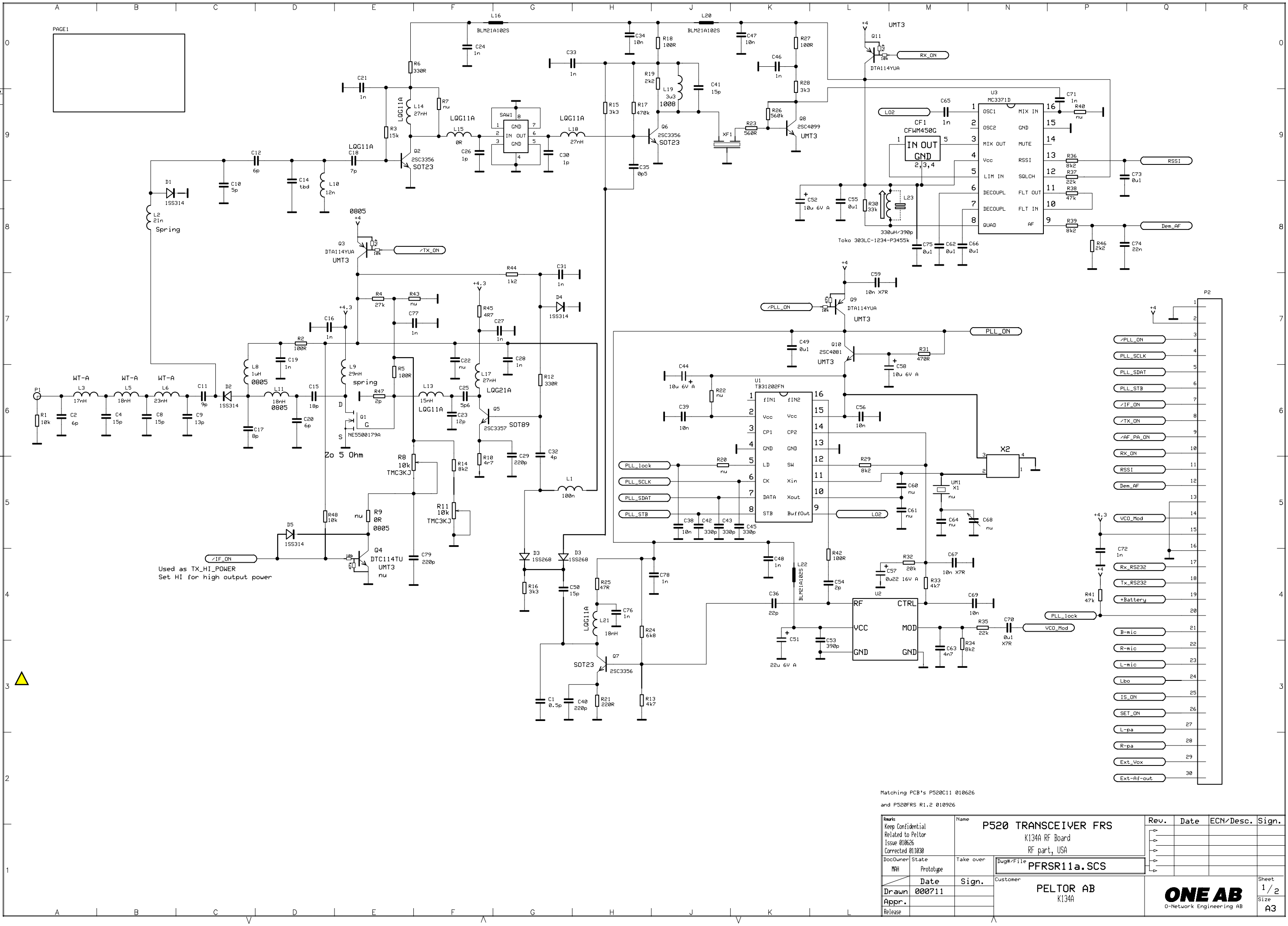

Used as TX_HI_POWER
Set HI for high output power

Matching PCB's P520C11 010626
and P520FRS R1.2 010926

Rev.	Date	ECN/Desc.	Sign.

Name P520 TRANSCEIVER FRS K134A RF Board RF part, USA	DocOwner MWH	State Prototype	Take over Date 000711	Bug#/File PFRSR11a.SCS	Customer PELTOR AB K134A	Sheet 1/2 Size A3
---	-----------------	--------------------	-----------------------------	----------------------------------	---------------------------------------	--

Name P520 TRANSCEIVER FRS K134A RF Board RF part, USA	DocOwner MWH	State Prototype	Take over Date 000711	Bug#/File PFRSR11a.SCS	Customer PELTOR AB K134A	Sheet 1/2 Size A3
---	-----------------	--------------------	-----------------------------	----------------------------------	---------------------------------------	--



Copy/kill	
To	
File	

We reserve all rights in this document and in the information contained herein. Reproduction, use or disclosure to third parties without express authority is strictly forbidden. Copyright © Network Engineering AB

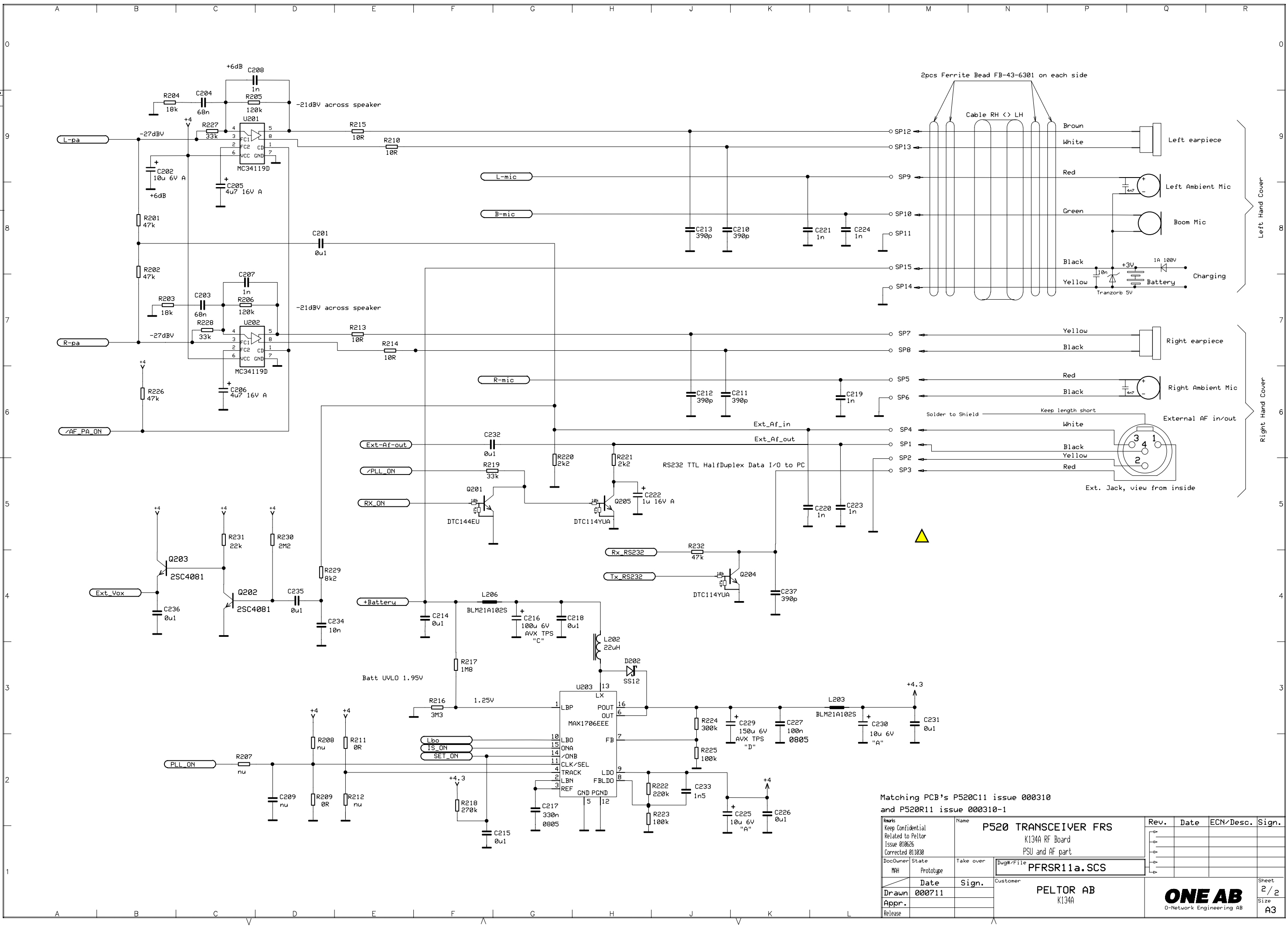

Matching PCB's P520C11 issue 000310
and P520R11 issue 000310-1

Name P520 TRANSCEIVER FRS		Rev.	Date	ECN/Desc.	Sign.
Keep Confidential Related to Peltor Issue 010626 Corrected 011030					
DocOwner State MH Prototype		Take over	Dug# / File PFRSR11a.SCS		
Date 000711	Sign.	Customer PELTOR AB K134A		Sheet 2/2	Size A3
Appr.		ONE AB O-Network Engineering AB			
Release					