

4

3

PDM REF

D: A.3

M: A.3

1

NOTES: UNLESS OTHERWISE SPECIFIED

I. FCC ID LABEL ON THE SBD - CONVERT DAUGHTER CARD, PCBA# 450-00041-002 AS THE FOLLOWING:

- A. IC: 3022A-450412ZWV
WHERE IC --- INDUSTRY CANADA
WHERE 3022A-450412ZWV --- INDUSTRY CANADA NUMBER
- B. FCC ID: NUL450412ZWV
WHERE NUL --- FIRST THREE CHARACTERS OF GRANTEE CODE
WHERE 450412ZWV --- REMAINING NUMBERS/CHARACTERS FCC ID
- C. MODEL: 450412.
WHERE 450412 --- INTERNAL HHI FCC MODEL NUMBER.
- D. LABEL COLOR: BLACK.
- E. LABEL MATERIAL:
REFER TO 695-00006-001 FOR LABEL SPECIFICATION.
- F. FONT: FIT ON LABEL, WHITE.
- G. LABEL LOCATION: REFER TO DRAWING 5049806.
- H. ALL DIMENSIONS ARE IN INCHES.

REV	DESCRIPTION	DATE	DRAFTER	ENGINEER	APPROVED
A	PRELIMINARY	08/18/16	L. LIN	C. BECK	N. ALMOMANI

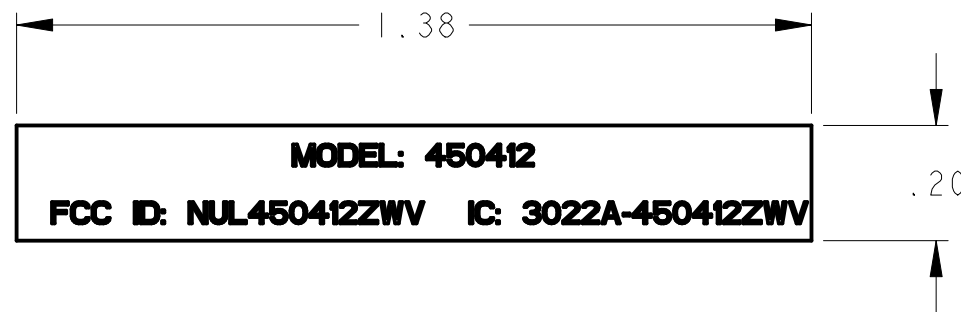
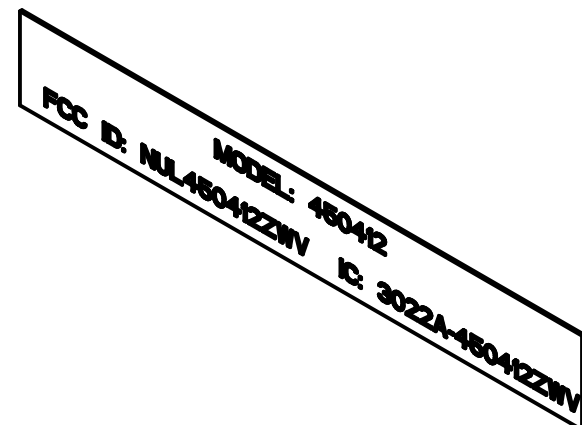

DRAFTER L. LIN	DATE 08/18/16	SPECTRUM BRANDS, INC HARDWARE AND HOME IMPROVEMENT 19701 DA VINCI, LAKE FOREST, CA 92610	
CHECKED B. QUACH	DATE 08/18/16	TITLE LABEL, FCC, Z-WAVE, CONVERT	
ENGINEER C. BECK	DATE 08/18/16	SIZE B	DO NOT SCALE DRAWING
APPROVED N. ALMOMANI	DATE 08/18/16	DWG NO 5064846	
THIRD ANGLE PROJECTION 		RELEASE STATE Preliminary	REV ITER A 3
		SCALE 3/1	SHEET 1 OF 2

KWIKSET
Spectrum Brands | Hardware & Home Improvement

THIS DOCUMENT IS THE PROPERTY OF SPECTRUM BRANDS, INC AND/OR ITS AFFILIATES. THE CONTENTS OF THIS DOCUMENT ARE CONFIDENTIAL AND CONSTITUTE TRADE SECRETS PROPRIETARY TO SPECTRUM BRANDS. NEITHER THIS DOCUMENT NOR ITS CONTENTS SHALL BE DISCLOSED TO ANY UNAUTHORIZED PERSON, COPIED, OR PUBLISHED WITHOUT SPECTRUM BRANDS' PRIOR WRITTEN CONSENT.

4

3

2

1

D

D

C

C

B

B

A

A

4

3

PDM REF

D: A.3

M: A.3

1

REV	DESCRIPTION
A	SEE SHEET 1

D

D

C

C

B

B

A

A

MODEL: 450412
FCC ID: NUL450412ZWW IC: 3022A-450412ZWW

TITLE
LABEL, FCC, Z-WAVE, CONVERT

SIZE **B** DO NOT SCALE DRAWING DWG NO **5064846**

RELEASE STATE **Preliminary** REV **A** ITER **3**

SCALE **3/1** SHEET **2 OF 2**

KWIKSET
Spectrum Brands | Hardware & Home Improvement

THIS DOCUMENT IS THE PROPERTY OF SPECTRUM BRANDS, INC AND/OR ITS AFFILIATES. THE CONTENTS OF THIS DOCUMENT ARE CONFIDENTIAL AND CONSTITUTE TRADE SECRETS PROPRIETARY TO SPECTRUM BRANDS. NEITHER THIS DOCUMENT NOR ITS CONTENTS SHALL BE DISCLOSED TO ANY UNAUTHORIZED PERSON, COPIED, OR PUBLISHED WITHOUT SPECTRUM BRANDS' PRIOR WRITTEN CONSENT.

4

3

2

1

4

3

1

NOTES: UNLESS OTHERWISE SPECIFIED

- 1. INTERPRET DIMENSIONS PER ASME Y14.5M-1994.
- 2. REFER TO PRO/E MODEL 5064847 FOR DIMENSIONS NOT SHOWN.
- 3. DIMENSIONS ARE IN INCHES.
- 4. TOLERANCES: .XX ± .01
.XXX ± .005
ANGLES ± 1°
- 5. REFER TO 405-00041-002 FOR COMPLETE BOM.

REV	DESCRIPTION	DATE	DRAFTER	ENGINEER	APPROVED
1	PRODUCTION RELEASE PER EO11799-07	01/03/17	L. LIN	C. BECK	N. ALMOMANI

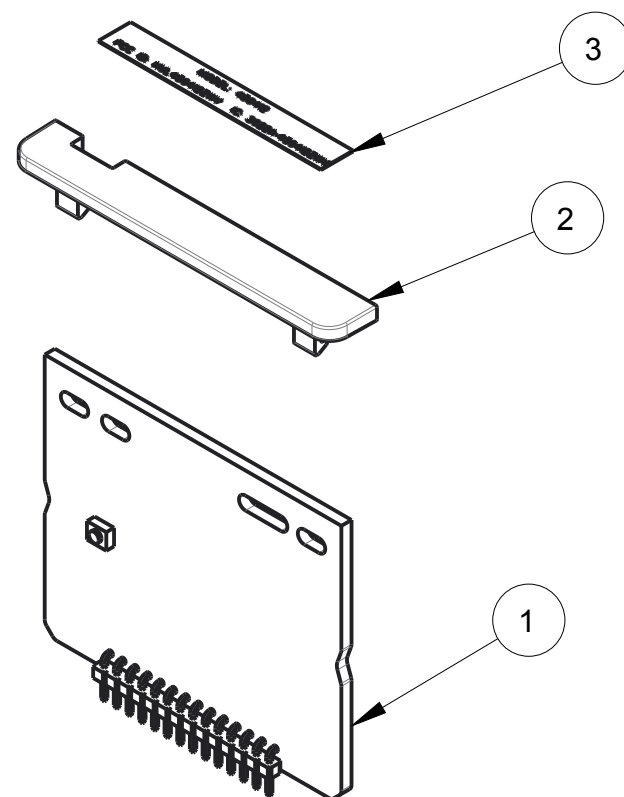
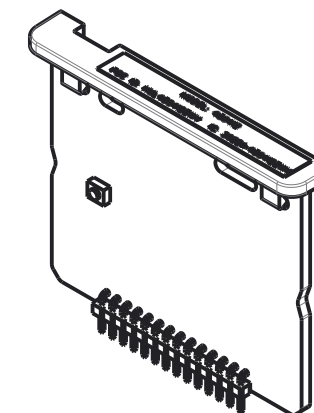
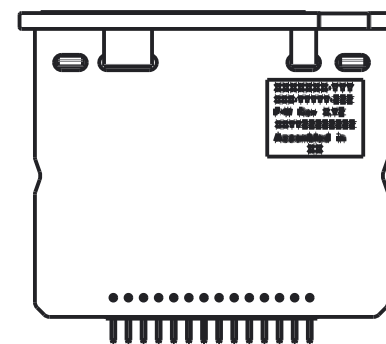

ITEM NO.	PART NO.	DESCRIPTION	QTY
3	5064846	LABEL, FCC, Z-WAVE, CONVERT	1
2	5024085	HANDLE, WIRELESS BOARD	1
1	450-00041-002	PCBA, Z-WAVE, CONVERT	1

DRAFTER L. LIN	DATE 08/18/16	SPECTRUM BRANDS, INC HARDWARE AND HOME IMPROVEMENT 19701 DA VINCI, LAKE FOREST, CA 92610			
CHECKED B. QUACH	DATE 08/18/16	TITLE SA, PCBA, Z-WAVE, CONVERT			
ENGINEER C. BECK	DATE 08/18/16	SIZE B	DO NOT SCALE DRAWING	DWG NO 5064847	
APPROVED N. ALMOMANI	DATE 08/18/16	THIRD ANGLE PROJECTION		RELEASE STATE Preliminary	REV A
		SCALE 1/1	SHEET 1 OF 1		ITER 5

KWIKSET

Spectrum Brands | Hardware & Home Improvement

THIS DOCUMENT IS THE PROPERTY OF SPECTRUM BRANDS, INC AND/OR ITS AFFILIATES. THE CONTENTS OF THIS DOCUMENT ARE CONFIDENTIAL AND CONSTITUTE TRADE SECRETS PROPRIETARY TO SPECTRUM BRANDS. NEITHER THIS DOCUMENT NOR ITS CONTENTS SHALL BE DISCLOSED TO ANY UNAUTHORIZED PERSON, COPIED, OR PUBLISHED WITHOUT SPECTRUM BRANDS' PRIOR WRITTEN CONSENT.

4

3

2

1



WS Packaging Group, Inc.®

Leaders in Printing and Packaging Worldwide

PRODUCTION SPECIFICATION SHEET

Item Code: R2WPET-PERM-50KRAF-104

Old FAL: 0097-0H52-0002

Total Construction Caliper: 6 mils +/- 10%

FACESHEET: A white topcoated polyester featuring excellent tear strength, heat resistance, dimensional stability, opacity, and chemical resistance. Excellent thermal transfer printability with some resin enhanced wax and most resin based ribbons.

Caliper: 2 mil +/- 10%

ADHESIVE: A high performance permanent adhesive with balanced adhesion to a wide variety of substrates, including low surface energy plastics, engineering grade plastics, bare, coated, or painted metals, including powder coat and enamel paints. It features medium tack and excellent chemical and UV resistance for outdoor industrial applications.

Minimum Application Temperature: +50° F

Service Temperature Range: - 40°F - + 302° F

LINER: A 50# bleached super-calendered paper kraft liner for roll to roll label applications.

Caliper: 3.2 mil +/- 10%

UL and c-UL Recognized.

Shelf Life:

One year when stored at 72°F at 50% RH

All original documents remain on file at WS Packaging Group, Algoma, Wisconsin.