





kēvo CONVERT

Required tools

Ruler



Phillips screwdriver



Existing key



Parts in the box

Kit "A"

Mounting plate

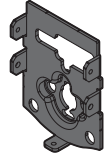

Adapter



Interior assembly screws



Mounting plate screws



Interior cover screws



Kit "B"

Mounting plate

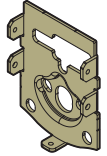

Adapters



Interior assembly screws



Mounting plate screws



Interior cover screws



Kit "C"

Mounting plate

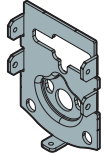

Adapters



Interior assembly screws



Mounting plate screws



Interior cover screws



Interior cover

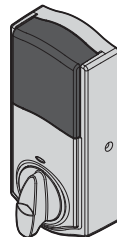

Interior assembly

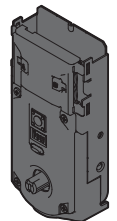

Battery pack



AA batteries



1 Make sure your existing deadbolt is compatible.

If you have a standard deadbolt mounted separately from the handle below it, it is compatible with Kevo Convert.

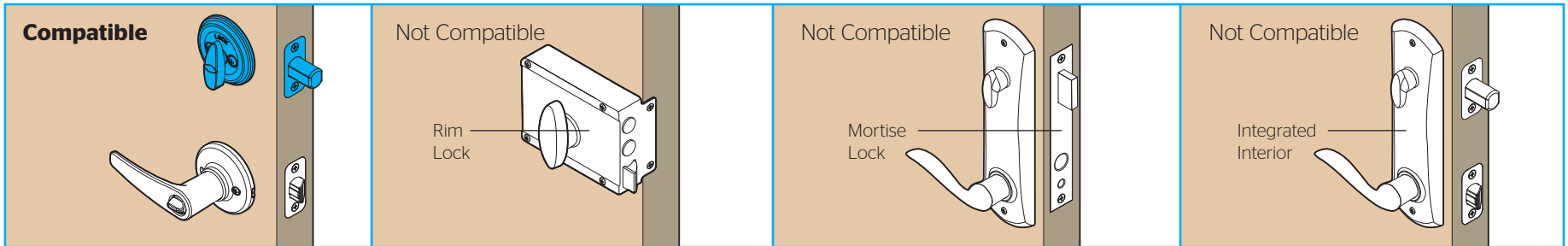

2 Measure the thickness of your door.

Measure to confirm that your door is either 1-3/8" or 1-3/4" (35 mm or 44 mm) thick.

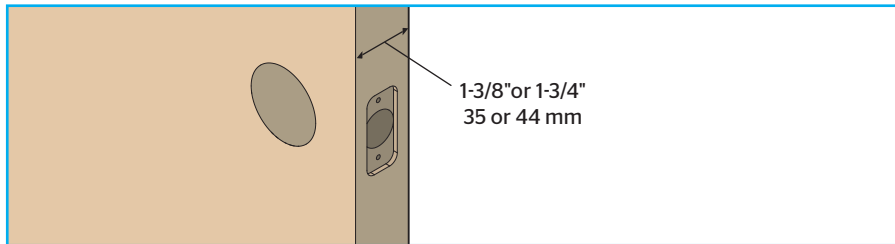

3 Disassemble your existing deadbolt.

A Make sure your door is open and extend your latch bolt.

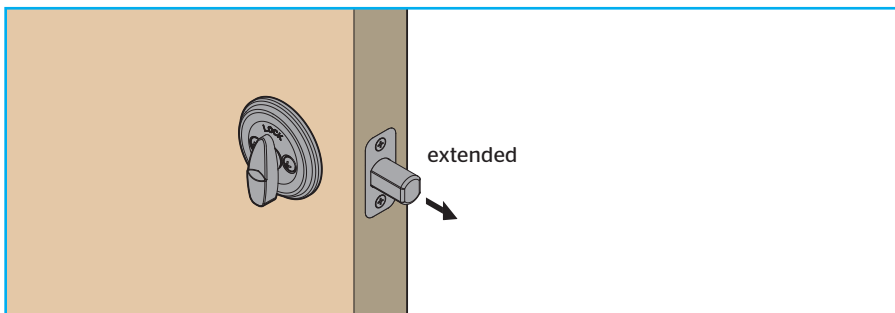

B Remove all existing deadbolt hardware from the interior side of your door. Keep your deadbolt exterior in place.

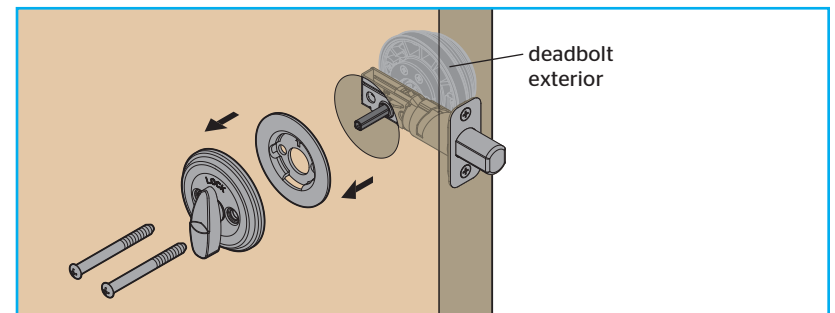

4

Determine the parts needed for your door.

For a list of compatible deadbolt models, please see page 11.

Look at the hole in your door.
What shape is your torque blade (the part sticking out through the latch)?

D-shape

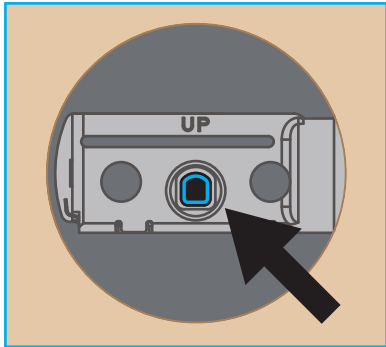

Kwikset and Weiser deadbolts:

Use kit "A" for your door.



Baldwin Reserve and Baldwin Prestige deadbolts:

Use kit "B" for your door.

You will need the black adapter and the thicker gold screws.

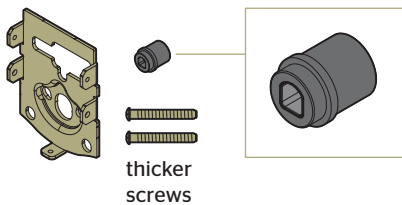

Vertical rectangle

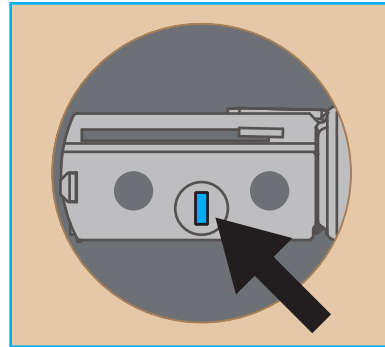

Baldwin Estate deadbolts:

Use kit "B" for your door.

You will need the gold adapter and the thinner gold screws.

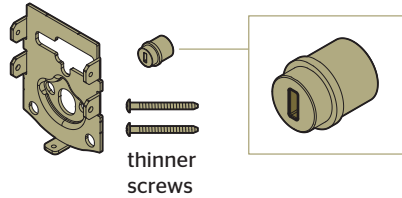

Slanted rectangle

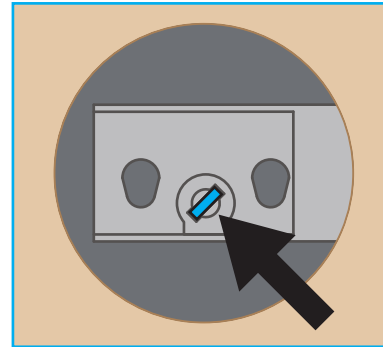

Schlage deadbolts:

Use kit "C" for your door.

You will need the silver adapter.

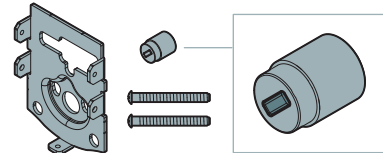

Horizontal rectangle

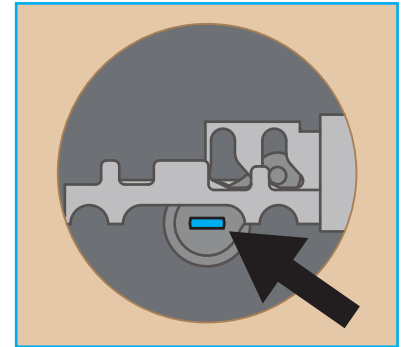

Schlage deadbolts:

Use kit "C" for your door.

You will need the gold adapter.

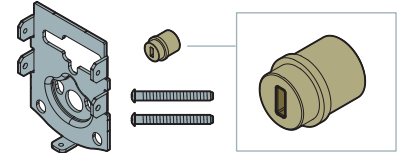

5 Install the mounting plate and test your latch.

- A** Place the mounting plate on the door so that the torque blade inserts through the center hole.

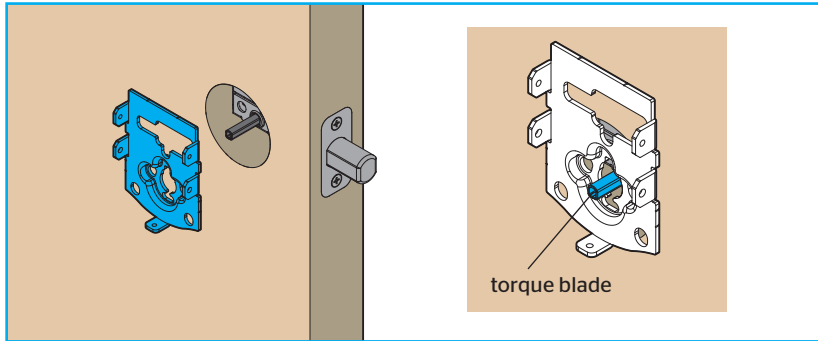

Note: A D-shaped torque blade is shown, but installation is the same for all models.

- B** Secure the mounting plate with the mounting screws.

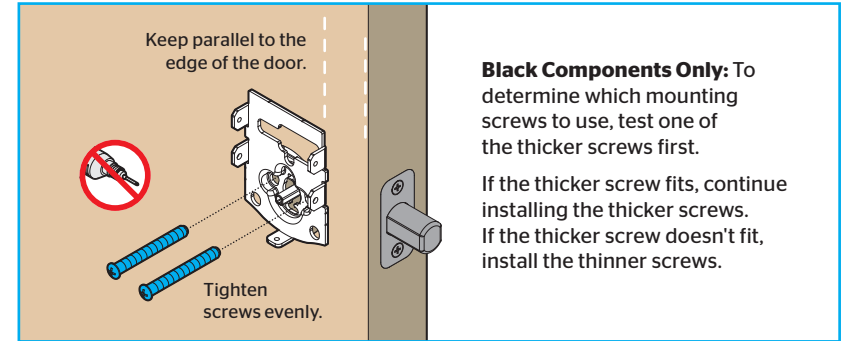

- C** Insert your key and test the latch for smooth operation.

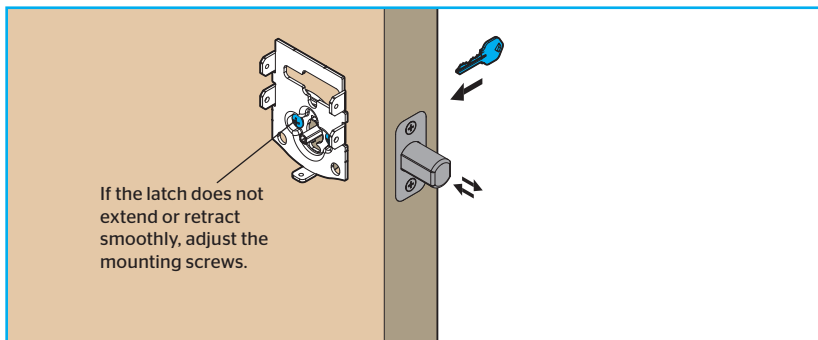

- D** Remove your key and make sure the bolt is fully extended.

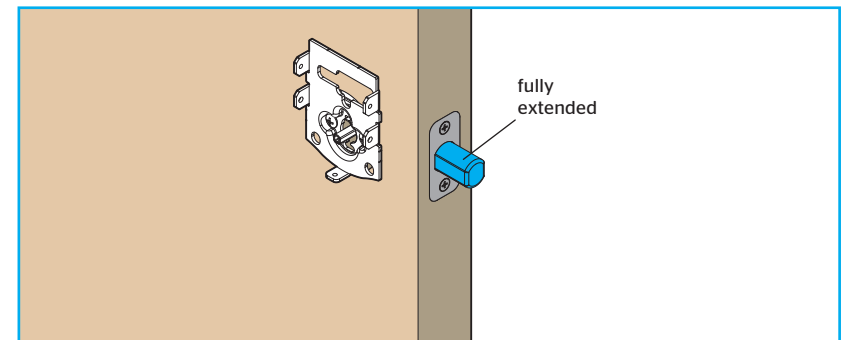

6 Install the interior assembly.

A Prepare the interior assembly.

- a** Make sure the turnpiece is in the vertical position.

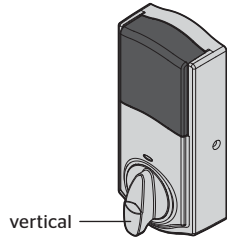

- b** Remove the interior cover.

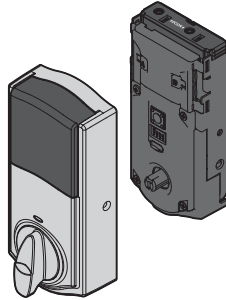

- c** Make sure shaft is oriented as shown. If needed, rotate the shaft to this position.

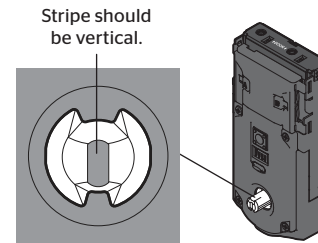

- d** Remove the battery pack.

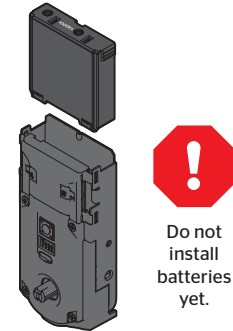

B Install the adapter on the interior assembly.

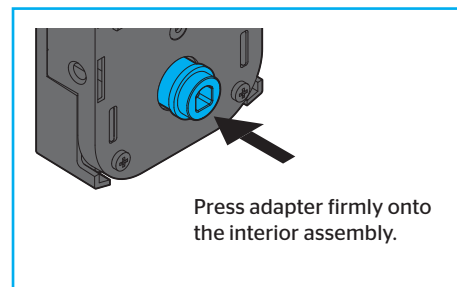
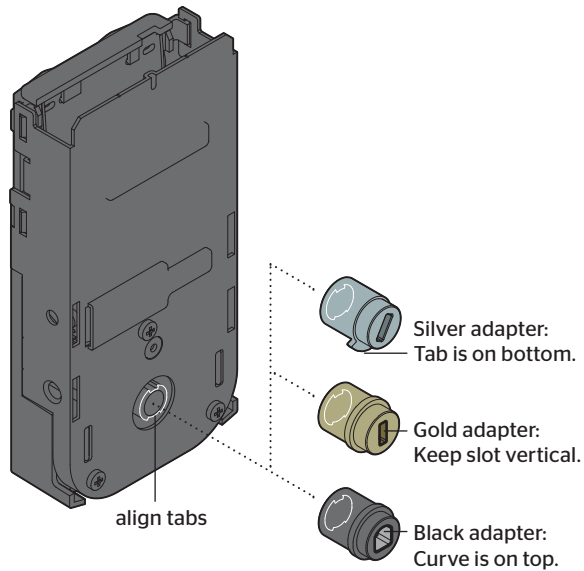

6

Install the interior assembly (continued).



SCHLAGE DEADBOLTS ONLY:

Look at your mounting plate.
Is your latch bolt to the left or right of your mounting plate?

Left

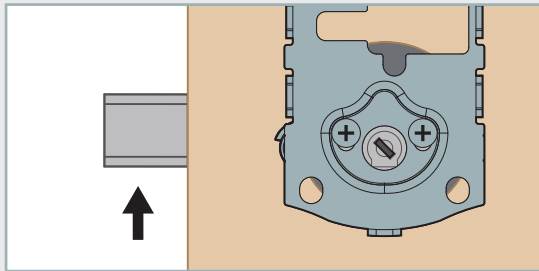

No adjustment is required.
Proceed to the next page.

Right

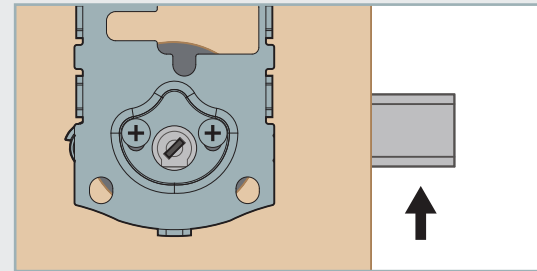

On your interior assembly, flip switch #2
to the top position.

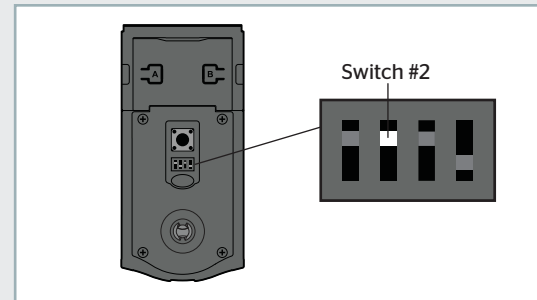

6 Install the interior assembly (continued).

C Install the interior assembly onto the mounting plate.

a Align the adapter with the torque blade.

Schlage deadbolts only:

You may need to rotate the adapter to align with the torque blade.

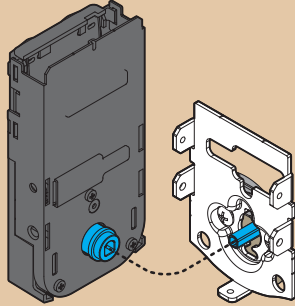

b Secure with two (2) interior assembly screws.

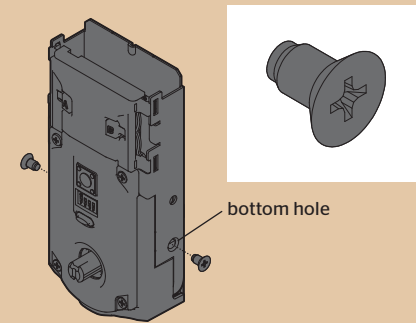

7 Perform the door handing process.

This step will teach the lock the orientation of your door and is crucial for lock operation.

A Install 4 AA batteries in the battery pack.

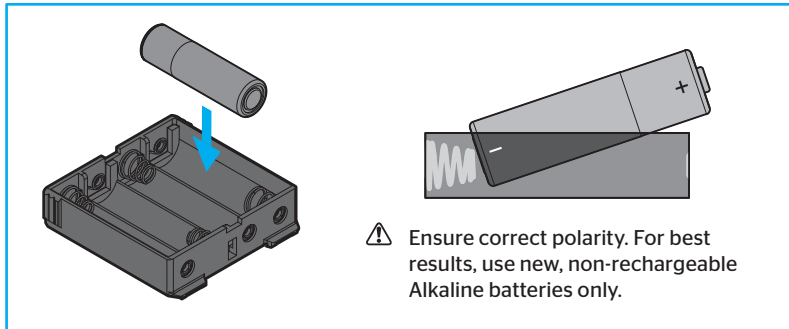

B **IMPORTANT:** Make sure the door is open. Insert the battery pack while **PRESSING AND HOLDING** the Program button. Release the button when the battery pack is all the way inside the lock interior.

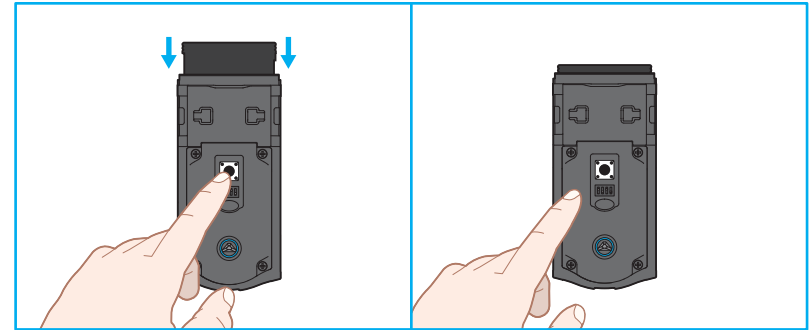

C **IMPORTANT:** The Status LED will flash red and green, and the lock will beep. Press and release the Program button again.

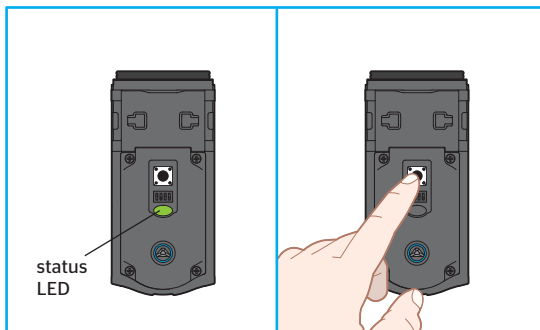

D The latch bolt will retract and extend on its own to learn the orientation of the door.

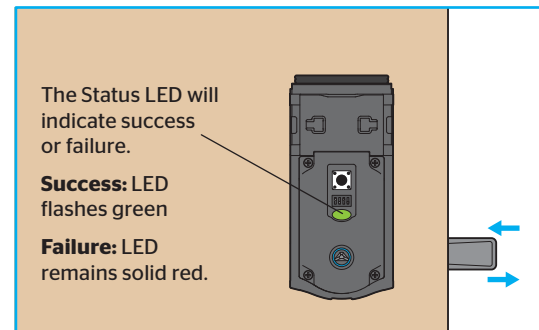

! **BALDWIN ESTATE DEADBOLTS ONLY:**
If your latch bolt is to the **RIGHT** of your interior assembly, and the Status LED indicates a failure, **press and release the Program button again**. The door handing process will restart.

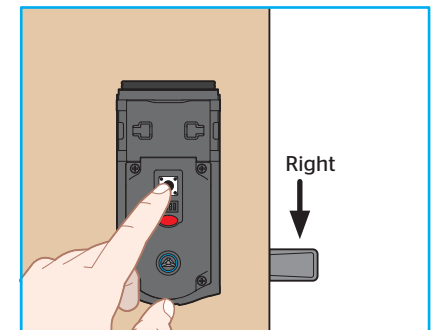

OTHER DEADBOLTS:

If the latch bolt does not move on its own, or if the Status LED indicates a door handing failure, make sure the batteries are installed correctly, and perform steps B-D again.

8 Download the Kevo app and set up your smartphone.

A Download the Kevo app at kwikset.com/kevo/app or scan the QR code below.



B Follow the instructions inside the app to create an account, enroll your first smartphone and send eKeys to family and friends.



9

Install the interior cover.

Important information about the interior cover:

The interior cover will be secured by three screws to prevent someone from removing the battery or tampering with your lock's settings.

The window on the interior cover is locked by default.

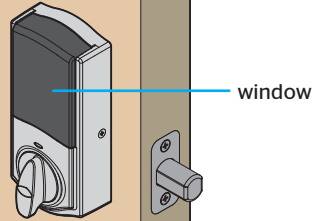

If the window is unlocked, it can slide up for more convenient access to programming buttons while the cover is installed.

Note: The interior cover and screws must be removed for battery pack access.

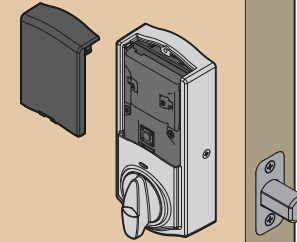

If you want to keep the window locked:

a Install the cover.

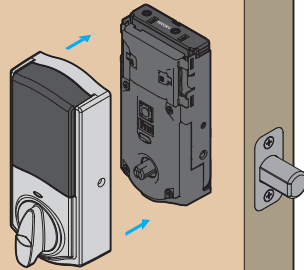

b Secure the cover with three (3) interior cover screws.

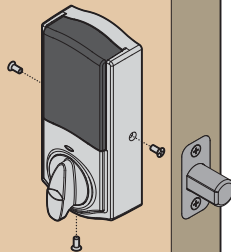

If you want to unlock the window:

a Remove the security screw.

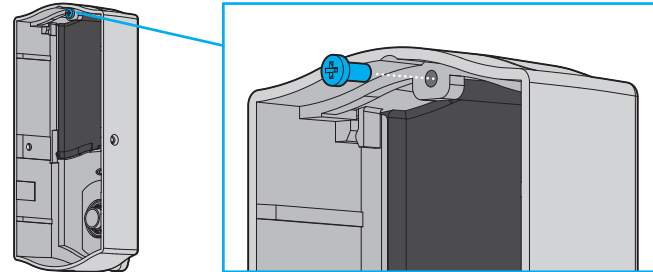

b Install the cover.

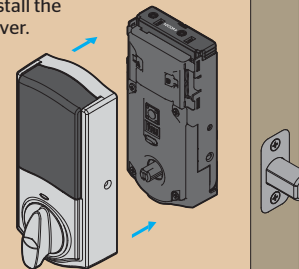

c Secure the cover with three (3) interior cover screws.

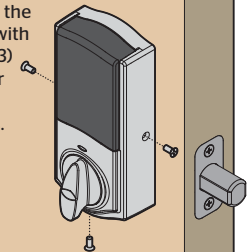

Kevo Convert Compatibility Chart

Kevo Convert is compatible with the following models:

Kwikset

<i>Model</i>	<i>Kit</i>	<i>Mounting plate</i>	<i>Adapter</i>	<i>Screws</i>
158	A	Black	Black	Thick
660	A	Black	Black	Thin
660M	A	Black	Black	Thin
780	A	Black	Black	Thick
816	A	Black	Black	Thick
980	A	Black	Black	Thick
980AUD	A	Black	Black	Thick
993	A	Black	Black	Thick

Weiser

<i>Model</i>	<i>Kit</i>	<i>Mounting Plate</i>	<i>Adapter</i>	<i>Screws</i>
GDC9471	A	Black	Black	Thin
GCD9471	A	Black	Black	Thick
GCD9571	A	Black	Black	Thick
SSD9471	A	Black	Black	Thick

Schlage

<i>Model</i>	<i>Kit</i>	<i>Mounting plate</i>	<i>Adapter</i>
B360N	C	Silver	Gold
B560P	C	Silver	Silver
B60N	C	Silver	Silver
B660P6	C	Silver	Silver
B760P	C	Silver	Silver

Baldwin

<i>Model</i>	<i>Kit</i>	<i>Mounting plate</i>	<i>Adapter</i>	<i>Screws</i>
All Baldwin Prestige 380 Deadbolts	B	Gold	Black	Thick
All Baldwin Reserve single cylinder deadbolts	B	Gold	Black	Thick
All Baldwin Estate single cylinder deadbolts	B	Gold	Gold	Thin

Kevo Convert at a Glance

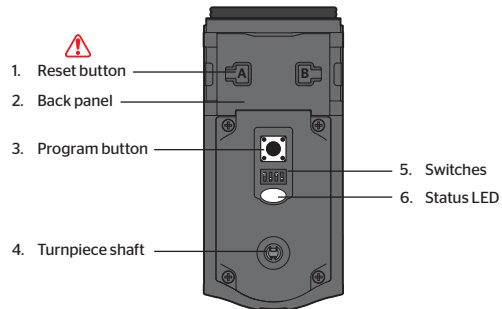

1. ⚠️ Only use to reset Kevo Convert to delete all eKeys from your system. See "System Reset" for more information.
2. Where all the programming features are located.
3. Use to enroll smartphones.
4. Engages with turnpiece when interior cover is installed. When the cover is removed, the turnpiece shaft can be used to manually lock and unlock the door.
5. Use to enable and disable the Status LED, Invert, Audio, and Auto-Lock.
6. Communicates whether the door is locked or unlocked and flashes red for a low battery alert. Can be turned on and off by Switch #1.

Kevo-Compatible Devices

Smartphones and Smart Devices

A Kevo-compatible smartphone (or other mobile internet-connected device or tablet) must have Bluetooth Smart Ready/ Bluetooth 4.0 and an app specific to the device must be installed. Find out if your device is compatible at www.kwikset.com/kevo/devices.



Standard Key

Always make sure you have access to your standard key.

Switches

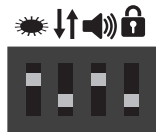

1 2 3 4



Switch 1 Status LED

Door lock status LED blinks every 6 seconds. ON position is factory default.

Switch 2 ⚠️ Invert

Only used for right-handed doors that have installed silver components. See page 6 for details.

Switch 3 Audio

Beeping sound is heard during programming and normal operation. ON position is factory default.

Switch 4 ⚠️ Auto-Lock

Automatically re-locks door 30 seconds after unlocking. OFF position is factory default.

⚠️ **CAUTION:** With this feature enabled, it is possible to lock yourself outside if you don't have an enrolled smartphone or standard key with you.

Status LED Notifications

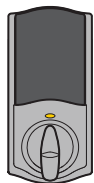

Amber flash
Door is locked

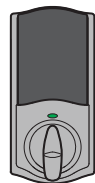

Green flash
Door is unlocked.

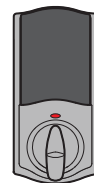

Red flash
The 4 AA batteries in the Kevo interior are low and need to be replaced.

System Reset

⚠️ **WARNING:** Resetting your Kevo system will restore your lock to factory settings and delete all smartphones from Kevo's memory.

If you wish to perform a system reset, **press and hold** the Reset button on the back panel for 10 seconds until the lock beeps.

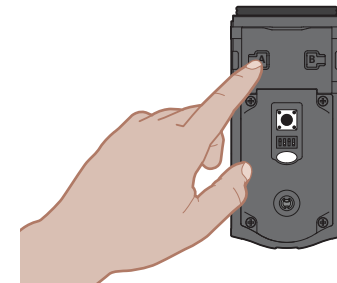

After a system reset, you will need to re-enroll your Owner phone. You will still be able to send eKeys at no charge to anyone who previously had an active eKey at the time of reset.

Advanced Features

History Log

A history of the lock's activity may be viewed through the Kevo app or by logging into the web portal: www.mykevo.com.

Notifications

The Kevo app can send notifications when the door is locked and unlocked by eKey holders. You can choose to receive the system's default notifications or set up custom notifications to monitor a specific user or time frame.

Dual Factor Authentication

Kevo features an optional, added-security passcode that you can enable inside the app to be used in addition to the app's password. Enabling the passcode will require you to enter a 4-digit PIN whenever you access the app, and it protects your Kevo account against unauthorized changes when your phone is unlocked.

Kevo Plus

With Kevo Plus, you will be able to lock and unlock your home and check whether your door is locked or unlocked when you are away from home. You can upgrade to Kevo Plus inside the Kevo app. Visit www.kwikset.com/kevo/kevo-plus for more information.

Connect Smart Products

Connect Kevo to select smart products. In the Kevo app, tap the gear icon to connect to smart products (iOS only: select "Preferences"). Visit www.kwikset.com/kevo/support for more information.

Important Safeguards

1. Read all instructions in their entirety.
2. Familiarize yourself with all warning and caution statements.
3. Remind all family members of safety precautions.
4. Always have access to your lock's standard key.
5. If using the Auto-Lock feature, make sure to have your smartphone or standard key with you to prevent locking yourself out.
6. Replace low batteries immediately.

Preventing Inadvertent Unlocking of Your Door

 **WARNING:** Failure to follow these safeguards could result in your lock opening inadvertently.

1. Restrict access to your Kevo lock's back panel and routinely check your settings to ensure they have not been altered without your knowledge.
2. Protect the password to your Kevo app and web portal accounts.
3. When sending an eKey, always double-check that you are sending it to the correct recipient.
4. Protect and restrict access to your smartphone so that your app settings cannot be altered without your knowledge.
5. Enable the Kevo app's security passcode so that your app settings cannot be altered without your knowledge.
6. When sending eKeys, be aware of the difference between an Admin user and other users in the system: an Admin user can send, disable and delete eKeys.
7. If your smartphone is lost or stolen, use the Kevo web portal (www.mykevo.com) to disable it.

 **WARNING:** This Manufacturer advises that no lock can provide complete security by itself. This lock may be defeated by forcible or technical means, or evaded by entry elsewhere on the property. No lock can substitute for caution, awareness of your environment, and common sense. Builder's hardware is available in multiple performance grades to suit the application. In order to enhance security and reduce risk, you should consult a qualified locksmith or other security professional.



Terms and Conditions Términos y condiciones Termes et conditions

Conformité réglementaire

Ce produit est conforme aux normes établies par les organismes de réglementation suivants :

- Federal Communications Commission (FCC)
- Industrie Canada

FCC

Cet appareil est conforme aux limites prescrites dans la partie 15 des règlements de la Federal Communication Commission (FCC) des États-Unis. Son utilisation est subordonnée aux conditions suivantes : (1) l'appareil ne doit pas causer d'interférence nuisibles, et (2) il doit accepter toute interférence, y compris celles qui peuvent causer son mauvais fonctionnement.

Lors des tests effectués, cet appareil s'est révélé conforme aux limites prescrites dans la partie 15 des règlements de la Federal Communications Commission (FCC) des États-Unis pour un appareil numérique de Classe B. Ces limites ont été fixées pour protéger raisonnablement les installations résidentielles contre les interférences nuisibles. L'appareil produit, utilise et peut émettre des radiofréquences. S'il n'est pas installé et utilisé de la façon prescrite, il peut brouiller les communications radio. Il n'est pas garanti qu'aucune interférence ne se produira. Si l'appareil brouille la réception d'une radio ou d'un téléviseur (pour savoir s'il est à l'origine du brouillage, il suffit de l'éteindre et de le rallumer), l'utilisateur est invité à tenter de corriger la situation en prenant une ou plusieurs des mesures suivantes :

- réorienter ou déplacer l'antenne réceptrice;
- éloigner davantage l'appareil émetteur du récepteur;
- brancher l'appareil dans une prise reliée à un circuit différent de celui auquel le récepteur est relié;
- consulter le détaillant ou un technicien de radiotélévision expérimenté pour obtenir de l'aide.

IMPORTANT! Les modifications qui n'ont pas été expressément approuvées par le fabricant de l'appareil peuvent annuler l'autorisation d'utiliser l'appareil.

Industrie Canada

Cet appareil est conforme aux normes d'Industrie Canada exemptes de licence RSS. L'opération est sujette aux deux conditions: (1) ce dispositif peut ne pas causer l'interférence et (2) ce dispositif doit accepter n'importe quelle interférence, y compris l'interférence qui peut causer le fonctionnement non souhaité du dispositif.

Cumplimiento Normativo

Este producto cumple con las normas establecidas por los siguientes organismos reguladores:

- Comisión Federal de Comunicaciones (FCC)
- Industry Canada

FCC

Este dispositivo cumple con la 15ª parte del reglamento de la FCC. Su funcionamiento está sujeto a las siguientes dos condiciones: (1) este dispositivo no deberá causar ninguna interferencia dañina, y (2) este dispositivo deberá aceptar cualquier interferencia recibida, incluyendo aquella que podría causar un funcionamiento no deseado.

Se realizaron pruebas a este equipo cuyos resultados revelaron que cumple con los límites establecidos para un dispositivo digital de la Clase B, conforme a la 15ª parte del reglamento de la FCC. Estos límites han sido impuestos para proporcionar protección razonable contra interferencias dañinas en una instalación residencial. Este equipo genera, utiliza y puede irradiar energía de radiofrecuencia y, si no se instala y utiliza según lo que indican las instrucciones, podría causar interferencia dañina en radiocomunicaciones. Sin embargo, no hay garantía de que la interferencia no ocurrirá en determinadas instalaciones. Si este equipo efectivamente causa interferencia en la recepción de radio o televisión, la cual puede determinarse encendiendo y apagando el equipo, sugerimos al usuario que intente corregir dicha interferencia tomando una o más de las siguientes medidas:

- Volver a orientar o ubicar la antena receptora.
- Incrementar la distancia entre el equipo y el receptor.
- Conectar el equipo a una toma de corriente en un circuito distinto del circuito en el cual está conectado el receptor.
- Consultar con el distribuidor o un técnico de radio y TV con experiencia para obtener su ayuda.

¡IMPORTANTE! Todo cambio o modificación no aprobado expresamente por el fabricante podría desautorizar al usuario para operar el equipo.

Industria de Canada

Este dispositivo cumple con las normas de la Industria de Canada licencia-exenta RSS. Su funcionamiento está sujeto a las siguientes dos condiciones: (1) este dispositivo no deberá causar ninguna interferencia dañina, y (2) este dispositivo deberá aceptar cualquier interferencia, incluyendo aquella que podría causar el funcionamiento no deseado del dispositivo.

Regulatory Compliance

This product complies with standards established by the following regulatory bodies:

- Federal Communications Commission (FCC)
- Industry Canada

FCC

This device complies with Part 15 of the FCC Rules. Operation is subject to the following two conditions: (1) this device may not cause harmful interference, and (2) this device must accept any interference received, including interference that may cause undesired operation.

This equipment has been tested and found to comply with the limits for a Class B digital device, pursuant to Part 15 of the FCC Rules. These limits are designed to provide reasonable protection against harmful interference in a residential installation. This equipment generates, uses, and can radiate radio frequency energy and, if not installed and used in accordance with the instructions, may cause harmful interference to radio communications. However, there is no guarantee that interference will not occur in a particular installation. If this equipment does cause harmful interference to radio or television reception, which can be determined by turning the equipment off and on, the user is encouraged to try to correct the interference by one or more of the following measures:

- Reorient or relocate the receiving antenna.
- Increase the separation between the equipment and receiver.
- Connect the equipment into an outlet on a circuit different from that to which the receiver is connected.
- Consult the dealer or an experienced radio/TV technician for help.

IMPORTANT! Changes or modifications not expressly approved by the manufacturer could void the user's authority to operate the equipment.

Industry Canada

This device complies with Industry Canada licence-exempt RSS standard(s). Operation is subject to the following two conditions:

(1) this device may not cause interference, and (2) this device must accept any interference, including interference that may cause undesired operation of the device.

Important Safeguards

1. Read all instructions in their entirety.
2. Familiarize yourself with all warning and caution statements.
3. Remind all family members of safety precautions.
4. Always have access to your lock's standard key.
5. If using the Triple Touch Lock feature, make sure to have your smartphone, fob or standard key with you to prevent locking yourself out.
6. Familiarize yourself with all light ring error notifications.
7. Replace low batteries immediately.

Preventing Inadvertent Unlocking of Your Door

⚠ WARNING: Failure to follow these safeguards could result in your lock opening inadvertently.

1. Avoid keeping and storing phones and fobs unnecessarily close to the lock when inside the home.
2. Restrict access to your Kevo lock's back panel and routinely check your settings to ensure they have not been altered without your knowledge.
3. Protect the password to your Kevo app and web portal accounts.
4. When sending an eKey, always double-check that you are sending it to the correct recipient.
5. Protect and restrict access to your smartphone so that your app settings cannot be altered without your knowledge.
6. Enable the Kevo app's security passcode so that your app settings cannot be altered without your knowledge.
7. When sending eKeys, be aware of the difference between an Admin user and other users in the system: an Admin user can send, disable and delete eKeys.
8. If your smartphone is lost or stolen, use the Kevo web portal (www.mykevo.com) to disable it.
9. If a fob in your Kevo system is lost or stolen, reset your lock to delete it from memory.

⚠ CAUTION: As with any radio-based technology, it should be noted that the accuracy and reliability of the Kevo lock's inside-outside sensor cannot be guaranteed. Users should not rely solely on the Kevo lock's sensor for security purposes and should always use caution. This manufacturer assumes no responsibility for incorrect results or damages resulting from the use of the Kevo lock's sensor.

Certain home configurations may impede the Kevo lock's sensor more than others. Example: *Your home office is located next to your entryway, and part of the office extends past the front door, jutting into the front yard. If your device is being actively used in that office extension, the Kevo lock's sensor could possibly detect the device as being outside of your home while that device is in active use.*

⚠ WARNING: This Manufacturer advises that no lock can provide complete security by itself. This lock may be defeated by forcible or technical means, or evaded by entry elsewhere on the property. No lock can substitute for caution, awareness of your environment, and common sense. Builder's hardware is available in multiple performance grades to suit the application. In order to enhance security and reduce risk, you should consult a qualified locksmith or other security professional.

Medidas de protección importantes

1. Lea las instrucciones en su totalidad.
2. Familiarícese con todas las definiciones de advertencia y precaución.
3. Recuerde a todos los integrantes de su familia las precauciones de seguridad.
4. Siempre tenga acceso a la llave estándar de su cerradura.
5. Si utiliza la función de cierre con tres toques, verifique que lleve consigo el teléfono inteligente, llavero transmisor o llave estándar para evitar quedarse afuera.
6. Familiarícese con todas las notificaciones de error que aparecen con anillo de luz.
7. Cambie las baterías gastadas de inmediato.

Impedir la apertura involuntaria de la puerta

⚠ ADVERTENCIA: Si no se cumplen estas medidas de protección, la cerradura podría abrirse involuntariamente.

1. Evite mantener y guardar los teléfonos y llaveros transmisores cerca de la cerradura cuando esté en el interior de la casa.
2. Limite el acceso al panel posterior de la cerradura Kevo y verifique en forma rutinaria las configuraciones para comprobar que no hayan sido alteradas sin su conocimiento.
3. Proteja las contraseñas de las cuentas del portal web y aplicación Kevo.
4. Al enviar una llave electrónica, siempre vuelva a comprobar que la está enviando al destinatario correcto.
5. Proteja y limite el acceso a su teléfono inteligente para que no se puedan alterar las configuraciones de la aplicación sin su conocimiento.
6. Habilite el código de acceso de seguridad de la aplicación Kevo para que no se puedan alterar las configuraciones de la aplicación sin su conocimiento.
7. Al enviar llaves electrónicas, tenga en cuenta la diferencia entre un usuario Admin y otros usuarios del sistema: el usuario Admin puede enviar, deshabilitar y eliminar llaves electrónicas.
8. Si pierde o roban su teléfono inteligente, utilice el portal web (www.mykevo.com) para deshabilitar el dispositivo inteligente.
9. Si pierde o roban su llavero transmisor, reinicie la cerradura para eliminarla de la memoria.

⚠ PRECAUCIÓN: Al igual que con cualquier tecnología de radio, se debe tener en cuenta que la precisión, la confiabilidad o la utilidad del posicionamiento de su dispositivo no se pueden garantizar con ubicaciones derivadas del sensor correspondiente a la cerradura Kevo; esta función se brinda solo por propósitos de comodidad. Los usuarios no deben confiar únicamente en el sensor de la cerradura Kevo para propósitos de seguridad y siempre deben tener precaución. Kwikset no asume responsabilidad alguna por resultados incorrectos o daños producidos por el uso del sensor de la cerradura Kevo.

Ciertas configuraciones domésticas pueden impedir el funcionamiento del sensor de la cerradura Kevo más que otras. Ejemplo: *Su oficina está ubicada junto al recibidor, y parte de la oficina se extiende más allá de la puerta principal, proyectándose hacia el patio principal. Si su dispositivo se utiliza en forma activa en dicha extensión de la oficina, es posible que el sensor de la cerradura Kevo detecte el dispositivo en una ubicación externa al hogar mientras dicho dispositivo se encuentra en uso activo.*

⚠ ADVERTENCIA: Este Fabricante hace saber que no hay cerrojos que puedan proporcionar completa seguridad por sí mismos. Puede hacerse que falle este cerrojo forzándolo o utilizando medios técnicos, o puede evadirse entrando por otra parte de la propiedad. No hay cerrojos que puedan hacer de sustitutos para la precaución, el estar al tanto del entorno, y el sentido común. Pueden obtenerse piezas de ferretería de constructor con diversos grados de rendimiento para ajustarse a la aplicación. Para realizar la seguridad y reducir los riesgos, debe consultar con un cerrajero capacitado o otro profesional de seguridad.

Mesures de protection importantes

1. Lire toutes les instructions en entier.
2. Familiarisez-vous avec tous les avertissements et mises en garde.
3. Rappelez les précautions de sécurité à tous les membres de la famille.
4. Conservez un accès permanent à la clé standard de votre serrure.
5. Lors de l'utilisation de la fonction trois touches de la serrure, assurez-vous d'avoir avec vous votre téléphone intelligent, porte-clés électronique ou clé standard pour éviter que la porte ne se verrouille alors que vous êtes dehors.
6. Familiarisez-vous avec tous les anneaux lumineux de notification d'erreur.
7. Remplacez les piles faibles immédiatement.

Empêcher le déverrouillage involontaire de votre porte

⚠ WARNING: Failure to follow these safeguards could result in your lock opening inadvertently.

1. Évitez de garder ou entreposer des porte-clés électroniques et téléphones excessivement près de la serrure lorsque vous êtes à l'intérieur de la maison.
2. Restreignez l'accès au panneau arrière de votre serrure Kevo et vérifiez régulièrement vos réglages pour vous assurer qu'ils n'ont pas été modifiés à votre insu.
3. Protégez les mots de passe de vos comptes de portail Web et application Kevo.
4. Lors de l'envoi d'une eKey, revérifiez systématiquement que vous êtes en train de l'envoyer au bon destinataire.
5. Protégez et restreignez l'accès à votre téléphone intelligent afin que les réglages de votre application ne puissent être modifiés à votre insu.
6. Activez le code d'accès de sécurité de l'application Kevo afin que les réglages de votre application ne puissent être modifiés à votre insu.
7. Lors de l'envoi d'eKeys, tenez compte de la différence entre un utilisateur Administrateur et d'autres utilisateurs du système ; un utilisateur Administrateur peut envoyer, désactiver et supprimer des eKeys.
8. Si votre téléphone est perdu ou volé, utilisez le portail Web (www.mykevo.com) pour le supprimer ou le désactiver.
9. Si votre porte-clés électronique est perdu ou volé, réinitialisez votre serrure pour l'effacer de la mémoire.

⚠ ATTENTION: Comme pour une technologie radio, il est à noter que la précision, la fiabilité ou l'utilisabilité du positionnement de votre appareil indiqué par le capteur intérieur-extérieur de la serrure Kevo ne peuvent être garanties; ces données sont fournies à titre de commodité uniquement. Les utilisateurs ne doivent pas se fier exclusivement aux capteurs de la serrure Kevo à des fins de sécurité et ils doivent toujours faire preuve de prudence. Le fabricant se dégage de toute responsabilité en cas de résultats incorrects ou de dommages découlant de l'utilisation du capteur de la serrure Kevo.

Certaines configurations de maisons peuvent entraver plus que d'autres le capteur de la serrure Kevo. Exemple: *Votre bureau à la maison est situé à côté de votre entrée, et une partie du bureau s'étend au-delà de la porte de la façade, s'avancant sur la cour d'entrée. Si votre appareil est en train d'être utilisé activement dans cette extension de bureau, le capteur de la serrure Kevo pourrait éventuellement détecter l'appareil comme étant à l'extérieur de votre maison alors que cet appareil est en utilisation active.*

⚠ AVERTISSEMENT: Le fabricant tient à vous aviser qu'aucun verrou ne peut à lui seul offrir une sécurité complète. Ce verrou peut être mis hors d'état par la force ou des moyens techniques ou être évité par l'utilisation d'une autre entrée dans la propriété. Aucun verrou ne peut remplacer la surveillance de votre environnement et le bon sens. Différentes qualités de matériel d'installation sont offertes pour différentes applications. Afin d'augmenter la sécurité et de réduire le risque, vous devriez consulter un serrurier qualifié ou un autre professionnel de la sécurité.