

PROPRIETARY INFORMATION
 ALL RIGHTS RESERVED. NO PARTS OF THIS DOCUMENT MAY BE REPRODUCED, STORED IN A RETRIEVAL SYSTEM, OR TRANSMITTED, IN ANY FORM OR BY ANY MEANS, ELECTRONIC, MECHANICAL, PHOTOCOPYING, RECORDING OR OTHERWISE, WITHOUT THE PRIOR WRITTEN PERMISSION OF TADIRAN TELEMATICS LTD. NOR USED IN WHOLE OR IN PART FOR ANY PURPOSE OR FOR ANY CUSTOMER EXCEPT TADIRAN TELEMATICS.

REV	Δ	DESCRIPTION	CHNGD SHEET	E.C.N	DATE	DRAWN	CHECKED
<Rev>	<D>	<Description>	<Chngd>	<ECN>	<Date>	<Drawn>	<Checked>

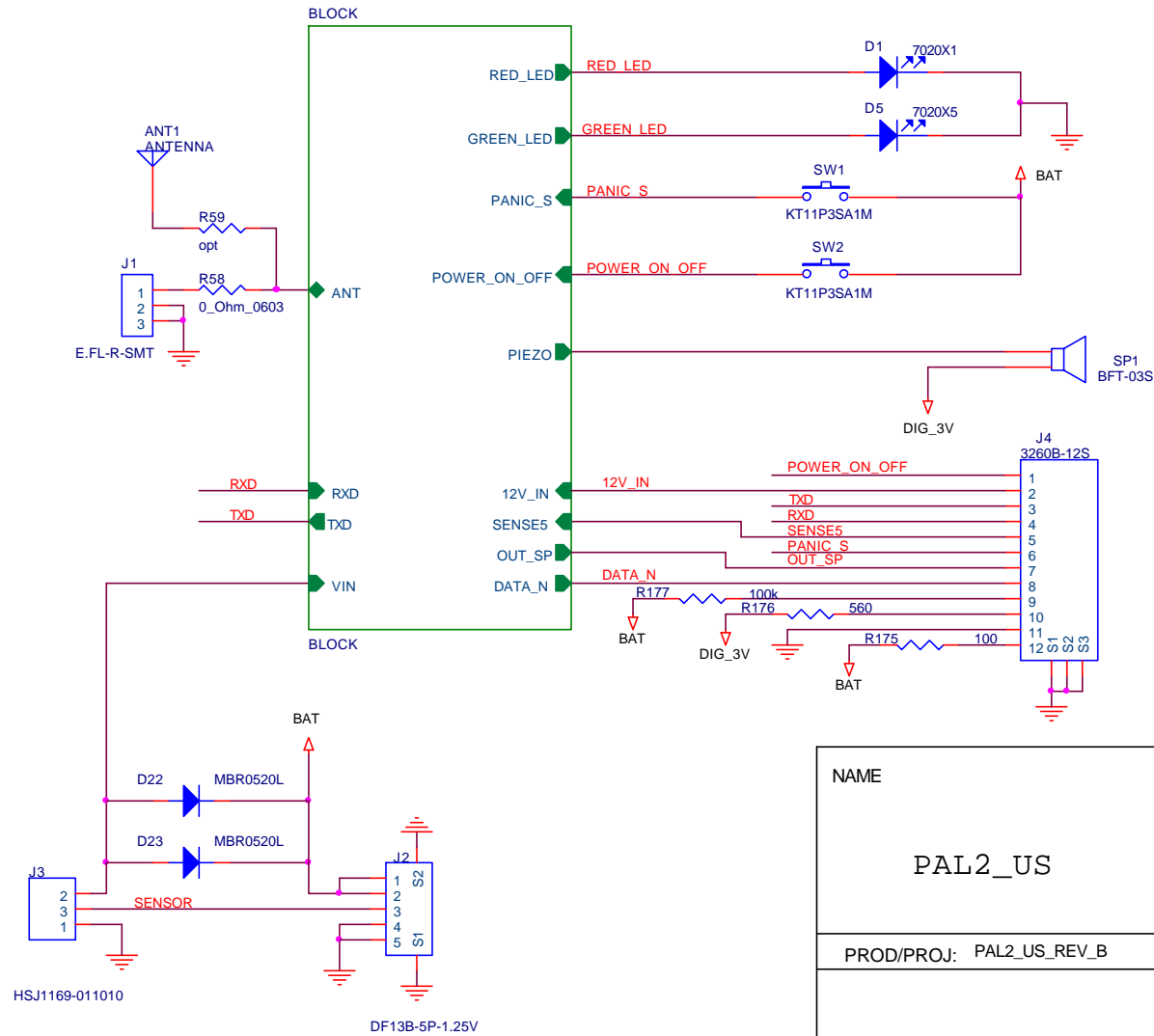

PROPRIETARY INFORMATION
 ALL RIGHTS RESERVED. NO PARTS OF THIS DOCUMENT MAY BE REPRODUCED, STORED IN A RETRIEVAL SYSTEM, OR TRANSMITTED, IN ANY FORM OR BY ANY MEANS, ELECTRONIC, MECHANICAL, PHOTOCOPYING, RECORDING OR OTHERWISE, WITHOUT THE PRIOR WRITTEN PERMISSION OF TADIRAN TELEMATICS LTD. NOR USED IN WHOLE OR IN PART FOR ANY PURPOSE OR FOR ANY CUSTOMER EXCEPT TADIRAN TELEMATICS.

NAME	PROCESSING LEVEL		DESIGNED	<lnit1>	<Date1>	SHEET/OF
	OPERATION	CATALOG NO.				
PAL2_US	<Op1>	<CatNO1>	APPROVED	<lnit3>	<Date3>	1 / 14
	<Op2>	<CatNO2>				
	<Op3>	<CatNO3>				
	<Op4>	<CatNO4>				
	<Op5>	<CatNO5>				
PROD/PROJ: PAL2_US_REV_B		Q.A.	<lnit4>	<Date4>		
2 1 3 5 X X X X X 0 0						SIZE A4

AFTER RENAME

PROPRIETARY INFORMATION
 ALL RIGHTS RESERVED. NO PARTS OF THIS DOCUMENT MAY BE REPRODUCED, STORED IN A RETRIEVAL SYSTEM, OR TRANSMITTED, IN ANY FORM OR BY ANY MEANS, ELECTRONIC, MECHANICAL, PHOTOCOPYING, RECORDING OR OTHERWISE, WITHOUT THE PRIOR WRITTEN PERMISSION OF TADIRAN TELEMATICS LTD. NOR USED IN WHOLE OR IN PART FOR ANY PURPOSE OR FOR ANY CUSTOMER EXCEPT TADIRAN TELEMATICS.

REV	Δ	DESCRIPTION	CHNGD SHEET	E. C. N	DATE	DRAWN	CHECKED
<Rev>	<D>	<Description>	<Chngd>	<ECN>	<Date>	<Drawn>	<Checked>

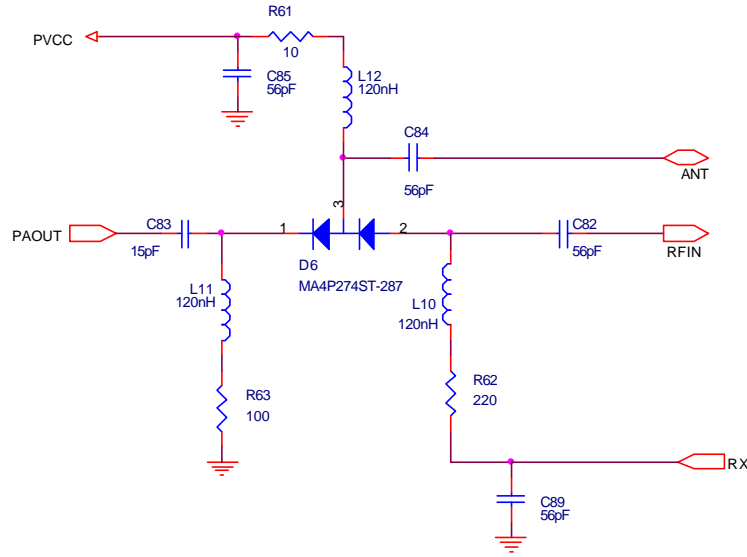

PROPRIETARY INFORMATION
 ALL RIGHTS RESERVED. NO PARTS OF THIS DOCUMENT MAY BE REPRODUCED, STORED IN A RETRIEVAL SYSTEM, OR TRANSMITTED, IN ANY FORM OR BY ANY MEANS, ELECTRONIC, MECHANICAL, PHOTOCOPYING, RECORDING OR OTHERWISE, WITHOUT THE PRIOR WRITTEN PERMISSION OF TADIRAN TELEMATICS LTD. NOR USED IN WHOLE OR IN PART FOR ANY PURPOSE OR FOR ANY CUSTOMER EXCEPT TADIRAN TELEMATICS.

NAME	PROCESSING LEVEL		SHEET OF
	OPERATION	CATALOG NO.	
ANTSW			
Monday, June 19, 2000			
PROD/PROJ: PAL2_US_A	DESIGNED		2 / 14
	CHECKED		
	APPROVED		
	Q.A.		
			SIZE A4

PROPRIETARY INFORMATION
 ALL RIGHTS RESERVED. NO PARTS OF THIS DOCUMENT
 MAY BE REPRODUCED, STORED IN A RETRIEVAL
 SYSTEM, OR TRANSMITTED, IN ANY FORM OR BY ANY
 MEANS, ELECTRONIC, MECHANICAL, PHOTOCOPIING,
 RECORDING OR OTHERWISE, WITHOUT THE PRIOR
 WRITTEN PERMISSION OF TADRAN TELEMATICS LTD.
 NOR USED IN WHOLE OR IN PART FOR ANY PURPOSE
 FOR ANY CUSTOMER EXCEPT TADRAN TELEMATICS.

PROPRIETARY INFORMATION
 ALL RIGHTS RESERVED. NO PARTS OF THIS DOCUMENT
 MAY BE REPRODUCED, STORED IN A RETRIEVAL
 SYSTEM, OR TRANSMITTED, IN ANY FORM OR BY ANY
 MEANS, ELECTRONIC, MECHANICAL, PHOTOCOPIING,
 RECORDING OR OTHERWISE, WITHOUT THE PRIOR
 WRITTEN PERMISSION OF TADRAN TELEMATICS LTD.
 NOR USED IN WHOLE OR IN PART FOR ANY PURPOSE
 FOR ANY CUSTOMER EXCEPT TADRAN TELEMATICS.

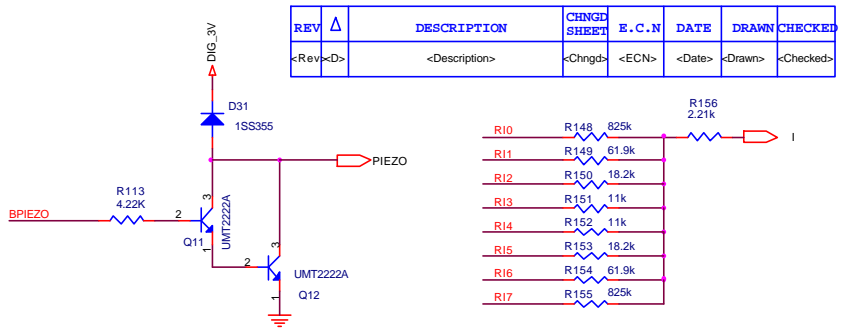
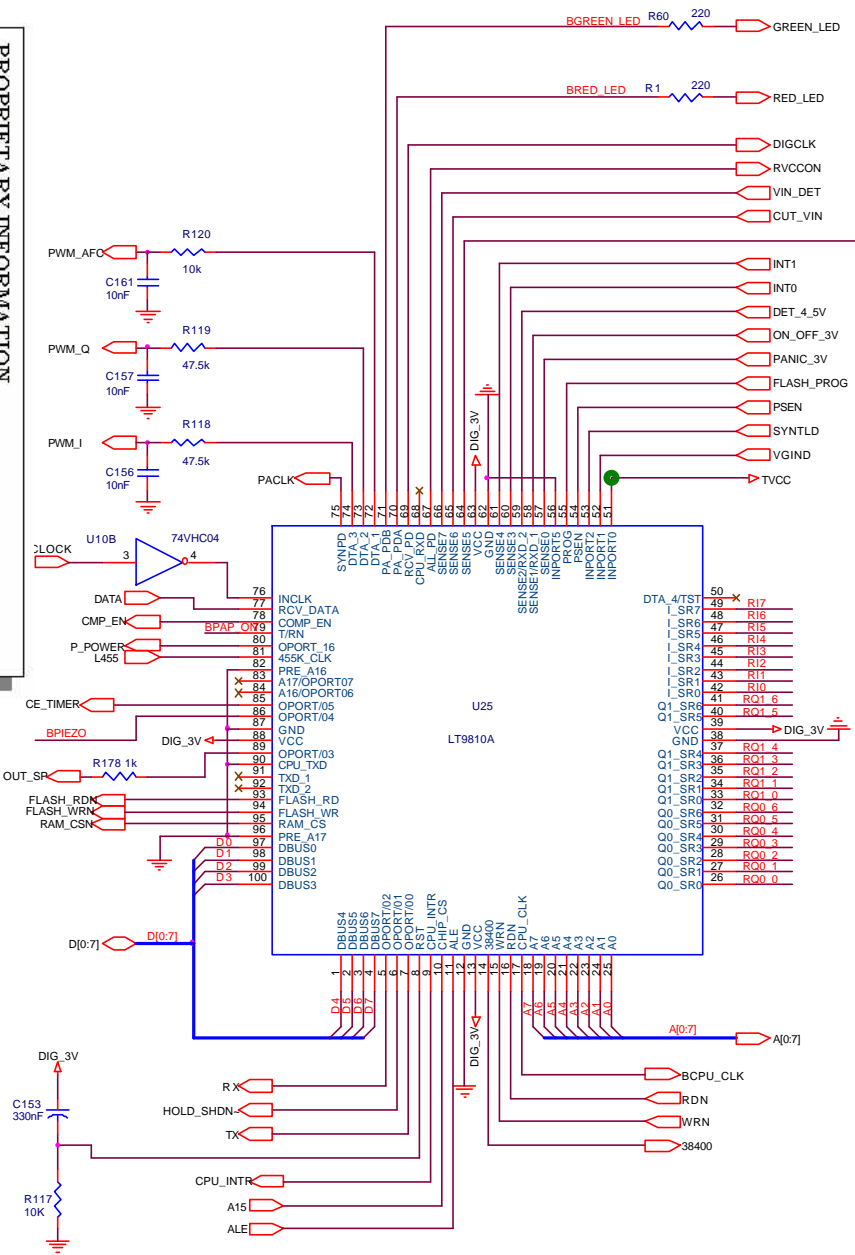

R10	R148	82.5k	R156	2.21k
R11	R149	81.9k		
R12	R150	18.2k		
R13	R151	11k		
R14	R152	11k		
R15	R153	18.2k		
R16	R154	81.9k		
R17	R155	82.5k		
RQ0_0	R134	82.5k		
RQ0_1	R135	22.1k		
RQ0_2	R136	12.1k		
RQ0_3	R137	10k		
RQ0_4	R138	12.1k		
RQ0_5	R139	22.1k		
RQ0_6	R140	82.5k		
RQ1_0	R141	82.5k		
RQ1_1	R142	22.1k		
RQ1_2	R143	12.1k		
RQ1_3	R144	10k		
RQ1_4	R145	12.1k		
RQ1_5	R146	22.1k		
RQ1_6	R147	82.5k		

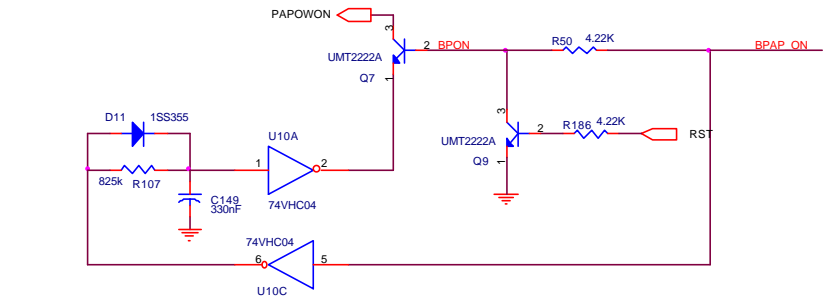
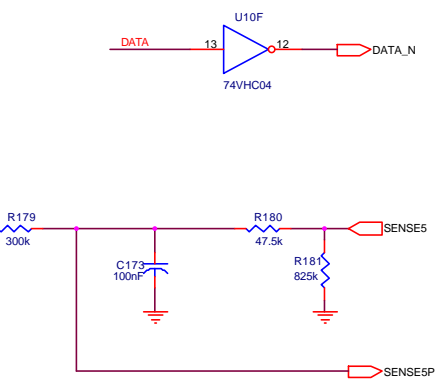

NAME	ASIC	PROCESSING LEVEL	
		OPERATION	CATALOG NO.
	PAL_IL_F		
	Sunday, July 30, 2000		
PROD/PROJ:		DESIGNED	SHEET/OF
		CHECKED	
		APPROVED	3 / 14
		Q.A.	SIZE
			A3

PROPRIETARY INFORMATION
 ALL RIGHTS RESERVED. NO PARTS OF THIS DOCUMENT MAY BE REPRODUCED, STORED IN A RETRIEVAL SYSTEM, OR TRANSMITTED, IN ANY FORM OR BY ANY MEANS, ELECTRONIC, MECHANICAL, PHOTOCOPIING, RECORDING OR OTHERWISE, WITHOUT THE PRIOR WRITTEN PERMISSION OF TADIRAN TELEMATICS LTD. NOR USED IN WHOLE OR IN PART FOR ANY PURPOSE OR FOR ANY CUSTOMER EXCEPT TADIRAN TELEMATICS.

REV	Δ	DESCRIPTION	CHNGD SHEET	E. C. N	DATE	DRAWN	CHECKED
<Rev><D>		<Description>	<Chngd>	<ECN>	<Date>	<Drawn>	<Checked>

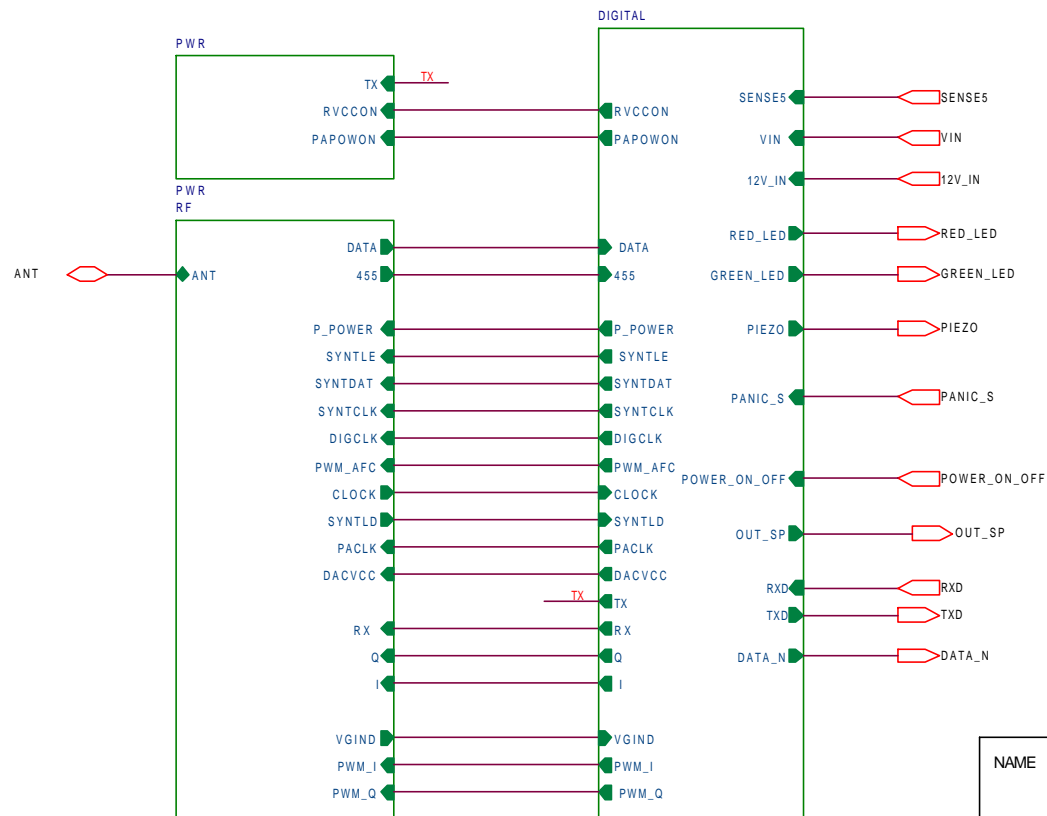

PROPRIETARY INFORMATION
 ALL RIGHTS RESERVED. NO PARTS OF THIS DOCUMENT MAY BE REPRODUCED, STORED IN A RETRIEVAL SYSTEM, OR TRANSMITTED, IN ANY FORM OR BY ANY MEANS, ELECTRONIC, MECHANICAL, PHOTOCOPIING, RECORDING OR OTHERWISE, WITHOUT THE PRIOR WRITTEN PERMISSION OF TADIRAN TELEMATICS LTD. NOR USED IN WHOLE OR IN PART FOR ANY PURPOSE OR FOR ANY CUSTOMER EXCEPT TADIRAN TELEMATICS.

NAME	BLOCK	PROCESSING LEVEL	
		OPERATION	CATALOG NO.
	PAL_IL_F		
Wednesday, June 21, 2000			
PROD/PROJ:		DESIGNED	
		CHECKED	
		APPROVED	
		Q.A.	
			SHEET/OF
			4 / 14
			SIZE B

PROPRIETARY INFORMATION
 ALL RIGHTS RESERVED. NO PARTS OF THIS DOCUMENT
 MAY BE REPRODUCED, STORED IN A RETRIEVAL
 SYSTEM, OR TRANSMITTED, IN ANY FORM OR BY ANY
 MEANS, ELECTRONIC, MECHANICAL, PHOTOCOPIING,
 RECORDING OR OTHERWISE, WITHOUT THE PRIOR
 WRITTEN PERMISSION OF TADIRAN TELEMATICS LTD,
 NOR USED IN WHOLE OR IN PART FOR ANY PURPOSE OR
 FOR ANY CUSTOMER EXCEPT TADIRAN TELEMATICS.

REV	DESCRIPTION	CHNGD SHEET	E. C. N	DATE	DRAWN	CHECKED
<Rev> <D>	<Description>	<Chngd>	<ECN>	<Date>	<Drawn>	<Checked>

PROPRIETARY INFORMATION
 ALL RIGHTS RESERVED. NO PARTS OF THIS DOCUMENT
 MAY BE REPRODUCED, STORED IN A RETRIEVAL
 SYSTEM, OR TRANSMITTED, IN ANY FORM OR BY ANY
 MEANS, ELECTRONIC, MECHANICAL, PHOTOCOPIING,
 RECORDING OR OTHERWISE, WITHOUT THE PRIOR
 WRITTEN PERMISSION OF TADIRAN TELEMATICS LTD,
 NOR USED IN WHOLE OR IN PART FOR ANY PURPOSE OR
 FOR ANY CUSTOMER EXCEPT TADIRAN TELEMATICS.

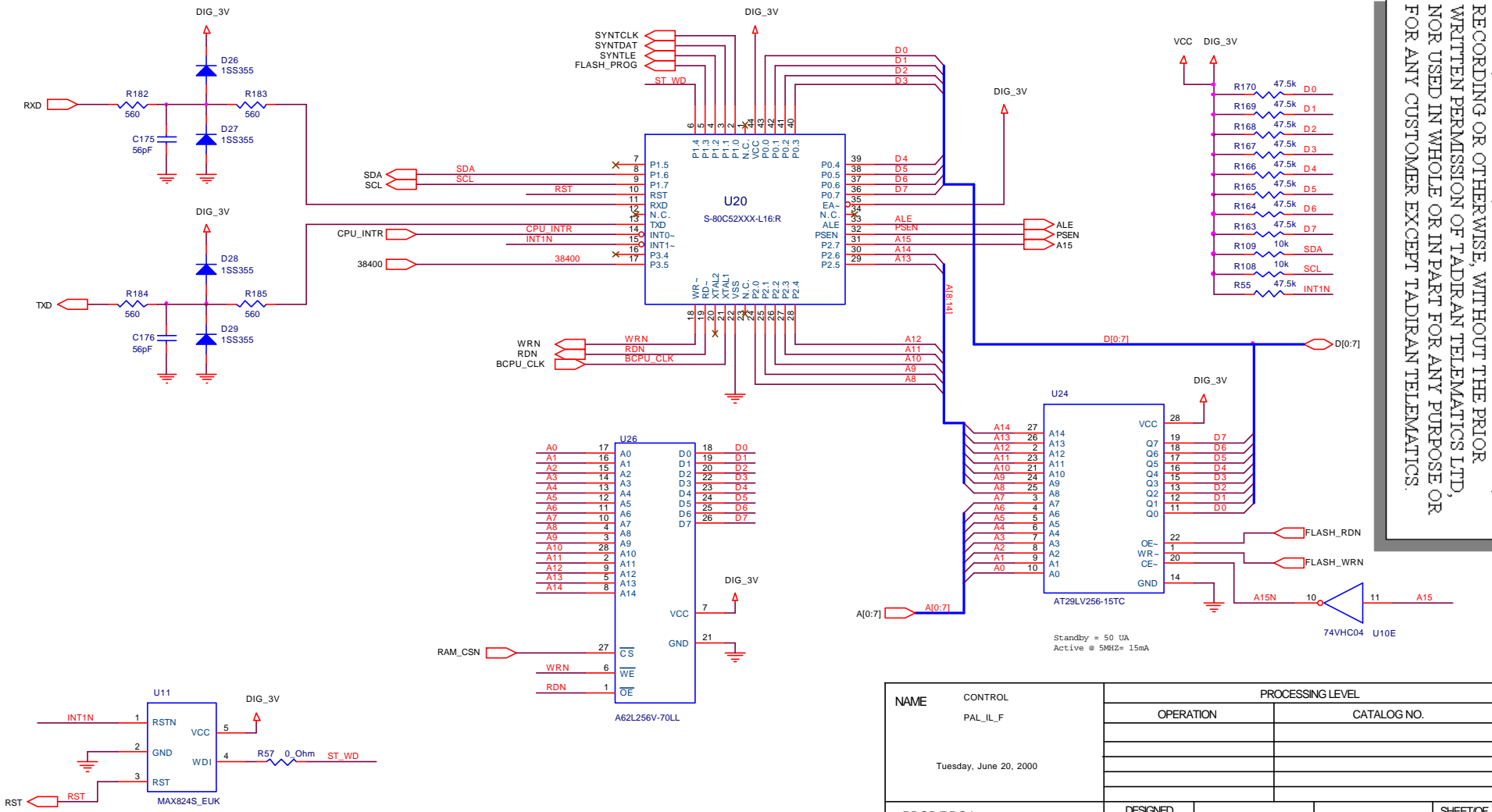

Standby = 50 UA
 Active @ 5MHz = 15mA

NAME	CONTROL	PROCESSING LEVEL	
		OPERATION	CATALOG NO.
	PAL_ILF		
Tuesday, June 20, 2000			
PROD/PROJ:		DESIGNED	SHEET/OF
		CHECKED	5 / 14
		APPROVED	
		Q.A.	SIZE
			B

SUPPLY CURRENT = 12UA

PROPRIETARY INFORMATION
 ALL RIGHTS RESERVED. NO PARTS OF THIS DOCUMENT
 MAY BE REPRODUCED, STORED IN A RETRIEVAL
 SYSTEM, OR TRANSMITTED, IN ANY FORM OR BY ANY
 MEANS, ELECTRONIC, MECHANICAL, PHOTOCOPIING,
 RECORDING OR OTHERWISE, WITHOUT THE PRIOR
 WRITTEN PERMISSION OF TADIRAN TELEMATICS LTD.
 NOR USED IN WHOLE OR IN PART FOR ANY PURPOSE OR
 FOR ANY CUSTOMER EXCEPT TADIRAN TELEMATICS.

REV	Δ	DESCRIPTION	CHNGD SHEET	E. C. N	DATE	DRAWN	CHECKED
<Rev>	<D>	<Description>	<Chngd>	<ECN>	<Date>	<Drawn>	<Checked>

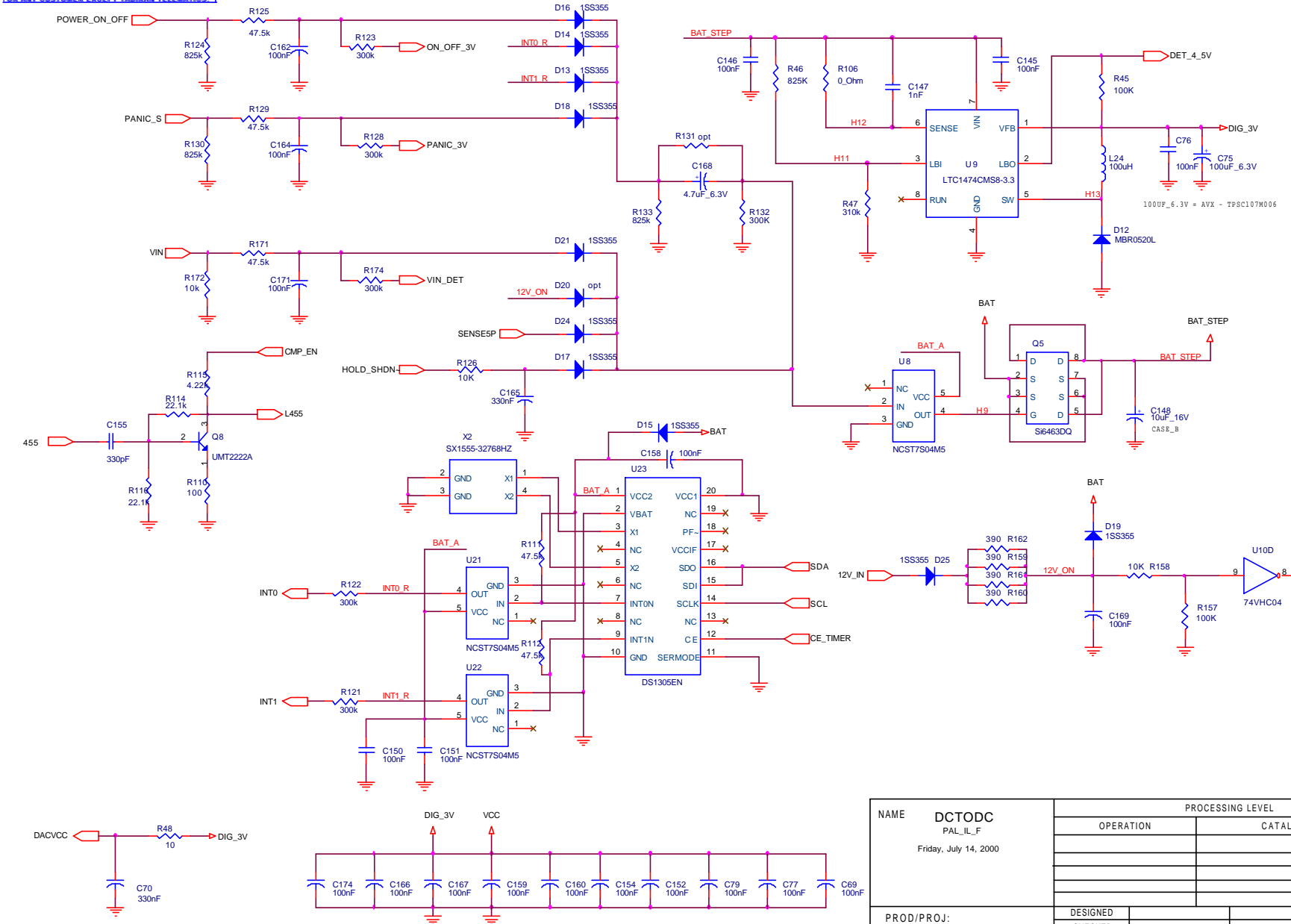

PROPRIETARY INFORMATION
 ALL RIGHTS RESERVED. NO PARTS OF THIS DOCUMENT
 MAY BE REPRODUCED, STORED IN A RETRIEVAL
 SYSTEM, OR TRANSMITTED, IN ANY FORM OR BY ANY
 MEANS, ELECTRONIC, MECHANICAL, PHOTOCOPIING,
 RECORDING OR OTHERWISE, WITHOUT THE PRIOR
 WRITTEN PERMISSION OF TADIRAN TELEMATICS LTD.
 NOR USED IN WHOLE OR IN PART FOR ANY PURPOSE OR
 FOR ANY CUSTOMER EXCEPT TADIRAN TELEMATICS.

NAME	DCTODC		PROCESSING LEVEL	
	PAL_IL_F		OPERATION	CATALOG NO.
	Friday, July 14, 2000			
PROD/PROJ:				SHEET/OF
	DESIGNED			/
	CHECKED			
	APPROVED			
	Q. A.			SIZE
				A4

PROPRIETARY INFORMATION
 ALL RIGHTS RESERVED. NO PARTS OF THIS DOCUMENT
 MAY BE REPRODUCED, STORED IN A RETRIEVAL
 SYSTEM, OR TRANSMITTED, IN ANY FORM OR BY ANY
 MEANS, ELECTRONIC, MECHANICAL PHOTOCOPYING,
 RECORDING OR OTHERWISE, WITHOUT THE PRIOR
 WRITTEN PERMISSION OF TADIRAN TELEMATICS LTD.
 NOR USED IN WHOLE OR IN PART FOR ANY PURPOSE OR
 FOR ANY CUSTOMER EXCEPT TADIRAN TELEMATICS.

REV	Δ	DESCRIPTION	CHNGD SHEET	E. C. N	DATE	DRAWN	CHECKED
<Rev>	<D>	<Description>	<Chngd>	<ECN>	<Date>	<Drawn>	<Checked>

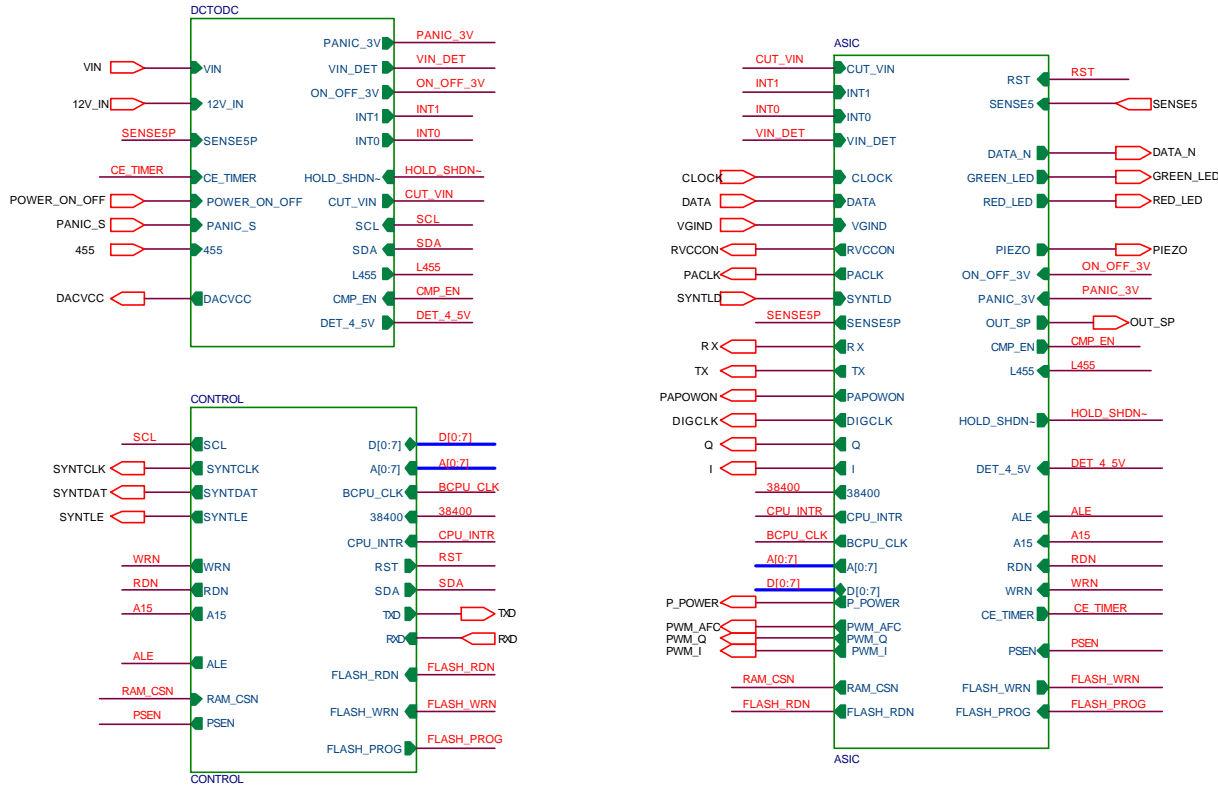

PROPRIETARY INFORMATION
 ALL RIGHTS RESERVED, NO PARTS OF THIS DOCUMENT
 MAY BE REPRODUCED, STORED IN A RETRIEVAL
 SYSTEM, OR TRANSMITTED, IN ANY FORM OR BY ANY
 MEANS, ELECTRONIC, MECHANICAL, PHOTOCOPYING,
 RECORDING OR OTHERWISE, WITHOUT THE PRIOR
 WRITTEN PERMISSION OF TADIRAN TELEMATICS LTD,
 NOR USED IN WHOLE OR IN PART FOR ANY PURPOSE OR
 FOR ANY CUSTOMER EXCEPT TADIRAN TELEMATICS.

NAME	DIGITAL	PROCESSING LEVEL	
		OPERATION	CATALOG NO.
PAL_IL_F			
Wednesday, June 21, 2000			
PROD/PROJ:	DESIGNED		SHEET/OF 7 / 14
	CHECKED		
	APPROVED		
	Q. A.		
			SIZE A3

PROPRIETARY INFORMATION
 ALL RIGHTS RESERVED. NO PARTS OF THIS DOCUMENT
 MAY BE REPRODUCED, STORED IN A RETRIEVAL
 SYSTEM, OR TRANSMITTED, IN ANY FORM OR BY ANY
 MEANS, ELECTRONIC, MECHANICAL, PHOTOCOPIING,
 RECORDING OR OTHERWISE, WITHOUT THE PRIOR
 WRITTEN PERMISSION OF TADIRAN TELEMATICS LTD.
 NOR USED IN WHOLE OR IN PART FOR ANY PURPOSE
 FOR ANY CUSTOMER EXCEPT TADIRAN TELEMATICS.

REV	Δ	DESCRIPTION	CHNGD SHEET	E. C. N	DATE	DRAWN	CHECKED
<Rev>	<D>	<Description>	<Chngd>	<ECN>	<Date>	<Drawn>	<Checked>

PROPRIETARY INFORMATION
 ALL RIGHTS RESERVED, NO PARTS OF THIS DOCUMENT
 MAY BE REPRODUCED, STORED IN A RETRIEVAL
 SYSTEM, OR TRANSMITTED, IN ANY FORM OR BY ANY
 MEANS, ELECTRONIC, MECHANICAL, PHOTOCOPIING,
 RECORDING OR OTHERWISE, WITHOUT THE PRIOR
 WRITTEN PERMISSION OF TADIRAN TELEMATICS LTD.
 NOR USED IN WHOLE OR IN PART FOR ANY PURPOSE OR
 FOR ANY CUSTOMER EXCEPT TADIRAN TELEMATICS.

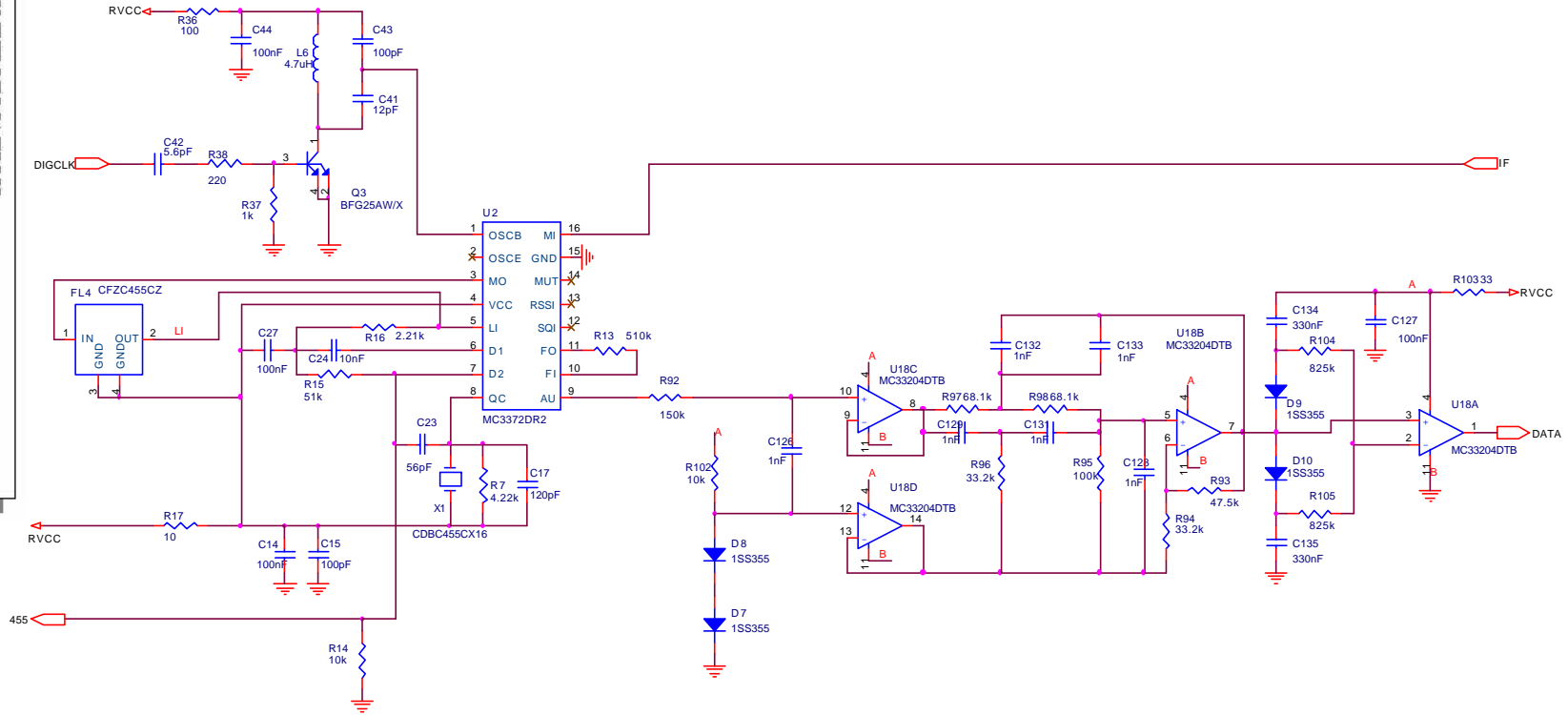

NAME	PROCESSING LEVEL		SHEET/OF
	OPERATION	CATALOG NO.	
Monday, June 19, 2000			
PROD/PROJ: PAL2 US A	DESIGNED		8 / 14
	CHECKED		
	APPROVED		
	Q.A.		
			SIZE A3

PROPRIETARY INFORMATION
 ALL RIGHTS RESERVED. NO PARTS OF THIS DOCUMENT
 MAY BE REPRODUCED, STORED IN A RETRIEVAL
 SYSTEM, OR TRANSMITTED, IN ANY FORM OR BY ANY
 MEANS, ELECTRONIC, MECHANICAL, PHOTOCOPYING,
 RECORDING OR OTHERWISE, WITHOUT THE PRIOR
 WRITTEN PERMISSION OF TADIRAN TELEMATICS LTD.
 NOR USED IN WHOLE OR IN PART FOR ANY PURPOSE OR
 FOR ANY CUSTOMER EXCEPT TADIRAN TELEMATICS.

REV	Δ	DESCRIPTION	CHNGD SHEET	E. C. N	DATE	DRAWN	CHECKED
<Rev>	<D>	<Description>	<Chngd>	<ECN>	<Date>	<Drawn>	<Checked>

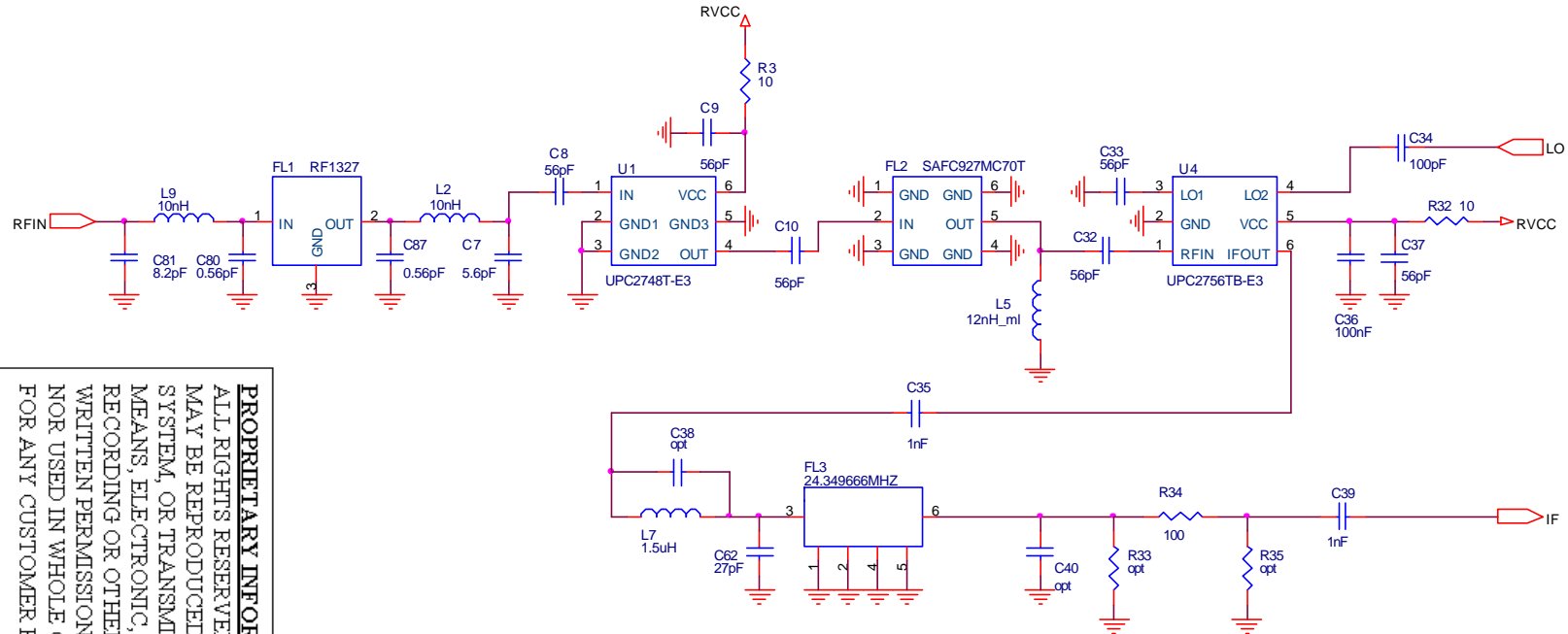

PROPRIETARY INFORMATION
 ALL RIGHTS RESERVED, NO PARTS OF THIS DOCUMENT
 MAY BE REPRODUCED, STORED IN A RETRIEVAL
 SYSTEM, OR TRANSMITTED, IN ANY FORM OR BY ANY
 MEANS, ELECTRONIC, MECHANICAL, PHOTOCOPYING,
 RECORDING OR OTHERWISE, WITHOUT THE PRIOR
 WRITTEN PERMISSION OF TADIRAN TELEMATICS LTD.
 NOR USED IN WHOLE OR IN PART FOR ANY PURPOSE OR
 FOR ANY CUSTOMER EXCEPT TADIRAN TELEMATICS.

NAME	PROCESSING LEVEL	
	OPERATION	CATALOG NO.
LNA_MIX		
Monday, June 19, 2000		
PROD/PROJ: PAL2 US A	DESIGNED	
	CHECKED	
	APPROVED	
	Q.A.	
		SHEET OF
		9 / 14
		SIZE
		A4

PROPRIETARY INFORMATION
 ALL RIGHTS RESERVED, NO PARTS OF THIS DOCUMENT
 MAY BE REPRODUCED, STORED IN A RETRIEVAL
 SYSTEM, OR TRANSMITTED IN ANY FORM OR BY ANY
 MEANS, ELECTRONIC, MECHANICAL, PHOTOCOPIING,
 RECORDING OR OTHERWISE, WITHOUT THE PRIOR
 WRITTEN PERMISSION OF TADIRAN TELEMATICS LTD.
 NOR USED IN WHOLE OR IN PART FOR ANY PURPOSE
 OR FOR ANY CUSTOMER EXCEPT TADIRAN TELEMATICS.

REV	Δ	DESCRIPTION	CHNGD SHEET	E. C. N	DATE	DRAWN	CHECKED
<Rev>	<D>	<Description>	<Chngd>	<ECN>	<Date>	<Drawn>	<Checked>

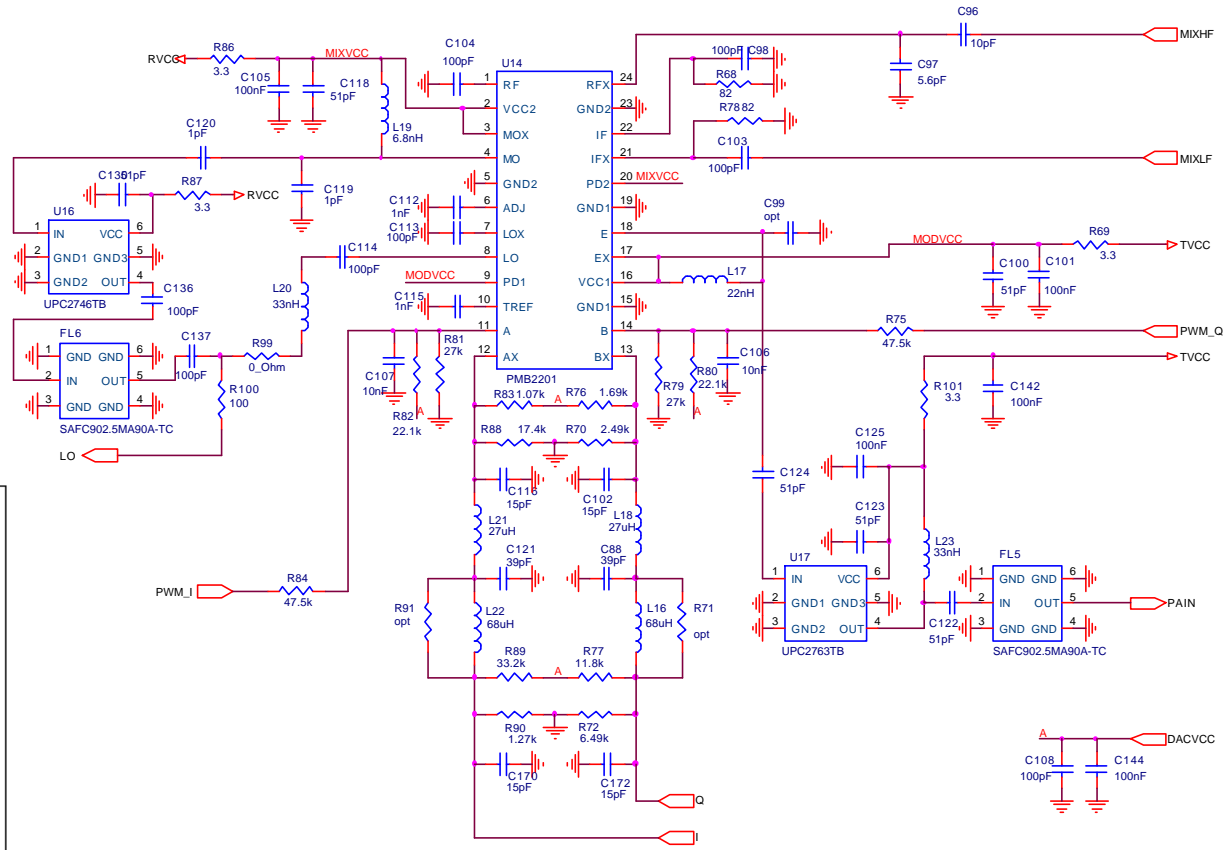

PROPRIETARY INFORMATION
 ALL RIGHTS RESERVED, NO PARTS OF THIS DOCUMENT
 MAY BE REPRODUCED, STORED IN A RETRIEVAL
 SYSTEM, OR TRANSMITTED IN ANY FORM OR BY ANY
 MEANS, ELECTRONIC, MECHANICAL, PHOTOCOPIING,
 RECORDING OR OTHERWISE, WITHOUT THE PRIOR
 WRITTEN PERMISSION OF TADIRAN TELEMATICS LTD.
 NOR USED IN WHOLE OR IN PART FOR ANY PURPOSE
 OR FOR ANY CUSTOMER EXCEPT TADIRAN TELEMATICS.

NAME	MOD	PROCESSING LEVEL		SHEET OF
		OPERATION	CATALOG NO.	
Monday, June 19, 2000				10 / 14
PROD/PROJ. PAL2 US A		DESIGNED		SIZE A3
		CHECKED		
		APPROVED		
		Q.A.		

PROPRIETARY INFORMATION
 ALL RIGHTS RESERVED, NO PARTS OF THIS DOCUMENT
 MAY BE REPRODUCED, STORED IN A RETRIEVAL
 SYSTEM, OR TRANSMITTED, IN ANY FORM OR BY ANY
 MEANS, ELECTRONIC, MECHANICAL PHOTOCOPIING,
 RECORDING OR OTHERWISE, WITHOUT THE PRIOR
 WRITTEN PERMISSION OF TADIRAN TELEMATICS LTD.
 NOR USED IN WHOLE OR IN PART FOR ANY PURPOSE OR
 FOR ANY CUSTOMER EXCEPT TADIRAN TELEMATICS.

REV	△	DESCRIPTION	CHNGD SHEET	E. C. N	DATE	DRAWN	CHECKED
<Rev>	<D>	<Description>	<Chngd>	<ECN>	<Date>	<Drawn>	<Checked>

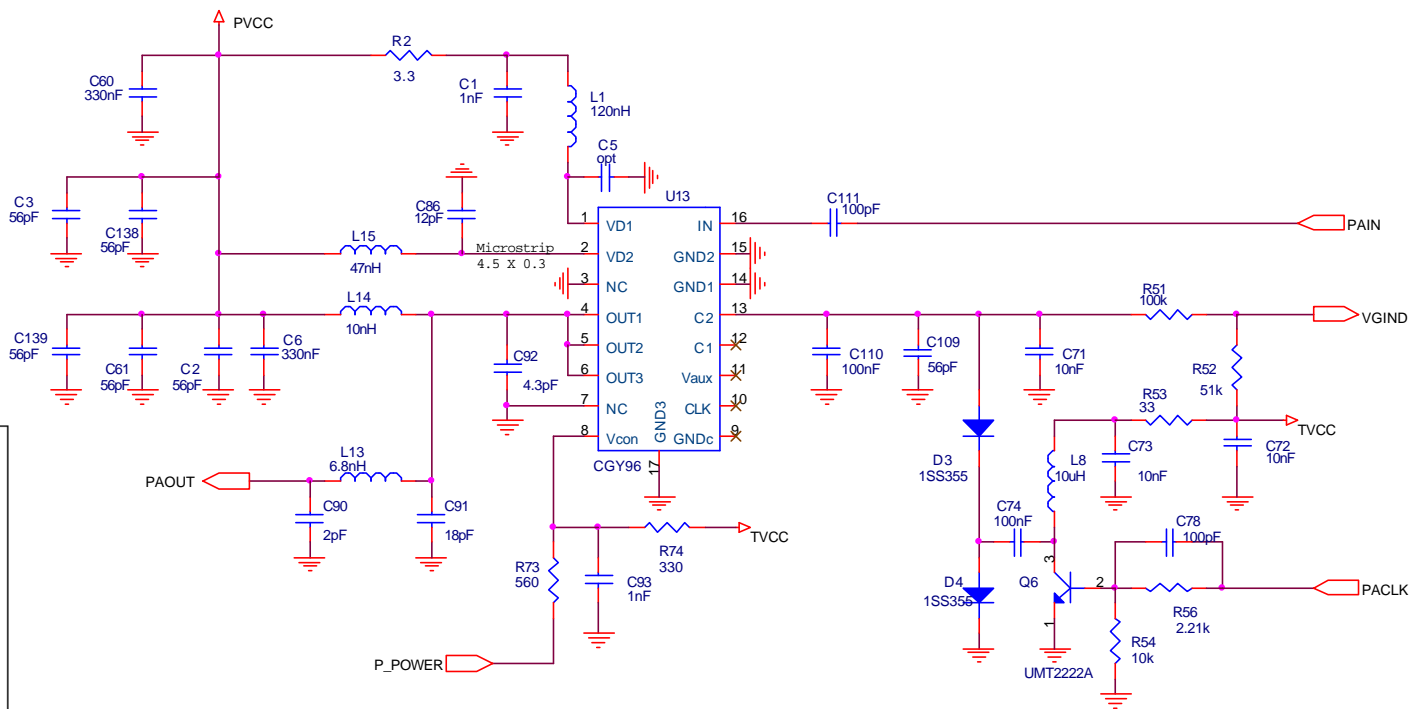

PROPRIETARY INFORMATION
 ALL RIGHTS RESERVED, NO PARTS OF THIS DOCUMENT
 MAY BE REPRODUCED, STORED IN A RETRIEVAL
 SYSTEM, OR TRANSMITTED, IN ANY FORM OR BY ANY
 MEANS, ELECTRONIC, MECHANICAL PHOTOCOPIING,
 RECORDING OR OTHERWISE, WITHOUT THE PRIOR
 WRITTEN PERMISSION OF TADIRAN TELEMATICS LTD.
 NOR USED IN WHOLE OR IN PART FOR ANY PURPOSE OR
 FOR ANY CUSTOMER EXCEPT TADIRAN TELEMATICS.

NAME PA Monday, July 03, 2000	PROCESSING LEVEL	
	OPERATION	CATALOG NO.
PROD/PROJ: PAL2_US_A	DESIGNED	SHEET OF 11 / 14
	CHECKED	
	APPROVED	
	Q.A.	
		A4 SIZE

PROPRIETARY INFORMATION
 ALL RIGHTS RESERVED, NO PARTS OF THIS DOCUMENT
 MAY BE REPRODUCED, STORED IN A RETRIEVAL
 SYSTEM, OR TRANSMITTED, IN ANY FORM OR BY ANY
 MEANS, ELECTRONIC, MECHANICAL, PHOTOCOPIING,
 RECORDING OR OTHERWISE, WITHOUT THE PRIOR
 WRITTEN PERMISSION OF TADIRAN TELEMATICS LTD,
 NOR USED IN WHOLE OR IN PART FOR ANY PURPOSE OR
 FOR ANY CUSTOMER EXCEPT TADIRAN TELEMATICS.

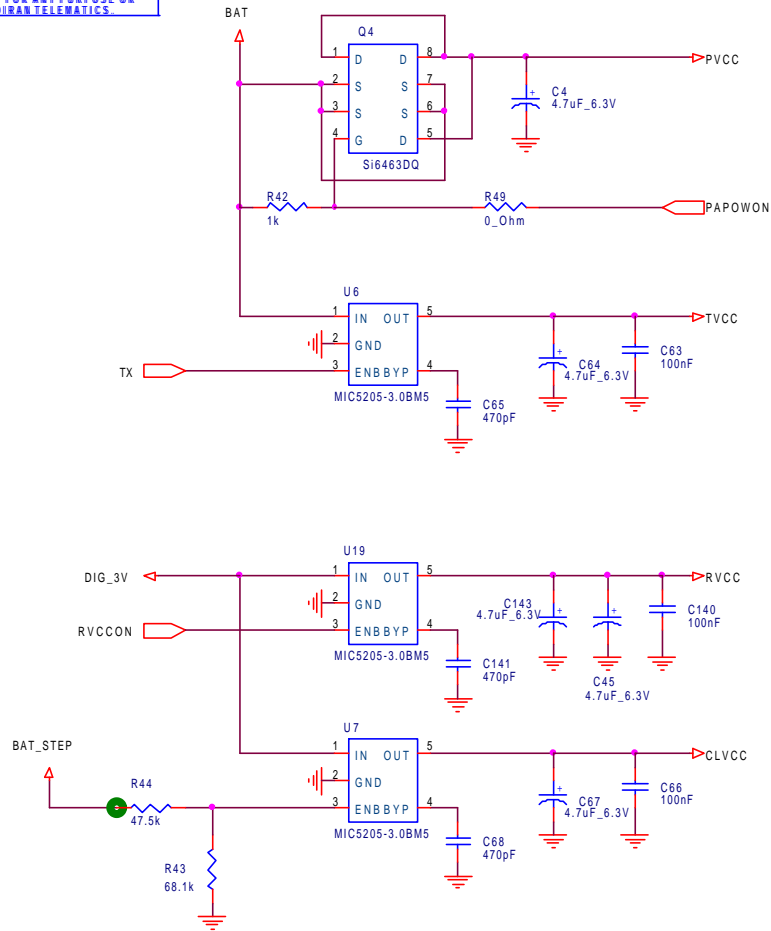

REV	Δ	DESCRIPTION	CHNGD SHEET	E. C. N	DATE	DRAWN	CHECKED
<Rev>	<D>	<Description>	<Chngd>	<ECN>	<Date>	<Drawn>	<Checked>

PROPRIETARY INFORMATION
 ALL RIGHTS RESERVED, NO PARTS OF THIS DOCUMENT
 MAY BE REPRODUCED, STORED IN A RETRIEVAL
 SYSTEM, OR TRANSMITTED, IN ANY FORM OR BY ANY
 MEANS, ELECTRONIC, MECHANICAL, PHOTOCOPIING,
 RECORDING OR OTHERWISE, WITHOUT THE PRIOR
 WRITTEN PERMISSION OF TADIRAN TELEMATICS LTD,
 NOR USED IN WHOLE OR IN PART FOR ANY PURPOSE OR
 FOR ANY CUSTOMER EXCEPT TADIRAN TELEMATICS.

NAME	PROCESSING LEVEL			
	OPERATION		CATALOG NO.	
	<Op1>		<CatNO1>	
	<Op2>		<CatNO2>	
	<Op3>		<CatNO3>	
	<Op4>		<CatNO4>	
<Op5>		<CatNO5>		
PROD/PROJ: PAL2 US A	DESIGNED	<Init1>	<Date1>	SHEET/OF 12/14 SIZE B
	CHECKED	<Init2>	<Date2>	
	APPROVED	<Init3>	<Date3>	
	Q.A.	<Init4>	<Date4>	

PROPRIETARY INFORMATION
 ALL RIGHTS RESERVED. NO PARTS OF THIS DOCUMENT
 MAY BE REPRODUCED, STORED IN A RETRIEVAL
 SYSTEM, OR TRANSMITTED, IN ANY FORM OR BY ANY
 MEANS, ELECTRONIC, MECHANICAL, PHOTOCOPIING,
 RECORDING OR OTHERWISE, WITHOUT THE PRIOR
 WRITTEN PERMISSION OF TADRAN TELEMATICS LTD,
 NOR USED IN WHOLE OR IN PART FOR ANY PURPOSE
 FOR ANY CUSTOMER EXCEPT TADRAN TELEMATICS.

REV	DESCRIPTION	CHNGE SHEET	E. C. N	DATE	DRAWN	CHECKED
<Rev><D>	<Description>	<Chngd>	<ECN>	<Date>	<Drawn>	<Checked>

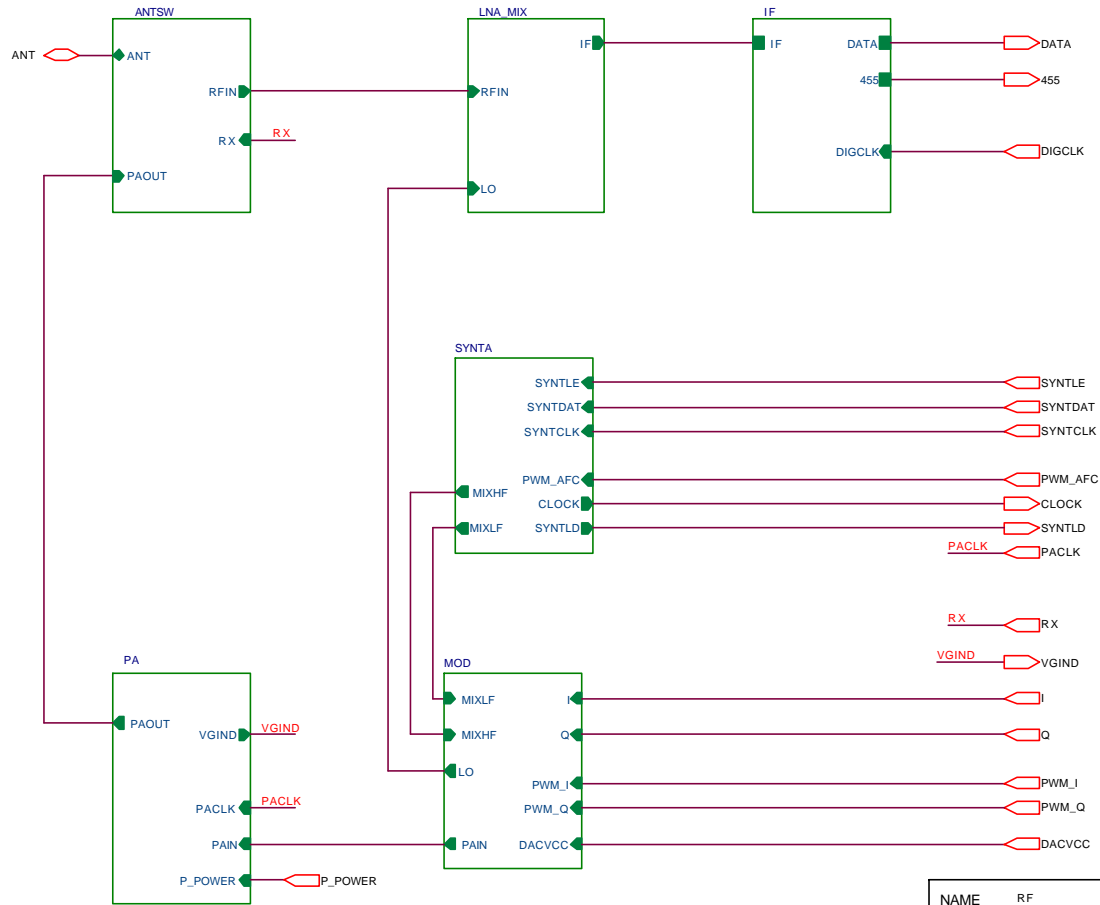

PROPRIETARY INFORMATION
 ALL RIGHTS RESERVED, NO PARTS OF THIS DOCUMENT
 MAY BE REPRODUCED, STORED IN A RETRIEVAL
 SYSTEM, OR TRANSMITTED, IN ANY FORM OR BY ANY
 MEANS, ELECTRONIC, MECHANICAL, PHOTOCOPIING,
 RECORDING OR OTHERWISE, WITHOUT THE PRIOR
 WRITTEN PERMISSION OF TADRAN TELEMATICS LTD,
 NOR USED IN WHOLE OR IN PART FOR ANY PURPOSE OR
 FOR ANY CUSTOMER EXCEPT TADRAN TELEMATICS.

NAME	RF	PROCESSING LEVEL	
		OPERATION	CATALOG NO.
Wednesday, June 21, 2000			
PROD/PROJ: PAL2 US A		DESIGNED	
		CHECKED	
		APPROVED	
		Q. A.	
			SHEET/OF 13 / 14
			A3 SIZE

PROPRIETARY INFORMATION
 ALL RIGHTS RESERVED. NO PARTS OF THIS DOCUMENT
 MAY BE REPRODUCED, STORED IN A RETRIEVAL
 SYSTEM OR TRANSMITTED, IN ANY FORM OR BY ANY
 MEANS, ELECTRONIC, MECHANICAL, PHOTOCOPIING,
 RECORDING OR OTHERWISE, WITHOUT THE PRIOR
 WRITTEN PERMISSION OF TADIRAN TELEMATICS LTD.
 NOR USED IN WHOLE OR IN PART FOR ANY PURPOSE
 FOR ANY CUSTOMER EXCEPT TADIRAN TELEMATICS.

REV	Δ	DESCRIPTION	CHNGD SHEET	E. C. N	DATE	DRAWN	CHECKED
<Rev>	<D>	<Description>	<Chngd>	<ECN>	<Date>	<Drawn>	<Checked>

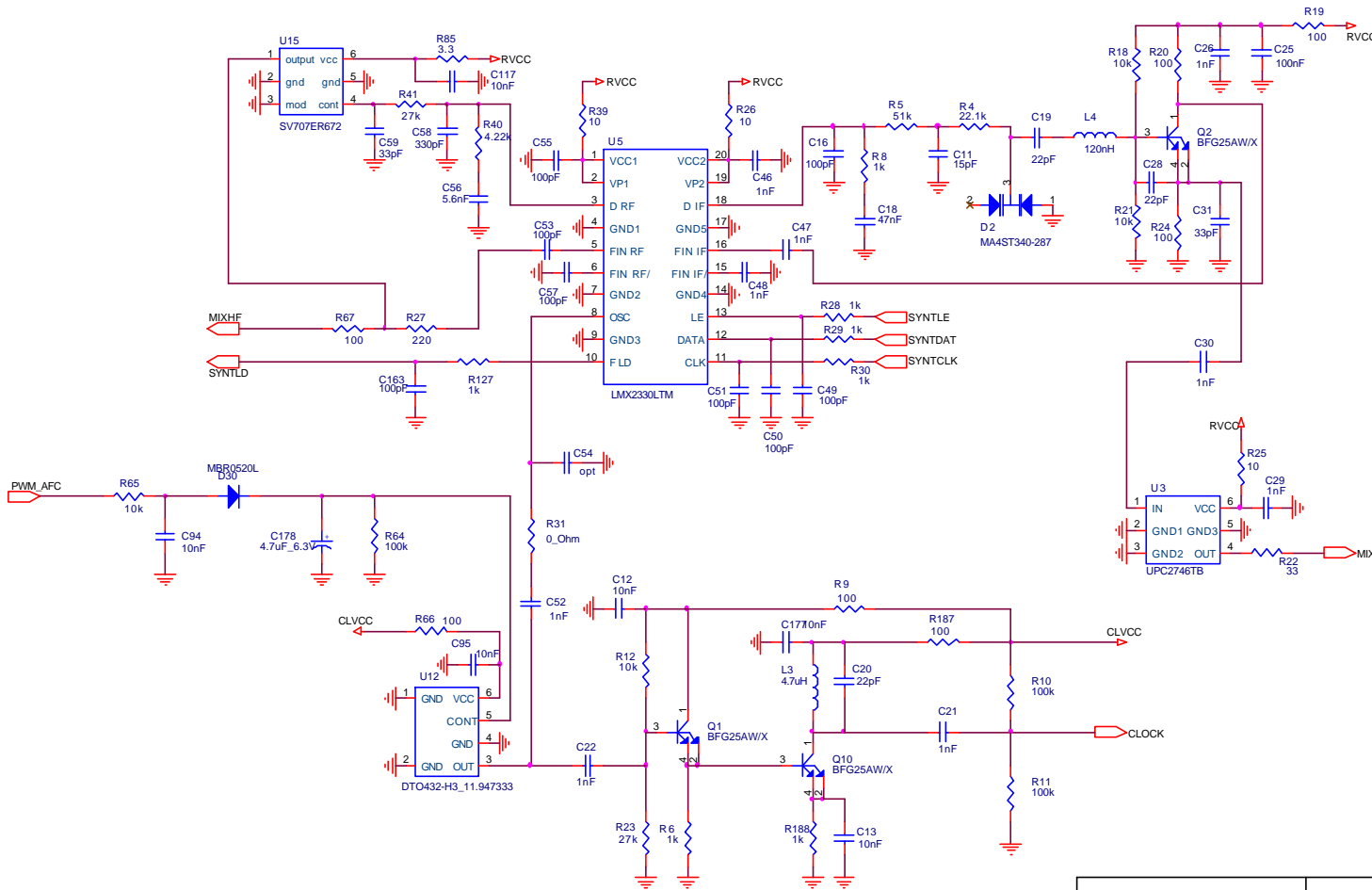

PROPRIETARY INFORMATION
 ALL RIGHTS RESERVED, NO PARTS OF THIS DOCUMENT
 MAY BE REPRODUCED, STORED IN A RETRIEVAL
 SYSTEM, OR TRANSMITTED, IN ANY FORM OR BY ANY
 MEANS, ELECTRONIC, MECHANICAL, PHOTOCOPIING,
 RECORDING OR OTHERWISE, WITHOUT THE PRIOR
 WRITTEN PERMISSION OF TADIRAN TELEMATICS LTD.
 NOR USED IN WHOLE OR IN PART FOR ANY PURPOSE
 FOR ANY CUSTOMER EXCEPT TADIRAN TELEMATICS.

NAME	SYNTA	PROCESSING LEVEL		SHEET/OF
		OPERATION	CATALOG NO.	
Monday, July 17, 2000				
PROD/PROJ:	PAL2 US A	DESIGNED		14 / 14
		CHECKED		
		APPROVED		
		Q. A.		SIZE A3