

REV	Δ	Description	Sheet Effected	Date	Drawn	Checked
A				29.09.05	D.Lanuel	S.Cohen
B	Δ	BW-3000 instead 1000	61,62	30.10.05	D.Lanuel	S.Cohen
	Δ	Par 14a added note	34	30.10.05	D.Lanuel	S.Cohen
	Δ	Added text	13,16,19,24, 31,37	30.10.05	D.Lanuel	S.Cohen

**EMC Laboratory**



# FP-200SAG

**Manufactured by  
TELEMATICS Ltd.**

## EMC Test Report

**According FCC Part 15 and Part 90 Requirements**

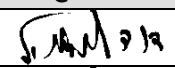
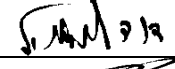
**SEP 2005**

	Function/Title	Name	Signature	Date
Prepared b	Test Engineer	D.Lanuel		30.10.05
Checked by	Test Engineer	D.Lanuel		30.10.05
Approved by	EMC Lab. Manager	S.Cohen		30.10.05

**Table of Contents**

<b>Para</b>		<b>Page</b>
1	<b>GENERAL INFORMATION.....</b>	<b>3</b>
2	<b>TEST SUMMARY AND SIGNATURES.....</b>	<b>4</b>
3	<b>EUT DESCRIPTION.....</b>	<b>6</b>
4	<b>6DB ACCORDING TO 15.247(A) (2).....</b>	<b>7</b>
5	<b>MAXIMUM PEAK OUTPUT POWER TEST ACCORDING 15.247(B) (3) .....</b>	<b>9</b>
6	<b>OUT OF BAND RADIATED EMISSION TEST ACCORDING TO 15.247(C),.....</b>	<b>12</b>
7	<b>RADIATED EMISSION IN RESTRICTED BANDS TEST ACCORDING 15.247(C), 15.205 AND 15.209 .....</b>	<b>14</b>
8	<b>PEAK POWER SPECTRAL DENSITY ACCORDING 15.247D.....</b>	<b>18</b>
9	<b>UNINTENTIONAL RADIATED EMISSION TEST ACCORDING TO 15.109.....</b>	<b>21</b>
10	<b>EFFECTIVE RADIATED POWER OF CARRIER 90.205 .....</b>	<b>23</b>
11	<b>OCCUPIED BANDWIDTH ACCORDING TO 90.209 .....</b>	<b>26</b>
12	<b>EMISSION MASK TEST .....</b>	<b>28</b>
13	<b>RADIATED EMISSION MEASUREMENTS ACCORDING TO 90.210 .....</b>	<b>29</b>
14	<b>FREQUENCY STABILITY TEST ACCORDING TO 90.213 .....</b>	<b>33</b>
15	<b>RADIATED EMISSION PART 15.109 .....</b>	<b>35</b>
16	<b>PLOTS.....</b>	<b>39</b>
17	<b>CORRECTION FACTORS .....</b>	<b>95</b>
18	<b>ABBREVIATIONS AND ACRONYMS .....</b>	<b>97</b>

## 1 GENERAL Information

### a. Description of equipment under test

Equipment under Test:	FP-200SAG
FCCID:	NTAFP200SAG
Manufacturer:	TELEMATICS.
Serial Numbers:	002
Mode of Operation:	TX MODE
Operating frequency:	2.4GHZ 915MHz
Year of Manufacture:	2005

### b. Applicant Information:

Applicant:	TELEMATICS Ltd.
Applicant Address	Hashoftim 26 Holon 58117 ISRAEL
Telephone:	+972-4-5575781
FAX:	+972-4-5575783
The testing was observed by:	ITSIK KANNER
Following applicant's personnel:	ITSIK KANNER

### c. Test Performance:

Date of reception for testing:	09.08.05
Dates of testing	09.08.05 - 01.09.05
Test Laboratory Location	TADIRAN EMC LAB, Hashoftim 26 Holon 58102 ISRAEL Tel: 972-3-5574476 Fax: 972-3- 5575320

Applicable EMC Specification:

Federal Communication Commission (FCC), Code of Federal Regulations 47, FCC, Part 15: Radio Frequency Devices, Sections 15.109, 15.209 & 15.207, 15.205, 15.247. FCC, Part 90: sections 90.205, 90.209, 90.210, 90.213

## 2 Test Summary and Signatures.

TADIRAN EMC Laboratory has completed testing of E.U.T in accordance with the requirements of the FCC part 15 and FCC part 90

The E.U.T was found to comply with the requirements of the FCC Part 15 Regulations given below

Test Description	Specification Reference	Date of Testing	Test Report Paragraph	Compliance PASS/FAIL
Occupied 6db bandwidth	15.247 (a) (2)	11.08.05	4	PASS
Max peak output power	15.247 (b) (3)	11.08.05	5	PASS
Out of band Radiated emission	15.247 (c)	11.08.05	6	PASS
Spurious emission radiated In Restricted band	15.209 15.205(a ,c)	11.08.05	7	PASS
Peak power spectral density	15.247 (d)	11.08.05	8	PASS
Unintentional radiated emission (RX 2.4GHz)	15.109	11.08.05	9	PASS

The E.U.T was found to comply with the requirements of the FCC Part 90 Regulations given below

Test Description	Specification Reference	Date of Testing	Test Report Paragraph	Compliance PASS/FAIL
Max output power	90.205	28.08.05	10	PASS
Occupied bandwidth	90.209	14.08.05	11	PASS
Emission Mask	90.210	01.09.05	12	PASS
Radiated Spurious emission	90.210	28.08.05	13	PASS
Frequency stability	90.213	01.09.05	14	PASS
Unintentional radiated emission (RX 915MHz, Stby)	15.109	01.09.05	15	PASS

a. **Test performed by:**

Mr. D. Lanuel Test Engineer



b. **Test Report prepared by:**

Mr. D. Lanuel Test Engineer



c. **Test Report Approved by:**

Mr. Samuel Cohen EMC Lab. Manager



### 3 EUT Description

#### a. General Information

The EUT is a TDMA electronic container seal, operating at 915 and 2440MHz for secure freight management system. The EUT identifies the cargo, records the sealing event and any subsequently detected tampering events, and communicates its stored data at highway speeds to a CVISN compatible infrastructure of TDMA readers.

#### b. E.U.T Test Configuration

EUT test configuration is shown in figure bellow

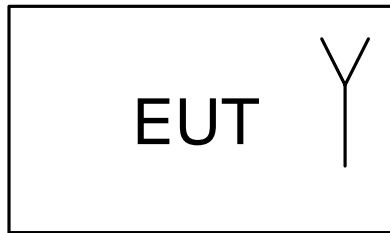

#### c. E.U.T Mode of Operation description

- (1) Transmit -2.4GHz
- (2) Receive -2.4GHz
- (3) Transmit -915MHz
- (4) Receive -915MHz
- (5) Stby

#### 4 6db According to 15.247(a) (2)

E.U.T: FP-200SAG S/N: 002  
 Test Method: ANSI 63.4  
 Date: 11.08.05  
 Relative Humidity: 26%  
 Ambient Temperature: 22c  
 Air Pressure: 1047hpa

Testing Engineer: D.Lanuel

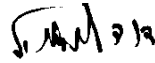

Date 15.09.05

a. **Test Results Summary & Conclusions**

The E.U.T was found in compliance with 6DB BANDWIDTH

b. **Limits of bandwidth**

The test unit shall meet the limits of Table 4.b

Table 4.b Limits For Bandwidth

Operating Frequency (MHz)	Minimum allowed bandwidth
2400 – 2483.5	≥500KHz for 6dbc

c. **Test Results**

Table 4.c Bandwidth Test Result

Bandwidth (MHz)	Bandwidth Max Limit(KHz)	Plot Results	PASS/ FAIL
13.0MHz	≥500KHz	1, 2	PASS

d. **Test Instrumentation and Equipment**

Table 4.d Test Instrumentation and Equipment

Item	Model	Manufacturer	Next Date Calibration
Spectrum Analyzer	8593E	HP	31.01.06
Double ridged guide ant	3105	EMCO	04.05.06

e. **Test Procedure**

The EUT output was set up as shown in figure 4e below  
The EUT was set to transmit modulated carrier

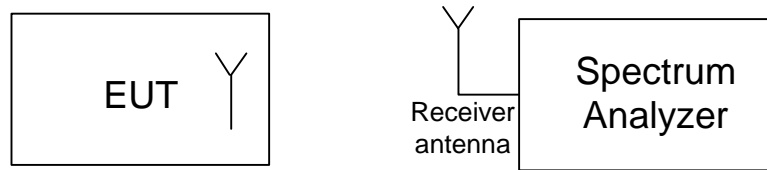

**Figure 4e Test Setup for Occupied Bandwidth test**



## 5 Maximum peak output power test according 15.247(b) (3)

E.U.T: FP-200SAG S/N: 002  
 Test Method: ANSI 63.4  
 Date: 11.08.05  
 Relative Humidity: 26%  
 Ambient Temperature: 22c  
 Air Pressure: 1047hpa  
 Test Setup: Figure 5f, 5f1

**Testing Engineer:** D.Lanuel



**Date** 15.09.05

### a. Test Results Summary & Conclusions

The E.U.T was found in compliance with peak output power requirement

### b. Limits

The test unit shall meet the limits of Table 5.b.

Table 5.b Limits For peak output power

Operating frequency range (MHz)	Peak Max Limits(dbm)	Equivalent Field Strength,3m , dbμV/m
2400 – 2483.5	30 (1W)	125.2

The maximum peak output power was calculate from the field strength as follows

$$E_{V/w} = \frac{1}{d} \sqrt{P_w \times 30 \times G}$$

P=peak output power in W  
 E=field strength in V/m  
 G=Transmitter antenna gain  
 D=test distance

For 3m distance 
$$P_{dbm} = E_{dbuV} - G_{dbi} - 95.2db$$

**c. Test Results**

Table 5.c Peak output power Result

Frequency (MHz)	Peak Result (db $\mu$ V/m)	EUT Ant Gain	Peak out power (dBm)	Limit (dbm)	Plots Result	Pass/Fail
2440.449	98.75	0	3.56	30	3	PASS

\*See calculation bellow-based on test procedure paragraph 5d

- a) BW correction factor is:  $10\log 6\text{db RBW of EUT emission/Spectrum analyzer RBW}$
- b)  $10\log 13/3=6.36$
- c) Output power:  $92.4+6.35=98.76$

**d. Test Instrumentation and Equipment**

Table5.d Test Instrumentation and Equipment

Item	Model	Manufacturer	Next Date Calibration
Spectrum Analyzer	8593E	HP	31.01.06
Double ridged guide ant	3105	EMCO	04.05.06

**e. Test Procedure**

- (1) General
  - a) The test was performed according tests setup in paragraph 5f1, 5f1
  - b) The EUT adjusted to produce maximum RF power output
  - c) The EUT was set to transmit modulated carrier
- (2) Spectrum analyzer measured the transmitter peak output power while the RBW of analyzer is 3MHz and the RBW of transmitter is 13MHz.
- (3) When the analyzer RBW is not large enough as required. The peak output power procedure is as follows:
  - a) Set the RBW and VBW to the maximum available.
  - b) Set the band limit to 6db
  - c) Set sweep to automatic
  - d) Set the span just enough to capture the emission
  - e) Use the peak detector on max hold
  - f) Set the analyzer on linear mode display
  - g) Let the emission stabilize before making a final reading

**BW correction factor is:  $10\log 6\text{db EUT BW of emission/analyzer RBW}$**

(4) Test Procedure

- a) The EUT was placed on the top of a rotating table 0.8 meters above the ground at a chamber shielded
- b) The E.U.T was set 3 meters away from the receiving antenna, which was mounted on the top of a variable-height antenna tower.
- c) The Antenna height varied from one meter above the ground over its full-allowed range of travel and the table was rotated 360°to determine the maximum value of the field strength
- d) The antenna was set both horizontal and vertical polarization.
- e) Δ the measurement were taken after selecting the EUT axis for maximum emission

f. **Test Setup**

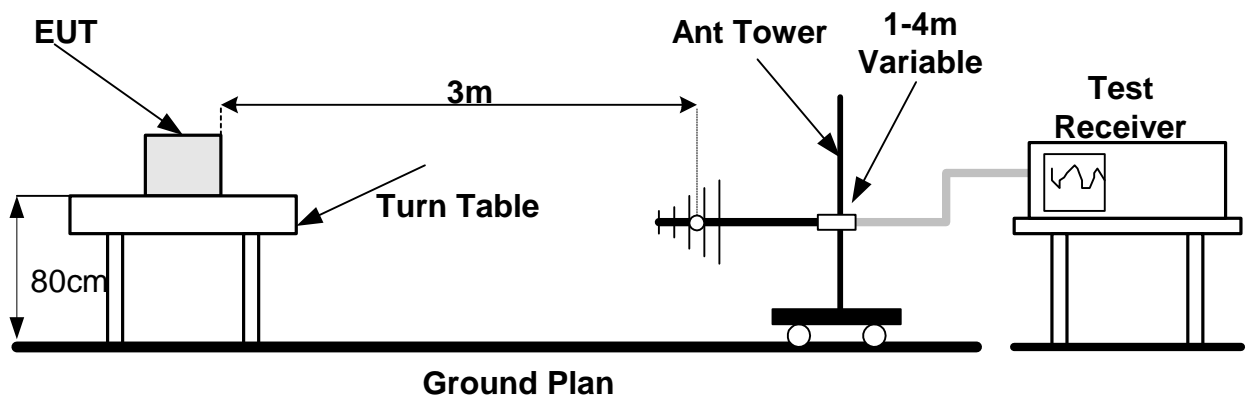

Figure 5.f Radiated Emission Set up

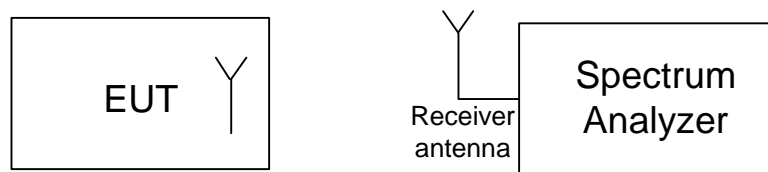

Figure 5f1 Test configuration for peak output power radiated emission

**6 Out of band radiated emission test according to 15.247(c),**

E.U.T: FP-200SAG S/N: 002  
 Test Method: ANSI 63.4  
 Date: 11.08.05  
 Relative Humidity: 26%  
 Ambient Temperature: 22c  
 Air Pressure: 1047hpa  
 Test Setup: Figure 6.e

**Testing Engineer:** D.Lanuel *[Signature]* **Date** 15.09.05

**a. Test Results Summary & Conclusions**

The E.U.T was found in compliance with Out of band radiated emission test according to 15.247(c)

**b. Limits of out of band conducted emission according to 15.247 (c)**

The test unit shall meet the limits of Table 6.b.

Table 6.b Limits For 15.231(b)

Frequency range (MHz)	Limits dbc	Peak out BW-100KHz (dBµV/m)	Limits (dBµV/m)	Plot Ref
0.009 – 18000	20	77.5	57.5	4

**c. Test Results**

Table 6.c Results For 15.231(b)

Operating Frequency (MHz)	Frequency range (MHz)	Results (dBµV/m)	Plots Result
2400MHz	0.009 – 18000	All emission were found Min 30db below the specified limits	5 - 9

**d. Test Instrumentation and Equipment**

Table 6.d Test Instrumentation and Equipment

Item	Model	Manufacturer	Next Date Calibration
Loop Antenna	95010-1	Rohde&Schw	N.P.C.R
Broadband Antenna	BTA-L	Frankonia	10.04.06
Double Ridged Guide Ant (1 - 18) GHz	3105	EMCO	02.05.06
Low Noise Amplifier (0-1GHz)	AM-1300-N	MITEQ	14.01.06
Low Noise Amplifier (1-4GHz)	AMM 003N	AVANTEK	14.01.06
Low Noise Amplifier (2-6GHz)	MWA-02060	ELISRA	14.01.06
Low Noise Amplifier (6-18GHz)	MWA-06180	ELISRA	14.01.06
Spectrum Analyzer	8593A	hp	31.01.06
Band reject Filter 2.4GHz	WRCC2400	Wainwright	06.05.07

**e. Test Procedure**

- (1) The EUT was set as shown in figure 6e
- (2) The resolution bandwidth of spectrum analyzer was set to 100 KHz
- (3) Test Procedure
  - a) The EUT was placed on the top of a rotating table 0.8 meters above the ground at a chamber shielded
  - b) The E.U.T was set 3 meters away from the receiving antenna, which was mounted on the top of a variable-height antenna tower.
  - c) The Antenna height varied from one meter above the ground over its full-allowed range of travel and the table was rotated 360°to determine the maximum value of the field strength
  - d) The antenna was set both horizontal and vertical polarization.
  - e) Δ the measurement were taken after selecting the EUT axis for maximum emission

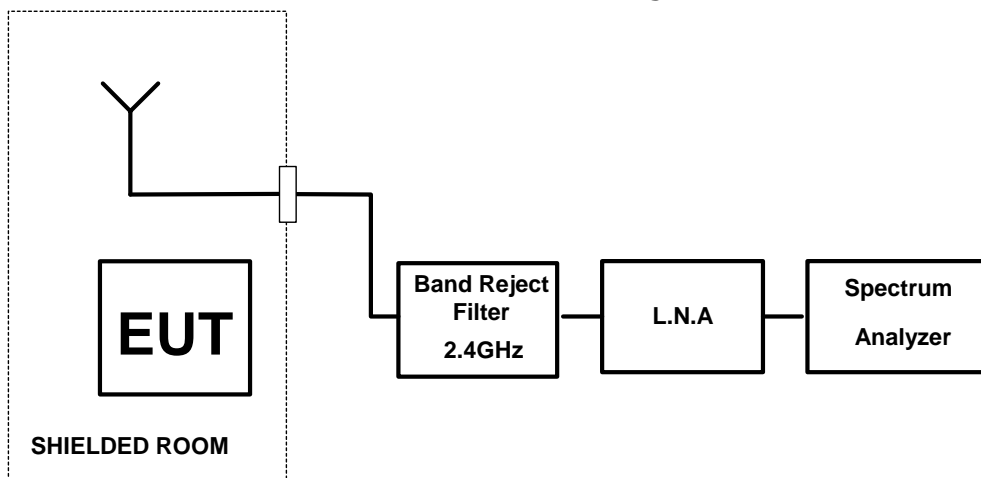
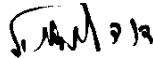

Figure 6e Test Setup for out of BAND radiated emission

## 7 Radiated emission in restricted bands test according 15.247(c), 15.205 and 15.209

E.U.T: FP-200SAG S/N: 002  
 Test Method: ANSI 63.4  
 Date: 11.08.05  
 Relative Humidity: 26%  
 Ambient Temperature: 22c  
 Air Pressure: 1047hpa  
 Test Setup: Figure 7.e – 7.e.1

Testing Engineer: D.Lanuel



Date 15.09.05

### a. Test Results Summary & Conclusions

The E.U.T was found in compliance with radiated emission restricted band test

- b. **Limit:** Radiated emission, which fall in the restricted bandwidth must comply with 15.209(a) Limits. See limits in table 7b below.

Table 7.b Limits For 15.209 Class B equipment

Frequency Range (MHz)	Quasi-peak Limits (dB $\mu$ V/m)	Peak Limit	Average Limit
0.009 – 0.49	128 – 93.8	NA	NA
0.49 – 1.705	73.8 – 63.0		
1.705 - 30	69.5		
30 - 88	40		
88 - 216	43.5		
216 - 960	46		
960 - 1000	54		
Above 1000	NA	74	54

**c. Results**
**(1) Preliminary Results**

Table 7.c1 Preliminary test results

Frequency Range MHz	Antenna polarity	RBW	Plots	PASS/ FAIL
0.09 – 0.15	Vertical	1KHz	10	PASS
0.09 – 0.15	Horizontal	1KHz	11	PASS
0.15 - 30	Vertical	9KHz	12	PASS
0.15 - 30	Horizontal	9KHz	13	PASS
30 - 1000	Both	120KHz	14	PASS
1000 - 2800	Both	1000KHZ	15	PASS
2800 - 6000	Both	1000KHZ	16	PASS
6000 - 10000	Both	1000KHZ	17	PASS
10000 - 17000	Both	1000KHZ	18	PASS

**(2) Final Test Results**

Table 7.c2 Peak field strength

Freq (MHz)	Field strength dB $\mu$ V/m	Peak Limit	Plot Ref	Angle (degr)	Height (m)	Pass/fail
4881.123	57.1	74	16	120	1	pass
0.009 - 9200	All emission in restricted band were found at least 20db below the specified limits					

Table 7.c3 Average field strength

Freq (MHz)	Field strength dB $\mu$ V/m	Average Limit	Plot Ref	Angle (degr)	Height (m)	Pass/fail
4881.123	42.6	54	19	120	1	pass
0.009 - 9200	All emission in restricted band were found at least 20db below the specified limits					

**d. Test Instrumentation and Equipment**

Table 7.d Test Instrumentation and Equipment

Item	Model	Manufacturer	Next Date Calibration
Loop Antenna	95010-1	Rohde&Schw	N.P.C.R
Broadband Antenna	BTA-L	Frankonia	10.04.06
Double Ridged Guide Ant (1 - 18) GHz	3105	EMCO	02.05.06
Low Noise Amplifier (0-1GHz)	AM-1300-N	MITEQ	14.01.06
Low Noise Amplifier (1-4GHz)	AMM 003N	AVANTEK	14.01.06
Low Noise Amplifier (2-6GHz)	MWA-02060	ELISRA	14.01.06
Low Noise Amplifier (6-18GHz)	MWA-06180	ELISRA	14.01.06
Spectrum Analyzer	8593A	hp	31.01.06
Band reject Filter 2.4GHz	WRCC2400	Wainwright	06.05.07

**e. Test Procedure**

## (1) General

- a) The test was performed with transmitter operating 2400MHz
- b) The test was performed according tests setup in paragraph 7e

## (2) Preliminary Test Procedure

- a) The EUT was placed on the top of a rotating table 0.8 meters above the ground at a chamber shielded
- b) The E.U.T was set 3 meters away from the receiving antenna, which was mounted on the top of a variable-height antenna tower.
- c) The Antenna height varied from one meter above the ground over its full-allowed range of travel and the table was rotated 360°to determine the maximum value of the field strength
- d) The antenna was set both horizontal and vertical polarization.
- e) Δ the measurement were taken after selecting the EUT axis for maximum emission

## (3) Final Test Procedure

- a) The EUT was tested at open area for each suspected emission
- b) The test procedure was performed according paragraph (1) and figure 7e, 7e1



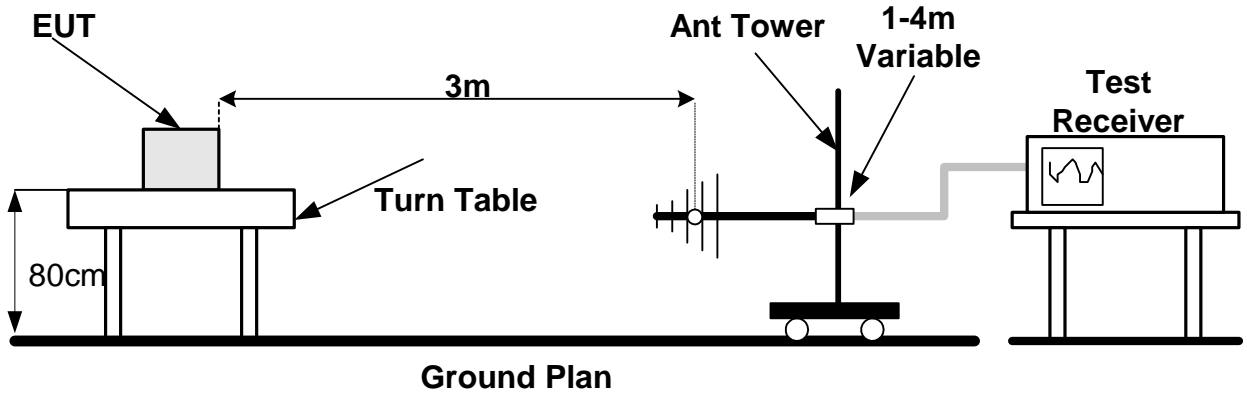

**Ground Plan**  
Figure 7e Radiated Emission Set up

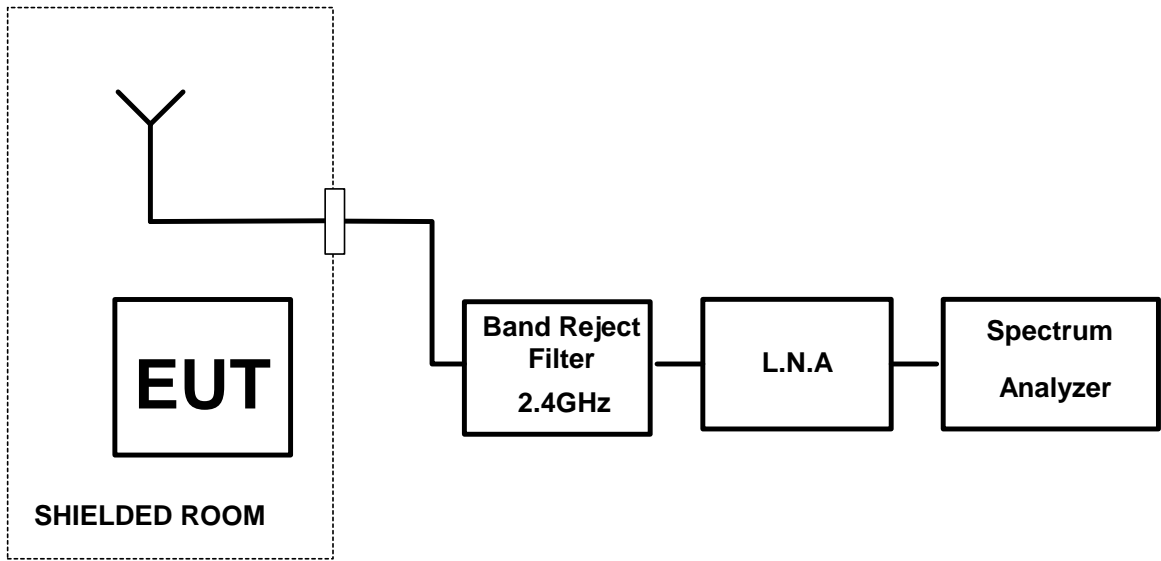

Figure 7.e.1 Radiated emission Test configuration

## 8 Peak power spectral density according 15.247d

E.U.T:	FP-200SAG	S/N: 002
Test Method:	ANSI 63.4	
Date:	11.08.05	
Relative Humidity:	26%	
Ambient Temperature:	22c	
Air Pressure:	1047hpa	
Test Setup:	Figure 8.e	

Testing Engineer: D.Lanuel



Date 15.09.05

### a. Test Results Summary & Conclusions

The E.U.T was found in compliance peak power spectral density test

### b. Limit

The peak power spectral density conducted from the intentional radiator to the antenna shall not be greater than 8 dbm in any 3 KHz band during any time interval of continuous transmission

Table 8.b

Transmit Freq, MHz	Measurement Bandwidth, KHz	Max Peak Power Density, dbm	Equivalent field strength limit 3m dBμV
2400	3	8	103.2

### c. Test Results

Table 8.c

Test results of field strength peak power density measurement

Freq (MHz)	Field strength dBμV/m	EUT ant gain, dbi	Limit	margin	Angle (degr)	Plots	Pass/fail
2440.449	78.6	0	103.2	-24.6	120	20, 21	pass

Table 8.c1

Test results of substitution peak power density measurement

Freq (MHz)	Field strength dBμV/m	RF gen out dbm	Ant gain, dbi	Cable loss, db	Peak Power density	Limit dbm	Pass/fail
2440.449	78.6	-27.9	10	1.5	-19.4	8	pass

**d. Test Instrumentation and Equipment**

Table 8.d                      Test Instrumentation and Equipment

Item	Model	Manufacturer	Next Date Calibration
Spectrum Analyzer	8593E	HP	31.01.06
Double ridged guide ant	3105	EMCO	04.05.06

**e. Test Procedure**

**Test Procedure for field strength measurement**

- (1) The EUT was setup as shown in figure 8e1
- (2) The EUT was adjusted to produce maximum power output  $\Delta$  after selecting the EUT axis for maximum emission
- (3) The Spectrum analyzer was set to 3 KHz bandwidth

**Test Procedure for field strength peak power density measurement**

- (4) The EUT was setup as shown in figure 8e2
- (5) RF signal generator was set to the EUT carrier frequency and the RF output level was adjusted to produce the same field strength as it was measured from the EUT
- (6) The test antenna height was swept to find maximum emission from substitute antenna and RF signal generator was adjusted to produce the same field strength as it was measured from the EUT

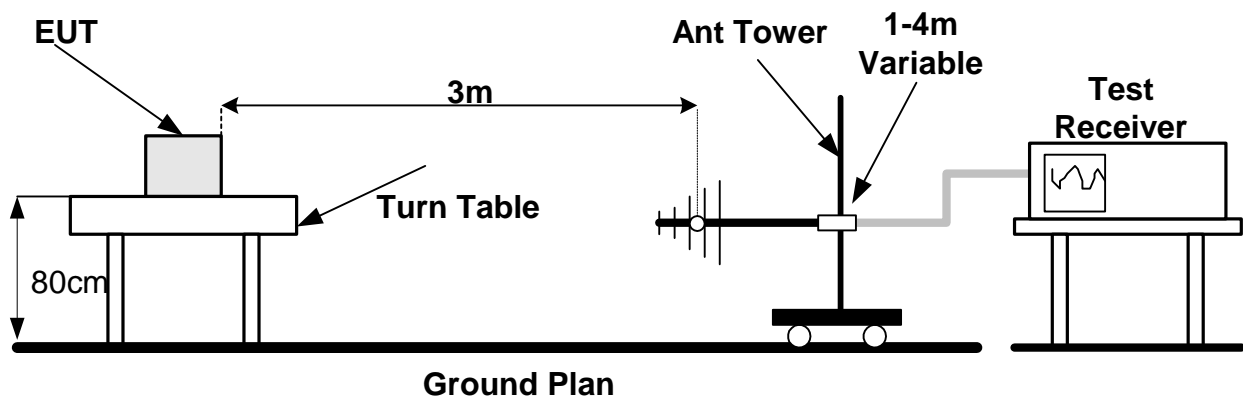

Figure 8e1 Test setup field strength peak power density measurement

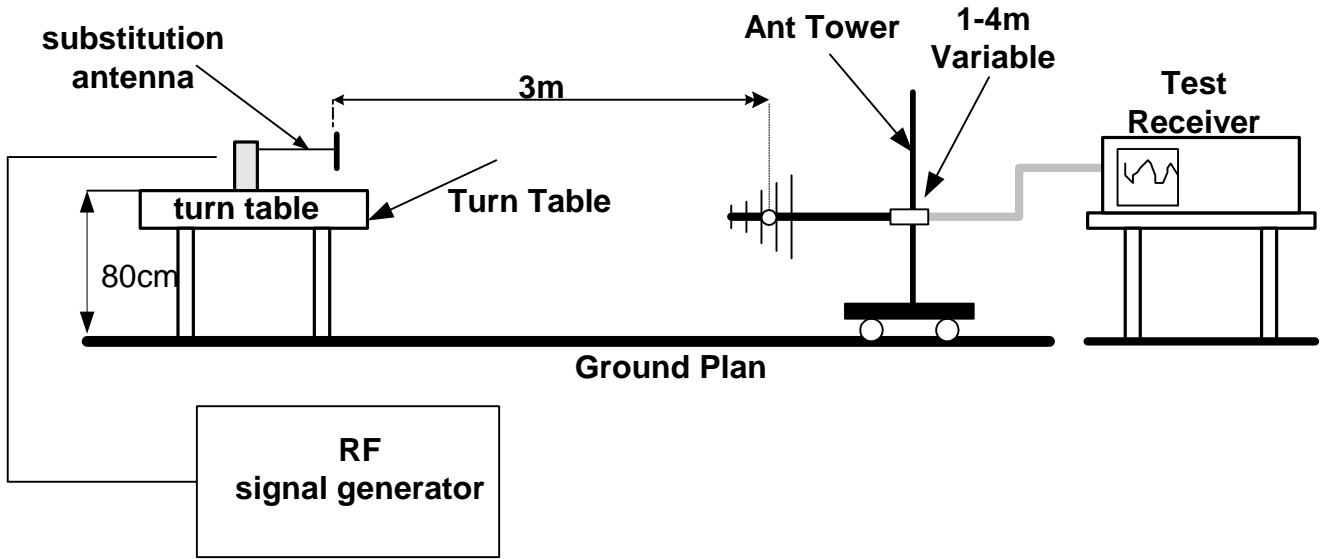
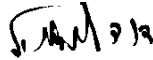

Figure 8e2 Test setup of substitution peak power density measurement

**9 Unintentional radiated emission test according to 15.109**

E.U.T: FP-200SAG S/N: 002  
 Test Method: ANSI 63.4  
 Date: 11.08.05  
 Relative Humidity: 26%  
 Ambient Temperature: 22c  
 Air Pressure: 1047hpa

**Testing Engineer:** D.Lanuel



**Date** 15.09.05

a. **Test Results Summary & Conclusions**

The E.U.T was found in compliance with unintentional radiated emission requirements.

b. **Limit:**

Unintentional radiated emission must comply with 15.109 Limits. See limits in table 9b bellow.

Table 9b Limits For 15.109 Class B equipment

Frequency Range (MHz)	Quasi-peak Limits (dB $\mu$ V/m)
30 - 88	40
88 - 216	43
216 - 960	46
960 - 2000	54

**c. Test Results**

Table 9.c .Preliminary test results

Antenna Polarization	Frequency Range(MHz)	Plots Results	PASS/FAIL
Both	30-1000	22	PASS
	1-2.8GHz	23	PASS
	2.8 – 6GHz	24	PASS
	6GHz – 6.5GHz	-	PASS
	6.5GHz – 9.2GHz	-	PASS

Table 9c1 Six Highest 15.109

Freq. (MHz)	QP Reading (db $\mu$ V/m)	QP Limit (db $\mu$ V/m)	Margin (db)	Compliance PASS/FAIL
30-10000	The emission at least 20db bellow the limit			

**d. Test Instrumentation and Equipment**

Table 9.d Test Instrumentation and Equipment

Item	Model	Manufacturer	Next Date Calibration
Broadband Antenna	BTA-L	Frankonia	10.04.06
Double Ridged Guide Ant (1 - 18) GHz	3105	EMCO	02.05.06
Low Noise Amplifier (0-1GHz)	AM-1300-N	MITEQ	14.01.06
Low Noise Amplifier (1-4GHz)	AMM 003N	AVANTEK	14.01.06
Low Noise Amplifier (2-6GHz)	MWA-02060	ELISRA	14.01.06
Low Noise Amplifier (6-18GHz)	MWA-06180	ELISRA	14.01.06
Spectrum Analyzer	8593A	hp	31.01.06

**e. Procedure**

The EUT output was connected to the spectrum analyzer through appropriate low noise amplifier while the EUT is in 2.4GHz RX mode.

## 10 Effective radiated power of carrier 90.205

E.U.T: FP-200SAG S/N: 002  
 Test Method: ANSI 63.4  
 Date: 28/08/05  
 Relative Humidity: 26%  
 Ambient Temperature: 22c  
 Air Pressure: 1047hpa  
 Test Setup: Figure 8.e

**Testing Engineer:** D.Lanuel



**Date** 15.09.05

### a. Test Results Summary & Conclusions

The E.U.T was found in compliance effective radiated power test

### b. Limit

Table 10.b Limit of effective radiated power

Transmit Freq, MHz	ERP (Mw)	ERP (dbm)	Equivalent field strength limit 3m dbµV
915	30	44.7	142*

\*Equivalent field strength limit was calculated as follows:

$$E_{v/w} = \frac{1}{d} \sqrt{P_w \times 30 \times 1.64}$$

P=ERP in W

E=field strength in V/m

1.64=gain of ideal dipole

D=test distance in meter

**c. Test Results**

Table 10.c Test results of field strength y measurement

Freq (MHz)	Field strength dB $\mu$ V/m	Limit dB $\mu$ V/m	Margin db	Ant pol	Ant height	Plots Ref	Pass/fail
914.88	106.5	142	-35.5	V	1.6	25	pass
914.88	105.8	142	-36.2	H	1	26	pass

Table 10.c1 Test results of ERP

Freq (MHz)	Field strength dB $\mu$ V/m	Ant pol	RF gen Out dbm	Cable loss	ERP dbm	Limit dbm	Margin db	Pass/fail
914.88	106.5	V	10.5	1.1	9.4	44.7	-35.3	pass
914.88	105.8	H	12.8	1.1	11.7	44.7	-33	pass

**d. Test Instrumentation and Equipment**

Table 10.d Test Instrumentation and Equipment

Item	Model	Manufacturer	Next Date Calibration
Spectrum Analyzer	8593E	HP	31.01.06
Broadband Antenna	BTA-L	FRANKONIA	10.04.06

**e. Test Procedure**
**Test Procedure for field strength measurement**

- (1) The EUT was setup as shown in figure 10e1
- (2) The EUT was adjusted to produce maximum power output  $\Delta$  after selecting the EUT axis for maximum emission
- (3) The Spectrum analyzer was set to 3 MHz bandwidth

**Test Procedure for field strength peak power density measurement**

- (4) The EUT was setup as shown in figure 10e2
- (5) RF signal generator was set to the EUT carrier frequency and the RF output level was adjusted to produce the same field strength as it was measured from the EUT
- (6) The test antenna height was swept to find maximum emission from substitute antenna and RF signal generator was adjusted to produce the same field strength as it was measured from the EUT
- (7) The ERP was calculated as a sum of signal generator output power in dbm and antenna gain
- (8) Paragraph 4 through 7 was performed in both horizontal and vertical polarization of the test antenna



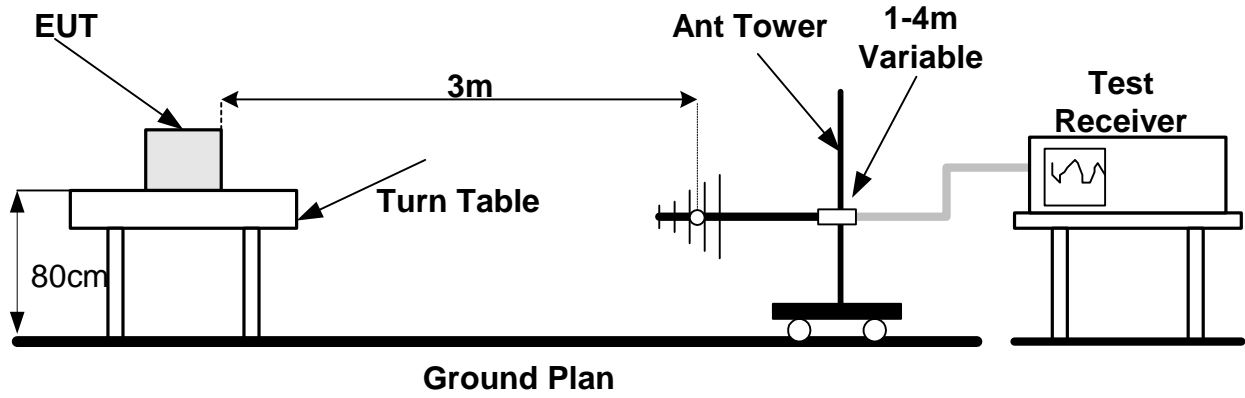

Figure 10e1 Test setup field strength peak power density measurement

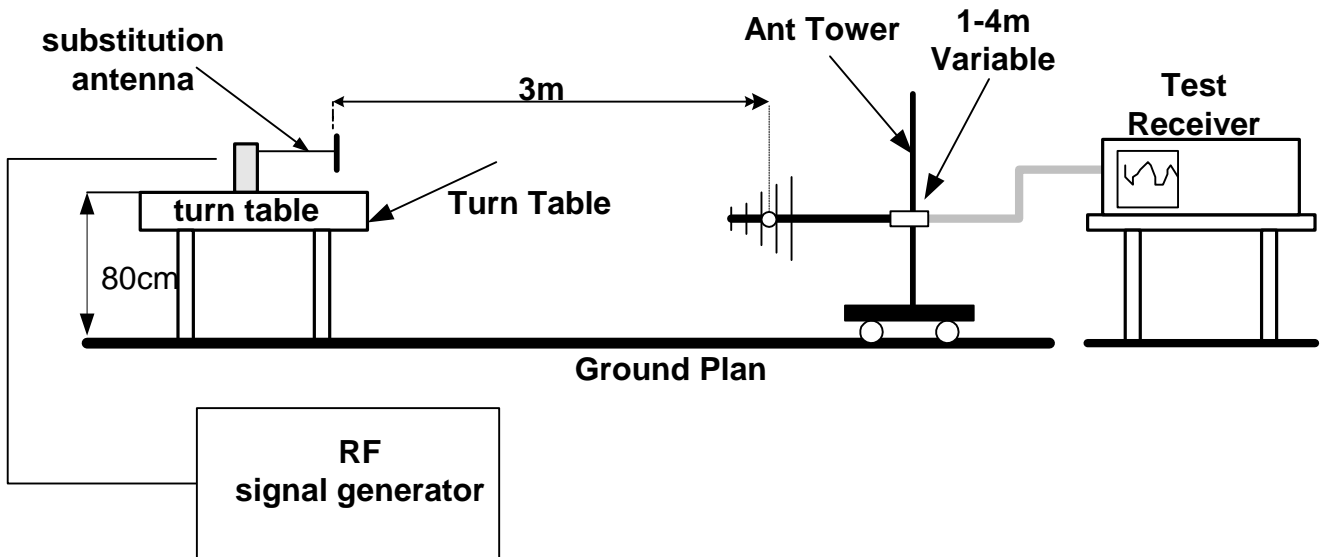
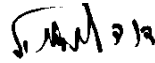

Figure 10e2 Test setup of substitution peak power density measurement

## 11 Occupied bandwidth According to 90.209

E.U.T: FP-200SAG S/N: 002  
 Test Method: ANSI 63.4  
 Date: 14/08/05  
 Relative Humidity: 26%  
 Ambient Temperature: 22c  
 Air Pressure: 1047hpa

Testing Engineer: D.Lanuel



Date 15.09.05

### a. Test Results Summary & Conclusions

The E.U.T was found in compliance with OCCUPIED BANDWIDTH

### b. Limits of bandwidth

The test unit shall meet the limits of Table 11.b

Table 11.b Limits For Bandwidth

Operating Frequency (MHz)	Reference points (dbc)	Maximum allowed bandwidth (KHz)
915	26	12000

### c. Test Results

Table 11.c Bandwidth Test Result

Bandwidth (kHz)	Bandwidth Max Limit(kHz)	Plot Results	PASS/FAIL
6500	12000	27,28	PASS

### d. Test Instrumentation and Equipment

Table 11.d Test Instrumentation and Equipment

Item	Model	Manufacturer	Next Date Calibration
Spectrum Analyzer	8593E	HP	31.01.06
Broadband Antenna	BTA-L	FRANKONIA	10.04.06

e. **Test Procedure**

The EUT output was set up as shown in figure below  
The EUT was set to transmit modulated carrier

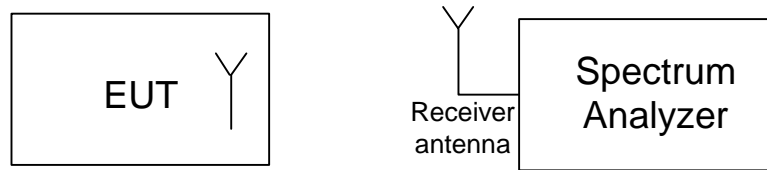
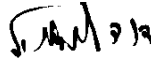

Figure 11e Test Setup for Occupied Bandwidth test

## 12 Emission mask test

E.U.T: FP-200SAG S/N: 002  
 Test Method: ANSI 63.4  
 Date: 01/09/05  
 Relative Humidity: 26%  
 Ambient Temperature: 22c  
 Air Pressure: 1047hpa

**Testing Engineer:** D.Lanuel



**Date** 15.09.05

a. **Test Results Summary & Conclusions**

The E.U.T was found in compliance with emission mask test

b. **Limits of bandwidth**

The test unit shall meet the limits of Table 12.b

Table 12.b Limits For **emission mask k**

Operating Frequency (MHz)	Attenuation below carrier
909.75 – 921.75	0
Outside the sub band	55+10logP(W)

c. **Test Results**

Table 12.c **emission mask k** Test Result

Frequency (MHz)	Limit	Plot Ref	PASS/FAIL
915	Emission mask k	29, 30	pass

d. **Test Instrumentation and Equipment**

Table 12.d Test Instrumentation and Equipment

Item	Model	Manufacturer	Next Date Calibration
Spectrum Analyzer	8593E	HP	31.01.06
Broadband Antenna	BTA-L	FRANKONIA	10.04.06

e. **Test Procedure**

The EUT output was set up as shown in figure below

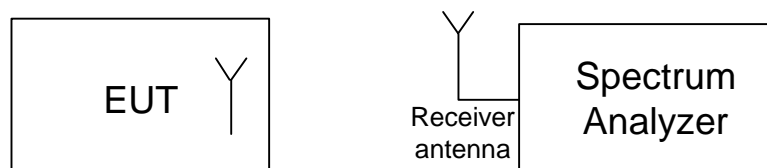



Figure 12e Test Setup for Occupied Bandwidth test

### 13 Radiated Emission Measurements According to 90.210

E.U.T: FP-200SAG S/N: 002  
 Test Method: ANSI 63.4  
 Date: 28/08/05  
 Relative Humidity: 26%  
 Ambient Temperature: 22c  
 Air Pressure: 1047hpa  
 Test Setup: Figure 13.e

**Testing Engineer:** D.Lanuel



**Date** 15.09.05

a. **Test Results Summary & Conclusions**

The E.U.T was found in compliance effective radiated power test

b. **Limits of radiated emission**

The test unit shall meet the limits of Table 13.b

Table 13.b Limits For radiated emission

Transmit Freq, (MHz)	Limit (dbc)	ERP (dbm)	Equivalent field strength limit 3m dbµV
0.009 – 10 <sup>th</sup> Harmonics	55+10logP	-25	72.4

\*Equivalent field strength limit was calculated as follows:

$$E_{V/w} = \frac{1}{d} \sqrt{P_W \times 30 \times 1.64}$$

P=ERP in W

E=field strength in V/m

1.64=gain of ideal dipole

D=test distance in meter

**c. Test Results**

Table 13.b Results for radiated emission

Transmit Freq,(MHz)	Limit (dbc)	ERP (dbm)	field strength limit 3m dB $\mu$ V	Plots	Pass/ fail
0.009 – 10k	55+10logP	-25	72.4	31-53	pass

Table 13.c Test results of field strength measurement

Freq (MHz)	Field strength dB $\mu$ V/m	Limit dB $\mu$ V/m	Margin db	Ant pol	Ant height	table degrees	Pass/ fail
1829.8	60.0	72.4	-12.4	V	1	240	pass
1829.8	56.1	72.4	-16.3	H	1.6	60	pass
3659.8	53.2	72.4	-19.2	V	1	120	pass
3659.8	49.3	72.4	-23.1	H	1.6	240	pass
4574.7	44.4	72.4	-28	V	1	180	pass
4574.7	48.4	72.4	-24	H	1.6	240	pass
5489.7	58.4	72.4	-14	V	1.3	120	pass
5489.7	58.7	72.4	-13.7	H	1.6	120	pass
7319.5	59.3	72.4	-13.1	V	1.3	180	pass
7319.5	52.4	72.4	-20	H	1.6	180	pass

Table 13.c1 Test results of ERP

Freq (MHz)	Field strength dB $\mu$ V/m	Ant pol	RF gen out dbm	Ant gain , dbd	Cable loss	ERP dbm	Limit dbm	Pass/ fail
1829.8	60.0	V	-41.4	7.85	1.2	-34.75	-25	pass
1829.8	56.1	H	-43.5	7.85	1.22	-36.87	-25	pass
3659.8	53.2	V	-47.0	8.05	1.75	-40.65	-25	pass
3659.8	49.3	H	-53.3	8.05	1.75	-47.00	-25	pass
4574.7	44.4	V	-56.0	8.35	2.2	-49.85	-25	pass
4574.7	48.4	H	-52.9	8.35	2.2	-46.75	-25	pass
5489.7	58.4	V	-42.3	9.15	2.4	-35.55	-25	pass
5489.7	58.7	H	-41.7	9.15	2.4	-34.95	-25	pass
7319.5	59.3	V	-41.0	10.55	2.7	-34.55	-25	pass
7319.5	52.4	H	-45.7	10.55	2.7	-39.25	-25	pass

**d. Test Instrumentation and Equipment**

Table 13.d Test Instrumentation and Equipment

Item	Model	Manufacturer	Next Date Calibration
Spectrum Analyzer	8593E	HP	31.01.06
Broadband Antenna	BTA-L	FRANKONIA	10.04.06

**e. Test Procedure**

**Test Procedure for field strength measurement**

- (1) The EUT was setup as shown in figure 13e1
- (2) The EUT was adjusted to produce maximum power output  $\Delta$  after selecting the EUT axis for maximum emission
- (3) The Spectrum analyzer was set to 100 KHz bandwidth

**Test Procedure for field strength peak power density measurement**

- (4) The EUT was setup as shown in figure 13e2
- (5) RF signal generator was set to the EUT carrier frequency and the RF output level was adjusted to produce the same field strength as it was measured from the EUT
- (6) The test antenna height was swept to find maximum emission from substitute antenna and RF signal generator was adjusted to produce the same field strength as it was measured from the EUT
- (7) The ERP was calculated as a sum of signal generator output power in dbm and antenna gain
- (8) Paragraph 4 through 7 was performed in both horizontal and vertical polarization of the test antenna

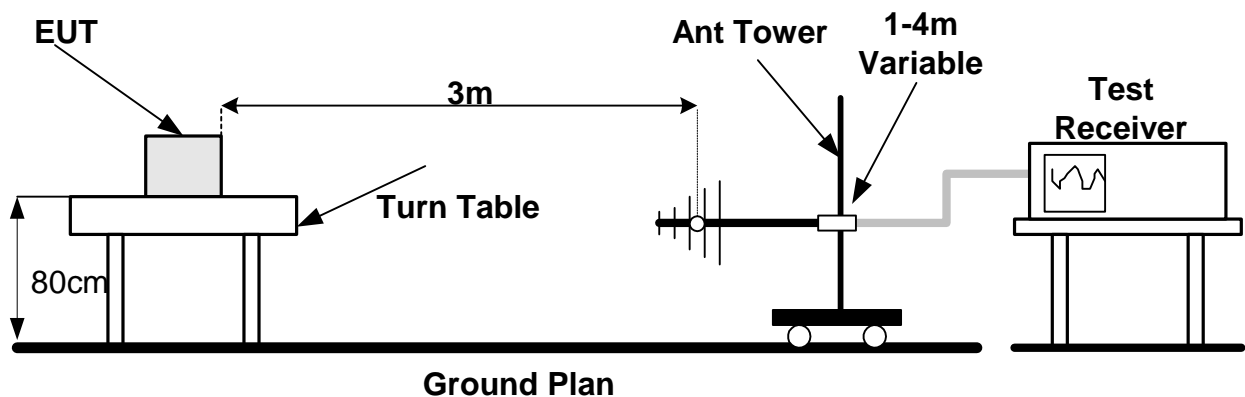

Figure 13e1 Test setup field strength peak power density measurement

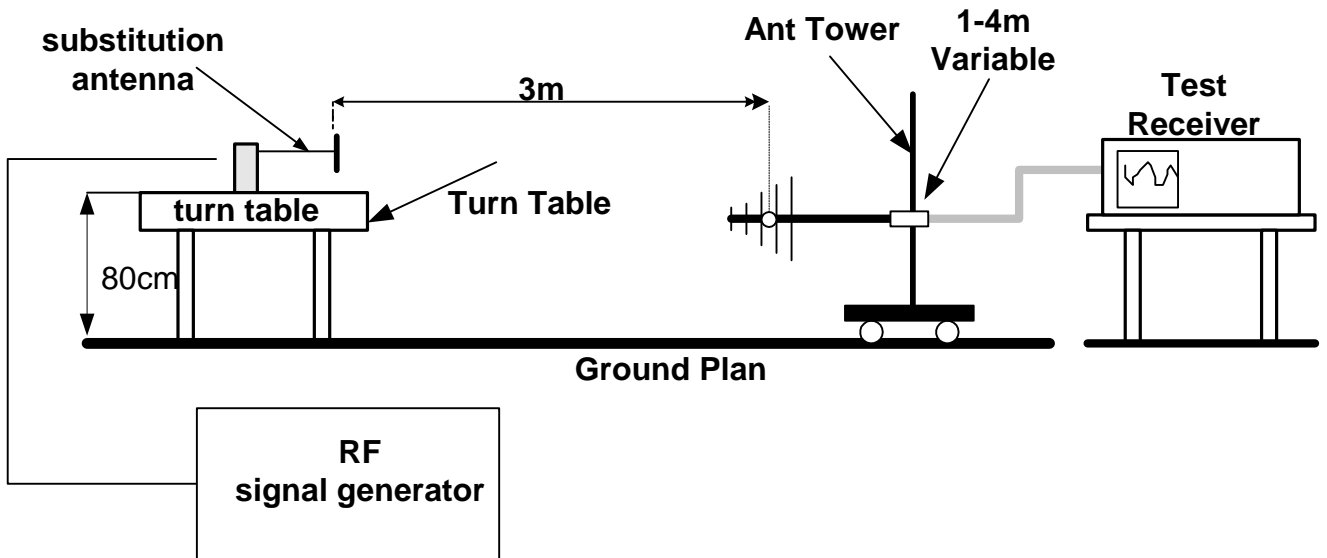



Figure 13e2 Test setup of substitution peak power density measurement



## 14 Frequency stability test According to 90.213

E.U.T:	FP-200SAG	S/N: 002
Test Method:	ANSI 63.4	
Date:	01/09/05	
Relative Humidity:	26%	
Ambient Temperature:	22c	
Air Pressure:	1047hpa	
Test Setup:	Figure 14.e	

Testing Engineer: D.Lanuel



Date 15.09.05

a. **Test Results Summary & Conclusions**

**ΔThe device is not subject to frequency tolerance restriction**

b. **Limits of frequency stability**

The test unit shall meet the limits of Table 14.b

Table 14.b Limits For frequency stability

Transmit Freq, (MHz)	Limit ppm	Limit (Hz)
915	2.5	2287.5

c. **Test Results**

Table 14.c Test results for frequency stability

T°C	Voltage (V)	Frequency start	Freq after 30min	margin	Pass/Fail
25	nominal	914.948113	914.947312	801 (Hz)	pass

d. **Test Instrumentation and Equipment**

Table 14.d Test Instrumentation and Equipment

Item	Model	Manufacturer	Next Date Calibration
Spectrum Analyzer	8593E	HP	31.01.06

e. **Test Procedure**

**Test Procedure for frequency stability measurement**

- (1) The EUT was setup as shown in figure 14e
- (2) The carrier frequency was measured after the EUT was powered on and than after 10 minutes

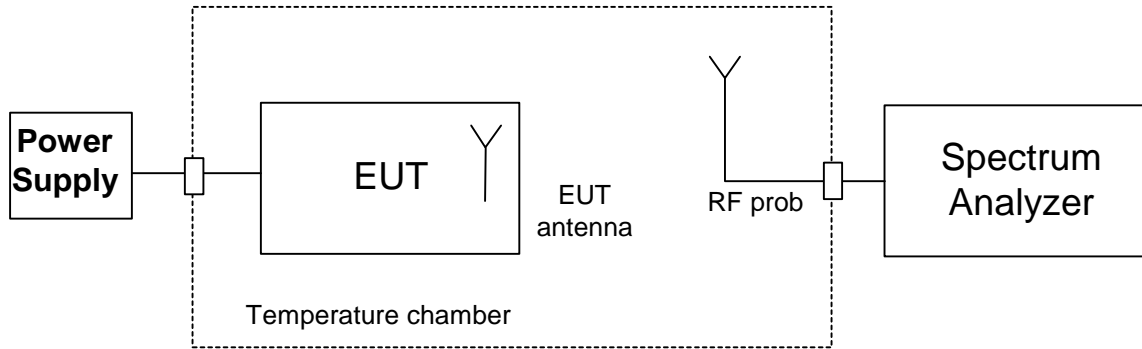



Figure 14e

Test setup t

**15 Radiated emission part 15.109**

E.U.T: FP-200SAG S/N: 002  
 Test Method: ANSI 63.4  
 Date: 01/09/05  
 Relative Humidity: 26%  
 Ambient Temperature: 22c  
 Air Pressure: 1047hpa  
 Test Setup: Figure 15.e

**Testing Engineer:** D.Lanuel



**Date** 15.09.05

**a. Test Results Summary & Conclusions**

The E.U.T was found in compliance unintentional radiated emission

**b. Limits of unintentional Radiated emission according 15.109**

**The test unit shall meet the limits of Table 15b.**

Table- 15b Limits For 15.109 Class B equipment 3m distance

Frequency Range (MHz)	Limits (dB $\mu$ V/m)	Detector
30 - 88	40	Quasi Peak
88 - 216	43.5	
216 - 960	46	
960 - 1000	46	
1000 - 2000	54	Average

**c. Test Instrumentation and Equipment**

Table- 15c Test Instrumentation and Equipment

Item	Model	Manufacturer	Next Date Calibration
Spectrum Analyzer	8593E	HP	31.01.06
Loop Antenna(10KHz-30MHz)	HFH 2-Z2	Rohde&Schwarz	N.P.C.R
Double Ridge Guide Ant(1-18GHz)	3105	EMCO	24.04.06
Broadband Antenna	BTA-L	FRANKONIA	10.04.06
Low Noise Amplifier (0-1GHz)	AM-1300-N	MITEQ	14.01.06
Low Noise Amplifier (1-4GHz)	AMM-003M	Avantek	14.01.06
Low Noise Amplifier (2-6GHz)	MWA-02060	ELISRA	14.01.06

**d. Results**
**Table- 15d** Preliminary Test Results for unintentional Emissions  
15.109

Mode of operation	Antenna Polarization	Freq. Range MHz	Res. BW (kHz)	Plot No.	Pass/Fail
Receive	Both	30-1000	120	Plot-54	Pass
		1,000-2.800	1000	Plot-55	Pass
		2.800-6,000	1000	Plot-56	Pass
Stby	Both	30-1000	120	Plot-57	Pass
		1,000-2.800	1000	Plot-58	Pass
		2.800-6,000	1000	Plot-59	Pass

Table 15d1 Final test results Six Highest Peak Emission

Freq. (MHz)	Antenna Pol.	Antenna Height (m)	Reading (dB $\mu$ V/m)	Limit dB $\mu$ V/m	Margin (dB)	Pass / Fail
The emission at least 30db below the carrier						

**e. Test Procedure**

(1) Preliminary Test Procedure

- a) The EUT was placed on the top of a rotating table 0.8 meters above the ground at a chamber shielded
- b) The E.U.T was set 3 meters away from the receiving antenna, which was mounted on the top of a variable-height antenna tower.
- c) The Antenna height varied from one meter to 1.8 meters above the ground and the table was rotated 360°to determine the maximum value of the field strength
- d) The antenna was set both horizontal and vertical polarization.
- e)  $\Delta$ The measurement were taken after selecting the EUT axis for maximum emission

(2) Final Test Procedure

- a) The EUT was tested at open area for each suspected emission,
- b) The test procedure was performed according paragraph e. but the Antenna height varied from one meter to four meters above the ground

**f. Final Test Setup**

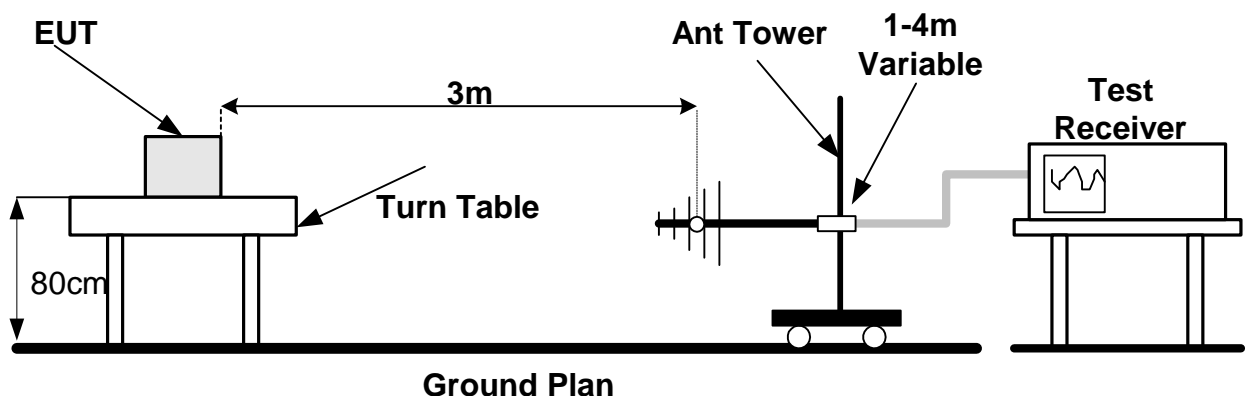

Figure- 15e Radiated Emission Test Configuration

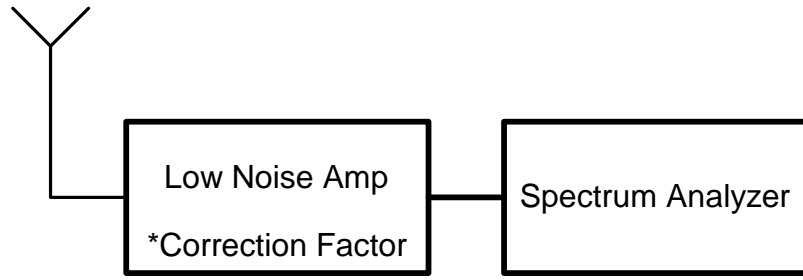
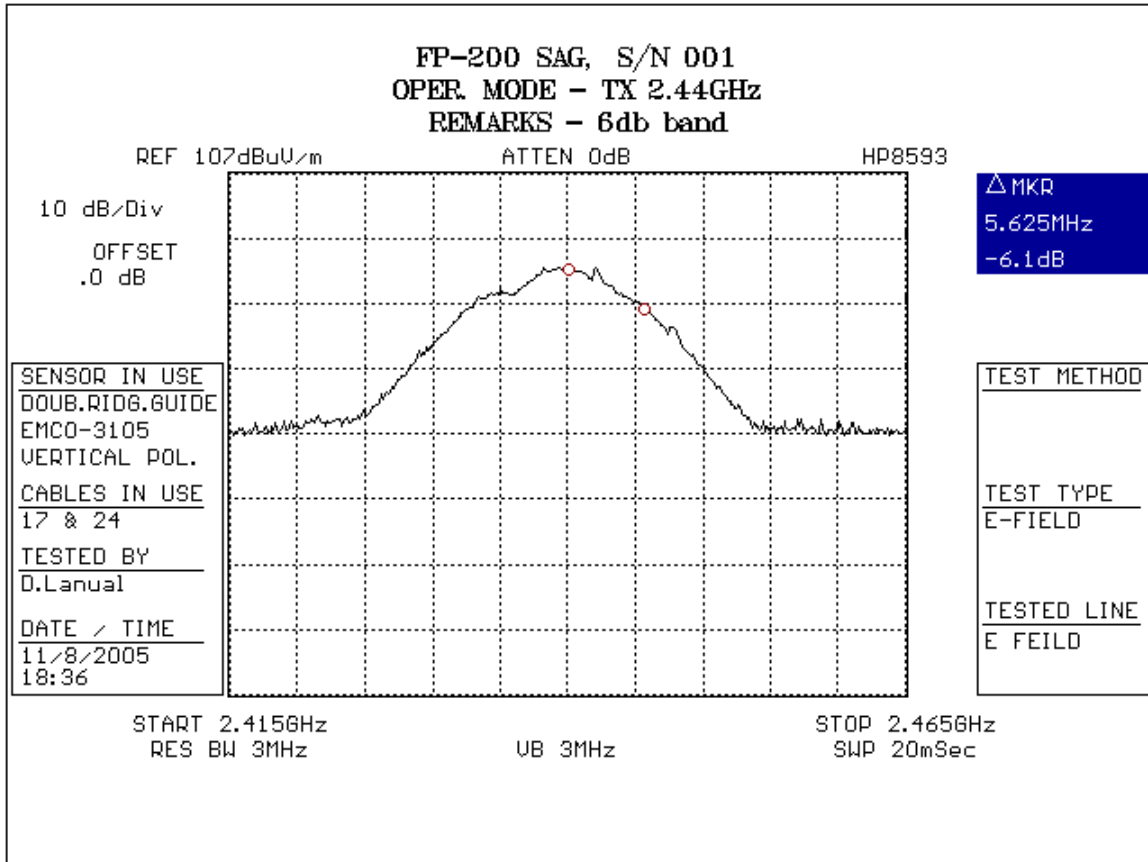

Figure- 15e1

Radiated Emission test 9 KHz – 10GHz

**16 Plots**

Plot No 1 Bandwidth test results



Plot No 2 Bandwidth test results

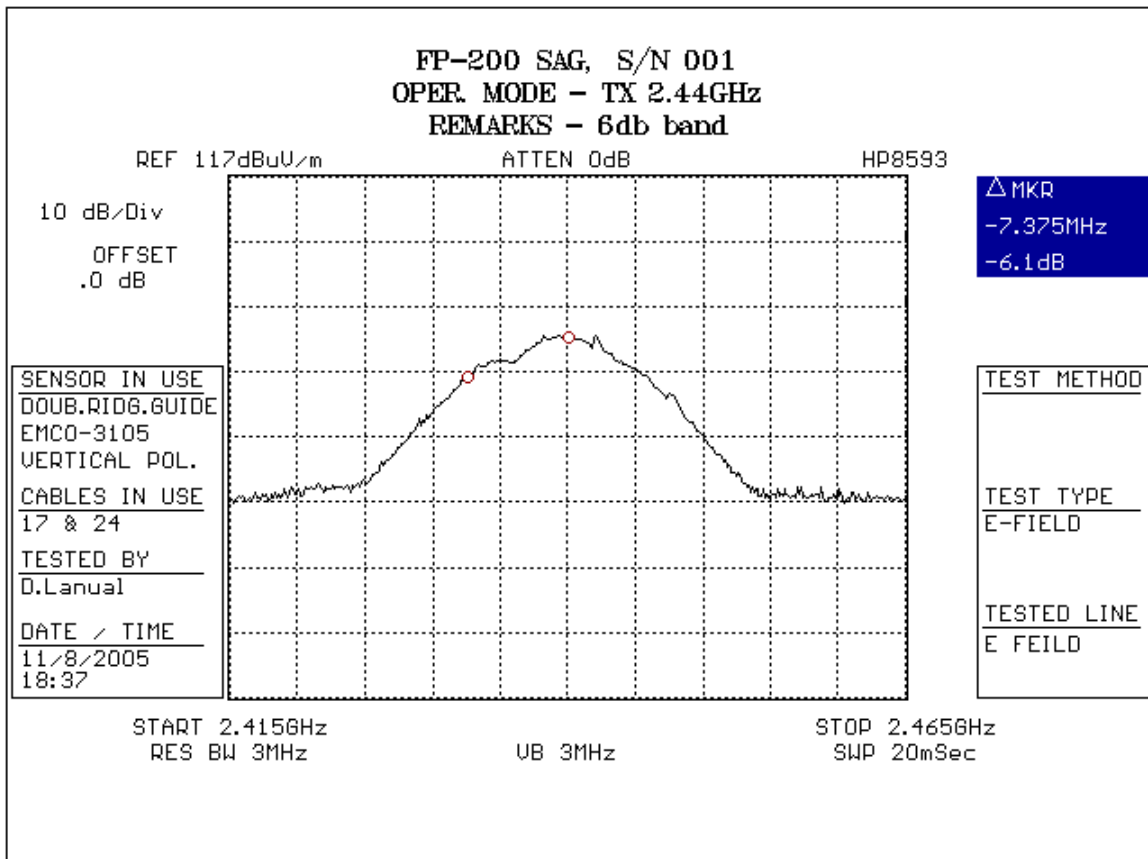

Test Results Plot No 3  
**FCC 15.247 peak power 2.4GHz**

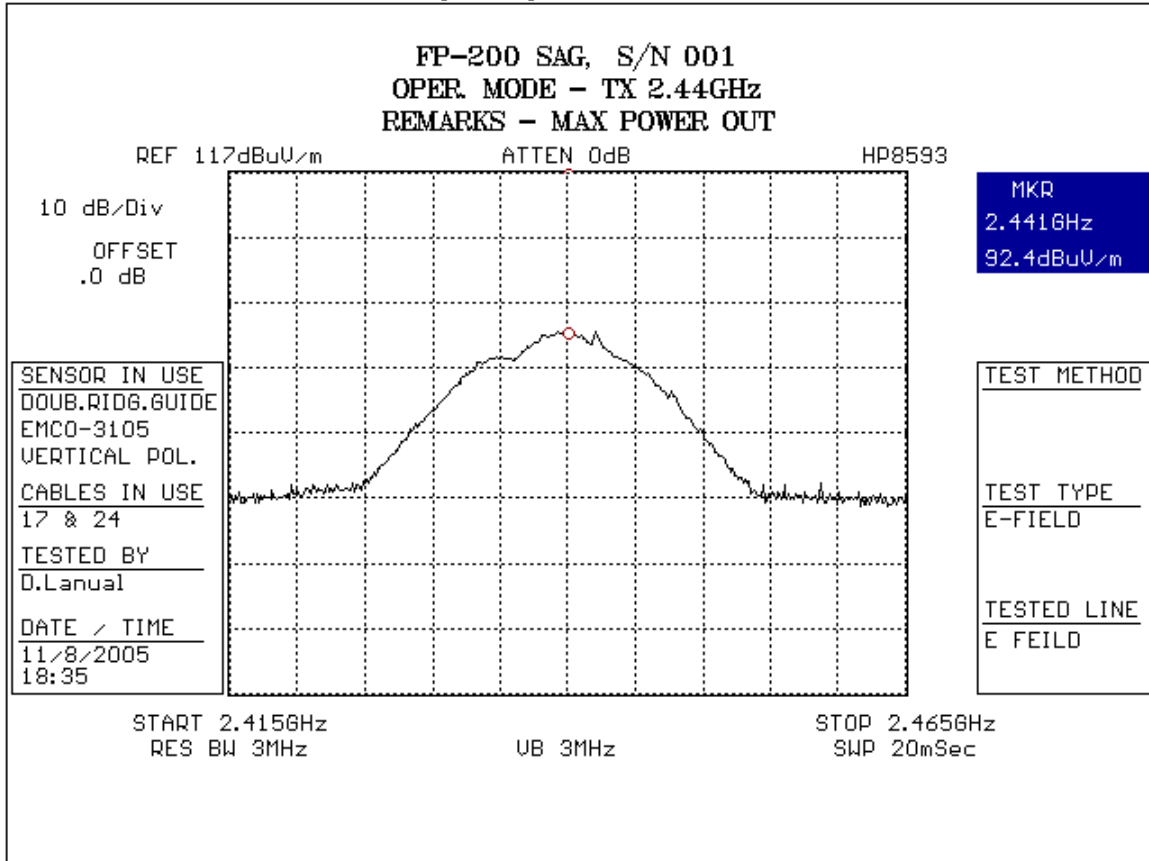

**MAXIMUM RESULT DEVIATION:**

Detect all peaks above 6 dB below the limit line with a maximum of 6 peaks.

Freq (MHz)	PK Max Hold (dBμV/m)	PK Limit dBμV/m	Result	Angle (degr)	Height (m)	H/V
2440.449	92.4	125.2	Pass	120	1	V



Test Results Plot No 4

**FCC 15.247 out of band at carrier frequency**

Test & EUT General Information		Receiver Setting	
EUT Name:	FP-200 SAG	Spect Analyzer	S.A HP 8593E
S/N:	002	Ref. Level:	132 dB $\mu$ V
Date of Test:		RBW:	100 kHz
Test Engineer:		VBW:	1000 kHz
Antenna:	ARA DRG-118/A 1-18GHz 1319	Sweep Time:	Auto: 20 ms
Polarization:	Vertical	Pre Amplifier	No Description Available

TEST REMARKS:

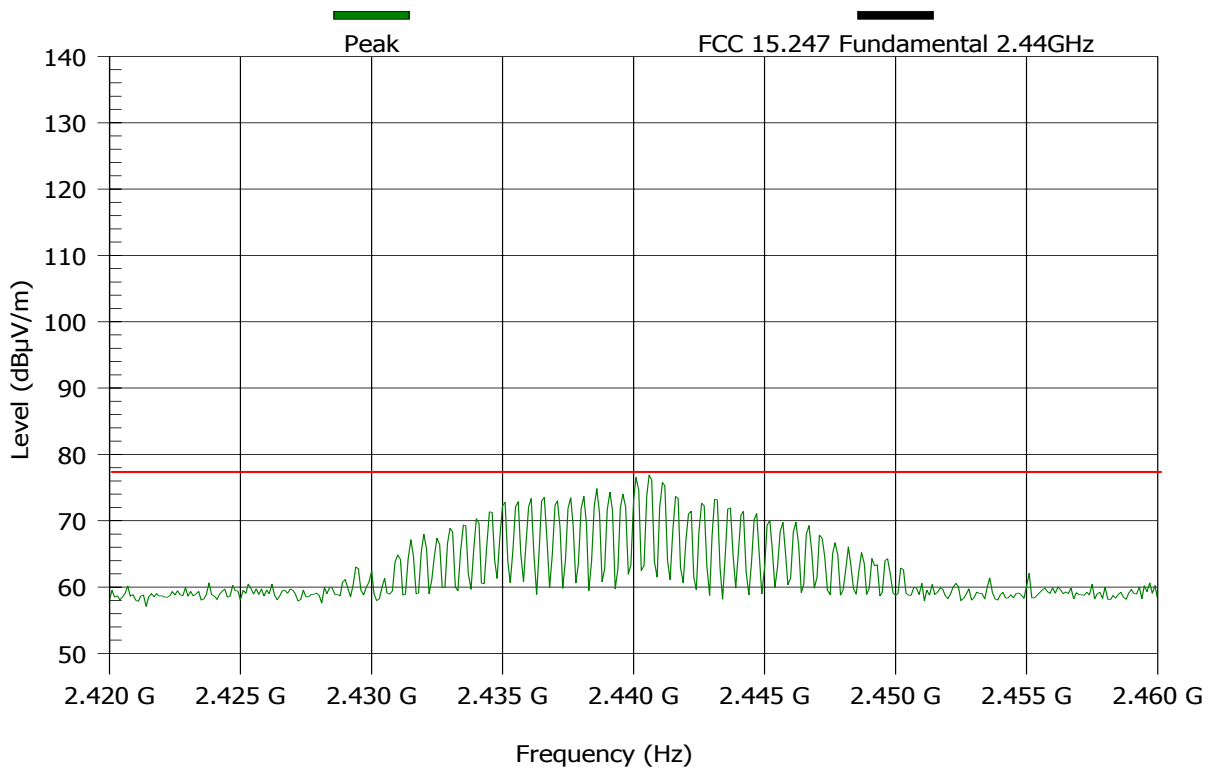

MAXIMUM RESULT DEVIATION:

Detect all peaks above 6 dB below the limit line with a maximum of 6 peaks.

Freq (MHz)	Peak dB $\mu$ V/m	Pk Limit dB $\mu$ V/m	Result	Angle (degr)	Height (m)	H/V
2440.449	77.5		Pass	120	1	V

Test Results Plot No 5  
**FCC 15.247 out of band 30-1000MHz**

Test & EUT General Information		Receiver Setting	
EUT Name:	FP-200 SAG	Spect Analyzer	S.A HP 8593E
S/N:	002	Ref. Level:	90 dB $\mu$ V
Date of Test:		RBW:	100 kHz
Test Engineer:		VBW:	1000 kHz
Antenna:	Frankonia BTA-L_A 3m	Sweep Time:	5 s
Polarization:	Horizontal and Vertical	Pre Amplifier	LNA MITEQ 0.01-1GHz No-1

TEST REMARKS:

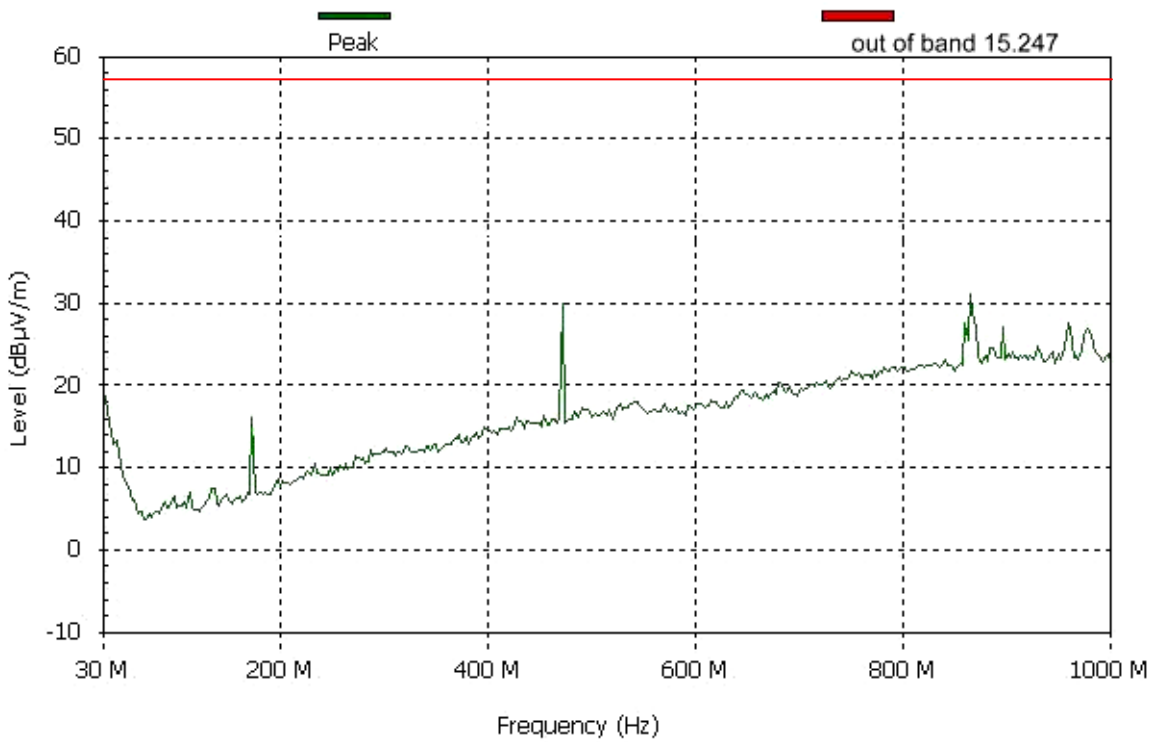

Test Results Plot No 6  
**FCC 15.247 OUT OF BABAND 1-2.8GHz**

Test & EUT General Information		Receiver Setting	
EUT Name:	FP-200 SAG	Spect Analyzer	S.A HP 8593E
S/N:	002	Ref. Level:	90 dB $\mu$ V
Date of Test:		RBW:	100 kHz
Test Engineer:		VBW:	1000 kHz
Antenna:	ARA DRG-118A 1-18GHz SER 1317	Sweep Time:	Auto: 540 ms
Polarization:	Horizontal and Vertical	Pre Amplifier	AVANTEK 1-2GHz

TEST REMARKS:

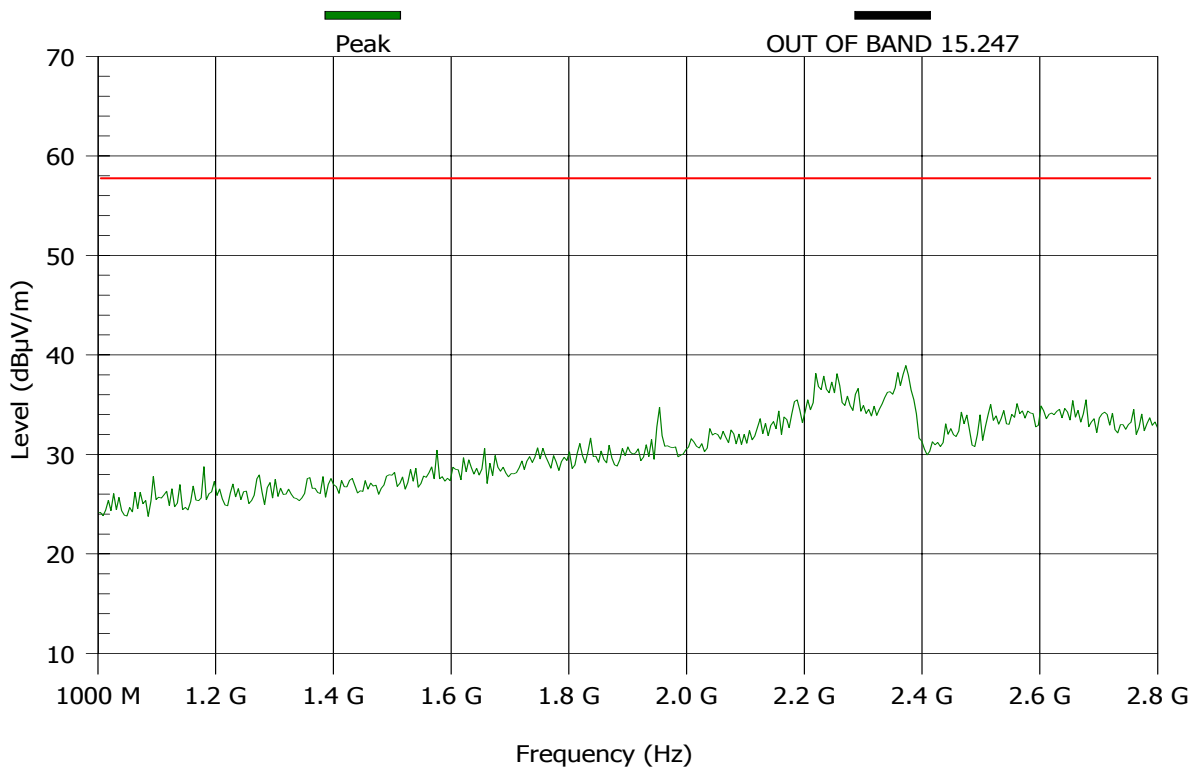

Test Results Plot No 7  
**FCC out of band 15.247 2.8-6GHz**

Test & EUT General Information		Receiver Setting	
EUT Name:	FP-200 SAG	Spect Analyzer	S.A HP 8593E
S/N:	002	Ref. Level:	90 dB $\mu$ V
Date of Test:		RBW:	100 kHz
Test Engineer:		VBW:	1000 kHz
Antenna:	ARA DRG-118A 1-18GHz SER 1317	Sweep Time:	Auto: 960 ms
Polarization:	Horizontal and Vertical	Pre Amplifier	ELISRA AMP 2-6 GHz

TEST REMARKS:

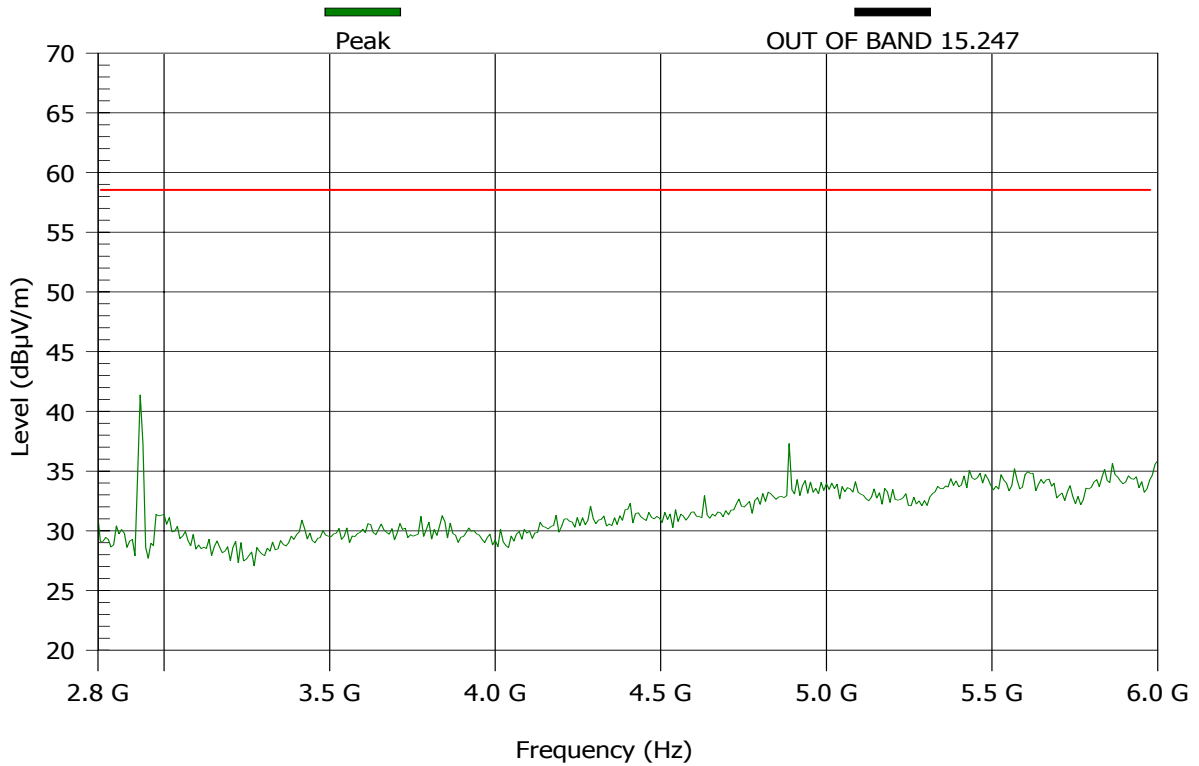

Test Results Plot No 8  
**FCC 15.247 6-10GHz OUT OF BAND**

Test & EUT General Information		Receiver Setting	
EUT Name:	FP-200 SAG	Spect Analyzer	S.A HP 8593E
S/N:	002	Ref. Level:	90 dB $\mu$ V
Date of Test:		RBW:	100 kHz
Test Engineer:		VBW:	1000 kHz
Antenna:	ARA DRG-118A 1-18GHz SER 1317	Sweep Time:	Auto: 1.2 s
Polarization:	Horizontal and Vertical	Pre Amplifier	ELISRA AMP 6-18 GHz

TEST REMARKS:

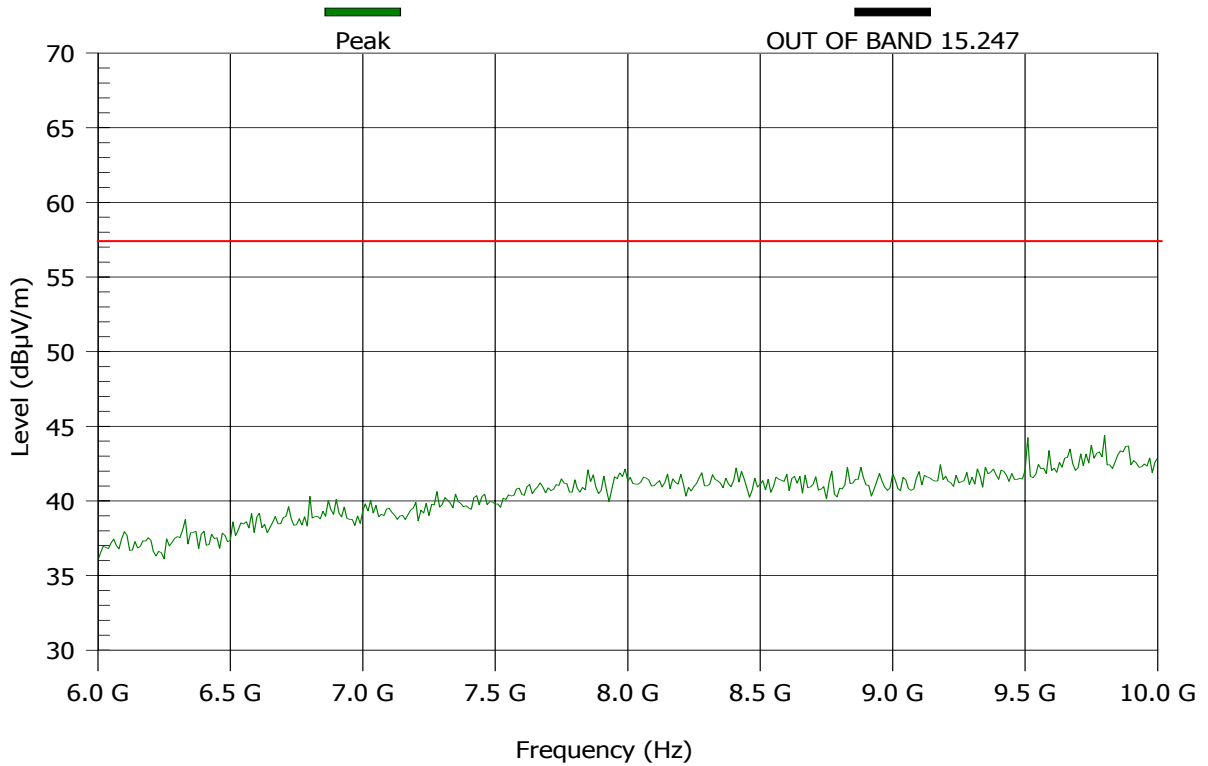

Test Results Plot No 9  
**FCC 15.247 10-18GHz OUT OF BAND**

Test & EUT General Information		Receiver Setting	
EUT Name:	FP-200 SAG	Spect Analyzer	S.A HP 8593E
S/N:	002	Ref. Level:	90 dB $\mu$ V
Date of Test:		RBW:	100 kHz
Test Engineer:		VBW:	1000 kHz
Antenna:	ARA DRG-118A 1-18GHz SER 1317	Sweep Time:	Auto: 2.4 s
Polarization:	Horizontal and Vertical	Pre Amplifier	ELISRA AMP 6-18 GHz

TEST REMARKS:

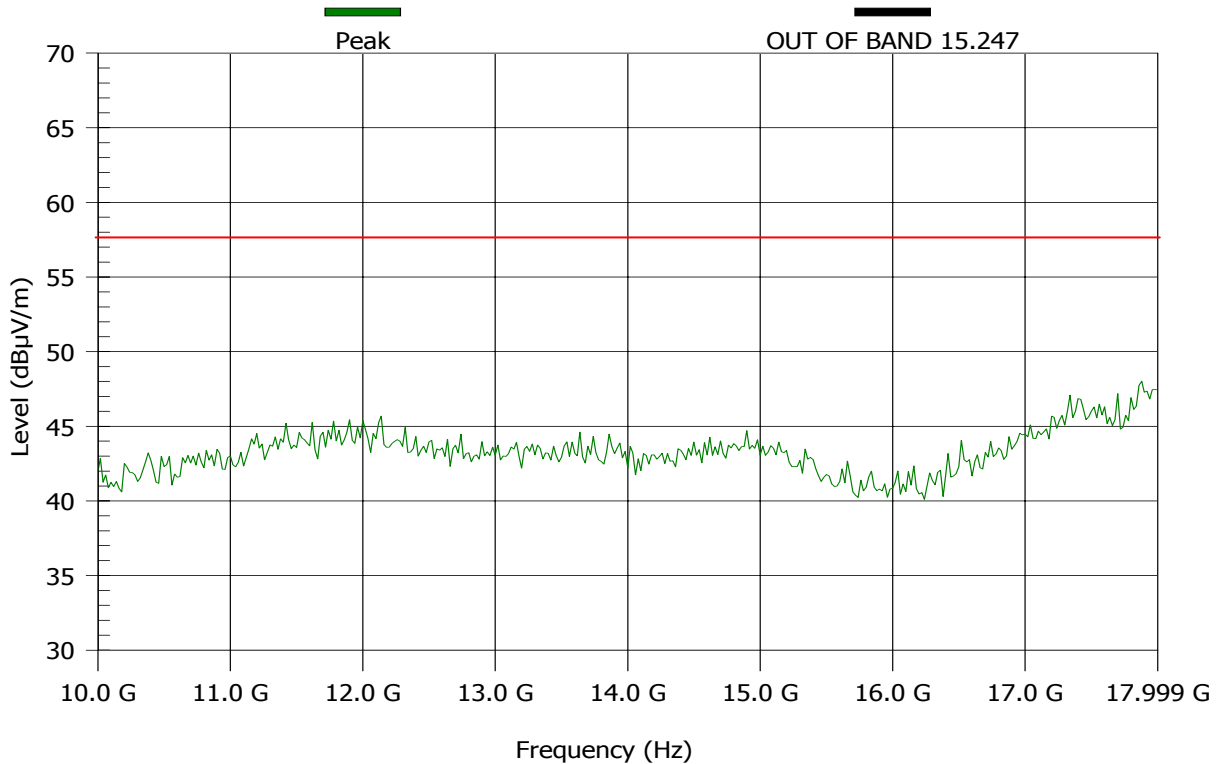

Test Results Plot No 10  
**FCC 15.205 RESTRICTED 0.009-0.15MHz ver**

Test & EUT General Information		Receiver Setting	
EUT Name:	FP-200 SAG	Spect Analyzer	S.A HP 8593E
S/N:	002	Ref. Level:	90 dB $\mu$ V
Date of Test:		RBW:	1000 Hz
Test Engineer:		VBW:	1000 kHz
Antenna:	LOOP ANT.HFH 2 Z2	Sweep Time:	Auto: 423 ms
Polarization:	Vertical	Pre Amplifier	No Description Available

TEST REMARKS:

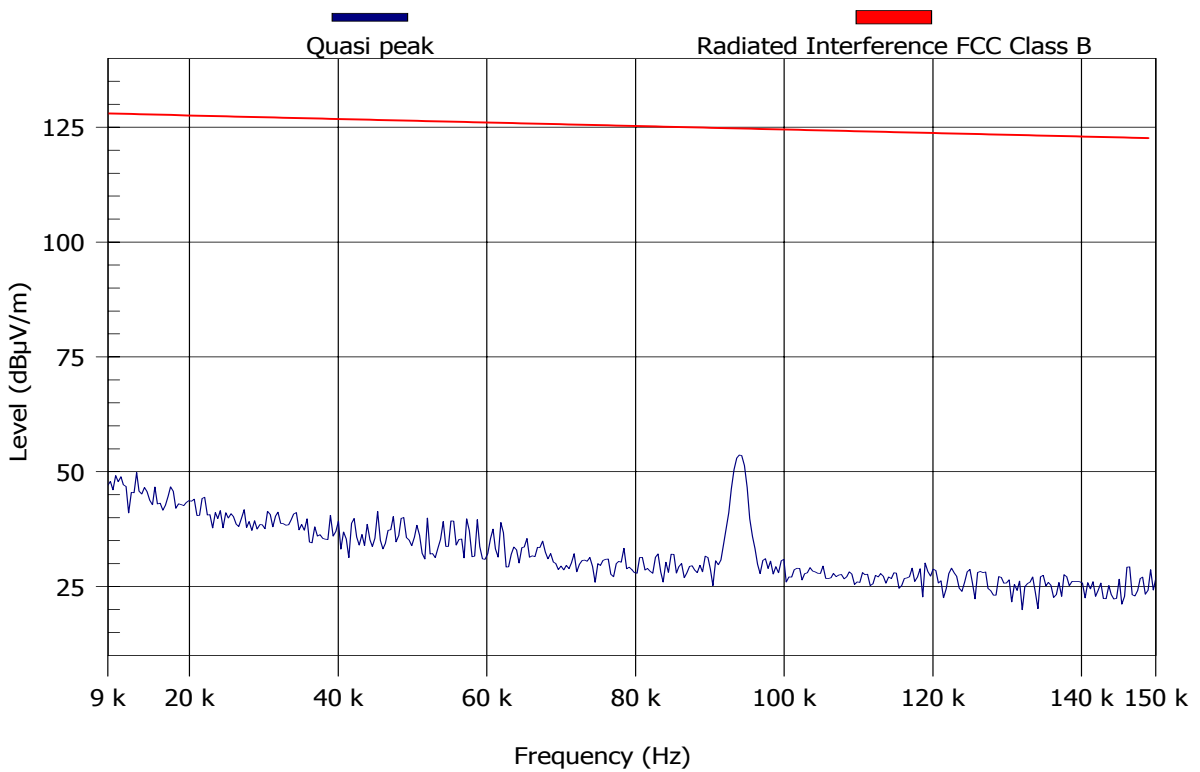

MAXIMUM RESULT DEVIATION:

Detect all peaks above 6 dB below the limit line with a maximum of 6 peaks.  
None

Test Results Plot No 11  
**FCC 15.205 RESTRICTED 0.009-0.15MHz HOR**

Test & EUT General Information		Receiver Setting	
EUT Name:	FP-200 SAG	Spect Analyzer	S.A HP 8593E
S/N:	002	Ref. Level:	90 dB $\mu$ V
Date of Test:		RBW:	1000 Hz
Test Engineer:		VBW:	1000 kHz
Antenna:	LOOP ANT.HFH 2 Z2	Sweep Time:	Auto: 423 ms
Polarization:	Horizontal	Pre Amplifier	No Description Available

TEST REMARKS:

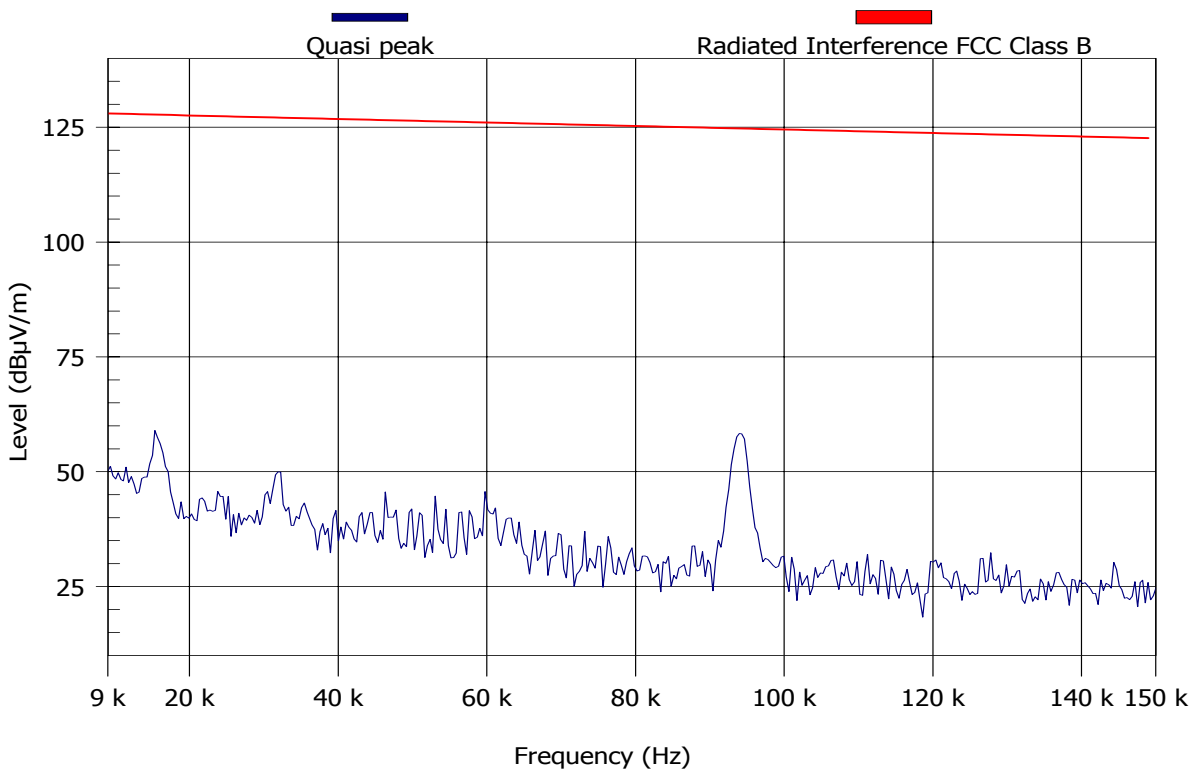

MAXIMUM RESULT DEVIATION:

Detect all peaks above 6 dB below the limit line with a maximum of 6 peaks.  
None



Test Results Plot No 12  
**FCC 15.205 RESTRICTED 0.15-30MHz ver**

Test & EUT General Information		Receiver Setting	
EUT Name:	FP-200 SAG	Spect Analyzer	S.A HP 8593E
S/N:	002	Ref. Level:	90 dB $\mu$ V
Date of Test:		RBW:	9 kHz
Test Engineer:		VBW:	1000 kHz
Antenna:	LOOP ANT.HFH 2 Z2	Sweep Time:	Auto: 1.11 s
Polarization:	Vertical	Pre Amplifier	No Description Available

TEST REMARKS:

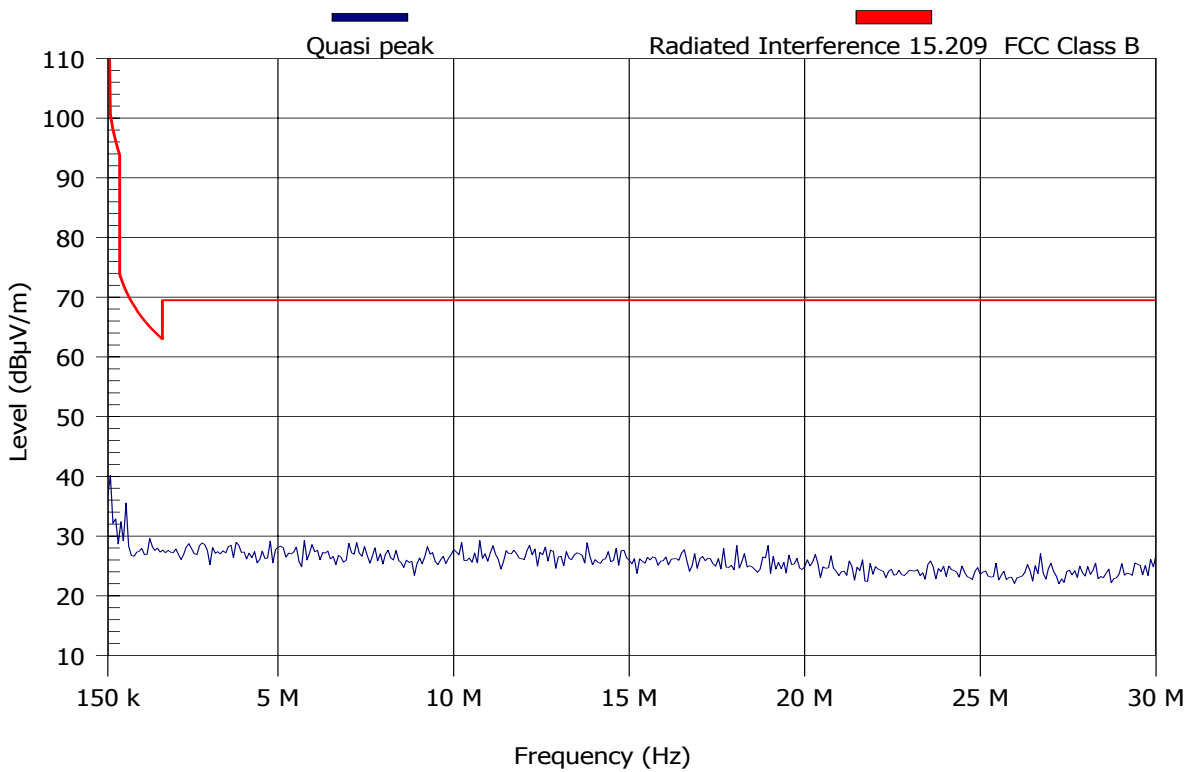

MAXIMUM RESULT DEVIATION:

Detect all peaks above 6 dB below the limit line with a maximum of 6 peaks.  
None

Test Results Plot No 13  
**FCC 15.205 RESTRICTED 0.15-30MHz hour**

Test & EUT General Information		Receiver Setting	
EUT Name:	FP-200 SAG	Spect Analyzer	S.A HP 8593E
S/N:	002	Ref. Level:	90 dB $\mu$ V
Date of Test:		RBW:	9 kHz
Test Engineer:		VBW:	1000 kHz
Antenna:	LOOP ANT.HFH 2 Z2	Sweep Time:	Auto: 1.11 s
Polarization:	Horizontal	Pre Amplifier	No Description Available

TEST REMARKS:

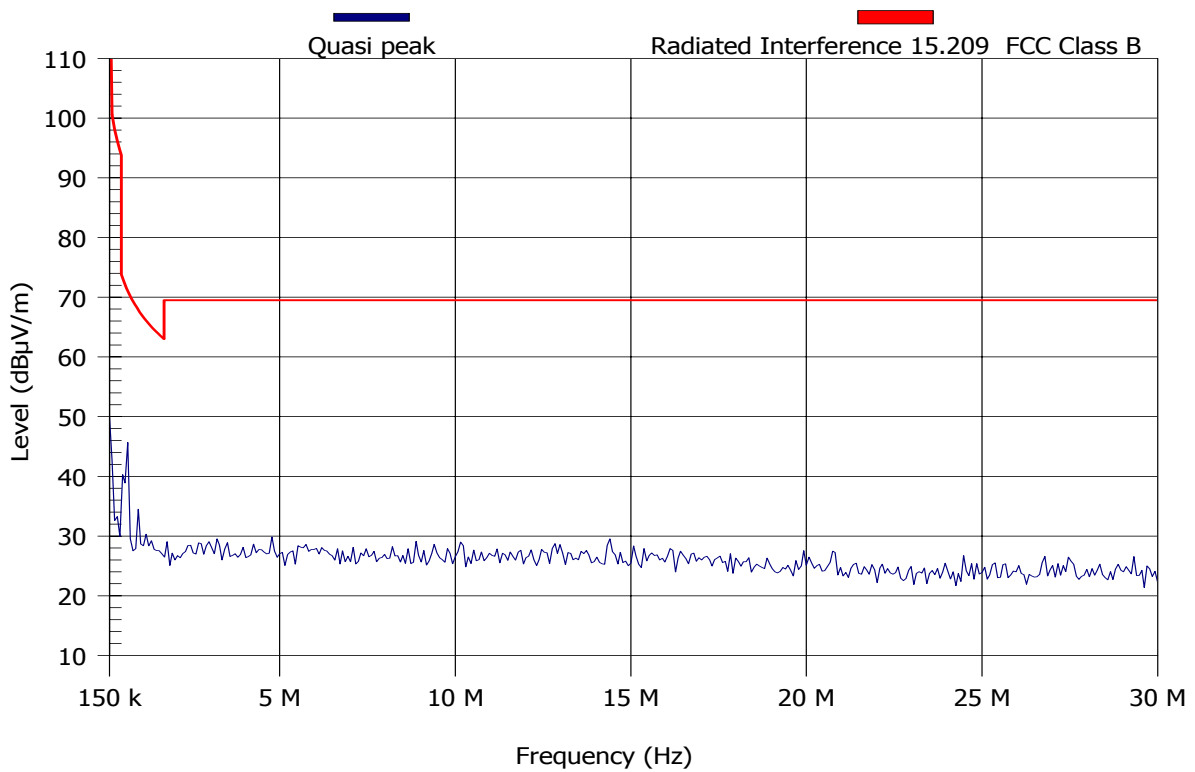

MAXIMUM RESULT DEVIATION:

Detect all peaks above 6 dB below the limit line with a maximum of 6 peaks.  
None

Test Results Plot No 14  
**FCC 15.205 RESTRICTED 30-1000MHz**

Test & EUT General Information		Receiver Setting	
EUT Name:	FP-200 SAG	Spect Analyzer	S.A HP 8593E
S/N:	002	Ref. Level:	90 dBµV
Date of Test:		RBW:	120 kHz
Test Engineer:		VBW:	1000 kHz
Antenna:	Frankonia BTA-L_A 3m	Sweep Time:	Auto: 202.08 ms
Polarization:	Vertical	Pre Amplifier	LNA MITEQ 0.01-1GHz No-3

TEST REMARKS:

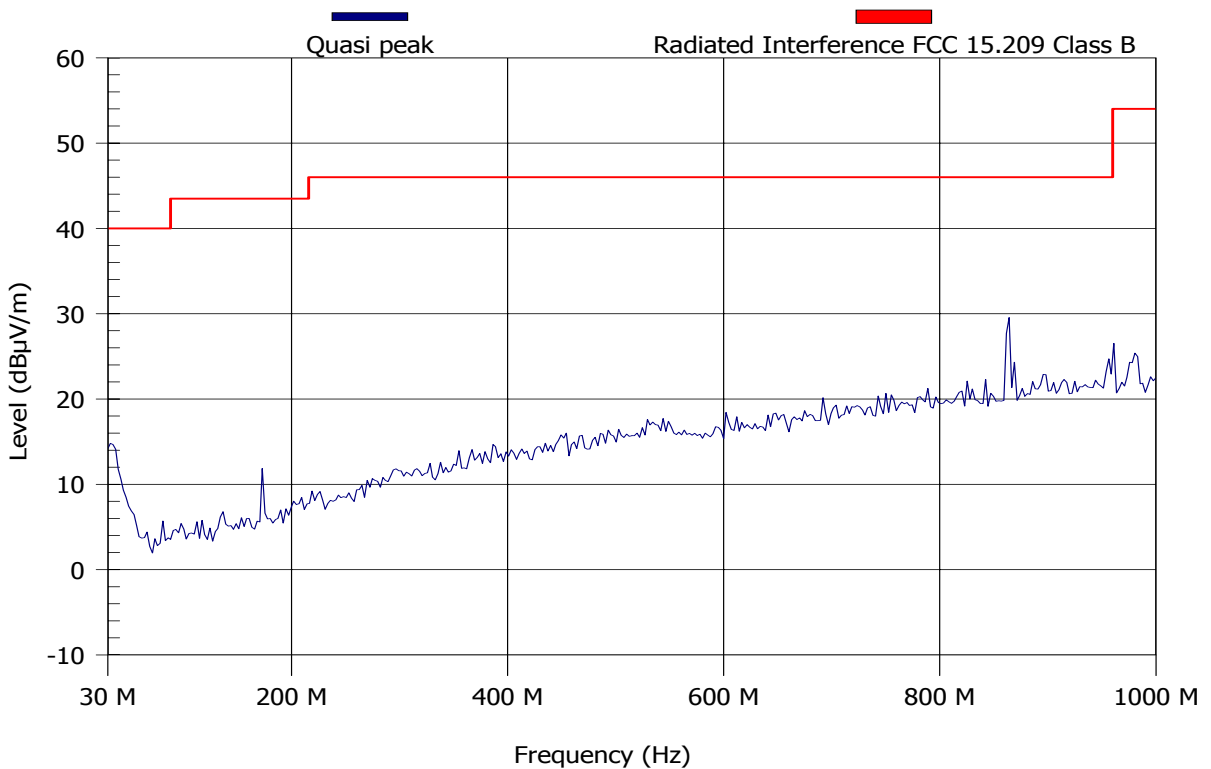

MAXIMUM RESULT DEVIATION:

Detect all peaks above 6 dB below the limit line with a maximum of 6 peaks.

Freq (MHz)	QP (dBµV/m)	QP Limit (dBµV/m)	Result	Angle (degr)	Height (m)	H/V
859.98	29.4	46	Pass	120	1.3	V

Test Results Plot No 15

**FCC 15.209 1-2.8GHz restricted**

Test & EUT General Information		Receiver Setting	
EUT Name:	FP-200 SAG	Spect Analyzer	S.A HP 8593E
S/N:	002	Ref. Level:	90 dBμV
Date of Test:		RBW:	1000 kHz
Test Engineer:		VBW:	1000 kHz
Antenna:	ARA DRG-118A 1-18GHz SER 1317	Sweep Time:	Auto: 36 ms
Polarization:	Horizontal and Vertical	Pre Amplifier	pre amp 1GHz-4GHz

TEST REMARKS:

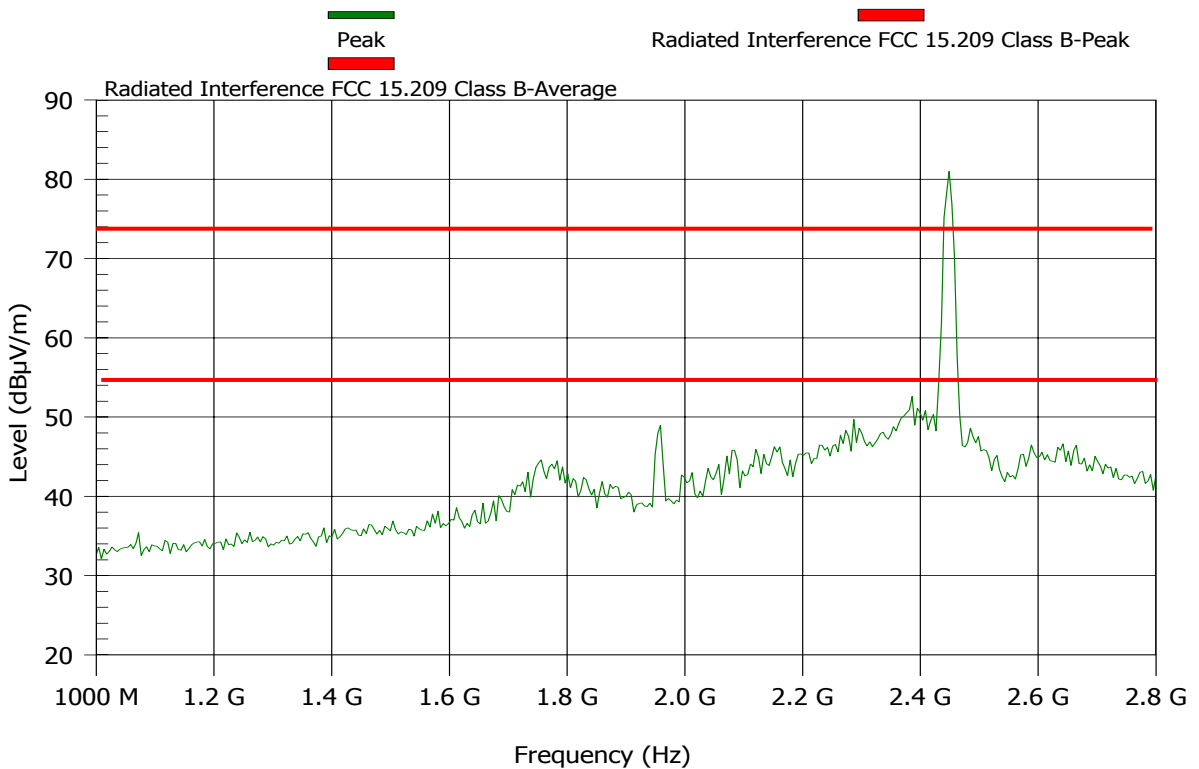

MAXIMUM RESULT DEVIATION:

Detect all peaks above 6 dB below the limit line with a maximum of 6 peaks.

Freq (MHz)	Peak (dBμV/m)	Pk Limit (dBμV/m)	Result	Angle (degr)	Height (m)	H/V
2410.765	81.6	NA	Pass	120	1	V

Test Results Plot No 16

**FCC 15.209 2.8-6GHz restricted**

Test & EUT General Information		Receiver Setting	
EUT Name:	FP-200 SAG	Spect Analyzer	S.A HP 8593E
S/N:	002	Ref. Level:	90 dBµV
Date of Test:		RBW:	1000 kHz
Test Engineer:		VBW:	1000 kHz
Antenna:	ARA DRG-118A 1-18GHz SER 1317	Sweep Time:	Auto: 64 ms
Polarization:	Horizontal and Vertical	Pre Amplifier	ELISRA AMP 6-18 GHz

TEST REMARKS:

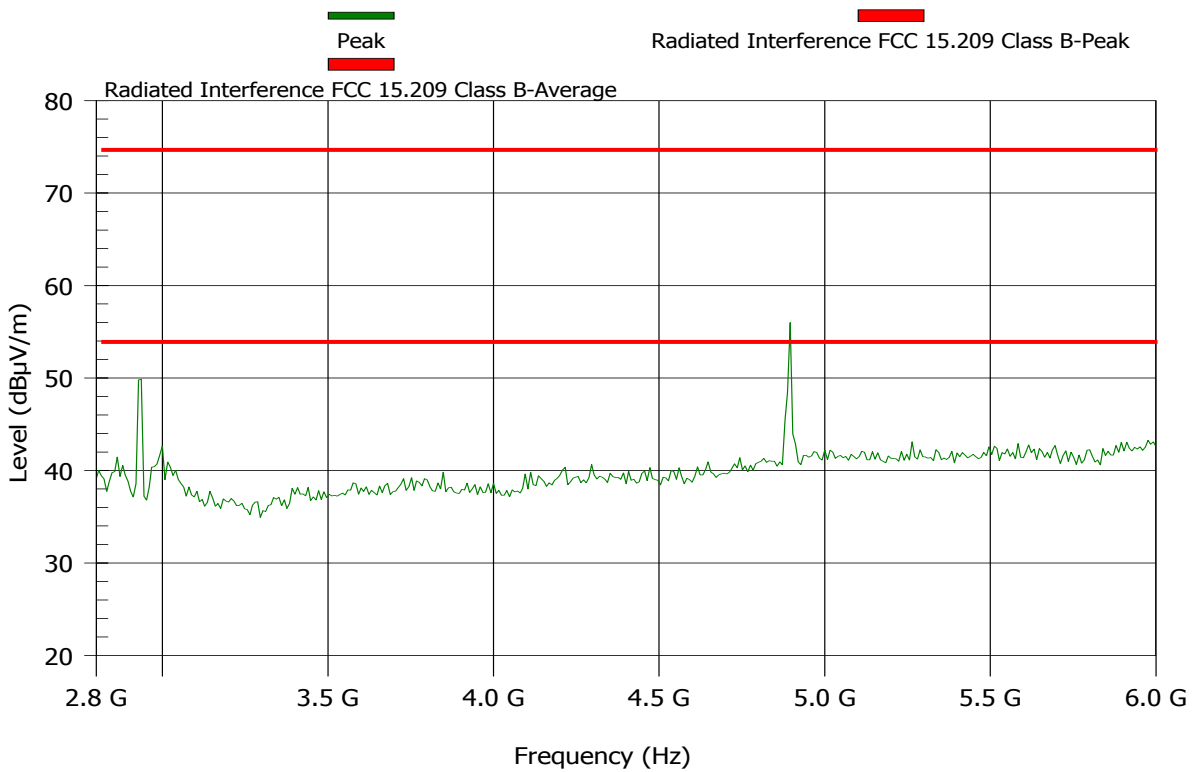

MAXIMUM RESULT DEVIATION:

Detect all peaks above 6 dB below the limit line with a maximum of 6 peaks.

Freq (MHz)	Peak (dBµV/m)	Pk Limit (dBµV/m)	Result	Angle (degr)	Height (m)	H/V
4881.123	57.1	74	Pass	120	1	V

Test Results Plot No 17  
**FCC 15.209 6-10GHz restricted**

Test & EUT General Information		Receiver Setting	
EUT Name:	FP-200 SAG	Spect Analyzer	S.A HP 8593E
S/N:	002	Ref. Level:	90 dB $\mu$ V
Date of Test:		RBW:	100 kHz
Test Engineer:		VBW:	1000 kHz
Antenna:	ARA DRG-118A 1-18GHz SER 1317	Sweep Time:	Auto: 89.83 ms
Polarization:	Horizontal and Vertical	Pre Amplifier	ELISRA AMP 6-18 GHz

TEST REMARKS:

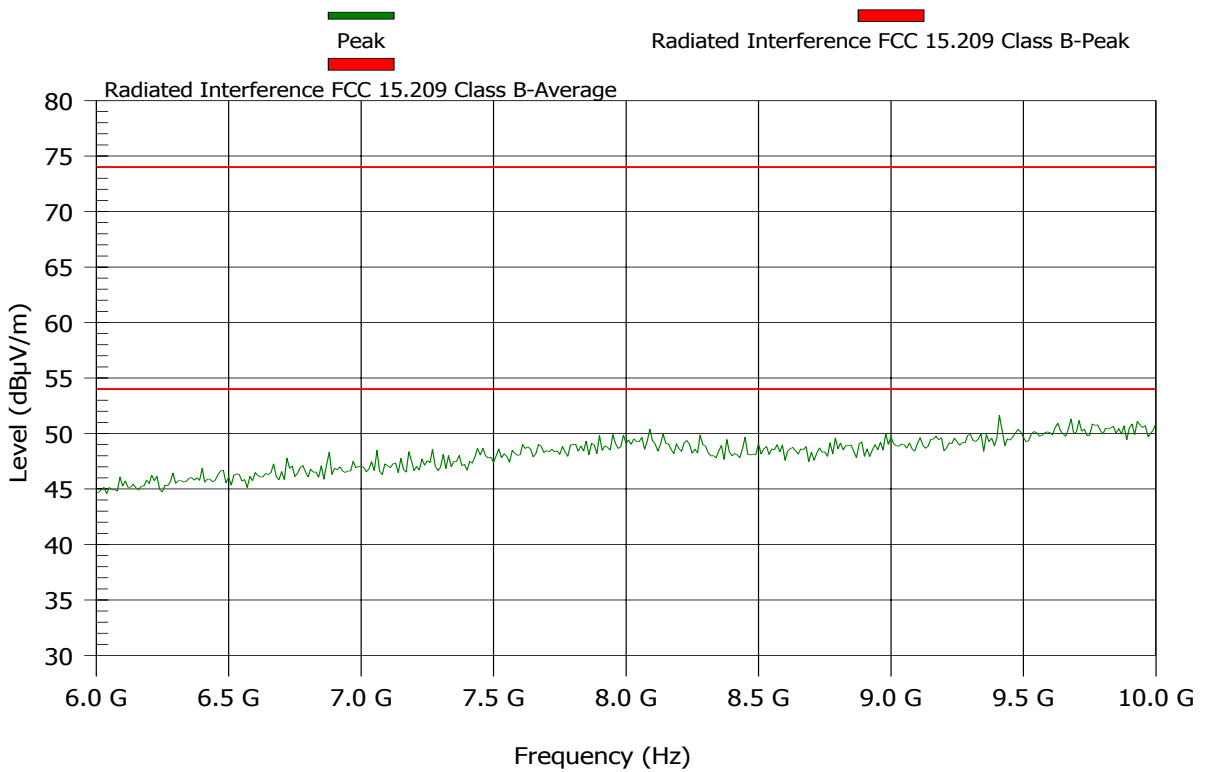

MAXIMUM RESULT DEVIATION:

Detect all peaks above 6 dB below the limit line with a maximum of 6 peaks.

Test Results Plot No 18  
**FCC 15.209 10-18GHz restricted**

Test & EUT General Information		Receiver Setting	
EUT Name:	FP-200 SAG	Spect Analyzer	S.A HP 8593E
S/N:	002	Ref. Level:	90 dB $\mu$ V
Date of Test:		RBW:	1000 kHz
Test Engineer:		VBW:	1000 kHz
Antenna:	ARA DRG-118A 1-18GHz SER 1317	Sweep Time:	Auto: 140 ms
Polarization:	Horizontal and Vertical	Pre Amplifier	ELISRA AMP 2-6 GHz

TEST REMARKS:

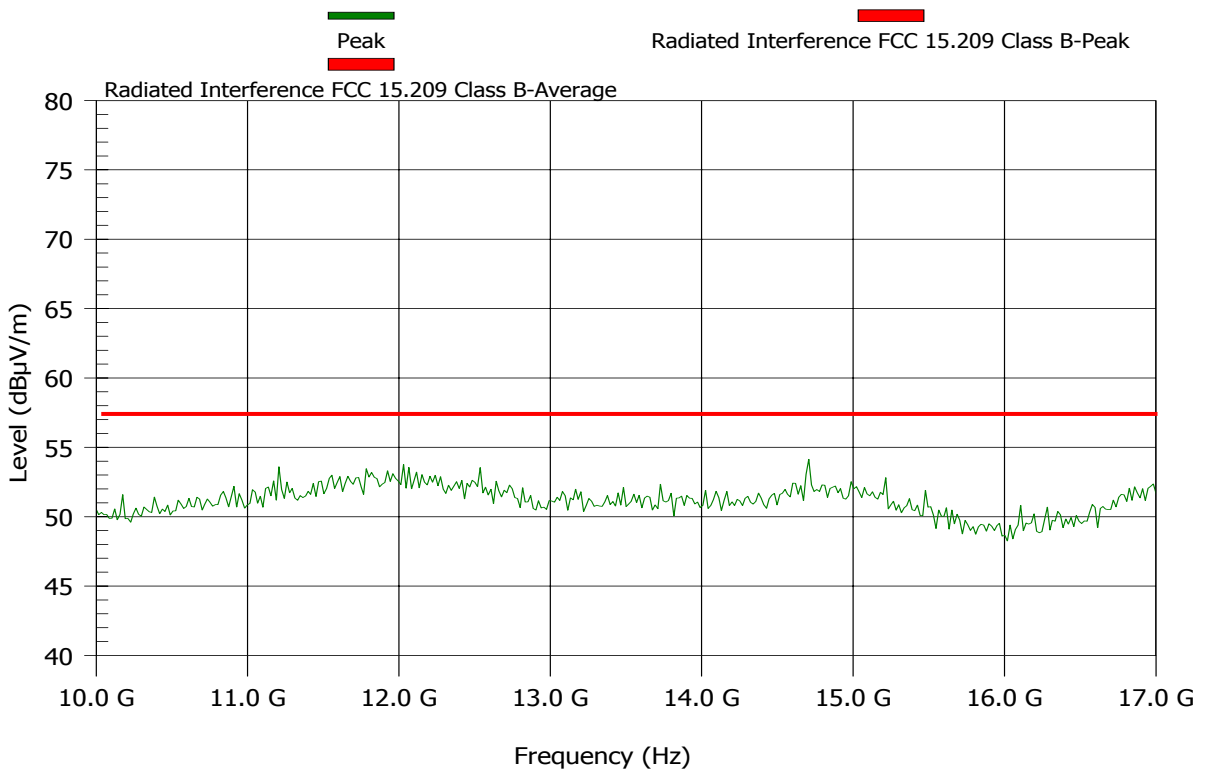

**MAXIMUM RESULT DEVIATION:**

Detect all peaks above 6 dB below the limit line with a maximum of 6 peaks.

Test Results Plot No 19  
**FCC 15.209 second harmonic average**

Test & EUT General Information		Receiver Setting	
EUT Name:	FP-200 SAG	Spect Analyzer	S.A HP 8593E
S/N:	002	Ref. Level:	90 dB $\mu$ V
Date of Test:		RBW:	1000 kHz
Test Engineer:		VBW:	10 Hz
Antenna:	ARA DRG-118A 1-18GHz SER 1317	Sweep Time:	Auto: 12 s
Polarization:	Horizontal and Vertical	Pre Amplifier	ELISRA AMP 6-18 GHz

TEST REMARKS:

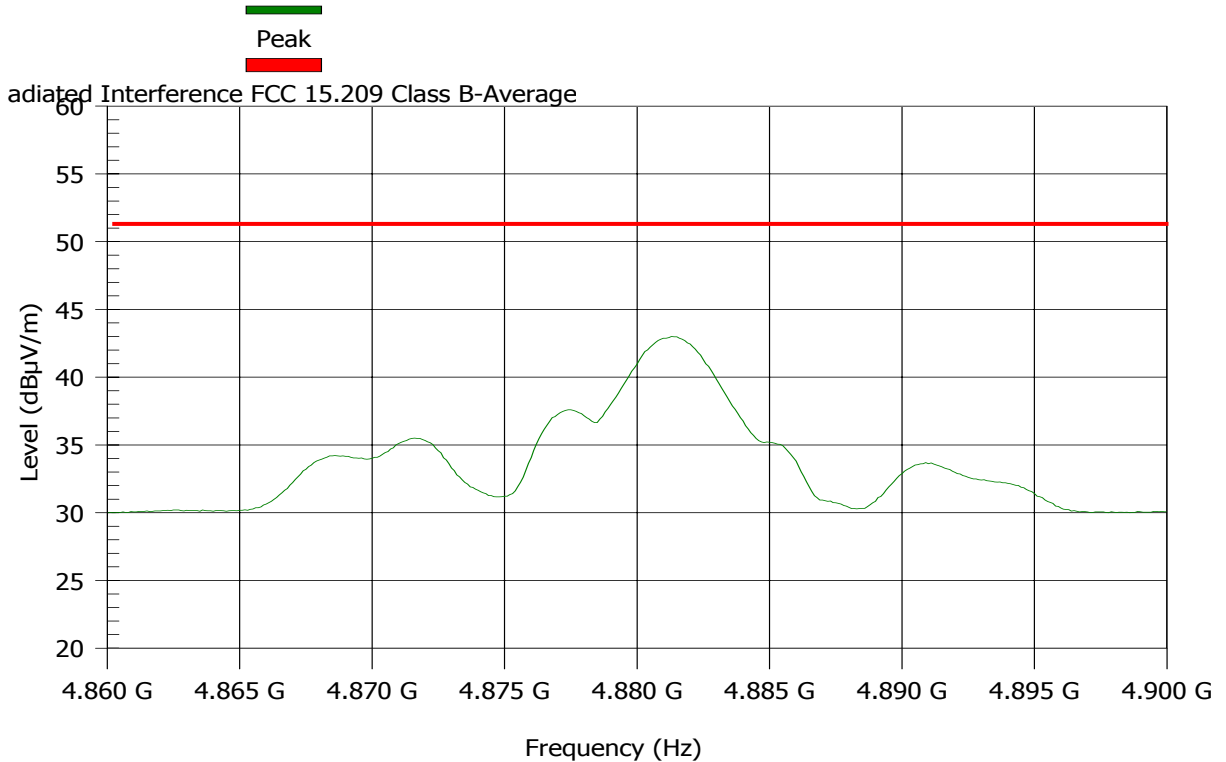

MAXIMUM RESULT DEVIATION:

Detect all peaks above 6 dB below the limit line with a maximum of 6 peaks.



Test Results Plot No 20  
**FCC 15.247d peak power spectral density**

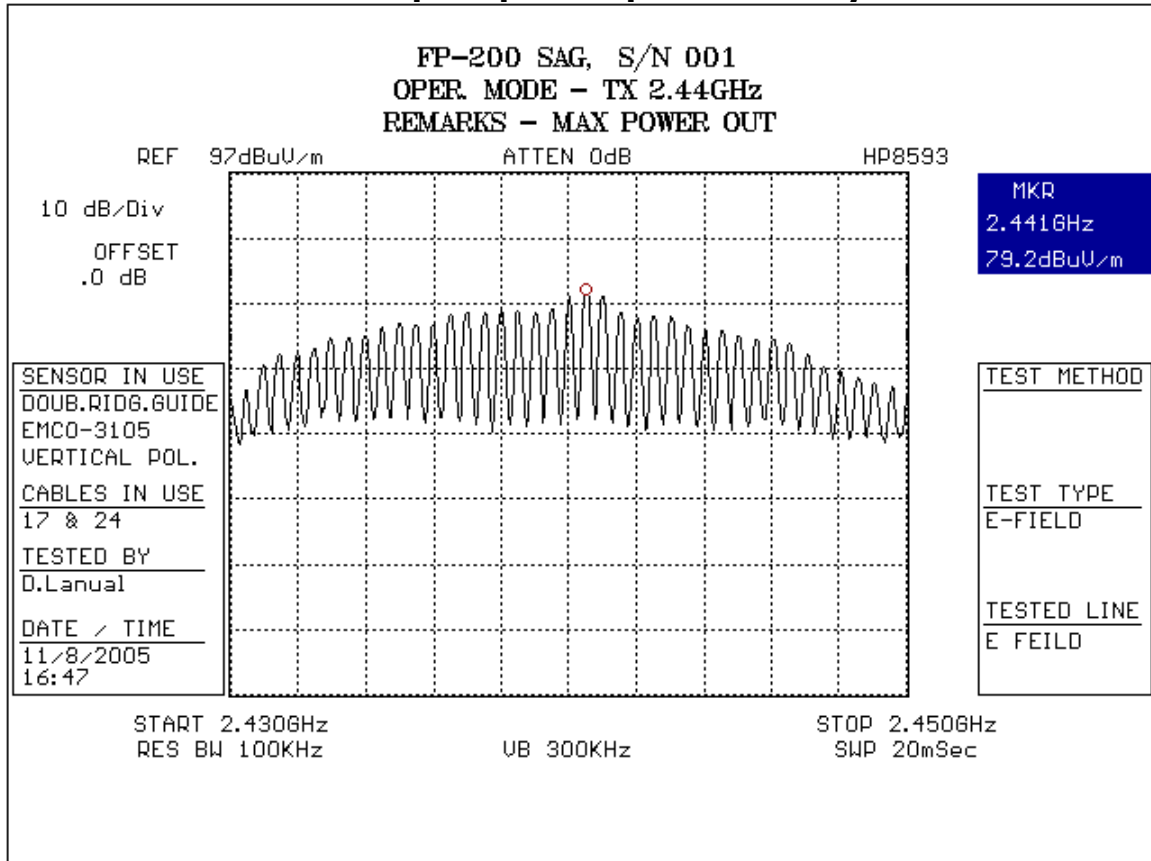

Test Results Plot No 21  
**FCC 15.247d peak power spectral density**

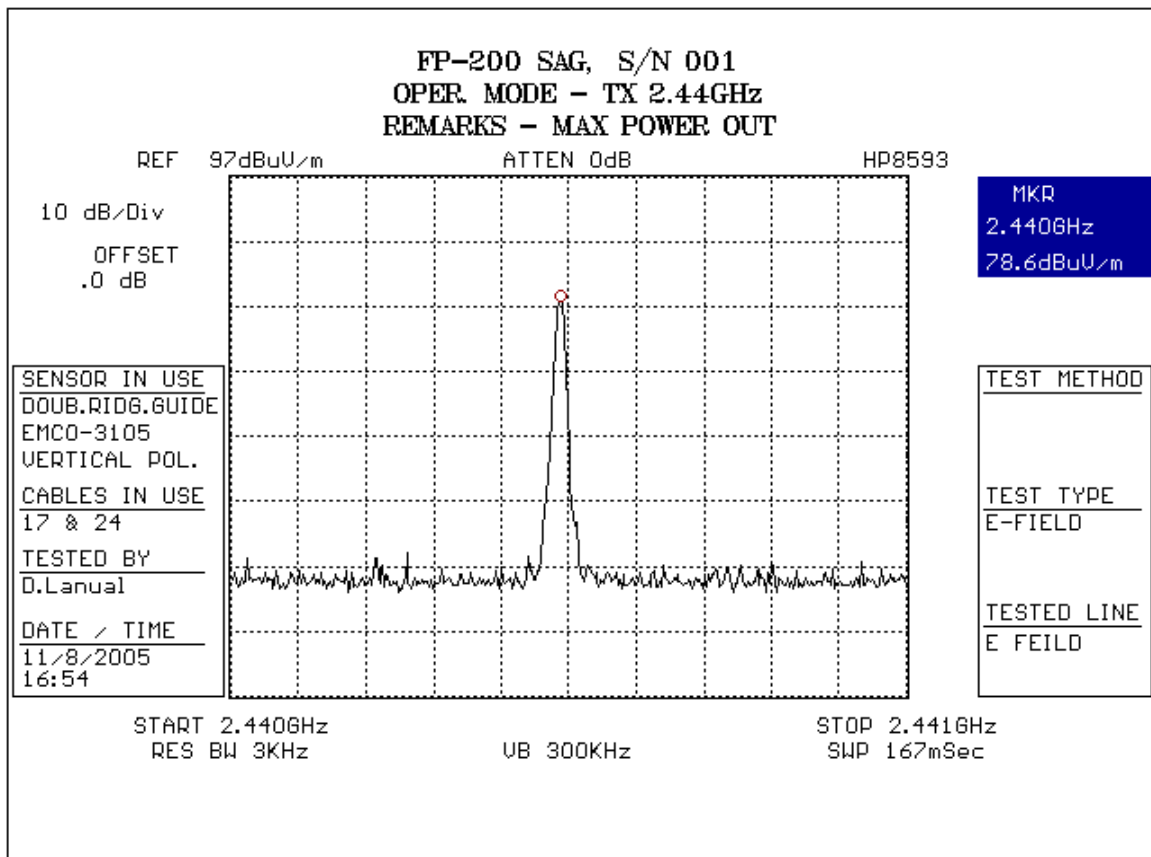

Test Results Plot No 22  
**FCC 15.109 30-1000MHz**

Test & EUT General Information		Receiver Setting	
EUT Name:	FP-200 SAG	Spect Analyzer	S.A HP 8593E
S/N:	002	Ref. Level:	90 dB $\mu$ V
Date of Test:		RBW:	120 kHz
Test Engineer:		VBW:	1000 kHz
Antenna:	Frankonia BTA-L_A 3m	Sweep Time:	5 s
Polarization:	Horizontal and Vertical	Pre Amplifier	LNA 29db 0.01-1GHz No-1

TEST REMARKS:

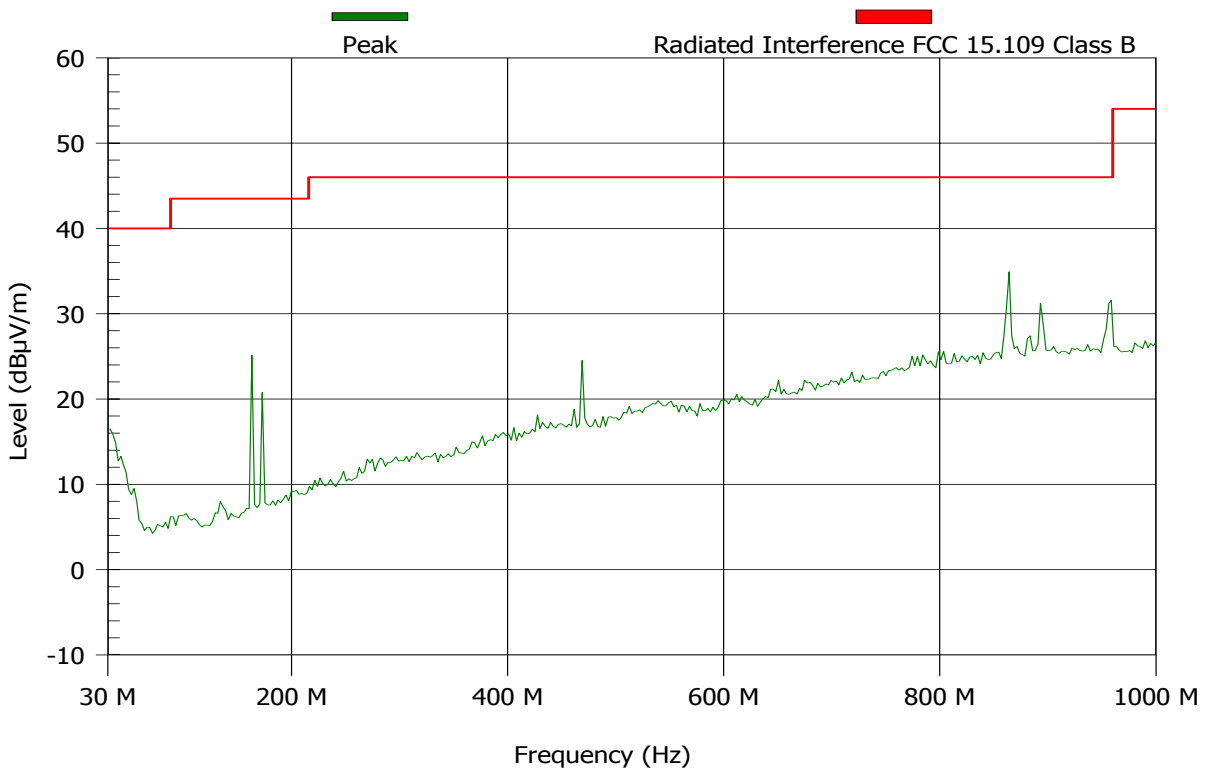

MAXIMUM RESULT DEVIATION:

Detect all peaks above 6 dB below the limit line with a maximum of 6 peaks.

None

Test Results Plot No 23  
**FCC 15.109 1-2.8GHz**

Test & EUT General Information		Receiver Setting	
EUT Name:	FP-200 SAG	Spect Analyzer	S.A HP 8593E
S/N:	002	Ref. Level:	90 dB $\mu$ V
Date of Test:		RBW:	1000 kHz
Test Engineer:		VBW:	1000 kHz
Antenna:	ARA DRG-118/A 1-18GHz 1319	Sweep Time:	Auto: 36 ms
Polarization:	Horizontal and Vertical	Pre Amplifier	LNA 27db 1-4GHz

TEST REMARKS:

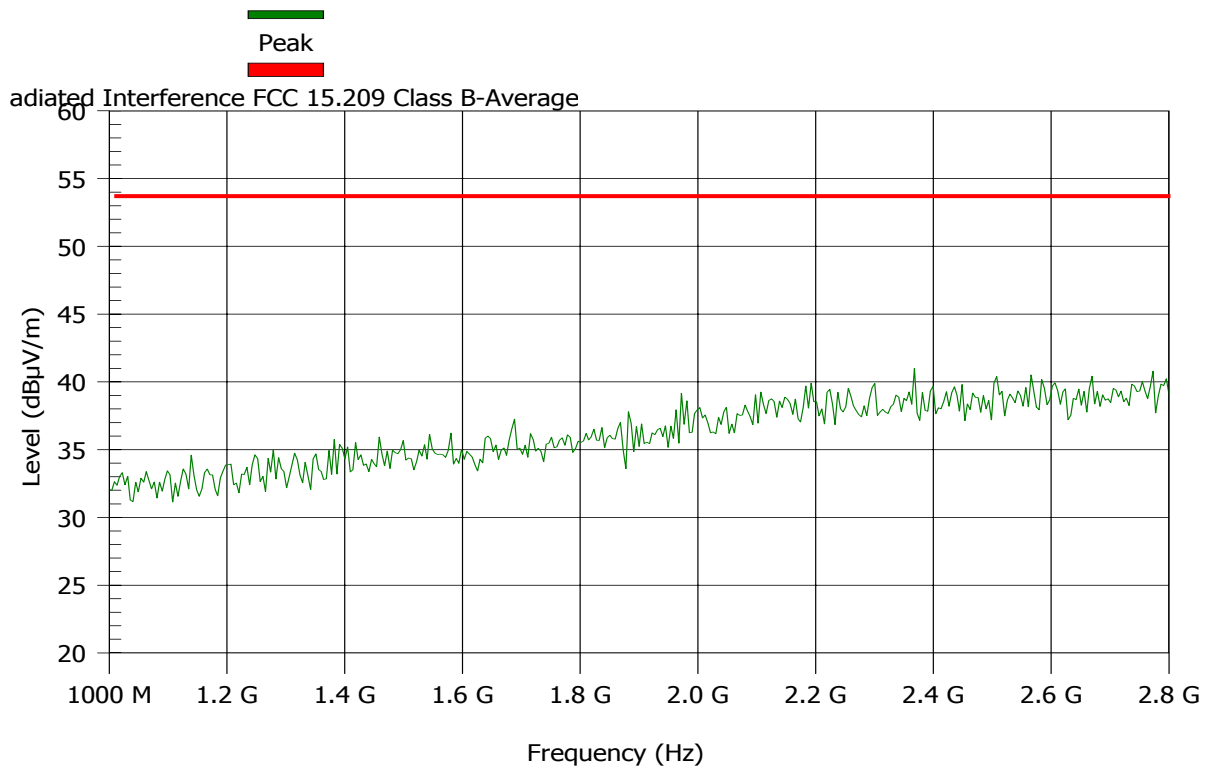

MAXIMUM RESULT DEVIATION:

Detect all peaks above 6 dB below the limit line with a maximum of 6 peaks.

Test Results Plot No 24  
**FCC 15.109 2.8-6GHz**

Test & EUT General Information		Receiver Setting	
EUT Name:	FP-200 SAG	Spect Analyzer	S.A HP 8593E
S/N:	002	Ref. Level:	90 dBμV
Date of Test:		RBW:	100 kHz
Test Engineer:		VBW:	1000 kHz
Antenna:	EMCO 3105 1-18GHz	Sweep Time:	Auto: 960 ms
Polarization:	Horizontal and Vertical	Pre Amplifier	LNA 44db 2-6 GHz

TEST REMARKS:

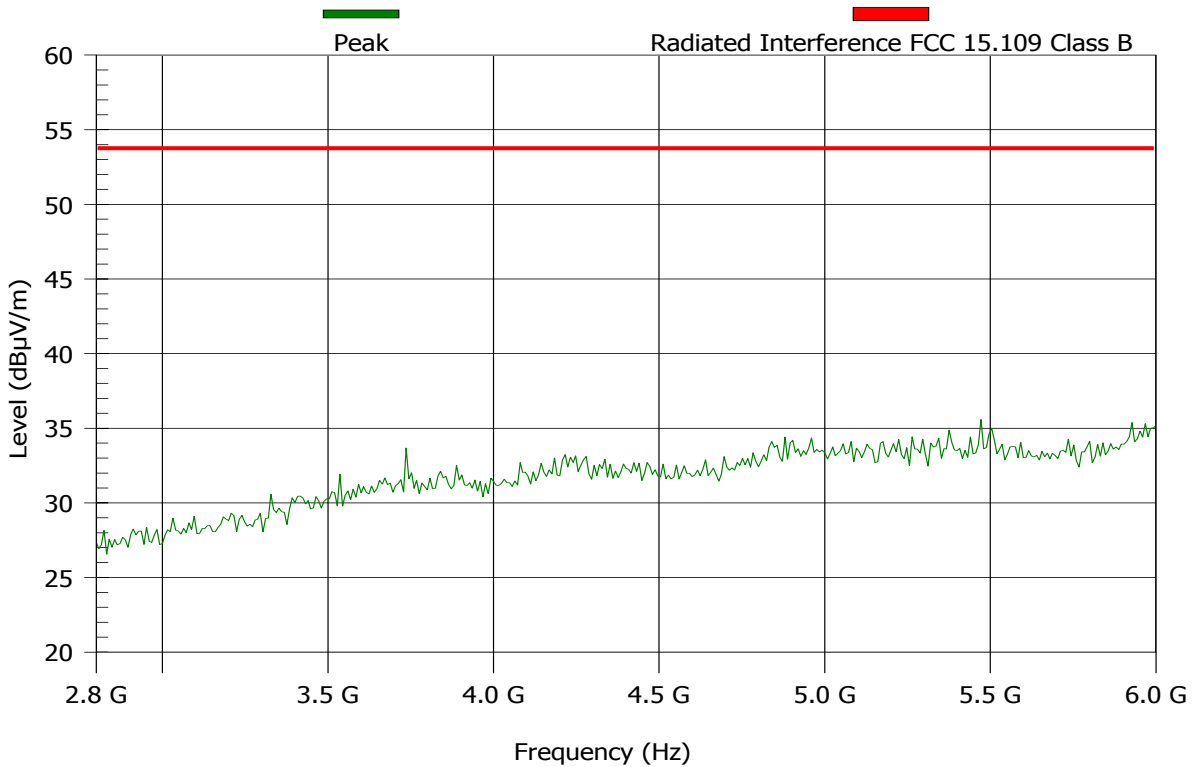

MAXIMUM RESULT DEVIATION:

Detect all peaks above 6 dB below the limit line with a maximum of 6 peaks.

Test Results Plot No 25  
**FCC 15.90 ERP 915MHz VERTICAL**

Test & EUT General Information		Receiver Setting	
EUT Name:	FP-200 SAG-915MHz	Spect Analyzer	S.A HP 8593E
S/N:	2	Ref. Level:	132 dB $\mu$ V
Date of Test:		RBW:	$\Delta$ 3000 kHz
Test Engineer:		VBW:	$\Delta$ 3000 kHz
Antenna:	Frankonia BTA-L_A 3m	Sweep Time:	Auto: 20 ms
Polarization:	Vertical	Pre Amplifier	

TEST REMARKS: 28-08-09  
S/N=2  
TX Carrier field strength.

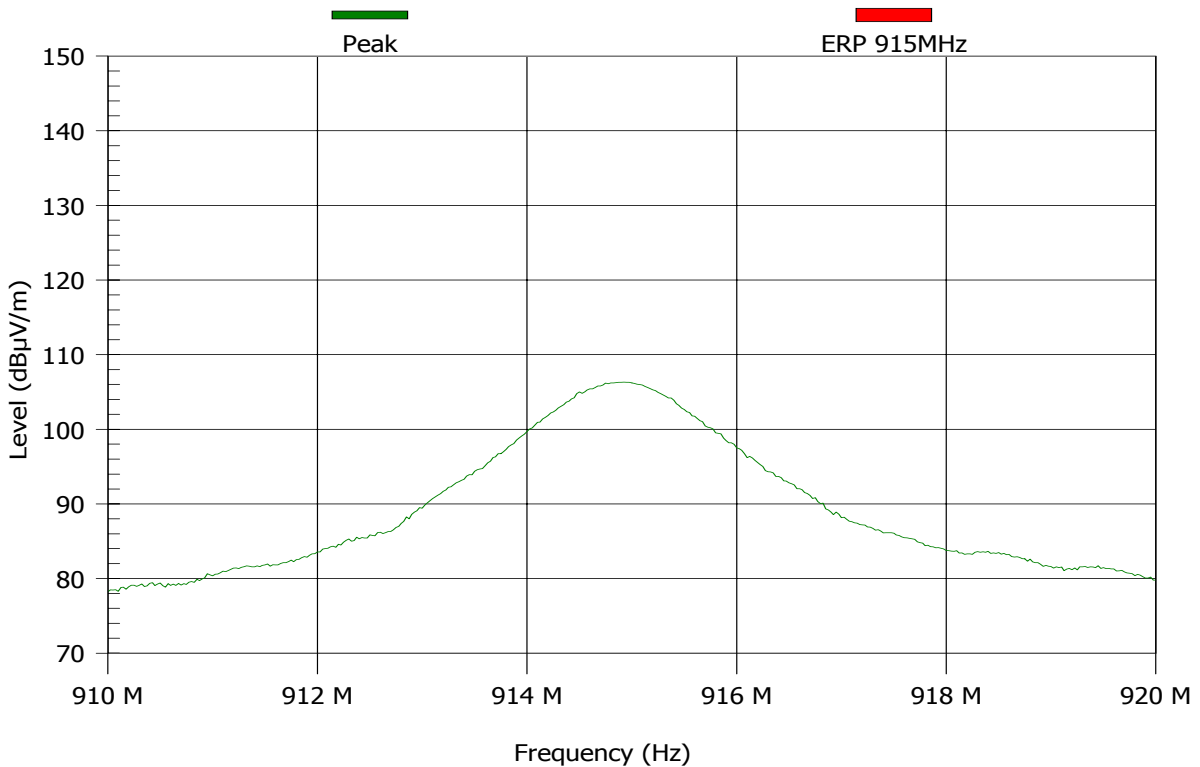

**MAXIMUM RESULT DEVIATION:**

Detect all peaks above 6 dB below the limit line with a maximum of 6 peaks.

Frequency (MHz)	PK MaxHold (dB $\mu$ V/m)	PK Limit (dB $\mu$ V/m)	Result	Angle (degrees)	Height (m)	H/V
914.883	106.5	142	Pass	240	1.6	V

Test Results Plot No 26

**FCC 15.90 ERP 915MHz HORIZONTAL**

Test & EUT General Information		Receiver Setting	
EUT Name:	FP-200 SAG-915MHz	Spect Analyzer	S.A HP 8593E
S/N:	2	Ref. Level:	132 dBµV
Date of Test:		RBW:	Δ 3000 kHz
Test Engineer:		VBW:	Δ 3000 kHz
Antenna:	Frankonia BTA-L_A 3m	Sweep Time:	Auto: 20 ms
Polarization:	Horizontal	Pre Amplifier	

TEST REMARKS:28-08-09

S.G. Carrier=10.7dbm.

Table(angle)=0 degrees.

Antenna(height)=138cm.

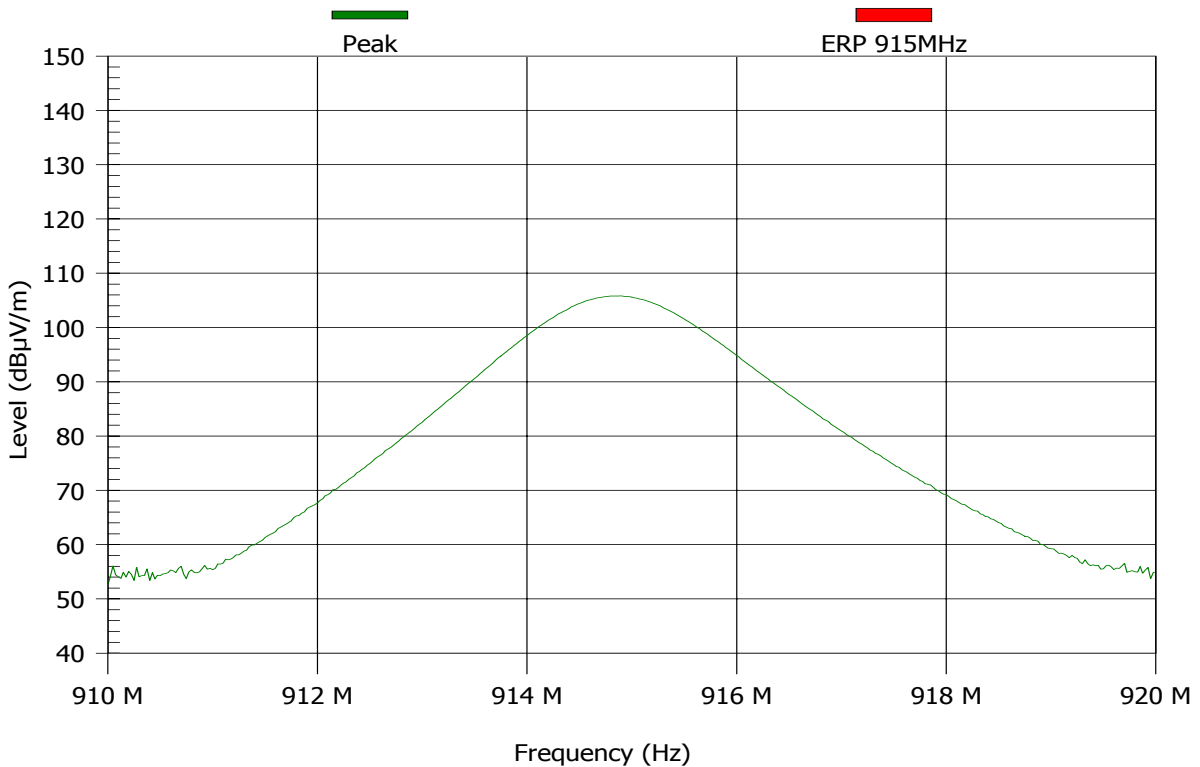

**MAXIMUM RESULT DEVIATION:**

Detect all peaks above 6 dB below the limit line with a maximum of 6 peaks.

N	Frequency (MHz)	PK MaxHold (dBµV/m)	PK Limit (dBµV/m)	Result	Angle (degrees)	Height (m)	H / V
1	914.85	105.8	142	Pass	0	1	H

Test Results Plot No 27  
**FCC 2.1049 Occupied Bandwidth**

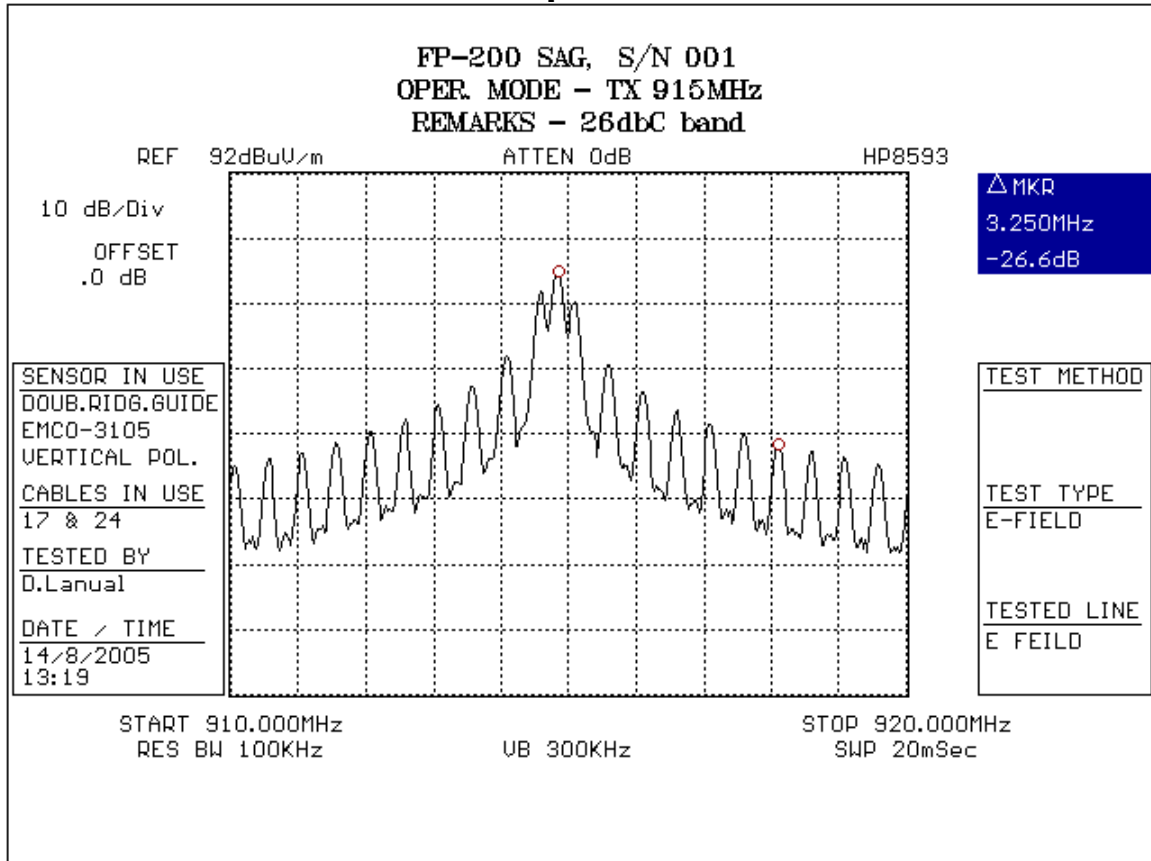

Test Results Plot No 28  
**FCC 2.1049 Occupied Bandwidth**

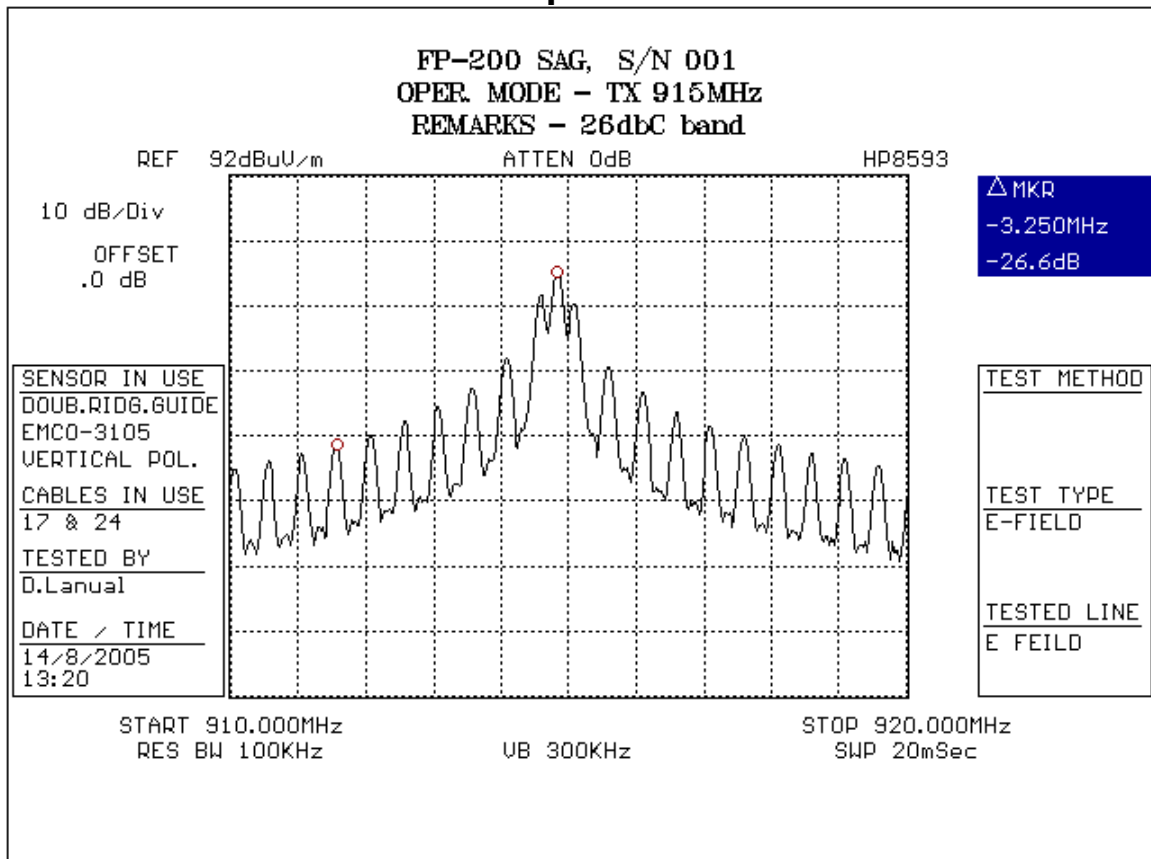

Test Results Plot No 29  
**FCC 90.210 Masks K at 915MHz**

Test & EUT General Information		Receiver Setting	
EUT Name:	FP-200 SAG-915MHz	Spect Analyzer	S.A HP 8593E
S/N:	2	Ref. Level:	115 dBµV
Date of Test:		RBW:	100 kHz
Test Engineer:		VBW:	1000 kHz
Antenna:	Frankonia BTA-L_A 3m	Sweep Time:	Auto: 20 ms
Polarization:	Horizontal and Vertical	Pre Amplifier	

TEST REMARKS:01-09-2005  
SN=2

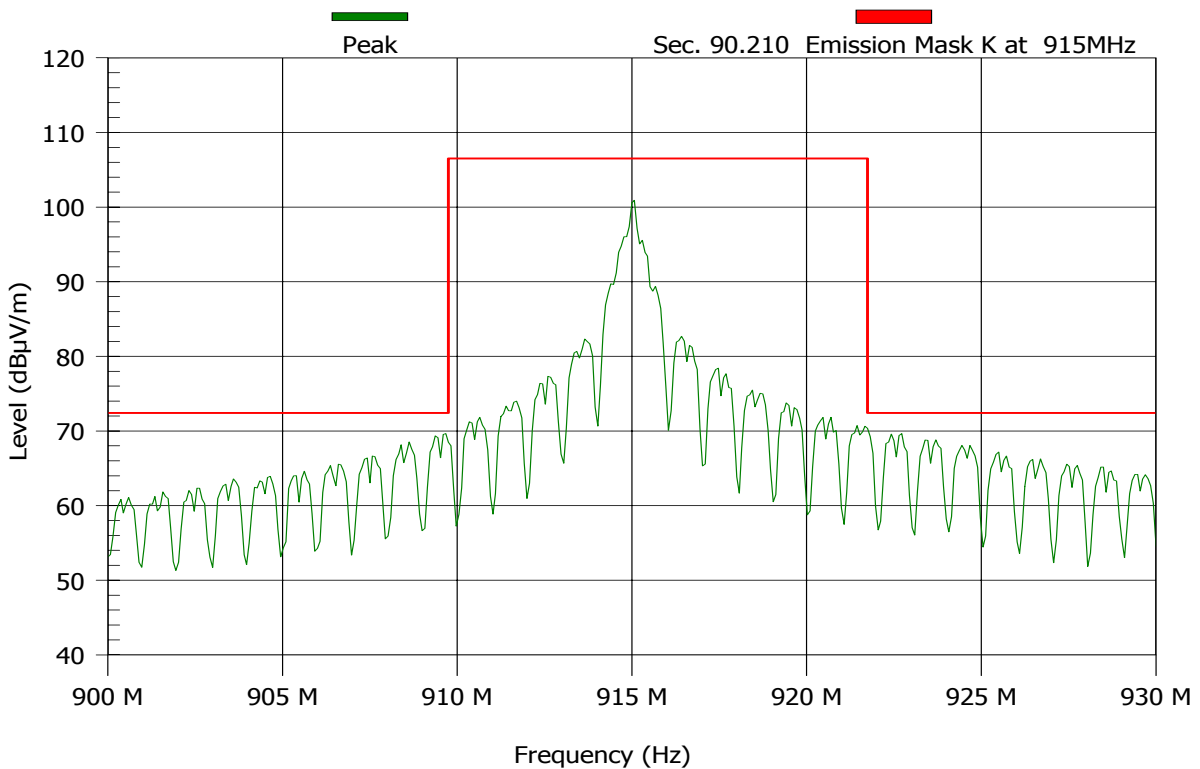

**MAXIMUM RESULT DEVIATION:**

Detect all peaks above 6 dB below the limit line with a maximum of 6 peaks.

Freq (MHz)	PK MaxHold (dBµV/m)	PK Limit (dBµV/m)	Result	Angle (degrees)	Height (m)	H/V
909.312	69.3	72.4	Pass	180	1	H
909.557	69.9	72.4	Pass	180	1	H
922.311	69.9	72.4	Pass	240	1.3	V
922.548	69.6	72.4	Pass	240	1.3	V
923.561	68.9	72.4	Pass	240	1.3	V



Test Results Plot No 30  
**FCC 90.210 Mask K at 915MHz 2nd Test**

Test & EUT General Information		Receiver Setting	
EUT Name:	FP-200 SAG-915MHz	Spect Analyzer	S.A HP 8593E
S/N:	2	Ref. Level:	115 dBμV
Date of Test:		RBW:	1000 kHz
Test Engineer:		VBW:	1000 kHz
Antenna:	Frankonia BTA-L_A 3m	Sweep Time:	Auto: 20 ms
Polarization:	Horizontal and Vertical	Pre Amplifier	

TEST REMARKS:01-09-2005  
SN=2

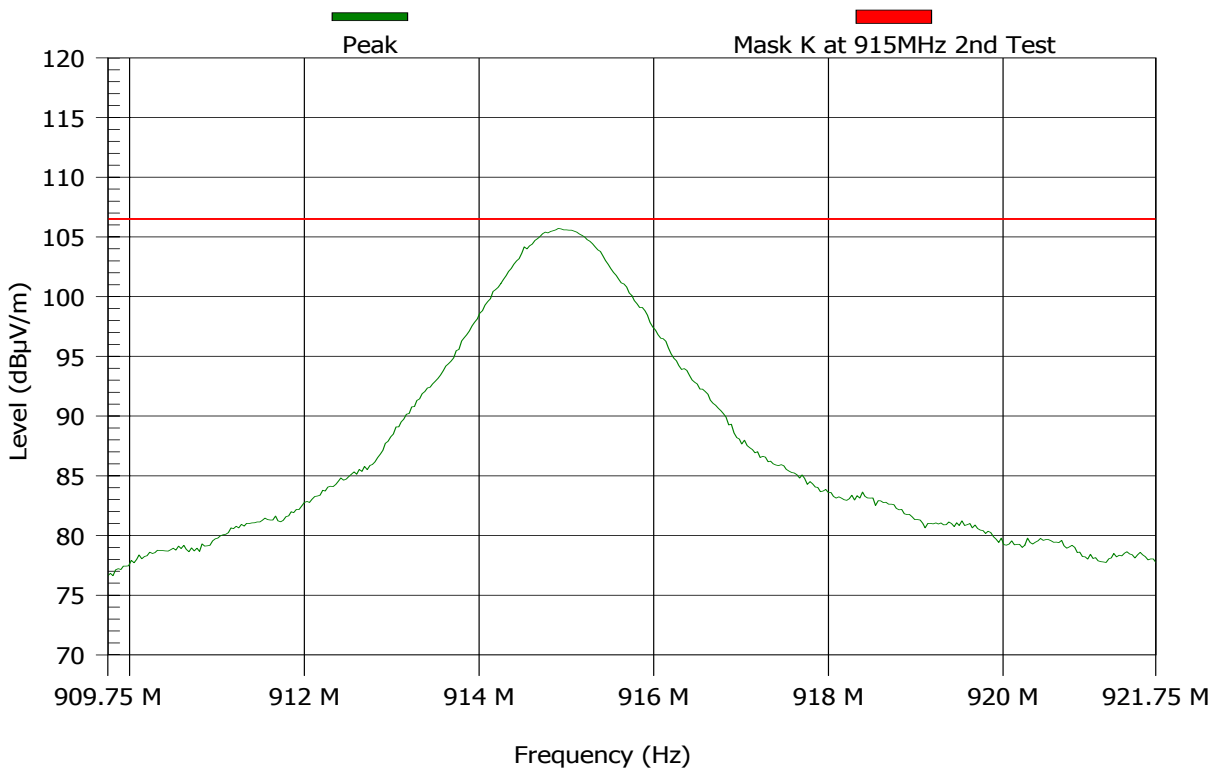

**MAXIMUM RESULT DEVIATION:**

Detect all peaks above 6 dB below the limit line with a maximum of 6 peaks.

Freq (MHz)	PK MaxHold (dBμV/m)	PK Limit (dBμV/m)	Result	Angle (degrees)	Height (m)	H/V
914.907	105.8	106.5	Pass	240	1.3	V

Test Results Plot No 31  
**FCC 90.210 Radiated Spurious 0.009-0.15MHz VER**

Test & EUT General Information		Receiver Setting	
EUT Name:	FP-200 SAG-915MHz	Spect Analyzer	S.A HP 8593E
S/N:	2	Ref. Level:	90 dB $\mu$ V
Date of Test:		RBW:	1000 Hz
Test Engineer:		VBW:	3 kHz
Antenna:	LOOP ANT.HFH 2 Z2	Sweep Time:	Auto: 423 ms
Polarization:	Vertical	Pre Amplifier	

TEST REMARKS:01-09-2005  
SN=2

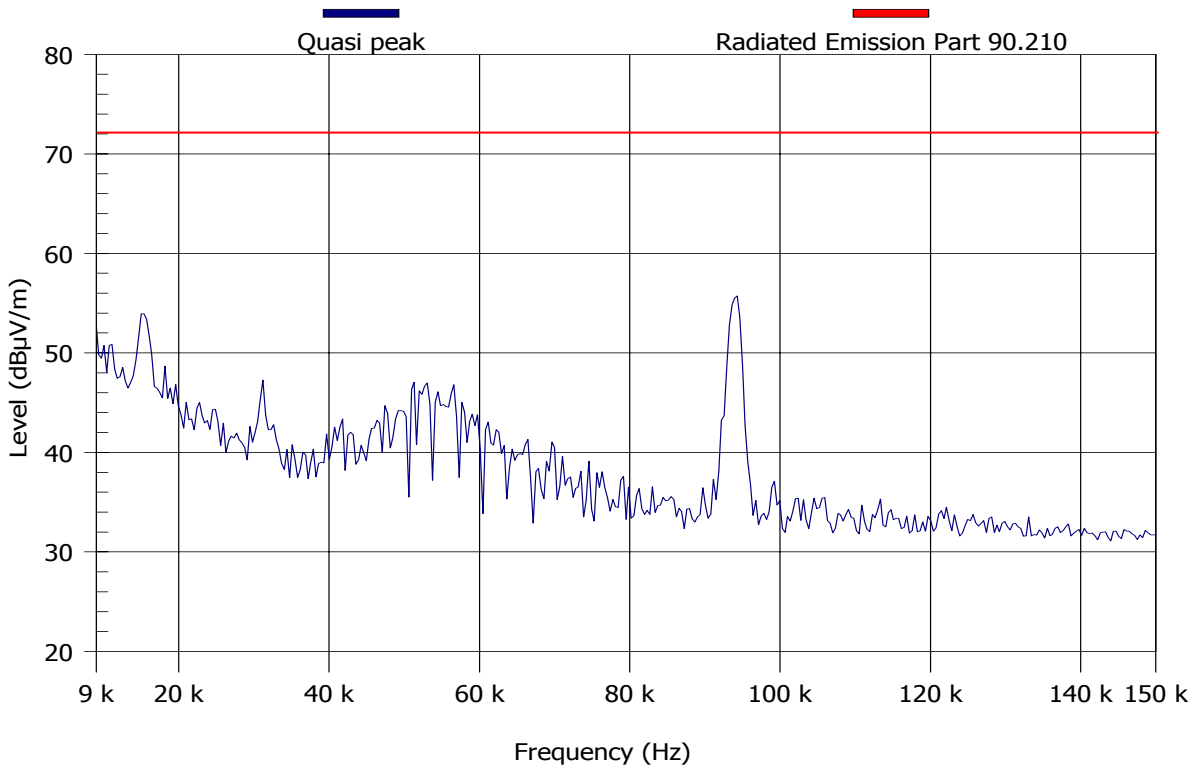

Test Results Plot No 32  
**FCC 90.210 Radiated Spurious 0.009-0.15MHz HOR**

Test & EUT General Information		Receiver Setting	
EUT Name:	FP-200 SAG-915MHz	Spect Analyzer	S.A HP 8593E
S/N:	2	Ref. Level:	90 dB $\mu$ V
Date of Test:		RBW:	1000 Hz
Test Engineer:		VBW:	3 kHz
Antenna:	LOOP ANT.HFH 2 Z2	Sweep Time:	Auto: 423 ms
Polarization:	Horizontal	Pre Amplifier	

TEST REMARKS:01-09-2005  
SN=2

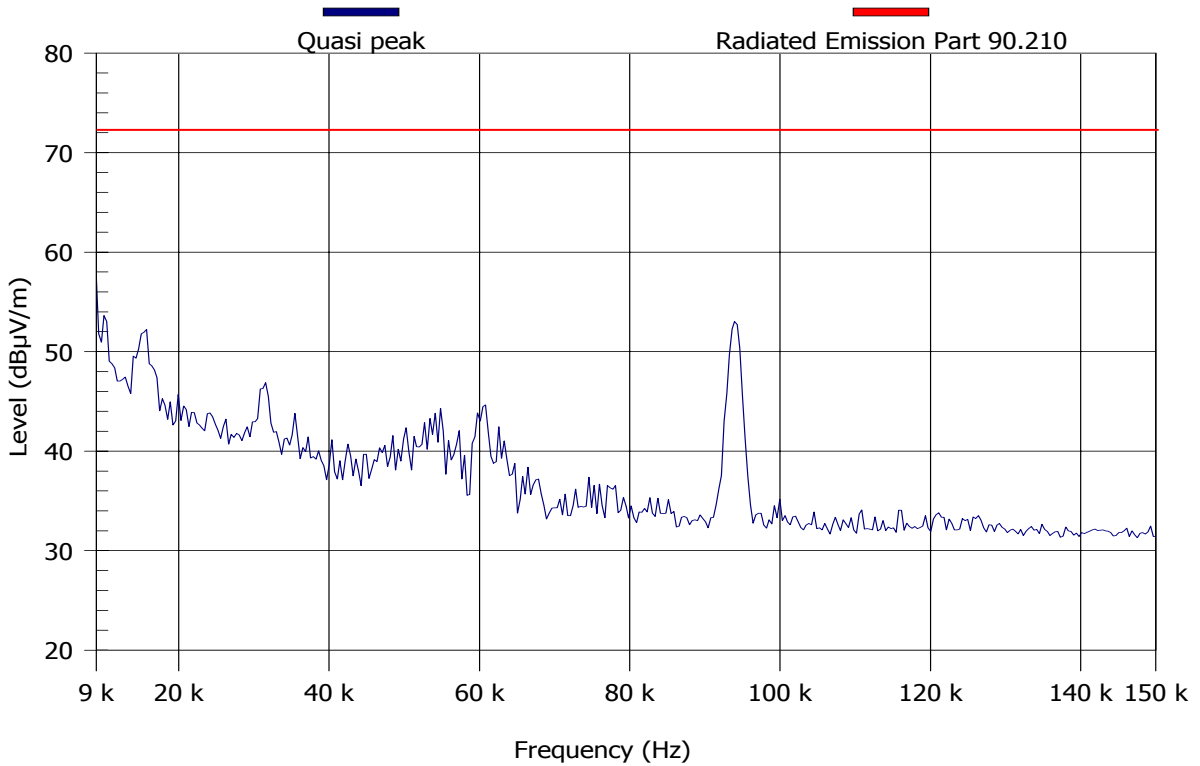

Test Results Plot No 33  
**FCC 90.210 Radiated Spurious 0.15-30MHz VER**

Test & EUT General Information		Receiver Setting	
EUT Name:	FP-200 SAG-915MHz	Spect Analyzer	S.A HP 8593E
S/N:	2	Ref. Level:	90 dB $\mu$ V
Date of Test:		RBW:	10 kHz
Test Engineer:		VBW:	30 kHz
Antenna:	LOOP ANT.HFH 2 Z2	Sweep Time:	Auto: 895.5 ms
Polarization:	Vertical	Pre Amplifier	

TEST REMARKS:01-09-2005  
SN=2

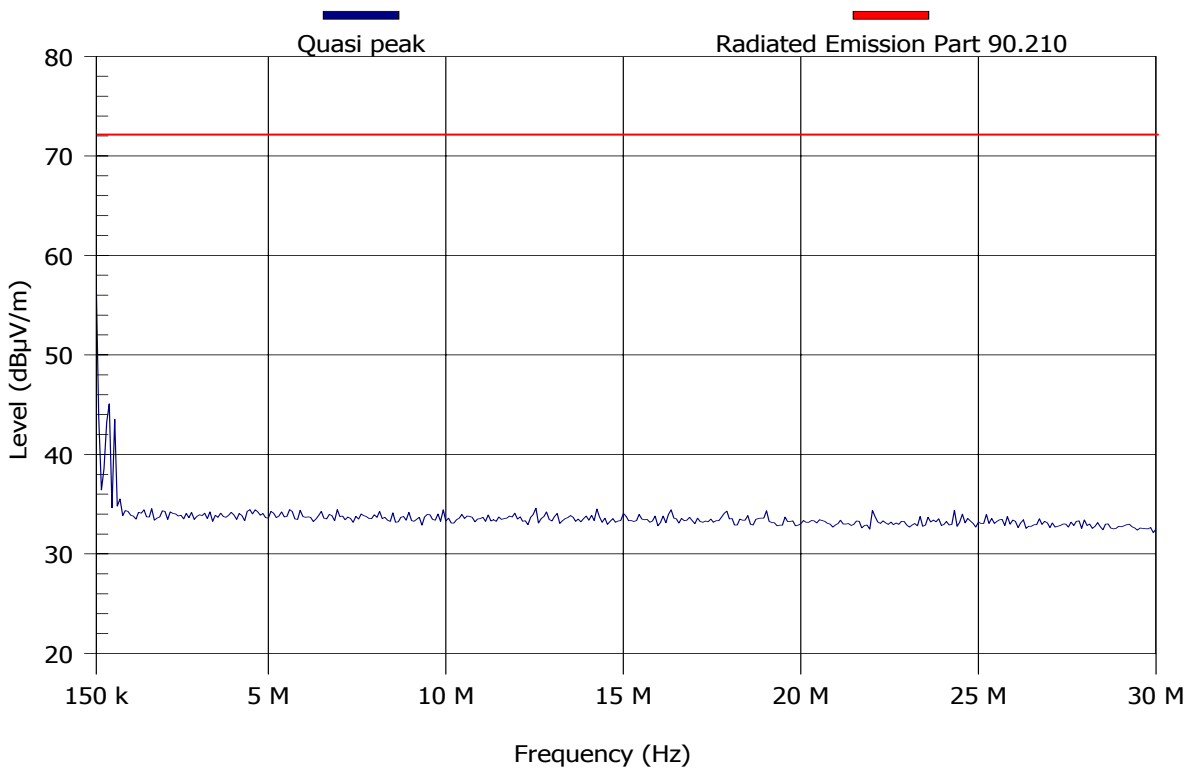

Test Results Plot No 34  
**FCC 90.210 Radiated Spurious 0.15-30MHz HOR**

Test & EUT General Information		Receiver Setting	
EUT Name:	FP-200 SAG-915MHz	Spect Analyzer	S.A HP 8593E
S/N:	2	Ref. Level:	90 dB $\mu$ V
Date of Test:		RBW:	10 kHz
Test Engineer:		VBW:	30 kHz
Antenna:	LOOP ANT.HFH 2 Z2	Sweep Time:	Auto: 895.5 ms
Polarization:	Horizontal	Pre Amplifier	

TEST REMARKS:01-09-2005  
SN=2

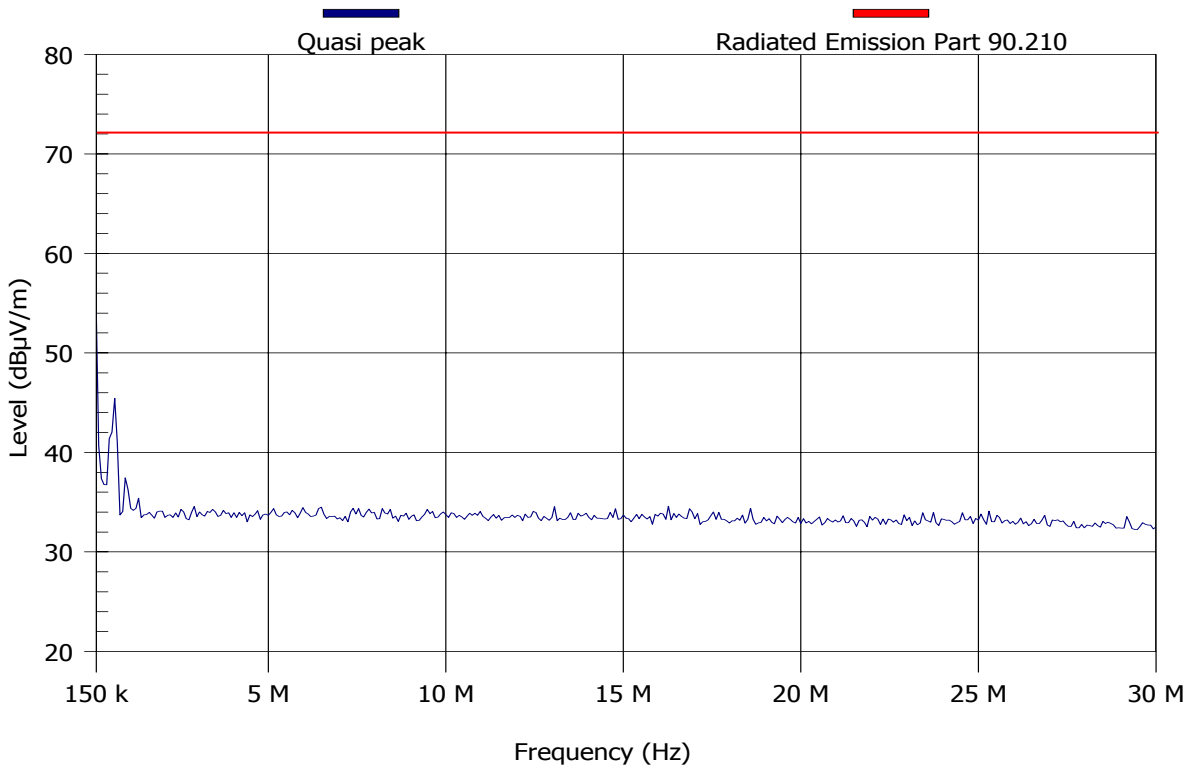

Test Results Plot No 35  
**FCC 90.210 30-1000MHz**

Test & EUT General Information		Receiver Setting	
EUT Name:	FP-200 SAG-915MHz	Spect Analyzer	S.A HP 8593E
S/N:	2	Ref. Level:	90 dBµV
Date of Test:		RBW:	100 kHz
Test Engineer:		VBW:	1000 kHz
Antenna:	Frankonia BTA-L_A 3m	Sweep Time:	Auto: 291 ms
Polarization:	Horizontal and Vertical	Pre Amplifier	

TEST REMARKS:28-08-09  
S/N=2  
Radiated Spurious Emission.

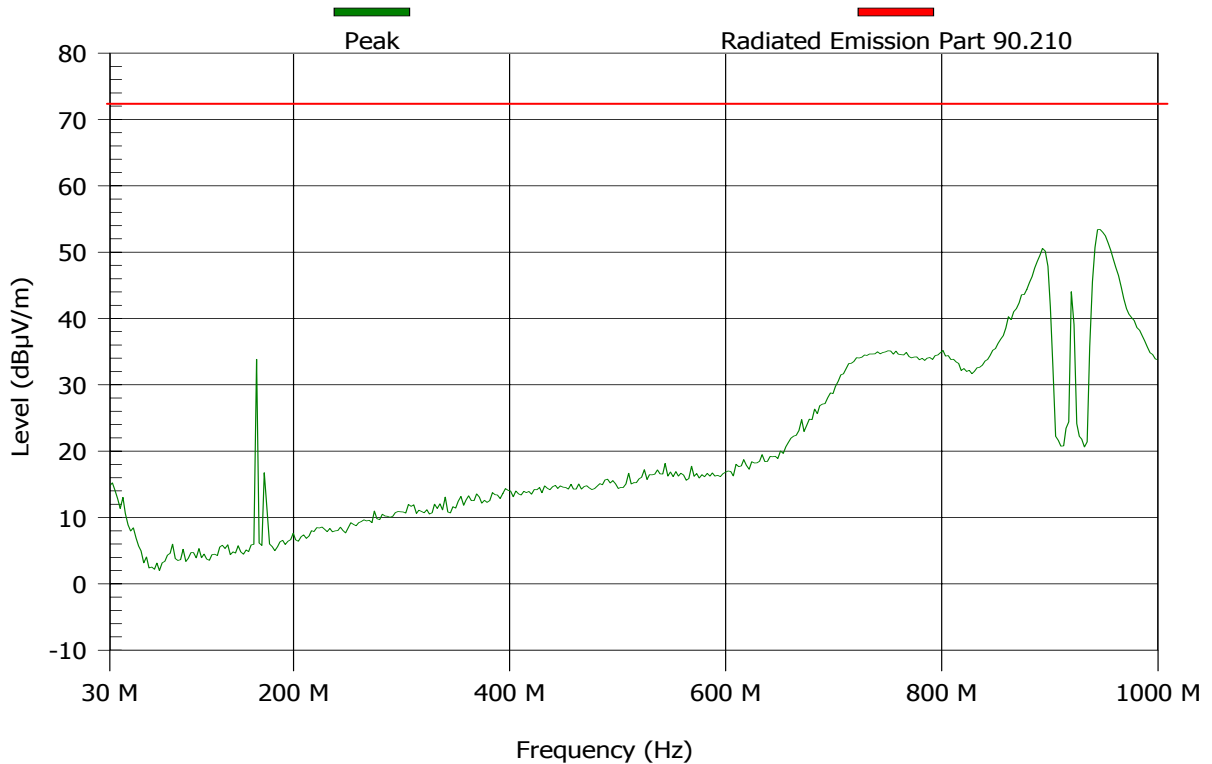

**MAXIMUM RESULT DEVIATION:**

Detect all peaks above 6 dB below the limit line with a maximum of 6 peaks.  
None

Test Results Plot No 36  
**FCC 90.210 100-200MHz**

Test & EUT General Information		Receiver Setting	
EUT Name:	FP-200 SAG-915MHz	Spect Analyzer	S.A HP 8593E
S/N:	2	Ref. Level:	90 dB $\mu$ V
Date of Test:		RBW:	100 kHz
Test Engineer:		VBW:	1000 kHz
Antenna:	Frankonia BTA-L_A 3m	Sweep Time:	Auto: 30 ms
Polarization:	Horizontal and Vertical	Pre Amplifier	

TEST REMARKS:28-08-09  
S/N=2  
Radiated Spurious Emission.

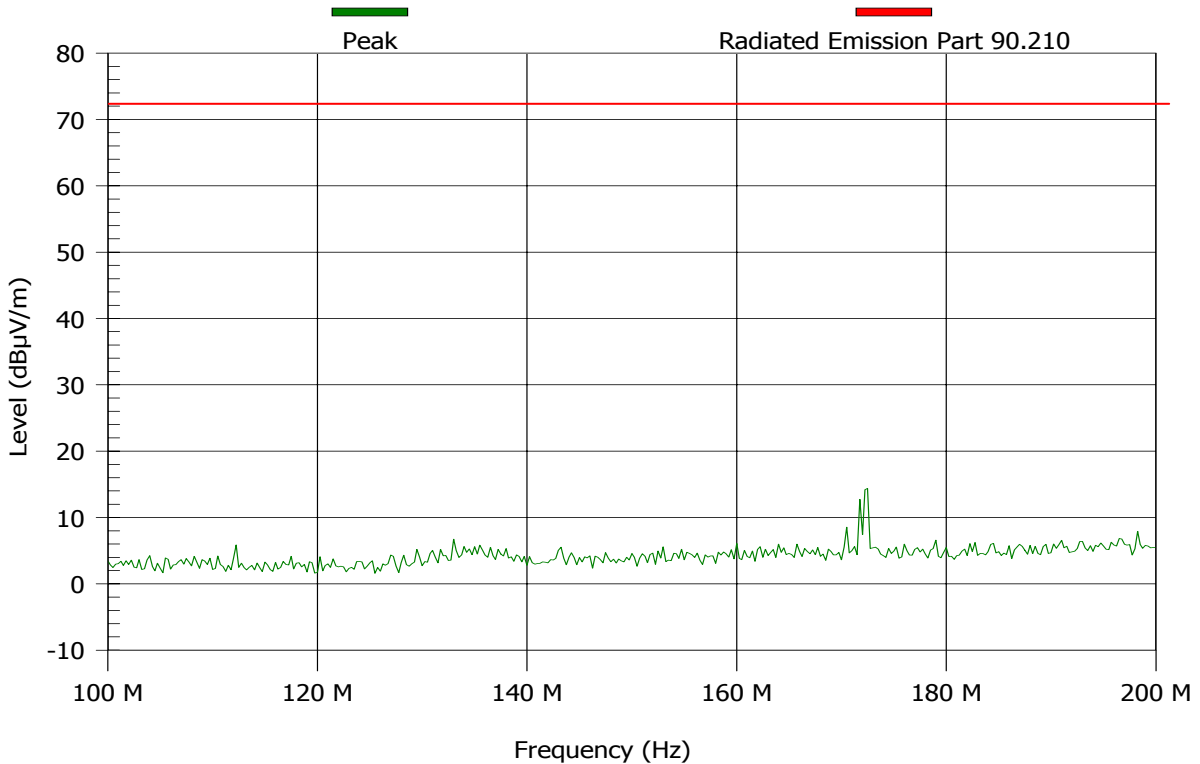

**MAXIMUM RESULT DEVIATION:**

Detect all peaks above 6 dB below the limit line with a maximum of 6 peaks.  
None

Test Results Plot No 37  
**FCC 90.210 100-400MHz**

Test & EUT General Information		Receiver Setting	
EUT Name:	FP-200 SAG-915MHz	Spect Analyzer	S.A HP 8593E
S/N:	2	Ref. Level:	90 dBµV
Date of Test:		RBW:	100 kHz
Test Engineer:		VBW:	1000 kHz
Antenna:	Frankonia BTA-L_A 3m	Sweep Time:	Auto: 90 ms
Polarization:	Horizontal and Vertical	Pre Amplifier	

TEST REMARKS:28-08-09  
S/N=2  
Radiated Spurious Emission.

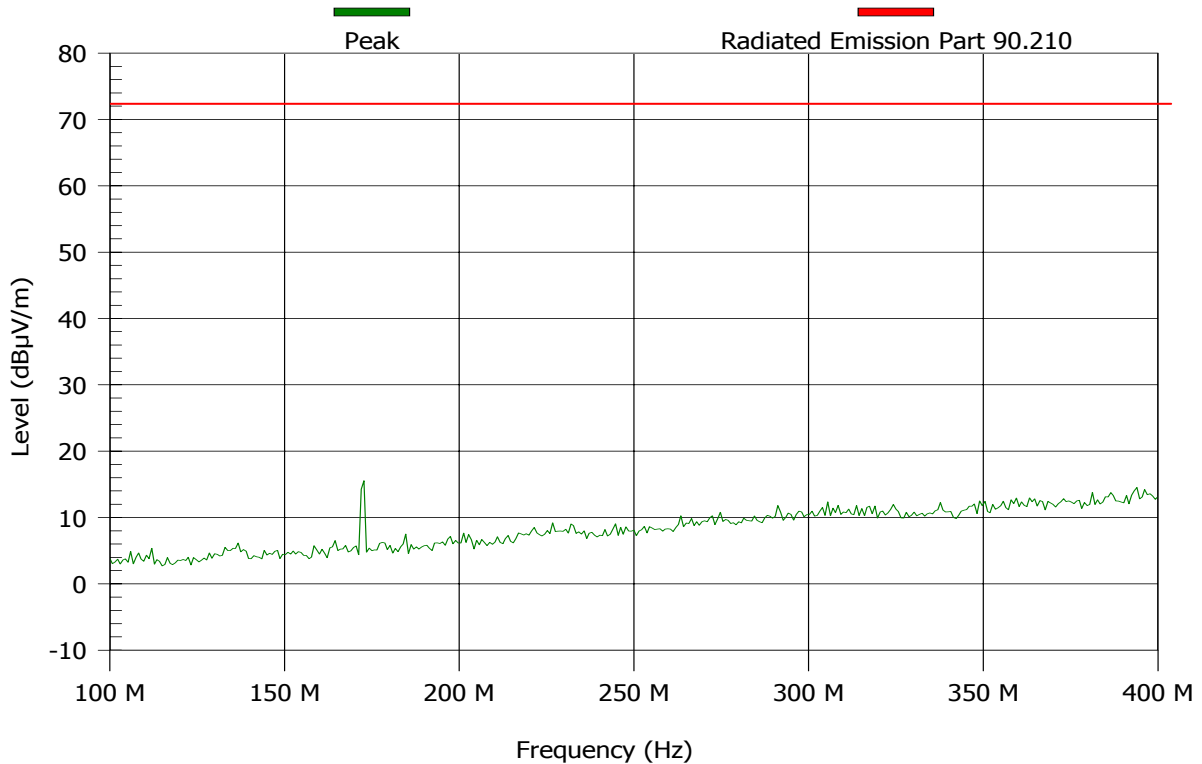

**MAXIMUM RESULT DEVIATION:**

Detect all peaks above 6 dB below the limit line with a maximum of 6 peaks.  
None



Test Results Plot No 38  
**FCC 90.210 1-2.8GHz**

Test & EUT General Information		Receiver Setting	
EUT Name:	FP-200 SAG-915MHz	Spect Analyzer	S.A HP 8593E
S/N:	2	Ref. Level:	90 dBµV
Date of Test:		RBW:	100 kHz
Test Engineer:		VBW:	1000 kHz
Antenna:	EMCO 3105 1-18GHz	Sweep Time:	Auto: 540 ms
Polarization:	Horizontal and Vertical	Pre Amplifier	pre amp 1GHz-4GHz

TEST REMARKS:28-08-09  
S/N=2  
Radiated Spurious Emission.  
With Band Reject Filter(915MHz).

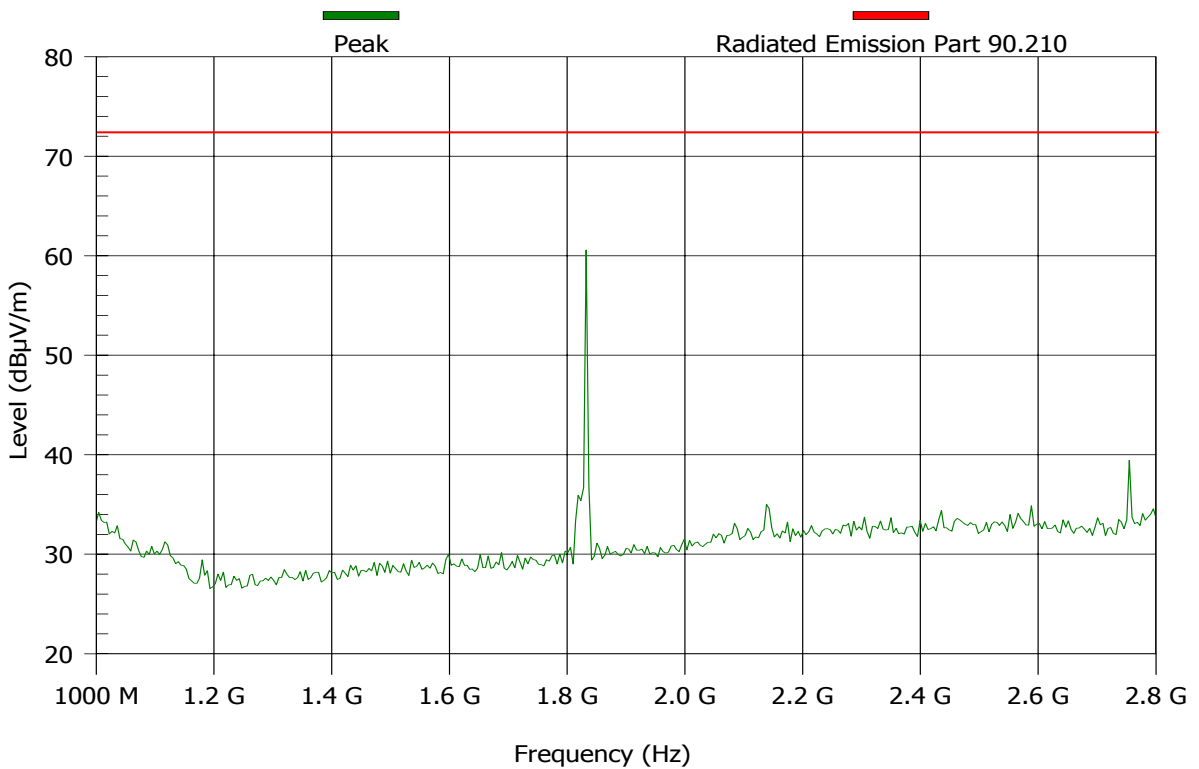

**MAXIMUM RESULT DEVIATION:**

Detect all peaks above 6 dB below the limit line with a maximum of 6 peaks.

Freq (MHz)	PK MaxHold (dBµV/m)	PK Limit (dBµV/m)	Result	Angle (degrees)	Height (m)	H/V
1829.889	60.8	72.4	Pass	240	1	V

Test Results Plot No 39  
**FCC 90.210 2.8-6GHz**

Test & EUT General Information		Receiver Setting	
EUT Name:	FP-200 SAG-915MHz	Spect Analyzer	S.A HP 8593E
S/N:	2	Ref. Level:	90 dB $\mu$ V
Date of Test:		RBW:	100 kHz
Test Engineer:		VBW:	1000 kHz
Antenna:	EMCO 3105 1-18GHz	Sweep Time:	Auto: 960 ms
Polarization:	Horizontal and Vertical	Pre Amplifier	ELISRA AMP 2-6 GHz

TEST REMARKS:28-08-09  
S/N=2  
Radiated Spurious Emission.

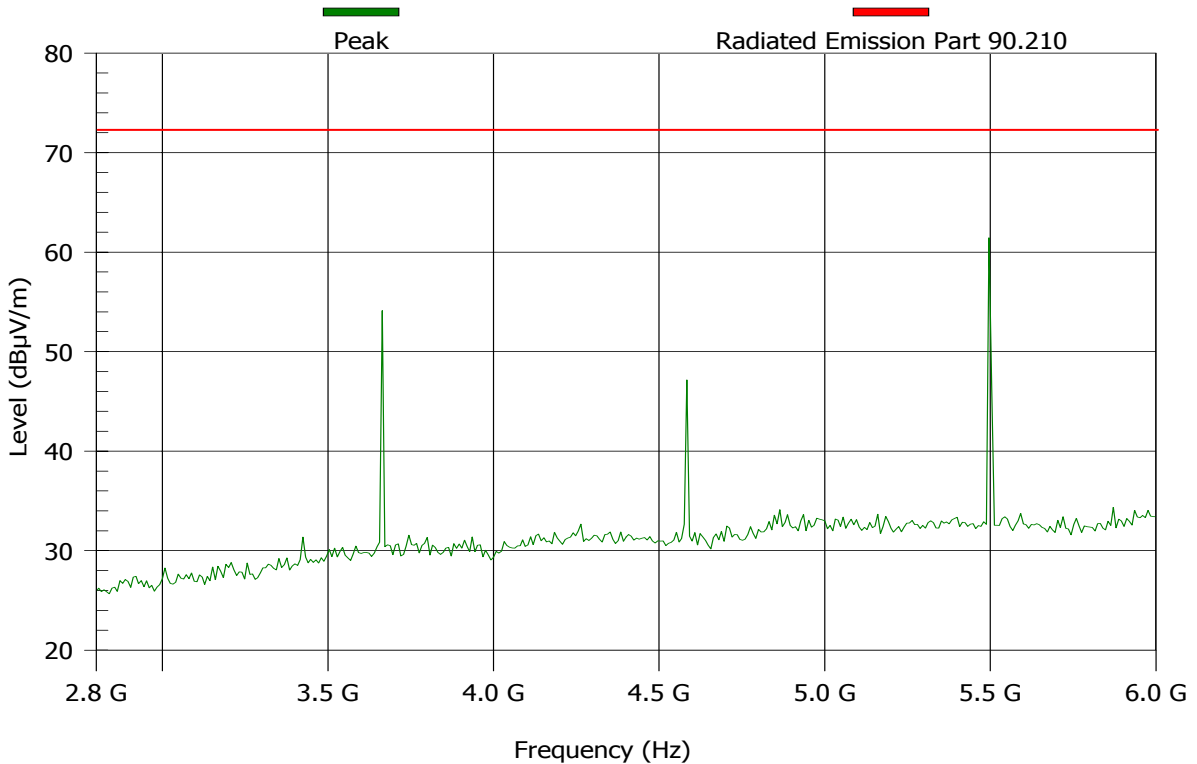

**MAXIMUM RESULT DEVIATION:**

Detect all peaks above 6 dB below the limit line with a maximum of 6 peaks.

Frequency (MHz)	PK MaxHold (dB $\mu$ V/m)	PK Limit (dB $\mu$ V/m)	Result	Angle (degrees)	Height (m)	H/ V
3659.784	54.6	72.4	Pass	180	1.6	V
4574.73	46.8	72.4	Pass	240	1.6	H
5489.683	61.8	72.4	Pass	240	1.3	V

Test Results Plot No 40  
**FCC 90.210 6-8GHz**

Test & EUT General Information		Receiver Setting	
EUT Name:	FP-200 SAG-915MHz	Spect Analyzer	S.A HP 8593E
S/N:	2	Ref. Level:	90 dBµV
Date of Test:		RBW:	100 kHz
Test Engineer:		VBW:	1000 kHz
Antenna:	Virtual Antenna ce106 6-18ghz	Sweep Time:	Auto: 600 ms
Polarization:	Horizontal and Vertical	Pre Amplifier	ELISRA AMP 6-18 GHz

TEST REMARKS:28-08-09  
S/N=2  
Radiated Spurious Emission.

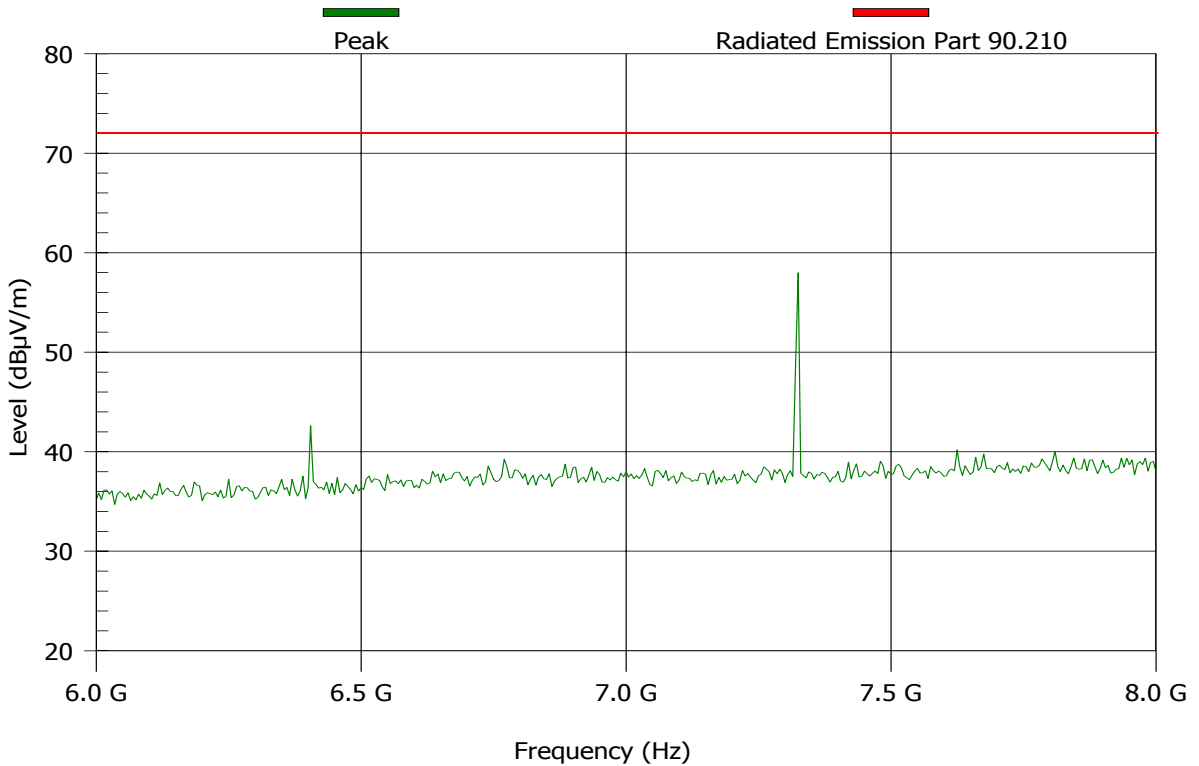

**MAXIMUM RESULT DEVIATION:**

Detect all peaks above 6 dB below the limit line with a maximum of 6 peaks.

Frequency (MHz)	PK MaxHold (dBµV/m)	PK Limit (dBµV/m)	Result	Angle (degrees)	Height (m)	H/V
6404.628	44.6	72.4	Pass	180	1.6	V
7319.583	58.2	72.4	Pass	120	1.3	V

Test Results Plot No 41  
**FCC 90.210 8-10GHz**

Test & EUT General Information		Receiver Setting	
EUT Name:	FP-200 SAG-915MHz	Spect Analyzer	S.A HP 8593E
S/N:	2	Ref. Level:	90 dB $\mu$ V
Date of Test:		RBW:	100 kHz
Test Engineer:		VBW:	1000 kHz
Antenna:	Virtual Antenna ce106 6-18ghz	Sweep Time:	Auto: 600 ms
Polarization:	Horizontal and Vertical	Pre Amplifier	ELISRA AMP 6-18 GHz

TEST REMARKS:28-08-09  
S/N=2  
Radiated Spurious Emission.

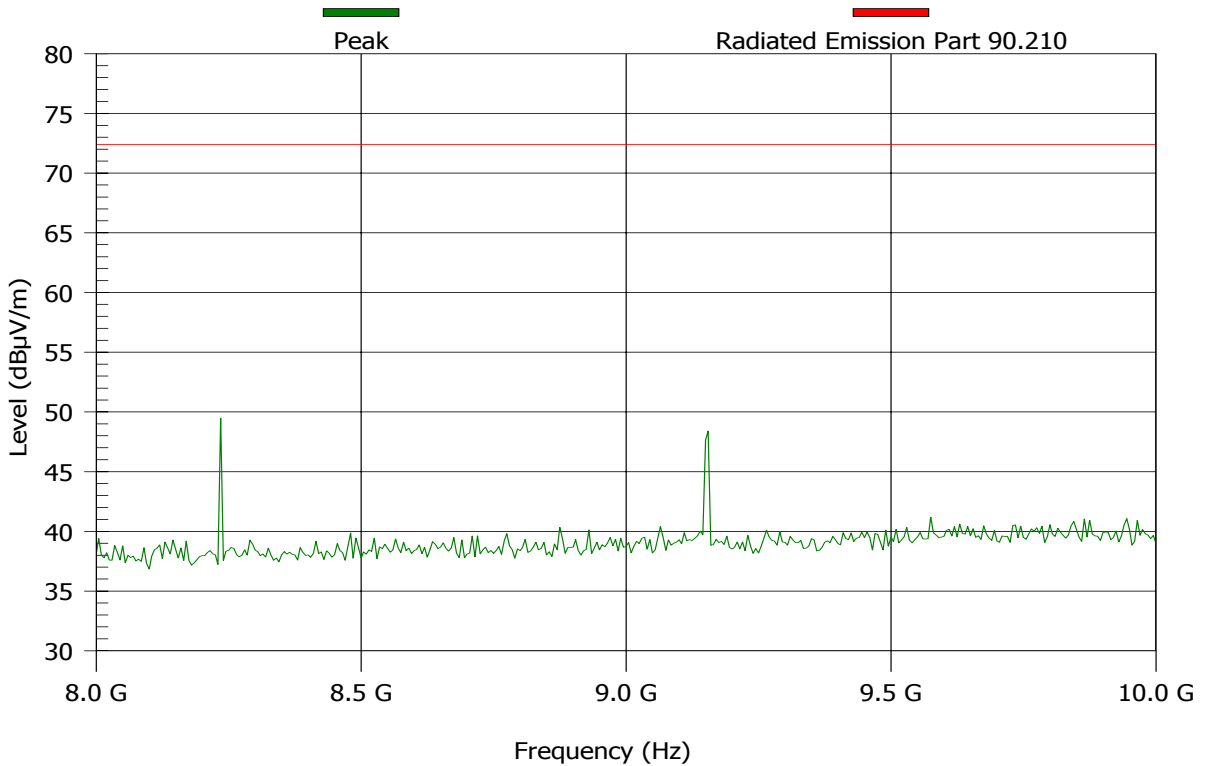

**MAXIMUM RESULT DEVIATION:**

Detect all peaks above 6 dB below the limit line with a maximum of 6 peaks.

Frequency (MHz)	PK MaxHold (dB $\mu$ V/m)	PK Limit (dB $\mu$ V/m)	Result	Angle (degrees)	Height (m)	H/V
8234.529	51	72.4	Pass	120	1.3	V
9149.473	49.2	72.4	Pass	180	1.6	H

Test Results Plot No 42

**FCC 90.210 1.8-1.9GHz 2nd Harmonic VER**

Test & EUT General Information		Receiver Setting	
EUT Name:	FP-200 SAG-915MHz	Spect Analyzer	S.A HP 8593E
S/N:	2	Ref. Level:	90 dBμV
Date of Test:		RBW:	1000 kHz
Test Engineer:		VBW:	1000 kHz
Antenna:	EMCO 3105 1-18GHz	Sweep Time:	Auto: 30 ms
Polarization:	Vertical	Pre Amplifier	pre amp 1GHz-4GHz

TEST REMARKS:29-08-05

2nd Harmonic Test VER.

S/N=2

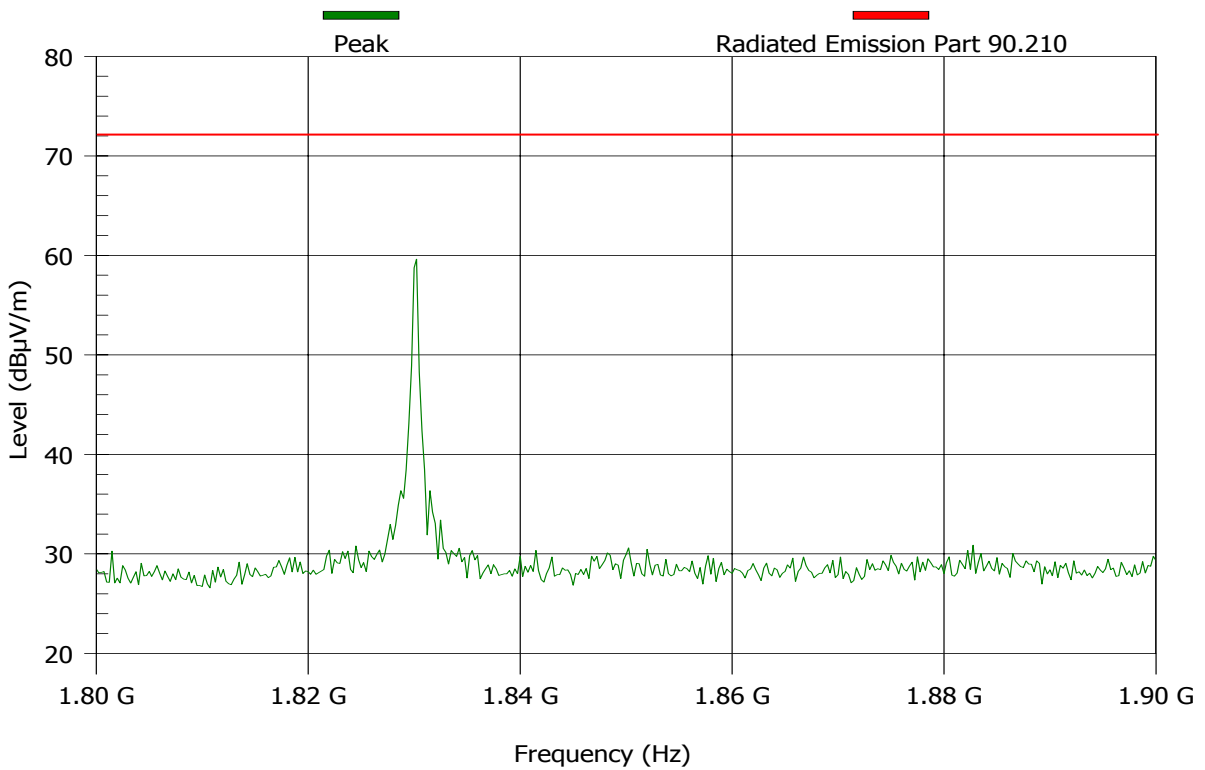

**MAXIMUM RESULT DEVIATION:**

Detect all peaks above 6 dB below the limit line with a maximum of 6 peaks.

Frequency (MHz)	PK MaxHold (dBμV/m)	PK Limit (dBμV/m)	Result	Angle (degrees)	Height (m)	H/V
1829.895	60	72.4	Pass	240	1	V

Test Results Plot No 43

**FCC 90.210 1.8-1.9GHz 2nd Harmonic HOR**

Test & EUT General Information		Receiver Setting	
EUT Name:	FP-200 SAG-915MHz	Spect Analyzer	S.A HP 8593E
S/N:	2	Ref. Level:	90 dB $\mu$ V
Date of Test:		RBW:	100 kHz
Test Engineer:		VBW:	1000 kHz
Antenna:	EMCO 3105 1-18GHz	Sweep Time:	Auto: 30 ms
Polarization:	Horizontal	Pre Amplifier	pre amp 1GHz-4GHz

TEST REMARKS:29-08-05  
2nd Harmonic Test HOR.  
S/N=2

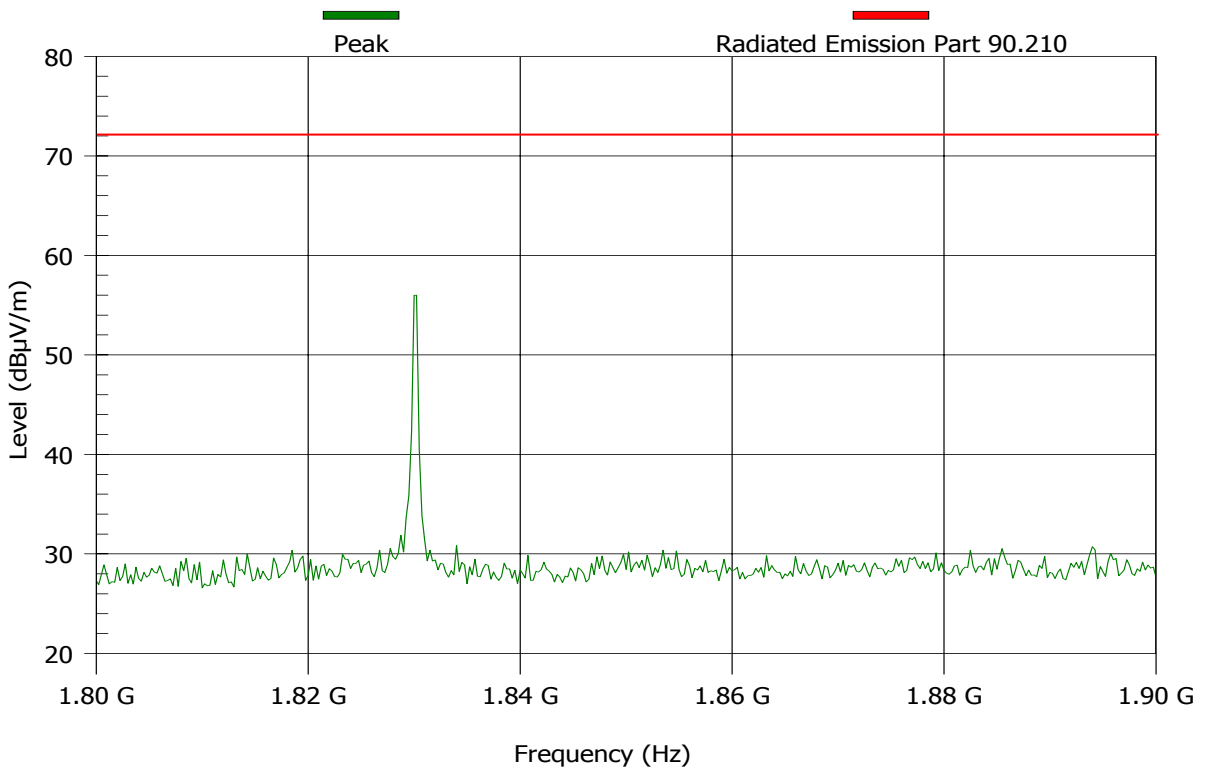

MAXIMUM RESULT DEVIATION:

Detect all peaks above 6 dB below the limit line with a maximum of 6 peaks.

Frequency (MHz)	PK MaxHold (dB $\mu$ V/m)	PK Limit (dB $\mu$ V/m)	Result	Angle (degrees)	Height (m)	H/V
1829.899	56.1	72.4	Pass	60	1.6	H

Test Results Plot No 44  
**FCC 90.210 3.6-3.7GHz 3rd Harmonic VER**

Test & EUT General Information		Receiver Setting	
EUT Name:	FP-200 SAG-915MHz	Spect Analyzer	S.A HP 8593E
S/N:	2	Ref. Level:	90 dBµV
Date of Test:		RBW:	100 kHz
Test Engineer:		VBW:	1000 kHz
Antenna:	EMCO 3105 1-18GHz	Sweep Time:	Auto: 30 ms
Polarization:	Vertical	Pre Amplifier	ELISRA AMP 2-6 GHz

TEST REMARKS:29-08-05  
3rd Harmonic Test VER.  
S/N=2

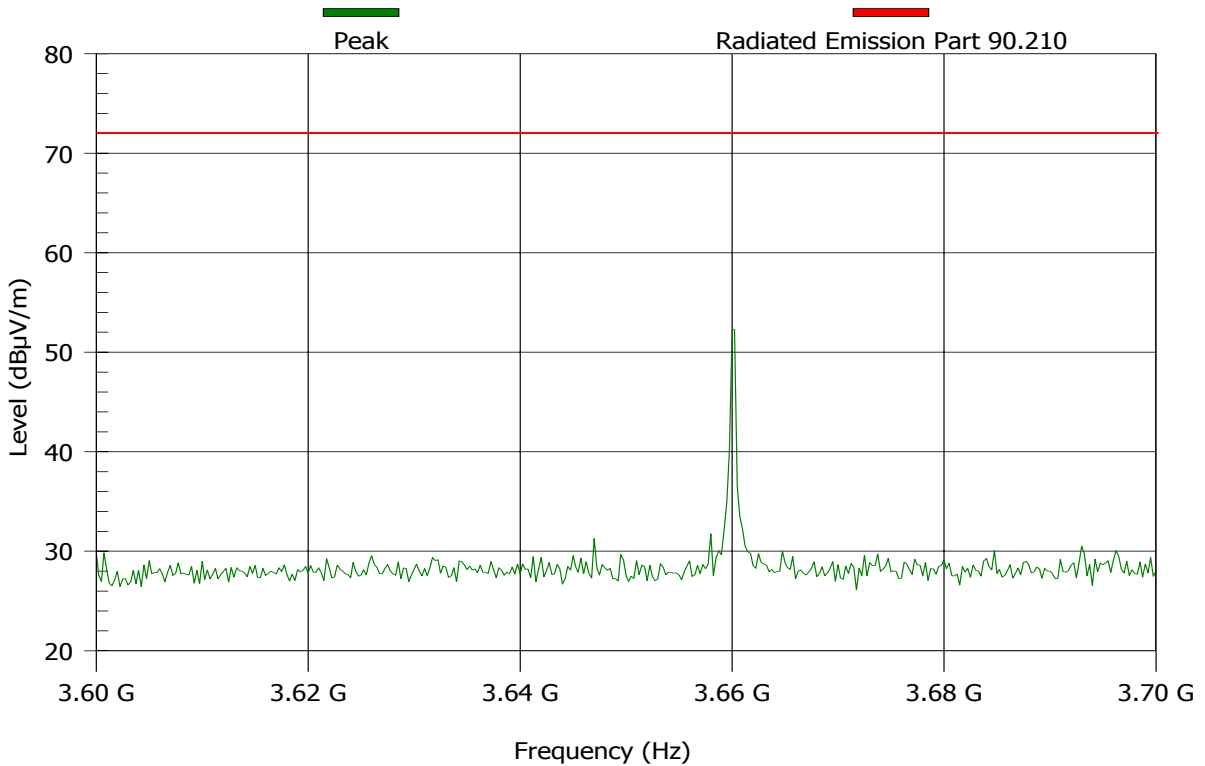

**MAXIMUM RESULT DEVIATION:**

Detect all peaks above 6 dB below the limit line with a maximum of 6 peaks.

Frequency (MHz)	PK MaxHold (dBµV/m)	PK Limit (dBµV/m)	Result	Angle (degrees)	Height (m)	H/V
3659.803	53.2	72.4	Pass	120	1	V

Test Results Plot No 45

**FCC 90.210 3.6-3.7GHz 3rd Harmonic HOR**

Test & EUT General Information		Receiver Setting	
EUT Name:	FP-200 SAG-915MHz	Spect Analyzer	S.A HP 8593E
S/N:	2	Ref. Level:	90 dB $\mu$ V
Date of Test:		RBW:	100 kHz
Test Engineer:		VBW:	1000 kHz
Antenna:	EMCO 3105 1-18GHz	Sweep Time:	Auto: 30 ms
Polarization:	Horizontal	Pre Amplifier	ELISRA AMP 2-6 GHz

TEST REMARKS:29-08-05  
3rd Harmonic Test HOR.  
S/N=2

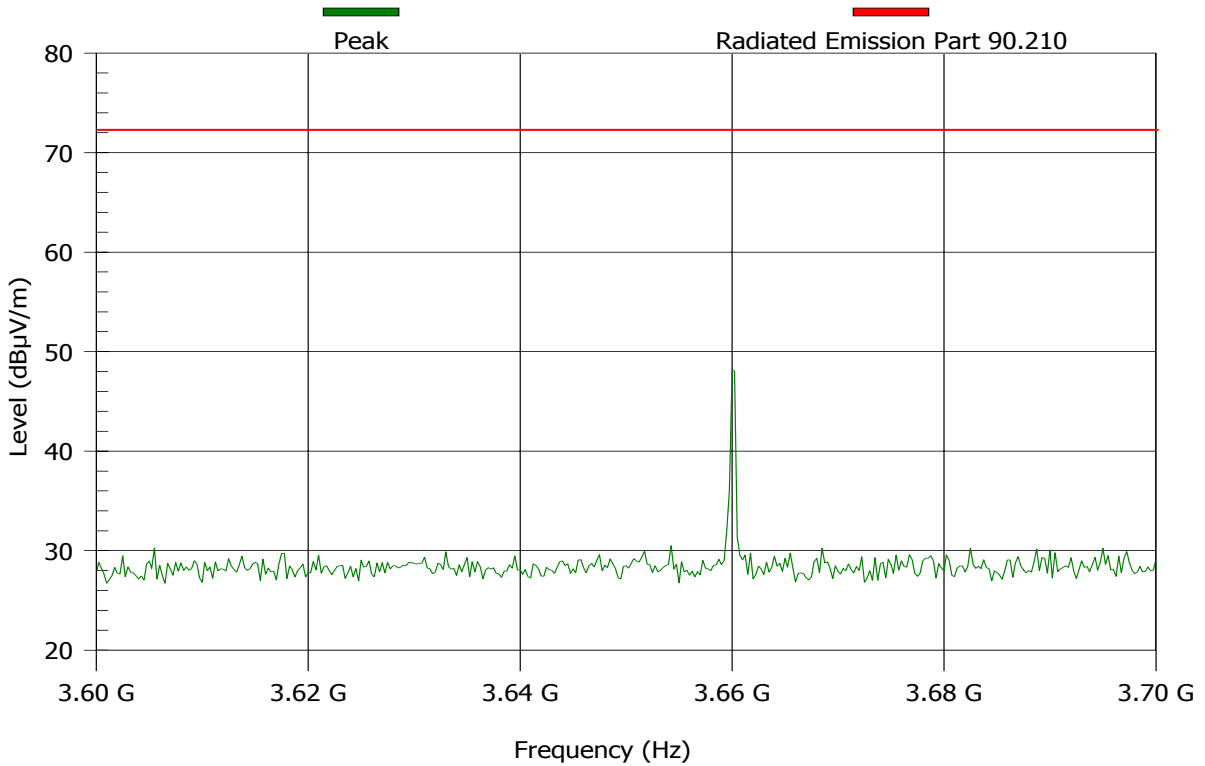

**MAXIMUM RESULT DEVIATION:**

Detect all peaks above 6 dB below the limit line with a maximum of 6 peaks.

Frequency (MHz)	PK MaxHold (dB $\mu$ V/m)	PK Limit (dB $\mu$ V/m)	Result	Angle (degrees)	Height (m)	H/V
3659.802	49.3	72.4	Pass	240	1.6	H



Test Results Plot No 46

**FCC 90.210 4.5-4.6GHz 4th Harmonic VER**

Test & EUT General Information		Receiver Setting	
EUT Name:	FP-200 SAG-915MHz	Spect Analyzer	S.A HP 8593E
S/N:	2	Ref. Level:	90 dB $\mu$ V
Date of Test:		RBW:	100 kHz
Test Engineer:		VBW:	1000 kHz
Antenna:	EMCO 3105 1-18GHz	Sweep Time:	Auto: 30 ms
Polarization:	Vertical	Pre Amplifier	ELISRA AMP 2-6 GHz

TEST REMARKS:29-08-05  
4th Harmonic Test VER.  
S/N=2

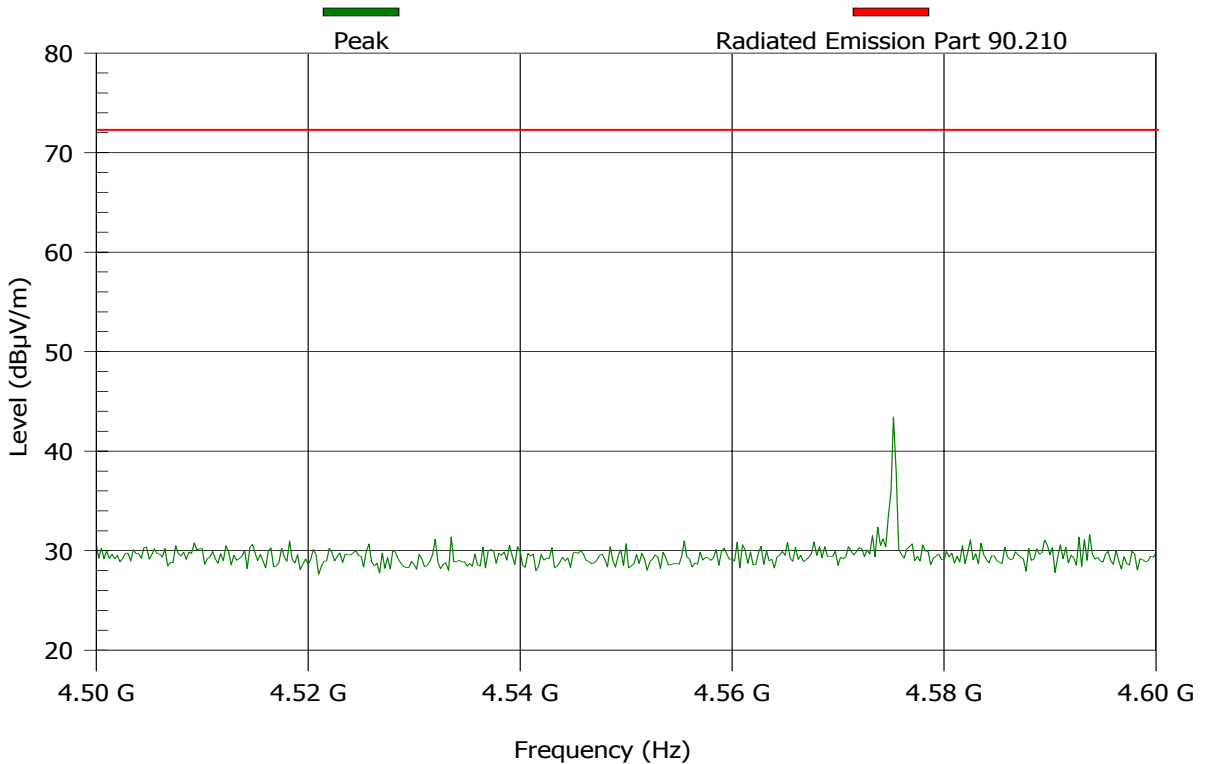

**MAXIMUM RESULT DEVIATION:**

Detect all peaks above 6 dB below the limit line with a maximum of 6 peaks.

Frequency (MHz)	PK MaxHold (dB $\mu$ V/m)	PK Limit (dB $\mu$ V/m)	Result	Angle (degrees)	Height (m)	H/V
4574.759	44.4	72.4	Pass	180	1	V

Test Results Plot No 47

**FCC 90.210 4.5-4.6GHz 4th Harmonic HOR**

Test & EUT General Information		Receiver Setting	
EUT Name:	FP-200 SAG-915MHz	Spect Analyzer	S.A HP 8593E
S/N:	2	Ref. Level:	90 dB $\mu$ V
Date of Test:		RBW:	100 kHz
Test Engineer:		VBW:	1000 kHz
Antenna:	EMCO 3105 1-18GHz	Sweep Time:	Auto: 30 ms
Polarization:	Horizontal	Pre Amplifier	ELISRA AMP 2-6 GHz

TEST REMARKS:29-08-05  
4th Harmonic Test HOR.  
S/N=2

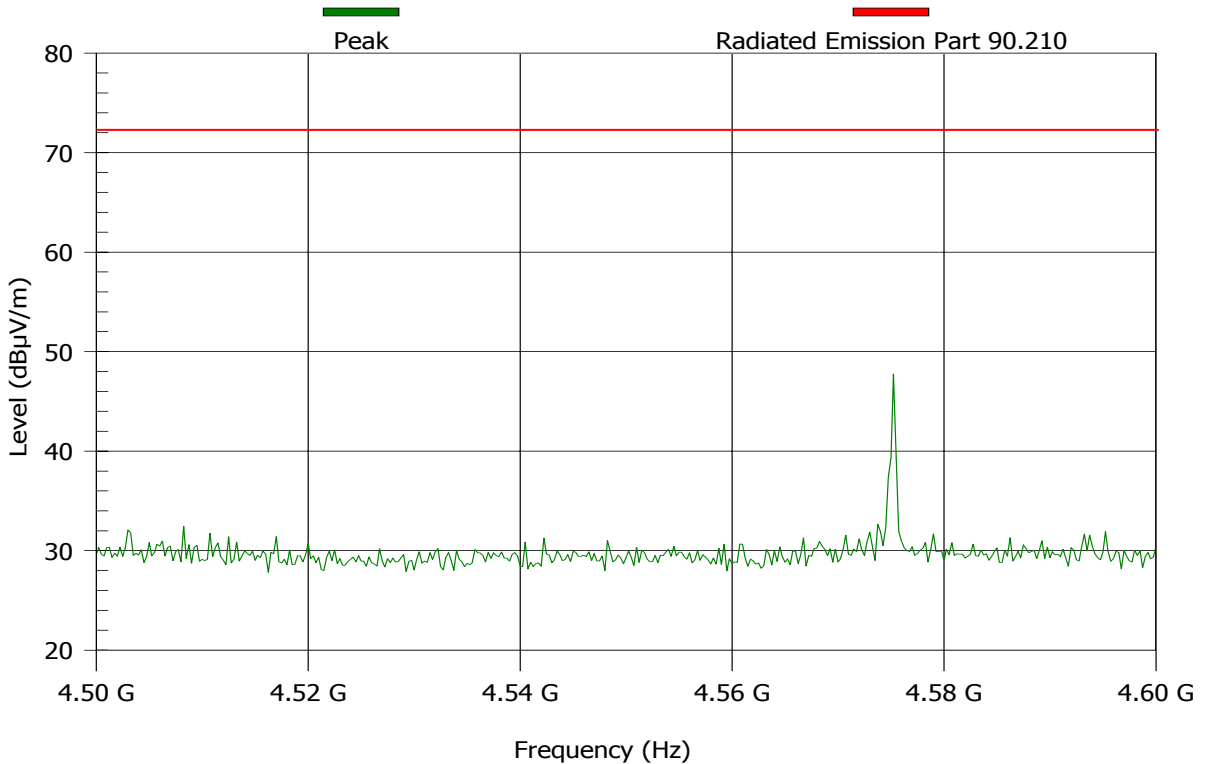

**MAXIMUM RESULT DEVIATION:**

Detect all peaks above 6 dB below the limit line with a maximum of 6 peaks.

Frequency (MHz)	PK MaxHold (dB $\mu$ V/m)	PK Limit (dB $\mu$ V/m)	Result	Angle (degrees)	Height (m)	H/V
4574.76	48.4	72.4	Pass	240	1.6	H

Test Results Plot No 48

**FCC 90.210 5.4-5.5GHz 5th Harmonic VER**

Test & EUT General Information		Receiver Setting	
EUT Name:	FP-200 SAG-915MHz	Spect Analyzer	S.A HP 8593E
S/N:	2	Ref. Level:	90 dB $\mu$ V
Date of Test:		RBW:	100 kHz
Test Engineer:		VBW:	1000 kHz
Antenna:	EMCO 3105 1-18GHz	Sweep Time:	Auto: 30 ms
Polarization:	Vertical	Pre Amplifier	ELISRA AMP 2-6 GHz

TEST REMARKS:29-08-05  
5th Harmonic Test VER.  
S/N=2

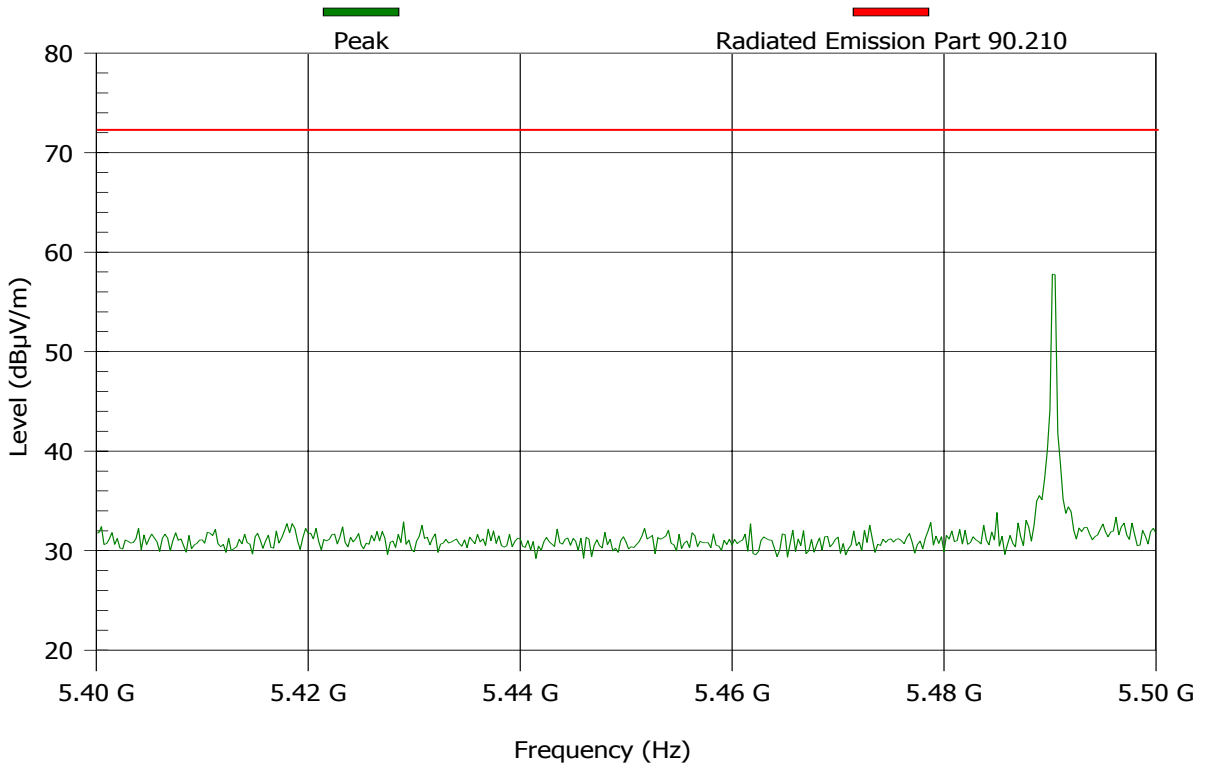

**MAXIMUM RESULT DEVIATION:**

Detect all peaks above 6 dB below the limit line with a maximum of 6 peaks.

Frequency (MHz)	PK MaxHold (dB $\mu$ V/m)	PK Limit (dB $\mu$ V/m)	Result	Angle (degrees)	Height (m)	H/V
5489.707	58.4	72.4	Pass	120	1.3	V

Test Results Plot No 49

**FCC 90.210 5.4-5.5GHz 5th Harmonic HOR**

Test & EUT General Information		Receiver Setting	
EUT Name:	FP-200 SAG-915MHz	Spect Analyzer	S.A HP 8593E
S/N:	2	Ref. Level:	90 dB $\mu$ V
Date of Test:		RBW:	100 kHz
Test Engineer:		VBW:	1000 kHz
Antenna:	EMCO 3105 1-18GHz	Sweep Time:	Auto: 30 ms
Polarization:	Horizontal	Pre Amplifier	ELISRA AMP 2-6 GHz

TEST REMARKS:29-08-05  
5th Harmonic Test HOR.  
S/N=2

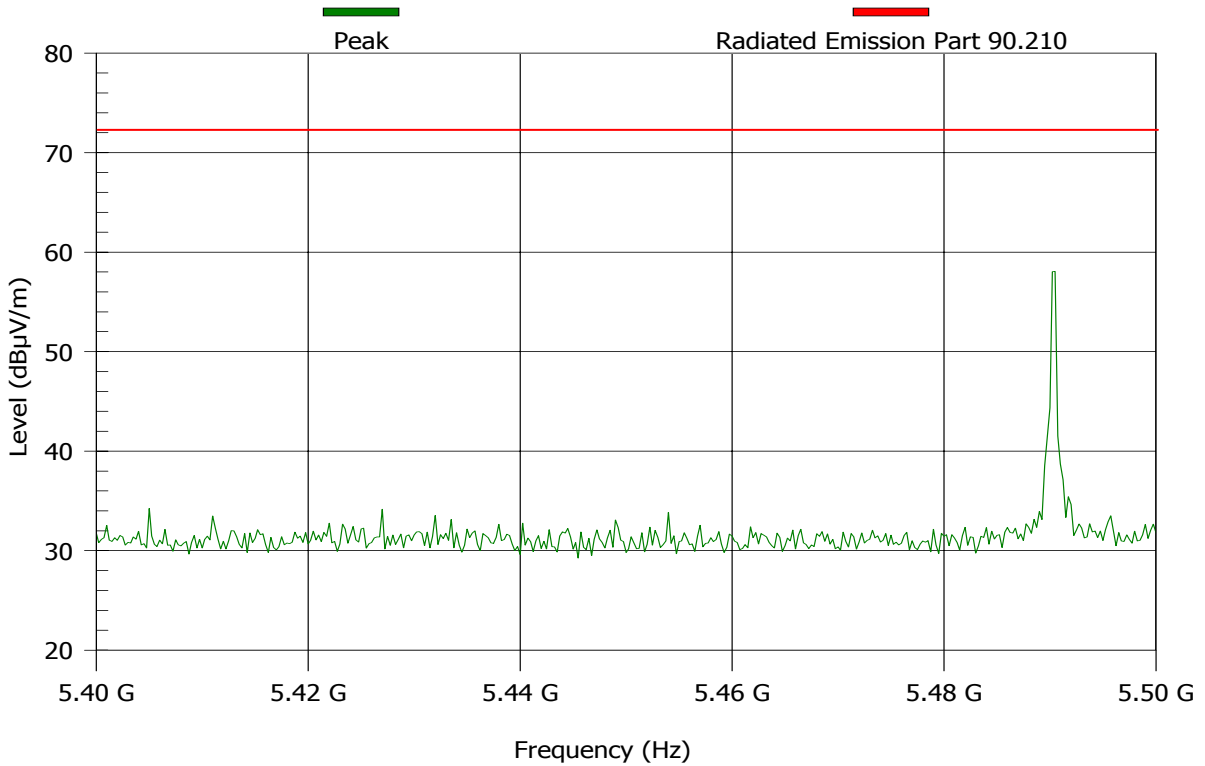

**MAXIMUM RESULT DEVIATION:**

Detect all peaks above 6 dB below the limit line with a maximum of 6 peaks.

Frequency (MHz)	PK MaxHold (dB $\mu$ V/m)	PK Limit (dB $\mu$ V/m)	Result	Angle (degrees)	Height (m)	H/V
5489.697	58.7	72.4	Pass	120	1.6	H

Test Results Plot No 50

**FCC 90.210 7.3-7.4GHz 6th Harmonic VER**

Test & EUT General Information		Receiver Setting	
EUT Name:	FP-200 SAG-915MHz	Spect Analyzer	S.A HP 8593E
S/N:	2	Ref. Level:	90 dB $\mu$ V
Date of Test:		RBW:	100 kHz
Test Engineer:		VBW:	1000 kHz
Antenna:	EMCO 3105 1-18GHz	Sweep Time:	Auto: 30 ms
Polarization:	Vertical	Pre Amplifier	ELISRA AMP 6-18 GHz

TEST REMARKS:29-08-05  
6th Harmonic Test VER.  
S/N=2

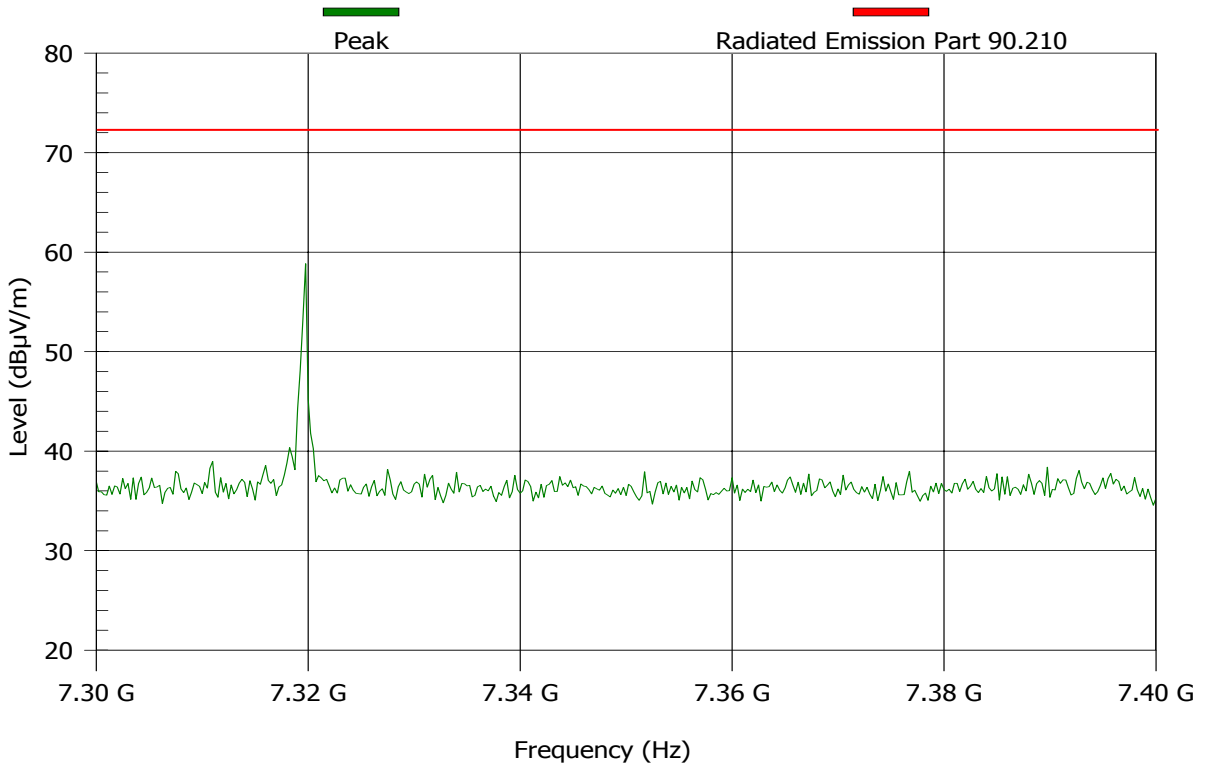

**MAXIMUM RESULT DEVIATION:**

Detect all peaks above 6 dB below the limit line with a maximum of 6 peaks.

Frequency (MHz)	PK MaxHold (dB $\mu$ V/m)	PK Limit (dB $\mu$ V/m)	Result	Angle (degrees)	Height (m)	H/V
7319.58	59.3	72.4	Pass	180	1.3	V

Test Results Plot No 51  
**FCC 90.210 7.3-7.4GHz 6th Harmonic HOR**

Test & EUT General Information		Receiver Setting	
EUT Name:	FP-200 SAG-915MHz	Spect Analyzer	S.A HP 8593E
S/N:	2	Ref. Level:	90 dBµV
Date of Test:		RBW:	100 kHz
Test Engineer:		VBW:	1000 kHz
Antenna:	EMCO 3105 1-18GHz	Sweep Time:	Auto: 30 ms
Polarization:	Horizontal	Pre Amplifier	ELISRA AMP 6-18 GHz

TEST REMARKS:29-08-05  
6th Harmonic Test HOR.  
S/N=2

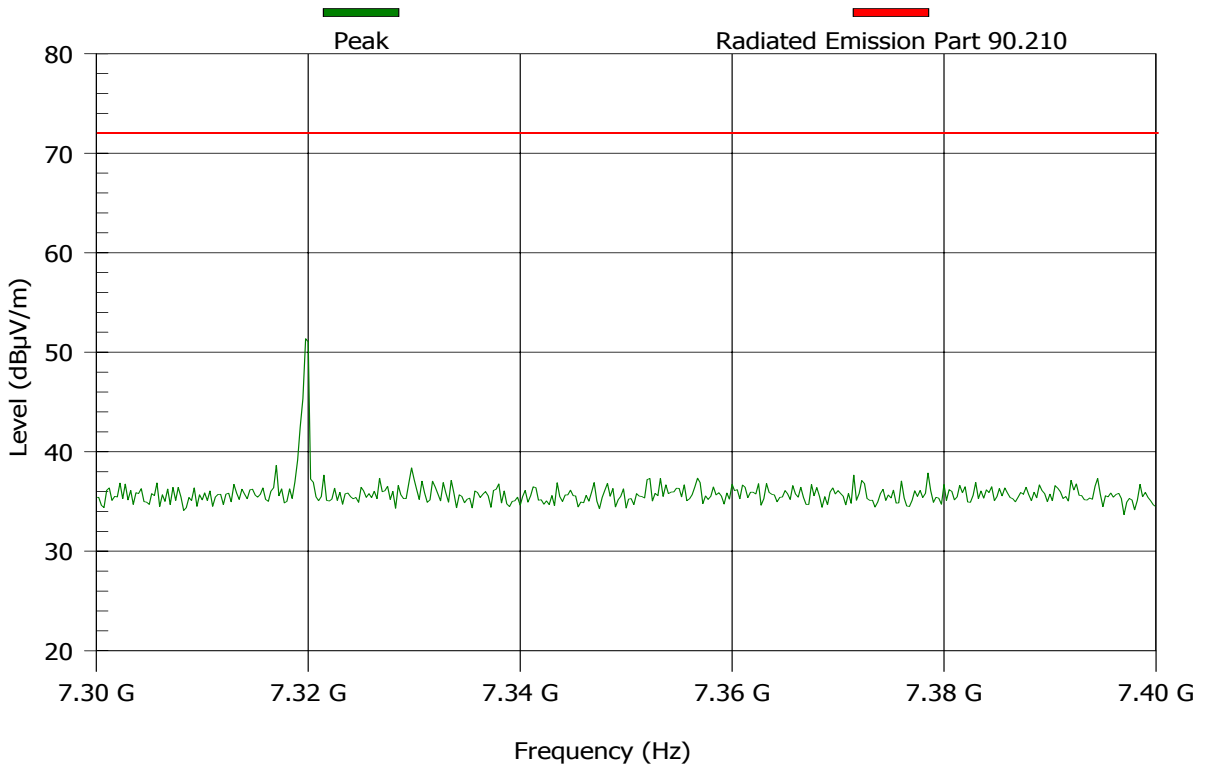

**MAXIMUM RESULT DEVIATION:**

Detect all peaks above 6 dB below the limit line with a maximum of 6 peaks.

Frequency (MHz)	PK MaxHold (dBµV/m)	PK Limit (dBµV/m)	Result	Angle (degrees)	Height (m)	H/V
7319.592	52.4	72.4	Pass	180	1.6	H

Test Results Plot No 52  
**FCC 90.210 ERP 1.8-1.9GHz 2nd Harmonic VER**

Test & EUT General Information		Receiver Setting	
EUT Name:	FP-200 SAG-915MHz	Spect Analyzer	S.A HP 8593E
S/N:	2	Ref. Level:	90 dBµV
Date of Test:		RBW:	100 kHz
Test Engineer:		VBW:	1000 kHz
Antenna:	EMCO 3105 1-18GHz	Sweep Time:	Auto: 30 ms
Polarization:	Vertical	Pre Amplifier	pre amp 1GHz-4GHz

TEST REMARKS:29-08-05  
ERP 1830MHz VER.

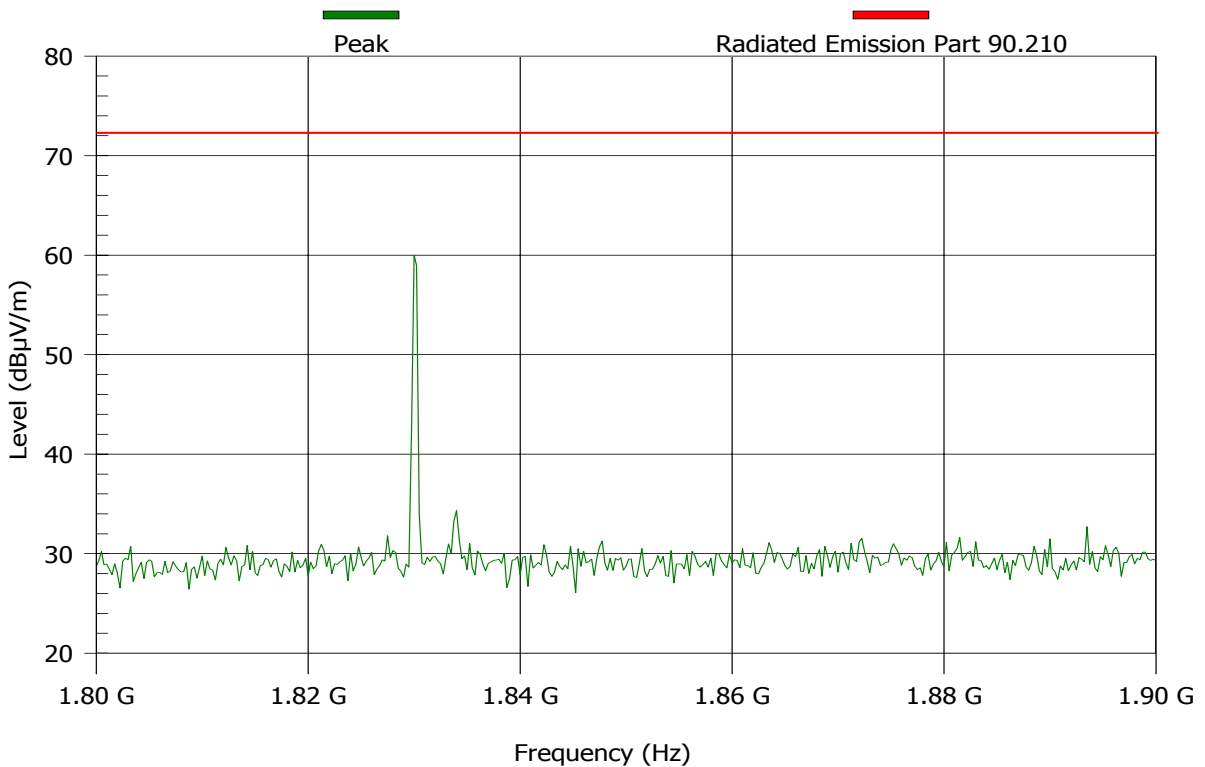

**MAXIMUM RESULT DEVIATION:**

Detect all peaks above 6 dB below the limit line with a maximum of 6 peaks.

Frequency (MHz)	PK MaxHold (dBµV/m)	PK Limit (dBµV/m)	Result	Angle (degrees)	Height (m)	H/V
1830	60	72.4	Pass	0	1	V

Test Results Plot No 53  
**FCC 90.210 ERP 3.6-3.7GHz 3rd Harmonic HOR**

Test & EUT General Information		Receiver Setting	
EUT Name:	FP-200 SAG-915MHz	Spect Analyzer	S.A HP 8593E
S/N:	2	Ref. Level:	90 dBµV
Date of Test:		RBW:	100 kHz
Test Engineer:		VBW:	1000 kHz
Antenna:	EMCO 3105 1-18GHz	Sweep Time:	Auto: 30 ms
Polarization:	Horizontal	Pre Amplifier	ELISRA AMP 2-6 GHz

TEST REMARKS:29-08-05  
ERP 3660.25MHz HOR.

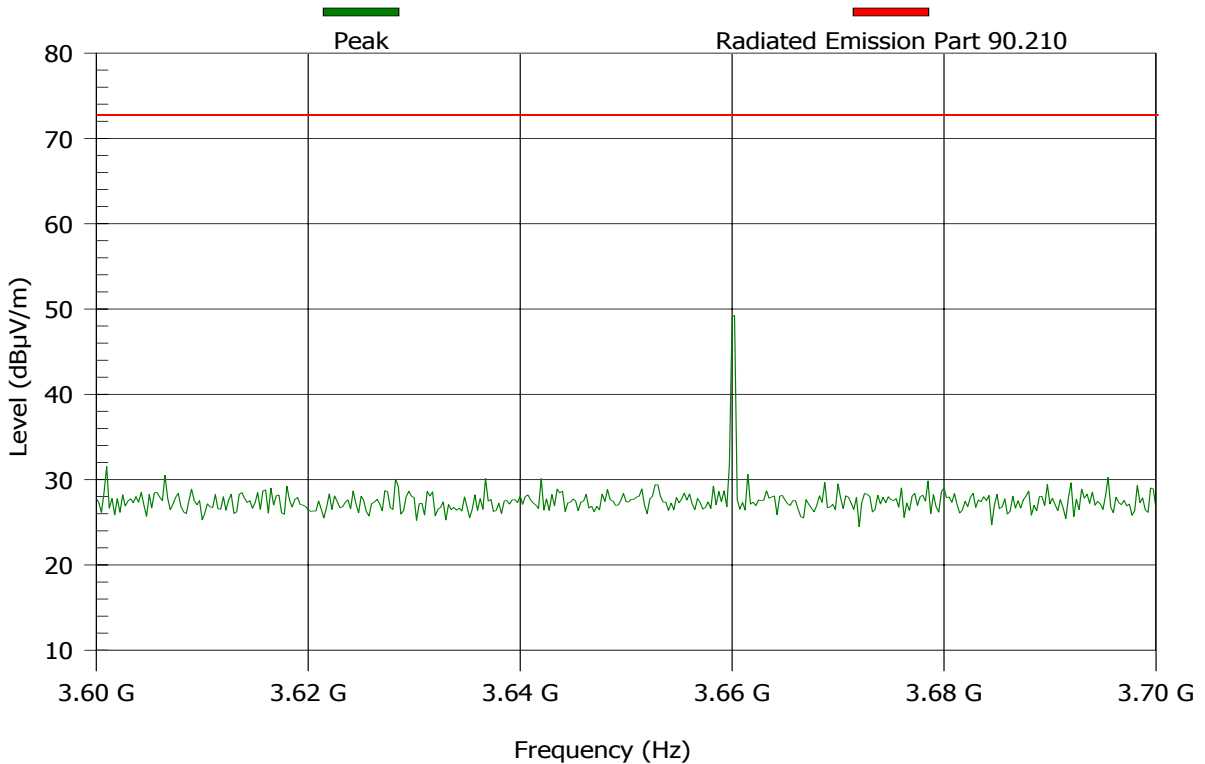

**MAXIMUM RESULT DEVIATION:**

Detect all peaks above 6 dB below the limit line with a maximum of 6 peaks.

Frequency (MHz)	PK MaxHold (dBµV/m)	PK Limit (dBµV/m)	Result	Angle (degrees)	Height (m)	H/V
3660.25	49.3	72.4	Pass	0	1.6	H



Test Results Plot No 54  
**FCC 15.109 30-1000MHz Receive - 915MHz**

Test & EUT General Information		Receiver Setting	
EUT Name:	FP-200 SAG-915MHz	Spect Analyzer	S.A HP 8593E
S/N:	2	Ref. Level:	90 dB $\mu$ V
Date of Test:		RBW:	120 kHz
Test Engineer:		VBW:	300 kHz
Antenna:	Frankonia BTA-L_A 3m	Sweep Time:	Auto: 202.08 ms
Polarization:	Horizontal and Vertical	Pre Amplifier	LNA MITEQ 0.01-1GHz No-3

TEST REMARKS:01-09-2005  
SN=2

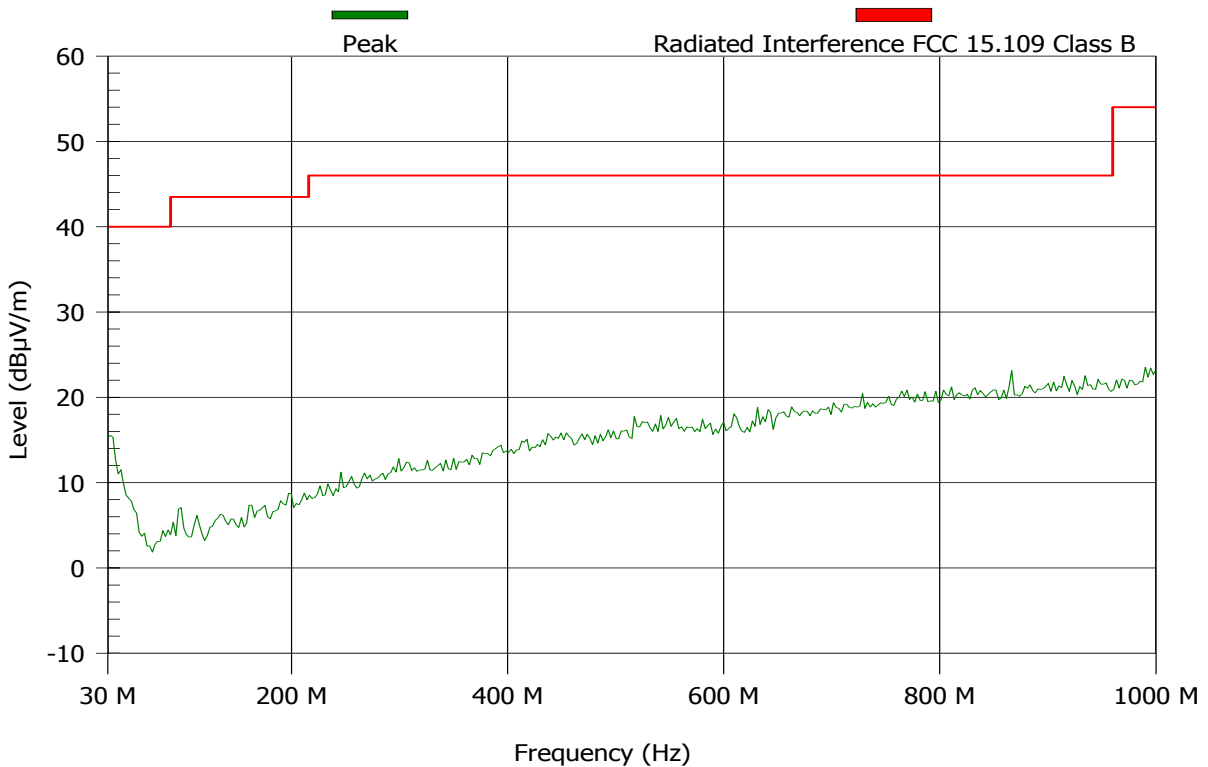

**MAXIMUM RESULT DEVIATION:**

Detect all peaks above 6 dB below the limit line with a maximum of 6 peaks.  
None

Test Results Plot No 55  
**FCC 15.109 1-2.8GHz Receive - 915MHz**

Test & EUT General Information		Receiver Setting	
EUT Name:	FP-200 SAG-915MHz	Spect Analyzer	S.A HP 8593E
S/N:	2	Ref. Level:	90 dB $\mu$ V
Date of Test:		RBW:	1000 kHz
Test Engineer:		VBW:	1000 kHz
Antenna:	ARA DRG-118/A 1-18GHz 1319	Sweep Time:	Auto: 36 ms
Polarization:	Horizontal and Vertical	Pre Amplifier	pre amp 1GHz-4GHz

TEST REMARKS:01-09-2005  
SN=2

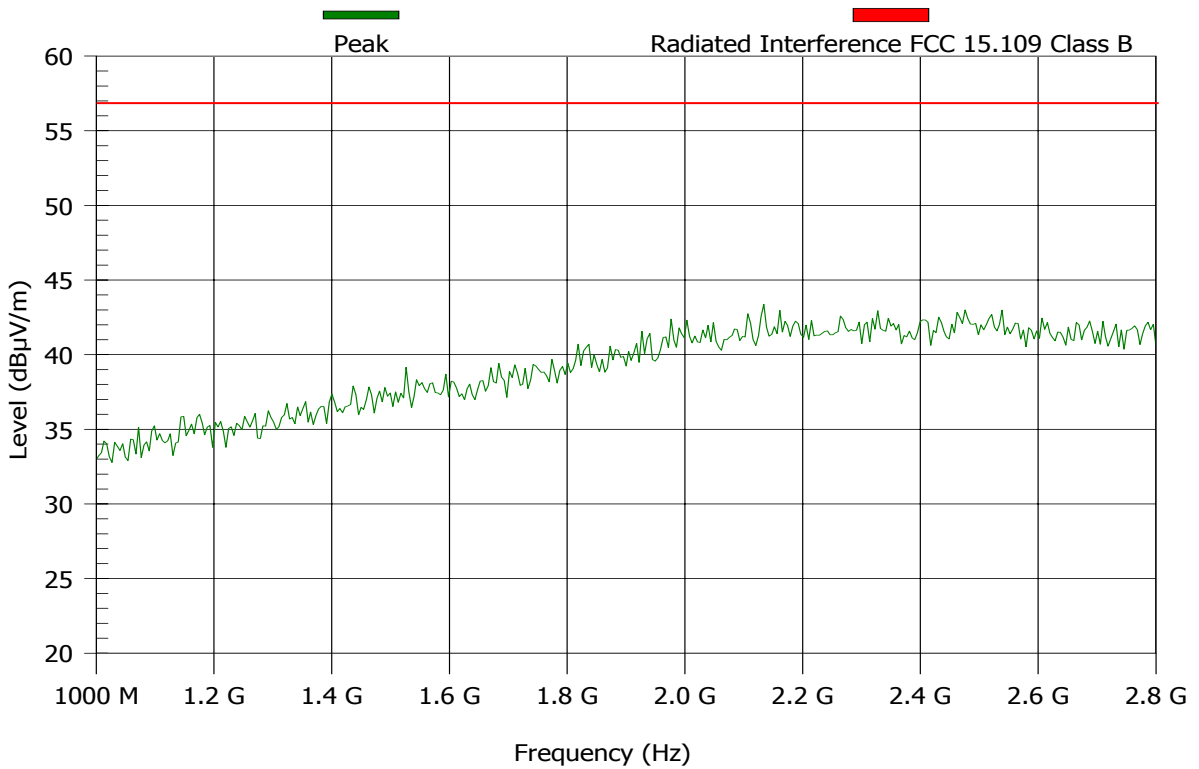

Test Results Plot No 56  
**FCC 15.109 2.8-6GHz Receive - 915MHz**

Test & EUT General Information		Receiver Setting	
EUT Name:	FP-200 SAG-915MHz	Spect Analyzer	S.A HP 8593E
S/N:	2	Ref. Level:	90 dB $\mu$ V
Date of Test:		RBW:	120 kHz
Test Engineer:		VBW:	300 kHz
Antenna:	ARA DRG-118/A 1-18GHz 1319	Sweep Time:	Auto: 666.67 ms
Polarization:	Horizontal and Vertical	Pre Amplifier	ELISRA AMP 2-6 GHz

TEST REMARKS:01-09-2005  
SN=2

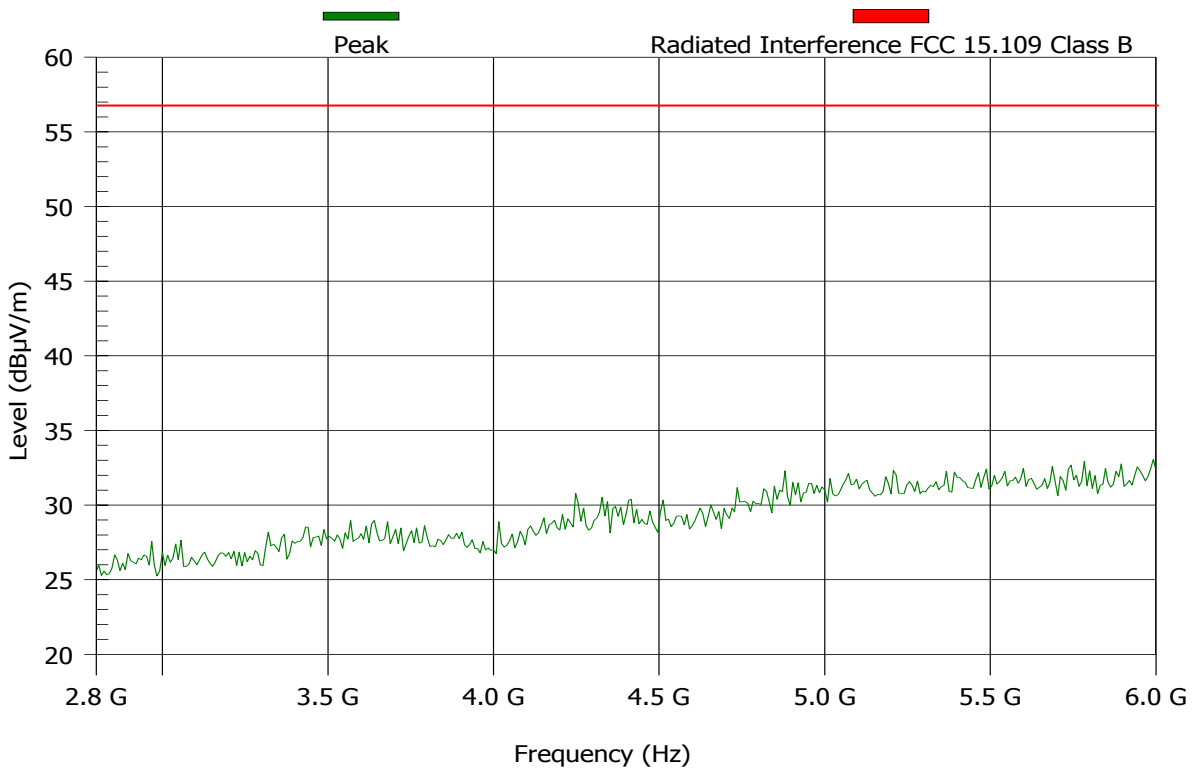

Test Results Plot No 57  
**FCC 15.109 30-1000MHz Stby**

Test & EUT General Information		Receiver Setting	
EUT Name:	FP-200 SAG-915MHz	Spect Analyzer	S.A HP 8593E
S/N:	2	Ref. Level:	90 dB $\mu$ V
Date of Test:		RBW:	120 kHz
Test Engineer:		VBW:	300 kHz
Antenna:	Frankonia BTA-L_A 3m	Sweep Time:	Auto: 202.08 ms
Polarization:	Horizontal and Vertical	Pre Amplifier	LNA MITEQ 0.01-1GHz No-3

TEST REMARKS:01-09-2005  
SN=2

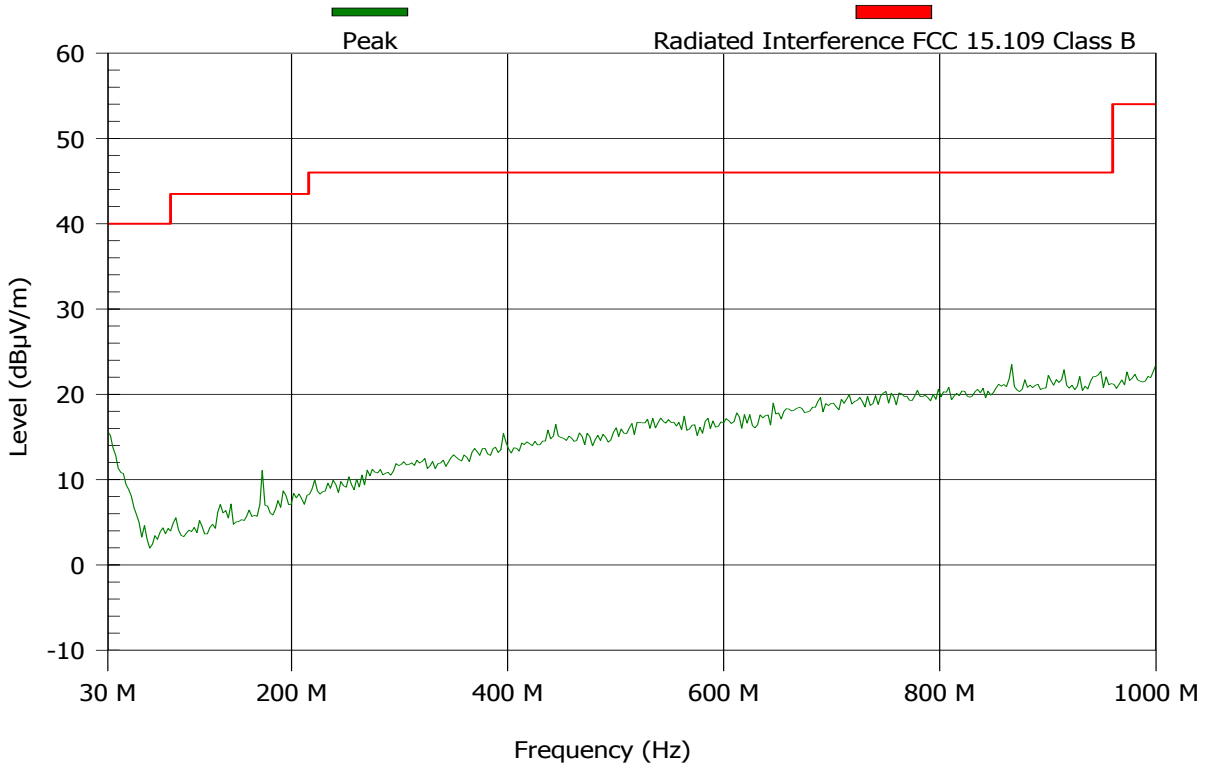

**MAXIMUM RESULT DEVIATION:**

Detect all peaks above 6 dB below the limit line with a maximum of 6 peaks.  
None

Test Results Plot No 58  
**FCC 15.109 1-2.8GHz Stby**

Test & EUT General Information		Receiver Setting	
EUT Name:	FP-200 SAG-915MHz	Spect Analyzer	S.A HP 8593E
S/N:	2	Ref. Level:	90 dB $\mu$ V
Date of Test:		RBW:	1000 kHz
Test Engineer:		VBW:	1000 kHz
Antenna:	ARA DRG-118/A 1-18GHz 1319	Sweep Time:	Auto: 36 ms
Polarization:	Horizontal and Vertical	Pre Amplifier	pre amp 1GHz-4GHz

TEST REMARKS:01-09-2005  
SN=2

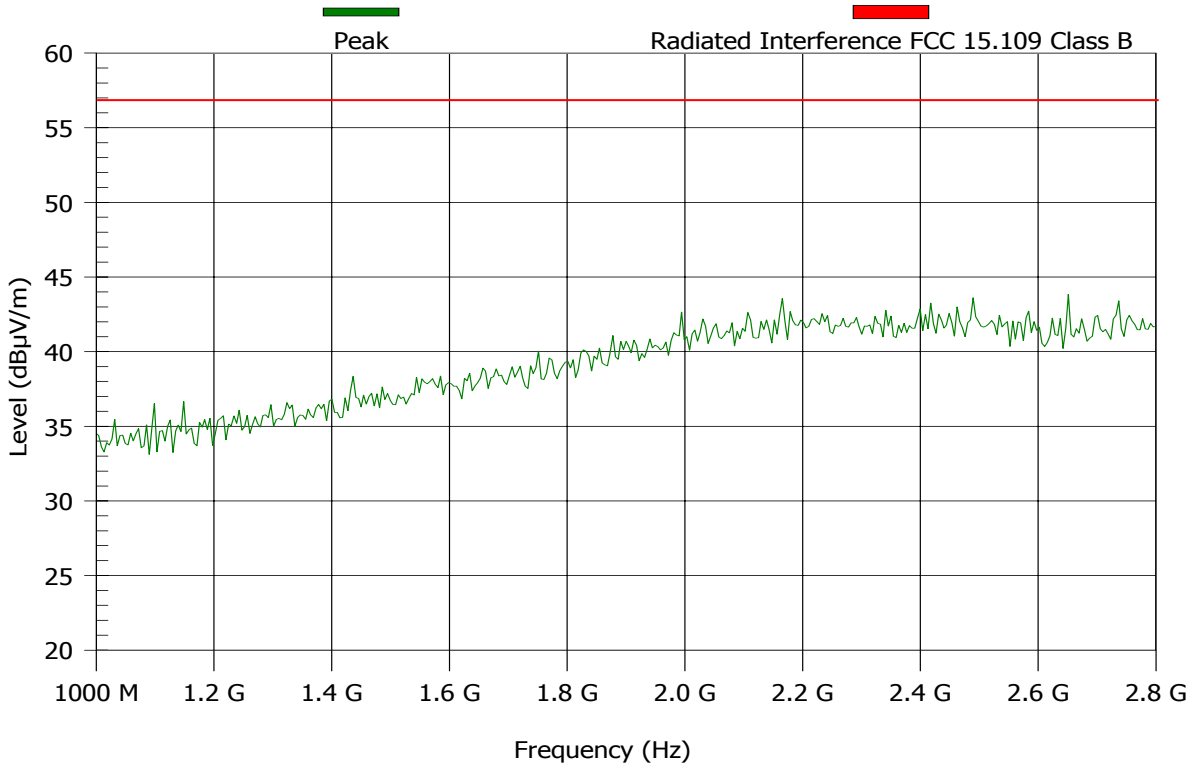

Test Results Plot No 59  
**FCC 15.109 2.8-6GHz Stby**

Test & EUT General Information		Receiver Setting	
EUT Name:	FP-200 SAG-915MHz	Spect Analyzer	S.A HP 8593E
S/N:	2	Ref. Level:	90 dB $\mu$ V
Date of Test:		RBW:	120 kHz
Test Engineer:		VBW:	300 kHz
Antenna:	ARA DRG-118/A 1-18GHz 1319	Sweep Time:	Auto: 666.67 ms
Polarization:	Horizontal and Vertical	Pre Amplifier	ELISRA AMP 2-6 GHz

TEST REMARKS:01-09-2005  
SN=2

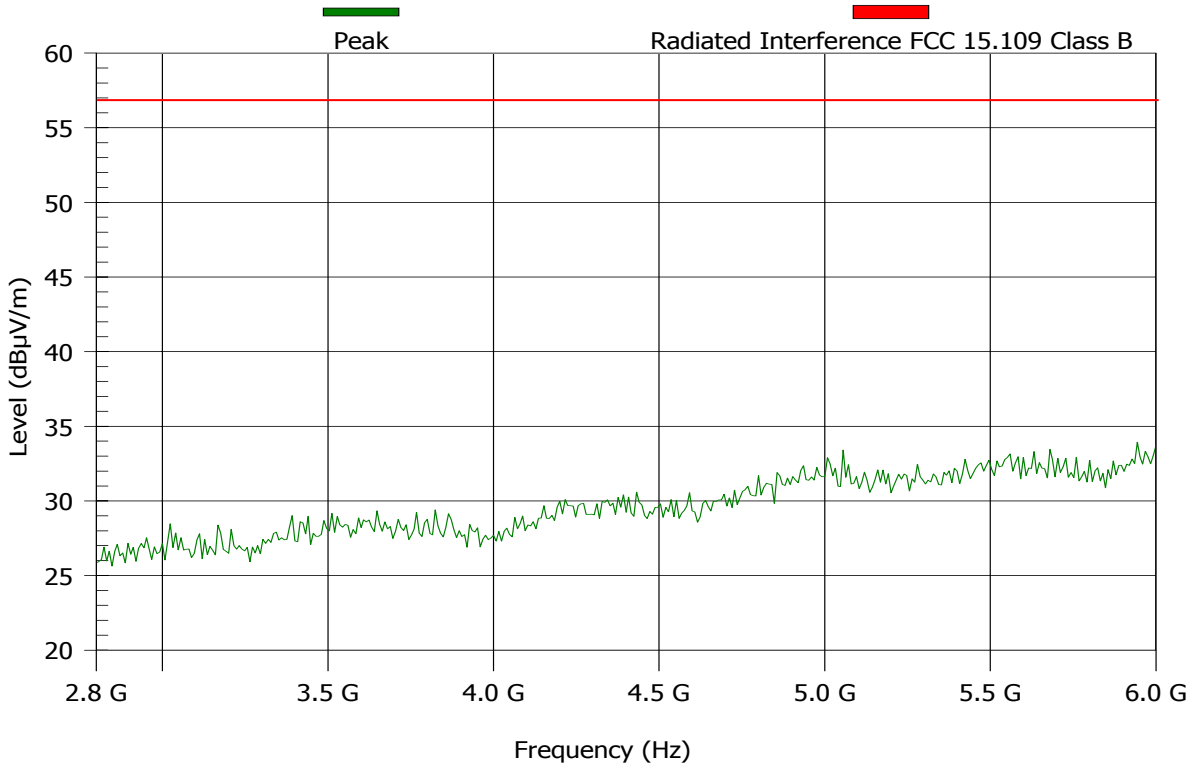

## 17 CORRECTION FACTORS

Correction Factor for **line impedance stabilization network** model DC-AC-20A-01

Frequency (KHz)	Correction Factor (db)
10	4.4
20	1.6
30	0.8
40	0.4
50	0.3
60	0.25
70	0.15
100	0.1
200	0

DOUBLE RIDGE HORN Model 3105 S/N:002-C3-3D 2052 Antenna Factor

Frequency (MHz)	Ant. Factor (db/m)
1000	24.4
2000	26.2
3000	30
4000	32.6
5000	33.8
6000	34.9
7000	36.2
8000	36.9
9000	37.8
10000	38.4
11000	39.1
12000	40.1
13000	42
14000	40.6
15000	39.3
16000	40.3

## Antenna Factor for broadband antenna model BTA-L S/N:002-C3-3D 980045L

Frequency (KHz)	Ant. Factor (db/m)	Frequency (KHz)	Ant. Factor (db/m)
30	19.05	300	14.35
32	19.13	310	14.28
34	18.74	320	14.43
36	18.03	330	14.13
38	16.61	340	14.48
40	15.44	350	14.89
45	13.66	360	15.12
50	11.52	370	15.70
55	10.04	380	15.78
60	7.68	390	16.22
65	6.11	400	16,45
70	5.47	425	16.99
75	5.98	450	17.59
80	6.86	475	17.28
85	7.20	500	17.69
90	7.47	525	18.91
95	7.23	550	19.06
100	7.20	575	18.20
105	7.30	600	18.87
110	7.37	625	18.81
115	7.02	650	19.64
120	6.82	675	19.92
125	7.05	700	20.66
130	7.83	725	21.08
135	9.61	750	21.53
140	7.93	775	22.39
145	8.03	800	22.66
150	8.29	825	22.87
160	8.72	850	22.65
170	9.18	875	23.12
180	9.05	900	23.70
190	9.80	925	23.40
200	10.61	950	23.43
210	10.34	975	23.30
220	11.21	1000	24.02
230	11.69		
240	11.62		
250	11.85		
260	12.45		
270	13.16		
280	13.48		
290	13.74		



## 18 Abbreviations and Acronyms

The following abbreviations and acronyms are applicable in this document

BW	Bandwidth
Db	Decibel
EMI	Electromagnetic interference
E.U.T	Equipment under test
LISN	Line impedance stabilization network
RBW	Resolution band width
S/N	Serial number
VBW	Video bandwidth

a.