

FP-102TA - ASTM V6 Transponder

Telematics Wireless' FP-102 software programmable transponder, serves as the in vehicle component. It is a small size unit that communicates with roadside readers at a data rate of 500 Kb/sec, using ASTM v6 Slotted-Aloha Time Division Multiple Access (TDMA) protocol. It uses ASK modulation and operates in the 902-928 MHz ISM band.

The FP-102 is a read & write transponder providing three levels of programmable memory:

- Factory Programmed
- Agency Programmed
- 256 bits Scratchpad Read/Write

An optional 32 Kbytes on board RAM may be included for additional applications.

The FP-102 transponder has an audible (buzzer) and visual (3 color LEDs) driver interface, enabling various transaction indications.

The FP-102 is powered from an internal, long life, Lithium battery enabling more than 6 years of operation. The unit provides the roadside reader with battery status.



Architecture:

The FP-102 transponder's architecture is based on a RISC and a proprietary *FastPass*TM ASIC.

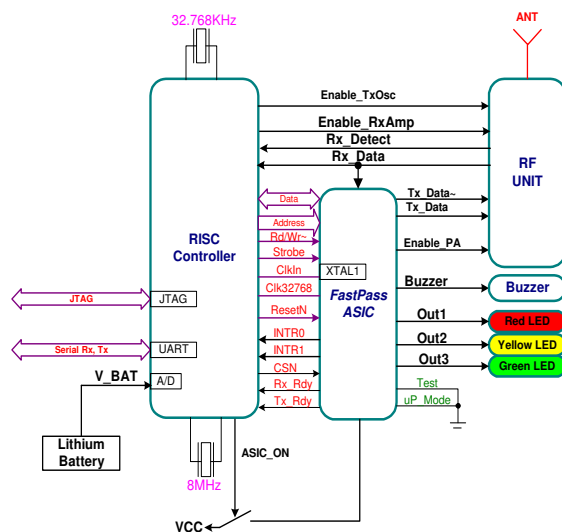

This architecture enables the flexibility and programmability of the transponder for future applications and customer specific requirements.



Transponder Characteristics:

- Slotted Aloha protocol –compatible with ASTM v6.
- Physical Layer compatible with ASTM PS111-98
- Transmit & Receive frequencies within the ISM band 902–928 MHz.
- Transmit and receive data rate of 500 Kb/sec
- Built-in antenna.
- Active Transmitter provides superior immunity to interference.
- Very low spurious and harmonics radiation.
- Driver interface by means of 3 colored LEDs (Green, Yellow, Red) and a buzzer with programmable alarms.
- Long life Lithium battery together with a state of the art power supervision circuitry enable more than 6 years of operation.
- Software programmable
- Programmable Link Validation Sequence Generator.
- Programmable Agency Codes
- Small Size: 88x62x12 (LxWxD) mm.
- Light weight: 55 grams
- Easy mounting/demounting on the vehicle front windshield.
- Performance resistant to vibration, shock, temperatures and humidity prevailing in a vehicular atmosphere.

Applications:

- Toll collection - Lane based and free flow.
- Fee Payments – Drive Through, carwash.
- Parking and curbside parking payments.
- Gas stations and convenience payments.
- Access control to restricted areas, urban centers.
- Border crossing