

FCC TEST REPORT No. 13/235	2013
for 47 CFR Part 90	September, 30

Model name:	2WMMR
Product description	The Reader of the Water Meter Part 15 Class B Computing Device Peripheral
Equipment Class	Licensed Non-Broadcast Station Transmitter
FCC ID	NTA2WMMR1
Applicant	Telematics Wireless Ltd., Israel
Manufacturer	Telematics Wireless Ltd., Israel

*The results in this report apply only to the samples tested.
Reproduction or copying of this report or its any part may only be made
with the prior
written approval of PE TC “Omega”*

PUBLIC ENTERPRISE
TESTING CENTER
“OMEGA”
Certificate of accreditation
№ 2H339 from 18.05.11

29 Vakulenchuk str., Sevastopol,
99053, Crimea, Ukraine, P.O.B.-37
phone: +380 692 53 70 72
fax: +380 692 46 96 79
e-mail: stcomega@stc-omega.biz

Approved by
Sergey Bogach,
Chief TC of PE TC “OMEGA”



Table of contents

1 EQUIPMENT UNDER TEST	3
<u>1.1 BASIC DESCRIPTION</u>	3
<u>1.2 TECHNICAL CHARACTERISTICS DECLARED BY MANUFACTURER</u>	3
<u>1.3 PHOTOS</u>	4
2 GENERAL INFORMATION ABOUT TESTS	7
<u>2.1 TEST PROGRAM AND RESULTS OF THE TESTS</u>	7
<u>2.2 TEST MANNER</u>	7
<u>2.3 TEST CONDITIONS AND TEST MODES</u>	7
<u>2.4 TEST EQUIPMENT USED</u>	8
<u>2.5 MEASUREMENT UNCERTAINTY</u>	8
<u>2.6 PHOTO OF TEST SITE</u>	9
3 REPORT OF MEASUREMENTS AND EXAMINATIONS OF THE TRANSMITTER	11
<u>3.1 EMISSION MASK</u>	11
<u>3.2 CONDUCTED SPURIOUS EMISSIONS</u>	14
<u>3.3 RADIATED SPURIOUS EMISSIONS</u>	19
<u>3.4 TRANSIENT STABILITY</u>	25
<u>3.5 FREQUENCY STABILITY VS POWER SUPPLY</u>	29
<u>3.6 FREQUENCY STABILITY VS TEMPERATURE</u>	31
<u>3.7 OPERATING FREQUENCIES</u>	33
<u>3.8 99% OCCUPIED BANDWIDTH</u>	34
4 REPORT OF MEASUREMENTS AND EXAMINATIONS OF THE RECEIVER	37
<u>4.1 RADIATED EMISSION</u>	37
<u>4.2 ANTENNA POWER CONDUCTED EMISSIONS</u>	41

1 EQUIPMENT UNDER TEST

1.1 Basic description

Equipment Category	
Model name	2WMMR
Destination	a compact RF Receiver/Transmitter unit for Reader of the Water Meter
Configuration	stand-alone device
Serial number	00006

1.2 Technical characteristics declared by manufacturer

Table 1.2.1 Parameters of the Receiver

Parameter	Value
Receive frequency	Programmable 450-470 MHz
Sensitivity (BER 1E-3)	-123 dBm (for 4.8 kbps)
Modulation	4GFSK
Frequency deviation	1.2 kHz
Bit rate	4.8 kbps
Coding	NRZ/Manchester
Frequency stability (including initial stability, temperature and aging)	<0.5 ppm

Table 1.2.2 Parameters of the Transmitter

Parameter	Value
Transmit Frequency	450-470 MHz
Modulation	4GFSK
Bit rate	4.8 kbps
Chip rate	2.4 kChip/sec
Bandwidth	6.25 kHz
Frequency stability (including initial stability, temperature and aging)	<0.5 ppm
Peak Output power	35 dBm or 20dBm (programmable)
Harmonics	< - 65 dBc

Antenna

Antenna type

External

Antenna gain

1 дБи

1.3 Photos

Figure 1.3.1 External photo



Figure 1.3.2 External photo



Figure 1.3.3 External photo



Figure 1.3.4 External photo



Figure 1.3.5 External photo



2 GENERAL INFORMATION ABOUT TESTS

2.1 Test program and results of the tests

Number of test	FCC rule	Description of test	Result (Pass, Fail, N/A)
1	90.210(e)	Emission Mask	Pass
2	90.210(e)	Conducted Spurious Emissions	Pass
3	90.210(e)	Radiated Spurious Emissions	Pass
4	90.214	Transient Frequency Stability	Pass
5	90.213	Frequency Stability with temperature	Pass
6	90.213	Frequency Stability with supply voltage	Pass
7	15.109	Radiated emissions for receivers	Pass
8	15.111	Antenna power conducted emissions for receivers	Pass

Tested by:

tests No. 1,2,4-6: Laboratory engineer

tests No. 3: Laboratory engineer

Boris Trifonov

Vladimir Osaulko

Checked by:

Leading engineer

Fjodor Shubin

2.2 Test manner

2.3 Test conditions and test modes

Operating Temperature: -30 °C to + 85 °C

Storage Temperature: -40 °C to +85 °C

Humidity: Up to 95%

Nominal power source:

- $U_{nom} = +12.0$ V

Extreme temperature:

- minimum temperature $T_{min} = \text{minus } 30$ °C;

- maximum temperature $T_{max} = +85$ °C.

Extreme power source:

- minimum voltage $U_{min} = 10.2$ V

- maximum voltage $U_{max} = 13.8$ V

The frequencies for the testing

Channel, No.	Frequency, MHz
Low	450
Mid	460
High	470

2.4 Test equipment used

№	Name	Model	Inventory or serial No.
1.	EMI Test receiver/spectrum analyzer	R&S ESU-26	100260
2.	Spectrum analyzer	R&S FSV40	105763
3.	Radiocommunication service monitor	R&S CMS-54	100033
4.	Vector Signal Generator	SMJ100A	101127
5.	Signal Generator	SMB100A	100217
6.	Oscilloscope	TDS1002	C041673
7.	Frequency meter	R&S HM8123	100269
8.	Dual directional coupler	778D-012	101895
9.	Attenuator	Agilent 8496B	100103
10.	Attenuator	6N25W	100196
11.	Attenuator	PE7014-10	101692
12.	Detector	Agilent 8471E	100104
13.	RF Trigger	-	111008
14.	Antenna (30 – 1000) MHz	VULB9163	9163244
15.	Antenna (1000 - 6000) MHz	HP11966 model 3115	9903-5701
16.	Antenna (1000 - 6000) MHz	ETS-Lindgren 3117	100200
17.	Antenna (1000 - 6000) MHz	ETS-Lindgren 3117	100201
18.	Digital multimeter	FLUKE 189	89750179
19.	Preamplifier (0.1-18) GHz	Agilent 87405c	MY47010400
20.	Psychrometer	VIT-2	B931
21.	Temperature chamber	KPK - 400 V	015
22.	Shielded Semi-Anechoic Chamber	"DON"	1

All listed above test equipment is calibrated and certified in accordance with established procedure. The equipment has certificates currently in force.

Ancillary equipment

№	Name	Model
1.	Test load	Telematics Wireless RTU_S
2.	Notebook	IBM ThinkPad

2.5 Measurement uncertainty

Parameter	Maximum uncertainty
Radiated emission	± 5.2 dB
Conducted emission	± 2.7 dB
Frequency	± 1 × 10 ⁻⁸
Temperature	± 2 °C
Humidity	± 2 %
Voltage supply DC	± 2 %

This uncertainty represents an expanded uncertainty expressed at approximately the 95 % confidence level using a coverage factor of k=2.

Measurement uncertainty complies with the requirements of the normative documents and is guaranteed by the test procedures and test equipment.

2.6 Photo of test site

Figure 2.6.1

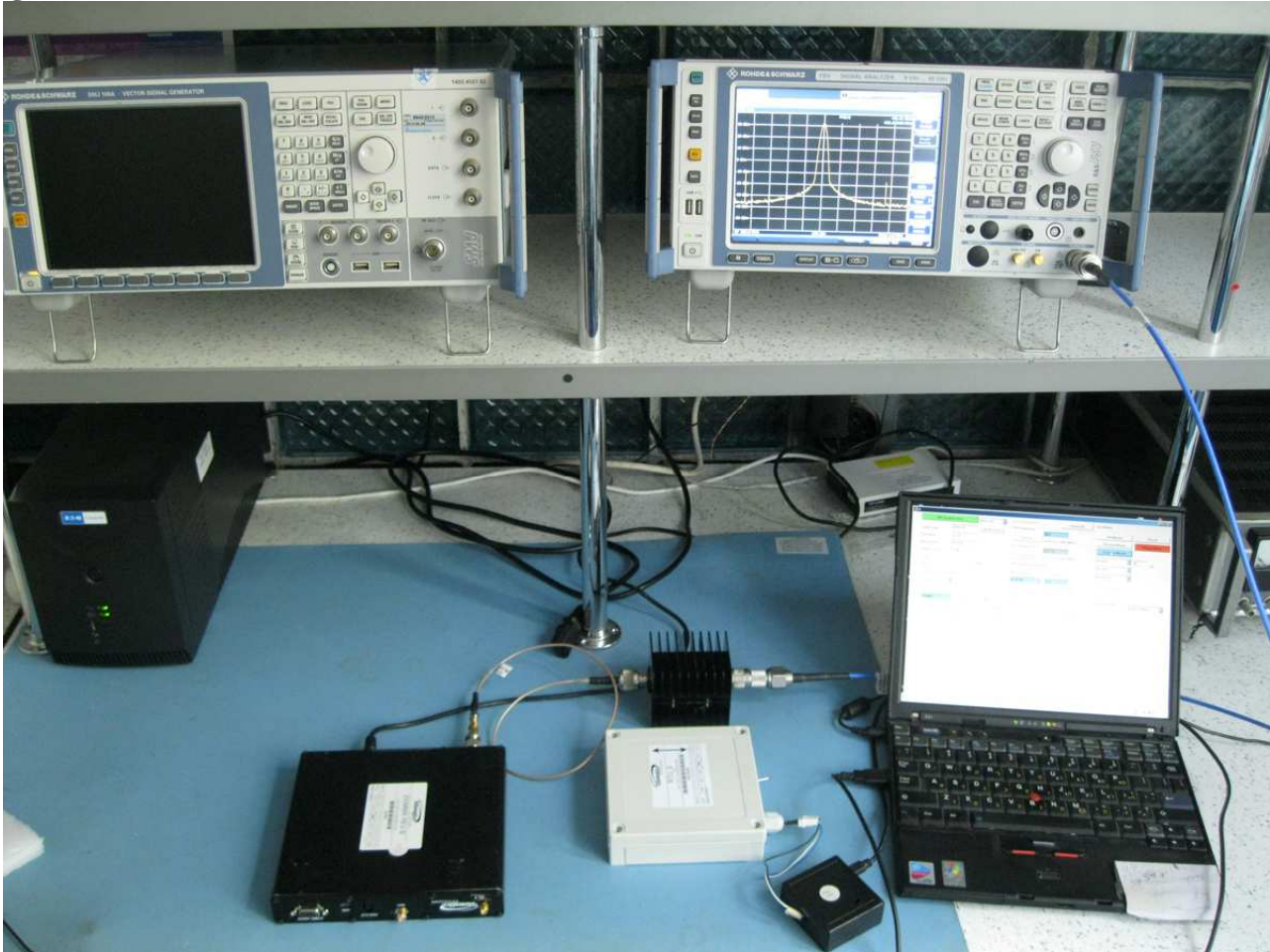

Figure 2.6.2

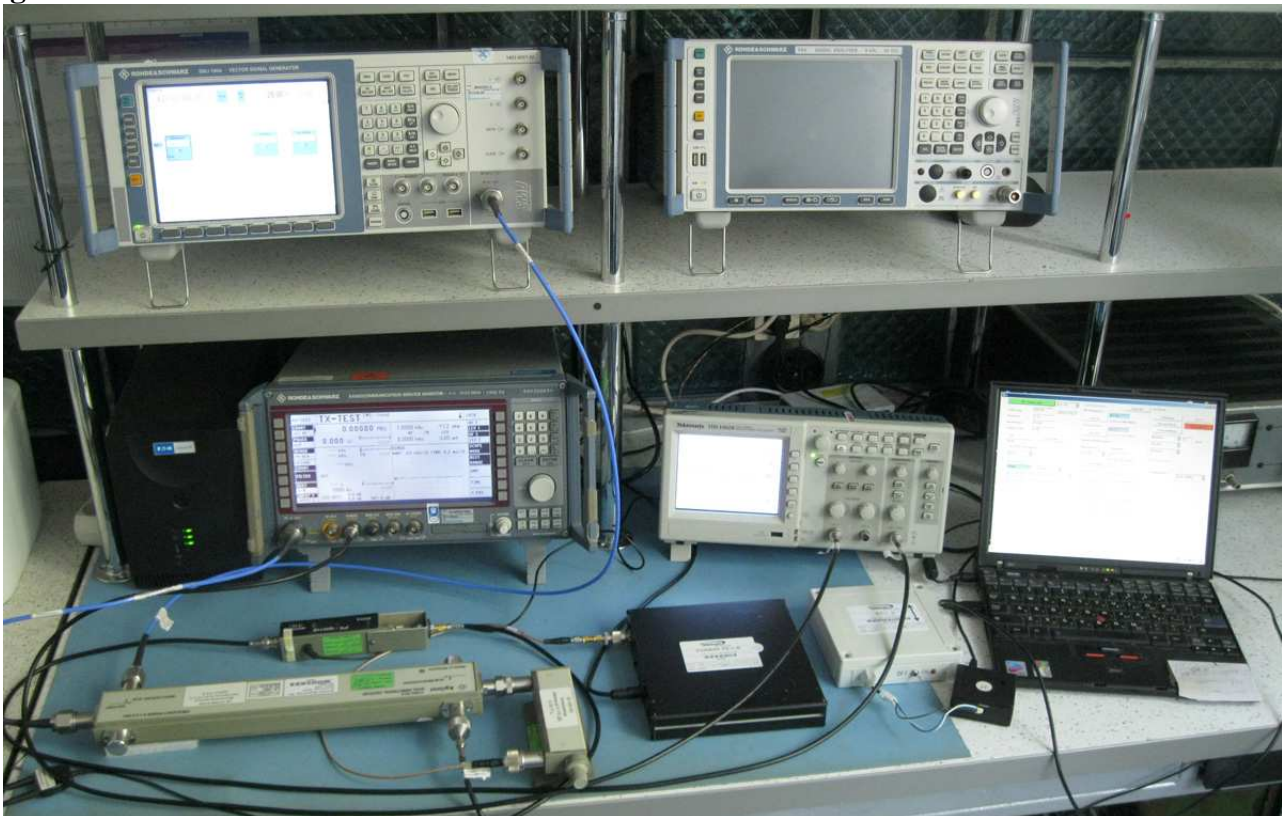

Figure 2.6.3



Figure 2.6.4



3 REPORT OF MEASUREMENTS AND EXAMINATIONS OF THE TRANSMITTER

3.1 Emission mask

3.1.1 Test requirements 90.210(e)

Except as indicated elsewhere in this part, transmitters used in the radio services governed by this part must comply with the emission masks outlined in this section. Unless otherwise stated, per paragraphs (d)(4), (e)(4), and (m) of this section, measurements of emission power can be expressed in either peak or average values provided that emission powers are expressed with the same parameters used to specify the unmodulated transmitter carrier power. For transmitters that do not produce a full power unmodulated carrier, reference to the unmodulated transmitter carrier power refers to the total power contained in the channel bandwidth. Unless indicated elsewhere in this part, the table in this section specifies the emission masks for equipment operating in the frequency bands governed under this part.

Table 3.1.1 Limit Emissions Mask

Frequency band (MHz)	Mask for equipment with Audio low pass filter	Mask for equipment without audio low pass filter
Below 25 ¹	A or B	A or C
25-50	B	C
72-76	B	C
150-174 ²	B, D, or E	C, D, or E
150 Paging-only	B	C
220-222	F	F
421-512 ²	B, D, or E	C, D, or E
450 Paging-only	B	G
806-809/851-854	B	H
809-824/854-869 ³	B	G
896-901/935-940	I	J
902-928	K	K
929-930	B	G
4940-4990 MHz	L or M	L or M.
5850-5925 ⁴		
All other bands	B	C

² Equipment designed to operate with a 25 kHz channel bandwidth must meet the requirements of Emission Mask B or C, as applicable. Equipment designed to operate with a 12.5 kHz channel bandwidth must meet the requirements of Emission Mask D, and equipment designed to operate with a 6.25 kHz channel bandwidth must meet the requirements of Emission Mask E.

(e) Emission Mask E—6.25 kHz or less channel bandwidth equipment. For transmitters designed to operate with a 6.25 kHz or less bandwidth, any emission must be attenuated below the power (P) of the highest emission contained within the authorized bandwidth as follows:

- (1) On any frequency from the center of the authorized bandwidth f_0 to 3.0 kHz removed from f_0 : Zero dB.
- (2) On any frequency removed from the center of the authorized bandwidth by a displacement frequency (f_d in kHz) of more than 3.0 kHz but no more than 4.6 kHz: At least $30 + 16.67(f_d - 3 \text{ kHz})$ or $55 + 10 \log (P)$ or 65 dB, whichever is the lesser attenuation.
- (3) On any frequency removed from the center of the authorized bandwidth by more than 4.6 kHz: At least $55 + 10 \log (P)$ or 65 dB, whichever is the lesser attenuation.

(4) The reference level for showing compliance with the emission mask shall be established using a resolution bandwidth sufficiently wide (usually two to three times the channel bandwidth) to capture the true peak emission of the equipment under test. In order to show compliance with the emissions mask up to and including 50 kHz removed from the edge of the authorized bandwidth, adjust the resolution bandwidth to 100 Hz with the measuring instrument in a peak hold mode. A sufficient number of sweeps must be measured to insure that the emission profile is developed. If video filtering is used, its bandwidth must not be less than the instrument resolution bandwidth. For emissions beyond 50 kHz from the edge of the authorized bandwidth, see paragraph (m) of this section. If it can be shown that use of the above instrumentation settings do not accurately represent the true interference potential of the equipment under test, then an alternate procedure may be used provided prior Commission approval is obtained.

3.1.2 Test procedure

- 1) The transmitter output was connected to the test load and then to the spectrum analyzer.
- 2) The transmitter was set up to the normal operational mode with maximum output power.
- 3) Spectrum analyzer was set to the measurement mode of Spectrum Emission Mask (SEM) with the following settings:
 - Centre frequency set to the center frequency of the channel
 - The Relative Mask setting was chosen
 - RBW=100 Hz, VBW=300 Hz, Video Detector = Peak, Trace = MAX HOLD.

3.1.3 Test setup layout

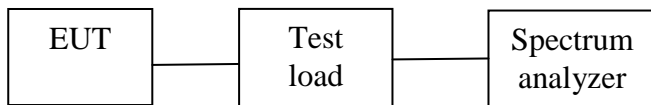

Figure 3.1.1

3.1.4 Test result

Temperature: +23 °C

Relative humidity: 47 %

Plot 3.1.4.1: Emissions Mask test result at low frequency

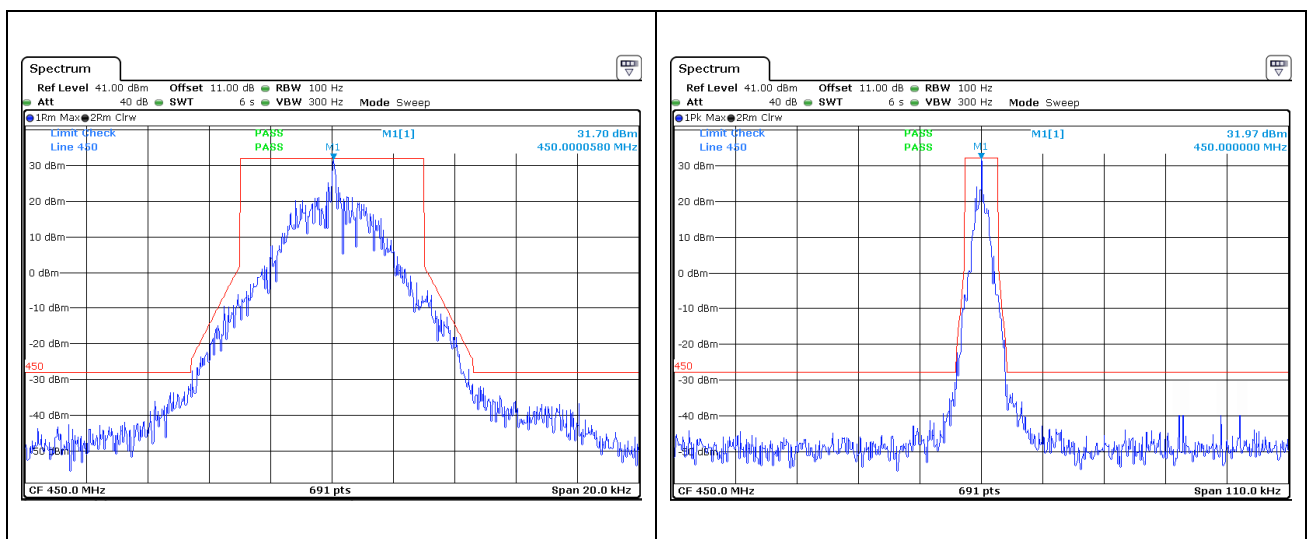

Plot 3.1.4.2: Emissions Mask test result at mid frequency

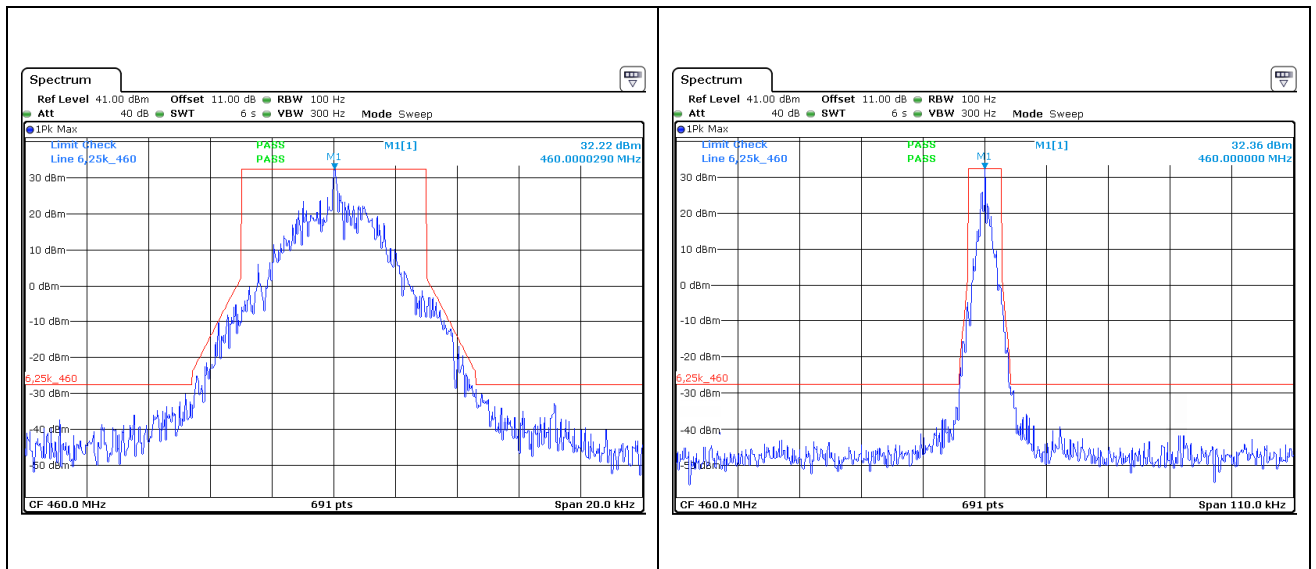

Plot 3.1.4.3: Emissions Mask test result at high frequency

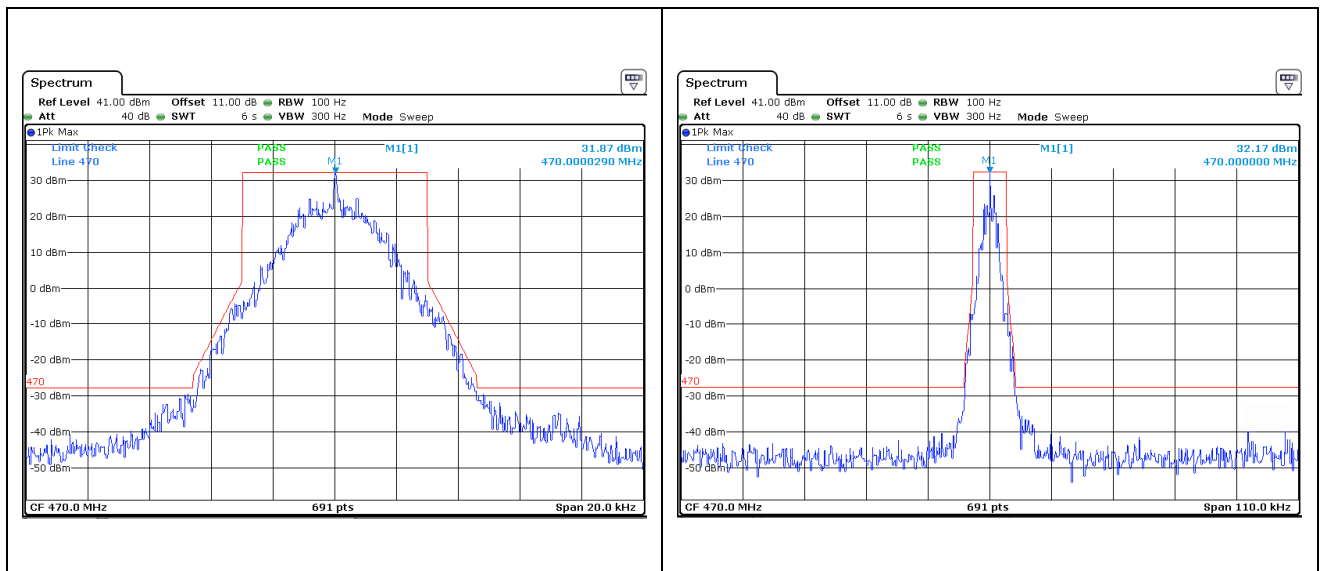

3.2 Conducted Spurious Emissions

3.2.1 Test requirements 90.210 (e)

Except as indicated elsewhere in this part, transmitters used in the radio services governed by this part must comply with the emission masks outlined in this section. Unless otherwise stated, per paragraphs (d)(4), (e)(4), and (m) of this section, measurements of emission power can be expressed in either peak or average values provided that emission powers are expressed with the same parameters used to specify the unmodulated transmitter carrier power. For transmitters that do not produce a full power unmodulated carrier, reference to the unmodulated transmitter carrier power refers to the total power contained in the channel bandwidth. Unless indicated elsewhere in this part, the table in this section specifies the emission masks for equipment operating in the frequency bands governed under this part.

Frequency band (MHz)	Mask for equipment with Audio low pass filter	Mask for equipment without audio low pass filter
Below 25 ¹	A or B	A or C
25-50	B	C
72-76	B	C
150-174 ²	B, D, or E	C, D, or E
150 Paging-only	B	C
220-222	F	F
421-512 ²	B, D, or E	C, D, or E
450 Paging-only	B	G
806-809/851-854	B	H
809-824/854-869 ³	B	G
896-901/935-940	I	J
902-928	K	K
929-930	B	G
4940-4990 MHz	L or M	L or M.
5850-5925 ⁴		
All other bands	B	C

² Equipment designed to operate with a 25 kHz channel bandwidth must meet the requirements of Emission Mask B or C, as applicable. Equipment designed to operate with a 12.5 kHz channel bandwidth must meet the requirements of Emission Mask D, and equipment designed to operate with a 6.25 kHz channel bandwidth must meet the requirements of Emission Mask E.

(e) Emission Mask E—6.25 kHz or less channel bandwidth equipment. For transmitters designed to operate with a 6.25 kHz or less bandwidth, any emission must be attenuated below the power (P) of the highest emission contained within the authorized bandwidth as follows:

(1) On any frequency from the center of the authorized bandwidth f_0 to 3.0 kHz removed from f_0 : Zero dB.

(2) On any frequency removed from the center of the authorized bandwidth by a displacement frequency (f_d in kHz) of more than 3.0 kHz but no more than 4.6 kHz: At least $30 + 16.67(f_d - 3 \text{ kHz})$ or $55 + 10 \log (P)$ or 65 dB, whichever is the lesser attenuation.

(3) On any frequency removed from the center of the authorized bandwidth by more than 4.6 kHz: At least $55 + 10 \log (P)$ or 65 dB, whichever is the lesser attenuation.

(4) The reference level for showing compliance with the emission mask shall be established using a resolution bandwidth sufficiently wide (usually two to three times the channel bandwidth) to capture the true peak emission of the equipment under test. In order to show compliance with the emissions mask up to and including 50 kHz removed from the edge of the authorized bandwidth, adjust the resolution bandwidth to 100 Hz with the measuring instrument in a peak hold mode. A sufficient number of sweeps must be measured to insure that the emission profile is developed. If video filtering is used, its bandwidth must not be less than the instrument resolution bandwidth. For emissions beyond 50 kHz from the edge of the authorized bandwidth, see paragraph (m) of this section. If it can be shown that use of the above instrumentation settings do not accurately represent the true interference potential of the equipment under test, then an alternate procedure may be used provided prior Commission approval is obtained.

3.2.2 Test procedure

The procedure used was ANSI/TIA-603-D:2010. Substitution RF signal generator was used.

- 1) The transmitter was connected to the spectrum analyzer using the test load.
- 2) The transmitter was set up to the normal operational mode with maximum output power rating.
- 3) The spurious emissions were observed in the band of +50 kHz from the edge of the authorized bandwidth to frequency equal 10 times the carrier frequency.

The spectrum analyzer was adjusted for the following settings:

Resolution Bandwidth = 10 kHz for spurious emission below 1 GHz, and 1 MHz for spurious emission above 1 GHz.

Video Bandwidth ≥ 3 times the resolution bandwidth.

Sweep Speed ≤ 2000 Hz per second.

Detector Mode = average power.

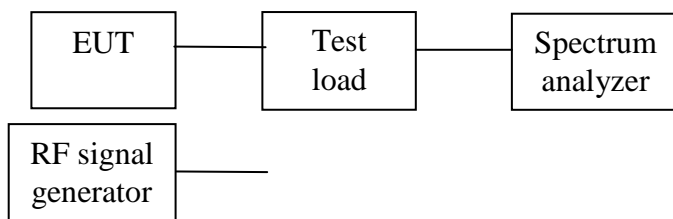
3.2.3 Test setup layout**3.2.4 Test result**

Temperature: +23 °C

Relative humidity: 47 %

Table 3.2.1

Frequency, MHz	Output Power (dB)	Gen. Output (dBm)	Difference, dBc	Limit, dBc	Result (Pass, Fail, N/A)
450	35.24	-	-	-	-
450.0448	- 32.32	- 32.04	- 67.28	- 60	Pass
450.1955	- 34.33	- 34.12	- 69.36	- 60	Pass
450.2476	- 36.69	- 36.42	- 71.03	- 60	Pass
460	35.03	-	-	-	-
460.0517	- 31.64	- 31.46	- 66.49	- 60	Pass
460.1584	- 32.55	- 32.34	- 67.37	- 60	Pass
460.2384	- 35.74	- 35.56	- 70.59	- 60	Pass
470	35.01	-	-	-	-
470.0529	- 31.77	- 31.60	- 66.61	- 60	Pass
470.1549	- 32.51	- 32.34	- 67.35	- 60	Pass
470.2036	- 34.29	- 34.08	- 69.09	- 60	Pass

Plot 3.2.1: Output Power (Frequency 450 MHz)

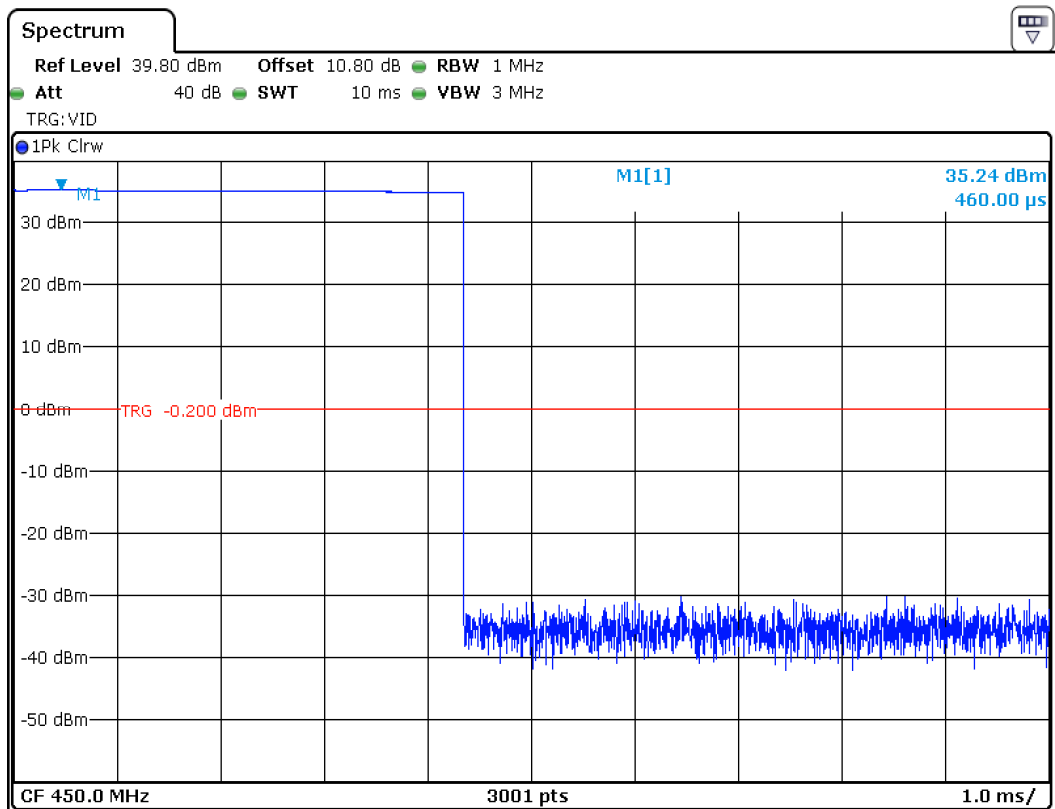

Table 3.2.2 Conducted Spurious Emissions (Frequency 450 MHz)

Frequency, MHz	Output Power, dBm	Gen. Output, dBm	Difference, dBc	Limit, dBc	Result (Pass, Fail, N/A)
450	35.24	-	-	-	-
900	- 39.64	- 39.38	- 74.62	- 60	Pass
1350	- 42.95	- 39.07	- 74.31	- 60	Pass
1800	- 62.22	- 59.36	- 94.60	- 60	Pass
2250	- 60.88	- 57.98	- 93.22	- 60	Pass
2700	- 63.93	- 60.96	- 96.20	- 60	Pass
3150	-	-	-	- 60	Pass
3600	-	-	-	- 60	Pass
4050	-	-	-	- 60	Pass
4500	-	-	-	- 60	Pass

Plot 3.2.2: Output Power (Frequency 460 MHz)

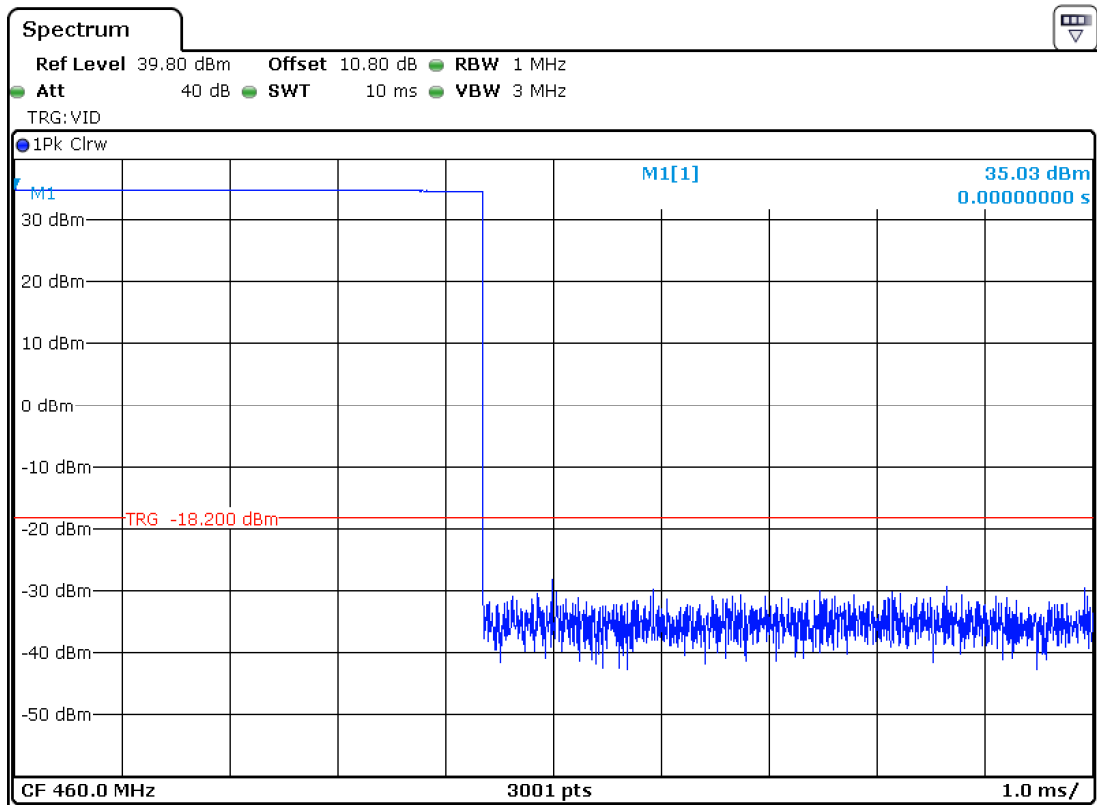

Table 3.2.3 Conducted Spurious Emissions (Frequency 460 MHz)

Frequency, MHz	Output Power, dBm	Gen. Output, dBm	Difference, dBc	Limit, dBc	Result (Pass, Fail, N/A)
460	35.03	-	-	-	-
920	- 38.69	- 38.45	- 73.48	- 60	Pass
1380	- 41.66	- 39.78	- 74.81	- 60	Pass
1840	- 61.70	- 58.84	- 93.87	- 60	Pass
2300	- 59.26	- 56.37	- 91.40	- 60	Pass
2760	- 62.54	- 59.63	- 94.66	- 60	Pass
3220	-	-	-	- 60	Pass
3680	- 61.84	- 58.86	- 93.89	- 60	Pass
4140	-	-	-	- 60	Pass
4600	-	-	-	- 60	Pass

Plot 3.2.3: Output Power (Frequency 460 MHz)

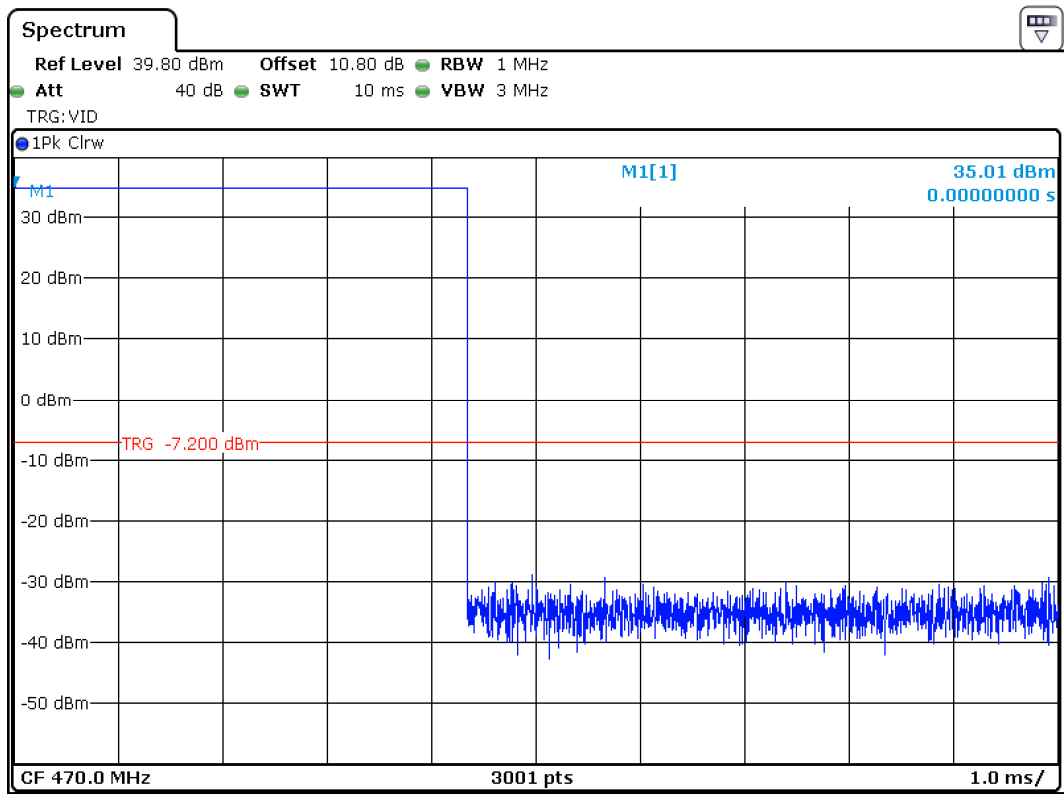

Table 3.2.4 Conducted Spurious Emissions (Frequency 470 MHz)

Frequency, MHz	Output Power, dBm	Gen. Output, dBm	Difference, dBc	Limit, dBc	Result (Pass, Fail, N/A)
470	35.01	-	-	-	-
940	- 38.50	- 38.27	- 73.28	- 60	Pass
1410	- 41.47	- 39.54	- 74.55	- 60	Pass
1880	- 62.70	- 59.86	- 94.87	- 60	Pass
2350	- 55.41	- 52.55	- 87.56	- 60	Pass
2820	- 61.80	- 58.93	- 93.94	- 60	Pass
3290	-	-	-	- 60	Pass
3760	-	-	-	- 60	Pass
4230	-	-	-	- 60	Pass
4700	-	-	-	- 60	Pass

3.3 Radiated Spurious Emissions

3.3.1 Test requirements 90.210 (e)

Except as indicated elsewhere in this part, transmitters used in the radio services governed by this part must comply with the emission masks outlined in this section. Unless otherwise stated, per paragraphs (d)(4), (e)(4), and (m) of this section, measurements of emission power can be expressed in either peak or average values provided that emission powers are expressed with the same parameters used to specify the unmodulated transmitter carrier power. For transmitters that do not produce a full power unmodulated carrier, reference to the unmodulated transmitter carrier power refers to the total power contained in the channel bandwidth. Unless indicated elsewhere in this part, the table in this section specifies the emission masks for equipment operating in the frequency bands governed under this part.

Frequency band (MHz)	Mask for equipment with Audio low pass filter	Mask for equipment without audio low pass filter
Below 25 ¹	A or B	A or C
25-50	B	C
72-76	B	C
150-174 ²	B, D, or E	C, D, or E
150 Paging-only	B	C
220-222	F	F
421-512 ²	B, D, or E	C, D, or E
450 Paging-only	B	G
806-809/851-854	B	H
809-824/854-869 ³	B	G
896-901/935-940	I	J
902-928	K	K
929-930	B	G
4940-4990 MHz	L or M	L or M.
5850-5925 ⁴		
All other bands	B	C

² Equipment designed to operate with a 25 kHz channel bandwidth must meet the requirements of Emission Mask B or C, as applicable. Equipment designed to operate with a 12.5 kHz channel bandwidth must meet the requirements of Emission Mask D, and equipment designed to operate with a 6.25 kHz channel bandwidth must meet the requirements of Emission Mask E.

(e) Emission Mask E—6.25 kHz or less channel bandwidth equipment. For transmitters designed to operate with a 6.25 kHz or less bandwidth, any emission must be attenuated below the power (P) of the highest emission contained within the authorized bandwidth as follows:

(1) On any frequency from the center of the authorized bandwidth f_0 to 3.0 kHz removed from f_0 : Zero dB.

(2) On any frequency removed from the center of the authorized bandwidth by a displacement frequency (f_d in kHz) of more than 3.0 kHz but no more than 4.6 kHz: At least $30 + 16.67(f_d - 3 \text{ kHz})$ or $55 + 10 \log (P)$ or 65 dB, whichever is the lesser attenuation.

(3) On any frequency removed from the center of the authorized bandwidth by more than 4.6 kHz: At least $55 + 10 \log (P)$ or 65 dB, whichever is the lesser attenuation.

(4) The reference level for showing compliance with the emission mask shall be established using a resolution bandwidth sufficiently wide (usually two to three times the channel bandwidth) to capture the true peak emission of the equipment under test. In order to show compliance with the emissions mask up to and including 50 kHz removed from the edge of the authorized bandwidth, adjust the resolution bandwidth to 100 Hz with the measuring instrument in a peak hold mode. A sufficient number of sweeps must be measured to insure that the emission profile is developed. If video filtering

is used, its bandwidth must not be less than the instrument resolution bandwidth. For emissions beyond 50 kHz from the edge of the authorized bandwidth, see paragraph (m) of this section. If it can be shown that use of the above instrumentation settings do not accurately represent the true interference potential of the equipment under test, then an alternate procedure may be used provided prior Commission approval is obtained.

3.3.2 Test procedure

The procedure used was ANSI/TIA-603-D:2010. Substitution antenna with RF signal generator was used.

The transmitter was set up to the normal operational mode with maximum output power and connected to standard transmitter load.

- 1) The spurious emissions were observed in the band of +50 kHz from the edge of the authorized bandwidth to frequency equal 10 times the carrier frequency.
- 2) The transmitter to be tested was placed on the turntable in the test site compliant with ANSI C63.4-2001 clause 5.4.
- 3) Measurement antenna was placed at the distance of 3m away from the EUT with vertical polarization.
- 4) The spurious emissions were observed in the band of +50 kHz from the edge of the authorized bandwidth to the tenth harmonic of the carrier.

The spectrum analyzer was adjusted for the following settings:

Resolution Bandwidth = 10 kHz for spurious emission below 1 GHz, and 1 MHz for spurious emission above 1 GHz.

Video Bandwidth = 300 kHz for spurious emission below 1 GHz, and 3 MHz for spurious emission above 1 GHz.

Sweep Speed slow enough to maintain measurement calibration.

Detector Mode = Positive Peak.

- 5) The height of measurement antenna was changed from 1m to 4m in 10 cm steps to obtain maximum result on the spectrum analyzer.
- 6) The turntable was rotated around its axis to obtain maximum result on the spectrum analyzer.
- 7) Highest possible readings of the spectrum analyzer were recorded.
- 8) Measurements were repeated for horizontal polarization of measurement antenna.
- 9) The transmitter was replaced with a substitution antenna connected to RF signal generator.
- 10) The power into a reference ideal half-wave dipole antenna is calculated by reducing the reading from RF signal generator by the power loss in the cable between the generator and the substitution antenna, and further corrected for the gain of the substitution antenna used relative to an ideal half-wave dipole antenna:

$$P_d \text{ (dBm)} = P_g \text{ (dBm)} - \text{cable loss (dB)} + \text{antenna gain (dB)},$$

where:

P_d is the dipole equivalent power,

P_g is the generator output power into the substitution antenna.

- 11) Radiated spurious emissions (dB) = TX power (dBm) - P_d (dBm).

3.3.3 Test setup layout

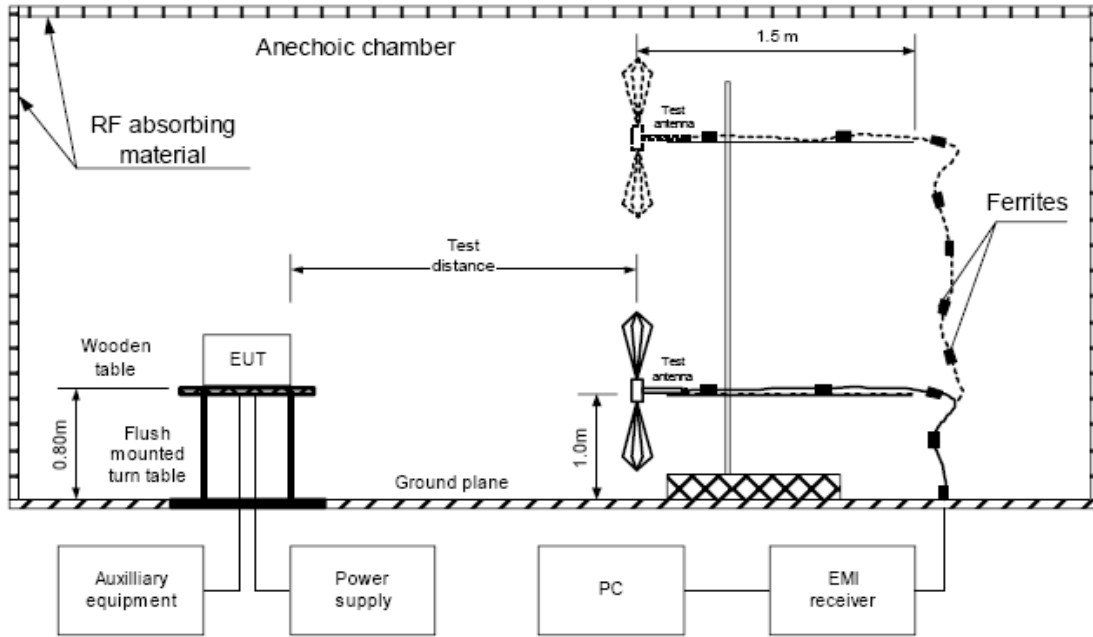

3.3.4 Test result

Temperature: +20 °C

Relative humidity: 68 %

Table 3.3.1 Radiated Spurious Emissions (Frequency 470 MHz, vertical polarization):

F, MHz	Gen. Output, dBm	Coax Loss, dB	Ant. Gain, dBi	Ant. Gain, dBd	Dipole Eq. Power, dBm	Difference, dBc	Limit, dBc	Test result (Pass, Fail, N/A)
470					34,99			
940	- 38,65	2,3	- 7,29	- 9,44	- 50,39	- 85,38	- 60	Pass
1410	- 42,87	3,3	4,80	2,65	- 43,52	- 78,51	- 60	Pass
1880	- 54,43	4,4	5,00	2,85	- 55,98	- 90,97	- 60	Pass
2350	- 58,61	4,6	5,50	3,35	- 59,86	- 94,85	- 60	Pass
2820	- 59,37	5,8	6,50	4,35	- 60,82	- 95,81	- 60	Pass
3290	- 61,32	6,5	7,20	5,05	- 62,77	- 97,76	- 60	Pass
3760	- 62,51	6,2	7,66	5,51	- 63,20	- 98,19	- 60	Pass
4230	- 62,87	6,6	7,62	5,47	- 64,00	- 98,99	- 60	Pass
4700	- 64,12	7,1	7,70	5,55	- 65,67	-100,66	- 60	Pass

Table 3.3.2 Radiated Spurious Emissions (Frequency 460 MHz, vertical polarization):

F, MHz	Gen. Output, dBm	Coax Loss, dB	Ant. Gain, dBi	Ant. Gain, dBd	Dipole Eq. Power, dBm	Difference, dBc	Limit, dBc	Test result (Pass, Fail, N/A)
460					35,02			
920	- 35,28	2,4	- 7,12	- 9,27	- 46,95	- 81,97	- 60	Pass
1380	- 41,62	3,3	4,60	2,45	- 42,47	- 77,49	- 60	Pass
1840	- 54,23	4,1	5,00	2,85	- 55,48	- 90,50	- 60	Pass
2300	- 58,45	5,0	5,40	3,25	- 60,20	- 95,22	- 60	Pass
2760	- 59,42	5,7	6,40	4,25	- 60,87	- 95,89	- 60	Pass
3220	- 59,64	6,4	7,12	4,97	- 61,07	- 96,09	- 60	Pass
3680	-60,13	6,3	7,60	5,45	- 60,98	- 96,00	- 60	Pass
4140	- 62,56	6,5	7,70	5,55	- 63,51	- 98,53	- 60	Pass
4600	- 62,57	7,1	7,50	5,35	- 64,32	- 99,34	- 60	Pass

Table 3.3.3 Radiated Spurious Emissions (Frequency 450 MHz, vertical polarization):

F, MHz	Gen. Output, dBm	Coax Loss, dB	Ant. Gain, dBi	Ant. Gain, dBd	Dipole Eq. Power, dBm	Difference, dBc	Limit, dBc	Test result (Pass, Fail, N/A)
450					35,22			
900	- 35,32	2,5	- 6,90	- 9,05	- 46,87	- 82,09	- 60	Pass
1350	- 40,43	3,6	4,50	2,35	- 41,68	- 76,90	- 60	Pass
1800	- 52,19	4,1	5,50	3,35	- 52,94	- 88,16	- 60	Pass
2250	- 56,74	5,2	5,40	3,25	- 58,69	- 93,91	- 60	Pass
2700	- 58,96	5,3	6,24	4,09	- 60,17	- 95,39	- 60	Pass
3150	- 59,18	6,6	7,10	4,95	- 60,83	- 96,05	- 60	Pass
3600	- 60,69	6,2	7,50	5,35	- 61,54	- 96,76	- 60	Pass
4050	- 62,56	6,4	7,90	5,75	- 63,21	- 98,43	- 60	Pass
4500	- 62,46	7,1	7,30	5,15	- 64,41	- 99,63	- 60	Pass

Table 3.3.4 Radiated Spurious Emissions (Frequency 470 MHz, horizontal polarization):

F, MHz	Gen. Output, dBm	Coax Loss, dB	Ant. Gain, dBi	Ant. Gain, dBd	Dipole Eq. Power, dBm	Difference, dBc	Limit, dBc	Test result (Pass, Fail, N/A)
470					33,95			
940	- 37,43	2,3	- 7,29	- 9,44	- 49,17	- 81,92	- 60	Pass
1410	- 43,75	3,3	4,80	2,65	- 44,40	- 92,22	- 60	Pass
1880	- 54,15	4,4	5,00	2,85	- 55,70	- 93,17	- 60	Pass
2350	- 59,64	4,6	5,50	3,35	- 60,89	- 89,41	- 60	Pass
2820	- 59,48	5,8	6,50	4,35	- 60,93	- 89,82	- 60	Pass
3290	- 62,32	6,5	7,20	5,05	- 63,77	- 89,10	- 60	Pass
3760	- 63,35	6,2	7,66	5,51	- 64,04	- 91,77	- 60	Pass
4230	- 64,02	6,6	7,62	5,47	- 65,15	- 88,40	- 60	Pass
4700	- 65,87	7,1	7,70	5,55	- 67,42	- 90,31	- 60	Pass

Table 3.3.5 Radiated Spurious Emissions (Frequency 460 MHz, horizontal polarization):

F, MHz	Gen. Output, dBm	Coax Loss, dB	Ant. Gain, dBi	Ant. Gain, dBd	Dipole Eq. Power, dBm	Difference, dBc	Limit, dBc	Test result (Pass, Fail, N/A)
460					34,14			
920	- 37,14	2,4	- 7,12	- 9,27	- 48,81	- 82,95	- 60	Pass
1380	- 42,24	3,3	4,60	2,45	- 43,09	- 77,23	- 60	Pass
1840	- 56,11	4,1	5,00	2,85	- 57,36	- 91,50	- 60	Pass
2300	- 60,67	5,0	5,40	3,25	- 62,42	- 96,56	- 60	Pass
2760	- 61,49	5,7	6,40	4,25	- 62,94	- 97,08	- 60	Pass
3220	- 62,84	6,4	7,12	4,97	- 64,27	- 98,41	- 60	Pass
3680	- 63,48	6,3	7,60	5,45	- 64,33	- 98,47	- 60	Pass
4140	- 63,59	6,5	7,70	5,55	- 64,54	- 98,68	- 60	Pass
4600	- 63,80	7,1	7,50	5,35	- 65,55	- 99,69	- 60	Pass

Table 3.3.6 Radiated Spurious Emissions (Frequency 450 MHz, horizontal polarization):

F, MHz	Gen. Output, dBm	Coax Loss, dB	Ant. Gain, dBi	Ant. Gain, dBd	Dipole Eq. Power, dBm	Difference, dBc	Limit, dBc	Test result (Pass, Fail, N/A)
450					34,19			
900	- 37,68	2,5	- 6,90	- 9,05	- 49,23	- 83,42	- 60	Pass
1350	- 42,49	3,6	4,50	2,35	- 43,74	- 77,93	- 60	Pass
1800	- 57,32	4,1	5,50	3,35	- 58,07	- 92,26	- 60	Pass
2250	- 56,91	5,2	5,40	3,25	- 58,86	- 93,05	- 60	Pass
2700	- 59,68	5,3	6,24	4,09	- 60,89	- 95,08	- 60	Pass
3150	- 62,53	6,6	7,10	4,95	- 64,18	- 98,37	- 60	Pass
3600	- 62,65	6,2	7,50	5,35	- 63,50	- 97,69	- 60	Pass
4050	- 62,89	6,4	7,90	5,75	- 63,54	- 97,73	- 60	Pass
4500	- 63,57	7,1	7,30	5,15	- 65,52	- 99,71	- 60	Pass

3.4 Transient stability

3.4.1 Test requirements 90.214

Transmitters designed to operate in the 150-174 MHz and 421-512 MHz frequency bands must maintain transient frequencies within the maximum frequency difference limits during the time intervals indicated:

Table 3.4.1 Limit Transient Frequency Behavior

Time intervals ^{1,2}	Maximum frequency difference ³	All equipment	
		150 to 174 MHz	421 to 512 MHz
Transient Frequency Behavior for Equipment Designed to Operate on 25 kHz Channels			
t ₁ ⁴	±25.0 kHz	5.0 ms	10.0 ms
t ₂	±12.5 kHz	20.0 ms	25.0 ms
t ₃ ⁴	±25.0 kHz	5.0 ms	10.0 ms
Transient Frequency Behavior for Equipment Designed to Operate on 12.5 kHz Channels			
t ₁ ⁴	±12.5 kHz	5.0 ms	10.0 ms
t ₂	±6.25 kHz	20.0 ms	25.0 ms
t ₃ ⁴	±12.5 kHz	5.0 ms	10.0 ms
Transient Frequency Behavior for Equipment Designed to Operate on 6.25 kHz Channels			
t ₁ ⁴	±6.25 kHz	5.0 ms	10.0 ms
t ₂	±3.125 kHz	20.0 ms	25.0 ms
t ₃ ⁴	±6.25 kHz	5.0 ms	10.0 ms

¹ t_{on} is the instant when a 1 kHz test signal is completely suppressed, including any capture time due to phasing.

- t₁ is the time period immediately following t_{on}.
- t₂ is the time period immediately following t₁.
- t₃ is the time period from the instant when the transmitter is turned off until t_{off}.
- t_{off} is the instant when the 1 kHz test signal starts to rise.

² During the time from the end of t₂ to the beginning of t₃, the frequency difference must not exceed the limits specified in § 90.213.

³ Difference between the actual transmitter frequency and the assigned transmitter frequency.

⁴ If the transmitter carrier output power rating is 6 watts or less, the frequency difference during this time period may exceed the maximum frequency difference for this time period.

3.4.2 Test procedure

- 1) The transmitter was connected to the universal radio tester CMS54.
- 2) The transmitter was set up to the normal operational mode at mid frequency with maximum output power.
- 3) The transient behavior of transmitter was observed in the moment of keying (TX-off to TX-on) and unkeying (TX-on to TX-off) using the special option of the CMS54 radio tester.

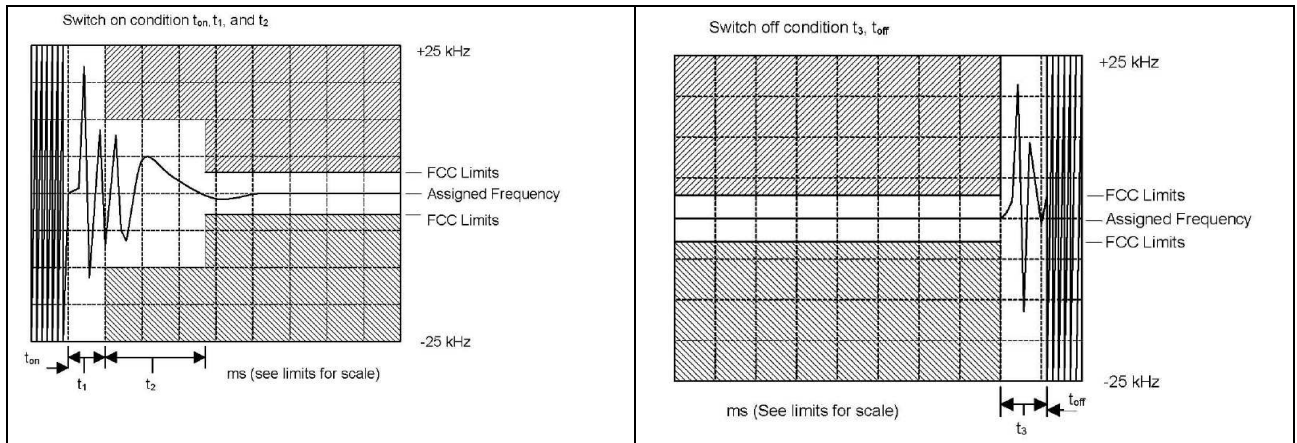

3.4.3 Test setup layout

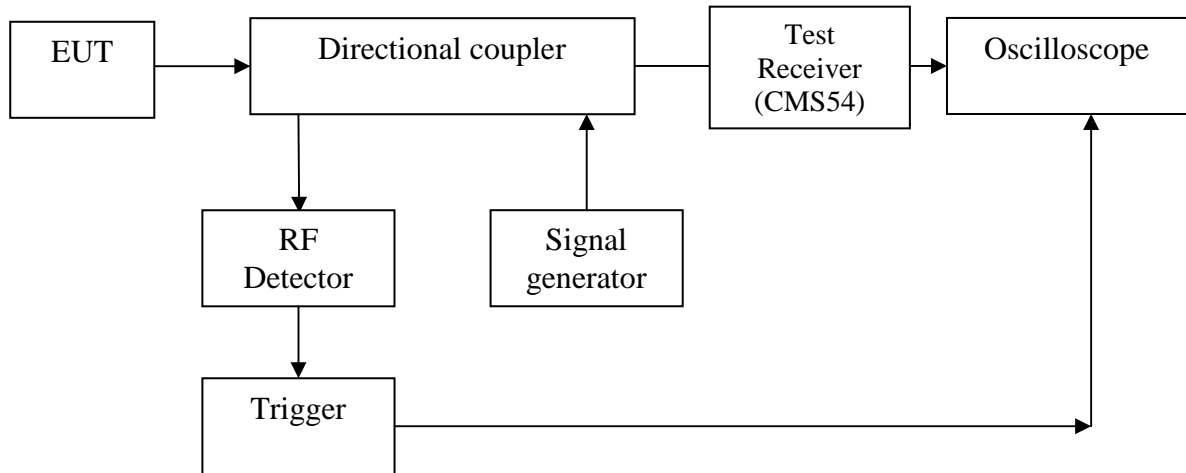

3.4.4 Test result

Temperature: +23 °C

Relative humidity: 47 %

Plot 3.4.1

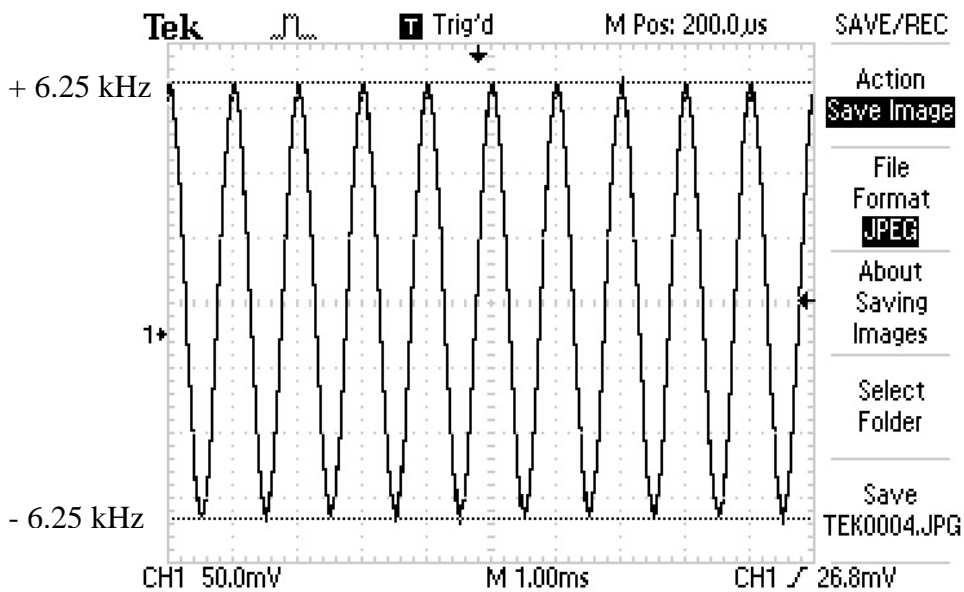

- $\pm 6.25 \text{ kHz} = 338 \text{ mV}$
- $\pm 3.125 \text{ kHz} = 169 \text{ mV}$
- $\pm 230 \text{ Hz } (\pm 0.5 \text{ ppm}) = 12,4 \text{ mV}$

Plot 3.4.2: t_1 time period

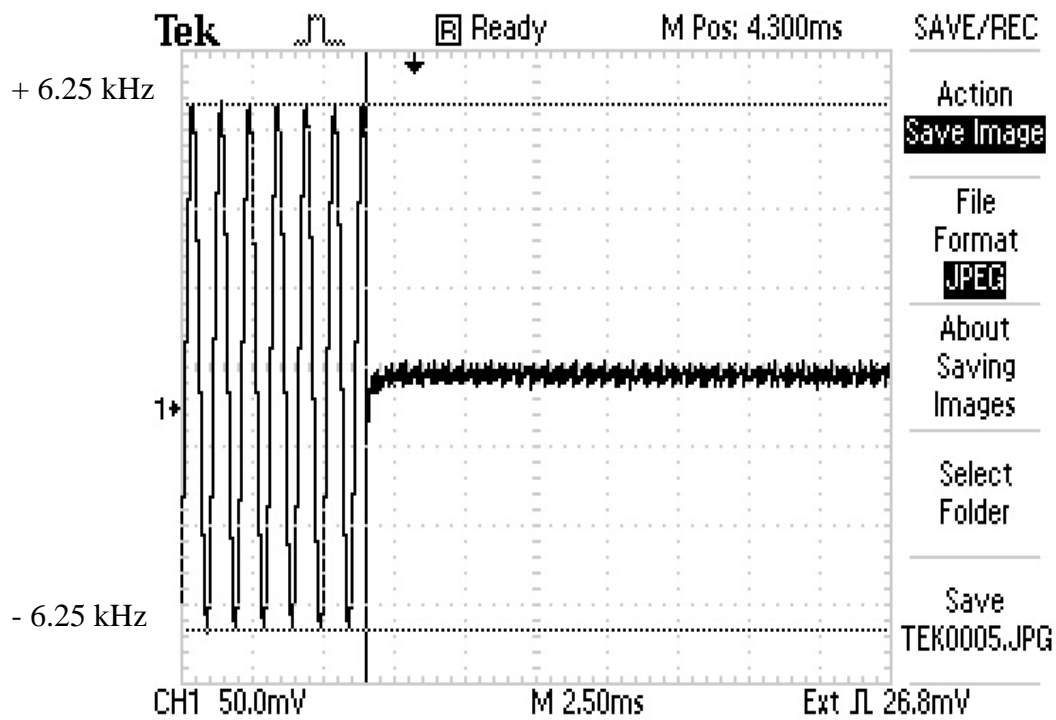

Plot 3.4.3: t_2 time period

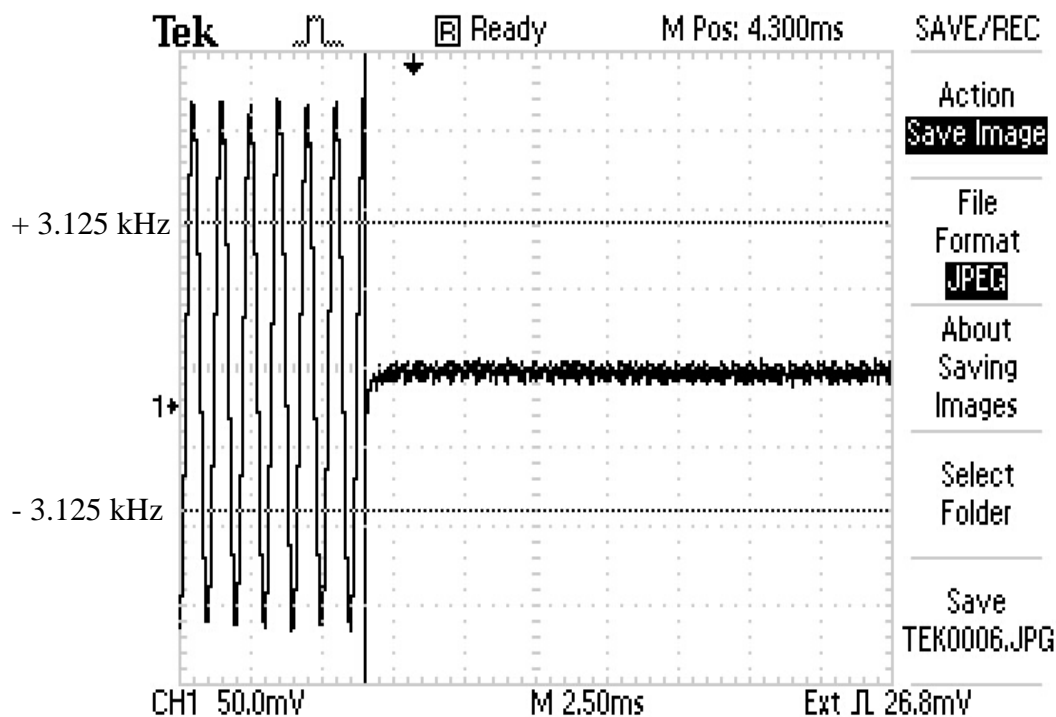

Plot 3.4.4: $t_2 - t_3$ time period

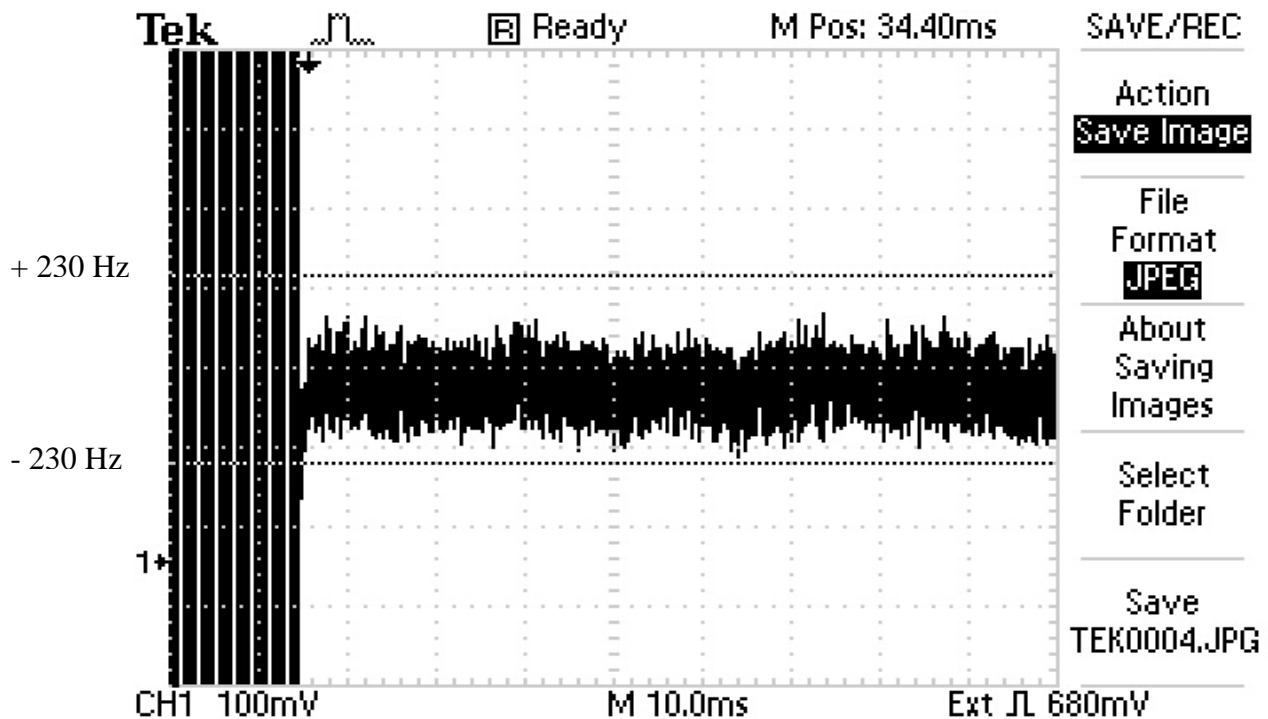

Plot 3.4.5: t_3 time period

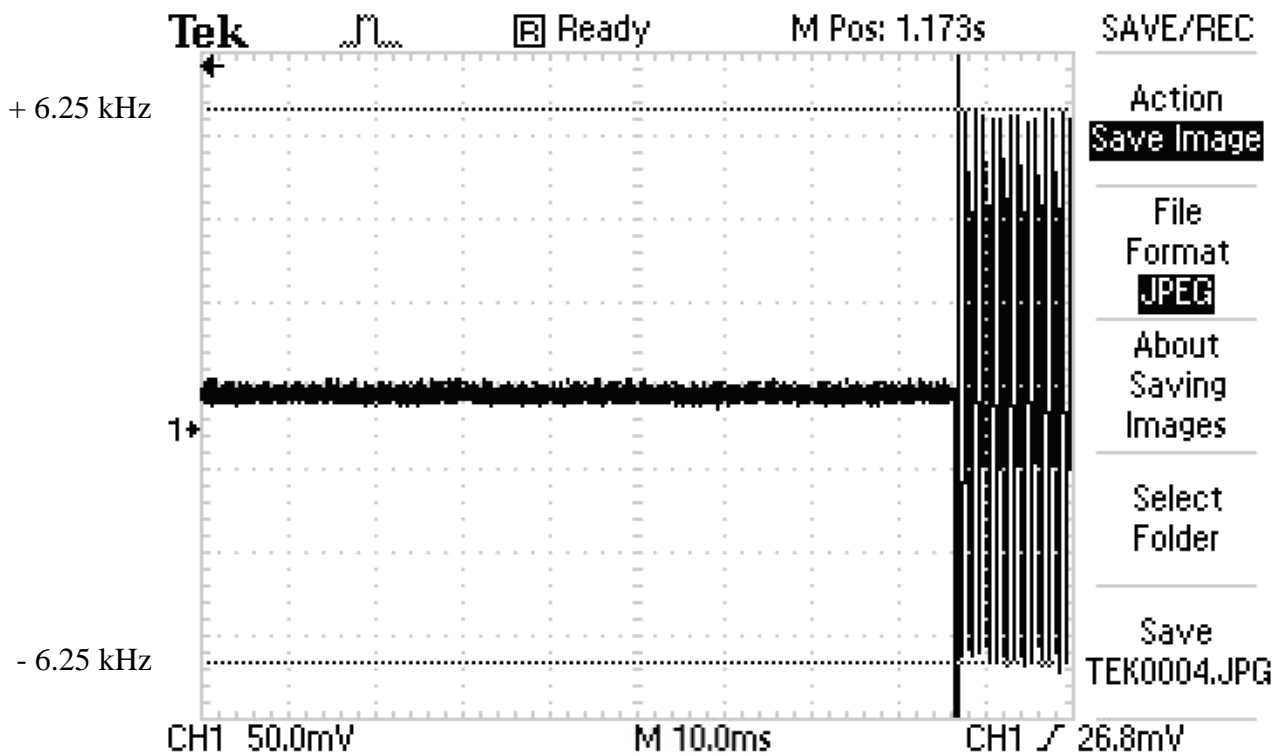

3.5 Frequency stability vs power supply

3.5.1 Test requirements 90.213

(a) Unless noted elsewhere, transmitters used in the services governed by this part must have minimum frequency stability as specified in the following table.

Table 3.5.1 Limit frequency stability vs power supply

Frequency range (MHz)	Fixed and base stations	Mobile stations	
		Over 2 watts output power	2 watts or less output power
Below 25	^{1,2,3} 100	100	200
25-50	20	20	50
72-76	5		50
150-174	^{5,11} 5	⁶ 5	^{4,6} 50
216-220	1.0		1.0
220-222 ¹²	0.1	1.5	1.5
421-512	^{7,11,14} 2.5	⁸ 5	⁸ 5
806-809	¹⁴ 1.0	1.5	1.5
809-824	¹⁴ 1.5	2.5	2.5
851-854	1.0	1.5	1.5
854-869	1.5	2.5	2.5
896-901	¹⁴ 0.1	1.5	1.5
902-928	2.5	2.5	2.5
902-928 ¹³	2.5	2.5	2.5
929-930	1.5		
935-940	0.1	1.5	1.5
1427-1435	⁹ 300	300	300
Above 2450 ¹⁰			

⁷ In the 421-512 MHz band, fixed and base stations with a 12.5 kHz channel bandwidth must have a frequency stability of 1.5 ppm. Fixed and base stations with a 6.25 kHz channel bandwidth must have a frequency stability of 0.5 ppm.

⁸ In the 421-512 MHz band, mobile stations designed to operate with a 12.5 kHz channel bandwidth must have a frequency stability of 2.5 ppm. Mobile stations designed to operate with a 6.25 kHz channel bandwidth must have a frequency stability of 1.0 ppm.

b) For the purpose of determining the frequency stability limits, the power of a transmitter is considered to be the maximum rated output power as specified by the manufacturer.

3.5.2 Test procedure

- 1) The transmitter was set up to the normal operational mode with maximum output power with no modulation signal applied.
- 2) The transmitter was connected to the frequency meter HM8123 for measuring the frequency.
- 3) The supply voltage was changed to observe the frequency stability across the power supply voltage range.

3.5.3 Test setup layout

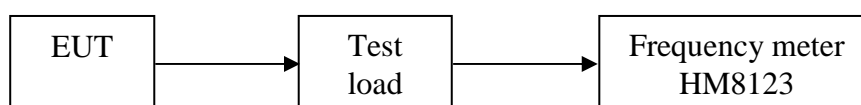

3.5.4 Test result

Temperature: +23 °C

Relative humidity: 47 %

Table 3.5.2

Power Supply voltage, V	Frequency (MHz)	Deviation (Hz)	Deviation (ppm)	Limit, ppm	Result (Pass, Fail, N/A)
13.8	460.000029	+29	+0.063	0.5	Pass
13.4	460.000029	+29	+0.063	0.5	Pass
13.0	460.000029	+29	+0.063	0.5	Pass
12.6	460.000029	+29	+0.063	0.5	Pass
12.2	460.000029	+29	+0.063	0.5	Pass
12.0	460.000029	+29	+0.063	0.5	Pass
11.8	460.000029	+29	+0.063	0.5	Pass
11.4	460.000029	+29	+0.063	0.5	Pass
11.0	460.000029	+29	+0.063	0.5	Pass
10.6	460.000029	+29	+0.063	0.5	Pass
10.2	460.000029	+29	+0.063	0.5	Pass

Reference frequency = 460.0 MHz

3.6 Frequency stability vs temperature

3.6.1 Test requirements 90.213

(a) Unless noted elsewhere, transmitters used in the services governed by this part must have a minimum frequency stability as specified in the following table.

Frequency range (MHz)	Fixed and base stations	Mobile stations	
		Over 2 watts output power	2 watts or less output power
Below 25	1,2,3 100	100	200
25-50	20	20	50
72-76	5		50
150-174	5,11 5	6 5	4,6 50
216-220	1.0		1.0
220-222 ¹²	0.1	1.5	1.5
421-512	7,11,14 2.5	8 5	8 5
806-809	14 1.0	1.5	1.5
809-824	14 1.5	2.5	2.5
851-854	1.0	1.5	1.5
854-869	1.5	2.5	2.5
896-901	14 0.1	1.5	1.5
902-928	2.5	2.5	2.5
902-928 ¹³	2.5	2.5	2.5
929-930	1.5		
935-940	0.1	1.5	1.5
1427-1435	9 300	300	300
Above 2450 ¹⁰			

⁷ In the 421-512 MHz band, fixed and base stations with a 12.5 kHz channel bandwidth must have a frequency stability of 1.5 ppm. Fixed and base stations with a 6.25 kHz channel bandwidth must have a frequency stability of 0.5 ppm.

⁸ In the 421-512 MHz band, mobile stations designed to operate with a 12.5 kHz channel bandwidth must have a frequency stability of 2.5 ppm. Mobile stations designed to operate with a 6.25 kHz channel bandwidth must have a frequency stability of 1.0 ppm.

b) For the purpose of determining the frequency stability limits, the power of a transmitter is considered to be the maximum rated output power as specified by the manufacturer.

3.6.2 Test procedure

- 1) The transmitter was set up to the normal operational mode with maximum output power with no modulation signal applied.
- 2) The transmitter was connected to the Frequency meter HM8123 for measuring the frequency.
- 3) The transmitter was placed in the temperature chamber to observe the frequency stability across the temperature range.

3.6.3 Test setup layout

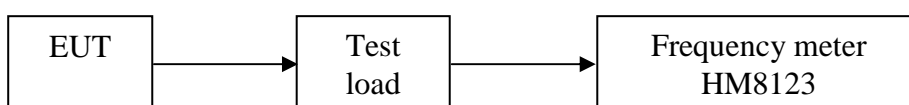

3.6.4 Test result

Temperature: +23 °C

Relative humidity: 47 %

Table 3.6.1

Temperature (°C)	Frequency (MHz)	Deviation (Hz)	Deviation (ppm)	Limit, ppm	Result (Pass, Fail, N/A)
+85	460.000124	124	0.270	0.5	Pass
+80	460.000086	86	0.187	0.5	Pass
+70	460.000068	68	0.147	0.5	Pass
+60	460.000049	49	0.106	0.5	Pass
+50	460.000087	87	0.189	0.5	Pass
+40	460.000116	116	0.252	0.5	Pass
+30	460.000057	57	0.124	0.5	Pass
+20	460.000029	29	0.063	0.5	Pass
+10	459.999879	- 121	- 0.263	0.5	Pass
0	459.999958	- 42	- 0.091	0.5	Pass
- 10	460.000129	129	0.280	0.5	Pass
- 20	460.000019	19	- 0.041	0.5	Pass
- 30	459.999936	- 64	0.139	0.5	Pass
- 40	No Transmission	-	-	-	N/A
+20	460.000029	29	+0.063	0.5	Pass

Reference frequency = 460.0 MHz

3.7 Operating Frequencies

Assignment and use of the frequencies in the band 450-470 MHz for fixed operations regulates by paragraph 47 CFR Part 90.261 and authorized in an individual license for the radio.

3.8 99% Occupied Bandwidth

3.8.1 Test Setup

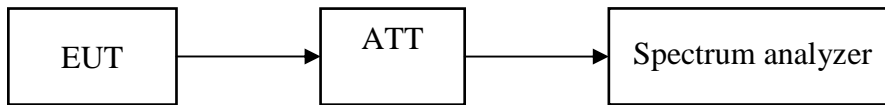

3.8.2 Limit

According to §90.209(b)(5) the maximum occupied bandwidth for a 6.25 kHz channel spacing is 6 kHz.

3.8.3 Test Procedure

The following procedure shall be used for measuring 99% power bandwidth.

Settings for the spectrum analyzer:

- center frequency is set to the nominal EUT channel center frequency;
- frequency span for the spectrum analyzer shall be between 1.5 times and 5.0 times the occupied bandwidth (OBW);
- RBW shall be in the range of 1% to 5% of the OBW, and VBW shall be approximately three times the RBW;
- Set the reference level of the instrument as required, keeping the signal from exceeding the maximum input mixer level for linear operation. The peak of the spectral envelope shall be more than $[10 \log (\text{OBW}/\text{RBW})]$ below the reference level.
- Peak detection and max hold mode (until the trace stabilizes) shall be used.
- The 99% power bandwidth function of the spectrum analyzer shall be used.

3.8.4 Test Results

Temperature: +25 °C

Relative humidity: 60 %

Channel Frequency, MHz	99% Occupied Bandwidth, kHz	Limit, kHz	Test Result (Pass, Fail, N/A)
450	3.64	6.00	Pass
460	3.59	6.00	Pass
470	3.68	6.00	Pass

Low Channel Plot

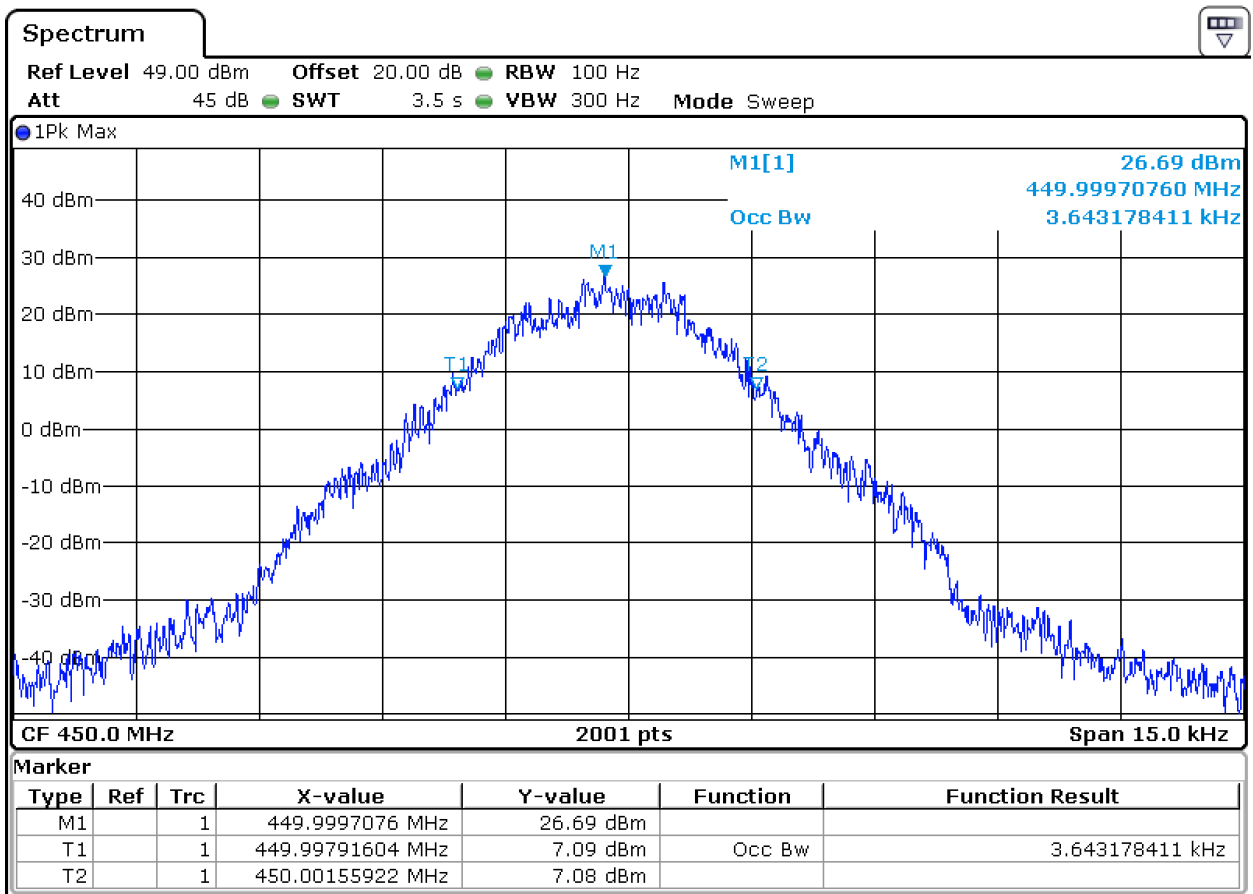

Middle Channel Plot

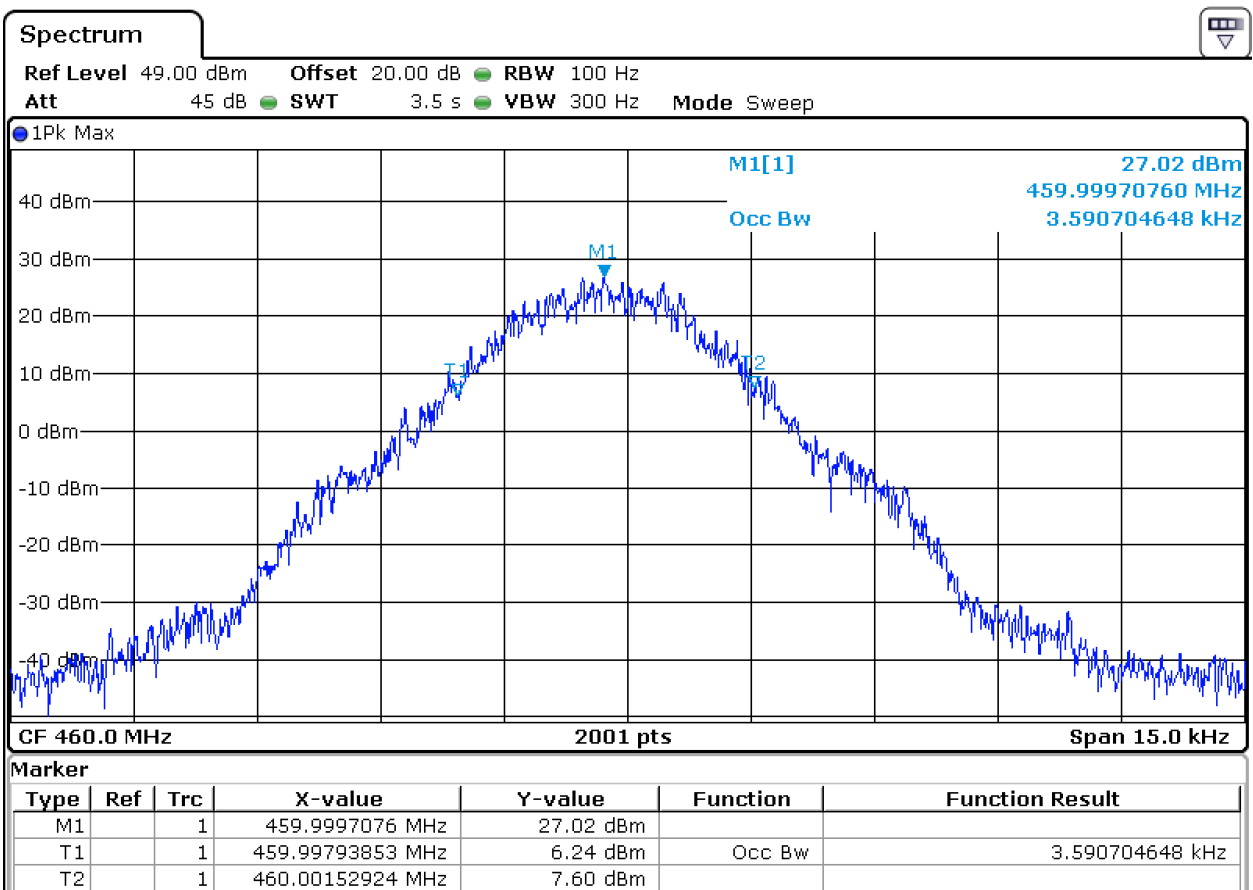

High Channel Plot

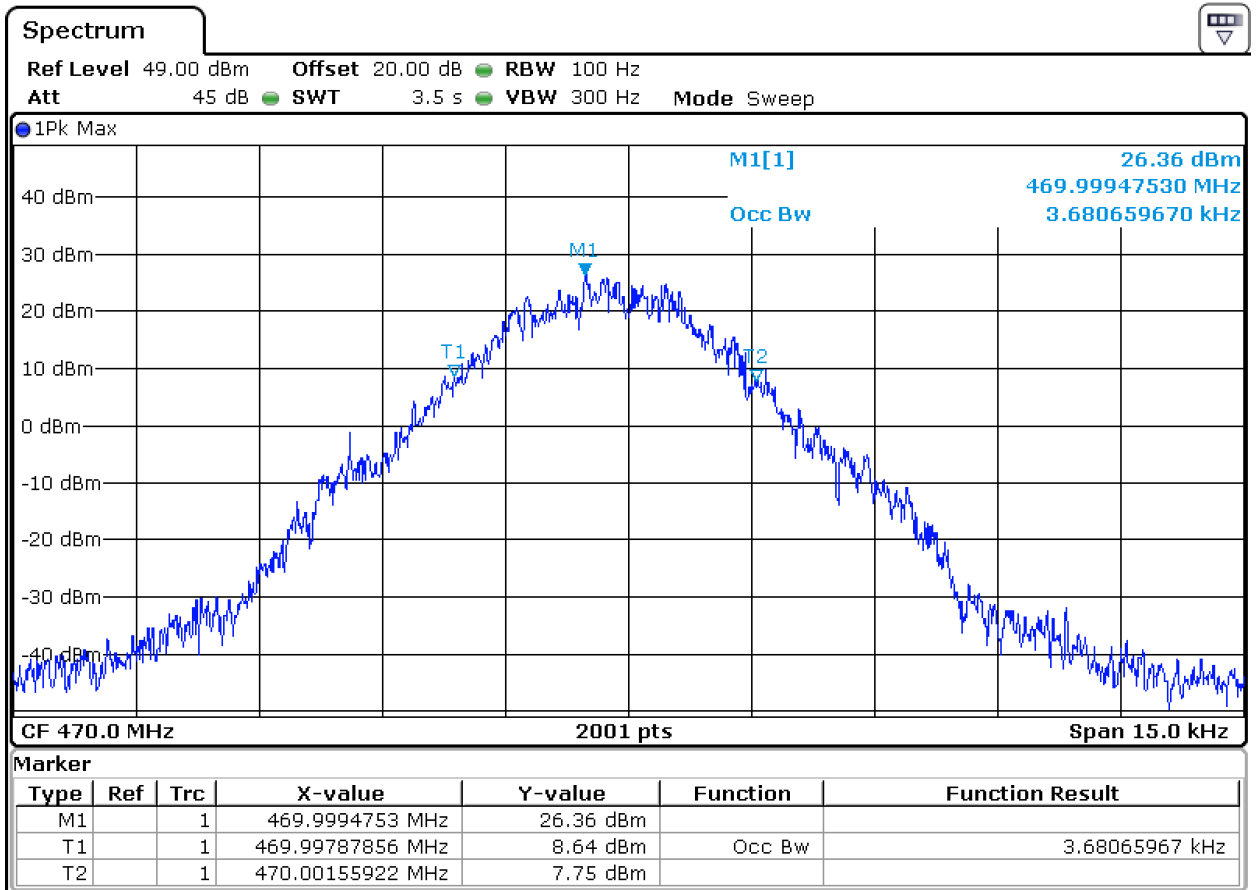

4 REPORT OF MEASUREMENTS AND EXAMINATIONS OF THE RECEIVER

4.1 Radiated Emission

4.1.1 Test requirements 15.109 Class B

Table 4.1.1 Limits Radiated Emission 15.109 Class B

Frequency of emission (MHz)	Field strength (microvolts/meter)	Field strength (dB μ V/m)
30-88	100	40
88-216	150	43.5
216-960	200	46
Above 960	500	54

4.1.2 Test procedure (ANSI/TIA 603-D:2010)

The test was performed to measure radiated emissions from the equipment under test enclosure. The measurement was made in the anechoic chamber at measurement distance of 3m in two bands: (30-1000) MHz, (1000-6000) MHz.

- 1) The equipment under test was set to stand-by mode.
- 2) In the band of (30-1000) MHz the measurement was made in anechoic chamber with metal floor. The turntable was rotated, the antenna height was altered in the range of 1m - 4m, the polarization of biconical antenna was changed from horizontal to vertical in a process of seeking for the maximum result. Settings of the test receiver: RBW = 120 kHz; Video Detector = Positive Peak during prequalification measurement, Quasi-Peak - during final measurement.
- 3) In the band of (1000-6000) MHz the measurement was made in fully anechoic chamber. The height of test antenna was fixed while the turntable was rotated and the polarization of horn test antenna was changed from horizontal to vertical in a process of seeking for the maximum result. Settings of the test receiver: RBW = 1000 kHz; Video Detector = Positive Peak during prequalification measurement, Average - during final measurement.
- 4) The worst test results (the lowest margins) were recorded and shown in the associated plots.

Figure 4.1.1 Test setup layout (above 30 MHz and below 6 GHz)

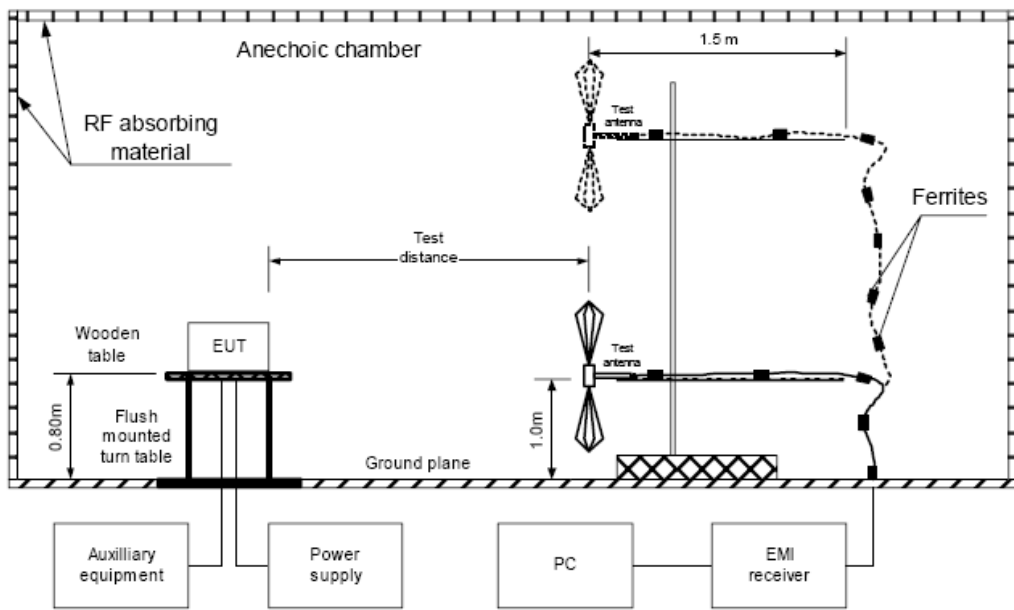

4.1.3 Test result

Temperature: +19 °C

Relative humidity: 69 %

EUT OPERATING MODE: Receive / Stand-by

Table 4.1.2 Radiated emission test result

Frequency, MHz	Turntable position, degrees	Antenna height, m	Antenna polarization	Peak detector emission, dB μ V/m	Quasi-Peak Detector Emission, dB μ V/m	Average detector emission, dB μ V/m	Limit, dB μ V/m	Result (Pass, Fail, N/A)
36.520000	0	200.0	V	-	24.0	-	40.0	Pass
53.600000	0	100.0	V	-	19.9	-	40.0	Pass
85.640000	0	300.0	H	-	16.3	-	40.0	Pass
95.680000	0	300.0	H	-	22.6	-	43.5	Pass
148.320000	90	100.0	V	-	29.9	-	43.5	Pass
148.720000	90	100.0	V	-	29.8	-	43.5	Pass
148.920000	90	100.0	V	-	29.7	-	43.5	Pass
149.320000	180	100.0	V	-	29.9	-	43.5	Pass
150.200000	0	100.0	V	-	29.3	-	43.5	Pass
150.440000	0	100.0	V	-	29.4	-	43.5	Pass
151.280000	0	100.0	V	-	29.4	-	43.5	Pass
152.440000	270	100.0	V	-	28.6	-	43.5	Pass
153.160000	0	100.0	V	-	28.6	-	43.5	Pass
173.440000	90	100.0	V	-	21.8	-	43.5	Pass
245.960000	180	100.0	H	-	12.6	-	46.0	Pass
409.600000	0	100.0	H	-	17.7	-	46.0	Pass
641.640000	0	200.0	V	-	17.0	-	46.0	Pass
913.000000	0	400.0	V	-	20.5	-	46.0	Pass
1153.647368	0	200.0	V	42.6	-	29.6	54.0	Pass
1393.521659	0	100.0	V	43.8	-	30.9	54.0	Pass
1696.785665	90	150.0	V	45.8	-	31.9	54.0	Pass
2027.182171	80	400.0	H	47.8	-	34.2	54.0	Pass
2395.431283	90	300.0	V	49.6	-	36.4	54.0	Pass
2757.964308	0	150.0	V	52.5	-	38.6	54.0	Pass
3331.419205	90	400.0	H	55.6	-	42.2	54.0	Pass
4068.597997	90	200.0	H	58.8	-	45.2	54.0	Pass
5003.787054	90	350.0	V	60.0	-	47.8	54.0	Pass
5972.147605	0	150.0	V	64.1	-	51.6	54.0	Pass

Plot 4.1.1 Radiated emission measurements in (30 – 1000) MHz range, vertical and horizontal polarization

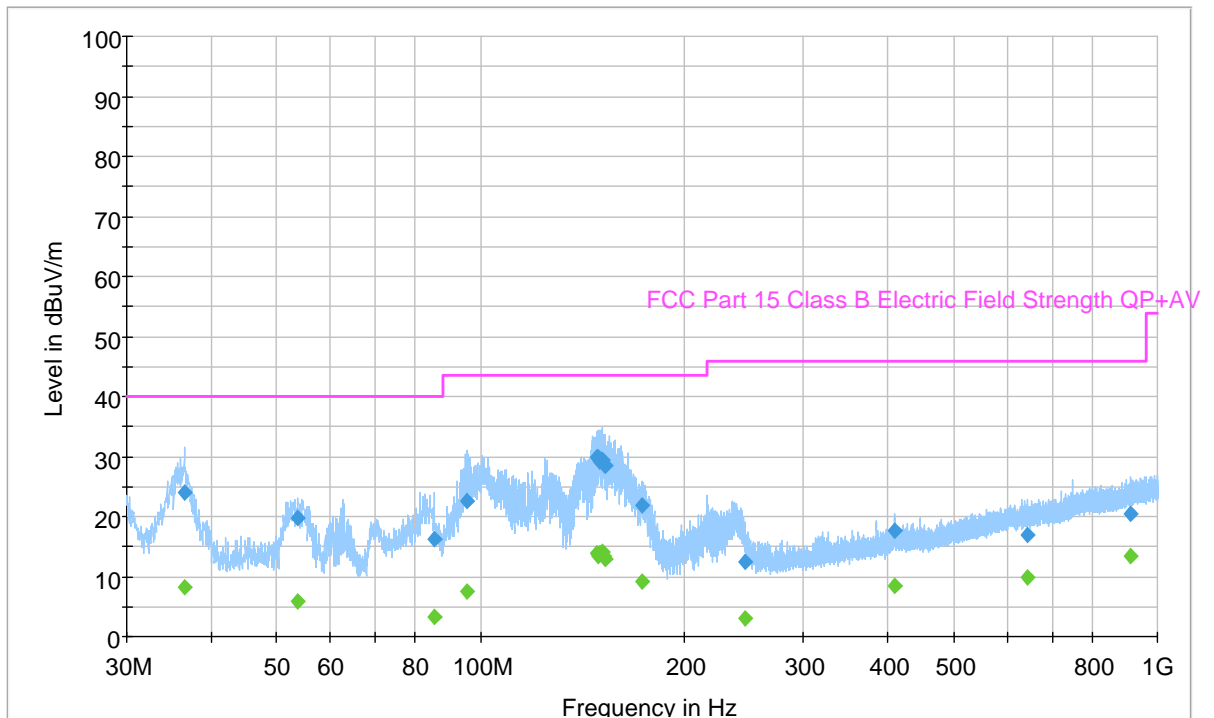

Plot 4.1.2 Radiated emission measurements in (1000 – 6000) MHz range, vertical and horizontal polarization

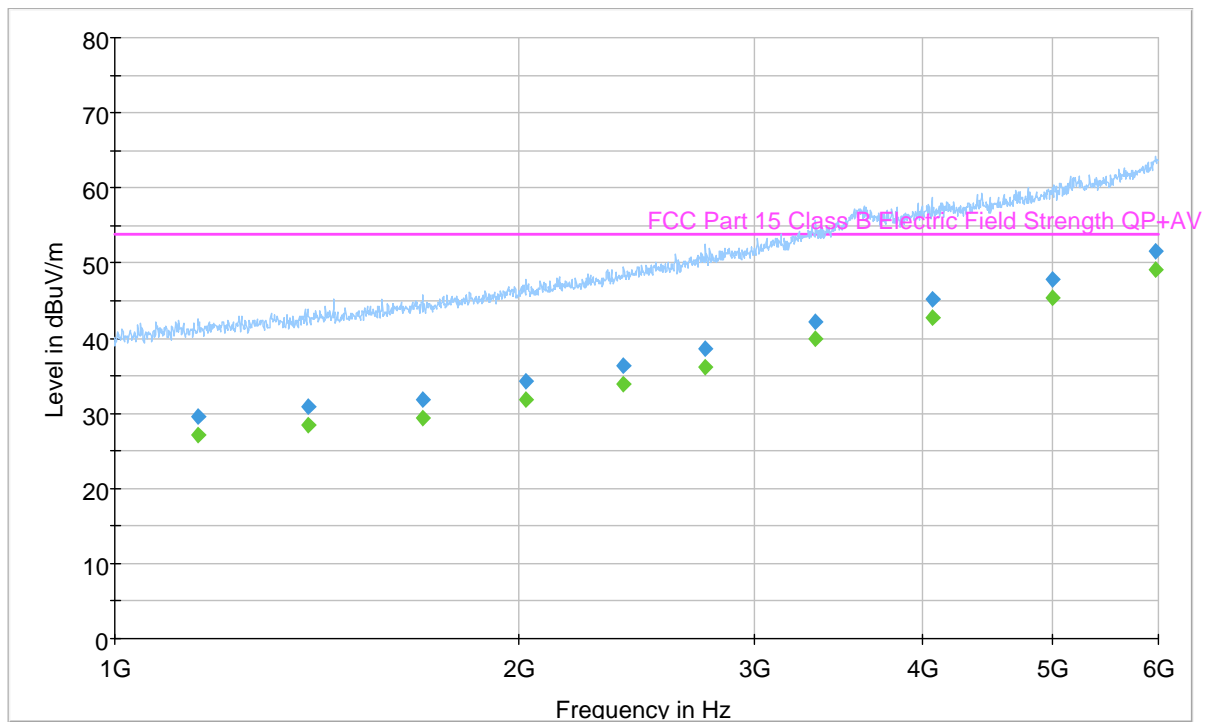

4.2 Antenna power conducted emissions

4.2.1 Test requirements Part 15 Section 15.111

(a) In addition to the radiated emission limits, receivers that operate (tune) in the frequency range 30 to 960 MHz and CB receivers that provide terminals for the connection of an external receiving antenna may be tested to demonstrate compliance with the provisions of Section 15.109 with the antenna terminals shielded and terminated with a resistive termination equal to the impedance specified for the antenna, provided these receivers also comply with the following: with the receiver antenna terminal connected to a resistive termination equal to the impedance specified or employed for the antenna, the power at the antenna terminal at any frequency within the range of measurements specified in Section 15.33 shall not exceed 2.0 nanowatts.

(b) CB receivers and receivers that operate (tune) in the frequency range 30 to 960 MHz that are provided only with a permanently attached antenna shall comply with the radiated emission limitations in this Part, as measured with the antenna attached.

Table 4.2.1 Limit Antenna Power Conducted emissions FCC 47 CFR Part 15 section 15.111 (a)

Frequency range	Limit nW	Remark
9 kHz – 150 kHz	2	RBW 200 Hz
150 KHz – 30 MHz		RBW 10 kHz
30 MHz – 1 GHz		RBW 120 kHz
1 GHz – 2 GHz		RBW 1 MHz

4.2.2 Test procedure (ANSI/TIA 603-D:2010)

The spectrum shall be investigated from the lowest radio frequency signal generated or used in the device, without going below the lowest frequency for which a radiated emission limit is specified, up to the frequency shown in the following table:

Highest frequency generated or used in the device or which the device operates or tunes (MHz)	Upper frequency of measurement range (MHz)
Below 108	1000
108 – 500	2000
500 – 1000	5000
Above 1000	5 th harmonic of the highest internally digital device operating frequency

4.2.3 Test setup layout

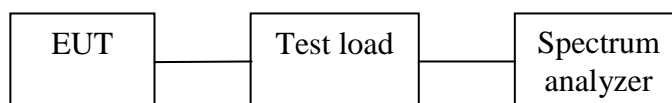

4.2.4 Test result

Temperature: +23 °C

Relative humidity: 47 %

Plot 4.2.1: Frequency range 9kHz-150kHz

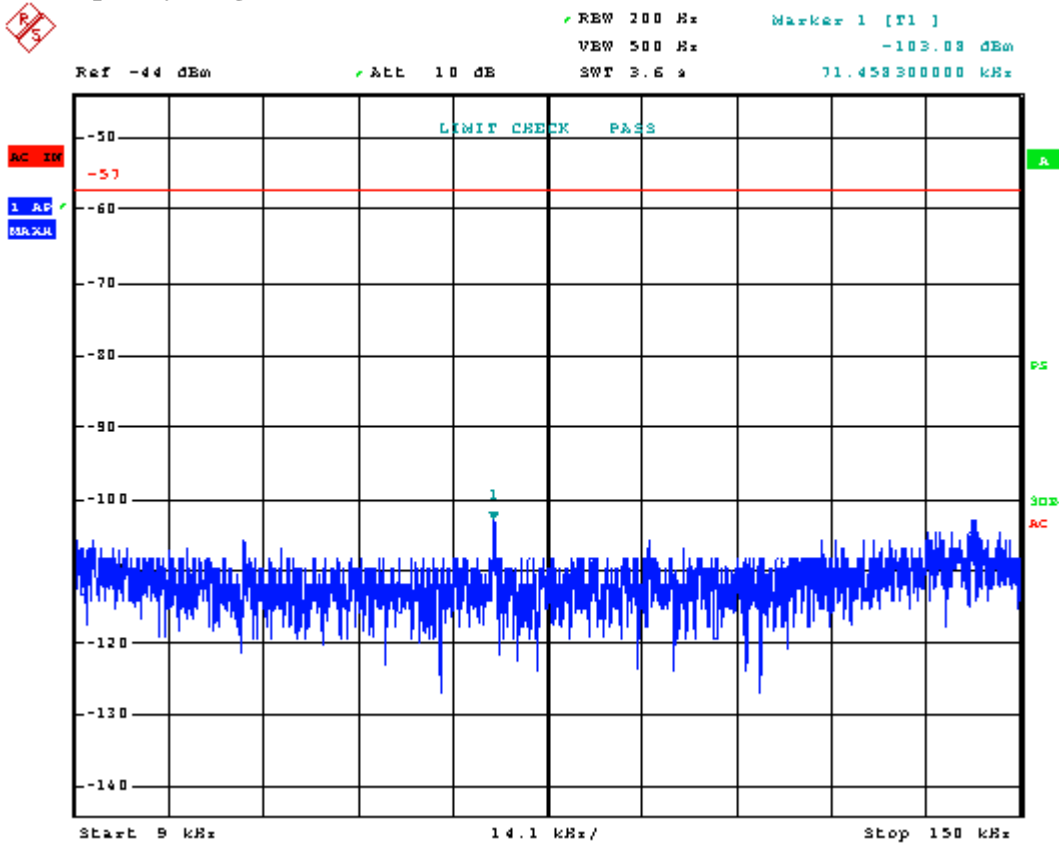

Plot 4.2.2: Frequency range 150Khz-30MHz

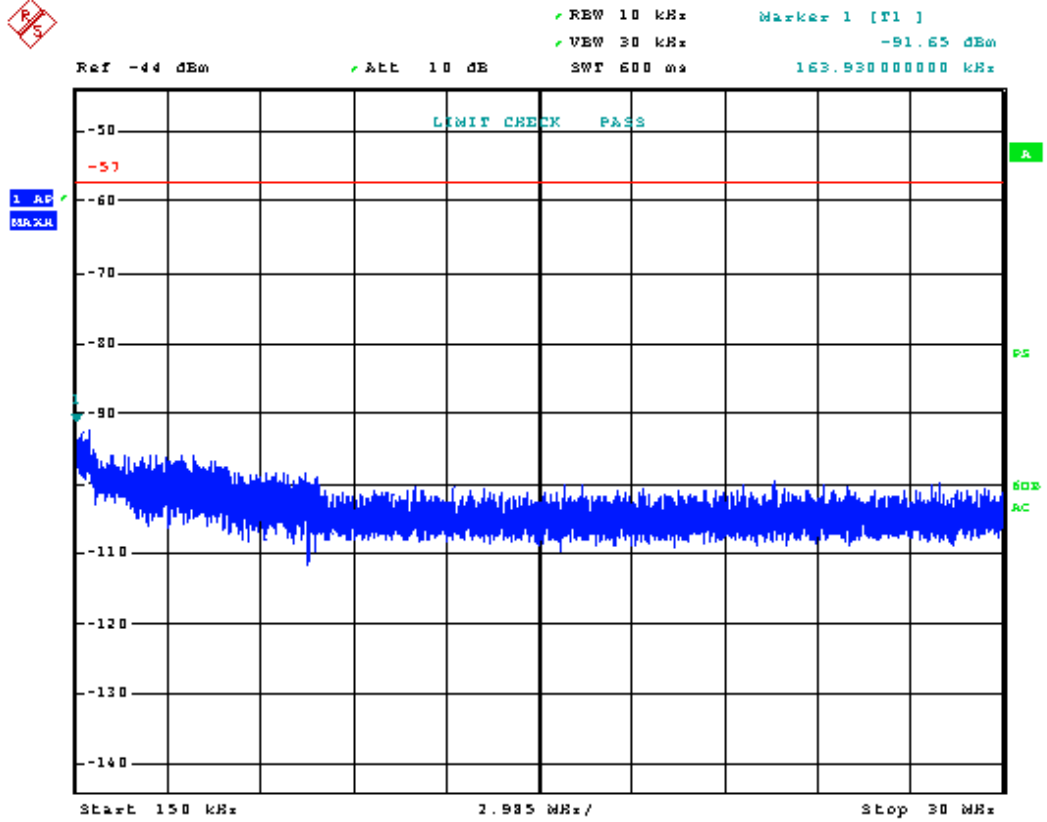

Plot 4.2.3: Frequency range 30MHz-1GHz

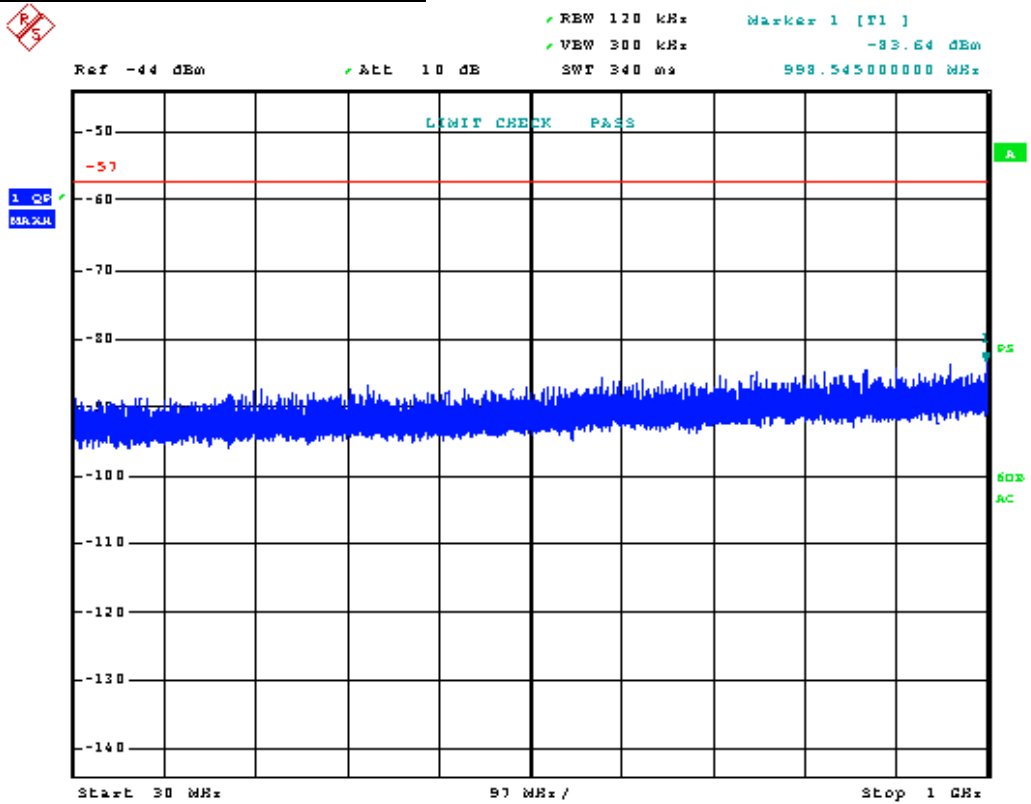

Plot 4.2.4: Frequency range 1GHz - 2 GHz

