

FCC TEST REPORT No. 14/988	2014
for 47 CFR Part 90	November, 28

Model name: LCU NEMA
Product description: Street Light Control Unit
FCC ID: NTA2WLCUN
Applicant: Telematics Wireless Ltd., Israel
Manufacturer: Telematics Wireless Ltd., Israel

*The results in this report apply only to the samples tested.
Reproduction or copying of this report or its any part may only be made
with the prior
written approval of PE TC "Omega"*

PUBLIC ENTERPRISE
TESTING CENTER
"OMEGA"

29 Vakulenchuk str., Sevastopol,
99053, Crimea, Ukraine, P.O.B.-37
phone: +380 692 53 70 72
fax: +380 692 46 96 79
e-mail: stcomega@stc-omega.biz

Approved by
Sergey Bogach,
Chief TC of PE TC "OMEGA"



Table of contents

1 EQUIPMENT UNDER TEST	3
<u>1.1 BASIC DESCRIPTION</u>	3
<u>1.2 TECHNICAL CHARACTERISTICS DECLARED BY MANUFACTURER</u>	3
<u>1.3 PHOTOS</u>	4
2 GENERAL INFORMATION ABOUT TESTS	5
<u>2.1 TEST PROGRAM AND RESULTS OF THE TESTS</u>	5
<u>2.2 TEST CONDITIONS AND TEST MODES</u>	5
<u>2.3 TEST EQUIPMENT USED</u>	6
<u>2.4 MEASUREMENT UNCERTAINTY</u>	6
<u>2.5 PHOTO OF THE TEST SITE</u>	7
3 REPORT OF MEASUREMENTS AND EXAMINATIONS	8
3.1 EMISSION MASK	8
3.2 CONDUCTED SPURIOUS EMISSIONS	11
3.3 RADIATED SPURIOUS EMISSIONS	16
3.4 CONDUCTED EMISSION	20
3.5 CONDUCTED EMISSIONS	28
3.6 RADIATED EMISSION	32
3.7 TRANSIENT STABILITY	35
3.8 FREQUENCY STABILITY VS POWER SUPPLY	40
3.9 FREQUENCY STABILITY VS TEMPERATURE	42
3.10 99% OCCUPIED BANDWIDTH	44
3.11 OPERATING FREQUENCIES	46

1 EQUIPMENT UNDER TEST

1.1 Basic description

Equipment Category	Transceiver
Model name	LCU NEMA
Destination	Street Light Control Unit
Configuration	stand-alone device
Serial numbers	n/a

1.2 Technical characteristics declared by manufacturer

Table 1.2.1 Parameters of the Receiver

Parameter	Value
Receive frequency	Programmable 450-470 MHz
Sensitivity (BER 1E-3)	-120 dBm
Modulation	4GFSK
Max Frequency deviation	1.2 kHz
Bit rate	4.8 kbps
Frequency stability (including initial stability, temperature and aging)	<0.5 ppm

Table 1.2.2 Parameters of the Transmitter

Parameter	Value
Transmit Frequency band	450-470 MHz
Modulation	4GFSK
Max Data rate	4.8 kbps
Chip rate	2.4 kChip/sec
Channel Separation	6.25 kHz
Frequency stability (including initial stability, temperature)	<0.5 ppm
Peak Output power	34 dBm max.
Type of emission	5K10F1D
Harmonics	< - 62 dBc

Internal printed antenna

Type Omni Directional
Gain 0dBi

1.3 Photos

Figure 1.3.1 External photo



Figure 1.3.2 Internal photo

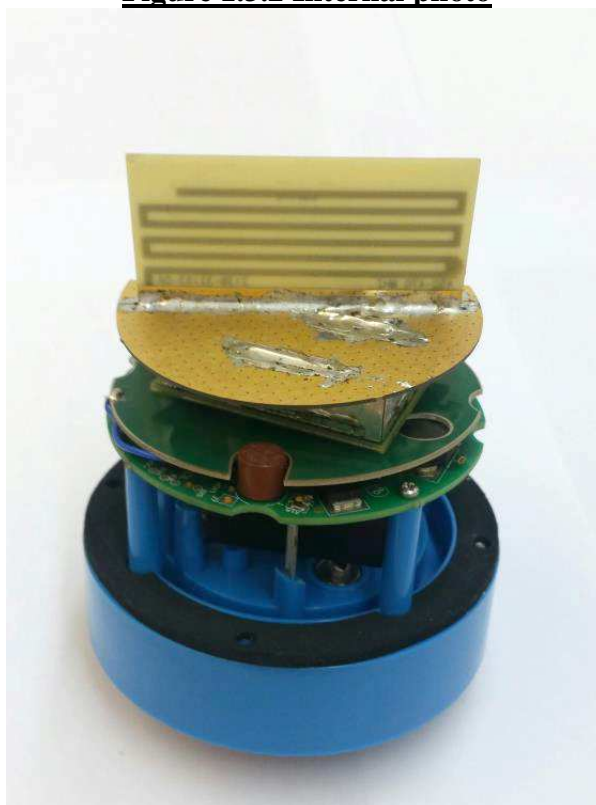

2 GENERAL INFORMATION ABOUT TESTS

2.1 Test program and results of the tests

Number of test	FCC rule	Description of test	Result (Pass, Fail, N/A)
1	90.210(e)	Emission Mask	Pass
2	90.210(e)	Conducted Spurious Emissions	Pass
3	90.210(e)	Radiated Spurious Emissions	Pass
4	15.207(a)	Conducted Emissions	Pass
5	15.107(a)	Conducted Emissions	Pass
6	15.109 Class B	Radiated Emissions	Pass
7	90.214	Transient Frequency Stability	Pass
8	90.213	Frequency Stability with supply voltage	Pass
9	90.213	Frequency Stability with temperature	Pass
10	90.209(b)(5)	99% Occupied Bandwidth	Pass
11	90.261	Operating Frequencies	Pass

Tested by:

tests No. 1, 2, 7-11: Laboratory engineer

 Boris Trifonov

tests No. 3-6: Laboratory engineer



Vladimir Osaulko

Checked by:

Leading engineer



Fjodor Shubin

2.2 Test conditions and test modes

Operating Temperature: -30 °C to +85 °C

Storage Temperature: -40 °C to +85 °C

Humidity: Up to 95%

Nominal power source:

- $U_{nom} = 120.0 \text{ VAC}$

Extreme temperature:

- minimum temperature $T_{min} = \text{minus } 30 \text{ }^\circ\text{C}$;

- maximum temperature $T_{max} = +85 \text{ }^\circ\text{C}$.

Extreme power source:

- minimum voltage $U_{min} = 108.0 \text{ VAC}$

- maximum voltage $U_{max} = 132.0 \text{ VAC}$

The frequencies for the testing

Channel, No.	Frequency, MHz
Low	450
Mid	460
High	470

2.3 Test equipment used

№	Name	Model	Inventory or serial No.
1.	EMI Test receiver/spectrum analyzer	R&S ESU-26	100260
2.	Spectrum analyzer	R&S FSV40	105763
3.	Radiocommunication service monitor	R&S CMS-54	100033
4.	Vector Signal Generator	SMJ100A	101127
5.	Signal Generator	SMB100A	100217
6.	Oscilloscope	TDS1002	C041673
7.	Frequency meter	R&S HM8123	100269
8.	Dual directional coupler	778D-012	101895
9.	Attenuator	Agilent 8496B	100103
10.	Attenuator	6N25W	100196
11.	Attenuator	PE7014-10	101692
12.	Detector	Agilent 8471E	100104
13.	RF Trigger	-	111008
14.	Antenna (30 – 1000) MHz	Schwarzbeck UBAA 9114	9111-214
15.	Antenna (30 – 1000) MHz	Schwarzbeck VULB9163	9163244
16.	Antenna (1000 - 6000) MHz	ETS-Lindgren 3117	100200
17.	Antenna (1000 - 6000) MHz	ETS-Lindgren 3117	100201
18.	Digital multimeter	FLUKE 189	89750179
19.	Preamplifier (0.1-18) GHz	Agilent 87405c	MY47010400
20.	Psychrometer	BIT-2	B931
21.	Shielded Semi-Anechoic Chamber	"DON"	1

All listed above test equipment is calibrated and certified in accordance with established procedure. The equipment has certificates currently in force.

Ancillary equipment

№	Name	Model
1.	Test load	Telematics Wireless RTU_S
2.	Notebook	IBM ThinkPad

2.4 Measurement uncertainty

Parameter	Maximum uncertainty
Radiated emission	± 5.2 dB
Conducted emission	± 2.7 dB
Frequency	$\pm 1 \times 10^{-8}$
Temperature	± 1 °C
Humidity	± 2 %
Voltage supply DC	± 2 %

This uncertainty represents an expanded uncertainty expressed at approximately the 95 % confidence level using a coverage factor of k=2.

2.5 Photo of the test site

Figure 2.5.1 Radiated measurements



Figure 2.5.2 Conducted measurements



3 REPORT OF MEASUREMENTS AND EXAMINATIONS

3.1 Emission mask

3.1.1 Test requirements 90.210(e)

Except as indicated elsewhere in this part, transmitters used in the radio services governed by this part must comply with the emission masks outlined in this section. Unless otherwise stated, per paragraphs (d)(4), (e)(4), and (m) of this section, measurements of emission power can be expressed in either peak or average values provided that emission powers are expressed with the same parameters used to specify the unmodulated transmitter carrier power. For transmitters that do not produce a full power unmodulated carrier, reference to the unmodulated transmitter carrier power refers to the total power contained in the channel bandwidth. Unless indicated elsewhere in this part, the table in this section specifies the emission masks for equipment operating in the frequency bands governed under this part.

Table 3.1.1 Limit Emissions Mask

Frequency band (MHz)	Mask for equipment with Audio low pass filter	Mask for equipment without audio low pass filter
Below 25 ¹	A or B	A or C
25-50	B	C
72-76	B	C
150-174 ²	B, D, or E	C, D, or E
150 Paging-only	B	C
220-222	F	F
421-512 ²	B, D, or E	C, D, or E
450 Paging-only	B	G
806-809/851-854	B	H
809-824/854-869 ³	B	G
896-901/935-940	I	J
902-928	K	K
929-930	B	G
4940-4990 MHz	L or M	L or M.
5850-5925 ⁴		
All other bands	B	C

² Equipment designed to operate with a 25 kHz channel bandwidth must meet the requirements of Emission Mask B or C, as applicable. Equipment designed to operate with a 12.5 kHz channel bandwidth must meet the requirements of Emission Mask D, and equipment designed to operate with a 6.25 kHz channel bandwidth must meet the requirements of Emission Mask E.

(e) Emission Mask E—6.25 kHz or less channel bandwidth equipment. For transmitters designed to operate with a 6.25 kHz or less bandwidth, any emission must be attenuated below the power (P) of the highest emission contained within the authorized bandwidth as follows:

- (1) On any frequency from the center of the authorized bandwidth f_0 to 3.0 kHz removed from f_0 : Zero dB.
- (2) On any frequency removed from the center of the authorized bandwidth by a displacement frequency (f_d in kHz) of more than 3.0 kHz but no more than 4.6 kHz: At least $30 + 16.67(f_d - 3 \text{ kHz})$ or $55 + 10 \log (P)$ or 65 dB, whichever is the lesser attenuation.
- (3) On any frequency removed from the center of the authorized bandwidth by more than 4.6 kHz: At least $55 + 10 \log (P)$ or 65 dB, whichever is the lesser attenuation.

(4) The reference level for showing compliance with the emission mask shall be established using a resolution bandwidth sufficiently wide (usually two to three times the channel bandwidth) to capture the true peak emission of the equipment under test. In order to show compliance with the emissions mask up to and including 50 kHz removed from the edge of the authorized bandwidth, adjust the resolution bandwidth to 100 Hz with the measuring instrument in a peak hold mode. A sufficient number of sweeps must be measured to insure that the emission profile is developed. If video filtering is used, its bandwidth must not be less than the instrument resolution bandwidth. For emissions beyond 50 kHz from the edge of the authorized bandwidth, see paragraph (m) of this section. If it can be shown that use of the above instrumentation settings do not accurately represent the true interference potential of the equipment under test, then an alternate procedure may be used provided prior Commission approval is obtained.

3.1.2 Test procedure

- 1) The transmitter output was connected to the test load and then to the spectrum analyzer.
- 2) The transmitter was set up to the normal operational mode with maximum output power.
- 3) Spectrum analyzer was set to the measurement mode of Spectrum Emission Mask (SEM) with the following settings:
 - Centre frequency set to the center frequency of the channel
 - The Relative Mask setting was chosen
 - RBW=100 Hz, VBW=300 Hz, Video Detector = Peak, Trace = MAX HOLD.

3.1.3 Test setup layout

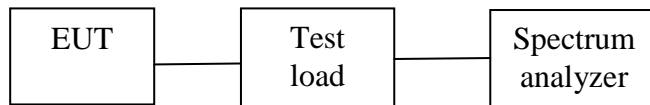

Figure 3.1.1

3.1.4 Test result

Temperature: +23 °C

Relative humidity: 47 %

3.1.4.1 Plots Emissions Mask test result at low frequency

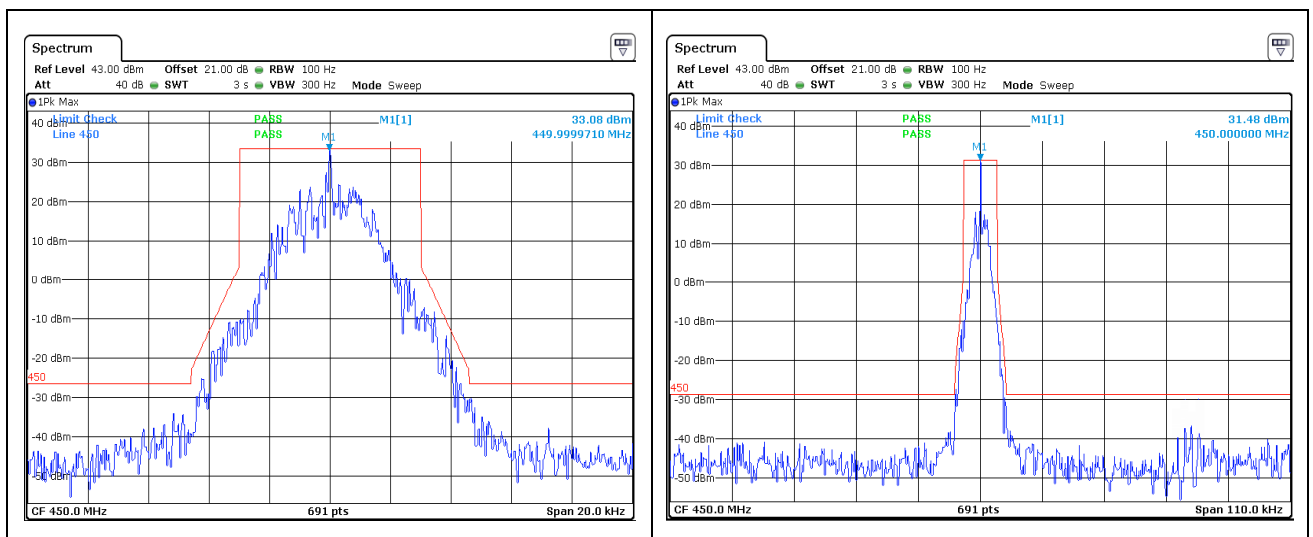

3.1.4.2 Plots Emissions Mask test result at mid frequency

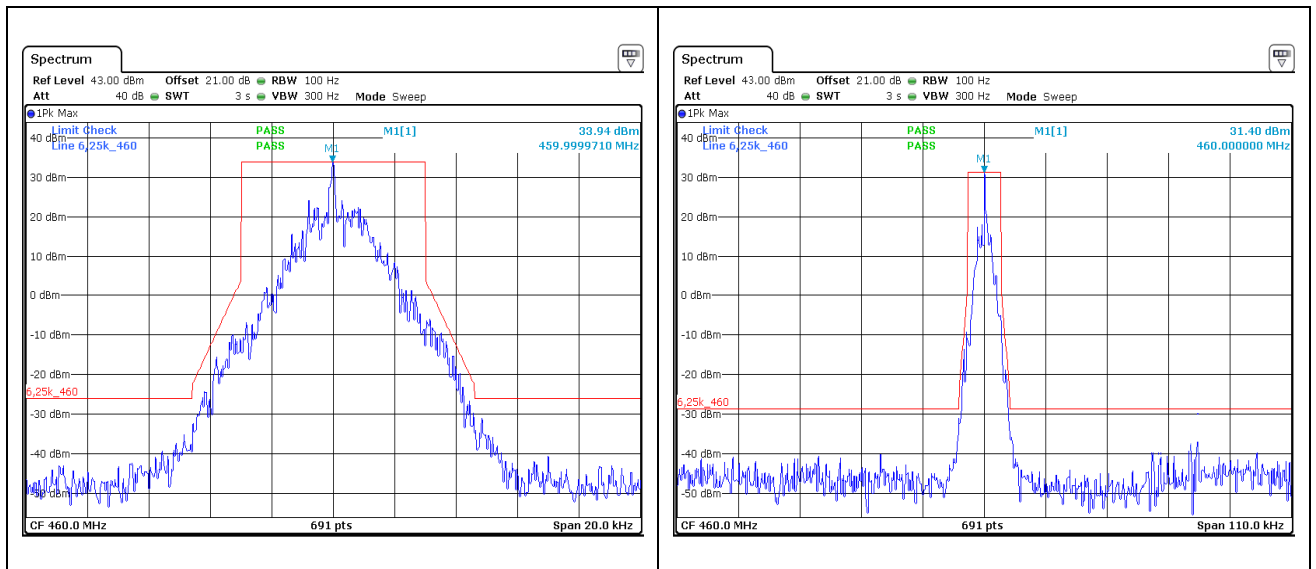

3.1.4.3 Plots Emissions Mask test result at high frequency

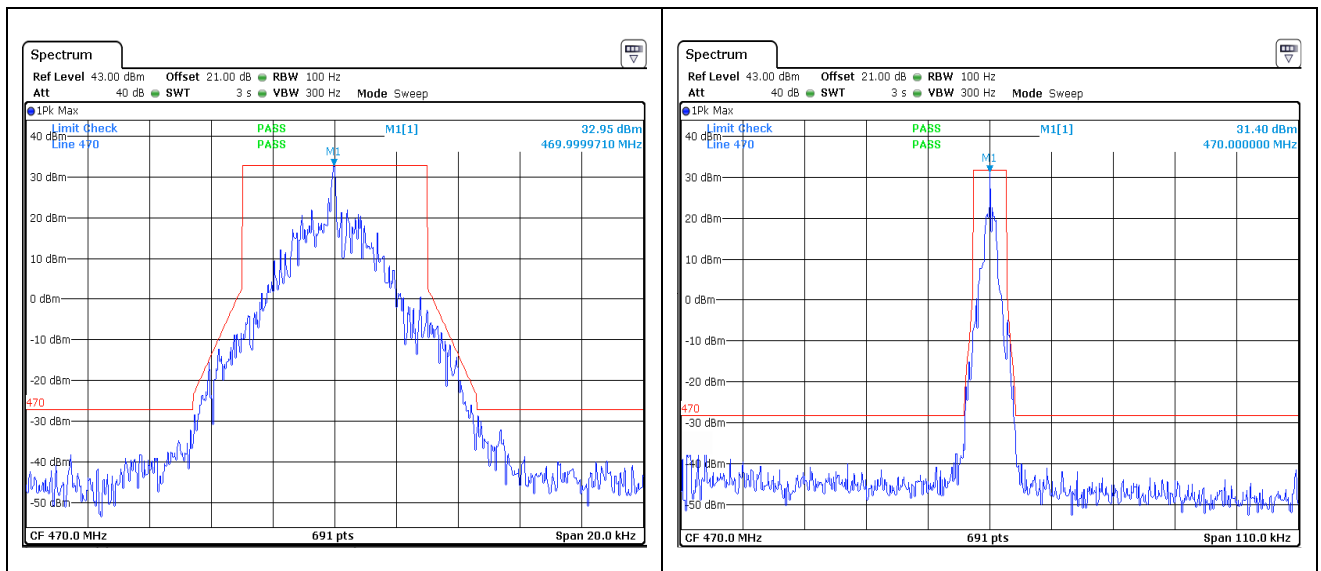

3.2 Conducted Spurious Emissions

3.2.1 Test requirements 90.210 (e)

Except as indicated elsewhere in this part, transmitters used in the radio services governed by this part must comply with the emission masks outlined in this section. Unless otherwise stated, per paragraphs (d)(4), (e)(4), and (m) of this section, measurements of emission power can be expressed in either peak or average values provided that emission powers are expressed with the same parameters used to specify the unmodulated transmitter carrier power. For transmitters that do not produce a full power unmodulated carrier, reference to the unmodulated transmitter carrier power refers to the total power contained in the channel bandwidth. Unless indicated elsewhere in this part, the table in this section specifies the emission masks for equipment operating in the frequency bands governed under this part.

Frequency band (MHz)	Mask for equipment with Audio low pass filter	Mask for equipment without audio low pass filter
Below 25 ¹	A or B	A or C
25-50	B	C
72-76	B	C
150-174 ²	B, D, or E	C, D, or E
150 Paging-only	B	C
220-222	F	F
421-512 ²	B, D, or E	C, D, or E
450 Paging-only	B	G
806-809/851-854	B	H
809-824/854-869 ³	B	G
896-901/935-940	I	J
902-928	K	K
929-930	B	G
4940-4990 MHz	L or M	L or M.
5850-5925 ⁴		
All other bands	B	C

² Equipment designed to operate with a 25 kHz channel bandwidth must meet the requirements of Emission Mask B or C, as applicable. Equipment designed to operate with a 12.5 kHz channel bandwidth must meet the requirements of Emission Mask D, and equipment designed to operate with a 6.25 kHz channel bandwidth must meet the requirements of Emission Mask E.

(e) Emission Mask E—6.25 kHz or less channel bandwidth equipment. For transmitters designed to operate with a 6.25 kHz or less bandwidth, any emission must be attenuated below the power (P) of the highest emission contained within the authorized bandwidth as follows:

(1) On any frequency from the center of the authorized bandwidth f_0 to 3.0 kHz removed from f_0 : Zero dB.

(2) On any frequency removed from the center of the authorized bandwidth by a displacement frequency (f_d in kHz) of more than 3.0 kHz but no more than 4.6 kHz: At least $30 + 16.67(f_d - 3 \text{ kHz})$ or $55 + 10 \log(P)$ or 65 dB, whichever is the lesser attenuation.

(3) On any frequency removed from the center of the authorized bandwidth by more than 4.6 kHz: At least $55 + 10 \log(P)$ or 65 dB, whichever is the lesser attenuation.

(4) The reference level for showing compliance with the emission mask shall be established using a resolution bandwidth sufficiently wide (usually two to three times the channel bandwidth) to capture the true peak emission of the equipment under test. In order to show compliance with the emissions mask up to and including 50 kHz removed from the edge of the authorized bandwidth, adjust the resolution bandwidth to 100 Hz with the measuring instrument in a peak hold mode. A sufficient number of sweeps must be measured to insure that the emission profile is developed. If video filtering is used, its bandwidth must not be less than the instrument resolution bandwidth. For emissions beyond 50 kHz from the edge of the authorized bandwidth, see paragraph (m) of this section. If it can be shown that use of the above instrumentation settings do not accurately represent the true interference potential of the equipment under test, then an alternate procedure may be used provided prior Commission approval is obtained.

3.2.2 Test procedure

The procedure used was ANSI/TIA-603-D:2010. Substitution RF signal generator was used.

- 1) The transmitter was connected to the spectrum analyzer using the test load.
- 2) The transmitter was set up to the normal operational mode with maximum output power rating.
- 3) The spurious emissions were observed in the band of +50 kHz from the edge of the authorized bandwidth to frequency equal 10 times the carrier frequency.

The spectrum analyzer was adjusted for the following settings:

Resolution Bandwidth = 10 kHz for spurious emission below 1 GHz, and 1 MHz for spurious emission above 1 GHz.

Video Bandwidth ≥ 3 times the resolution bandwidth.

Sweep Speed ≤ 2000 Hz per second.

Detector Mode = average power.

3.2.3 Test setup layout

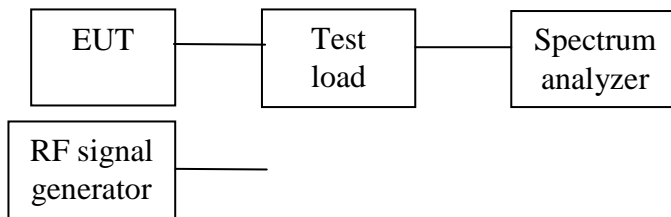

3.2.4 Test result

Temperature: +23 °C

Relative humidity: 47 %

Table 3.2.1

Frequency, MHz	Output Power (dB)	Gen. Output (dBm)	Difference, dBc	Limit, dBc	Result (Pass, Fail, N/A)
450	33.54	-	-	-	-
450.0564	- 30.02	- 30.80	- 64.34	- 60	Pass
450.2114	- 30.46	- 31.21	- 64.75	- 60	Pass
450.2476	- 32.23	- 33.04	- 66.58	- 60	Pass
460	33.66	-	-	-	-
460.0576	- 27.70	- 28.64	- 62.30	- 60	Pass
460.0899	- 29.25	- 30.15	- 63.81	- 60	Pass
460.1466	- 31.37	- 32.06	- 65.72	- 60	Pass
470	33.18	-	-	-	-
460.0525	- 29.21	- 30.18	- 63.36	- 60	Pass
470.0787	- 30.18	- 31.05	- 64.23	- 60	Pass
470.1455	- 31.80	- 32.79	- 65.97	- 60	Pass

3.2.1 Plot Output Power (Frequency 450 MHz)

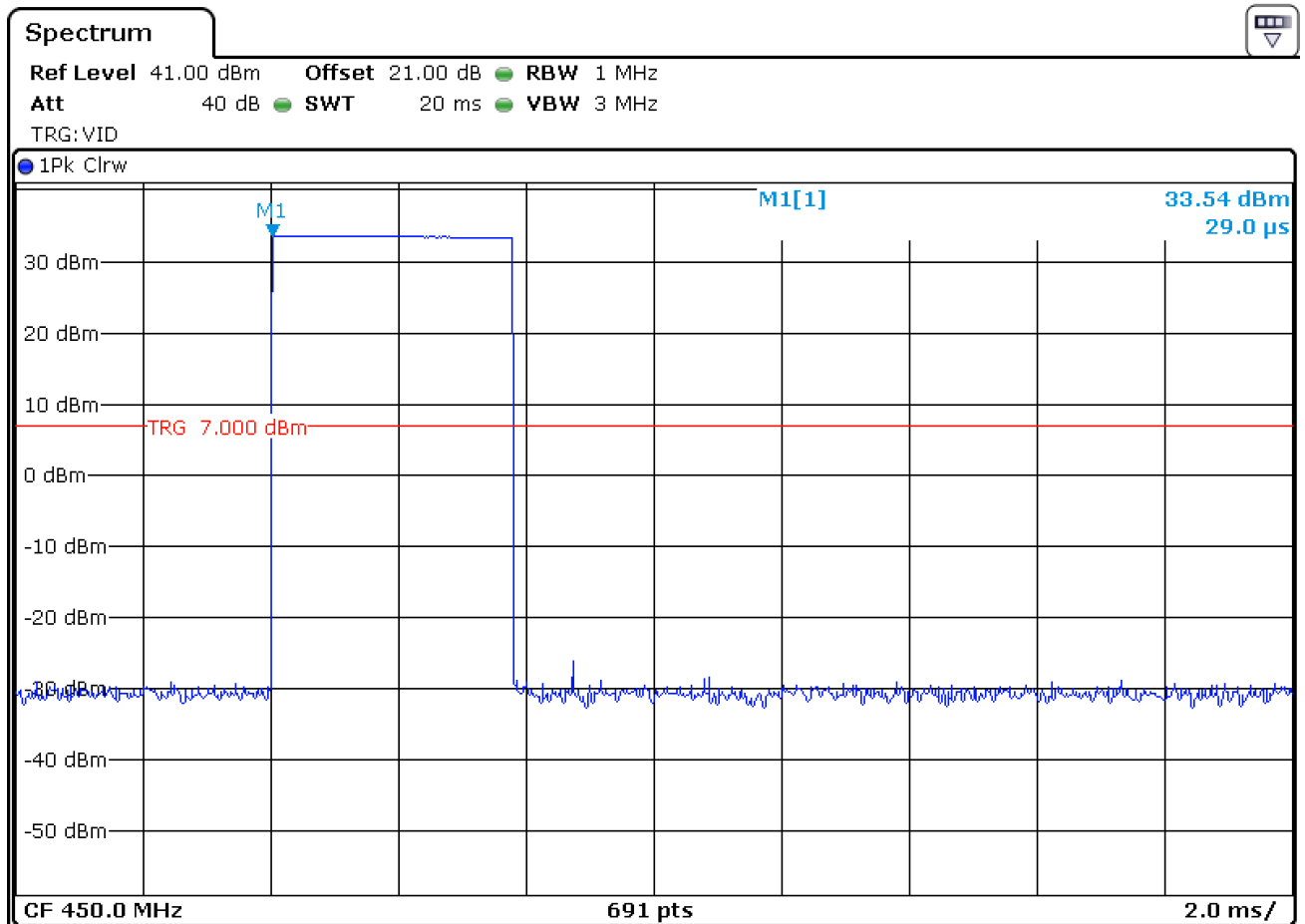

Table 3.2.2 Conducted Spurious Emissions (Frequency 450 MHz)

Frequency, MHz	Output Power, dBm	Gen. Output, dBm	Difference, dBc	Limit, dBc	Result (Pass, Fail, N/A)
450	33.54	-	-	-	-
900	- 42.03	- 42.70	- 76.24	- 60	Pass
1350	- 70.45	- 71.23	- 104.77	- 60	Pass
1800	- 71.83	- 72.64	- 106.18	- 60	Pass
2250	-	-	-	- 60	Pass
2700	-	-	-	- 60	Pass
3150	-	-	-	- 60	Pass
3600	-	-	-	- 60	Pass
4050	-	-	-	- 60	Pass
4500	-	-	-	- 60	Pass

3.2.2 Plot Output Power (Frequency 460 MHz)

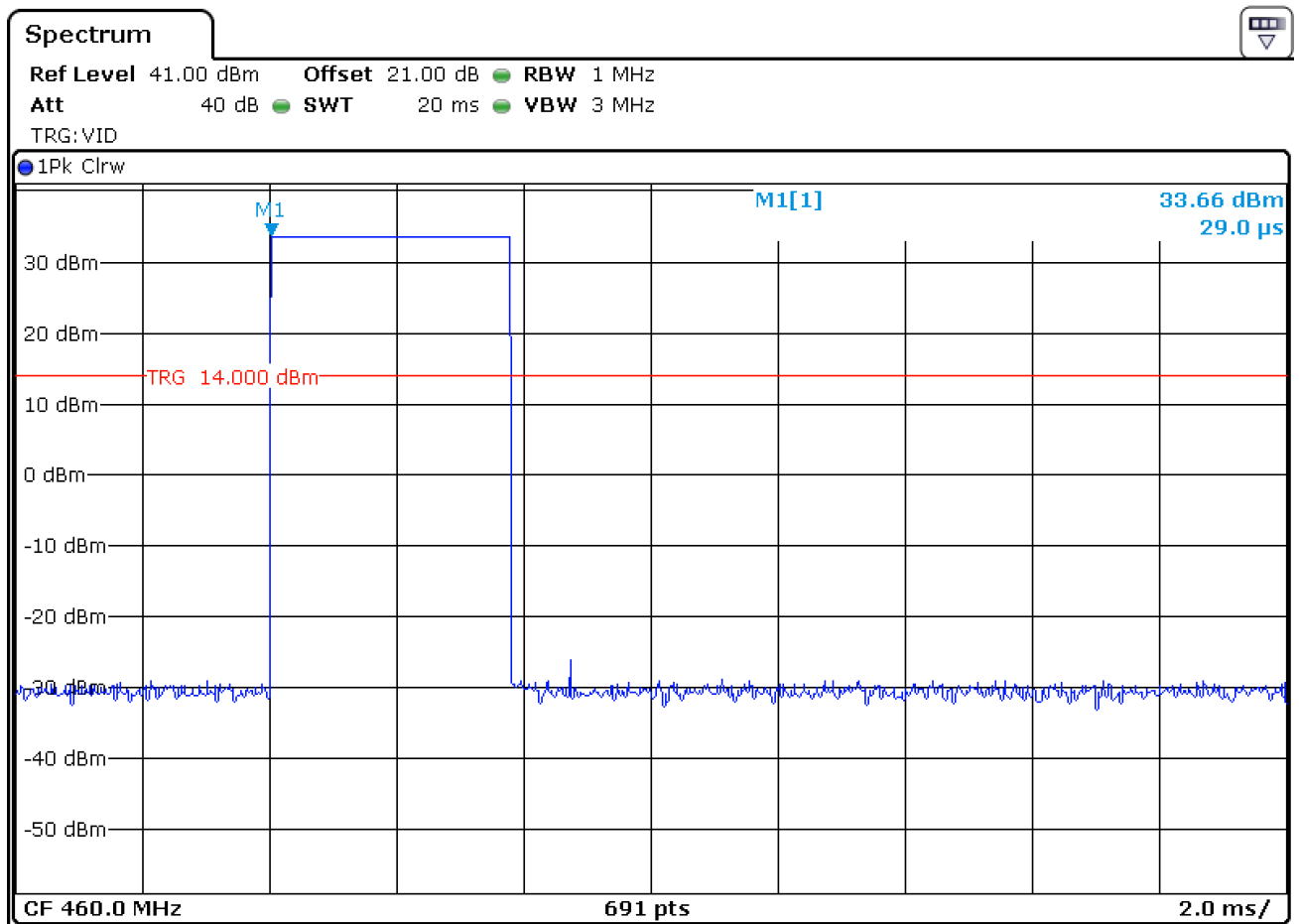

Table 3.2.3 Conducted Spurious Emissions (Frequency 460 MHz)

Frequency, MHz	Output Power, dBm	Gen. Output, dBm	Difference, dBc	Limit, dBc	Result (Pass, Fail, N/A)
460	33.66	-	-	-	-
920	- 41.92	- 42.05	- 75.71	- 60	Pass
1380	- 69.54	- 69.98	- 103.64	- 60	Pass
1840	- 71.28	- 71.76	- 105.42	- 60	Pass
2300	-	-	-	- 60	Pass
2760	-	-	-	- 60	Pass
3220	-	-	-	- 60	Pass
3680	-	-	-	- 60	Pass
4140	-	-	-	- 60	Pass
4600	-	-	-	- 60	Pass

3.2.3 Plot Output Power (Frequency 470 MHz)

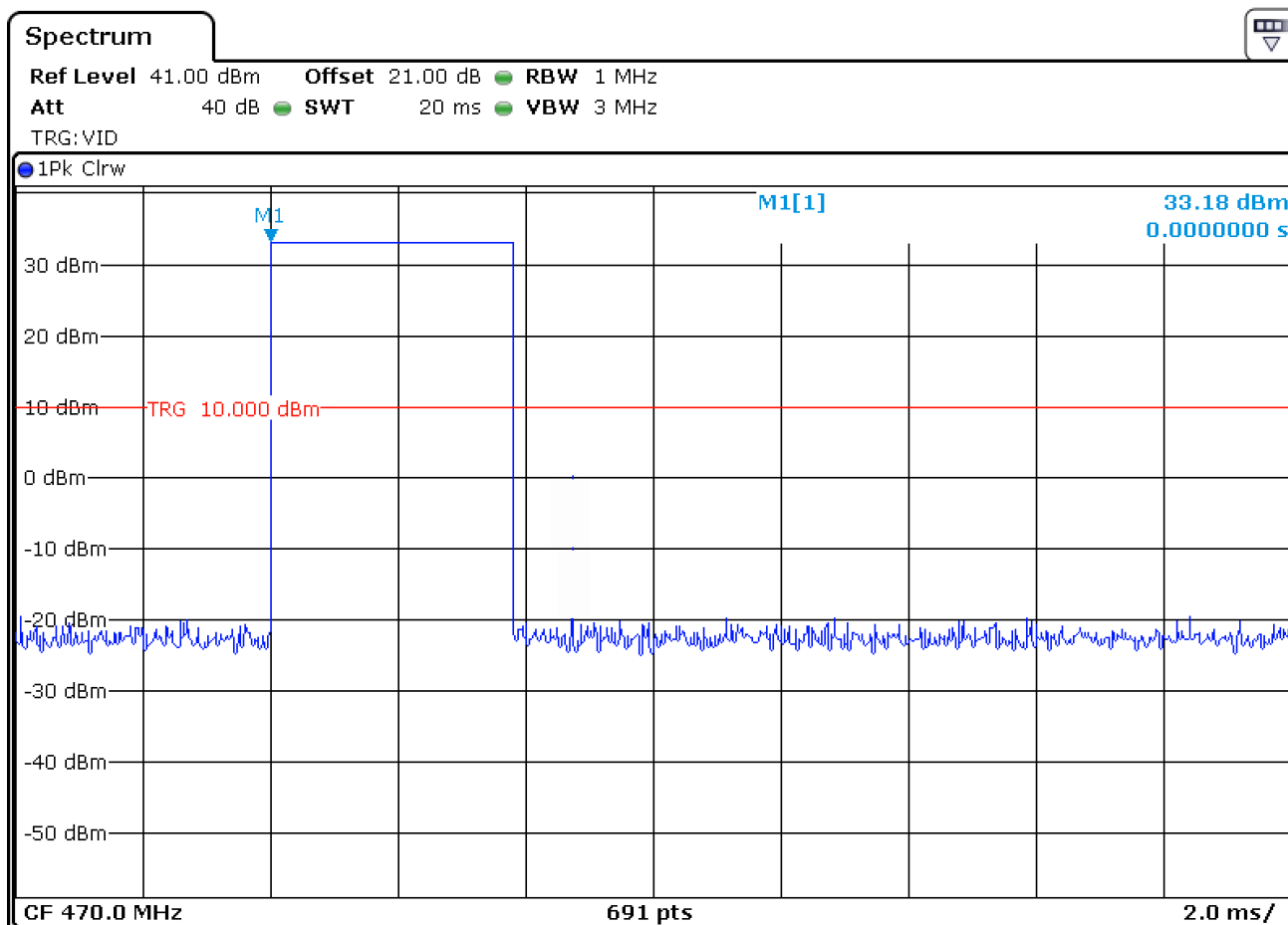

Table 3.2.4 Conducted Spurious Emissions (Frequency 470 MHz)

Frequency, MHz	Output Power, dBm	Gen. Output, dBm	Difference, dBc	Limit, dBc	Result (Pass, Fail, N/A)
470	33.18	-	-	-	-
940	- 42.25	- 42.48	- 75.66	- 60	Pass
1410	- 70.48	- 70.95	- 104.13	- 60	Pass
1880	- 72.04	- 72.83	- 106.01	- 60	Pass
2350	-	-	-	- 60	Pass
2820	-	-	-	- 60	Pass
3290	-	-	-	- 60	Pass
3760	-	-	-	- 60	Pass
4230	-	-	-	- 60	Pass
4700	-	-	-	- 60	Pass

3.3 Radiated Spurious Emissions

3.3.1 Test requirements 90.210 (e)

Except as indicated elsewhere in this part, transmitters used in the radio services governed by this part must comply with the emission masks outlined in this section. Unless otherwise stated, per paragraphs (d)(4), (e)(4), and (m) of this section, measurements of emission power can be expressed in either peak or average values provided that emission powers are expressed with the same parameters used to specify the unmodulated transmitter carrier power. For transmitters that do not produce a full power unmodulated carrier, reference to the unmodulated transmitter carrier power refers to the total power contained in the channel bandwidth. Unless indicated elsewhere in this part, the table in this section specifies the emission masks for equipment operating in the frequency bands governed under this part.

Frequency band (MHz)	Mask for equipment with Audio low pass filter	Mask for equipment without audio low pass filter
Below 25 ¹	A or B	A or C
25-50	B	C
72-76	B	C
150-174 ²	B, D, or E	C, D, or E
150 Paging-only	B	C
220-222	F	F
421-512 ²	B, D, or E	C, D, or E
450 Paging-only	B	G
806-809/851-854	B	H
809-824/854-869 ³	B	G
896-901/935-940	I	J
902-928	K	K
929-930	B	G
4940-4990 MHz	L or M	L or M.
5850-5925 ⁴		
All other bands	B	C

² Equipment designed to operate with a 25 kHz channel bandwidth must meet the requirements of Emission Mask B or C, as applicable. Equipment designed to operate with a 12.5 kHz channel bandwidth must meet the requirements of Emission Mask D, and equipment designed to operate with a 6.25 kHz channel bandwidth must meet the requirements of Emission Mask E.

(e) Emission Mask E—6.25 kHz or less channel bandwidth equipment. For transmitters designed to operate with a 6.25 kHz or less bandwidth, any emission must be attenuated below the power (P) of the highest emission contained within the authorized bandwidth as follows:

(1) On any frequency from the center of the authorized bandwidth f_0 to 3.0 kHz removed from f_0 : Zero dB.

(2) On any frequency removed from the center of the authorized bandwidth by a displacement frequency (f_d in kHz) of more than 3.0 kHz but no more than 4.6 kHz: At least $30 + 16.67(f_d - 3 \text{ kHz})$ or $55 + 10 \log (P)$ or 65 dB, whichever is the lesser attenuation.

(3) On any frequency removed from the center of the authorized bandwidth by more than 4.6 kHz: At least $55 + 10 \log (P)$ or 65 dB, whichever is the lesser attenuation.

(4) The reference level for showing compliance with the emission mask shall be established using a resolution bandwidth sufficiently wide (usually two to three times the channel bandwidth) to capture the true peak emission of the equipment under test. In order to show compliance with the emissions mask up to and including 50 kHz removed from the edge of the authorized bandwidth, adjust the resolution bandwidth to 100 Hz with the measuring instrument in a peak hold mode. A sufficient

number of sweeps must be measured to insure that the emission profile is developed. If video filtering is used, its bandwidth must not be less than the instrument resolution bandwidth. For emissions beyond 50 kHz from the edge of the authorized bandwidth, see paragraph (m) of this section. If it can be shown that use of the above instrumentation settings do not accurately represent the true interference potential of the equipment under test, then an alternate procedure may be used provided prior Commission approval is obtained.

3.3.2 Test procedure

The procedure used was ANSI/TIA-603-D:2010. Substitution antenna with RF signal generator was used.

The transmitter was set up to the normal operational mode with maximum output power and connected to standard transmitter load.

- 1) The spurious emissions were observed in the band of +50 kHz from the edge of the authorized bandwidth to frequency equal 10 times the carrier frequency.
- 2) The transmitter to be tested was placed on the turntable in the test site compliant with ANSI C63.4-2001 clause 5.4.
- 3) Measurement antenna was placed at the distance of 3m away from the EUT with vertical polarization.
- 4) The spurious emissions were observed in the band of +50 kHz from the edge of the authorized bandwidth to the tenth harmonic of the carrier.

The spectrum analyzer was adjusted for the following settings:

Resolution Bandwidth = 10 kHz for spurious emission below 1 GHz, and 1 MHz for spurious emission above 1 GHz.

Video Bandwidth = 300 kHz for spurious emission below 1 GHz, and 3 MHz for spurious emission above 1 GHz.

Sweep Speed slow enough to maintain measurement calibration.

Detector Mode = Positive Peak.

- 5) The height of measurement antenna was changed from 1m to 4m in 10 cm steps to obtain maximum result on the spectrum analyzer.
- 6) The turntable was rotated around its axis to obtain maximum result on the spectrum analyzer.
- 7) Highest possible readings of the spectrum analyzer were recorded.
- 8) Measurements were repeated for horizontal polarization of measurement antenna.
- 9) The transmitter was replaced with a substitution antenna connected to RF signal generator.
- 10) The power into a reference ideal half-wave dipole antenna is calculated by reducing the reading from RF signal generator by the power loss in the cable between the generator and the substitution antenna, and further corrected for the gain of the substitution antenna used relative to an ideal half-wave dipole antenna:

$$P_d \text{ (dBm)} = P_g \text{ (dBm)} - \text{cable loss (dB)} + \text{antenna gain (dB)},$$

where:

P_d is the dipole equivalent power,

P_g is the generator output power into the substitution antenna.

- 11) Radiated spurious emissions (dB) = TX power (dBm) - P_d (dBm).

3.3.3 Test setup layout

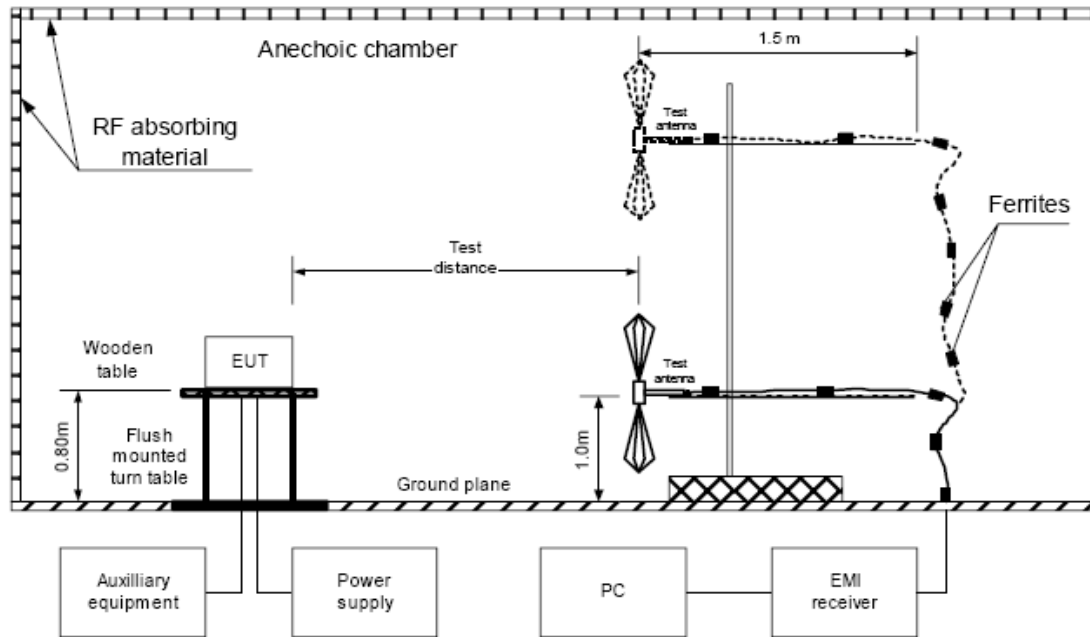

3.3.4 Test result

Temperature: +20 °C

Relative humidity: 68 %

Table 3.3.1 Radiated Spurious Emissions (Frequency 470 MHz, vertical polarization):

F, MHz	Gen. Output, dBm	Coax Loss, dB	Ant. Gain, dBi	Ant. Gain, dBd	Dipole Eq. Power, dBm	Difference, dBc	Limit, dBc	Test result (Pass, Fail, N/A)
470	-37,0	1,9	0,84	-1,31	33,79			
940	- 24,00	3,8	- 6,89	- 9,04	- 36,84	- 70,63	- 60	Pass
1410	- 43,00	4,5	4,80	2,65	- 44,85	- 78,64	- 60	Pass
1880	- 38,00	6,7	5,00	2,85	- 41,85	- 75,64	- 60	Pass
2350	- 47,00	10,1	5,50	3,35	- 53,75	- 87,54	- 60	Pass
2820	- 57,00	11,5	6,50	4,35	- 64,15	- 97,94	- 60	Pass
3290	- 40,00	9,8	7,20	5,05	- 44,75	- 78,54	- 60	Pass
3760	- 52,00	10,1	7,7	5,55	- 56,55	- 90,34	- 60	Pass
4230	- 54,00	9,8	7,60	5,45	- 55,35	- 89,14	- 60	Pass
4700	- 51,00	10,7	7,70	5,55	- 56,15	-89,94	- 60	Pass

Table 3.3.2 Radiated Spurious Emissions (Frequency 460 MHz, vertical polarization):

F, MHz	Gen. Output, dBm	Coax Loss, dB	Ant. Gain, dBi	Ant. Gain, dBd	Dipole Eq. Power, dBm	Difference, dBc	Limit, dBc	Test result (Pass, Fail, N/A)
460	33,35	1,9	0,84	-1,31	30,14			
920	- 21,00	3,8	- 6,58	- 8,73	- 33,53	- 63,67	- 60	Pass
1380	- 42,00	4,2	4,60	2,45	-43,75	- 73,89	- 60	Pass
1840	- 49,00	6,5	4,00	1,85	-53,65	- 83,79	- 60	Pass
2300	- 48,00	9,7	4,50	2,35	-55,35	- 85,49	- 60	Pass
2760	- 54,00	12,4	5,60	3,45	-62,95	- 95,09	- 60	Pass
3220	- 38,00	9,4	7,50	5,35	-42,05	- 72,19	- 60	Pass
3680	-47,00	10,5	7,70	5,55	- 51,95	- 82,09	- 60	Pass
4140	- 50,00	9,5	7,50	5,35	- 54,15	- 84,29	- 60	Pass
4600	- 53,00	10,5	7,30	5,15	- 58,35	- 88,49	- 60	Pass

Table 3.3.3 Radiated Spurious Emissions (Frequency 450 MHz, vertical polarization):

F, MHz	Gen. Output, dBm	Coax Loss, dB	Ant. Gain, dBi	Ant. Gain, dBd	Dipole Eq. Power, dBm	Difference, dBc	Limit, dBc	Test result (Pass, Fail, N/A)
450	31,7	1,9	0,84	-1,31	28,49			
900	- 30,00	3,8	- 6,58	- 8,73	- 42,53	- 71,02	- 60	Pass
1350	- 30,50	4,2	4,50	2,35	- 32,35	- 60,84	- 60	Pass
1800	- 60,00	6,5	5,50	3,35	- 63,15	- 91,64	- 60	Pass
2250	- 51,00	9,7	5,40	3,25	- 57,45	- 85,94	- 60	Pass
2700	- 43,00	12,4	6,24	4,09	- 54,31	- 79,80	- 60	Pass
3150	- 44,00	9,4	7,10	4,95	- 48,45	- 76,94	- 60	Pass
3600	- 60,00	10,5	7,50	5,35	- 65,15	- 93,64	- 60	Pass
4050	- 54,00	9,7	7,90	5,75	- 57,75	- 86,24	- 60	Pass
4500	- 51,00	10,5	7,30	5,15	- 56,35	- 84,84	- 60	Pass

3.4 Conducted Emission

3.4.1 Test requirements of 15.207

(a) Except as shown in paragraphs (b) and (c) of this section, for an intentional radiator that is designed to be connected to the public utility (AC) power line, the radio frequency voltage that is conducted back onto the AC power line on any frequency or frequencies, within the band 150 kHz to 30 MHz, shall not exceed the limits in the following table, as measured using a 50 μ H/50 ohms line impedance stabilization network (LISN). Compliance with the provisions of this paragraph shall be based on the measurement of the radio frequency voltage between each power line and ground at the power terminal. The lower limit applies at the boundary between the frequency ranges.

Frequency of emission (MHz)	Conducted limit (dB μ V)	
	Quasi-peak	Average
0.15-0.5	66 to 56*	56 to 46*
0.5-5	56	46
5-30	60	50

*Decreases with the logarithm of the frequency.

3.4.2 Test procedure (ANSI C63.10-2013, Sections 6.3)

The EUT emitted one transmission every 30 minutes. Maximum transmission time (duration) does not exceed 150 mSec.

The EUT was placed on a platform of nominal size 1 m by 1.5 m, raised 80 cm above the reference ground plane. The vertical conducting plane or wall of an RF-shielded (screened) room shall be located 40 cm to the rear of the EUT. All other surfaces of tabletop or floor-standing EUTs shall be at least 80 cm from any other grounded conducting surface, including the case or cases of one or more LISNs.

The measurements were performed on the line under test in a 2m x 2m x 2m screened enclosure by means of an Impedance Stabilization Network (ISN) bonded to the ground plane and connected to the spectrum analyzer. The EUT was placed on a non-metallic table, 0.8m above the ground reference plane and was configured, arranged and operated in a manner consistent with typical application and load conditions. Normal performance of the EUT was verified.

Conducted common mode (asymmetric mode) disturbance at the tested port was investigated in the appropriate frequency range using the resolution-bandwidth per CISPR16-1, Table 7, and QP and Average readings were taken.

Worst-case results were recorded.

3.4.3 Test result

Temperature: +20°C

Relative humidity: 63%

EUT OPERATING MODE: Transmit

Table 3.4.1 Conducted emission test result**"Phase" (450 MHz, QP detector)**

Frequency, MHz	Measured Result, dB μ V	Limit, dB μ V	Margin, dB	Result (Pass, Fail, N/A)
	QP	QP	QP	
0.17591	40.8	64.6	23.8	Pass
0.40937	44.6	57.7	13.1	Pass
0.95265	44.0	56.0	12.0	Pass
1.59908	44.5	56.0	11.5	Pass
3.63332	42.7	56.0	13.3	Pass
4.39903	37.2	56.0	18.8	Pass
8.52278	22.2	60.0	37.8	Pass
25.39066	26.6	60.0	33.4	Pass

"Phase" (450 MHz, AV detector)

Frequency, MHz	Measured Result, dB μ V	Limit, dB μ V	Margin, dB	Result (Pass, Fail, N/A)
	AV	AV	AV	
0.23623	37.6	52.2	14.6	Pass
0.41265	40.7	47.6	6.9	Pass
0.59061	34.7	46.0	11.3	Pass
1.59908	32.8	46.0	13.2	Pass
3.66239	33.7	46.0	12.3	Pass
4.36412	29.0	46.0	17.0	Pass
7.99644	17.6	50.0	32.4	Pass
28.16183	20.1	50.0	29.9	Pass

"Neutral" (450 MHz, QP detector)

Frequency, MHz	Measured Result, dB μ V	Limit, dB μ V	Margin, dB	Result (Pass, Fail, N/A)
	QP	QP	QP	
0.15486	38.1	65.7	27.6	Pass
0.41928	45.2	57.5	12.3	Pass
0.96027	49.1	56.0	6.9	Pass
1.50032	40.8	56.0	15.2	Pass
3.54750	45.8	56.0	10.2	Pass
4.22721	36.1	56.0	19.9	Pass
8.59096	22.8	60.0	37.2	Pass
25.59378	26.6	60.0	33.4	Pass

"Neutral" (450 MHz, AV detector)

Frequency, MHz	Measured Result, dB μ V	Limit, dB μ V	Margin, dB	Result (Pass, Fail, N/A)
	AV	AV	AV	
0.23812	36.1	52.2	16.1	Pass
0.41928	39.9	47.5	7.6	Pass
0.83862	36.9	46.0	9.1	Pass
1.13518	32.1	46.0	13.9	Pass
3.66239	35.3	46.0	10.7	Pass
4.36412	29.1	46.0	16.9	Pass
7.99644	17.9	50.0	32.1	Pass
28.16183	20.5	50.0	29.5	Pass

"Phase" (460 MHz, QP detector)

Frequency, MHz	Measured Result, dB μ V	Limit, dB μ V	Margin, dB	Result (Pass, Fail, N/A)
	QP	QP	QP	
0.15860	38.5	65.5	27.0	Pass
0.40290	33.0	57.8	24.8	Pass
1.08219	45.4	56.0	10.6	Pass
1.50032	44.5	56.0	11.5	Pass
4.02987	36.8	56.0	19.2	Pass
4.43422	44.8	56.0	11.2	Pass
7.99644	21.5	60.0	38.5	Pass
29.07388	21.3	60.0	38.7	Pass

"Phase" (460 MHz, AV detector)

Frequency, MHz	Measured Result, dB μ V	Limit, dB μ V	Margin, dB	Result (Pass, Fail, N/A)
	AV	AV	AV	
0.24003	35.5	52.1	16.6	Pass
0.41928	38.7	47.5	8.8	Pass
0.72080	34.4	46.0	11.6	Pass
1.20030	29.4	46.0	16.6	Pass
4.02987	25.6	46.0	20.4	Pass
4.39903	37.1	46.0	8.9	Pass
7.99644	16.1	50.0	33.9	Pass
29.99999	16.5	50.0	33.5	Pass

"Neutral" (460 MHz, QP detector)

Frequency, MHz	Measured Result, dB μ V	Limit, dB μ V	Margin, dB	Result (Pass, Fail, N/A)
	QP	QP	QP	
0.15610	37.9	65.6	27.7	Pass
0.42263	42.2	57.4	15.2	Pass
1.08219	48.4	56.0	7.6	Pass
1.50032	45.8	56.0	10.2	Pass
4.09461	43.0	56.0	13.0	Pass
4.39903	45.0	56.0	11.0	Pass
8.06041	25.3	60.0	34.7	Pass
29.99999	22.9	60.0	37.1	Pass

"Neutral" (460 MHz, AV detector)

Frequency, MHz	Measured Result, dB μ V	Limit, dB μ V	Margin, dB	Result (Pass, Fail, N/A)
	AV	AV	AV	
0.24003	34.0	52.1	18.1	Pass
0.42263	38.3	47.4	9.1	Pass
0.72080	36.4	46.0	9.6	Pass
1.14427	33.6	46.0	12.4	Pass
4.09461	27.3	46.0	18.7	Pass
4.22721	32.3	46.0	13.7	Pass
8.12490	18.5	50.0	31.5	Pass
21.30798	14.4	50.0	35.6	Pass

"Phase" (470 MHz, QP detector)

Frequency, MHz	Measured Result, dB μ V	Limit, dB μ V	Margin, dB	Result (Pass, Fail, N/A)
	QP	QP	QP	
0.18161	41.6	64.4	22.8	Pass
0.42263	41.4	57.4	16.0	Pass
1.09085	43.7	56.0	12.3	Pass
1.51233	46.1	56.0	9.9	Pass
4.09461	38.1	56.0	17.9	Pass
4.39903	45.1	56.0	10.9	Pass
7.99644	22.5	60.0	37.5	Pass
29.99999	19.7	60.0	40.3	Pass

"Phase" (470 MHz, AV detector)

Frequency, MHz	Measured Result, dB μ V	Limit, dB μ V	Margin, dB	Result (Pass, Fail, N/A)
	AV	AV	AV	
0.24195	33.9	52.0	18.1	Pass
0.42263	39.0	47.4	8.4	Pass
0.72657	34.5	46.0	11.5	Pass
1.14427	31.4	46.0	14.6	Pass
3.93468	27.9	46.0	18.1	Pass
4.39903	32.3	46.0	13.7	Pass
7.99644	17.2	50.0	32.8	Pass
29.99999	14.2	50.0	35.8	Pass

"Neutral" (470 MHz, QP detector)

Frequency, MHz	Measured Result, dB μ V	Limit, dB μ V	Margin, dB	Result (Pass, Fail, N/A)
	QP	QP	QP	
0.15120	42.1	66.0	23.9	Pass
0.42263	44.3	57.4	13.1	Pass
1.08219	44.5	56.0	11.5	Pass
1.51233	44.9	56.0	11.1	Pass
4.06211	37.9	56.0	18.1	Pass
4.46970	44.9	56.0	11.1	Pass
7.99644	23.2	60.0	36.8	Pass
29.77725	21.1	60.0	38.9	Pass

"Neutral" (470 MHz, AV detector)

Frequency, MHz	Measured Result, dB μ V	Limit, dB μ V	Margin, dB	Result (Pass, Fail, N/A)
	AV	AV	AV	
0.18161	34.9	54.4	19.5	Pass
0.42263	39.5	47.4	7.9	Pass
0.72657	32.6	46.0	13.4	Pass
1.14427	31.1	46.0	14.9	Pass
3.87247	28.2	46.0	17.8	Pass
4.29512	32.8	46.0	13.2	Pass
7.99644	18.0	50.0	32.0	Pass
29.99999	15.0	50.0	35.0	Pass

Plot "Phase" (450 MHz)

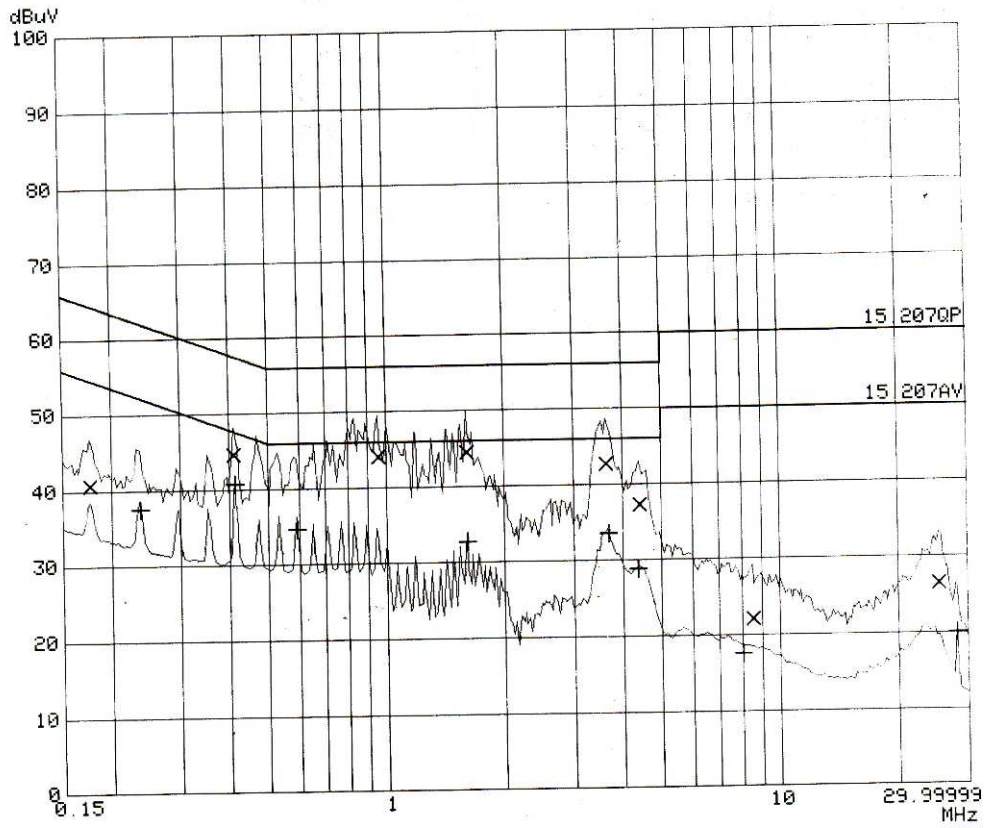

Plot "Neutral" (450 MHz)

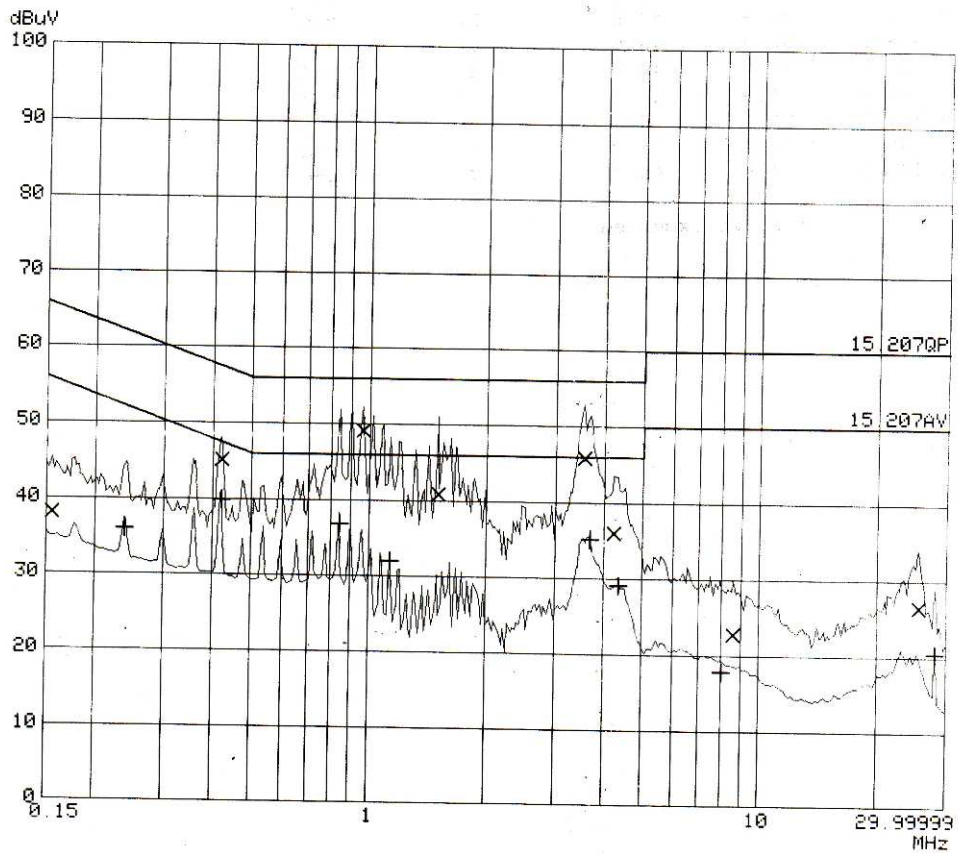

Plot "Phase" (460 MHz)

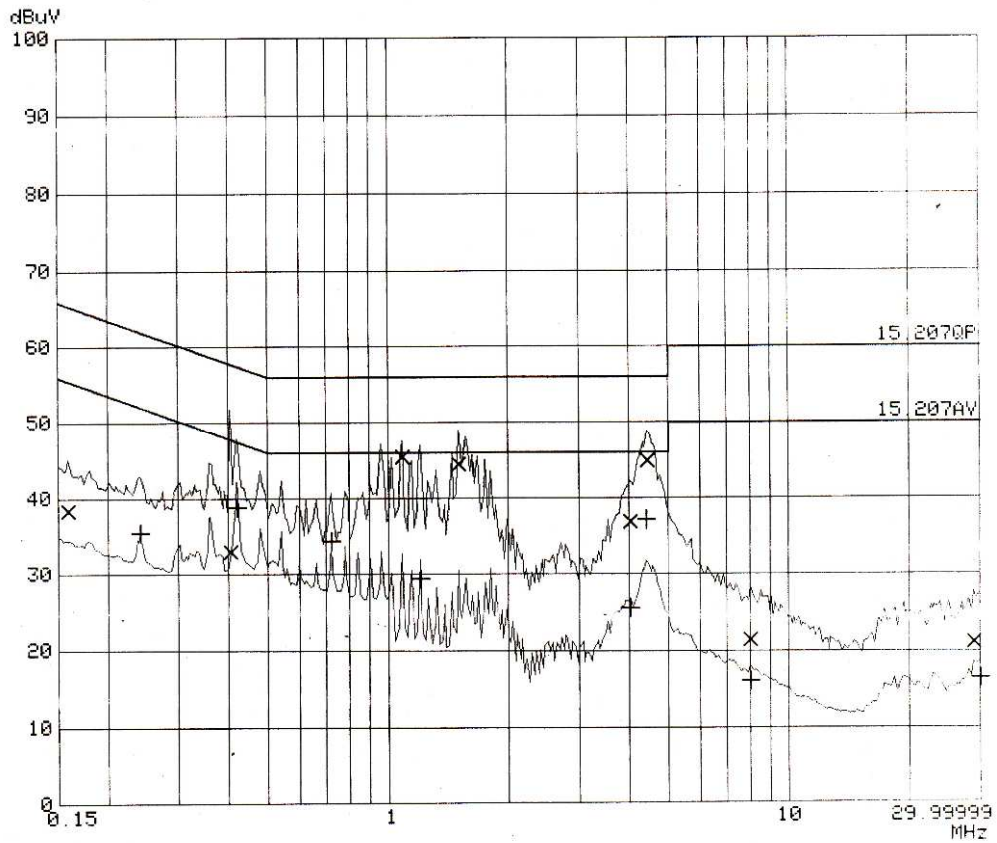

Plot "Neutral" (460 MHz)

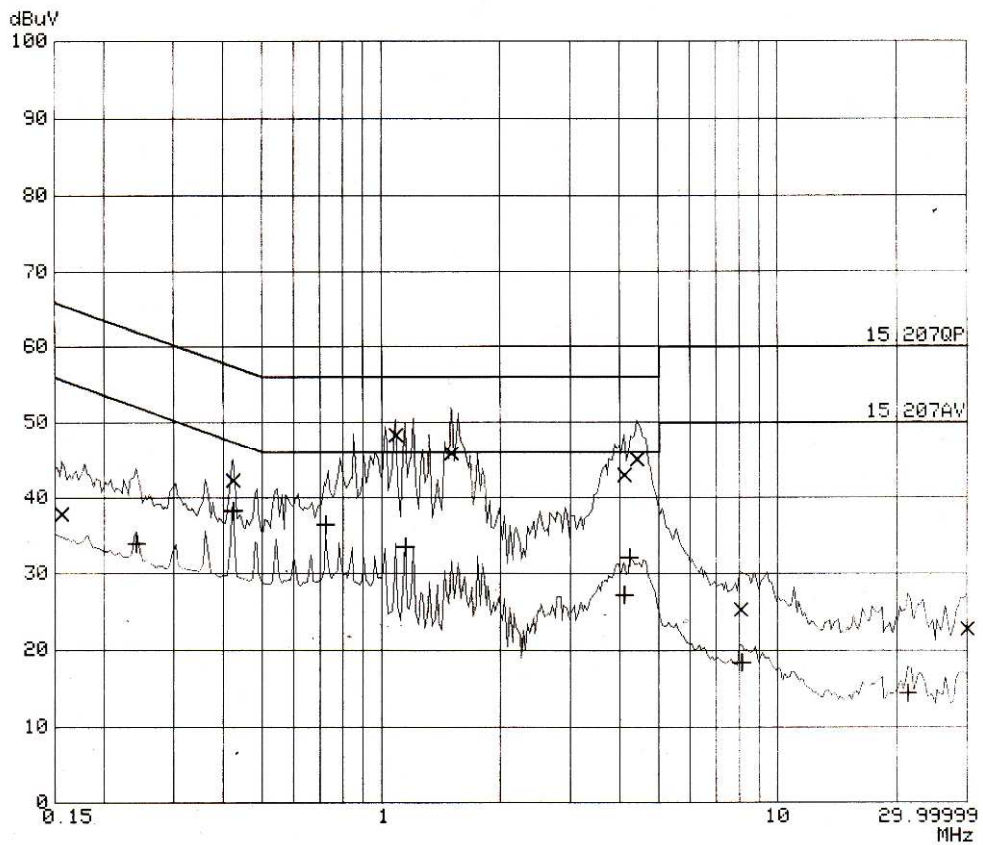

Plot "Phase" (470 MHz)

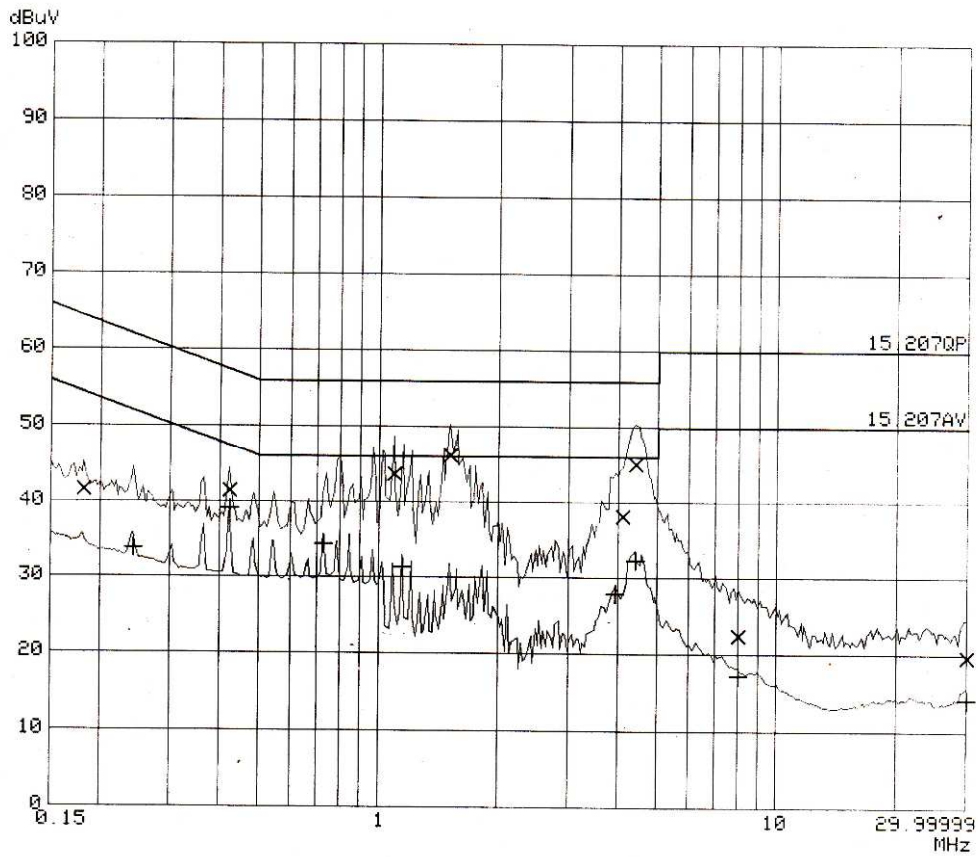

Plot "Neutral" (470 MHz)

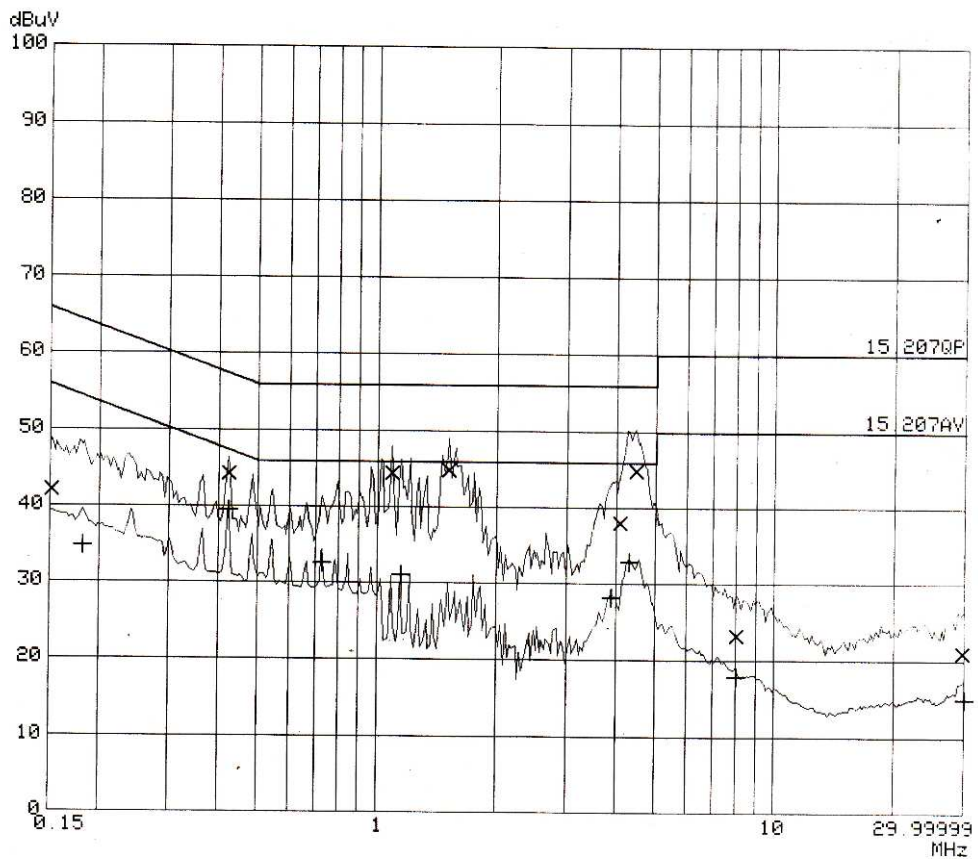

3.5 Conducted Emissions

3.5.1 Test requirements of 15.107

(a) Except for Class A digital devices, for equipment that is designed to be connected to the public utility (AC) power line, the radio frequency voltage that is conducted back onto the AC power line on any frequency or frequencies within the band 150 kHz to 30 MHz shall not exceed the limits in the following table, as measured using a 50 μ H/50 ohms line impedance stabilization network (LISN). Compliance with the provisions of this paragraph shall be based on the measurement of the radio frequency voltage between each power line and ground at the power terminal. The lower limit applies at the band edges.

Frequency of emission (MHz)	Conducted limit (dB μ V)	
	Quasi-peak	Average
0.15-0.5	66 to 56*	56 to 46*
0.5-5	56	46
5-30	60	50

*Decreases with the logarithm of the frequency.

3.5.2 Test procedure (ANSI C63.10-2013, Sections 6.3)

The EUT was placed on a platform of nominal size 1 m by 1.5 m, raised 80 cm above the reference ground plane. The vertical conducting plane or wall of an RF-shielded (screened) room shall be located 40 cm to the rear of the EUT. All other surfaces of tabletop or floor-standing EUTs shall be at least 80 cm from any other grounded conducting surface, including the case or cases of one or more LISNs.

The measurements were performed on the line under test in a 2m x 2m x 2m screened enclosure by means of an Impedance Stabilization Network (ISN) bonded to the ground plane and connected to the spectrum analyzer. The EUT was placed on a non-metallic table, 0.8m above the ground reference plane and was configured, arranged and operated in a manner consistent with typical application and load conditions. Normal performance of the EUT was verified.

Conducted common mode (asymmetric mode) disturbance at the tested port was investigated in the appropriate frequency range using the resolution-bandwidth per CISPR16-1, Table 7, and QP and Average readings were taken.

Worst-case results were recorded.

3.5.3 Test result

Temperature: +20°C

Relative humidity: 63%

EUT OPERATING MODE: Idle

Table 3.5.1 Conducted emission test result**"Phase" (QP detector)**

Frequency, MHz	Measured Result, dB μ V	Limit, dB μ V	Margin, dB	Result (Pass, Fail, N/A)
	QP	QP	QP	
0.15549	43.7	65.7	22.0	Pass
0.42351	45.9	57.4	11.5	Pass
0.82682	48.1	56.0	7.9	Pass
1.57941	43.5	56.0	12.5	Pass
3.52611	43.5	56.0	12.5	Pass
5.73902	38.8	60.0	21.2	Pass
8.67931	22.2	60.0	37.8	Pass
26.59642	27.9	60.0	32.1	Pass

"Phase" (AV detector)

Frequency, MHz	Measured Result, dB μ V	Limit, dB μ V	Margin, dB	Result (Pass, Fail, N/A)
	AV	AV	AV	
0.25678	36.2	51.5	15.3	Pass
0.47284	32.9	46.5	13.6	Pass
0.61735	30.3	46.0	15.7	Pass
1.68312	20.3	46.0	25.7	Pass
2.58405	18.3	46.0	27.7	Pass
5.73902	15.6	50.0	34.4	Pass
7.98731	14.4	50.0	35.6	Pass
28.68230	20.4	50.0	29.6	Pass

"Neutral" (QP detector)

Frequency, MHz	Measured Result, dB μ V	Limit, dB μ V	Margin, dB	Result (Pass, Fail, N/A)
	QP	QP	QP	
0.15474	37.2	65.7	28.5	Pass
0.41839	44.6	57.5	12.9	Pass
0.96147	48.7	56.0	7.3	Pass
1.50218	40.5	56.0	15.5	Pass
3.54826	44.9	56.0	11.1	Pass
4.22935	35.5	56.0	20.5	Pass
8.59351	21.9	60.0	38.1	Pass
25.62735	26.5	60.0	33.5	Pass

"Neutral" (AV detector)

Frequency, MHz	Measured Result, dB μ V	Limit, dB μ V	Margin, dB	Result (Pass, Fail, N/A)
	AV	AV	AV	
0.19895	36.2	53.7	17.5	Pass
0.41363	32.1	47.6	15.5	Pass
0.61290	29.4	46.0	16.6	Pass
1.13754	21.0	46.0	25.0	Pass
2.56478	18.6	46.0	27.4	Pass
6.94535	15.1	50.0	34.9	Pass
15.47853	13.6	50.0	36.4	Pass
19.54227	22.0	50.0	28.0	Pass

Plot 3.5.1 "Phase"

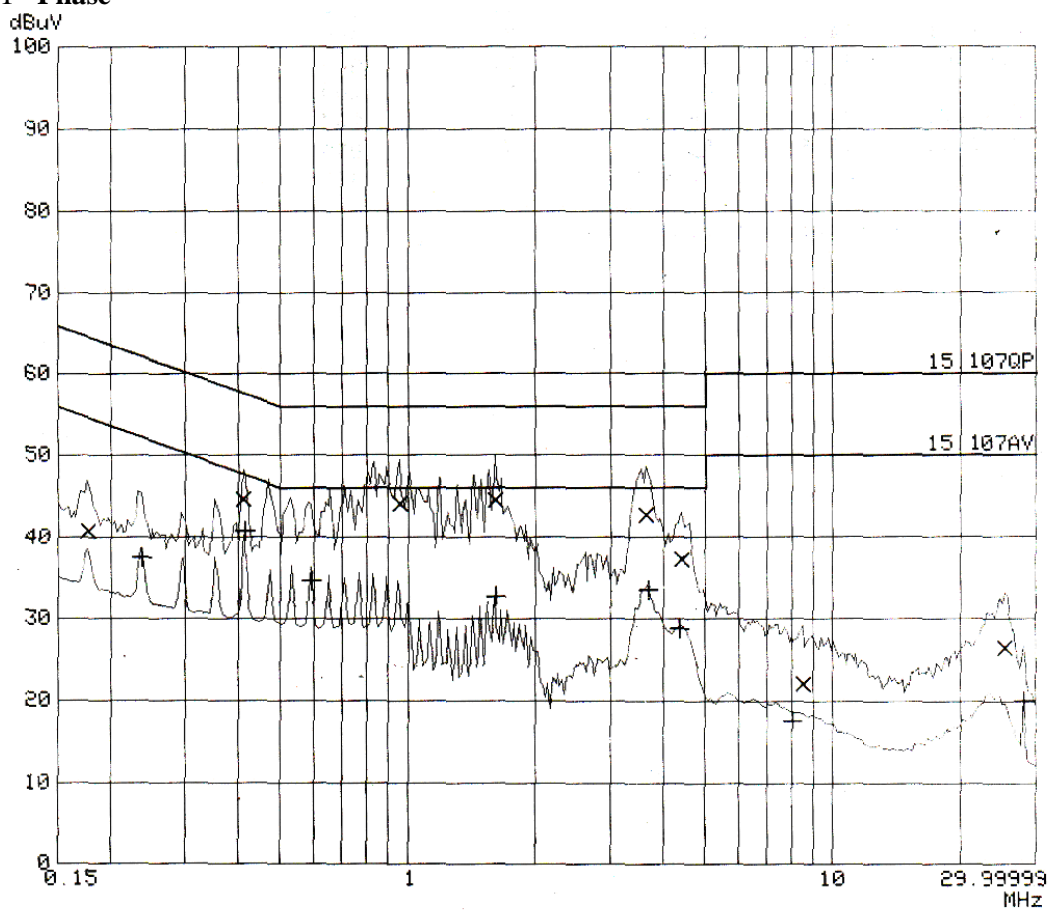

Plot 3.5.2 "Neutral"

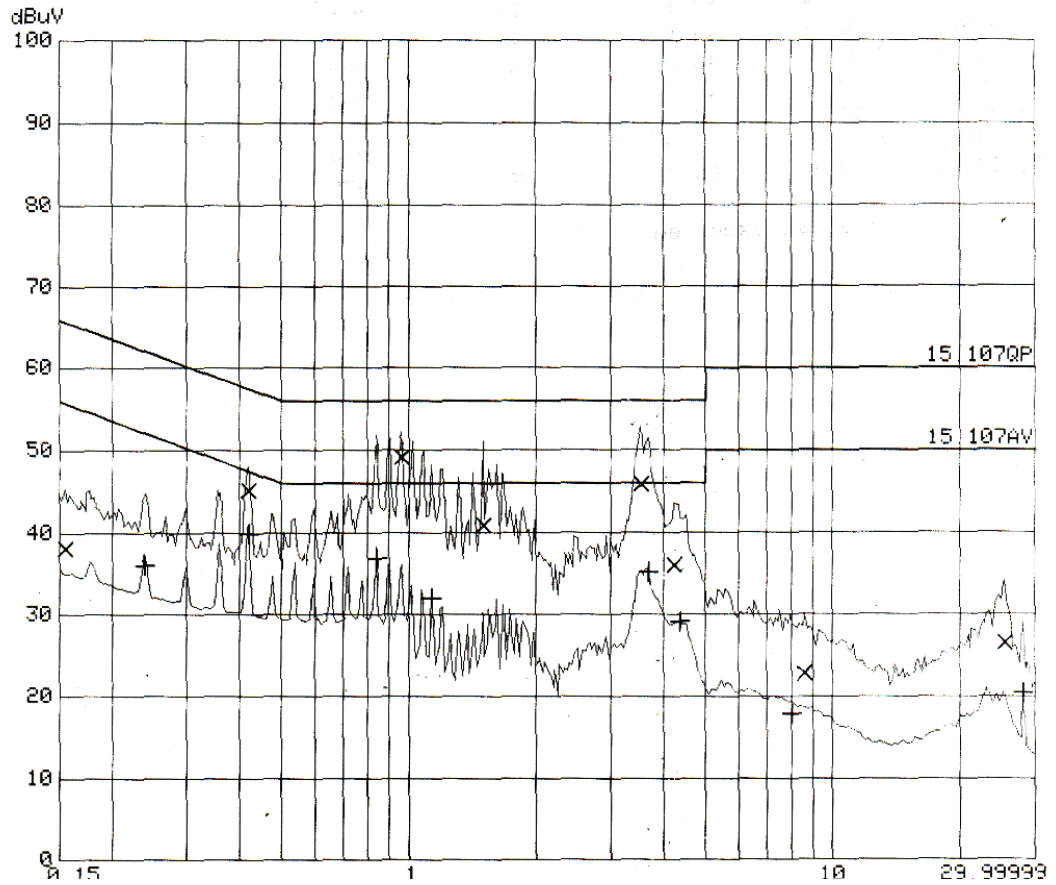

3.6 Radiated Emission

3.6.1 Test requirements 15.109 Class B

Frequency of emission (MHz)	Field strength (microvolts/meter)	Field Strength (dB μ V/m)
30-88	100	40
88-216	150	43.5
216-960	200	46
Above 960	500	54

3.6.2 Test procedure (ANSI C63.4, Sections 11.6 and 12.1.4)

The test was performed to measure radiated emissions from the equipment under test enclosure. The measurement was made in the anechoic chamber at measurement distance of 3m in two bands: (30-1000) MHz, (1000-10000) MHz.

- 1) The equipment under test was set to stand-by mode.
- 2) In the band of (30-1000) MHz the measurement was made in anechoic chamber with metal floor. The turntable was rotated, the antenna height was altered in the range of 1m - 4m, the polarization of biconical antenna was changed from horizontal to vertical in a process of seeking for the maximum result. Settings of the test receiver: RBW = 120 kHz; Video Detector = Positive Peak during prequalification measurement, Quasi-Peak - during final measurement.
- 3) In the band of (1000-10000) MHz the measurement was made in fully anechoic chamber. The height of test antenna was fixed while the turntable was rotated and the polarization of horn test antenna was changed from horizontal to vertical in a process of seeking for the maximum result. Settings of the test receiver: RBW = 1000 kHz; Video Detector = Positive Peak during prequalification measurement, Average - during final measurement.
- 4) The worst test results (the lowest margins) were recorded and shown in the associated plots.

Figure 3.10.1 Test setup layout (above 30 MHz and below 10 GHz)

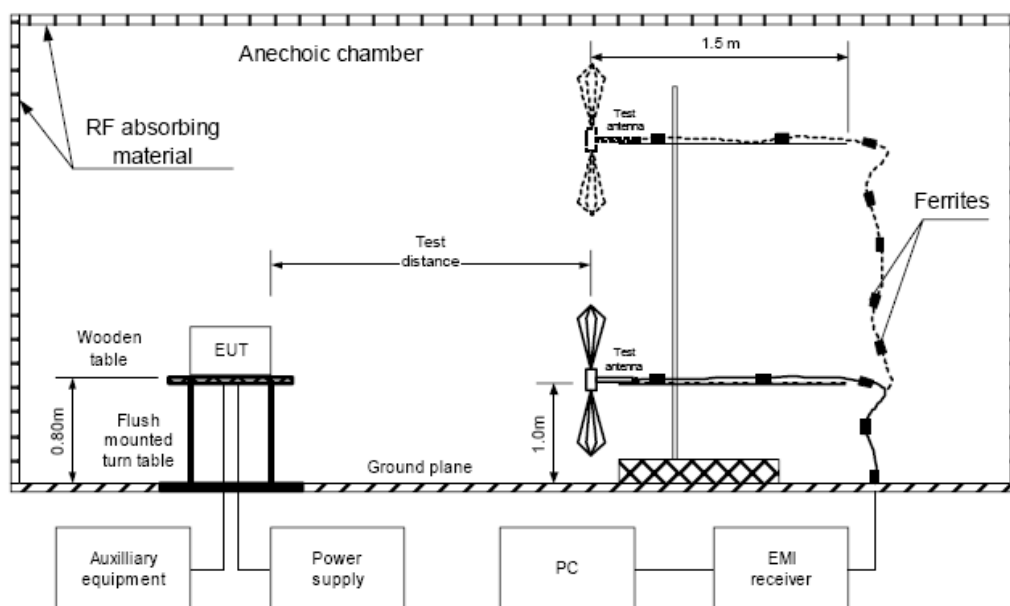

3.6.3 Test result

Temperature: +18 °C

Relative humidity: 56 %

EUT OPERATING MODE: Receive / Stand-by

Table 3.6.2 Radiated emission test result (450 MHz)

Frequency, MHz	Turntable position, degrees	Antenna height, m	Antenna polarization	Peak detector emission, dB μ V/m	Quasi-Peak Detector Emission, dB μ V/m	Average detector emission, dB μ V/m	Limit, dB μ V/m	Result (Pass, Fail, N/A)
43.066722	0	1.0	H	18.3	15.3	-	40.0	Pass
45.122990	90	1.0	H	17.6	14.8	-	40.0	Pass
68.235604	0	1.0	V	20.5	16.0	-	40.0	Pass
109.648685	180	1.0	V	22.9	22.7	-	43.5	Pass
125.912440	180	1.0	V	18.2	13.7	-	43.5	Pass
211.442604	90	3.5	V	18.1	14.4	-	43.5	Pass
358.541227	180	3.0	H	23.8	18.8	-	46.0	Pass
497.047087	90	3.5	H	27.0	22.4	-	46.0	Pass
685.929477	90	2.5	H	30.3	25.6	-	46.0	Pass
947.942732	270	1.0	V	33.9	29.6	-	46.0	Pass
1142.927837	90	2.0	V	36.3	-	24.0	54.0	Pass
1337.384077	90	2.5	V	37.2	-	25.1	54.0	Pass
1906.448617	0	3.5	H	38.4	-	28.4	54.0	Pass
2447.681309	0	3.5	V	41.7	-	30.6	54.0	Pass
3153.165336	0	2.5	V	41.0	-	31.6	54.0	Pass
3928.889623	0	2.5	V	47.1	-	33.5	54.0	Pass
4960.527616	90	3.0	H	48.0	-	36.1	54.0	Pass
6341.101393	180	1.5	H	46.9	-	37.2	54.0	Pass
7853.944804	0	2.5	V	50.6	-	40.2	54.0	Pass
9721.616384	90	2.0	V	54.1	-	42.1	54.0	Pass

Table 3.6.3 Radiated emission test result (460 MHz)

Frequency, MHz	Turntable position, degrees	Antenna height, m	Antenna polarization	Peak detector emission, dB μ V/m	Quasi-Peak Detector Emission, dB μ V/m	Average detector emission, dB μ V/m	Limit, dB μ V/m	Result (Pass, Fail, N/A)
40.831409	180	3.0	V	17.0	14.2	-	40.0	Pass
56.661272	90	2.5	V	18.4	11.3	-	40.0	Pass
60.952829	90	4.0	H	17.5	14.7	-	40.0	Pass
103.740402	90	1.5	V	21.5	13.9	-	43.5	Pass
105.309817	180	2.0	H	25.3	23.0	-	43.5	Pass
127.176788	180	3.0	V	18.3	13.1	-	43.5	Pass
208.954506	270	3.5	H	20.2	13.0	-	43.5	Pass
335.812216	90	2.0	V	23.2	16.1	-	46.0	Pass
426.814244	90	1.0	V	26.6	20.1	-	46.0	Pass
658.883048	90	4.0	V	29.0	25.0	-	46.0	Pass
955.532445	0	1.5	H	32.3	27.2	-	46.0	Pass
1149.521310	0	3.5	H	35.3	-	20.0	54.0	Pass
1552.347341	90	3.5	H	36.8	-	22.5	54.0	Pass
1948.304336	180	4.0	H	39.6	-	26.7	54.0	Pass
2485.275826	0	2.5	H	41.2	-	26.8	54.0	Pass

Frequency, MHz	Turntable position, degrees	Antenna height, m	Antenna polarization	Peak detector emission, dB μ V/m	Quasi-Peak Detector Emission, dB μ V/m	Average detector emission, dB μ V/m	Limit, dB μ V/m	Result (Pass, Fail, N/A)
3077.758890	90	1.0	H	42.6	-	28.5	54.0	Pass
3749.086933	0	2.5	H	43.3	-	30.7	54.0	Pass
4853.912675	90	2.5	V	48.8	-	34.9	54.0	Pass
6509.277071	180	2.5	V	47.4	-	36.2	54.0	Pass
7711.302967	90	2.0	H	50.0	-	37.1	54.0	Pass
9539.969889	90	1.0	V	53.4	-	40.8	54.0	Pass

Table 3.6.4 Radiated emission test result (470 MHz)

Frequency, MHz	Turntable position, degrees	Antenna height, m	Antenna polarization	Peak detector emission, dB μ V/m	Quasi-Peak Detector Emission, dB μ V/m	Average detector emission, dB μ V/m	Limit, dB μ V/m	Result (Pass, Fail, N/A)
45.716635	0	4.0	V	19.3	13.2	-	40.0	Pass
59.776619	90	3.0	H	19.8	12.6	-	40.0	Pass
64.673707	270	4.0	V	17.5	12.5	-	40.0	Pass
104.219663	0	1.0	H	21.0	14.9	-	43.5	Pass
107.611169	90	1.0	V	25.3	20.1	-	43.5	Pass
123.724263	180	3.0	V	14.9	13.4	-	43.5	Pass
242.909387	90	3.0	H	19.9	11.5	-	46.0	Pass
338.722566	0	2.5	V	20.8	16.0	-	46.0	Pass
476.749917	0	1.0	V	25.1	21.6	-	46.0	Pass
671.944730	90	2.0	V	30.2	24.5	-	46.0	Pass
953.109072	90	3.0	V	32.5	28.6	-	46.0	Pass
1257.754196	0	3.5	V	35.1	-	22.5	54.0	Pass
1563.432577	0	4.0	H	36.5	-	27.6	54.0	Pass
1989.470855	270	3.5	H	40.6	-	29.9	54.0	Pass
2532.308400	0	1.5	V	39.6	-	31.2	54.0	Pass
3194.016456	270	1.0	V	41.7	-	32.3	54.0	Pass
4360.450818	0	2.0	H	43.5	-	36.1	54.0	Pass
4641.296500	0	2.0	V	47.5	-	33.3	54.0	Pass
6407.165935	0	3.0	V	49.8	-	37.5	54.0	Pass
7642.861356	270	1.0	V	51.0	-	38.6	54.0	Pass
9136.462253	90	4.0	H	19.3	-	22.5	54.0	Pass

3.7 Transient stability

3.7.1 Test requirements 90.214

Transmitters designed to operate in the 150-174 MHz and 421-512 MHz frequency bands must maintain transient frequencies within the maximum frequency difference limits during the time intervals indicated:

Table 3.7.1 Limit Transient Frequency Behavior

Time intervals ^{1,2}	Maximum frequency difference ³	All equipment	
		150 to 174 MHz	421 to 512 MHz
Transient Frequency Behavior for Equipment Designed to Operate on 25 kHz Channels			
t_1 ⁴	±25.0 kHz	5.0 ms	10.0 ms
t_2	±12.5 kHz	20.0 ms	25.0 ms
t_3 ⁴	±25.0 kHz	5.0 ms	10.0 ms
Transient Frequency Behavior for Equipment Designed to Operate on 12.5 kHz Channels			
t_1 ⁴	±12.5 kHz	5.0 ms	10.0 ms
t_2	±6.25 kHz	20.0 ms	25.0 ms
t_3 ⁴	±12.5 kHz	5.0 ms	10.0 ms
Transient Frequency Behavior for Equipment Designed to Operate on 6.25 kHz Channels			
t_1 ⁴	±6.25 kHz	5.0 ms	10.0 ms
t_2	±3.125 kHz	20.0 ms	25.0 ms
t_3 ⁴	±6.25 kHz	5.0 ms	10.0 ms

¹ t_{on} is the instant when a 1 kHz test signal is completely suppressed, including any capture time due to phasing.

- t_1 is the time period immediately following t_{on} .
- t_2 is the time period immediately following t_1 .
- t_3 is the time period from the instant when the transmitter is turned off until t_{off} .
- t_{off} is the instant when the 1 kHz test signal starts to rise.

² During the time from the end of t_2 to the beginning of t_3 , the frequency difference must not exceed the limits specified in § 90.213.

³ Difference between the actual transmitter frequency and the assigned transmitter frequency.

⁴ If the transmitter carrier output power rating is 6 watts or less, the frequency difference during this time period may exceed the maximum frequency difference for this time period.

3.7.2 Test procedure

- 1) The transmitter was connected to the universal radio tester CMS54.
- 2) The transmitter was set up to the normal operational mode at mid frequency with maximum output power.
- 3) The transient behavior of transmitter was observed in the moment of keying (TX-off to TX-on) and unkeying (TX-on to TX-off) using the special option of the CMS54 radio tester.

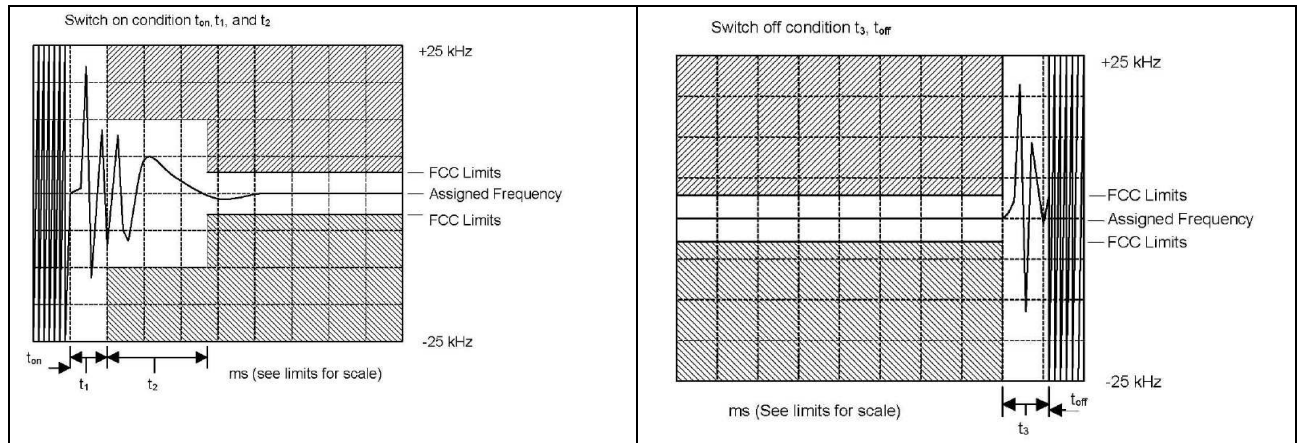

3.7.3 Test setup layout

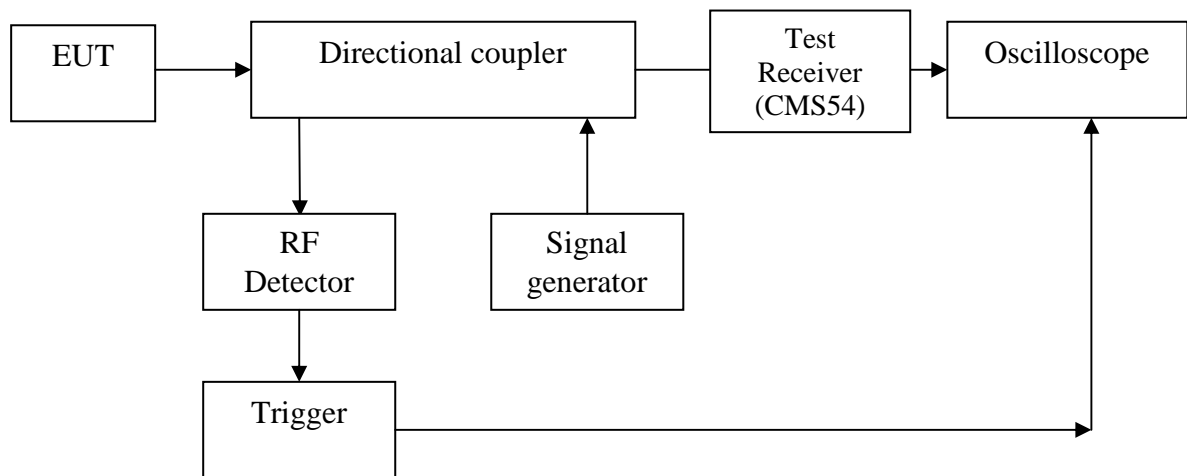

3.7.4 Test result

Temperature: +23 °C

Relative humidity: 47 %

3.7.1 Plot

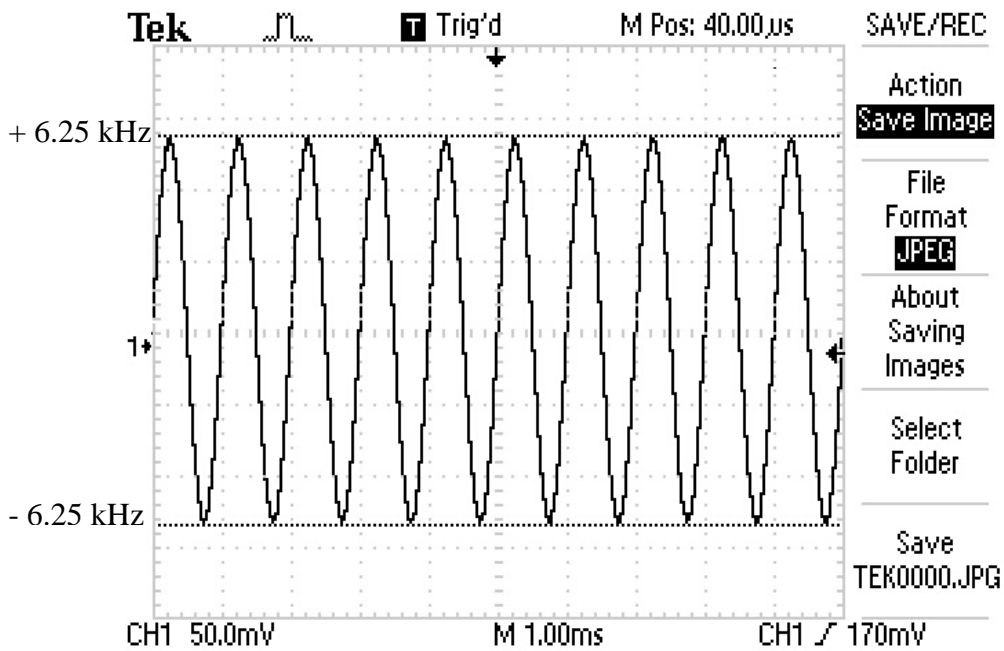

± 6.25 kHz = 342 mV
 ± 3.125 kHz = 171 mV
 ± 230 Hz (±0.5 ppm) = 12,6 mV

3.7.2 Plot: t₁ time period

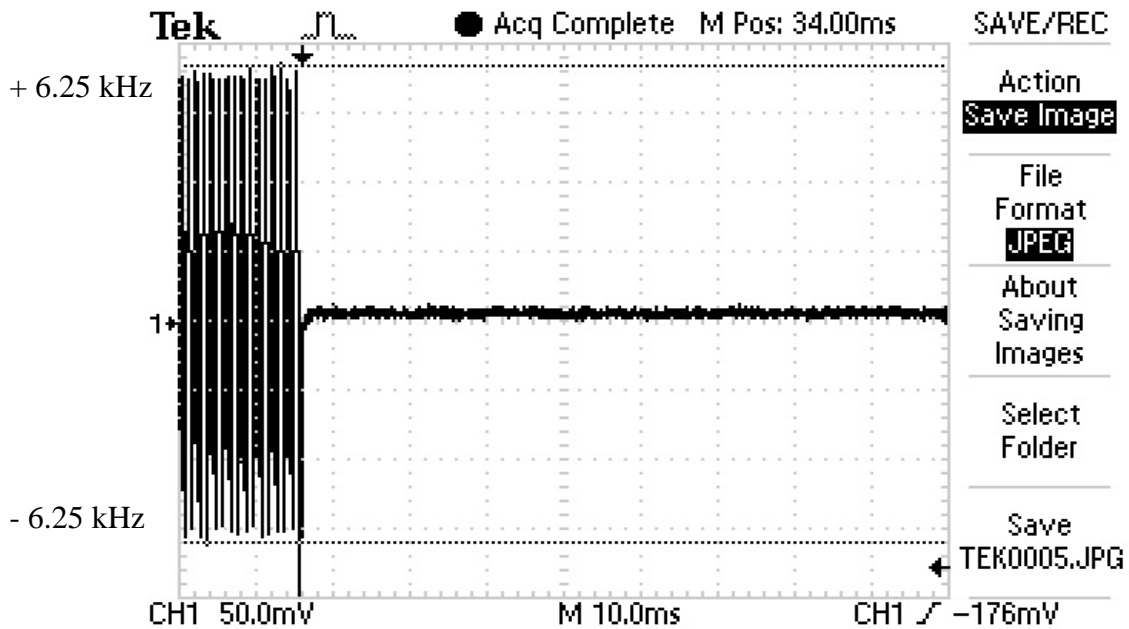

3.7.3 Plot: t_2 time period

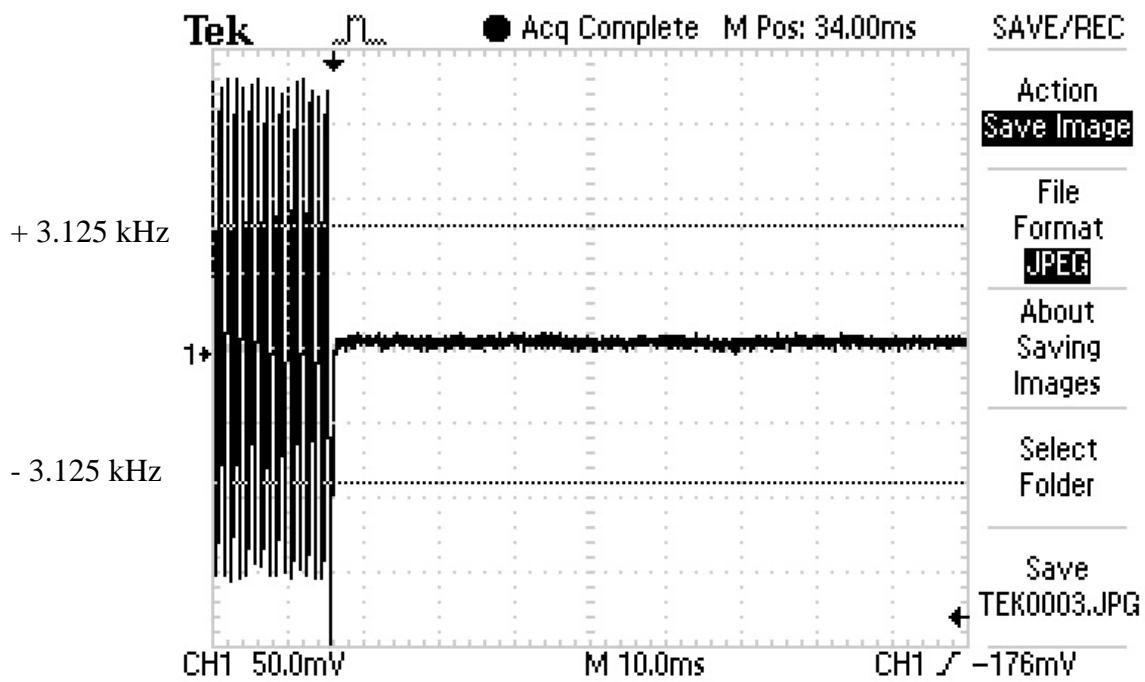

3.7.4 Plot: $t_2 - t_3$ time period

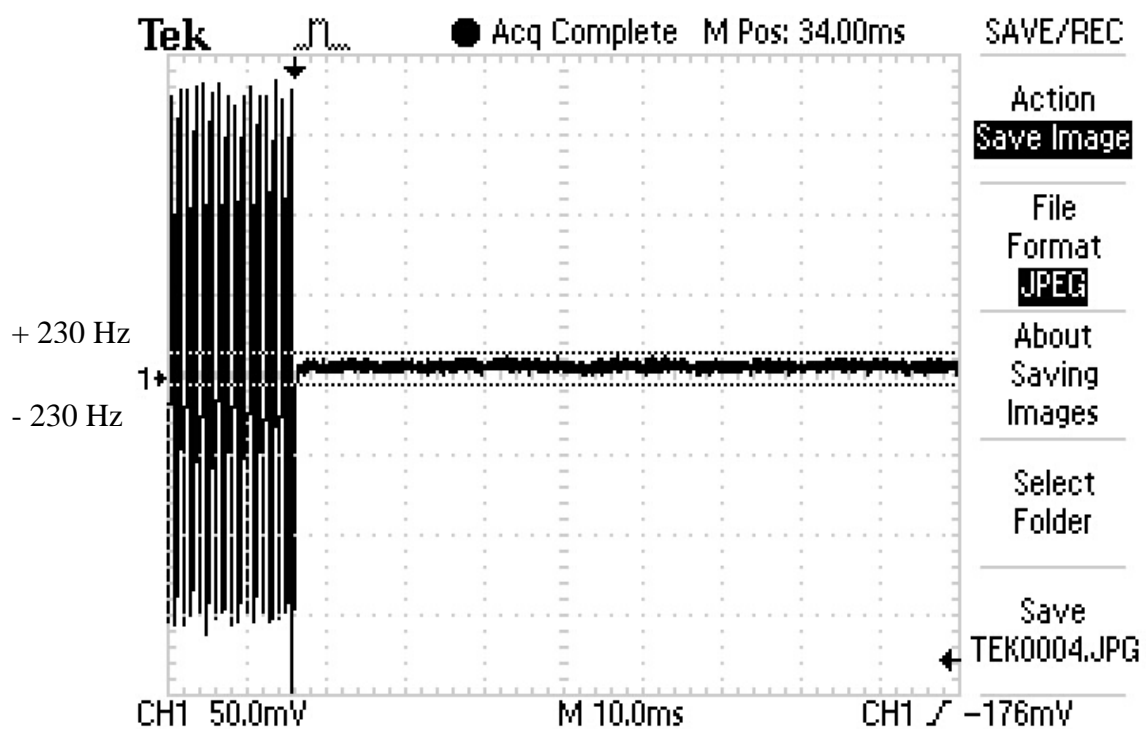

3.7.5 Plot: t_3 time period

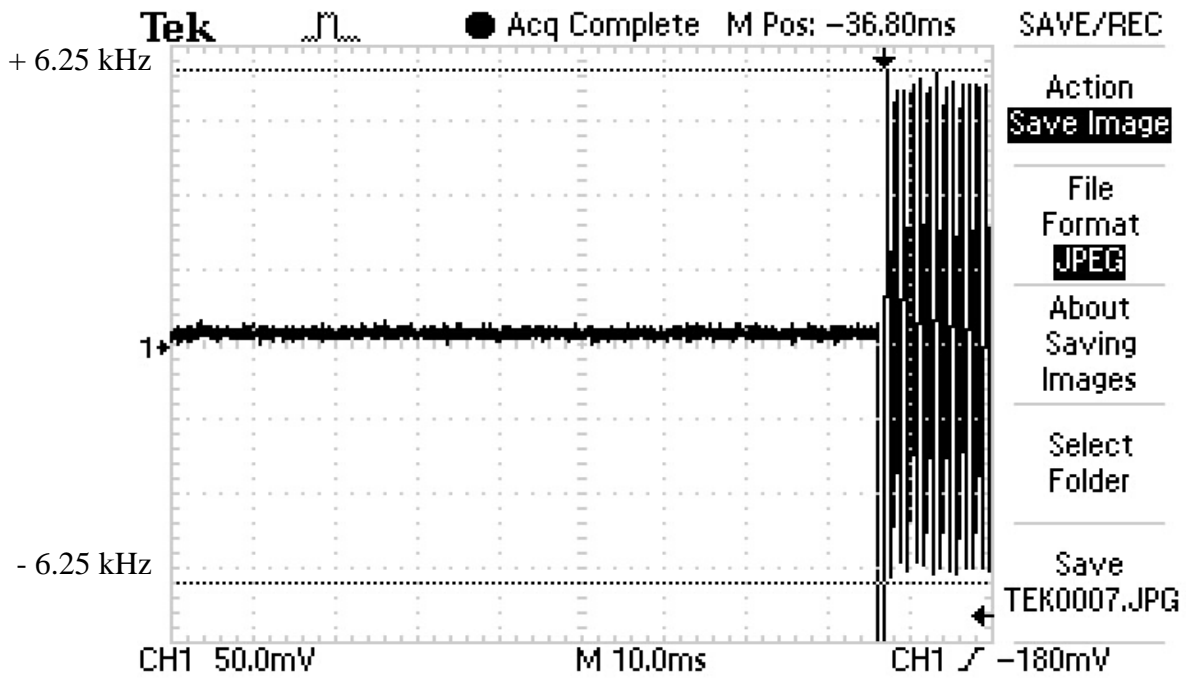

3.8 Frequency stability vs power supply

3.8.1 Test requirements 90.213

(a) Unless noted elsewhere, transmitters used in the services governed by this part must have minimum frequency stability as specified in the following table.

Table 3.8.1 Limit frequency stability vs power supply

Frequency range (MHz)	Fixed and base stations	Mobile stations	
		Over 2 watts output power	2 watts or less output power
Below 25	1,2,3 100	100	200
25-50	20	20	50
72-76	5		50
150-174	5,11 5	6 5	4,6 50
216-220	1.0		1.0
220-222 ¹²	0.1	1.5	1.5
421-512	7,11,14 2.5	8 5	8 5
806-809	¹⁴ 1.0	1.5	1.5
809-824	¹⁴ 1.5	2.5	2.5
851-854	1.0	1.5	1.5
854-869	1.5	2.5	2.5
896-901	¹⁴ 0.1	1.5	1.5
902-928	2.5	2.5	2.5
902-928 ¹³	2.5	2.5	2.5
929-930	1.5		
935-940	0.1	1.5	1.5
1427-1435	⁹ 300	300	300
Above 2450 ¹⁰			

⁷ In the 421-512 MHz band, fixed and base stations with a 12.5 kHz channel bandwidth must have a frequency stability of 1.5 ppm. Fixed and base stations with a 6.25 kHz channel bandwidth must have a frequency stability of 0.5 ppm.

⁸ In the 421-512 MHz band, mobile stations designed to operate with a 12.5 kHz channel bandwidth must have a frequency stability of 2.5 ppm. Mobile stations designed to operate with a 6.25 kHz channel bandwidth must have a frequency stability of 1.0 ppm.

b) For the purpose of determining the frequency stability limits, the power of a transmitter is considered to be the maximum rated output power as specified by the manufacturer.

3.8.2 Test procedure

- 1) The transmitter was set up to the normal operational mode with maximum output power with no modulation signal applied.
- 2) The transmitter was connected to the frequency meter HM8123 for measuring the frequency.
- 3) The supply voltage was changed to observe the frequency stability across the power supply voltage range.

3.8.3 Test setup layout

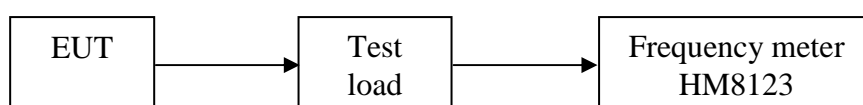

3.8.4 Test result

Temperature: +23 °C

Relative humidity: 47 %

Power Supply voltage, V	Frequency (MHz)	Deviation (Hz)	Deviation (ppm)	Limit, ppm	Result (Pass, Fail, N/A)
242.0	459.999986	- 14	-0.030	0.5	Pass
237.6	459.999986	- 14	-0.030	0.5	Pass
233.2	459.999964	- 36	-0.078	0.5	Pass
228.8	459.999964	- 36	-0.078	0.5	Pass
224.4	459.999957	- 43	-0.093	0.5	Pass
220.0	459.999957	- 43	-0.093	0.5	Pass
215.6	459.999957	- 43	-0.093	0.5	Pass
211.2	459.999962	- 38	-0.082	0.5	Pass
206.8	459.999968	- 32	-0.069	0.5	Pass
202.4	459.999971	- 29	-0.063	0.5	Pass
198.0	459.999971	- 29	-0.063	0.5	Pass

Reference frequency = 460.0 MHz

3.9 Frequency stability vs temperature

3.9.1 Test requirements 90.213

(a) Unless noted elsewhere, transmitters used in the services governed by this part must have a minimum frequency stability as specified in the following table.

Frequency range (MHz)	Fixed and base stations	Mobile stations	
		Over 2 watts output power	2 watts or less output power
Below 25	1,2,3 100	100	200
25-50	20	20	50
72-76	5		50
150-174	5,11 5	6 5	4,6 50
216-220	1.0		1.0
220-222 ¹²	0.1	1.5	1.5
421-512	7,11,14 2.5	8 5	8 5
806-809	14 1.0	1.5	1.5
809-824	14 1.5	2.5	2.5
851-854	1.0	1.5	1.5
854-869	1.5	2.5	2.5
896-901	14 0.1	1.5	1.5
902-928	2.5	2.5	2.5
902-928 ¹³	2.5	2.5	2.5
929-930	1.5		
935-940	0.1	1.5	1.5
1427-1435	9 300	300	300
Above 2450 ¹⁰			

⁷ In the 421-512 MHz band, fixed and base stations with a 12.5 kHz channel bandwidth must have a frequency stability of 1.5 ppm. Fixed and base stations with a 6.25 kHz channel bandwidth must have a frequency stability of 0.5 ppm.

⁸ In the 421-512 MHz band, mobile stations designed to operate with a 12.5 kHz channel bandwidth must have a frequency stability of 2.5 ppm. Mobile stations designed to operate with a 6.25 kHz channel bandwidth must have a frequency stability of 1.0 ppm.

b) For the purpose of determining the frequency stability limits, the power of a transmitter is considered to be the maximum rated output power as specified by the manufacturer.

3.9.2 Test procedure

- 1) The transmitter was set up to the normal operational mode with maximum output power with no modulation signal applied.
- 2) The transmitter was connected to the Frequency meter HM8123 for measuring the frequency.
- 3) The transmitter was placed in the temperature chamber to observe the frequency stability across the temperature range.

3.9.3 Test setup layout

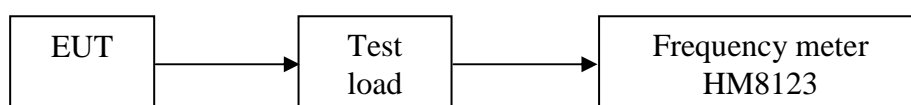

3.9.4 Test result

Temperature: +23 °C

Relative humidity: 47 %

Temperature (°C)	Frequency (MHz)	Deviation (Hz)	Deviation (ppm)	Limit, ppm	Result (Pass, Fail, N/A)
+85	460.000140	140	0.304	0.5	Pass
+80	460.000121	121	0.263	0.5	Pass
+70	460.000087	87	0.189	0.5	Pass
+60	460.000028	28	0.061	0.5	Pass
+50	460.000039	39	0.085	0.5	Pass
+40	459.999973	- 27	- 0.059	0.5	Pass
+30	459.999977	- 23	- 0.050	0.5	Pass
+20	459.999957	- 43	- 0.093	0.5	Pass
+10	459.999970	- 30	- 0.065	0.5	Pass
0	459.999949	- 51	- 0.111	0.5	Pass
- 10	459.999940	- 60	- 0.130	0.5	Pass
- 20	459.999966	- 34	- 0.074	0.5	Pass
- 30	459.999947	- 53	- 0.115	0.5	Pass
- 40	No Transmission	-	-	-	N/A
+20	459.999987	- 13	- 0.028	0.5	Pass

Reference frequency = 460.0 MHz

3.10 99% Occupied Bandwidth

3.10.1 Test Setup

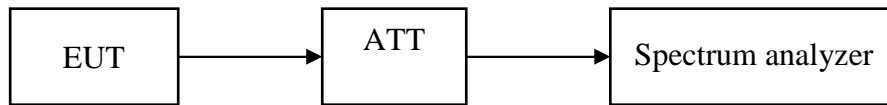

3.10.2 Limit

According to §90.209(b)(5) the maximum occupied bandwidth for a 6.25 kHz channel spacing is 6 kHz.

3.10.3 Test Procedure

The following procedure according to ANSI C63.10-2013 shall be used for measuring 99% power bandwidth.

Settings for the spectrum analyzer:

- center frequency is set to the nominal EUT channel center frequency;
- frequency span for the spectrum analyzer shall be between 1.5 times and 5.0 times the occupied bandwidth (OBW);
- RBW shall be in the range of 1% to 5% of the OBW, and VBW shall be approximately three times the RBW;
- Set the reference level of the instrument as required, keeping the signal from exceeding the maximum input mixer level for linear operation. The peak of the spectral envelope shall be more than $[10 \log (OBW/RBW)]$ below the reference level.
- Peak detection and max hold mode (until the trace stabilizes) shall be used.
- The 99% power bandwidth function of the spectrum analyzer shall be used.

3.10.4 Test Results

Temperature: +25 °C

Relative humidity: 60 %

Channel Frequency, MHz	99% Occupied Bandwidth, kHz	Limit, kHz	Test Result (Pass, Fail, N/A)
450	3.80	6.00	Pass
460	3.85	6.00	Pass
470	3.82	6.00	Pass

Low Channel Plot

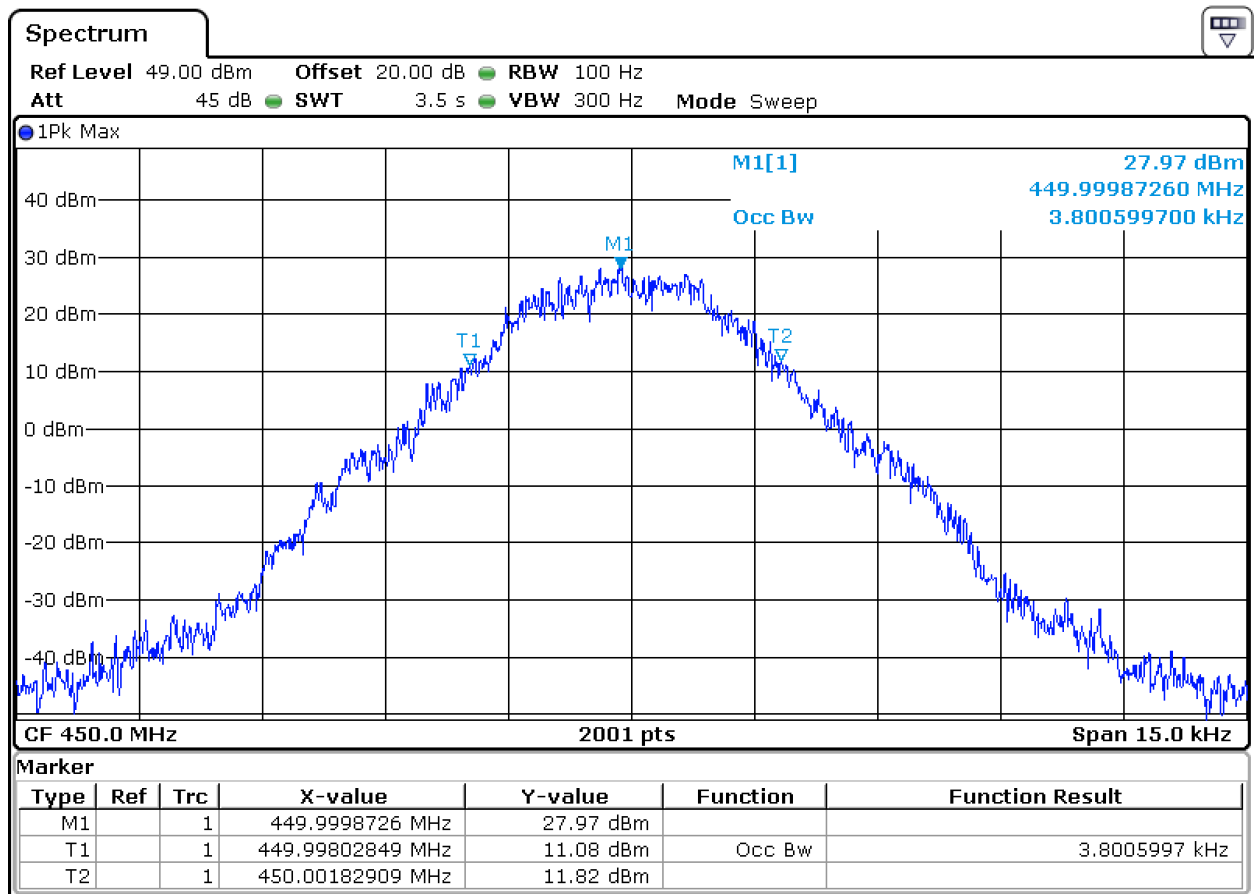

Middle Channel Plot

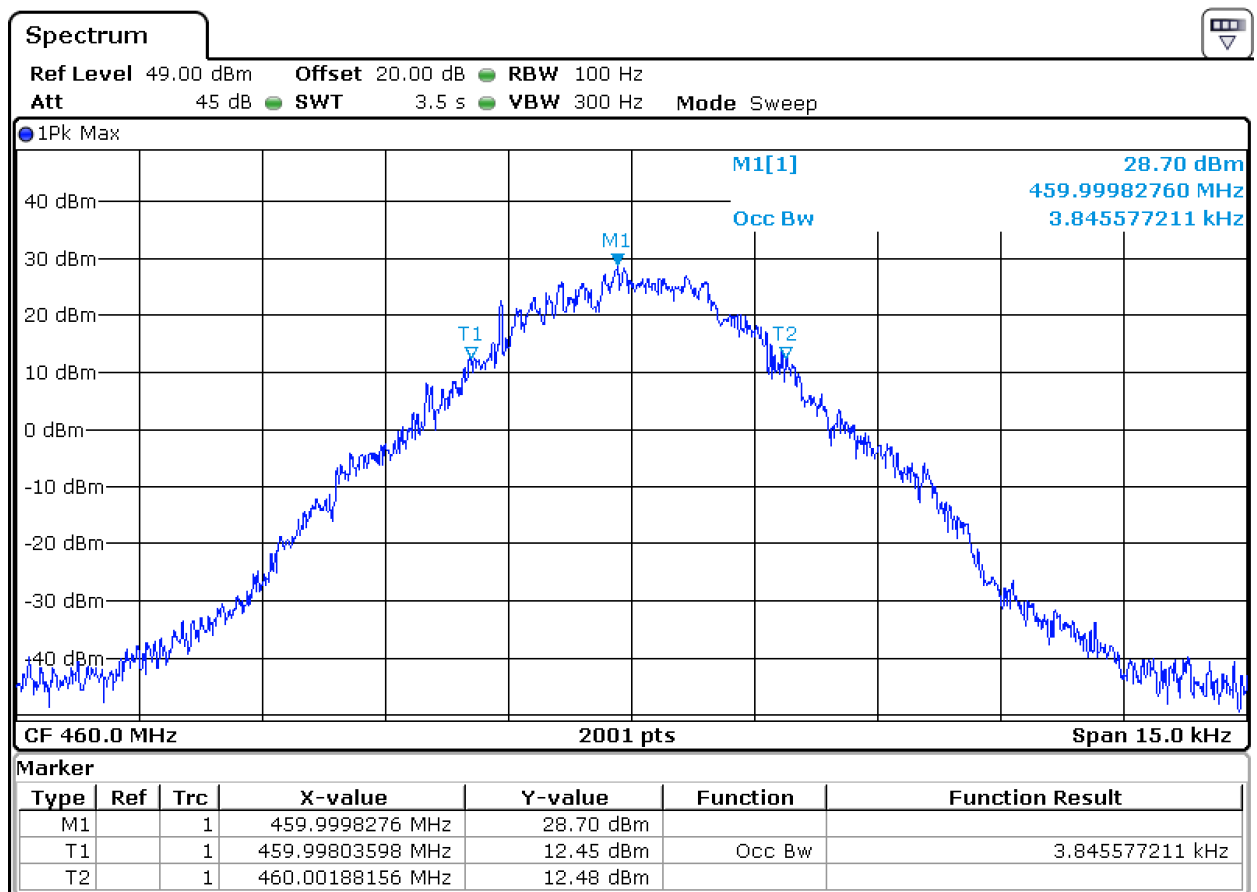

High Channel Plot

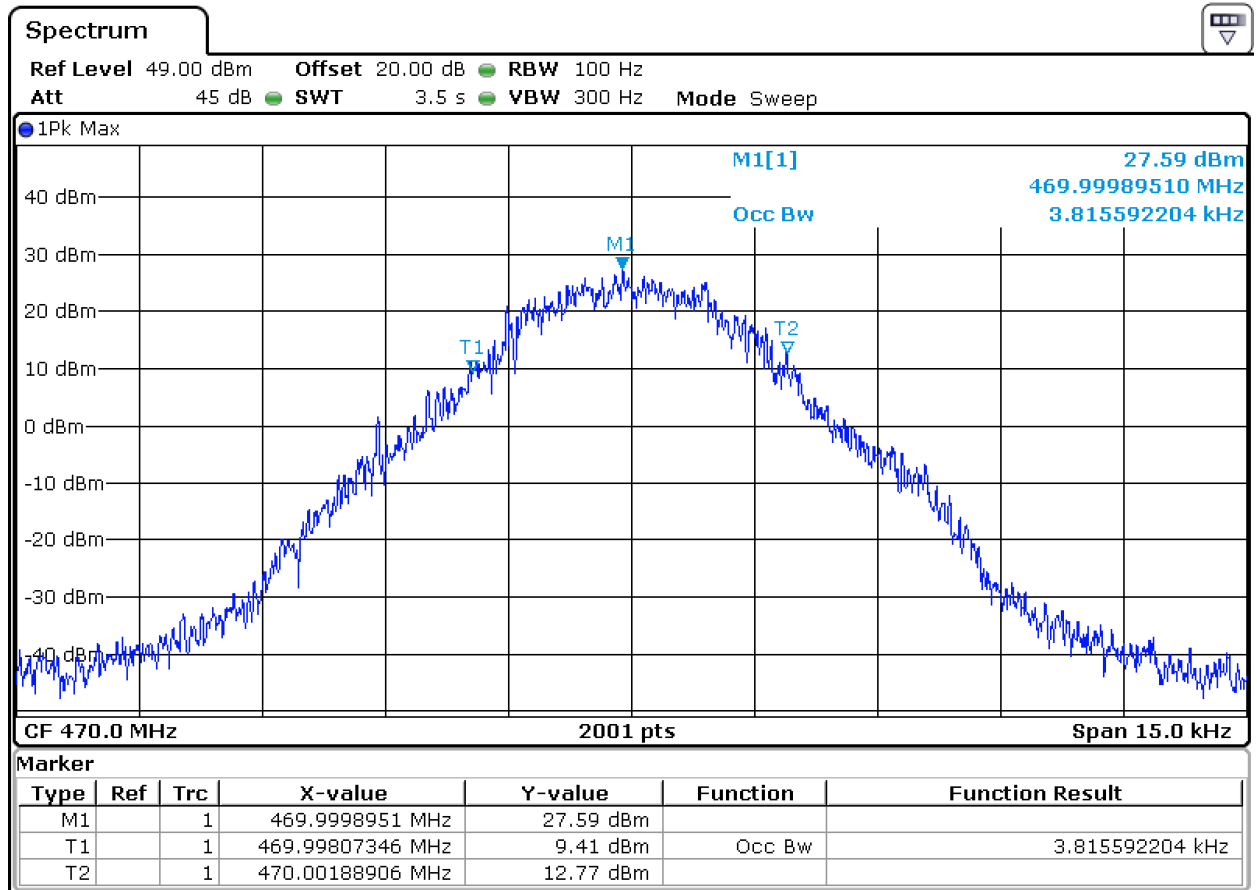

3.11 Operating Frequencies

Assignment and use of the frequencies in the band 450-470 MHz for fixed operations regulates by paragraph 47 CFR Part 90.261 and authorized in an individual license for the radio.