

# FCC Measurement/Technical Report on

## Navigation display module with BT connectivity

J1AB

FCC ID: NT8-J1AB

IC: 3043A-J1AB

**Test Report Reference:** MDE\_VIS\_2017\_FCC\_04

**Test Laboratory:**

7layers GmbH  
Borsigstrasse 11  
40880 Ratingen  
Germany



Deutsche  
Akkreditierungsstelle  
D-PL-12140-01-01  
D-PL-12140-01-02  
D-PL-12140-01-03

**Note:**

The following test results relate only to the devices specified in this document. This report shall not be reproduced in parts without the written approval of the test laboratory.

**7layers GmbH**

Borsigstraße 11  
40880 Ratingen, Germany  
T +49 (0) 2102 749 0  
F +49 (0) 2102 749 350

Geschäftsführer/  
Managing Directors:  
Frank Spiller  
Bernhard Retka  
Alexandre Norré-Oudard

Registergericht/registered:  
Düsseldorf HRB 75554  
USt-Id.-Nr./VAT-No. DE203159652  
Steuer-Nr./TAX-No. 147/5869/0385

a Bureau Veritas  
Group Company

[www.7layers.com](http://www.7layers.com)

## Table of Contents

<b>1</b>	<b>Applied Standards and Test Summary</b>	<b>3</b>
1.1	Applied Standards	3
1.2	FCC-IC Correlation Table	4
1.3	Measurement Summary	5
<b>2</b>	<b>Revision History / Signatures</b>	<b>6</b>
<b>3</b>	<b>Administrative Data</b>	<b>7</b>
3.1	Testing Laboratory	7
3.2	Project Data	7
3.3	Applicant Data	7
3.4	Manufacturer Data	7
<b>4</b>	<b>Test object Data</b>	<b>8</b>
4.1	General EUT Description	8
4.2	EUT Main components	8
4.3	Ancillary Equipment	9
4.4	Auxiliary Equipment	9
4.5	EUT Setups	9
4.6	Operating Modes / Test Channels	9
4.7	Product labelling	10
<b>5</b>	<b>Test Results</b>	<b>11</b>
5.1	Conducted Emissions at AC mains	11
5.2	Radiated Emissions	14
<b>6</b>	<b>Test Equipment</b>	<b>19</b>
<b>7</b>	<b>Antenna Factors, Cable Loss and Sample Calculations</b>	<b>23</b>
7.1	LISN R&S ESH3-Z5 (150 kHz – 30 MHz)	23
7.2	Antenna R&S HFH2-Z2 (9 kHz – 30 MHz)	24
7.3	Antenna R&S HL562 (30 MHz – 1 GHz)	25
7.4	Antenna R&S HF907 (1 GHz – 18 GHz)	26
7.5	Antenna EMCO 3160-09 (18 GHz – 26.5 GHz)	27
7.6	Antenna EMCO 3160-10 (26.5 GHz – 40 GHz)	28
<b>8</b>	<b>Measurement Uncertainties</b>	<b>29</b>
<b>9</b>	<b>Photo Report</b>	<b>30</b>

## 1 APPLIED STANDARDS AND TEST SUMMARY

### 1.1 APPLIED STANDARDS

#### **Applicable FCC Rules**

Prepared in accordance with the requirements of FCC Rules and Regulations as listed in 47 CFR Ch.1 Parts 2 and 15 (10-1-19 Edition). The following subparts are applicable to the results in this test report.

#### **Part 2, Subpart J - Equipment Authorization Procedures, Certification**

#### **Part 15, Subpart B – Unintentional Radiators**

§ 15.107 Conducted limits

§ 15.109 Radiated emission limits; general requirements

#### **Applicable ISED Standards**

ICES-Gen, Issue 1

ICES-003, Issue 6

Note:

ANSI C63.4-2014 is applied.

## 1.2 FCC-IC CORRELATION TABLE

### Correlation of measurement requirements for Information Technology Equipment (ITE) from FCC and IC

Measurement	FCC reference	IC reference
Conducted Emissions (AC Power Line)	§15.107	ICES-003 Issue 6: 6.1
Radiated Spurious Emissions	§15.109	ICES-003 Issue 6: 6.2

#### Remarks:

1. FCC Part 15 subpart B, ICES 003 and CISPR 22 contain different definitions of Class A and Class B limits, i.e. which class is applicable to which kind of EUT.  
ICES 003 and CISPR 22 distinguish between the location where the EUT is intended to operate whilst FCC refers to the method of commercial distribution (distributive trades).
2. The correct assignment of the appropriate class to the concrete EUT is not scope of this test report!
3. A radio apparatus that is specifically subject to an Industry Canada Radio Standard Specification (RSS) and which contains an ITE is not subject to ICES-003 provided the ITE is used only to enable operation of the radio apparatus and the ITE does not control additional functions or capabilities.
4. ISM (Industrial, Scientific or Medical) radio frequency generators, though they may contain ITE, are excluded from the definition of ITE and are not subject to ICES-003. They are instead subject to the Interference-Causing Equipment Standard ICES-001, which specifically addresses ISM radio frequency generators.

### 1.3 MEASUREMENT SUMMARY

**47 CFR CHAPTER I FCC PART 15                      § 15.107 / Class B**  
**Subpart B**

Conducted Emissions at AC mains  
 The measurement was performed according to ANSI C63.4

<b>OP-Mode</b>	<b>Setup</b>	<b>Date</b>	<b>Final Result</b>	
			<b>FCC</b>	<b>IC</b>
AC mains connection, Test setup via auxiliary equipment, stand-alone	S01_AT01	2021-04-01	Passed	Passed

**47 CFR CHAPTER I FCC PART 15                      § 15.109 / Class B**  
**Subpart B**

Radiated Emissions  
 The measurement was performed according to ANSI C63.4

<b>OP-Mode</b>	<b>Setup</b>	<b>Date</b>	<b>Final Result</b>	
			<b>FCC</b>	<b>IC</b>
AC mains connection, Measurement range, Test setup via auxiliary equipment, 1 GHz - 18 GHz, stand-alone	S01_AT01	2021-03-26	Passed	Passed
via auxiliary equipment, 30 MHz - 1 GHz, stand-alone	S01_AT01	2021-03-24	Passed	Passed

N/A: Not applicable  
 N/P: Not performed

## 2 REVISION HISTORY / SIGNATURES

Report version control			
Version	Release date	Change Description	Version validity
initial	2021-06-02	--	valid
--	--	--	--

COMMENT: -



---

(responsible for accreditation scope)  
Dipl.-Ing. Bernhard Retka



---

(responsible for testing and report)  
M.Sc. Joel Asongwe



7 layers GmbH, Borsigstr. 11  
40880 Ratingen, Germany  
Phone +49 (0)2102 749 0

### 3 ADMINISTRATIVE DATA

#### 3.1 TESTING LABORATORY

Company Name: 7layers GmbH  
Address: Borsigstr. 11  
40880 Ratingen  
Germany

The test facility is accredited by the following accreditation organisation:

Laboratory accreditation no: DAkKS D-PL-12140-01-01| -02 | -03  
FCC Designation Number: DE0015  
FCC Test Firm Registration: 929146  
ISED CAB Identifier: DE0007; ISED#: 3699A  
Responsible for accreditation scope: Dipl.-Ing. Bernhard Retka  
Report Template Version: 2021-01-13

#### 3.2 PROJECT DATA

Responsible for testing and report: M.Sc. Joel Asongwe  
Employees who performed the tests: documented internally at 7Layers  
Date of Report: 2021-06-02  
Testing Period: 2021-03-24 to 2021-04-01

#### 3.3 APPLICANT DATA

Company Name: Visteon Corporation  
Address: One Village Center Drive  
Van Buren Township, MI, 48111,  
U.S.A  
Contact Person: Heidi Sepanic, Corporative Secretary

#### 3.4 MANUFACTURER DATA

Company Name: please see Applicant Data  
Address:  
Contact Person:

## 4 TEST OBJECT DATA

### 4.1 GENERAL EUT DESCRIPTION

Kind of Device product description	A 1.49" TFT with TBT (Turn By Turn navigation) and FOTA feature for 2 wheeler products. The module is customized to suit premium variants for Royal Enfield models. The Module syncs up with mobile app developed by Royal Enfield. The app then transmits the TBT information from mobile to display module via Bluetooth. The SW updates or image changes if any, will be uploaded via FOTA.
Product name	Navigation display module with BT connectivity
Type	J1AB
<b>Declared EUT data by the supplier</b>	
Power Supply Type	DC
Nominal Voltage / Frequency	13.5 V
Test Voltage / Frequency	120 V 60 Hz (laboratory power supply) 13.5 V DC (EUT)
Highest internal frequency	2480 MHz
Ports	Cable Harness incl. DC
Special software used for testing	NXP software provided by Applicant

### 4.2 EUT MAIN COMPONENTS

Sample Name	Sample Code	Description
EUT D	DE1105009at01	Radiated Sample
Sample Parameter	Value	
Serial No.	-	
HW Version	PWB25073	
SW Version	V07.05	
Comment	Sample with integral Antenna	

NOTE: The short description is used to simplify the identification of the EUT in this test report.



### 4.3 ANCILLARY EQUIPMENT

For the purposes of this test report, ancillary equipment is defined as equipment which is used in conjunction with the EUT to provide operational and control features to the EUT. It is necessary to configure the system in a typical fashion, as a customer would normally use it. But nevertheless Ancillary Equipment can influence the test results.

Device	Details (Manufacturer, Type Model, OUT Code)	Description
-	-	-

### 4.4 AUXILIARY EQUIPMENT

For the purposes of this test report, auxiliary equipment is defined as equipment which is used temporarily to enable operational and control features especially used for the tests of the EUT which is not used during normal operation or equipment that is used during the tests in combination with the EUT but is not subject of this test report. It is necessary to configure the system in a typical fashion, as a customer would normally use it. But nevertheless Auxiliary Equipment can influence the test results.

Device	Details (Manufacturer, Type Model, HW, SW, S/N)	Description
AUX 1	- , - , - , - , -	USB to TTL Converter
AUX 2	PeakTech 6005D (30 V / 5 A), - , - , 81062045	Laboratory Power supply, providing DC for EUT

### 4.5 EUT SETUPS

This chapter describes the combination of EUTs and equipment used for testing. The rationale for selecting the EUTs, ancillary and auxiliary equipment and interconnecting cables, is to test a representative configuration meeting the requirements of the referenced standards.

Setup	Combination of EUTs	Description and Rationale
S01_AT01	EUT D, AUX 1, AUX 2,	Radiated setup

### 4.6 OPERATING MODES / TEST CHANNELS

This chapter describes the operating modes of the EUTs used for testing.

BT-LE local RX CH19

## 4.7 PRODUCT LABELLING

### 4.7.1 FCC ID LABEL

Please refer to the documentation of the applicant.

### 4.7.2 LOCATION OF THE LABEL ON THE EUT

Please refer to the documentation of the applicant.

## 5 TEST RESULTS

### 5.1 CONDUCTED EMISSIONS AT AC MAINS

Standard **FCC Part 15 Subpart B**

**The test was performed according to:**  
ANSI C63.4

#### 5.1.1 TEST DESCRIPTION

The test set-up was made in accordance to the general provisions of ANSI C 63.4. The Equipment Under Test (EUT) was setup in a shielded room to perform the conducted emissions measurements in a typical installation configuration. The EUT was powered from 50 $\mu$ H || 50 Ohm Line Impedance Stabilization Network (LISN). The LISN's unused connections were terminated with 50 Ohm loads.

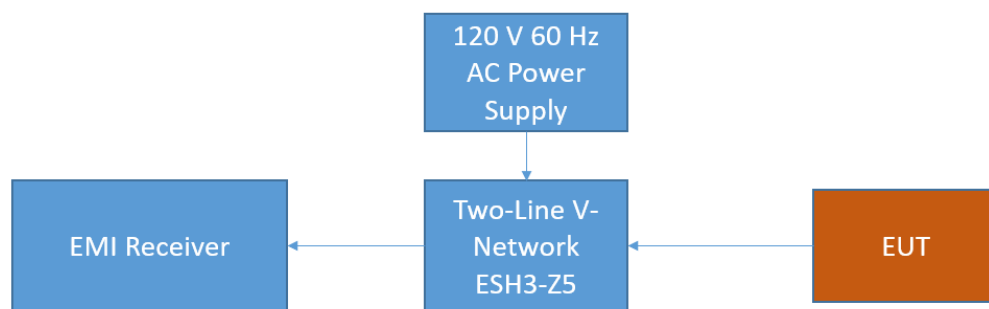

FCC Conducted Emissions on AC

The measurement procedure consists of two steps. It is implemented into the EMI test software EMC-32 from R&S.

#### **Step 1: Preliminary scan**

Intention of this step is, to determine the conducted EMI-profile of the EUT.

EMI receiver settings:

- Detector: Peak – Maxhold & Average
- Frequency range: 150 kHz – 30 MHz
- Frequency steps: 2.5 kHz
- IF-Bandwidth: 9 kHz
- Measuring time / Frequency step: 100 ms (FFT-based)
- Measurement on phase + neutral lines of the power cords

On basis of this preliminary scan the highest amplitudes and the corresponding frequencies relative to the limit are identified. Emissions above the limit and emissions which are in the 10 dB range below the limit are considered.

## Step 2: Final measurement

Intention of this step is, to determine the highest emissions with the settings defined in the test specification for the frequencies identified in step 1.

EMI receiver settings:

- Detector: Quasi-Peak & (CISPR) Average
- IF Bandwidth: 9 kHz
- Measuring time: 1 s / frequency

At each frequency determined in step 1, four measurements are performed in the following combinations:

- 1) Neutral lead - reference ground (PE grounded)
- 2) Phase lead - reference ground (PE grounded)
- 3) Neutral lead - reference ground (PE floating)
- 4) Phase lead - reference ground (PE floating)

The highest value is reported.

### 5.1.2 TEST REQUIREMENTS / LIMITS

FCC Part 15, Subpart B, §15.107

#### Class B:

Frequency (MHz)	QP Limits (dB $\mu$ V)	AV Limits (dB $\mu$ V)
0.15 - 0.5	66 - 56	56 - 46
0.5 - 5	56	46
5 - 30	60	50

#### Class A:

Frequency (MHz)	QP Limits (dB $\mu$ V)	AV Limits (dB $\mu$ V)
0.15 - 0.5	79	66
0.5 - 30	73	60

### 5.1.3 TEST PROTOCOL

Temperature: 24 °C  
 Air Pressure: 1001 hPa  
 Humidity: 37 %  
 via auxiliary equipment, stand-alone

Power line	PE	Frequency [MHz]	Level [dB $\mu$ V]	Detector	Limit [dB $\mu$ V]	Margin [dB]
-	-	-	-	-	-	-

Remark: Please see next sub-clause for the measurement plot.

#### 5.1.4 MEASUREMENT PLOT (EXAMPLE PLOT, SHOWING WORST CASE, IF APPLICABLE)

AC mains connection = via auxiliary equipment,  
Test setup = stand-alone  
(S01\_AT01)

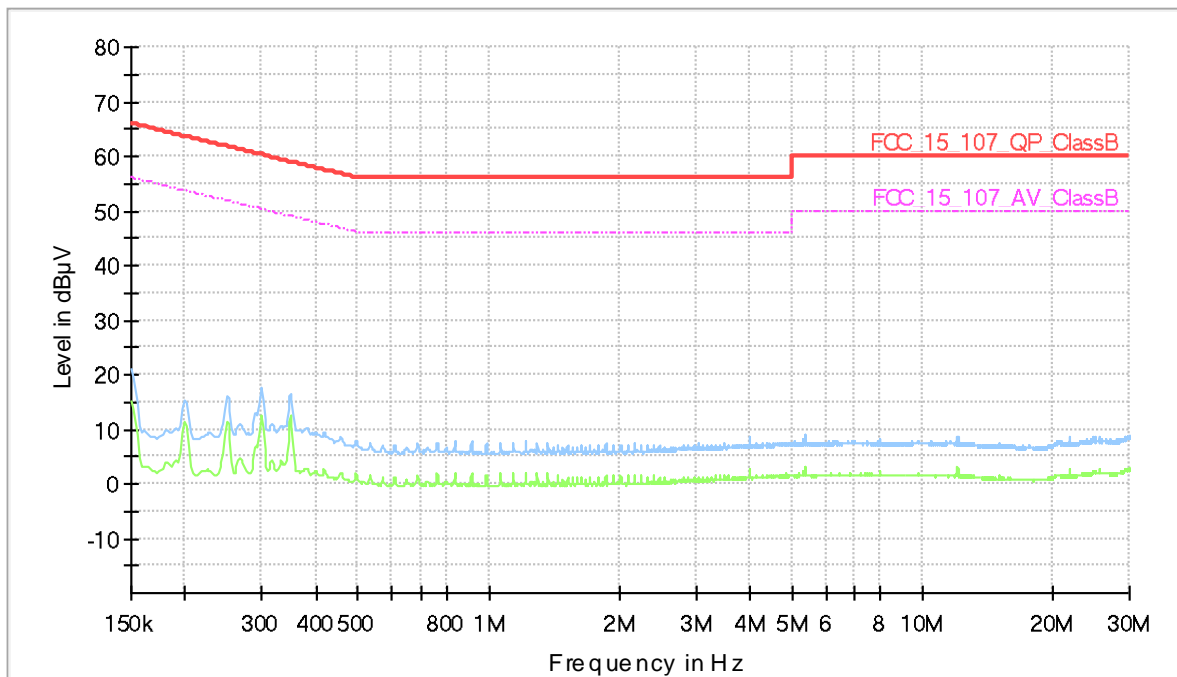

#### 5.1.5 TEST EQUIPMENT USED

- Conducted Emissions FCC

## 5.2 RADIATED EMISSIONS

Standard **FCC Part 15 Subpart B**

**The test was performed according to:**  
ANSI C63.4

### 5.2.1 TEST DESCRIPTION

The test set-up was made in accordance to the general provisions of ANSI C63.4 in a typical installation configuration. The measurements were performed according the following sub-chapters of ANSI C63.4:

- 30 MHz – 1 GHz: Chapter 8.3.2.1
- > 1 GHz: Chapter 8.3.2.2

The measurement procedure is implemented into the EMI test software EMC32 from R&S. Exploratory tests are performed at 3 orthogonal axes to determine the worst-case orientation of a body-worn or handheld EUT. The final test on all kind of EUTs is also performed at 3 axes. A pre-check is performed while the EUT is powered.

The Equipment Under Test (EUT) was set up on a non-conductive table in the semi-anechoic chamber. The influence of the EUT support table that is used between 30–1000 MHz was evaluated.

#### 1. Measurement setup

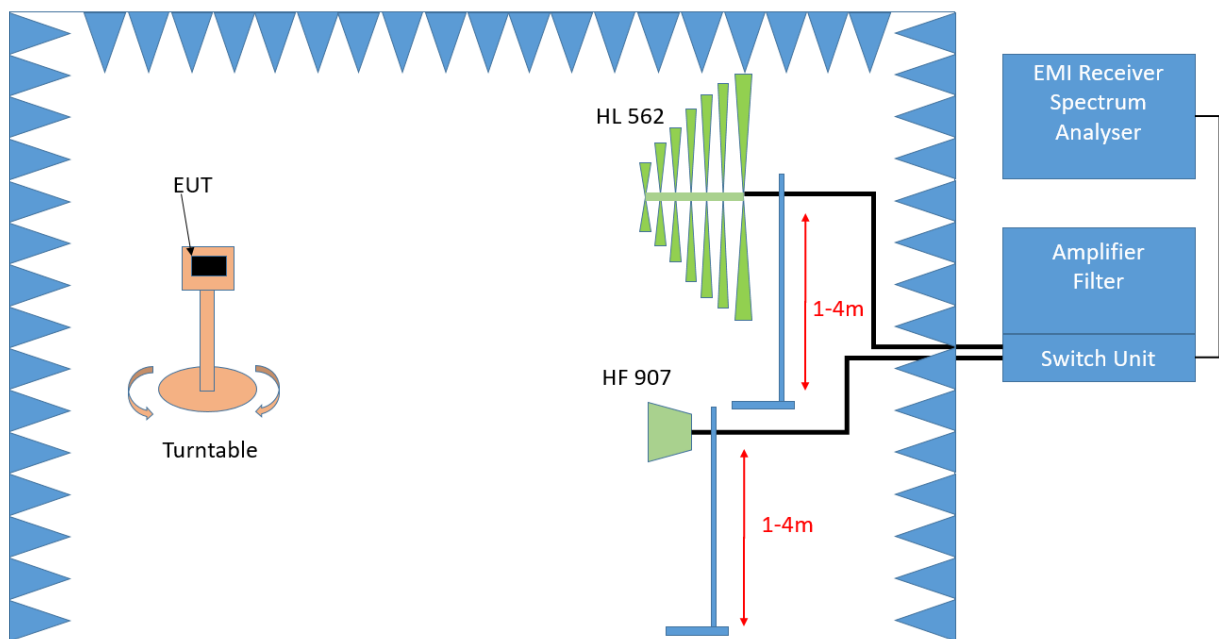

Test Setup; Spurious Emission Radiated (SAC)

## Frequency range 30 MHz – 1 GHz

### Step 1: Preliminary scan

This is a preliminary test to identify the highest amplitudes relative to the limit.

Settings for step 1:

- Antenna distance: 3 m
- Detector: Peak-Maxhold / Quasipeak (FFT-based)
- Frequency range: 30 – 1000 MHz
- Frequency steps: 30 kHz
- IF-Bandwidth: 120 kHz
- Measuring time / Frequency step: 100 ms
- Turntable angle range:  $-180^{\circ}$  to  $90^{\circ}$
- Turntable step size:  $90^{\circ}$
- Height variation range: 1 – 4 m
- Height variation step size: 1.5 m
- Polarisation: Horizontal + Vertical

Intention of this step is, to determine the radiated EMI-profile of the EUT. Afterwards the relevant emissions for the final measurement are identified.

### Step 2: Adjustment measurement

In this step the accuracy of the turntable azimuth and antenna height will be improved. This is necessary to find out the maximum value of every frequency.

For each frequency, which was determined the turntable azimuth and antenna height will be adjusted. The turntable azimuth will slowly vary by  $360^{\circ}$ . During this action, the value of emission is continuously measured. The turntable azimuth at the highest emission will be recorded and adjusted. In this position, the antenna height will slowly vary between 1 – 4 m. During this action, the value of emission is also continuously measured. The antenna height of the highest emission will also be recorded and adjusted.

- Detector: Peak – Maxhold
- Measured frequencies: in step 1 determined frequencies
- IF – Bandwidth: 120 kHz
- Measuring time: 100 ms
- Turntable angle range:  $360^{\circ}$
- Height variation range: 1 – 4 m
- Antenna Polarisation: max. value determined in step 1

### Step 3: Final measurement with QP detector

With the settings determined in step 2, the final measurement will be performed:

EMI receiver settings for step 3:

- Detector: Quasi-Peak
- Measured frequencies: in step 1 determined frequencies
- IF – Bandwidth: 120 kHz
- Measuring time: 1 s

**Above 1 GHz:**

The following changes apply to the measurement procedure for the frequency range > 1 GHz:

**Step 1:**

- Turntable step size: 45°
- Detector: Peak, Average (Maxhold)
- IF – Bandwidth: 1 MHz
- Frequency steps: 250 kHz
- Measuring time: 500 ms / GHz

**Step 2:**

- IF – Bandwidth: 1 MHz

**Step 3:**

- Detector: Peak / CISPR Average
- IF – Bandwidth: 1 MHz

After every measurement a plot will be generated which contains a diagram with the results of the preliminary scan and a chart with the frequencies and values of the results of the final measurement.

**5.2.2 TEST REQUIREMENTS / LIMITS**

FCC Part 15, Subpart B, §15.109, Radiated Emission Limits

**Class B:**

Frequency (MHz)	Limit (µV/m)	Measurement distance (m)	Limits (dBµV/m)
30 – 88	100@3m	3	40.0@3m
88 – 216	150@3m	3	43.5@3m
216 – 960	200@3m	3	46.0@3m
960 – 26000	500@3m	3	54.0@3m
26000 – 40000	500@3m	1	54.0@3m

**Class A:**

Frequency (MHz)	Limit (µV/m)	Measurement distance (m)	Limits (dBµV/m)
30 – 88	90@10m	3	39.1@10m
88 – 216	150@10m	3	43.5@10m
216 – 960	210@10m	3	46.4@10m
960 – 26000	300@10m	3	49.5@10m
26000 – 40000	300@10m	1	49.5@10m

The measured values for Class A and for Class B (> 26 GHz) measurements are corrected with an inverse linear distance extrapolation factor (20 dB/decade).

§15.35(b) ..., there is also a limit on the radio frequency emissions, as measured using instrumentation with a peak detector function, corresponding to 20 dB above the maximum permitted average limit....

Used conversion factor:  $\text{Limit (dB}\mu\text{V/m)} = 20 \log (\text{Limit } (\mu\text{V/m})/1\mu\text{V/m)}$



### 5.2.3 TEST PROTOCOL

Ambient temperature: 23 °C  
 Air Pressure: 999 hPa  
 Humidity: 40 %  
 via auxiliary equipment,  
 stand-alone

Spurious Freq. [MHz]	Spurious Level [dB $\mu$ V/m]	Detector	RBW [kHz]	Limit [dB $\mu$ V/m]	Margin to Limit [dB]
899.19	18.12	QP	120.00	46.00	27.88

Remark: Please see next sub-clause for the measurement plot.

### 5.2.4 MEASUREMENT PLOT (EXAMPLE PLOT, SHOWING WORST CASE, IF APPLICABLE)

AC mains connection = via auxiliary equipment, Measurement range = 30 MHz - 1 GHz,  
 Test setup = stand-alone  
 (S01\_AT01)

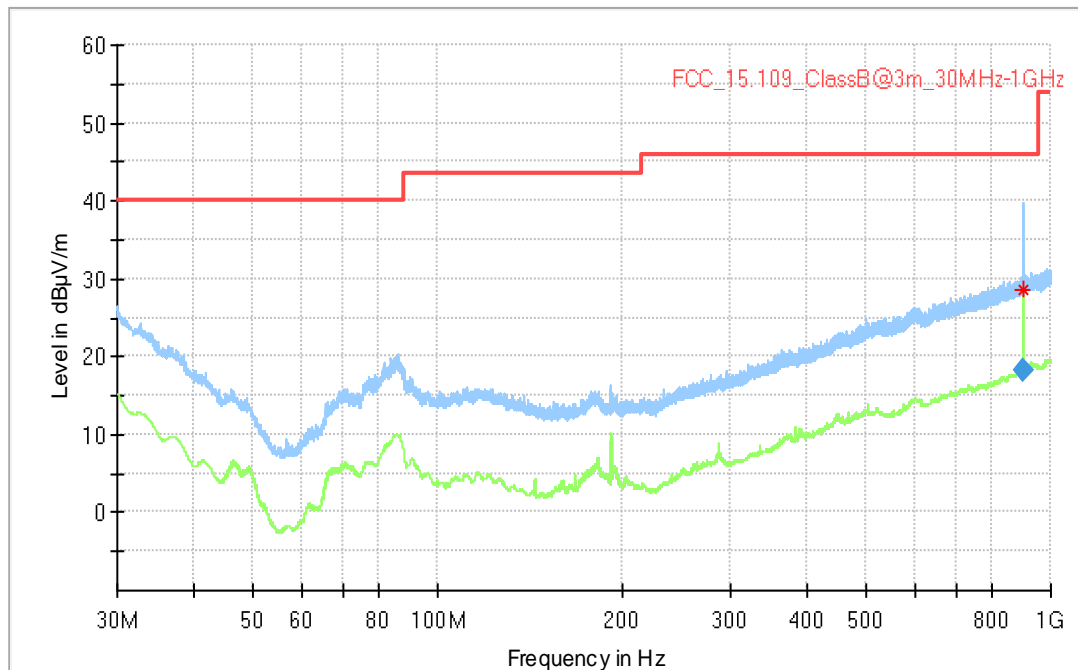

AC mains connection = via auxiliary equipment, Measurement range = 1 GHz - 18 GHz,  
 Test setup = stand-alone  
 (S01\_AT01)

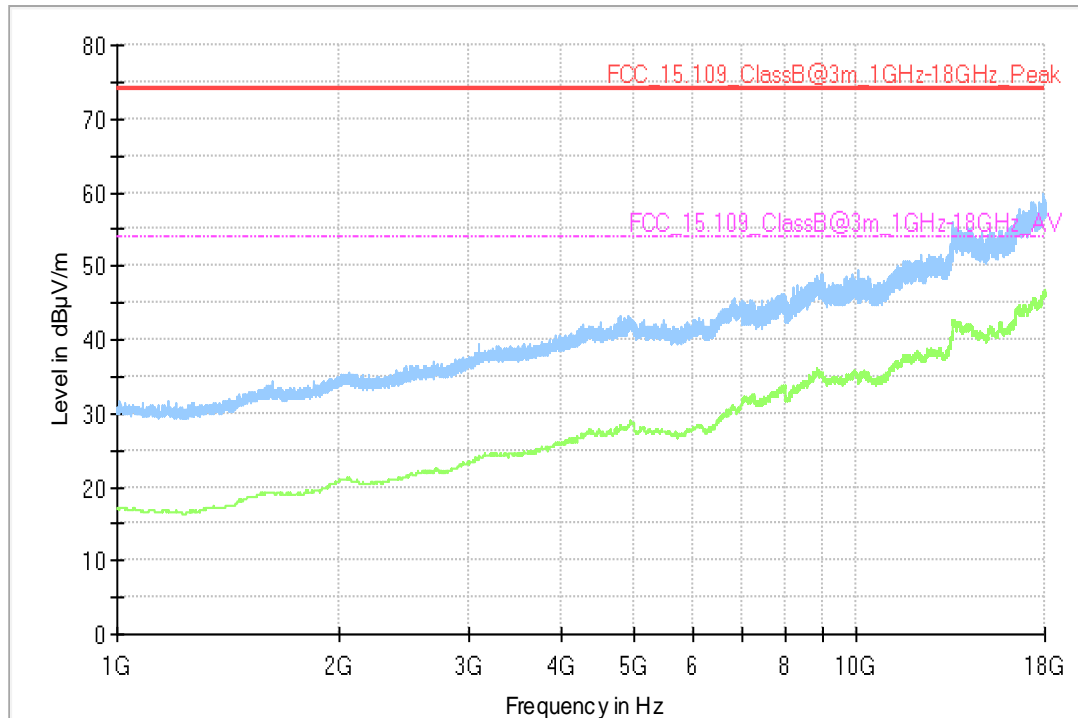

### 5.2.5 TEST EQUIPMENT USED

- Radiated Emissions

## 6 TEST EQUIPMENT

- 1 Conducted Emissions FCC  
Conducted Emissions AC Mains for FCC standards

Ref.No.	Device Name	Description	Manufacturer	Serial Number	Last Calibration	Calibration Due
1.1	MFS	Rubidium Frequency Normal MFS	Datum GmbH	002	2020-11	2021-11
1.2	Opus10 TPR (8253.00)	T/P Logger 13	Lufft Mess- und Regeltechnik GmbH	13936	2019-05	2021-05
1.3	ESH3-Z5	Two-Line V-Network (AUX)	Rohde & Schwarz GmbH & Co. KG	828304/029	2019-06	2021-06
1.4	EP 1200/B, NA/B1	AC Source, Amplifier with integrated variable Oscillator	Spitzenberger & Spies GmbH & Co. KG	B6278		
1.5	Chroma 6404	AC Source	Chroma ATE INC.	64040001304		
1.6	Shielded Room 02	Shielded Room 4m x 3m	Frankonia Germany EMC Solution GmbH	-		
1.7	ESH3-Z5	Two-Line V-Network (EUT)	Rohde & Schwarz GmbH & Co. KG	829996/002	2019-06	2021-06
1.8	ESR 7	EMI Receiver / Spectrum Analyzer	Rohde & Schwarz	101424	2021-01	2023-01
1.9	Opus10 THI (8152.00)	T/H Logger 02	Lufft Mess- und Regeltechnik GmbH	7489	2019-05	2021-05

- 2 Radiated Emissions  
Lab to perform radiated emission tests

Ref.No.	Device Name	Description	Manufacturer	Serial Number	Last Calibration	Calibration Due
2.1	MFS	Rubidium Frequency Normal MFS	Datum GmbH	002	2020-11	2021-11
2.2	N5000/NP	Filter for EUT, 2 Lines, 250 V, 16 A	ETS-LINDGREN	241515		
2.3	Opus10 TPR (8253.00)	T/P Logger 13	Lufft Mess- und Regeltechnik GmbH	13936	2019-05	2021-05
2.4	ESW44	EMI Receiver / Spectrum Analyzer	Rohde & Schwarz GmbH & Co. KG	101603	2019-12	2021-12
2.5	Anechoic Chamber 01	SAC/FAR, 10.58 m x 6.38 m x 6.00 m	Frankonia	none	2018-06	2021-06
2.6	HL 562 ULTRALOG	Biconical-log-per antenna (30 MHz - 3 GHz) with HL 562E biconicals	Rohde & Schwarz GmbH & Co. KG	830547/003	2018-07	2021-07
2.7	AMF-7D00101800-30-10P-R	Broadband Amplifier 100 MHz - 18 GHz	Miteq			

Ref.No.	Device Name	Description	Manufacturer	Serial Number	Last Calibration	Calibration Due
2.8	5HC2700/12750-1.5-KK	High Pass Filter	Trilithic	9942012		
2.9	ASP 1.2/1.8-10 kg	Antenna Mast	Maturo GmbH	-		
2.10	WRD1920/1980-5/22-5EESD	Tunable Band Reject Filter	Wainwright Instruments GmbH	11		
2.11	TDS 784C	Digital Oscilloscope [SA2] (Aux)	Tektronix	B021311		
2.12	Opus10 THI (8152.00)	T/H Logger 10	Luftt Mess- und Regeltechnik GmbH	12488	2019-06	2021-06
2.13	foRS232 Unit 2	Fibre optic link RS232	PONTIS Messtechnik GmbH	4031516037		
2.14	PONTIS Con4101	PONTIS Camera Controller		6061510370		
2.15	HF 906	Double-ridged horn	Rohde & Schwarz	357357/002	2018-09	2021-09
2.16	FSW 43	Spectrum Analyzer	Rohde & Schwarz	103779	2019-02	2021-08
2.17	EP 1200/B, NA/B1	AC Source, Amplifier with integrated variable Oscillator	Spitzenberger & Spies GmbH & Co. KG	B6278		
2.18	3160-09	Standard Gain / Pyramidal Horn Antenna 26.5 GHz	EMCO Elektronik GmbH	00083069		
2.19	foRS232 Unit 1	Fibre optic link RS232	PONTIS Messtechnik GmbH	4021516036		
2.20	FSP3	Spectrum Analyzer	Rohde & Schwarz GmbH & Co. KG	836722/011		
2.21	WHKX 7.0/18G-8SS	High Pass Filter	Wainwright Instruments GmbH	09		
2.22	DS 420S	Turn Table 2 m diameter	HD GmbH	420/573/99		
2.23	4HC1600/12750-1.5-KK	High Pass Filter	Trilithic	9942011		
2.24	WRCD1879.8-0.2/40-10EE	Notch Filter Ultra Stable	Wainwright Instruments GmbH	16		
2.25	JS4-00102600-42-5A	Broadband Amplifier 30 MHz - 26 GHz	Miteq	619368		
2.26	TT 1.5 WI	Turn Table	Maturo GmbH	-		
2.27	HL 562 ULTRALOG	Biconical-log-per Antenna (30 MHz - 3 GHz)	Rohde & Schwarz GmbH & Co. KG	100609	2019-05	2022-05
2.28	HF 906	Double-ridged horn	Rohde & Schwarz	357357/001		
2.29	FS-Z325	Harmonic Mixer 220 - 325 GHz	Rohde & Schwarz Messgerätebau GmbH	101006	2020-03	2023-03
2.30	3160-10	Standard Gain / Pyramidal Horn Antenna 40 GHz	EMCO Elektronik GmbH	00086675		

Ref.No.	Device Name	Description	Manufacturer	Serial Number	Last Calibration	Calibration Due
2.31	MA4985-XP-ET	Bore Sight Antenna Mast	innco systems GmbH	none		
2.32	VLFX-650+	Low Pass Filter DC650 MHz	Mini-Circuits	15542		
2.33	JUN-AIR Mod. 6-15	Air Compressor	JUN-AIR Deutschland GmbH	612582		
2.34	5HC3500/18000-1.2-KK	High Pass Filter	Trilithic	200035008		
2.35	OLS-1 M	Fibre optic link USB 1.1	Ingenieurbüro Scheiba	018		
2.36	HFH2-Z2	Loop Antenna + 3 Axis Tripod	Rohde & Schwarz GmbH & Co. KG	829324/006	2021-01	2024-01
2.37	Voltcraft M-3860M	Digital Multimeter 01 (Multimeter)	Conrad	IJ096055		
2.38	FSU3	Spectrum Analyser (20 Hz to 3.6 GHz)	Rohde & Schwarz GmbH & Co. KG	200046		
2.39	ESR 7	EMI Receiver / Spectrum Analyzer	Rohde & Schwarz	101424	2021-01	2023-01
2.40	SB4-100.OLD20-3T/10 Airwin 2 x 1.5 kW	Air compressor (oil-free)	airWin Kompressoren UG	901/00503		
2.41	UNI-T UT195E	True RMS Digital Multimeter	UNI-T UNI-TREND TECHNOLOGY (CHINA) CO., LTD.	C190729561		
2.42	JS4-00101800-35-5P	Broadband Amplifier 30 MHz - 18 GHz	Miteq	896037		
2.43	AS 620 P	Antenna Mast (pneumatic polarisation)	HD GmbH	620/37		
2.44	FSU26	Spectrum Analyser (20 Hz to 26.5 GHz)	Rohde & Schwarz GmbH & Co. KG	100136		
2.45	6005D (30 V / 5 A)	Laboratory Power Supply 120 V 60 Hz	PeakTech	81062045		
2.46	TD1.5-10kg	EUT Tilt Device (Rohacell)	Maturo GmbH	TD1.5-10kg/024/3790709		
2.47	foUSB-M Converter 1	Fibre optic link USB 2.0	Audiovo GmbH (PONTIS EMC)	4461520060		
2.48	Innco Systems CO3000	Controller for bore sight mast SAC	innco systems GmbH	CO3000/967/39371016/L		
2.49	NRV-Z1	Sensor Head B	Rohde & Schwarz GmbH & Co. KG	827753/006	2020-08	2021-08
2.50	HF 907-2	Double-ridged horn	Rohde & Schwarz	102817	2019-04	2022-04
2.51	PAS 2.5 - 10 kg	Antenna Mast	Maturo GmbH	-		
2.52	AFS42-00101800-25-S-42	Broadband Amplifier 25 MHz - 18 GHz	Miteq	2035324		

Ref.No.	Device Name	Description	Manufacturer	Serial Number	Last Calibration	Calibration Due
2.53	WRCA800/960-0.2/40-6EEK	Tunable Notch Filter	Wainwright Instruments GmbH	20		
2.54	AM 4.0	Antenna Mast 4 m	Maturo GmbH	AM4.0/180/11920513		
2.55	HF 907	Double-ridged horn	Rohde & Schwarz	102444	2018-07	2021-07
2.56	E4408B	Spectrum Analyser (9 kHz to 26.5 GHz)	Agilent Technologies Deutschland GmbH	MY45103714		

The calibration interval is the time interval between "Last Calibration" and "Calibration Due"

## 7 ANTENNA FACTORS, CABLE LOSS AND SAMPLE CALCULATIONS

This chapter contains the antenna factors with their corresponding path loss of the used measurement path for all antennas as well as the insertion loss of the LISN.

### 7.1 LISN R&S ESH3-Z5 (150 KHZ – 30 MHZ)

Frequency MHz	Corr. dB	LISN insertion loss ESH3- Z5 dB	cable loss (incl. 10 dB atten- uator) dB
0.15	10.1	0.1	10.0
5	10.3	0.1	10.2
7	10.5	0.2	10.3
10	10.5	0.2	10.3
12	10.7	0.3	10.4
14	10.7	0.3	10.4
16	10.8	0.4	10.4
18	10.9	0.4	10.5
20	10.9	0.4	10.5
22	11.1	0.5	10.6
24	11.1	0.5	10.6
26	11.2	0.5	10.7
28	11.2	0.5	10.7
30	11.3	0.5	10.8

#### Sample calculation

$$U_{\text{LISN}} (\text{dB } \mu\text{V}) = U (\text{dB } \mu\text{V}) + \text{Corr. (dB)}$$

U = Receiver reading

LISN Insertion loss = Voltage Division Factor of LISN

Corr. = sum of single correction factors of used LISN, cables, switch units (if used)

Linear interpolation will be used for frequencies in between the values in the table.

## 7.2 ANTENNA R&S HFH2-Z2 (9 KHZ – 30 MHZ)

Frequency MHz	AF HFH-Z2) dB (1/m)	Corr. dB	cable loss 1 (inside chamber) dB	cable loss 2 (outside chamber) dB	cable loss 3 (switch unit) dB	cable loss 4 (to receiver) dB	distance corr. (-40 dB/ decade) dB	d <sub>Limit</sub> (meas. distance (limit) m	d <sub>used</sub> (meas. distance (used) m
0.009	20.50	-79.6	0.1	0.1	0.1	0.1	-80	300	3
0.01	20.45	-79.6	0.1	0.1	0.1	0.1	-80	300	3
0.015	20.37	-79.6	0.1	0.1	0.1	0.1	-80	300	3
0.02	20.36	-79.6	0.1	0.1	0.1	0.1	-80	300	3
0.025	20.38	-79.6	0.1	0.1	0.1	0.1	-80	300	3
0.03	20.32	-79.6	0.1	0.1	0.1	0.1	-80	300	3
0.05	20.35	-79.6	0.1	0.1	0.1	0.1	-80	300	3
0.08	20.30	-79.6	0.1	0.1	0.1	0.1	-80	300	3
0.1	20.20	-79.6	0.1	0.1	0.1	0.1	-80	300	3
0.2	20.17	-79.6	0.1	0.1	0.1	0.1	-80	300	3
0.3	20.14	-79.6	0.1	0.1	0.1	0.1	-80	300	3
0.49	20.12	-79.6	0.1	0.1	0.1	0.1	-80	300	3
0.490001	20.12	-39.6	0.1	0.1	0.1	0.1	-40	30	3
0.5	20.11	-39.6	0.1	0.1	0.1	0.1	-40	30	3
0.8	20.10	-39.6	0.1	0.1	0.1	0.1	-40	30	3
1	20.09	-39.6	0.1	0.1	0.1	0.1	-40	30	3
2	20.08	-39.6	0.1	0.1	0.1	0.1	-40	30	3
3	20.06	-39.6	0.1	0.1	0.1	0.1	-40	30	3
4	20.05	-39.5	0.2	0.1	0.1	0.1	-40	30	3
5	20.05	-39.5	0.2	0.1	0.1	0.1	-40	30	3
6	20.02	-39.5	0.2	0.1	0.1	0.1	-40	30	3
8	19.95	-39.5	0.2	0.1	0.1	0.1	-40	30	3
10	19.83	-39.4	0.2	0.1	0.2	0.1	-40	30	3
12	19.71	-39.4	0.2	0.1	0.2	0.1	-40	30	3
14	19.54	-39.4	0.2	0.1	0.2	0.1	-40	30	3
16	19.53	-39.3	0.3	0.1	0.2	0.1	-40	30	3
18	19.50	-39.3	0.3	0.1	0.2	0.1	-40	30	3
20	19.57	-39.3	0.3	0.1	0.2	0.1	-40	30	3
22	19.61	-39.3	0.3	0.1	0.2	0.1	-40	30	3
24	19.61	-39.3	0.3	0.1	0.2	0.1	-40	30	3
26	19.54	-39.3	0.3	0.1	0.2	0.1	-40	30	3
28	19.46	-39.2	0.3	0.1	0.3	0.1	-40	30	3
30	19.73	-39.1	0.4	0.1	0.3	0.1	-40	30	3

### Sample calculation

$$E \text{ (dB } \mu\text{V/m)} = U \text{ (dB } \mu\text{V)} + AF \text{ (dB 1/m)} + Corr. \text{ (dB)}$$

U = Receiver reading

AF = Antenna factor

Corr. = sum of single correction factors of used cables, switch unit, distance correction, amplifier (if applicable)

distance correction =  $-40 * \text{LOG} (d_{\text{Limit}} / d_{\text{used}})$

Linear interpolation will be used for frequencies in between the values in the table.

Table shows an extract of values



### 7.3 ANTENNA R&S HL562 (30 MHz – 1 GHz)

( $d_{Limit} = 3\text{ m}$ )

Frequency	AF R&S HL562	Corr.
MHz	dB (1/m)	dB
30	18.6	0.6
50	6.0	0.9
100	9.7	1.2
150	7.9	1.6
200	7.6	1.9
250	9.5	2.1
300	11.0	2.3
350	12.4	2.6
400	13.6	2.9
450	14.7	3.1
500	15.6	3.2
550	16.3	3.5
600	17.2	3.5
650	18.1	3.6
700	18.5	3.6
750	19.1	4.1
800	19.6	4.1
850	20.1	4.4
900	20.8	4.7
950	21.1	4.8
1000	21.6	4.9

cable loss 1 (inside chamber)	cable loss 2 (outside chamber)	cable loss 3 (switch unit)	cable loss 4 (to receiver)	distance corr. (-20 dB/ decade)	$d_{Limit}$ (meas. distance (limit))	$d_{used}$ (meas. distance (used))
dB	dB	dB	dB	dB	m	m
0.29	0.04	0.23	0.02	0.0	3	3
0.39	0.09	0.32	0.08	0.0	3	3
0.56	0.14	0.47	0.08	0.0	3	3
0.73	0.20	0.59	0.12	0.0	3	3
0.84	0.21	0.70	0.11	0.0	3	3
0.98	0.24	0.80	0.13	0.0	3	3
1.04	0.26	0.89	0.15	0.0	3	3
1.18	0.31	0.96	0.13	0.0	3	3
1.28	0.35	1.03	0.19	0.0	3	3
1.39	0.38	1.11	0.22	0.0	3	3
1.44	0.39	1.20	0.19	0.0	3	3
1.55	0.46	1.24	0.23	0.0	3	3
1.59	0.43	1.29	0.23	0.0	3	3
1.67	0.34	1.35	0.22	0.0	3	3
1.67	0.42	1.41	0.15	0.0	3	3
1.87	0.54	1.46	0.25	0.0	3	3
1.90	0.46	1.51	0.25	0.0	3	3
1.99	0.60	1.56	0.27	0.0	3	3
2.14	0.60	1.63	0.29	0.0	3	3
2.22	0.60	1.66	0.33	0.0	3	3
2.23	0.61	1.71	0.30	0.0	3	3

( $d_{Limit} = 10\text{ m}$ )

30	18.6	-9.9
50	6.0	-9.6
100	9.7	-9.2
150	7.9	-8.8
200	7.6	-8.6
250	9.5	-8.3
300	11.0	-8.1
350	12.4	-7.9
400	13.6	-7.6
450	14.7	-7.4
500	15.6	-7.2
550	16.3	-7.0
600	17.2	-6.9
650	18.1	-6.9
700	18.5	-6.8
750	19.1	-6.3
800	19.6	-6.3
850	20.1	-6.0
900	20.8	-5.8
950	21.1	-5.6
1000	21.6	-5.6

0.29	0.04	0.23	0.02	-10.5	10	3
0.39	0.09	0.32	0.08	-10.5	10	3
0.56	0.14	0.47	0.08	-10.5	10	3
0.73	0.20	0.59	0.12	-10.5	10	3
0.84	0.21	0.70	0.11	-10.5	10	3
0.98	0.24	0.80	0.13	-10.5	10	3
1.04	0.26	0.89	0.15	-10.5	10	3
1.18	0.31	0.96	0.13	-10.5	10	3
1.28	0.35	1.03	0.19	-10.5	10	3
1.39	0.38	1.11	0.22	-10.5	10	3
1.44	0.39	1.20	0.19	-10.5	10	3
1.55	0.46	1.24	0.23	-10.5	10	3
1.59	0.43	1.29	0.23	-10.5	10	3
1.67	0.34	1.35	0.22	-10.5	10	3
1.67	0.42	1.41	0.15	-10.5	10	3
1.87	0.54	1.46	0.25	-10.5	10	3
1.90	0.46	1.51	0.25	-10.5	10	3
1.99	0.60	1.56	0.27	-10.5	10	3
2.14	0.60	1.63	0.29	-10.5	10	3
2.22	0.60	1.66	0.33	-10.5	10	3
2.23	0.61	1.71	0.30	-10.5	10	3

#### Sample calculation

$$E \text{ (dB } \mu\text{V/m)} = U \text{ (dB } \mu\text{V)} + \text{AF (dB 1/m)} + \text{Corr. (dB)}$$

U = Receiver reading

AF = Antenna factor

Corr. = sum of single correction factors of used cables, switch unit, distance correction, amplifier (if applicable)

distance correction =  $-20 * \text{LOG} (d_{Limit} / d_{used})$

Linear interpolation will be used for frequencies in between the values in the table.

Tables show an extract of values.

### 7.4 ANTENNA R&S HF907 (1 GHZ – 18 GHZ)

Frequency MHz	AF R&S HF907 dB (1/m)	Corr. dB
1000	24.4	-19.4
2000	28.5	-17.4
3000	31.0	-16.1
4000	33.1	-14.7
5000	34.4	-13.7
6000	34.7	-12.7
7000	35.6	-11.0

cable loss 1 (relay + cable inside chamber) dB	cable loss 2 (outside chamber) dB	cable loss 3 (switch unit, atten- uator & pre-amp) dB	cable loss 4 (to receiver) dB
0.99	0.31	-21.51	0.79
1.44	0.44	-20.63	1.38
1.87	0.53	-19.85	1.33
2.41	0.67	-19.13	1.31
2.78	0.86	-18.71	1.40
2.74	0.90	-17.83	1.47
2.82	0.86	-16.19	1.46

Frequency MHz	AF R&S HF907 dB (1/m)	Corr. dB
3000	31.0	-23.4
4000	33.1	-23.3
5000	34.4	-21.7
6000	34.7	-21.2
7000	35.6	-19.8

cable loss 1 (relay inside chamber) dB	cable loss 2 (inside chamber) dB	cable loss 3 (outside chamber) dB	cable loss 4 (switch unit, atten- uator & pre-amp) dB	cable loss 5 (to receiver) dB	used for FCC 15.247
0.47	1.87	0.53	-27.58	1.33	
0.56	2.41	0.67	-28.23	1.31	
0.61	2.78	0.86	-27.35	1.40	
0.58	2.74	0.90	-26.89	1.47	
0.66	2.82	0.86	-25.58	1.46	

Frequency MHz	AF R&S HF907 dB (1/m)	Corr. dB
7000	35.6	-57.3
8000	36.3	-56.3
9000	37.1	-55.3
10000	37.5	-56.2
11000	37.5	-55.3
12000	37.6	-53.7
13000	38.2	-53.5
14000	39.9	-56.3
15000	40.9	-54.1
16000	41.3	-54.1
17000	42.8	-54.4
18000	44.2	-54.7

cable loss 1 (relay inside chamber) dB	cable loss 2 (High Pass) dB	cable loss 3 (pre- amp) dB	cable loss 4 (inside chamber) dB	cable loss 5 (outside chamber) dB	cable loss 6 (to receiver) dB
0.56	1.28	-62.72	2.66	0.94	1.46
0.69	0.71	-61.49	2.84	1.00	1.53
0.68	0.65	-60.80	3.06	1.09	1.60
0.70	0.54	-61.91	3.28	1.20	1.67
0.80	0.61	-61.40	3.43	1.27	1.70
0.84	0.42	-59.70	3.53	1.26	1.73
0.83	0.44	-59.81	3.75	1.32	1.83
0.91	0.53	-63.03	3.91	1.40	1.77
0.98	0.54	-61.05	4.02	1.44	1.83
1.23	0.49	-61.51	4.17	1.51	1.85
1.36	0.76	-62.36	4.34	1.53	2.00
1.70	0.53	-62.88	4.41	1.55	1.91

#### Sample calculation

$$E \text{ (dB } \mu\text{V/m)} = U \text{ (dB } \mu\text{V)} + \text{AF (dB 1/m)} + \text{Corr. (dB)}$$

U = Receiver reading

AF = Antenna factor

Corr. = sum of single correction factors of used cables, switch unit, distance correction, amplifier (if applicable)

Linear interpolation will be used for frequencies in between the values in the table.

Tables show an extract of values.

### 7.5 ANTENNA EMCO 3160-09 (18 GHZ – 26.5 GHZ)

Frequency MHz	AF EMCO 3160-09 dB (1/m)	Corr. dB
18000	40.2	-23.5
18500	40.2	-23.2
19000	40.2	-22.0
19500	40.3	-21.3
20000	40.3	-20.3
20500	40.3	-19.9
21000	40.3	-19.1
21500	40.3	-19.1
22000	40.3	-18.7
22500	40.4	-19.0
23000	40.4	-19.5
23500	40.4	-19.3
24000	40.4	-19.8
24500	40.4	-19.5
25000	40.4	-19.3
25500	40.5	-20.4
26000	40.5	-21.3
26500	40.5	-21.1

cable loss 1 (inside chamber) dB	cable loss 2 (pre- amp) dB	cable loss 3 (inside chamber) dB	cable loss 4 (switch unit) dB	cable loss 5 (to receiver) dB
0.72	-35.85	6.20	2.81	2.65
0.69	-35.71	6.46	2.76	2.59
0.76	-35.44	6.69	3.15	2.79
0.74	-35.07	7.04	3.11	2.91
0.72	-34.49	7.30	3.07	3.05
0.78	-34.46	7.48	3.12	3.15
0.87	-34.07	7.61	3.20	3.33
0.90	-33.96	7.47	3.28	3.19
0.89	-33.57	7.34	3.35	3.28
0.87	-33.66	7.06	3.75	2.94
0.88	-33.75	6.92	3.77	2.70
0.90	-33.35	6.99	3.52	2.66
0.88	-33.99	6.88	3.88	2.58
0.91	-33.89	7.01	3.93	2.51
0.88	-33.00	6.72	3.96	2.14
0.89	-34.07	6.90	3.66	2.22
0.86	-35.11	7.02	3.69	2.28
0.90	-35.20	7.15	3.91	2.36

#### Sample calculation

$$E \text{ (dB } \mu\text{V/m)} = U \text{ (dB } \mu\text{V)} + AF \text{ (dB 1/m)} + Corr. \text{ (dB)}$$

U = Receiver reading

AF = Antenna factor

Corr. = sum of single correction factors of used cables, switch unit, distance correction, amplifier (if applicable)

Linear interpolation will be used for frequencies in between the values in the table.

Table shows an extract of values.

## 7.6 ANTENNA EMCO 3160-10 (26.5 GHZ – 40 GHZ)

Frequency GHz	AF EMCO 3160-10 dB (1/m)	Corr. dB	cable loss 1 (inside chamber) dB	cable loss 2 (outside chamber) dB	cable loss 3 (switch unit) dB	cable loss 4 (to receiver) dB	distance corr. (-20 dB/ decade) dB	d <sub>Limit</sub> (meas. distance (limit) m	d <sub>used</sub> (meas. distance (used) m
26.5	43.4	-11.2	4.4				-9.5	3	1.0
27.0	43.4	-11.2	4.4				-9.5	3	1.0
28.0	43.4	-11.1	4.5				-9.5	3	1.0
29.0	43.5	-11.0	4.6				-9.5	3	1.0
30.0	43.5	-10.9	4.7				-9.5	3	1.0
31.0	43.5	-10.8	4.7				-9.5	3	1.0
32.0	43.5	-10.7	4.8				-9.5	3	1.0
33.0	43.6	-10.7	4.9				-9.5	3	1.0
34.0	43.6	-10.6	5.0				-9.5	3	1.0
35.0	43.6	-10.5	5.1				-9.5	3	1.0
36.0	43.6	-10.4	5.1				-9.5	3	1.0
37.0	43.7	-10.3	5.2				-9.5	3	1.0
38.0	43.7	-10.2	5.3				-9.5	3	1.0
39.0	43.7	-10.2	5.4				-9.5	3	1.0
40.0	43.8	-10.1	5.5				-9.5	3	1.0

### Sample calculation

$$E \text{ (dB } \mu\text{V/m)} = U \text{ (dB } \mu\text{V)} + \text{AF (dB 1/m)} + \text{Corr. (dB)}$$

U = Receiver reading

AF = Antenna factor

Corr. = sum of single correction factors of used cables, switch unit, distance correction, amplifier (if applicable)

Linear interpolation will be used for frequencies in between the values in the table.

distance correction =  $-20 * \text{LOG} (d_{\text{Limit}} / d_{\text{used}})$

Linear interpolation will be used for frequencies in between the values in the table.

Table shows an extract of values.

## 8 MEASUREMENT UNCERTAINTIES

Test Case	Parameter	Uncertainty
Conducted Emissions at AC mains	Voltage	± 3.4 dB
Radiated Emissions	Field Strength	± 5.5 dB

The measurement uncertainties for all parameters are calculated with an expansion factor (coverage factor)  $k = 1.96$ . This means, that the true value is in the corresponding interval with a probability of 95 %.

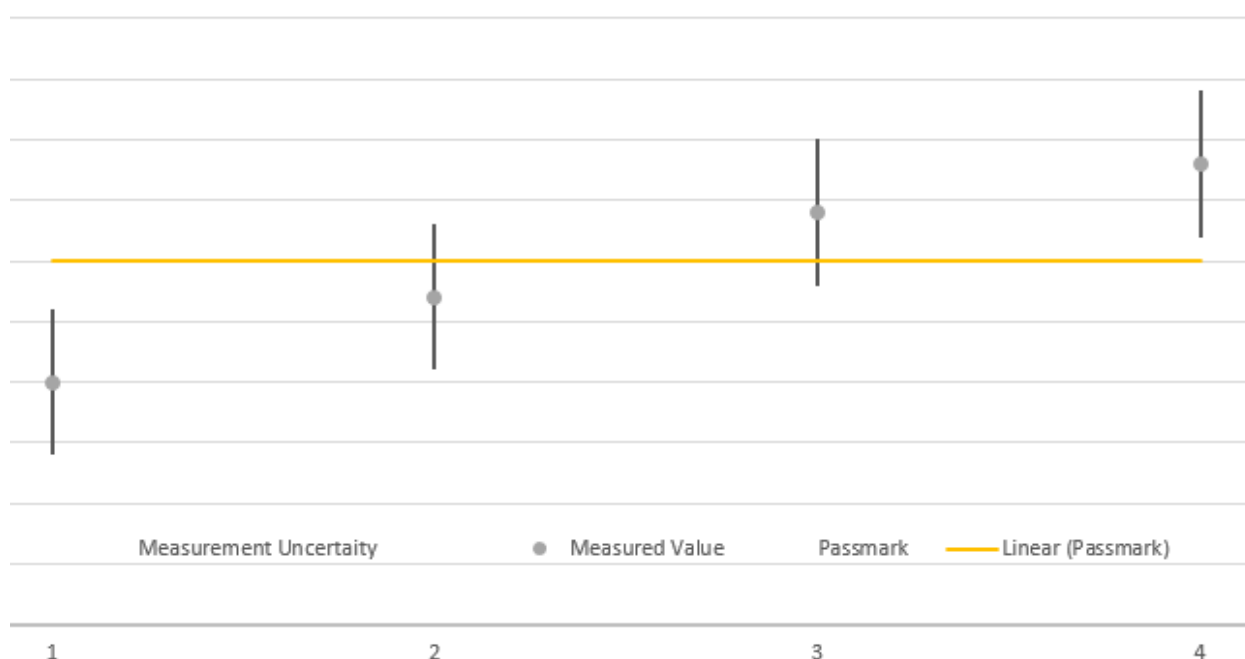

The verdicts in this test report are given according the above diagram:

Case	Measured Value	Uncertainty Range	Verdict
1	below pass mark	below pass mark	Passed
2	below pass mark	within pass mark	Passed
3	above pass mark	within pass mark	Failed
4	above pass mark	above pass mark	Failed

That means, the laboratory applies, as decision rule (see ISO/IEC 17025:2017), the so called shared risk principle.

## 9 PHOTO REPORT

Please see separate photo report.