

1. 184N Transceiver Function Description:

The 184N transceiver is the interface device between an ECU (Electronic Control Unit) and a TIRIS transponder. The ECU interrogates the transponder by first initiating a charge phase. The charge phase generates an electromagnetic field around the antenna coil from which the transponder will accumulate and store energy on its internal charge capacitor. This energy is used to power the transponder in the Read Phase where it sends back a total of 128 bits. In the Read Phase, the data read is validated against a known value and depending on match, the vehicle is enabled.

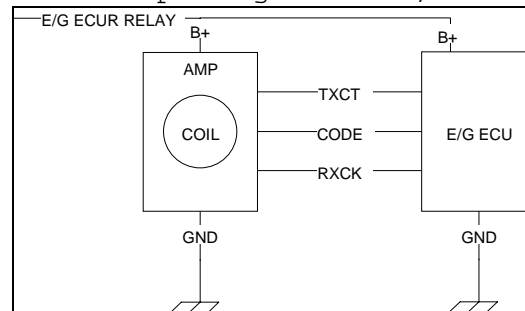

Figure 1 Transceiver to ECU connection

1.1. Charge Phase:

The ECU initiates the charge phase by simply pulling the TXCT signal high to +5V nom.. As long as the TXCT stays at a high level, the transceiver will continuously charge the transponder. When the charge time expires (typically about 50 ms), the ECU will then pull the TXCT line low and continue into the read phase. In the charge phase, the ECU is immune to any activity on both RXCK and CODE line.

1.2. Read Phase:

The read phase consists of three sub-phases, the waiting time, the watching time and the data processing time.

1.2.1. Waiting:

Upon pulling the TXCT line low, the ECU must enter a wait state of not less than 1ms and no more than 1.5 ms after the falling edge of TXCT. In this period of time, no valid data on CODE is present and the ECU must not respond to any transition on CODE or RXCK lines.

1.2.2. Receiving:

After the Waiting state, the transponder sends a FSK signal back to the transceiver. The two nominal frequencies are 123,2 kHz representing a logical "1" and 134,2 kHz representing a logical "0". One bit consists of 16 periods of the corresponding frequency. This signal is picked-up by the coil then amplified and decoded. This decoded information is sent to the ECU, using a Synchronous Serial Interface.

The ECU starts to check the (data) CODE signal to detect the first low to high transition of the Start Byte (7E). The (clock) RXCK signal is synchronous to the CODE after the first rising edge of CODE. After this event the data on CODE is valid during a low level of RXCK. Since the first transition of the CODE signal is the second bit of the start byte, the first bit (LSB) has to be stuffed with a "0". See Figure 3

The Receiving state must be limited depending on the selected Waiting state. The sum of Waiting time and Receiving time should be equal or less than 20 ms. This is the time in which data on CODE can be expected.

1.2.3.Data Processing :

The data sent by the transponder contains 16 Bytes, see Figure 5. The evaluation takes place in the ECU. After all bytes are read and the BCC matches the calculated CRC (specified in the CCIT algorithm) and after validation of the identification data, the ECU enables the starting sequence.

2. I/O Timing

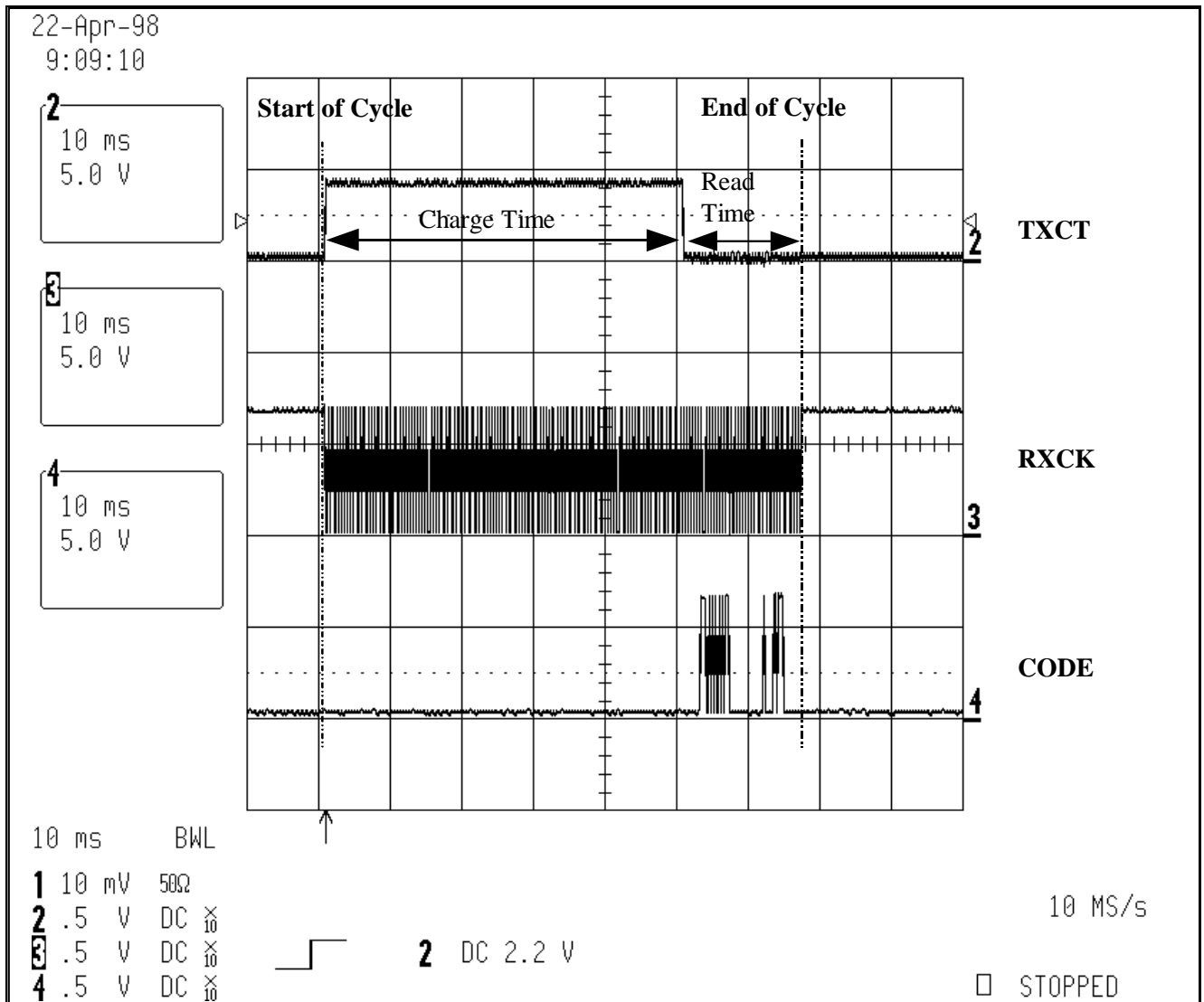

Figure 2 Normal Transmit/Receive Cycle

Note: the state of RXCK and CODE is not defined before and after the complete cycle.

22-Apr-98
9:20:06

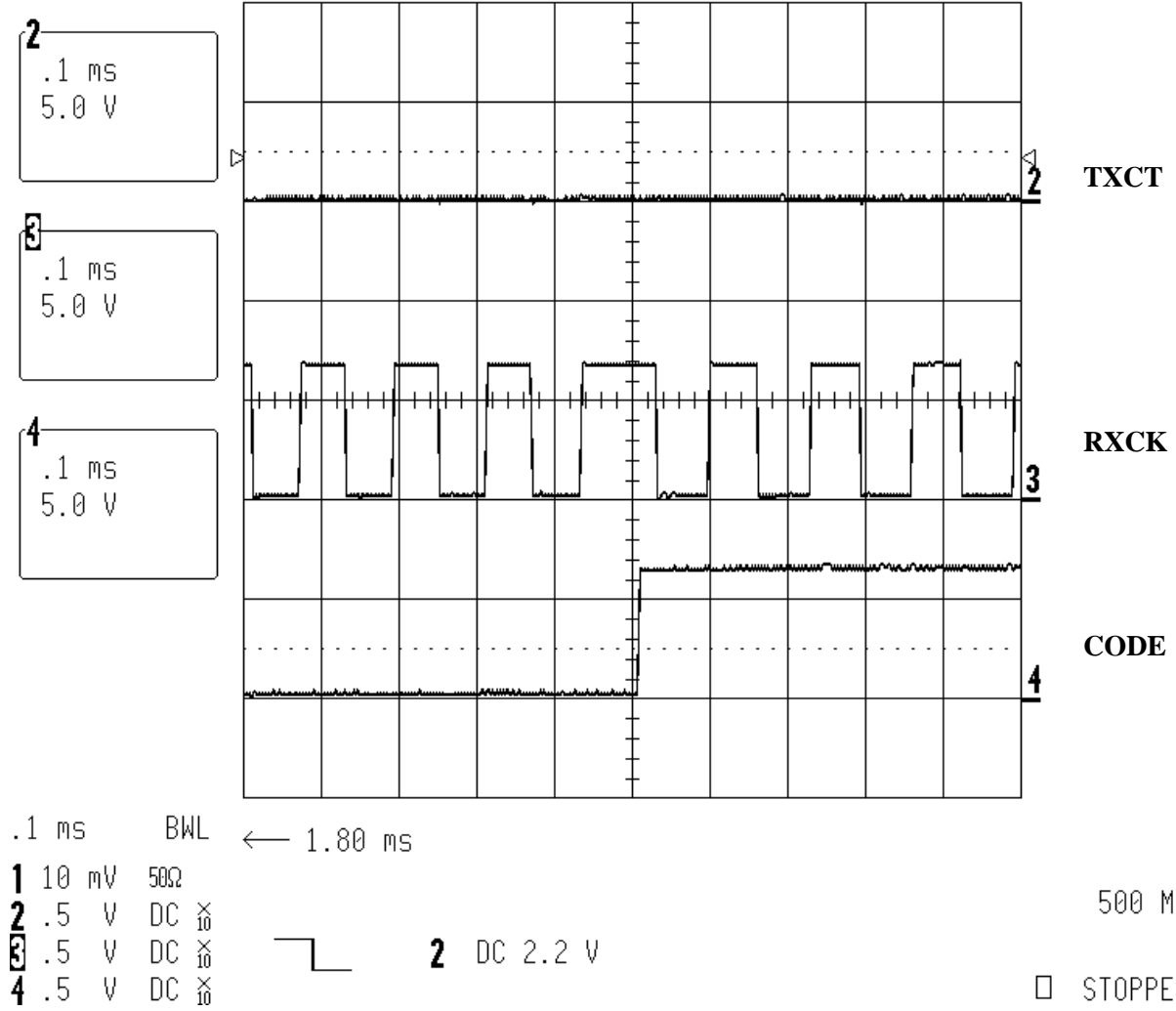

Figure 3 Synchronization of RXCK to CODE

22-Apr-98
11:51:28

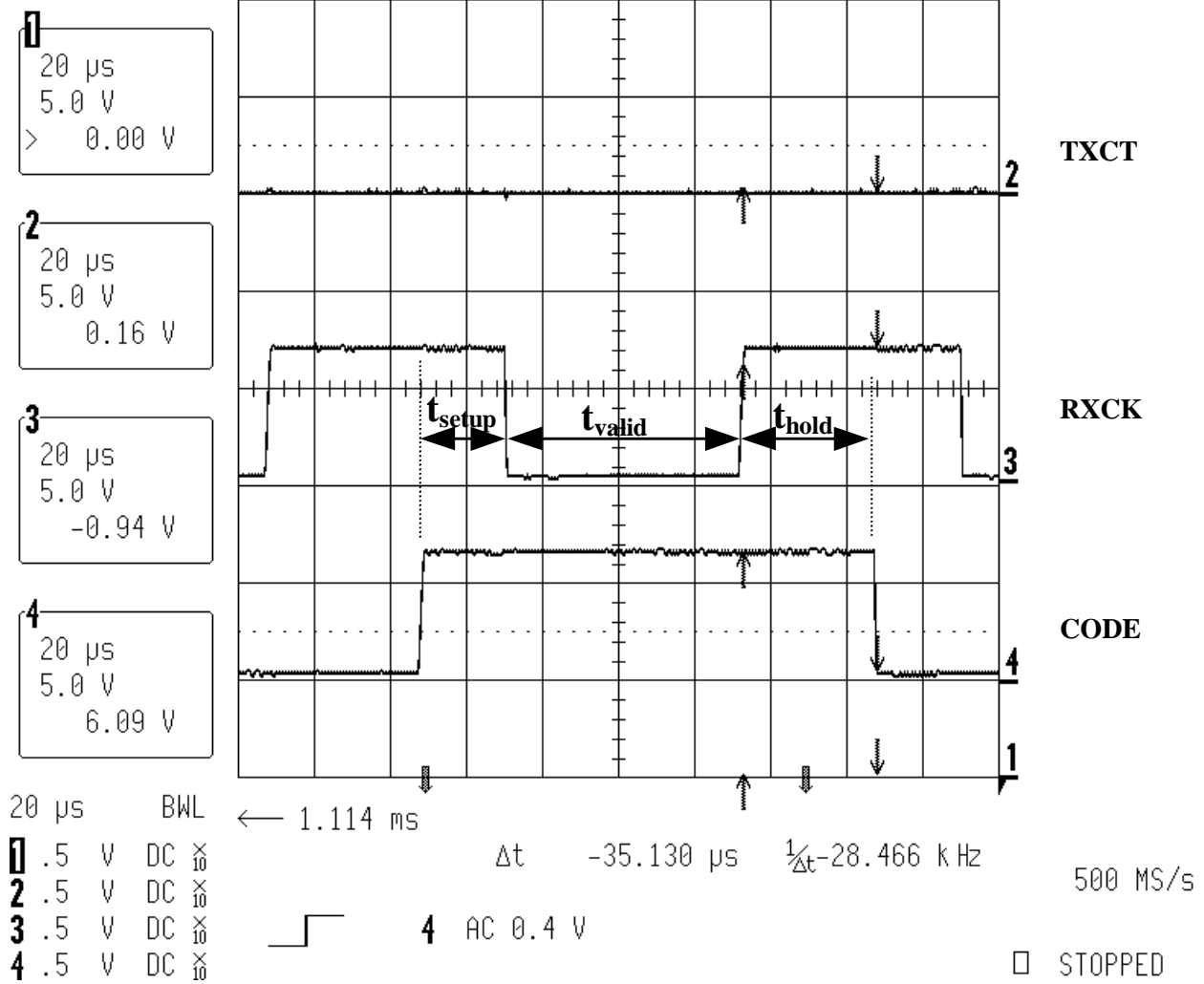

Figure 4 CODE setup and hold times during normal transmission

3. Serial Synchronous Communication Interface Protocol

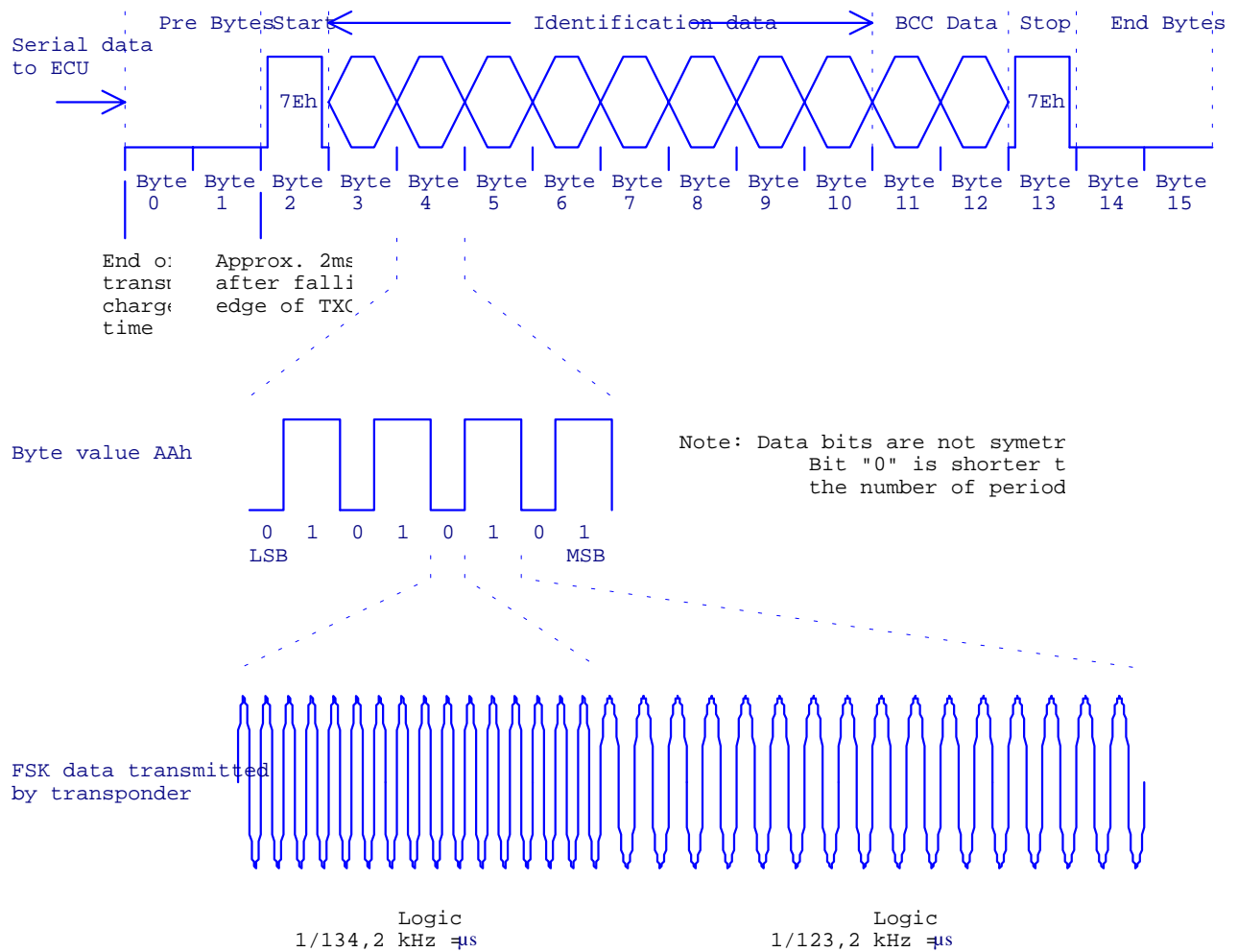

Figure 5 64-bit Read/Only Transponder Read Data Format